

# RIGID

**FIXED AND FLIP TABLES**

**USER GUIDE**

# TABLE OF CONTENTS

<b>Parts Diagram</b>	4-5
24"/30" T-Leg	4
24"/30" C-Leg	4
30" X-Base	5
30" Flip Top Base	5
<b>Safety Information</b>	6
<b>Assembly Instructions</b>	7-13
T-Leg, C-Leg, X-Base	8-9
Flip Top	10-15
<b>Standards &amp; Certifications</b>	15
<b>Warranty</b>	15

# PARTS DIAGRAM

**24"/30" T-LEG**

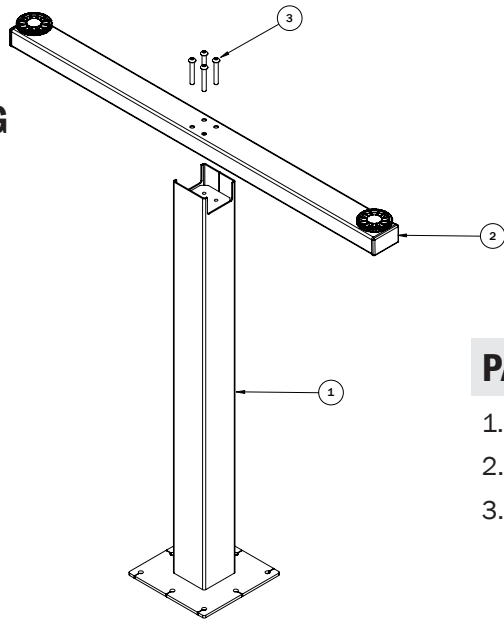

## PARTS

### Qty/Package

1. Column	2
2. Foot Assembly	2
3. M6 x 40mm Button Head Cap Screw	8

**24"/30" C-LEG**

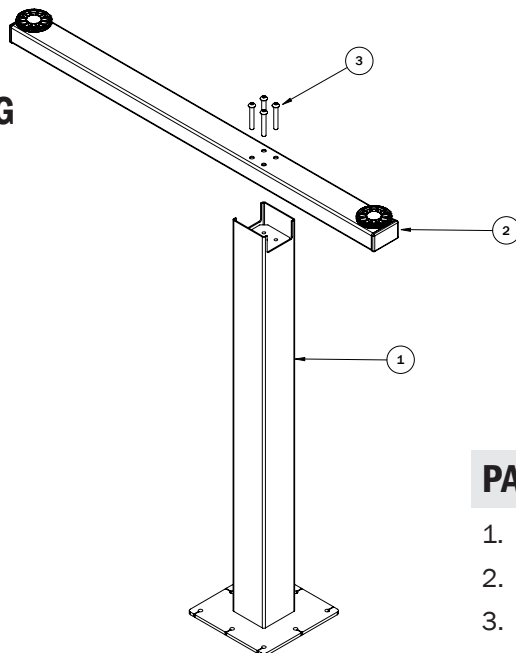

## PARTS

### Qty/Package

1. Column	2
2. Foot Assembly	2
3. M6 x 40mm Button Head Cap Screw	8

## 30" X-BASE

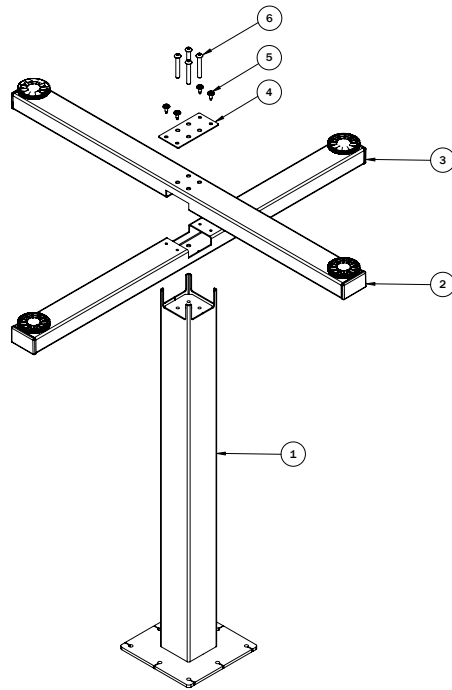

### PARTS

#### Qty/Package

1.	Column	1
2.	Bottom Foot Assembly	1
3.	Top Foot Assembly	1
4.	Mending Plate	1
5.	#8 x 1/2" Self-Drilling Screw	4
6.	M6 x 40mm Button Head Cap Screw	4

## FLIP TOP

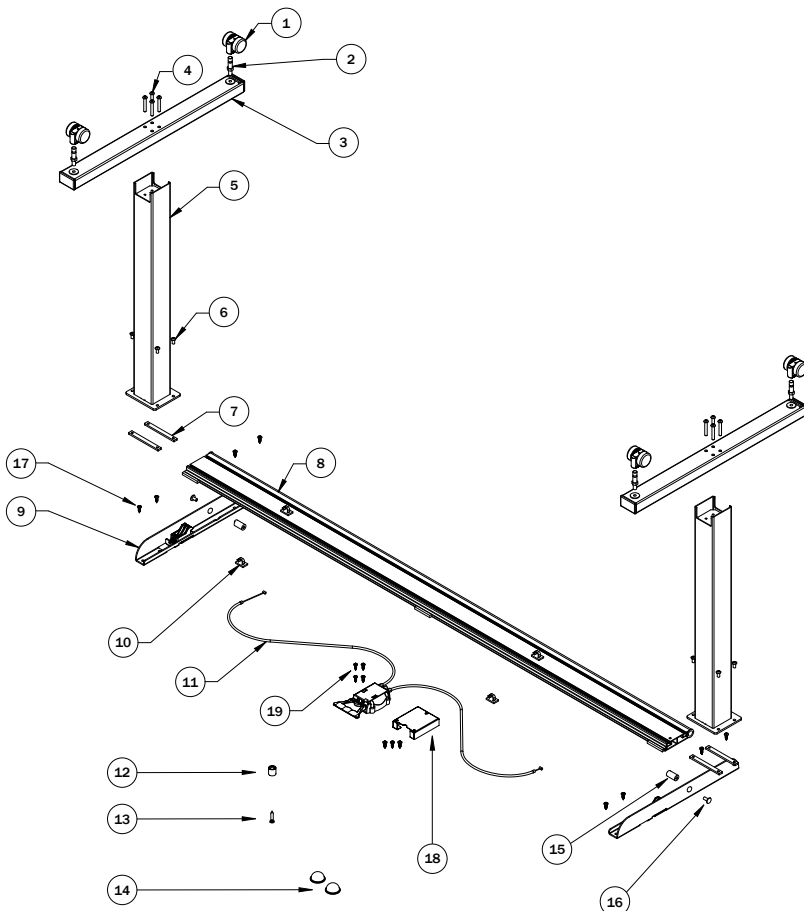

### PARTS

#### Qty/Package

1.	Caster	4
2.	Caster Stem	4
3.	Foot Assembly	2
4.	M6 x 40mm Button Head Cap Screw	8
5.	Column	2
6.	M6 x 12mm Button Head Cap Screw	8
7.	Mounting Plate	4
8.	Support Rail	1
9.	Top Support Assembly	2
10.	Cord Clip	4
11.	Paddle Assembly	1
12.	Plastic Spacer	1
13.	#10x1.00" Phillips Head Wood Screw	1
14.	Collision Bumpers	2
15.	Axle	2
16.	M6 x 12mm Flange Button Head Cap Screw	2
17.	#10 x 3/4" Phillips Head Wood Screw	11
18.	Paddle Cover	1
19.	#8 x 3/4" Phillips Head Wood Screw	4

# SAFETY INFORMATION

## **IMPORTANT SAFETY INSTRUCTIONS** *Save these instructions.*

**WARNING:** To reduce the risk of death, serious injury, or property damage, read and follow this safety information and the provided instructions when assembling this product. Do not change or replace components and accessories.

## **INSTALL ONLY APPROVED WORK SURFACES**

This table system does not include a work surface (desktop). Maximum load for table is 200 lb, including work surface. Desktop dimensions for X-Base are not to exceed 24" (square) or 30" (round). Maximum desktop depth for C- and T-Leg not to exceed 30". If you are unsure if your preferred work surface meets specifications, contact customer service.

## **DO NOT OVERLOAD DESK**

To prevent table from tipping or collapsing, make sure the desk frame is not overloaded by the weight of tabletop and objects on table. Evenly distribute load; excess loads near edges can reduce stability and cause table to tip over.

- Do not exceed maximum load (including weight of desktop) of 200 lb (91Kg)
- Do not exceed edge load of 25 lb when positioning monitors or mounting accessories
- Do not sit or stand on table

## **USE CARE WHEN MOVING TABLE**

- Remove all objects and mounted accessories from the table before moving
- Clear objects and equipment from table before rolling to reduce the risk of tipping over

# ASSEMBLY INSTRUCTIONS

Assembly of the table frame to be made in accordance with this manual.  
Changes to the table frame or improper use may affect the safety, function, and life of your product.

*This manual applies to the following table bases: 24"/30" T-Leg, 24"/30" C-Leg, 30" X-Base, Flip Top*

## ASSEMBLY OVERVIEW

### **FIXED BASES** (page 8-9)

1. Assemble the foot to the column
2. Attach the column to the table top

### **FLIP TOP BASE** (page 10-14)

1. Assemble the foot to the column
2. Attach column assemblies to the support rail
3. Attach top supports to the support rail
4. Install plastic spacer
5. Mount the assembled flip base to table top
6. Install collision bumpers and mount paddle to table top
7. Level table and tighten axle screws
8. Install wire clips and adjust the cable tension
9. Install paddle cover

## FIXED BASE ASSEMBLY

### 1 ASSEMBLE THE FOOT TO THE COLUMN

Install four (4) M6 button head screws through the bottom of the foot and into the threaded holes in the bottom of the column.

X-Base: Be sure to attach mending plate on bottom with accompanying screws.

NOTE: Do not drive the screws into the column with a drill or impact driver without first starting the screws by hand.

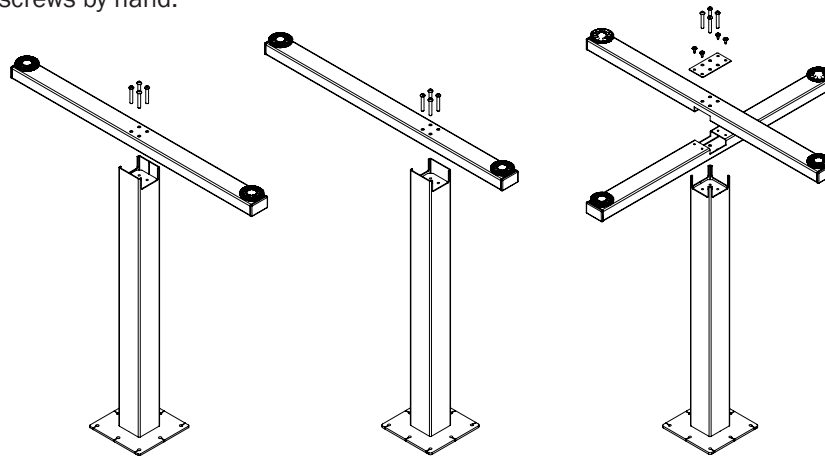

### 2 ATTACH COLUMN TO THE TABLE TOP

Use the chart below to locate the position of the pilot holes on the table top.

X-Base on a square work surface must be mounted with feet in line with the corners of the work surface, as shown. Failure to follow this step will result in poor stability.

LEG CONFIGURATION	FRONT CORNER HOLE DEPTH LOCATION (X)	FRONT CORNER HOLE WIDTH LOCATION (Y)
24 in T-Leg	1.5 in	2.5 in
30 in T-Leg	1.5 in	2.5 in
24 in C-Leg	1.5 in	6.25 in
30 in C-Leg	1.5 in	7.25 in

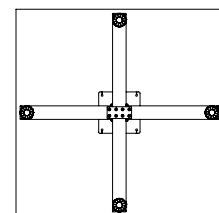
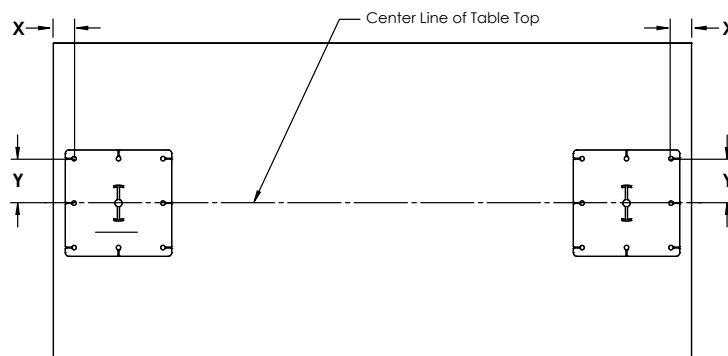

✗ INCORRECT

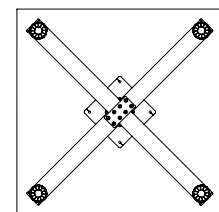

✓ CORRECT

Mark the locations of the pilot holes. Drill the pilot holes to the size recommended by the table top manufacturer. Install the screws through the mounting plate into the table top.

NOTE: The holes in the mounting plate are .280" in diameter.

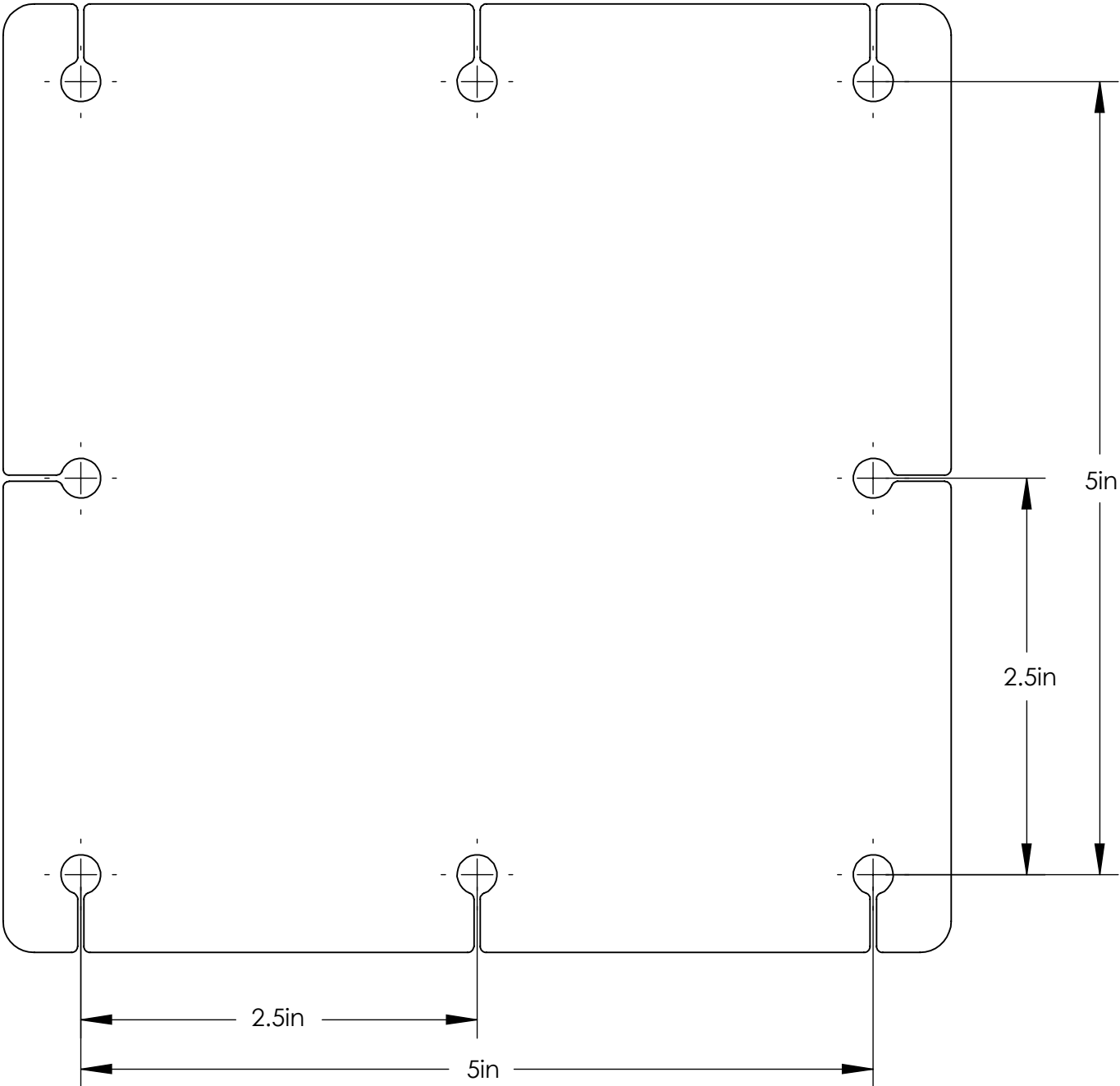

If you have any difficulty assembling this unit, or need to order replacement parts, please contact our Customer Service department. Use the parts diagram on page 4-5 as a reference.



## FLIP-TOP BASE ASSEMBLY

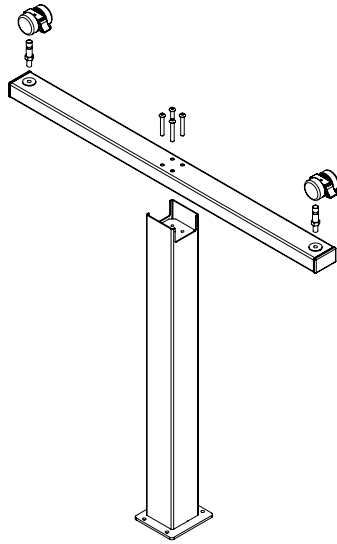

### 1 ASSEMBLE THE FOOT TO THE COLUMN

Install four (4) M6 button head screws through the bottom of the foot and into the threaded holes in the bottom of the column.

NOTE: Do not drive the screws into the column with a drill or impact driver without first starting the screws by hand.

### 2 ATTACH COLUMN ASSEMBLIES TO THE SUPPORT RAIL

Refer to Illustrations A and B.

#### ILLUSTRATION A:

Slide mounting plates into the support rail.

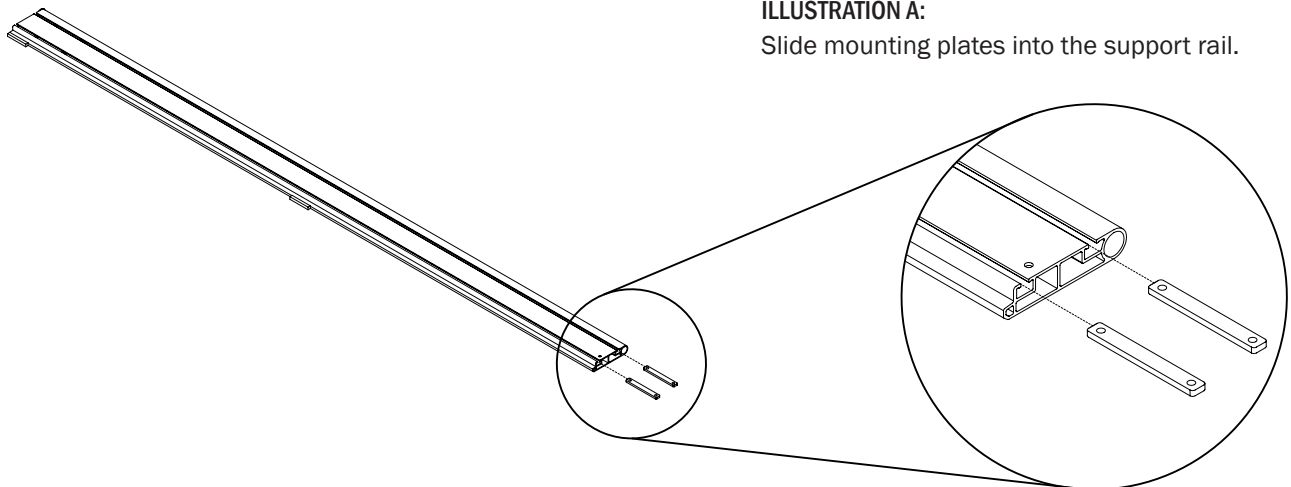

**ILLUSTRATION B:**

Install each column assembly to the support rail using M6x12 button head screws.

**Be sure to mount column assembly 2" from the end of the support rail.**

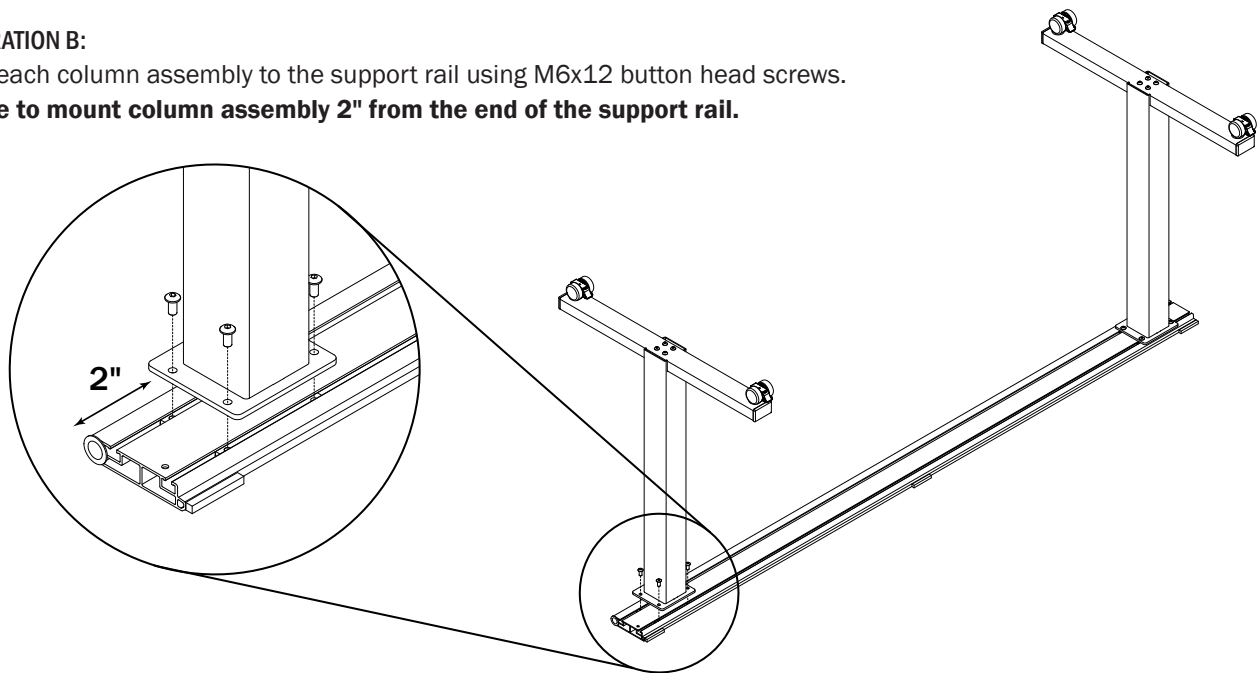

### 3 ATTACH TOP SUPPORTS TO THE SUPPORT RAIL

Refer to Illustrations C and D.

**ILLUSTRATION C:**

Assemble axle to top support by aligning axle protrusion with the corresponding slot on the top support. Fasten with M6x12 flange button head screw. Repeat for both left and right hand top supports. Ensure that the axle is loose and can slide freely in the slot on the top support. **Do not fully tighten screw. Ensure axle flat stays engaged in slot!**

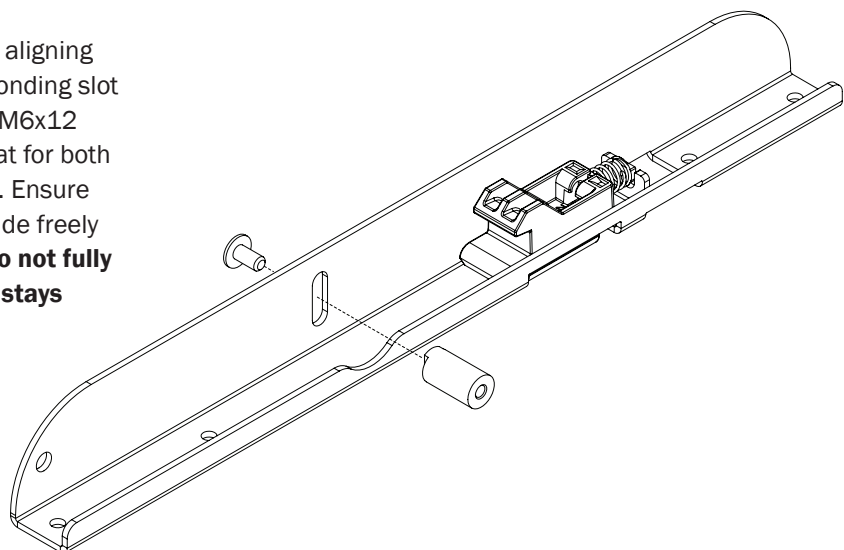

**ILLUSTRATION D:**

Slide the sides of the right hand and left hand top support assemblies onto the support rail.

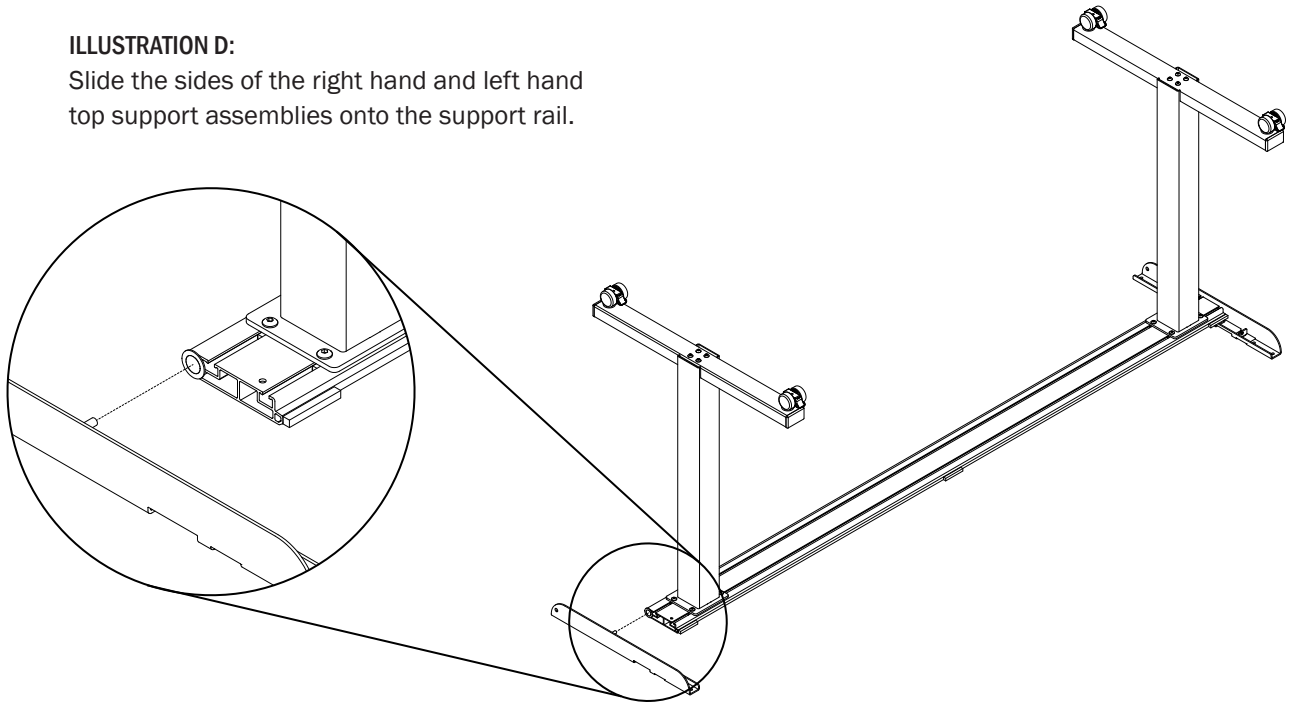

**4 INSTALL PLASTIC SPACER**

Center the plastic spacer in center of work surface. Use the #10x1" screw to attach. **Spacer is required to prevent table top from bowing.**

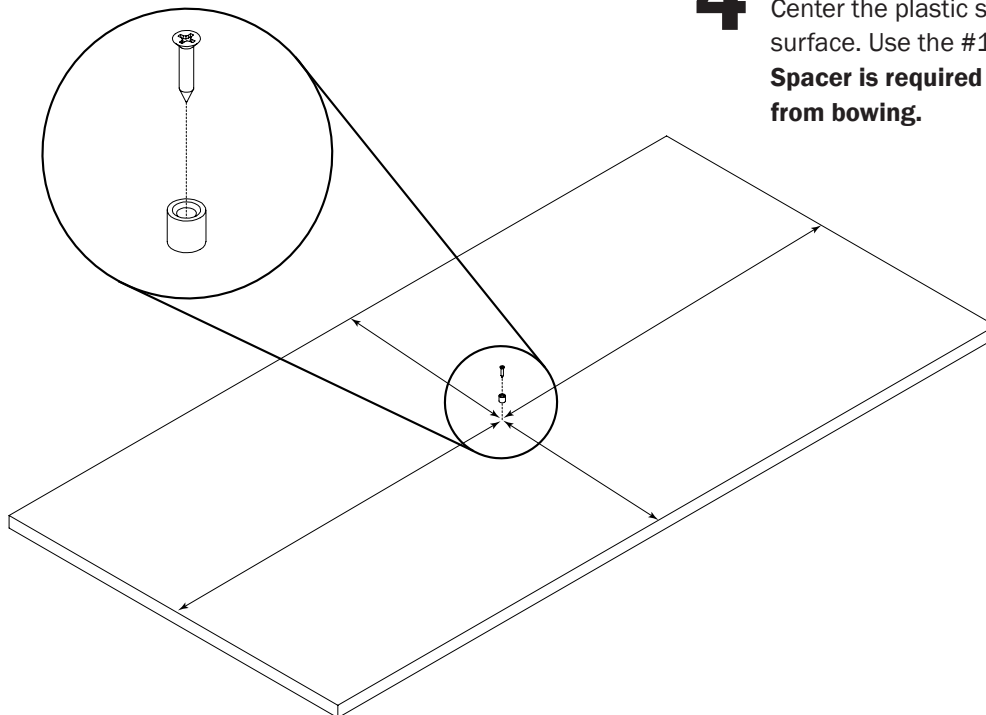

## 5 MOUNT THE ASSEMBLED FLIP BASE TO THE TABLE TOP

Center the flip base on the table top, screw (4) #10x1" screws into each top support.

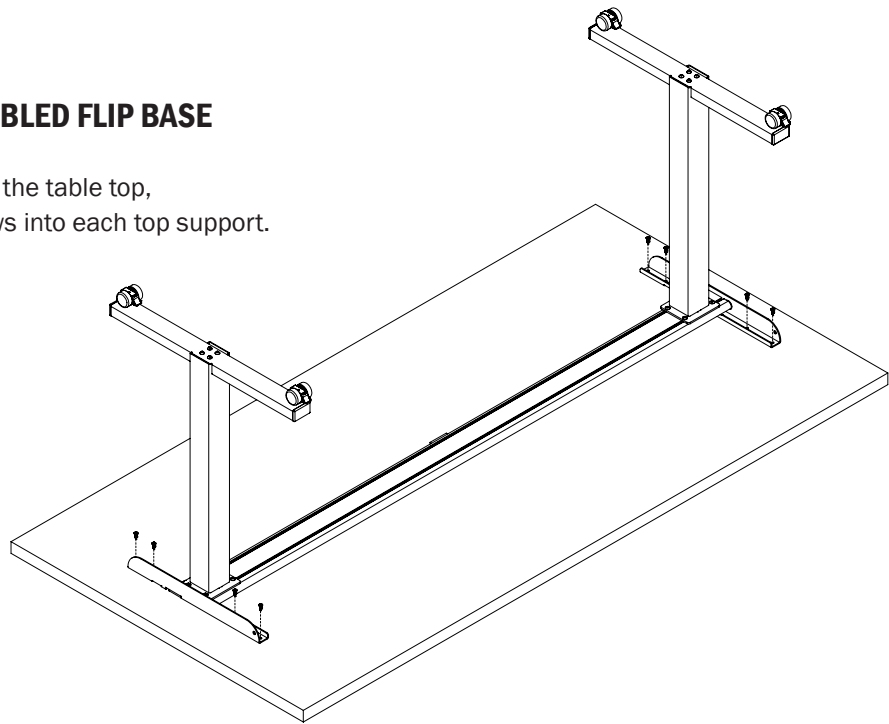

## 6 INSTALL THE COLLISION BUMPERS AND MOUNT THE PADDLE TO THE TABLE TOP

Center the paddle on the length of the table, with the edge of the paddle inset 1" from the front edge of the table top.

**Do not overtighten. Doing so may crack the component.**

Install collision bumpers in line with leg, inset 1" from the back edge of the table top.

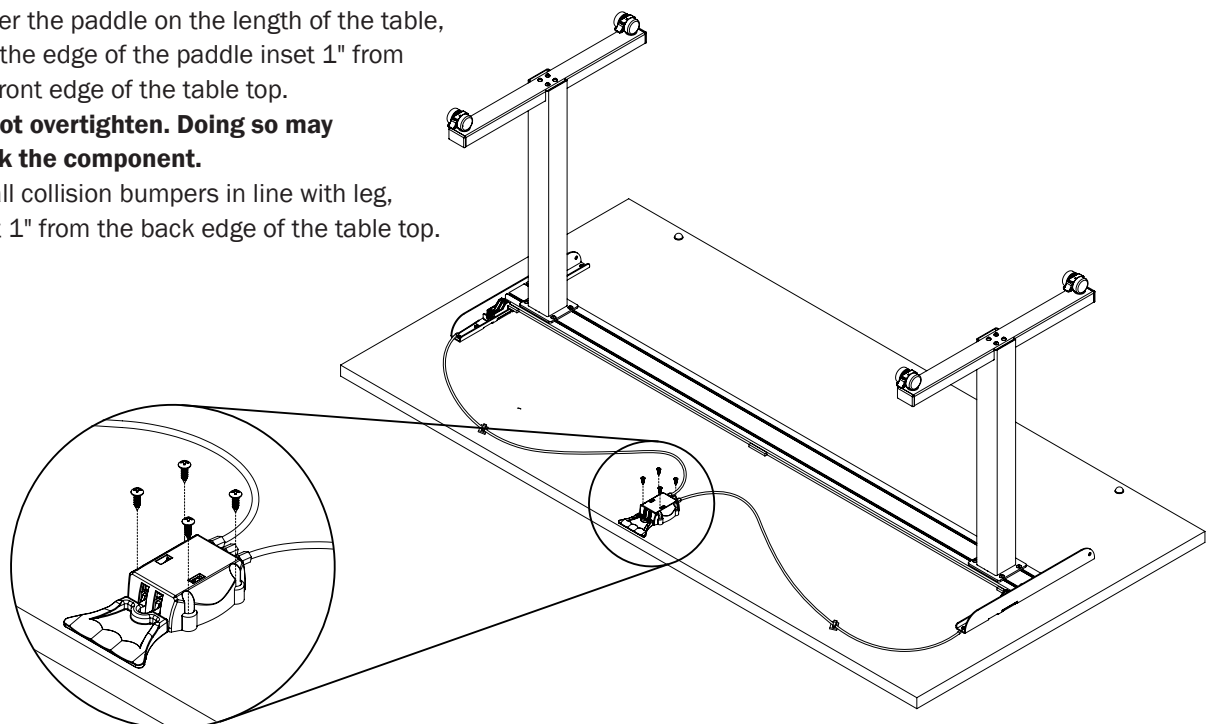

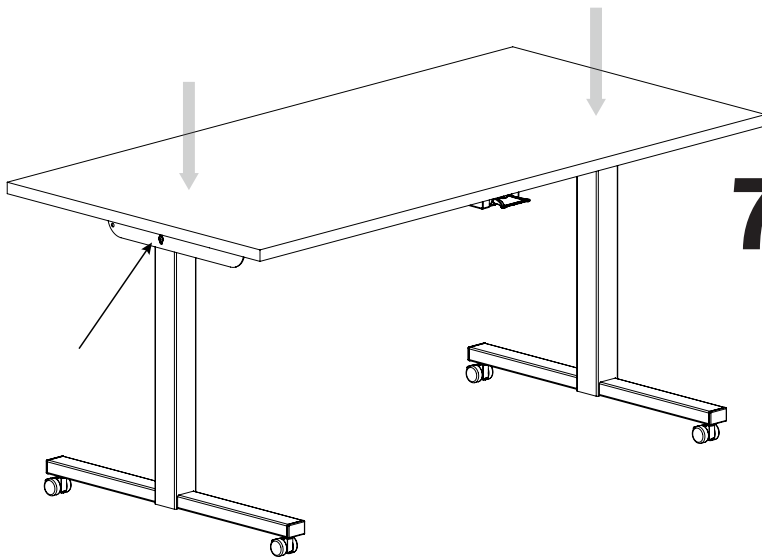

## 7 LEVEL TABLE AND TIGHTEN AXLE SCREWS

Carefully turn the table into the upright position with top in the flat position, then apply light downward pressure on the outside centers of table. This will ensure that the top support is sitting flat on the support rail. Tighten each M6 axle screw on both sides of the table (maximum torque is 10 Nm or 88 in-lbs).

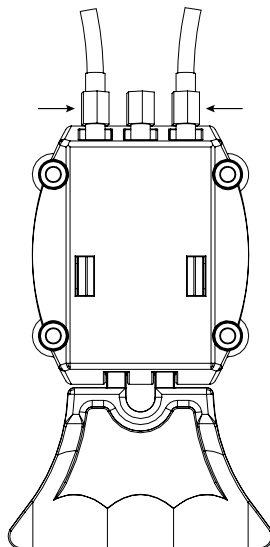

## 8 INSTALL WIRE CLIPS AND ADJUST THE CABLE TENSION

Carefully turn the table upright and depress the release paddle.

Adjust the tension by turning the collar of the cable at the paddle counter-clockwise until the cable is loose, but still connected. Turn clockwise until a slight resistance is felt. Repeat for the opposite side.

Lower table top to flat position and press the release paddle to test. If table does not release, turn collar another quarter turn clockwise. Repeat until table releases.

## 9 INSTALL PADDLE COVER

Center the paddle cover flush with the tabletop over the paddle, without hindering the paddle lever. Only mount paddle cover after the tension has been properly adjusted.

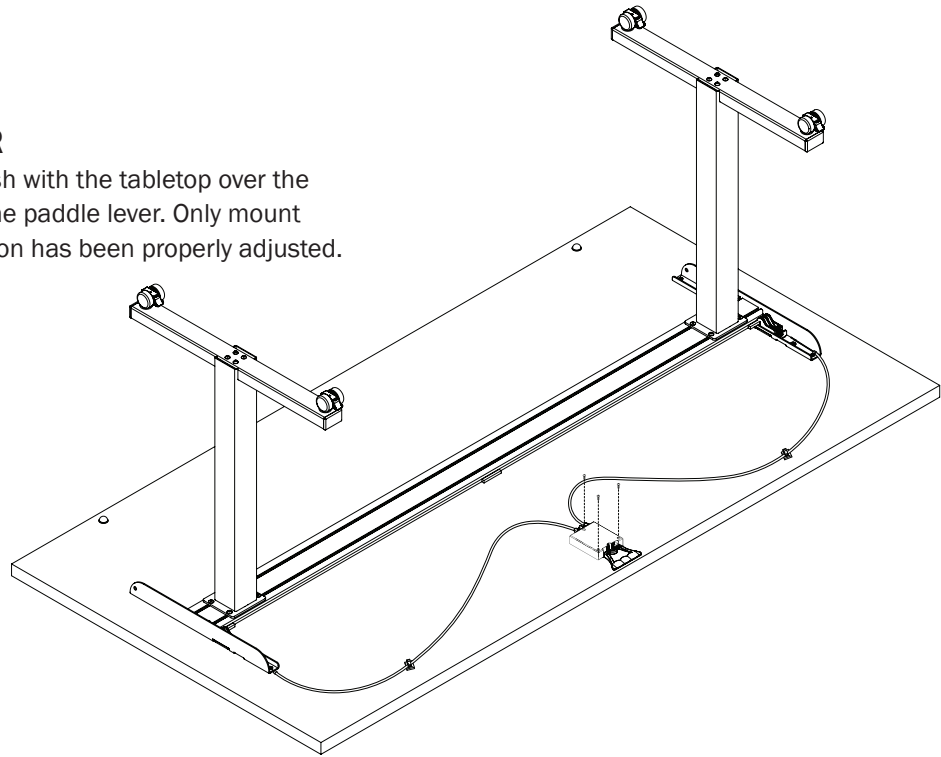

# STANDARDS & CERTIFICATIONS

Meets 2014 BIFMA standards

# WARRANTY

**CONTACT YOUR SALES REPRESENTATIVE  
FOR WARRANTY INFORMATION**



End of life cycle: Once product is disassembled, all steel components can be recycled at your local metal collector. For products with electronic components, see Disassembly Guide.

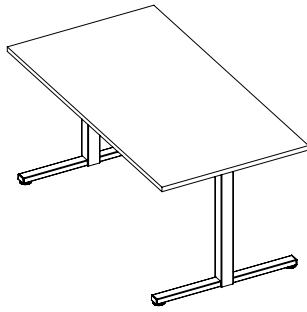

# **RIGID**

## **USER GUIDE**