

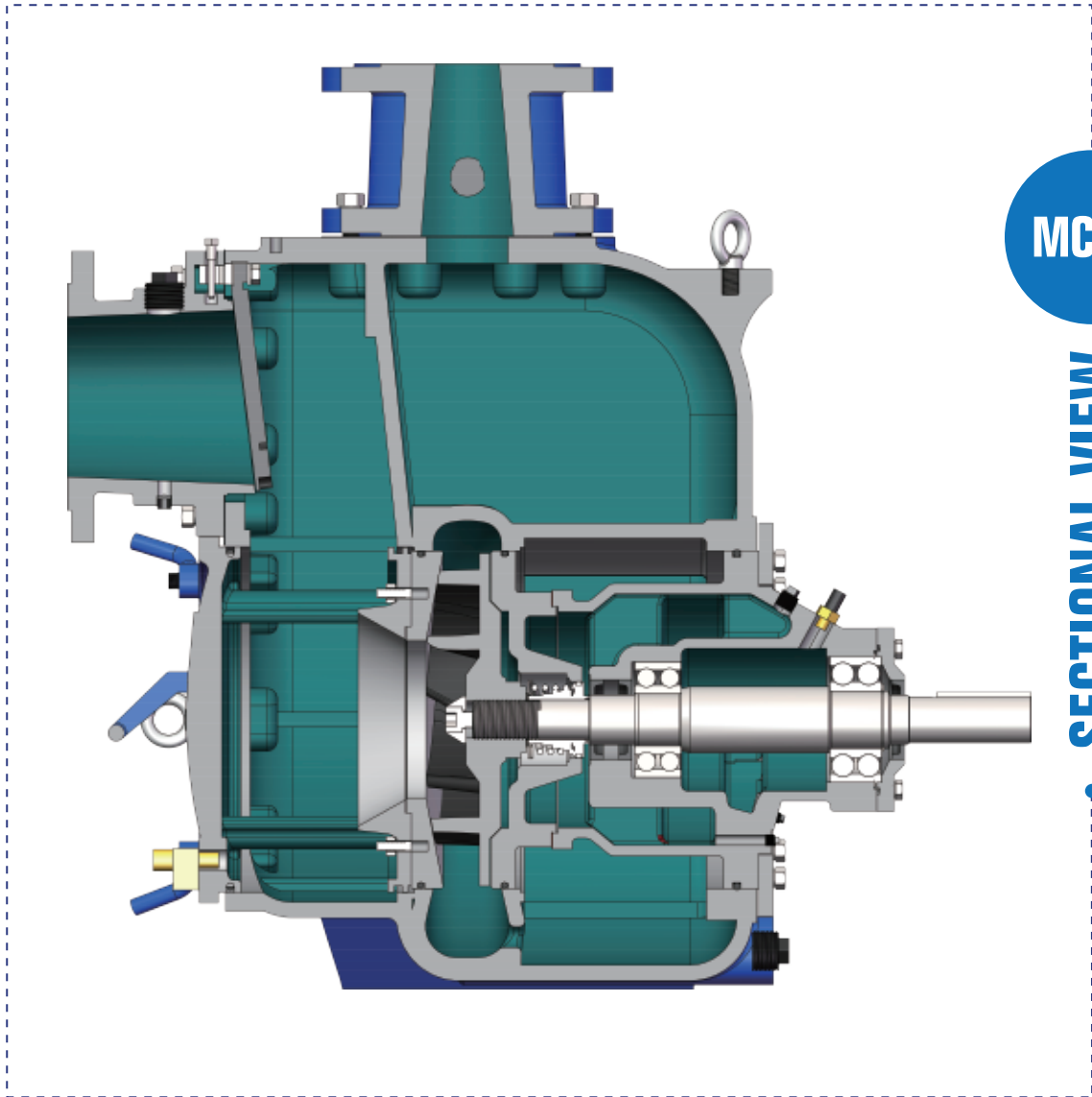

AMOS
A MODEL OF SUCCESS IN FLUID TECHNOLOGY



MCSU SERIES HIGH HEAD SELF PRIMING TRASH PUMP



PRODUCT FEATURES

MCSU series high head pumps are Designed for economical, trouble-free operation with excellent trash handling capacity. Two-vane, semi-open solids handling impeller handles up to 3" diameter solids. The impeller, seal, wears plate and flap valve can all be accessed through the cover plate opening for inspection or service. Atmospheric barrier along with a lip seal provide additional protection of bearings, also allows external monitoring. Cartridge mechanical seal is specifically designed for abrasive and or trash handling service. The entire rotating assembly can be removed without disturbing pump volute or piping .

▼ OUTLINE DIMENSIONS [Unit: inch]

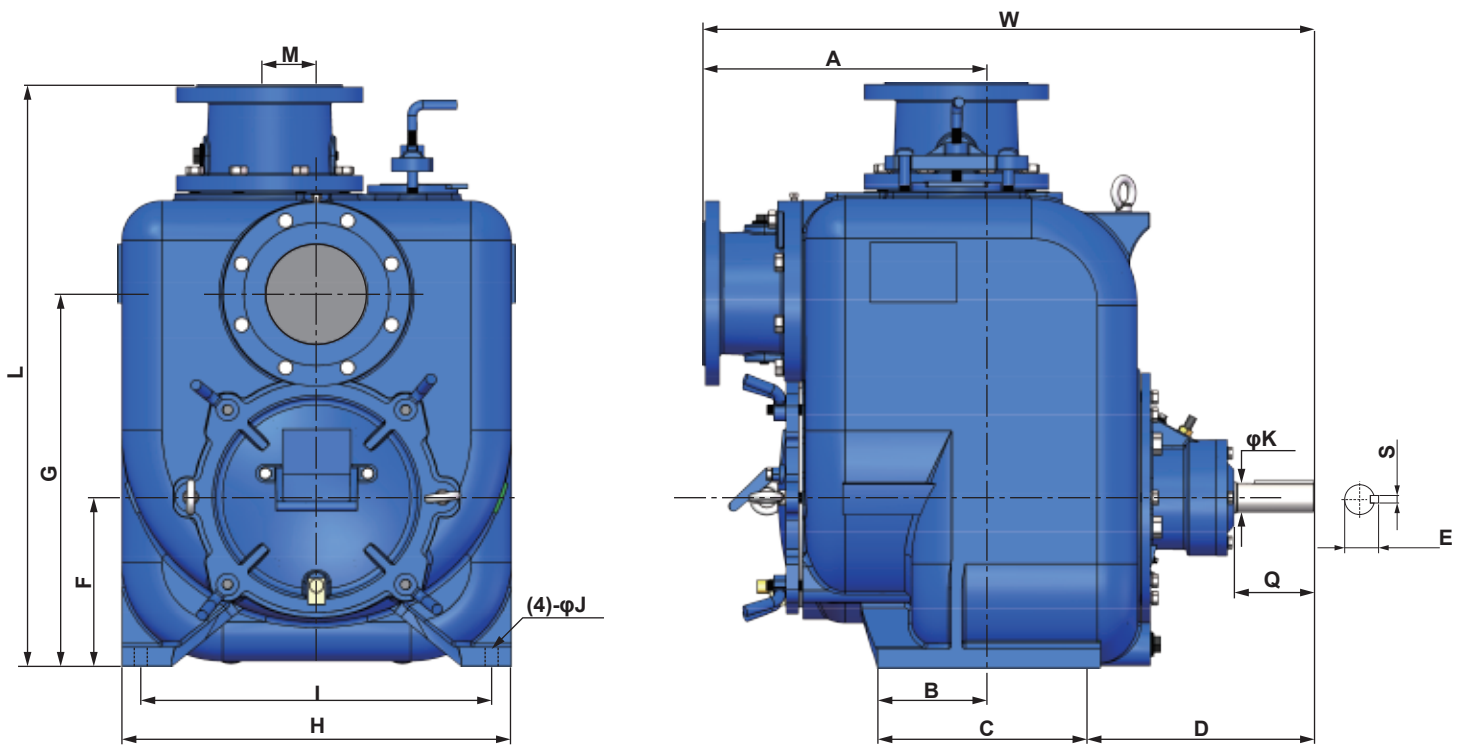

Pump Type	L	G	F	I	H	M	J	W	A	B	C	D	K	Q	S	E	Bare Pump Weight (kg)
MCSU-3	27.20	17.00	7.50	15.50	17.24	2.75	0.71	28.89	11.64	3.00	9.00	11.25	1.50	4.00	0.38	1.68	252
MCSU-4	29.85	20.00	8.75	18.00	20.08	2.75	0.71	31.44	12.54	3.81	11.00	11.71	1.50	5.00	0.38	1.68	305
MCSU-6	34.79	22.37	10.13	20.75	22.83	2.75	0.71	37.21	15.98	3.06	11.00	13.29	1.75	4.63	0.38	1.93	532

PERFORMANCE CHARTS

MCSU SERIES HIGH HEAD SELF PRIMING TRASH PUMP

HEAD
(ft) (m)

