

FULL TIME



Eleventh Edition

Solutions for Cutting, Grinding, Cleaning and Finishing.

WHY WEILER



As an industry leader and global manufacturer of surface conditioning solutions, Weiler Abrasives is eager to create a collaborative partnership to overcome your toughest cleaning, grinding, cutting, de-burring, and finishing challenges.

Weiler Abrasives Group's heritage dates to 1879. Today, the tradition of excellence continues under the fourth generation of family ownership. "While the company has grown and expanded significantly since those humble beginnings, our commitment to developing long-term partnerships with customers, co-workers, and community hasn't changed." Chris Weiler, Executive Chairman, Weiler Abrasives Group.

OUR PURPOSE

To make a difference every day by Leading the Weiler Way, improving the lives of our customers, co-workers, and communities.

OUR VISION & MISSION

To be the global market leader in abrasives by being the best partner our end-users and distributors have, period.



Today Weiler Abrasives Group is a global manufacturer of surface conditioning solutions with customers in over 80 countries.

WEILER VALUE ADDED PROGRAMS

Whether you are looking to improve your surface conditioning processes, optimize your abrasives consumable spend, or train your team on the safe and proper use of abrasives and brushes Weiler Abrasives has a program to help you achieve your goals.

WCP



WEILER CONSUMABLE PRODUCTIVITY

The WCP program helps facilities find cost and time savings in their fabrication operations when they don't have the resources or process to quantify results. WCP is a proven process that effectively and efficiently measures real-world data. This program takes minimal effort to deploy in your facility because abrasives experts implement it.

Through a simple, yet effective approach the WCP program identifies improvements by evaluating your operations and how abrasives are used in your facility.

- ▶ On-site assessment
- ▶ Test abrasives
- ▶ Quantify impact
- ▶ Present documented cost & time savings

SPOT



WEILER SPOT SAFETY TRAINING

The SPOT safety training program is designed to educate operators on how to use abrasives and brushes safely and effectively. The program covers information on proper usage, potential hazards, and safety tips.

By completing the SPOT Safety Training Program, participants will be able to:

- ▶ Understand the basic principles of abrasive and brush safety
- ▶ Identify potential hazards before an incident occurs
- ▶ Implement safe work practices to avoid accidents and injuries

WPS



WEILER PROCESS SOLUTIONS

The Weiler Process Solutions (WPS) program delivers customized solutions based on your specific application needs. The program leverages the latest technology and on-site technical expertise to optimize high-volume production manufacturing processes for customers. WPS makes it easier to achieve your cost savings and productivity improvement goals.

- ▶ Reduce cycle times and eliminate production bottlenecks to improve throughput
- ▶ Reduce total cost per part
- ▶ Minimize rework and reduce waste
- ▶ Improve energy efficiency and sustainability for your business
- ▶ Reduce working capital commitment by optimizing consumable inventory
- ▶ Reduce process variability to improve part quality and consistency

TABLE OF CONTENTS

Weiler Value Added Programs	3
Safety Information	5
New Products.....	7
Industrial Grinding Wheels.....	8

BONDED ABRASIVES

Technical Information	9-31
Cutting Wheels	11-13
Small Diameter Cutting Wheels.....	14-17
Large Diameter Cutting Wheels.....	16
Grinding Wheels	17
Combo Wheels.....	18-19
Pipeline Wheels.....	20
Cups, Cones & Plugs.....	21
Foundry Abrasives.....	22-23
	24-31

COATED ABRASIVES

Technical Information	32-51
Flap Discs.....	36-37
Resin Fiber Discs.....	38-43
Blending Discs	44-47
Trim-Kut® Discs	48-49
Flap Wheels	49
	50-51

NON-WOVEN ABRASIVES

Technical Information	52-56
Strip Discs.....	52
Surface Conditioning Discs.....	53
Unitized Wheels.....	54
Interleaf Flap Wheels	55
Hand Pads	56

POWER BRUSHES

Technical Information	57-105
Knot Wire Wheels	60-66
Weld Cleaning Brushes	67-73
Crimped Wire Wheels.....	72-73
Nylon & Tampico Wheels.....	74-81
Cup Brushes	82
Stem-Mounted End Brushes.....	83-85
Crosshole Deburring Brushes	86-89
Power & Hand Tube Brushes.....	90
Crossflex Honing Brushes.....	91-95
Miniature Brushes	96-98
Non-Sparking Brushes	100-101
Wide Face Brushes	102-103
	104-105

NYLOX® BRUSHES

Technical Information	106-133
Engineered Products & Solutions.....	110-116
Troubleshooting Guide.....	117
Small Feature Deburring Products.....	118
Flat Surface Deburring Products.....	119-123
Targeted Feature Deburring Products	124-127
Application Engineered Wheels	128-130
FME Area Product Solutions.....	131
Adapters & Drive Arbors	132
	133

MAINTENANCE

Technical Information	134-157
Brooms, Sweeps & Handles.....	135-136, 153
Upright & Whisk Brooms.....	137-140
Dusters, Dust Pans & Squeegees.....	141
Vehicle Care Products.....	142
Scrub & Utility Brushes	143
Mops & Dusting Brushes.....	144-145
Masonry & Applicator Brushes	146
Scratch Brushes	147
Flue Brushes.....	148-150
Tube Fitting Brushes	151
Paint & Parts Cleaning Brushes.....	152
Chip & Oil Brushes & Industrial Paint Brushes	154
Marking, Glue & Acid Brushes	155
Paint Rollers & Accessories	156
	157

LEARN MORE:
WEILERABRASIVES.COM

HOW CAN WE HELP YOU? CONTACT US TODAY!

To place an order or locate a distributor in your area, contact our Customer Experience Team at 800-835-9999 or orders@weilerabrasives.com.

For more information and to schedule a consultation with a Weiler Process Solutions expert visit: weilerabrasives.com/wps.
To discuss specific requirements with a specialist call: 800-835.9999.



SAFETY INFORMATION

All of Weiler's products are made to the strictest quality standards and specifications and are designed to provide superior work performance and safe operation when used properly.



WARNING: Failure to observe safety precautions may result in injury.

Many manufacturers mark some safety warnings, recommendations and usage restrictions directly on the product. However, it is not always practical to include even the most limited safety information on the product itself. Therefore, the operator **MUST READ** and **FOLLOW** all instructions supplied in or on the product container as well as those marked on the product.

SAFETY STANDARDS - ESTABLISHED BY THE AMERICAN NATIONAL STANDARDS INSTITUTE

Weiler power brushes and abrasives conform to the ANSI standards listed below. All operators of power brushes and abrasives must comply with these safety standards.

- ANSI B165.1 "Power Tools - Power Driven Brushing Tools - Safety Requirements for Design, Care and Use"
- ANSI B7.1 "Safety Requirements - For the Use, Care and Protection of Abrasive Wheels"

AVAILABILITY OF ANSI STANDARDS

Based on the collective experience of the American Brush Manufacturers Association Industrial Division members (ANSI B165.1) and the United Abrasives Manufacturers Association's Bonded Division (ANSI B7.1), both ANSI Standards are referenced and provided solely as a public service for the guidance of the users of the members' products. All Brush and Abrasive recommendations are not necessarily complete with respect to any particular application and common sense safety considerations should generally be followed. Any applicable federal, state, local law or regulation must be strictly adhered to and is controlling over any recommendation contained herein.

TOOL/WORK REST

On bench grinders, tool/work rests should be used to support the work-piece during use. It should have a maximum opening of 1/8" to the product face. Only adjust the rest when the product is not in motion.



Hearing Protection



Respiratory Protection



Safety Glasses / Face Shield



Protective Clothing



Leather Gloves



Tool Guard



METAL FABRICATION

Segments with critical to quality weld applications like Pipeline, Construction, Pressure Vessel, and Structural Metal Fabrication.



SHIPBUILDING

New construction and repair of commercial and military ships.



FOUNDRY

Delivering productivity and safety-enhancing solutions for foundry cleaning rooms specializing in cast iron, gray and ductile iron, cast steel, stainless, aluminum, non-ferrous, and titanium.

DELIVERING VALUE TO GLOBAL MARKETS

Weiler Abrasives works in various industrial settings across the globe to solve tough challenges, enabling businesses like yours to get more done, more efficiently.

Aerospace

Automotive

Building & Construction

Facility Maintenance

Food & Pharma

Foundry

Gear

Heavy Equipment

Manufacturing

Metal Fabrication

Pipeline Construction

Power Generation

Primary Metals

Production Welding

Pressure Vessel

Shipbuilding

Transportation



GEAR GRINDING

High precision gear manufacturers serving Automotive, Aerospace, Power Generation, Shipbuilding, Heavy Equipment, and other industrial segments.



PRIMARY METALS

Producers of titanium, specialty alloys, stainless steel, and rail car wheel producers.

WHAT'S NEW?



TIGER 3D MAX ABRASIVES

Tiger® 3D MAX ceramic abrasives are engineered for maximum cut rate, durability, and control on the toughest metals. Powered by advanced 3D precision-shaped grain, they deliver faster material removal, cooler grinding, and longer disc life to increase throughput and reduce changeovers.



Tiger 3D MAX Flap Discs

Page 38



Tiger 3D MAX Resin Fiber Discs

Page 45



Tiger 3D MAX Blending Discs

Pages 48



Page 53

TIGER NON-WOVEN STRIP DISCS

These discs deliver unmatched cleaning power and product life for steel and stainless steel.



Pages 10-20

TIGER 2.0

An evolution in abrasives technology – designed to be more than just a better product. It was created to help you do your best work.



Page 19

TIGER MILL SCALE GRINDING WHEELS

These wheels are designed to quickly and efficiently remove mill scale from hot-rolled carbon steel. A circular studded design aggressively cuts through the hard surface and prevents loading or glazing.



GEAR GRINDING



Cutting Lead Times and Offering Piece of Mind.



Precision Express delivers custom gear grinding wheels in days, not months, thanks to in-house profiling and on-hand stock.

INDUSTRIAL GRINDING WHEELS

DRIVING PRODUCTIVITY

People who take work seriously partner with Weiler Abrasives. We work collaboratively to help solve our customers' biggest challenges.

We understand that every production operation is different, so is every production challenge. One solution does not fit all. Weiler experts can examine your specific production and product challenges and develop customized solutions that optimize your operation.

Together we will maximize productivity enabling your business to be more efficient and ultimately more profitable.

WORLD-CLASS CAPABILITIES

- Best-in-class lead-times
- CNC finishing
- On-site technical support
- Precision tolerances
- Extensive R&D capabilities
- Green manufacturing footprint
- Unrivaled safety inspection
- Global distribution network
- Custom wheel shapes
- Newest abrasive and bond technologies



PRECISION VITRIFIED

Weiler's precision vitrified products use high performance bonding components paired with advanced abrasives to provide the most competitive products in the market. These products are designed to maximize cut rate, reduce cycles times, increase depth of cut, reduce dressing cost and improve surface finish.

Products: Standard and custom profiles that are all CNC finished to tight tolerances with the ability to produce up to 50" diameter wheels



HOT PRESSED CONDITIONING

Weiler specializes in designing high performance conditioning wheels for stainless steel, specialty alloy, carbon steel and titanium applications. These wheels remove hard oxide scale formed in the process of casting slabs, ingots and bars in primary metals facilities.

Products: 24", 25", and 36" diameter hot press metal conditioning wheels



HIGH PERFORMANCE ROLL GRINDING

Weiler produces high performance roll grinding technology for both cold mill and hot mill applications. These wheels are designed to work on rolls ranging from iron roll to specialty tool steel rolls. Our unique technology will maximize your process efficiency and provide substantial cost savings.

Products: Resin and vitrified bonded wheels 30"-42" in diameter



GEAR GRINDING

Utilize Weiler's full line of Gear Grinding Solutions to maximize machine efficiency with high performance products that fit all gear grinding applications.

Products: Single profile, bevel, worm (continuous), and hob sharpening products that are designed to pair with any gear grinding machine.



PERFORMANCE YOU EXPECT

Weiler's line of bonded abrasives deliver consistency and performance to Metal Fabrication professionals. This high quality line includes cutting, grinding and combination wheels that are available in performance tiers, offering a choice between long life, fast cut, or both.

Technical Information	12-13
Cutting Wheels	14-17
Small Diameter Cutting Wheels	16
Large Diameter Cutting Wheels	17
Grinding Wheels	18-19
Combo Wheels	20
Pipeline Wheels	21
Cups, Cones & Plugs	22-23
Foundry Abrasives	24-31

BONDED ABRASIVES

CUT THROUGH BARRIERS BETWEEN YOU AND YOUR BEST WORK

Introducing Tiger 2.0 — An evolution in abrasives technology. It was designed to be more than just a better product. It was created to help you do your best work.

CUT THROUGH INEFFICIENCY

Tiger 2.0's unique formulation provides the same fast cutting speed, while lasting up to 40% longer. And it's industry first, patent pending optimal use line ensures you get more done with less.

CUT THROUGH SAFETY ISSUES

Tiger 2.0 delivers predictable, smooth cutting and grinding, making the work safer. And it now has a QR code so operators can access crucial safety information right where — and when — they need it.

CUT THROUGH LABOR SHORTAGES

Tiger 2.0 makes cutting and grinding easier, which means operators aren't as worn out at the end of each shift. The unique formulation also produces more consistent work from user to user, reducing training time and even re-work.

3X

*Tiger 2.0 cuts through the barriers holding you back from realizing gains while reducing costs. In some cases, users are seeing **3 times more efficiency** over their previous abrasives.*

NEW 2.0

Weiler Tiger 2.0 cutting, grinding, and combo wheels are the next evolution in abrasives.

PATENT PENDING OPTIMUM USE LINE

Using the wheel to its full life reduces change-overs, which helps users be more productive while reducing waste and abrasive spend.



NOW AVAILABLE

in AO, Zirc, Inox and Ceramic

QR code provides quick access to important safety information.

IMPROVE SAFETY



ANTI-CHIPPING TECHNOLOGY

Advanced 2.0 bond formulation reduces uneven edge wear and chipping, improving user experience and extending wheel life.

FAST SPEED + LONGER LIFE

Up to **40% longer wheel life** reduces change-overs and delivers more cuts.



Tiger 2.0



Industry Standard

INDUSTRY STANDARD

WEILER WHEEL



SELECTING THE RIGHT WHEEL

Weiler's bonded abrasive wheels help Metal Fabrication professionals get the most demanding jobs done right, and done fast. Our high quality line helps you select the best solution for your toughest jobs. Whether you're looking for serious stock removal, beveling, grinding, notching, cutting or edge softening, Weiler will get it done for you.



P **MAX PERFORMANCE**
SUPERIOR LIFE & CUT



CUT RATE: ●●●●●
LIFE: ●●●●●

TIGER[®] CERAMIC
Self-sharpening and cool – grinds at lower temperatures with less friction and less effort, reducing heat discoloration of the work piece.

GRAIN TYPE
Ceramic alumina

CONTAMINANT FREE
CONTAIN LESS THAN 0.1% IRON, SULFUR & CHLORINE

BEST ON

STEEL / METAL
STAINLESS **HARD-TO-GRIND**

Hard-to-Grind metals include tool steel, inconel, high nickel alloy, titanium and armored steel

TIGER[®] PIPELINE
Designed for bead and angle grinding applications on the pipeline.

GRAIN TYPE
Zirconia alumina + ceramic alumina infusion

BEST ON
STEEL / METAL

P **HIGH PERFORMANCE**
FAST CUT & LONG LIFE



CUT RATE: ●●●●○
LIFE: ●●●●●

TIGER ZIRC
Self-sharpening grains retain a high cut rate throughout the life of the wheel for exceptional performance.

GRAIN TYPE
Cutting/Combo: Zirconia alumina
Grinding: Zirconia alumina + ceramic alumina infusion

BEST ON
STEEL / METAL

includes structural steel and cast iron

TIGER INOX
Tiger INOX wheels deliver a worry-free solution for stainless steel applications.

GRAIN TYPE
White aluminum oxide

INOX **CONTAMINANT FREE**
CONTAIN LESS THAN 0.1% IRON, SULFUR & CHLORINE

BEST ON
STAINLESS

and harder grade steel

TIGER ALUMINUM
Weiler's non-loading formula delivers a fast and consistent cut rate on aluminum and soft alloys.

GRAIN TYPE
Silicon carbide / aluminum oxide blend

CONTAMINANT FREE
CONTAIN LESS THAN 0.1% IRON, SULFUR & CHLORINE

BEST ON
ALUMINUM

P **PERFORMANCE**
LONG LIFE



CUT RATE: ●●●●○
LIFE: ●●●●●

TIGER AO
Tiger wheels provide an even, sharp, clean cut and a hard bond extends wheel life.

GRAIN TYPE
Aluminum oxide

BEST ON
STEEL / METAL

V **VALUE**
FAST CUT



CUT RATE: ●●●●○
LIFE: ●●●●○

WOLVERINE[®]
Fast cut rate and consistent performance at a good value.

GRAIN TYPE
Aluminum oxide

BEST ON
STEEL / METAL

Key:
P PERFORMANCE LINE Industrial Grade **V** VALUE LINE Professional Grade

Read and Comply with ANSI B7.1

MARKS ON THE LABEL



TYPE

Cutting	Type 1 (Flat)	Type 27 (Depressed Center)
---------	---------------	----------------------------

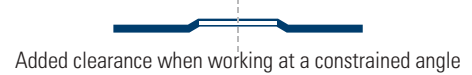

Grinding	Type 27 (Depressed Center)	Type 28 (Depressed Center)	Type 29 (Depressed Center)
----------	----------------------------	----------------------------	----------------------------

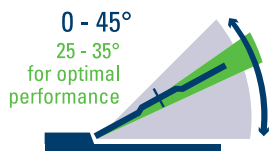

Flat profile with depressed center allows for a wide range of grinding angles (0-45)

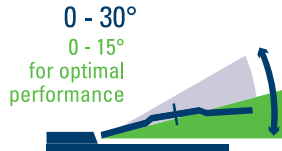

Designed for increased aggression at lower working angles and increased access

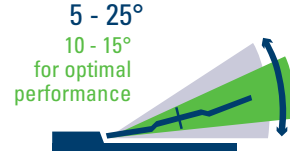

Increases surface contact, deters gouging, and improves operator comfort

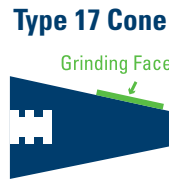
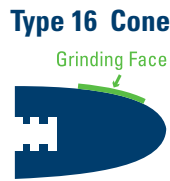
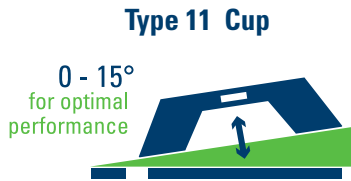

GRAIN / GRIT / GRADE

Selecting the best grain, grit and grade combination for your application can increase wheel effectiveness and user productivity. Use the charts below to help pick the right wheel for the job.

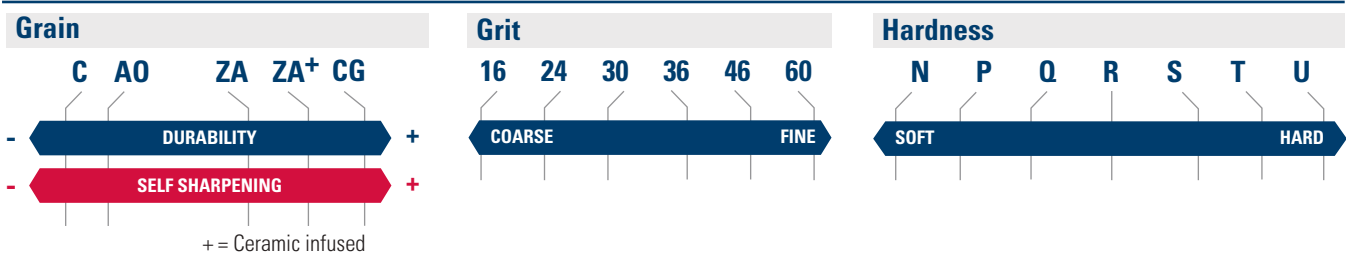

APPLICATION

When selecting a wheel, always choose the thinnest wheel that will perform the cut while maintaining desired product life.

ULTRA THIN WHEEL 1MM	THIN WHEEL .045"	THIN WHEEL .060"	CUTTING WHEEL 3/32"	PIPELINE NOTCHING WHEEL 1/8"	COMBO WHEEL 1/8"	PIPELINE NOTCHING WHEEL 1/8"	GRINDING WHEEL 1/4"	CONES & PLUGS	CUP WHEELS
Sheet metal, tubes, profiles and small cross-section rods	Tubes, bar stock and large cross-sections	Angle Iron, large cross-sections	Notching	Switching between cutting and grinding	For tough root pass notching & facing applications on the pipeline	Heavy stock, scale and weld removal, weld blending, edge beveling and torch-cut softening	I.D. cleaning, hole edge beveling, smoothing weld seams, removing gates & parting lines	Heavy metal removal, grinding, transitioning, rough beveling & removing crack & flaws	

WHY WEILER
BONDED ABRASIVES
COATED ABRASIVES
NON-WOVEN ABRASIVES
POWER BRUSHES
NYLON BRUSHES

CUTTING WHEELS



Weiler's diverse line of cutting wheels provides consistent, well-balanced, high quality solutions. From our 1-millimeter cutting wheels that slice through metal to our large diameter wheels for the biggest cuts, professionals get the most demanding jobs done right and done fast.

FEATURES:

- Additional fiberglass reinforcement provides **added strength** for aggressive cutting
- Smooth outer layer reduces friction for an **effortless cut and less kickback** during operation
- **2.0** Optimum Use Line helps maximize wheel life, **improving productivity** and sustainability
- **2.0** Longer wheel life **reduces change-overs** and delivers more cuts



UltraCut wheel making precision cuts on steel tube stock.

TYPE 1 1MM CUTTING WHEELS



58006



58131



TYPE 1
7/8" Arbor

P HIGH PERFORMANCE THIN CUTTING

STEEL / METAL TIGER® ZIRC ULTRACUT 1MM / Fast Cut & Long Life

Diameter	Thickness	Grade	Max. RPM	Std. Pack	Item #
4-1/2"	1 mm	Z60T	13,300	50	58005
5"	1 mm	Z60T	12,200	50	58006

STAINLESS TIGER INOX ULTRACUT 1MM / Contaminant-free*

4-1/2"	1 mm	INOX60T	13,300	50	58130
5"	1 mm	INOX60T	12,200	50	58131

*Contaminant-free (Contains less than 0.1% Fe, S, Cl)

CUTS
20%
FASTER
than the closest
competitor

PROPRIETARY
SOLID
CORE
TECHNOLOGY

increases wheel density,
resulting in longer life,
reduced friction and
superior stability

A TRUE
1MM
THICKNESS

delivers precise, consistent
cuts you can count on



TRUE
1 MILLIMETER

STANDARD
.045"

TYPE 1 & 27 CUTTING WHEELS



NEW 2.0 BOLD items only.

P MAX PERFORMANCE CUTTING

STEEL / METAL				TYPE 1 7/8" Arbor		TYPE 27 7/8" Arbor		TYPE 27 5/8"-11 Hub	
STAINLESS				TIGER® CERAMIC		TIGER ZIRC		TIGER ZIRC	
HARD-TO-CUT				Superior Life & Cut		Fast Cut & Long Life		Fast Cut & Long Life	
Contaminant-free*									
Diameter	Thickness	Grade	Max. RPM	Std. Pack	Item #	Std. Pack	Item #	Std. Pack	Item #
4-1/2"	.045"	CER60S	13,300	25	58300	25	58305	10	58306
5"	.045"	CER60S	12,200	25	58301	25	58307	10	58308
6"	.045"	CER60S	10,200	25	58302	25	58309	10	58310
7"	.060"	CER60S	8,600	25	58303	25	58311	10	58312

NEW 2.0 BOLD items only.

P HIGH PERFORMANCE CUTTING

STEEL / METAL				TYPE 1 7/8" Arbor		TYPE 27 7/8" Arbor		TYPE 27 5/8"-11 Hub	
TIGER INOX / Contaminant-free*									
Diameter	Thickness	Grade	Max. RPM	Std. Pack	Item #	Std. Pack	Item #	Std. Pack	Item #
4-1/2"	.045"	Z60T	13,300	25	58000	25	58020	10	58030
5"	.045"	Z60T	12,200	25	58001	25	58021	10	58031
6"	.045"	Z60T	10,200	25	58002	25	58022	10	58032
7"	.060"	Z60T	8,600	25	58003	25	58023	10	58033

STAINLESS				TYPE 1 7/8" Arbor		TYPE 27 7/8" Arbor		TYPE 27 5/8"-11 Hub	
TIGER INOX / Contaminant-free*									
Diameter	Thickness	Grade	Max. RPM	Std. Pack	Item #	Std. Pack	Item #	Std. Pack	Item #
4-1/2"	.045"	INOX60S	13,300	25	58100	25	58110	10	58109
5"	.045"	INOX60S	12,200	25	58101	25	58111	—	—
6"	.045"	INOX60S	10,200	25	58102	25	58112	10	58113
7"	.060"	INOX60S	8,600	25	58103	25	58107	—	—

ALUMINUM				TYPE 1 7/8" Arbor		TYPE 27 7/8" Arbor		TYPE 27 5/8"-11 Hub	
TIGER ALUMINUM / Non-loading / Contaminant-free*									
Diameter	Thickness	Grade	Max. RPM	Std. Pack	Item #	Std. Pack	Item #	Std. Pack	Item #
4-1/2"	.045"	ALU60S	13,300	25	58200	25	58205	10	58206
5"	.045"	ALU60S	12,200	25	58201	—	—	—	—
6"	.045"	ALU60S	10,200	25	58202	25	58209	10	58210
7"	.060"	ALU60S	8,600	25	58203	—	—	—	—

NEW 2.0 BOLD items only.

P PERFORMANCE CUTTING

STEEL / METAL				TYPE 1 7/8" Arbor		TYPE 27 7/8" Arbor		TYPE 27 5/8"-11 Hub	
TIGER AO / Long Life									
Diameter	Thickness	Grade	Max. RPM	Std. Pack	Item #	Std. Pack	Item #	Std. Pack	Item #
4-1/2"	.045"	A60T	13,300	25	57020	25	57041	10	57040
	1/16"	A36T		25	57061	—	—	—	—
	3/32"	A36S		—	—	25	57081	10	57080
5"	.045"	A60T	12,200	25	57021	25	57043	10	57042
	3/32"	A36S		—	—	25	57083	10	57082
6"	.045"	A60T	10,200	25	57022	25	57045	10	57044
7"	.060"	A60T	8,600	25	57023	25	57046	10	57048
9"	1/16"	A60T	6,600	—	—	25	57047	10	57049

V CUTTING

STEEL / METAL				TYPE 1 5/8" Arbor		TYPE 27 5/8" Arbor	
WOLVERINE® AO / Fast Cutting							
Dia.	Thickness	Grade	Max. RPM	Pack	Item #	Pack	Item #
4"	.035"	A60T	15,300	25	56271	—	—
4"	3/32"	A24T	15,200	—	—	25	56474
5"	.035"	A60T	12,200	25	56108	—	—

V CUTTING

STEEL / METAL				TYPE 1 7/8" Arbor		TYPE 27 7/8" Arbor		TYPE 27 5/8"-11 Hub	
WOLVERINE AO / Fast Cutting									
Diameter	Thickness	Grade	Max. RPM	Std. Pack	Item #	Std. Pack	Item #	Std. Pack	Item #
4-1/2"	.045"	A60T	13,300	25	56281	—	—	—	—
	.045"	A60S		—	—	25	56393	—	—
	1/16"	A60T		25	56103	—	—	—	—
	3/32"	A24T		—	—	25	56475	10	56385
5"	.045"	A60S	12,200	—	—	25	56392	—	—
	1/16"	A36T		25	56118	—	—	—	—
	3/32"	A24T		—	—	25	56476	10	56384
6"	.040"	A60T	10,200	25	56282	—	—	—	—
	.045"	A60T		25	56273	—	—	—	—
	.045"	A60S		—	—	25	56283	—	—
	3/32"	A24R		—	—	25	56277	10	56278
7"	.045"	A60T	8,600	25	56275	—	—	—	—
	.060"	A60S		—	—	25	56391	—	—
	3/32"	A24R		—	—	25	56383	10	56477
9"	1/8"	A24T	6,600	—	—	—	—	10	56423



58300



58000



58110



58206



57040



56474



56103

BLACK BOLD ITEM numbers indicate Tiger 2.0. *Contaminant-free (Contains less than 0.1% Fe, S, Cl)

WHY WELER

BONDED ABRASIVES

COATED ABRASIVES

NON-WOVEN ABRASIVES

POWER BRUSHES

NYLON BRUSHES

PACKAGED ITEMS

MAINTENANCE

TYPE 1 SMALL DIAMETER CUTTING WHEELS



58348



58011



57070



56128

P MAX PERFORMANCE CUTTING

STEEL / METAL TIGER® CERAMIC
STAINLESS Superior Life & Cut
HARD-TO-CUT Contaminant-free*

Dia.	Thickness	Grade	Max. RPM	TYPE 1 1/4" Arbor		TYPE 1 3/8" Arbor	
				Pack	Item #	Pack	Item #
3"	1/16"	CER36T	25,000	100	58345	100	58342
4"	1/16"	CER36T	19,000	—	—	25	58348

P HIGH PERFORMANCE CUTTING

STEEL / METAL TIGER ZIRC / Fast Cut & Long Life

Dia.	Thickness	Grade	Max. RPM	TYPE 1 1/4" Arbor		TYPE 1 3/8" Arbor	
				Pack	Item #	Pack	Item #
3"	.035"	Z60T	25,000	100	58012	100	58011
4"	.035"	Z60T	19,000	25	58014	25	58013

P PERFORMANCE CUTTING

STEEL / METAL TIGER AO / Long Life

Dia.	Thickness	Grade	Max. RPM	TYPE 1 1/4" Arbor		TYPE 1 3/8" Arbor	
				Pack	Item #	Pack	Item #
2"	.035"	A60T	30,000	100	57014	100	57010
	1/16"	A36T			57015		57011
	1/8"	A36T			57016		57012
3"	.035"	A60T	25,000	100	—	100	57001
	1/16"	A36T			57066		57060
	1/8"	A36T			57068		57063
4"	.035"	A60T	19,000	25	57075	25	57070
	1/16"	A36T			—		57071
	1/8"	A36T			—		57072

V VALUE CUTTING

STEEL / METAL WOLVERINE® AO / Fast Cut

Dia.	Thickness	Grade	Max. RPM	TYPE 1 1/4" Arbor		TYPE 1 3/8" Arbor	
				Pack	Item #	Pack	Item #
2"	.035"	A60T	30,000	100	56013	100	56128
	1/16"	A36T		100	56015	100	56129
	1/8"	A36S		100	56022	100	56130 •
3"	.035"	A60T	25,000	100	56061	100	56062
	1/16"	A36T		100	56065	100	56068
	1/16"	A60T		—	—	100	56070
	1/8"	A36T		—	—	100	56076
	1/8"	A36S		50	56060	—	—
	1/8"	A36T		—	—	25	56080
4"	.035"	A60T	19,000	25	56165	25	56086
	1/16"	A36T		25	56166 •	25	56086
	1/8"	A36T		—	—	25	56099

TYPE 1 SMALL DIAMETER SNAGGING WHEELS



57064



56064

P PERFORMANCE SNAGGING

STEEL / METAL TIGER AO / Long Life

Diameter	Thickness	Grade	Max. RPM	TYPE 1 3/8" Arbor		TYPE 27 3/8" Arbor	
				Std. Pack	Item #	Std. Pack	Item #
3"	1/4"	A24T	25,000	40	57064	—	—
4"	1/4"	A24T	15,300	10	57073	10	57074

V VALUE SNAGGING

STEEL / METAL WOLVERINE® AO / Fast Cutting

Dia.	Thickness	Grade	Max. RPM	TYPE 1 3/8" Arbor	
				Std. Pack	Item #
2"	1/4"	A36R	30,000	40	56131
3"	1/4"	A24T	25,000	40	56064
4"	1/4"	A36T	15,300	10	56163

• Non-stock product, contact Customer Service for lead times and minimum order quantities.

TYPE 1 FOR CHOP SAWS



P PERFORMANCE CUTTING

STEEL / METAL **TIGER AO** / Long Life

Diameter	Thickness	Arbor	Grade	Description	Max. RPM	Std. Pack	Item #
12"	3/32"	1"	A36T	Long Life Cutting	5,100	10	57090
14"	3/32"	1"	A36T	Long Life Cutting	4,400	10	57092
14"	3/32"	1"	A36R	Smooth Cutting	4,400	10	57093 ◆
14"	3/32"	1"	EA36T	Fast Cut & Long Life	4,400	10	57086
16"	3/32"	1"	A36P	Long Life Cutting	3,850	10	57087

◆ Softer bond for smoother, faster cutting.

TYPE 1

**HIGH
PERFORMANCE**



57086

V CUTTING

STEEL / METAL **WOLVERINE AO** / Fast Cutting

Diameter	Thickness	Arbor	Grade	Description	Max. RPM	Std. Pack	Item #
12"	3/32"	1"	A46T	Fast Cutting	5,100	10	56239
14"	3/32"	1"	A46T	Fast Cutting	4,400	10	56240
14"	3/32"	1"	A46T	Single Center Reinforcement For + Speed	4,400	10	56247

TYPE 1

**RAIL
CUTTING**



58028

TYPE 1 FOR HIGH SPEED SAWS



P HIGH PERFORMANCE CUTTING

STEEL / METAL **TIGER ZIRC** / Fast Cut & Long Life / Rail Cutting

Diameter	Thickness	Arbor	Grade	Description	Max. RPM	Std. Pack	Item #
14"	1/8"	1"	Z24U	Rail Cutting	5,500	10	58028
16"	1/8"	1"	Z24U	Rail Cutting	4,800	10	58029

TYPE 1

P PERFORMANCE CUTTING

STEEL / METAL **TIGER AO** / Long Life

Diameter	Thickness	Arbor	Grade	Description	Max. RPM	Std. Pack	Item #
12"	1/8"	1"	A30T	Long Life Cutting	6,400	10	57030
14"	1/8"	1"	A30T	Long Life Cutting	5,500	10	57032
14"	1/8"	20 mm	A30T	Long Life Cutting	5,500	10	57094
14"	1/8"	20 mm	A30T	Triple Reinforcement For + Support	5,500	10	57035

TYPE 1

**TRIPLE
REINFORCEMENT
FOR + SUPPORT**



57035

TYPE 1 FOR STATIONARY SAWS



P PERFORMANCE CUTTING

STEEL / METAL **TIGER AO** / Long Life

Diameter	Thickness	Arbor	Grade	Description	Max. RPM	Std. Pack	Item #
14"	1/8"	1"	A30R	Long Life Cutting	4,400	10	57091
20"	1/8"	1"	A30S	Long Life Cutting	3,100	10	57097

TYPE 1

V CUTTING

STEEL / METAL **WOLVERINE AO** / Fast Cutting

Diameter	Thickness	Arbor	Grade	Description	Max. RPM	Std. Pack	Item #
14"	1/8"	1"	A30R	Fast Cutting	4,400	10	56230

TYPE 1

GRINDING WHEELS 0 - 45°



Weld blending on a stainless pressure tank with a Tiger Ceramic grinding wheel.

Whether you're looking for serious stock removal, beveling, grinding, or notching, Weiler's grinding will help get the most demanding jobs done right and done fast.

FEATURES:

- Fiberglass cut back design provides **aggressive grinding right out of the box** (Tiger 27 grinding wheels only)
- Triple fiberglass reinforcement increases user safety
- **2.0** Optimum Use Line helps maximize wheel life, **improving productivity** and sustainability
- **2.0** Longer wheel life **reduces change-overs** and removes more material
- **2.0** Advanced 2.0 bond formulation **reduces uneven edge wear and chipping**, improving operator experience and extending wheel life

TYPE 27 GRINDING WHEELS



Cut back provides instant aggressive grinding on new wheels

NEW 2.0 BOLD items only.

P MAX PERFORMANCE GRINDING

STEEL / METAL TIGER® CERAMIC / Superior Life & Cut
STAINLESS Contaminant-free*
HARD-TO-GRIND

Dia.	Thickness	Grade	Max. RPM	TYPE 27 5/8" Arbor		TYPE 27 7/8" Arbor		TYPE 27 5/8"-11 Hub	
				Std. Pack	Item #	Std. Pack	Item #	Std. Pack	Item #
4"	1/4"	CER24R	15,300	10	58335	—	—	—	—
4-1/2"	1/4"	CER24R	13,300	—	—	10	58325	10	58326
5"	1/4"	CER24R	12,200	—	—	10	58327	10	58328
6"	1/4"	CER24R	10,200	—	—	10	58329	10	58330
7"	1/4"	CER24R	8,600	—	—	10	58331	10	58332
9"	1/4"	CER24R	6,600	—	—	10	58333	10	58334



58326

NEW 2.0 BOLD items only.

P HIGH PERFORMANCE GRINDING

STEEL / METAL TIGER ZIRC / Ceramic-infused

Fast Cut & Long Life

Dia.	Thickness	Grade	Max. RPM	TYPE 27 5/8" Arbor		TYPE 27 7/8" Arbor		TYPE 27 5/8"-11 Hub	
				Std. Pack	Item #	Std. Pack	Item #	Std. Pack	Item #
4"	1/4"	Z24T	15,300	10	58069	—	—	—	—
4-1/2"	1/4"	Z24T	13,300	—	—	10	58071	10	58070
5"	1/4"	Z24T	12,200	—	—	10	58073	10	58072
6"	1/4"	Z24T	10,200	—	—	10	58079	10	58078
7"	1/4"	Z24T	8,600	—	—	10	58075	10	58074
9"	1/4"	Z24T	6,650	—	—	10	68384	10	68385

STAINLESS TIGER INOX / Contaminant-free*

4-1/2"	1/4"	INOX24R	13,300	—	—	10	58121	10	58120
5"	1/4"	INOX24R	12,200	—	—	10	58123	10	58122
6"	1/4"	INOX24R	10,200	—	—	10	58129	10	58128 •
7"	1/4"	INOX24R	8,600	—	—	10	58125	10	58124

ALUMINUM TIGER ALUMINUM / Non-loading / Contaminant-free*

4-1/2"	1/4"	ALU24R	13,300	—	—	10	58225	10	58226
5"	1/4"	ALU24R	12,200	—	—	10	58227	10	58228
6"	1/4"	ALU24R	10,200	—	—	10	58229	10	58230



58079



58120



58225

BLACK BOLD ITEM numbers indicate Tiger 2.0. *Contaminant-free (Contains less than 0.1% Fe, S, Cl)

• Non-stock product, contact Customer Service for lead times and minimum order quantities.

NEW 2.0 BOLD items only.

P PERFORMANCE GRINDING

STEEL / METAL TIGER AO / Long Life

Dia.	Thickness	Grade	Max. RPM	TYPE 27 7/8" Arbor		TYPE 27 5/8"-11 Hub	
				Std. Pack	Item #	Std. Pack	Item #
4-1/2"	1/4"	A24R	13,300	10	57121	10	57120
5"	1/4"	A24R	12,200	10	57123	10	57122
6"	1/4"	A24R	10,200	10	57129	10	57128
7"	1/4"	A24R	8,600	10	57125	10	57124
9"	1/4"	A24R	6,650	10	68376	10	68377



57120

V GRINDING

STEEL / METAL WOLVERINE® AO / Fast Cutting

Diameter	Thickness	Grade	Max. RPM	TYPE 27 5/8" Arbor		TYPE 27 7/8" Arbor		TYPE 27 5/8"-11 Hub	
				Std. Pack	Item #	Std. Pack	Item #	Std. Pack	Item #
4"	1/4"	A24R	15,200	10	56473	—	—	—	—
4-1/2"	1/4"	A24R	13,300	—	—	10	56464	10	56454
4-1/2"	1/4"	A24N	13,300	—	—	10	56457	10	56455
5"	1/4"	A24R	12,200	—	—	10	56466	10	56449
6"	1/4"	A24R	10,200	—	—	10	56280	10	56279
7"	1/4"	A24R	8,600	—	—	10	56467	10	56468
9"	1/4"	A24R	6,600	—	—	10	56469	10	56470



56473

TYPE 28 GRINDING WHEELS

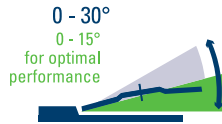

NEW 2.0 BOLD items only.

P HIGH PERFORMANCE GRINDING

STEEL / METAL TIGER® ZIRC / Ceramic-infused

Fast Cut & Long Life

Diameter	Thickness	Grade	Max. RPM	TYPE 28 7/8" Arbor		TYPE 28 5/8"-11 Hub	
				Std. Pack	Item #	Std. Pack	Item #
7"	1/4"	Z24T	8,600	10	58081	10	58080
9"	1/4"	Z24T	6,600	10	58083	10	58082



58081

NEW 2.0 BOLD items only.

P PERFORMANCE GRINDING

STEEL / METAL TIGER AO / Long Life

Diameter	Thickness	Grade	Max. RPM	TYPE 28 7/8" Arbor		TYPE 28 5/8"-11 Hub	
				Std. Pack	Item #	Std. Pack	Item #
7"	1/4"	A24R	8,600	10	57135	10	57134
9"	1/4"	A24R	6,600	10	57137	10	57136



57134

TYPE 29 MILL SCALE GRINDING WHEELS

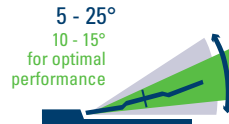

Weiler Tiger mill scale wheels are designed to quickly and efficiently remove mill scale from hot-rolled carbon steel. A circular studded design aggressively cuts through the hard surface and prevents loading or glazing. The wheel's type 29 curved shape increases the contact area, maximizes material removal rates, improves operator comfort, and deters gouging. Its Thin Wheel 2.0 formulation increases life and anchors the zirconia alumina grains, which self-sharpen as the wheel wears, ensuring a consistent, high cut rate for the entire life of the wheel.

These wheels offer a high-performance solution for removing tough mill scale, increasing productivity, ensuring proper coating adhesion, and improving the quality of critical welds.

NEW

P HIGH PERFORMANCE GRINDING

STEEL / METAL TIGER ZIRC / Fast Cut & Long Life

Dia.	Thickness	Grade	Max. RPM	TYPE 29 5/8"-11 Hub	
				Std. Pack	Item #
4-1/2"	1/8"	MILL30T	13,300	10	58086
5"	1/8"	MILL30T	12,200	10	58087
6"	1/8"	MILL30T	10,200	10	58088



58086

WHY WEILER

BONDED ABRASIVES

COATED ABRASIVES

NON-WOVEN ABRASIVES

POWER BRUSHES

NYLON BRUSHES

PACKAGED ITEMS

MAINTENANCE

COMBO WHEELS



Back gouging a steel plate with a Tiger combo wheel.

Weiler's combination wheels offer flexibility and efficiency when switching between cutting and grinding applications.

TYPE 27 CUT & GRIND COMBO WHEELS



NEW 2.0 BOLD items only.

P MAX PERFORMANCE CUT / GRIND COMBO

STEEL / METAL TIGER® CERAMIC
STAINLESS Superior Life & Cut
HARD-TO-GRIND Contaminant-free*

TYPE 27
7/8" Arbor

TYPE 27
5/8"-11 Hub

Diameter	Thickness	Grade	Max. RPM	Std. Pack	Item #	Std. Pack	Item #
4-1/2"	1/8"	CER30T	13,300	25	58315	10	58316
5"	1/8"	CER30T	12,200	25	58317	10	58318
6"	1/8"	CER30T	10,200	25	58319	10	58320
7"	1/8"	CER30T	8,600	25	58321	10	58322
9"	1/8"	CER30T	6,600	25	58323	10	58324

NEW 2.0 BOLD items only.

P HIGH PERFORMANCE CUT / GRIND COMBO

STEEL / METAL TIGER ZIRC / Fast Cut & Long Life

TYPE 27
7/8" Arbor

TYPE 27
5/8"-11 Hub

Diameter	Thickness	Grade	Max. RPM	Std. Pack	Item #	Std. Pack	Item #
4-1/2"	1/8"	Z30T	13,300	25	58051	10	58050
5"	1/8"	Z30T	12,200	25	58053	10	58052
6"	1/8"	Z30T	10,200	25	58064	10	58054
7"	1/8"	Z30T	8,600	25	58056	10	58055
9"	1/8"	Z30T	6,650	25	68382	10	68383

STAINLESS TIGER INOX / Contaminant-free*

4-1/2"	1/8"	INOX30T	13,300	25	58115	10	58114
--------	------	---------	--------	----	--------------	----	--------------

ALUMINUM TIGER ALUMINUM / Non-loading / Contaminant-free*

4-1/2"	1/8"	ALU30T	13,300	25	58215	10	58216
--------	------	--------	--------	----	-------	----	-------

NEW 2.0 BOLD items only.

P PERFORMANCE CUT / GRIND COMBO

STEEL / METAL TIGER AO / Long Life

TYPE 27
7/8" Arbor

TYPE 27
5/8"-11 Hub

Diameter	Thickness	Grade	Max. RPM	Std. Pack	Item #	Std. Pack	Item #
4-1/2"	1/8"	A30S	13,300	25	57101	10	57100
5"	1/8"	A30S	12,200	25	57103	10	57102
6"	1/8"	A30S	10,200	25	57109	10	57108
7"	1/8"	A30S	8,600	25	57105	10	57104
9"	1/8"	A30S	6,650	25	68374	10	68375

V CUT / GRIND COMBO

STEEL / METAL WOLVERINE® AO / Fast Cutting

TYPE 27
7/8" Arbor

TYPE 27
5/8"-11 Hub

Diameter	Thickness	Grade	Max. RPM	Std. Pack	Item #	Std. Pack	Item #
4-1/2"	1/8"	A24T	13,300	25	56430	10	56429
5"	1/8"	A24T	12,200	25	56428	10	56427
7"	1/8"	A24T	8,600	25	56426	10	56425
9"	1/8"	A24T	6,600	25	56424	10	56423

56425

BLACK BOLD ITEM numbers indicate Tiger 2.0. *Contaminant-free (Contains less than 0.1% Fe, S, Cl)

PIPELINE WHEELS

TYPE 27 FOR PIPELINE



Weiler's Pipeline Grinding Wheels are designed specifically for pipeline applications. Whether grinding a bead, facing the land, prepping transitions, or fabricating in the yard, this wheel is ready to work out of the box, delivering consistent, aggressive grinding throughout the life of the wheel, eliminating the need to chip it.

FEATURES:

- **Do Not Chip** – Operators will no longer feel the need to chip the wheel to get it to bite.
- **Reduced Chatter** – A unique bond formulation delivers reduced vibration for the entire life of the wheel for a better grinding experience.
- **Superior Life & Cut** – A blend of zirconia alumina and ceramic grains bite into the bead and dig out the wagon tracks fast while the strong bond delivers long wheel life.

One Wheel for

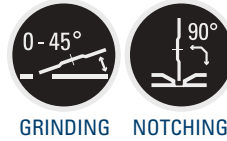

GRINDING NOTCHING

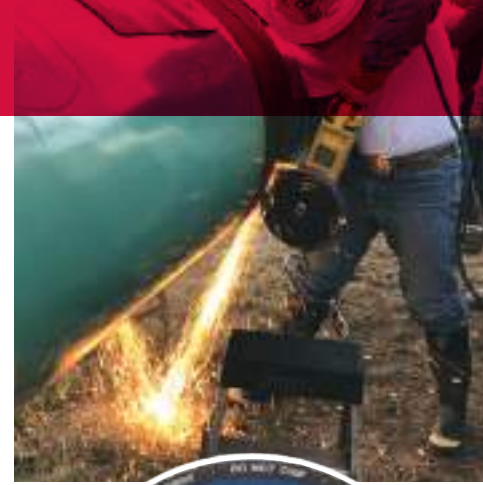

58094

P HIGH PERFORMANCE PIPELINE GRINDING WHEELS

STEEL / METAL TIGER® ZIRC / Ceramic-infused / Fast Grinding & Long Life on Pipe

Diameter	Thickness	Grade	Max. RPM	Std. Pack	Item #
4-1/2"	1/8"	Z30T	13,300	10	58090
6"	1/8"	Z30T	10,200	10	58092
7"	1/8"	Z30T	8,600	10	58094
9"	1/8"	Z30T	6,600	10	58095



TYPE 27 FOR MECHANIZED PIPE WELDING



Weiler's Tiger Mech Wheels are designed for notching applications on mechanical pipe welds. These high-performance wheels are thinner than standard pipe notching wheels, allowing the operator to grind the bead without widening or scarring the bevel.

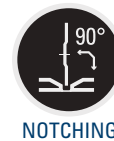

NOTCHING



58066

P HIGH PERFORMANCE MECH NOTCHING WHEELS

STEEL / METAL TIGER ZIRC / Ceramic-infused / Notching Mechanized Pipe Welds

Diameter	Thickness	Grade	Max. RPM	Std. Pack	Item #
4-1/2"	3/32"+	Z30T	13,300	10	58066
7"	3/32"+	Z30T	8,600	10	58068

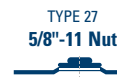

+ Specific size for mechanized pipe welds

ACCESSORIES

ADAPTING NUTS & SPANNER WRENCH For 4" - 6" Angle Grinders.

Description	Adapts To	Min. Wheel Thickness	Standard Pack	Item Number
Adapting Nuts	5/8" to 3/8"-24	.045"	1	56484
Adapting Nuts	7/8" to 5/8"-11	.045"	1	56494
Spanner Wrench	-	-	1	56495



56495

MOUNTING MANDRELS 1/4" Stem. For Type 1 Wheels Only.

Arbor Size	Wheel Thickness	Standard Pack	Item Number
1/4"	1/8" to 1/4"	10	56489
3/8"	1/8" to 1/4"	10	56490
1/4", 3/8" *	1/8" to 1/4"	10	56491*

*Combination pack



56489

ADAPTER for mounting Large Cutting Wheels onto a 20mm arbor.

For Arbor Hole Size	Adapted Arbor Hole Size	Standard Pack	Item Number
1"	20mm	10	04455



04455

NON-WOVEN ABRASIVES

POWER BRUSHES

NYLON BRUSHES

PACKAGED ITEMS

MAINTENANCE

CUPS, CONES & PLUGS – FOR METAL FABRICATION



Type 11 Cup Rock for snagging and heavy stock removal.

TYPE 11 FOR GRINDERS

BEST ON: Carbon steel, stainless steel, cast iron and ductile iron.



68352



68356



73054

CUP FEATURES:

- Precision balanced to ensure smooth **vibration free operation** and reduced operator fatigue
- Zinc plated nut prevents oxidation, eliminating contamination and allowing for easy mounting
- Unique anchored safety nut locks the nut in place to **increase safety and prevent product breakage**

APPLICATIONS:

Ideal for heavy metal removal, grinding, transitioning, rough beveling and removing cracks/flaws



TYPE 11 FLARING CUP WHEELS

HIGH PERFORMANCE GRINDING

STEEL / METAL TIGER ZIRC / Fast Cut & Long Life

Diameter (D / J)	Thickness (T)	Arbor (H)	Rim (W)	Back (E)	Grade	Max. RPM	Std. Pack	Item #
4" / 3"	2"	5/8"-11	3/4"	3/4"	ZA16Q	9,070	5	68352
5" / 3-3/4"	2"	5/8"-11	1"	3/4"	ZA16Q	7,260	5	68355
6" / 4-3/4"	2"	5/8"-11	1"	3/4"	ZA16Q	6,000	5	68358
6" / 4-3/4"	2"	5/8"-11	1-1/2"	3/4"	ZAC16Q	6,000	5	68361+
6" / 4-3/4"	2"	5/8"-11	1-1/2"	3/4"	ZA16R	6,000	5	68362
6" / 4-3/4"	2"	5/8"-11	1-1/2"	3/4"	ZA16Q	6,000	5	68364

+ Includes silicon carbide for burnt-in sand and hard-to-grind metals.

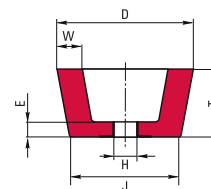

PERFORMANCE GRINDING

STEEL / METAL TIGER AO / Long Life

Diameter (D / J)	Thickness (T)	Arbor (H)	Rim (W)	Back (E)	Grade	Max. RPM	Std. Pack	Item #
4" / 3"	2"	5/8"-11	3/4"	3/4"	A16Q	9,070	5	68350
5" / 3-3/4"	2"	5/8"-11	1"	3/4"	A16Q	7,260	5	68353
6" / 4-3/4"	2"	5/8"-11	1"	3/4**	A16Q	6,000	5	68356
6" / 4-3/4"	2"	5/8"-11	1-1/2"	3/4**	A16Q	6,000	5	68359

*Reinforced metal back

CUP WHEEL MOUNTING FLANGE - Fits over 5/8"-11 spindles

Diameter	Thickness	Std. Pack	Item #
2"	1/4"	1	73054

ANCHORED NUT INCREASES SAFETY

Our testing shows that the Weiler anchored safety nut outperformed the industry standard metal back:

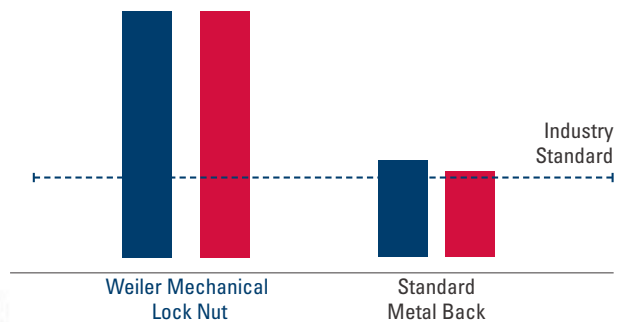

- ▶ Up to 3X higher torque holding strength
- ▶ Double speed burst testing ratings

CONES AND PLUGS FOR STRAIGHT & DIE GRINDERS



CONE & PLUG FEATURES:

- Open face design provides aggressive cut rate right out of the box
- Anchored hexagon nut secures the abrasive to the tool to increase safety and prevent product breakage
- Precision balanced to ensure smooth, **vibration free operation** and reduced operator fatigue

APPLICATIONS:

Ideal for ID cleaning, hole edge beveling, smoothing weld seams, removing gates and parting lines and cleaning castings in hard-to-reach places



Type 18R plug used to grind I.D. bevels and flatten surface on rail frog section.

TYPE 16 CONES

P HIGH PERFORMANCE GRINDING

STEEL / METAL TIGER ZIRC TYPE 16 CONES / Fast Cut & Long Life

Diameter (D)	Thickness (T)	Arbor (Thread)	Grade	Max. RPM	Std. Pack	Item #
1"	3"	3/8"-24 Nut	ZA20S	36,290	12	68301
1-1/2"	2-1/2"	5/8"-11 Nut	ZA20S	24,190	12	68304
1-1/2"	2"	3/8"-24 Nut	ZA20S	24,190	12	68306
1-1/2"	3"	5/8"-11 Nut	ZA20S	24,190	12	68308
2"	3"	5/8"-11 Nut	ZA20S	18,145	12	68311
2-3/4"	3-1/2"	5/8"-11 Nut	ZA20S	13,195	12	68313

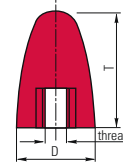

P PERFORMANCE GRINDING **STEEL / METAL** TIGER AO / Long Life

Diameter (D)	Thickness (T)	Arbor (Thread)	Grade	Max. RPM	Std. Pack	Item #
1-1/2"	2-1/2"	5/8"-11 Nut	A24R	24,190	12	68303
1-1/2"	3"	3/8"-24 Nut	A24R	24,190	12	68305
1-1/2"	3"	5/8"-11 Nut	A24R	24,190	12	68307
2"	3"	3/8"-24 Nut	A24R	18,145	12	68309
2"	3"	5/8"-11 Nut	A24R	18,145	12	68310
2-3/4"	3"	5/8"-11 Nut	A24R	13,195	12	68312
3"	3"	5/8"-11 Nut	A24R	12,100	12	68314



TYPE 17 CONES

P HIGH PERFORMANCE GRINDING

STEEL / METAL TIGER ZIRC TYPE 17 CONES / Fast Cut & Long Life

Diameter (D)	Thickness (T)	Arbor (Thread)	Grade	Max. RPM	Std. Pack	Item #
2"	3"	5/8"-11 Nut	ZA20S	18,145	12	68365

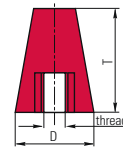

P PERFORMANCE GRINDING **STEEL / METAL** TIGER AO / Long Life

Diameter (D)	Thickness (T)	Arbor (Thread)	Grade	Max. RPM	Std. Pack	Item #
1-3/4"	3"	5/8"-11 Nut	A24R	20,740	12	68316
2"	3"	5/8"-11 Nut	A24R	18,145	12	68317

TYPE 18 PLUGS

P HIGH PERFORMANCE GRINDING

STEEL / METAL TIGER ZIRC TYPE 18 PLUGS / Fast Cut & Long Life

Diameter (D)	Thickness (T)	Arbor (Thread)	Grade	Max. RPM	Std. Pack	Item #
1-1/2"	2-1/2"	5/8"-11 Nut	ZA20S	24,190	12	68320
1-1/2"	3"	5/8"-11 Nut	ZA20S	24,190	12	68322
2"	3"	5/8"-11 Nut	ZA20S	18,145	12	68324

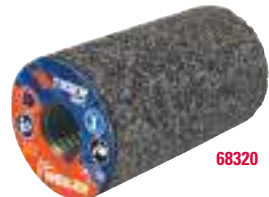
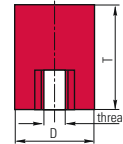

P PERFORMANCE GRINDING **STEEL / METAL** TIGER AO / Long Life

Diameter (D)	Thickness (T)	Arbor (Thread)	Grade	Max. RPM	Std. Pack	Item #
1-1/2"	2-1/2"	3/8"-24 Nut	A24R	24,190	12	68318
1-1/2"	2-1/2"	5/8"-11 Nut	A24R	24,190	12	68319
1-1/2"	3"	5/8"-11 Nut	A24R	24,190	12	68321
2"	3"	5/8"-11 Nut	A24R	18,145	12	68323

TYPE 18R PLUGS

P HIGH PERFORMANCE GRINDING

STEEL / METAL TIGER ZIRC TYPE 18R PLUGS / Fast Cut & Long Life

Diameter (D)	Thickness (T)	Arbor (Thread)	Grade	Max. RPM	Std. Pack	Item #
1-1/2"	3"	3/8"-24 Nut	ZA20S	24,190	12	68326
1-1/2"	3"	5/8"-11 Nut	ZA20S	24,190	12	68328
2"	3"	5/8"-11 Nut	ZA20S	18,145	12	68330

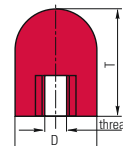

P PERFORMANCE GRINDING **STEEL / METAL** TIGER AO / Long Life

Diameter (D)	Thickness (T)	Arbor (Thread)	Grade	Max. RPM	Std. Pack	Item #
1-1/2"	3"	5/8"-11 Nut	A24R	24,190	12	68327
2"	3"	5/8"-11 Nut	A24R	18,145	12	68329
3"	3"	5/8"-11 Nut	A24R	12,100	12	68331

BONDED ABRASIVES

COATED ABRASIVES

NON-WOVEN ABRASIVES

POWER BRUSHES

NYLON BRUSHES

PACKAGED ITEMS

MAINTENANCE

JOIN THE NEXT **REVOLUTION** IN FOUNDRY GRINDING

The finishing process in foundries is a tough job. For decades, abrasives technology for off-hand grinding has remained unchanged. It's time for improvement, faster grinding rates, decreased cycle times and an improved operator experience. It's time for a revolution.

As an industry leader and global manufacturer of surface conditioning solutions, Weiler Abrasives is driven to help you overcome the toughest cleaning, grinding, cutting, deburring and finishing challenges. That's why we created a line of abrasives specifically designed to deliver maximum performance in foundry applications. From gate removal to id-cleaning, Weiler offers the right product solutions and expertise to help you find production and process efficiencies in your cleaning room.

Weiler Foundry Products — A **REVOLUTION** in foundry grinding.

LEARN MORE:



WE PROVIDE VALUE THROUGH:

- ▶ *Ground Breaking Abrasive Technology For Foundry Applications*
- ▶ *Enhanced Safety Features*
- ▶ *Improved Operator Experience*
- ▶ *Expert Abrasives On-Site Technical Support*
- ▶ *Product Available When You Need It*
- ▶ *Custom Engineered Solutions*
- ▶ *Maximum Productivity*
- ▶ *Lowest Cost Of Use*



PRODUCT SELECTION

WHY WEILER

BONDED ABRASIVES

COATED ABRASIVES

NON-WOVEN ABRASIVES

POWER BRUSHES

NYLOX BRUSHES

PACKAGED ITEMS

MAINTENANCE

P **MAX PERFORMANCE**
SUPERIOR LIFE & CUT

CUT RATE: ●●●●●
LIFE: ●●●●●



TIGER® CERAMIC
Self-sharpening ceramic alumina grains provide ultra-high metal removal rates and optimal productivity.

GRAIN TYPE
Ceramic alumina

BEST ON
CAST IRON **DUCTILE IRON**
CAST STEEL **HARD-TO-GRIND**
 white iron, gray iron, high nickel alloy and stainless steel

P **HIGH PERFORMANCE**
FAST CUT & LONG LIFE

CUT RATE: ●●●●○
LIFE: ●●●●●



TIGER ZIRC
Sharp and durable zirconia alumina grains provide fast and consistent metal removal rates throughout the life of the abrasive.

GRAIN TYPE
Zirconia alumina

BEST ON
CAST IRON **DUCTILE IRON**
CAST STEEL
 white iron, gray iron, high nickel alloy and stainless steel

P **PERFORMANCE**
LONG LIFE

CUT RATE: ●●●●○
LIFE: ●●●●●



TIGER SiC
Silicon carbide grains provide a consistent, controlled cut rate on sand castings with burnt-in sand.

GRAIN TYPE
Silicon carbide

BEST ON
BURNT IN SAND



TIGER AO
Aluminum oxide grains provide an even, sharp, clean cut rate and consistent performance.

GRAIN TYPE
Aluminum oxide

BEST ON
CAST IRON
ductile iron, carbon steel and stainless steel

Key:
P PERFORMANCE LINE
Industrial Grade

Read and Comply with ANSI B7.1

TYPE 11 CUP WHEELS



Type 11 Cup Rock for snagging and heavy stock removal.

Weiler Tiger type 11 flaring cup grinding wheels deliver the next evolution in technology for portable foundry grinding. From Tiger Ceramic, which provides superior productivity, to Tiger SiC for castings with burnt-in sand, our line offers the performance you need to get the job done fast.

CUP FEATURES:

- Precision balanced to ensure smooth, **vibration-free operation** and reduced operator fatigue
- Unique anchored safety nut locks the cup in place to **increase safety** and prevent product breakage
- Zinc plated 5/8"-11 nut prevents oxidation, eliminating contamination and allows for easy spin-on, spin-off changeover

APPLICATIONS:

Ideal for heavy metal removal, grinding, transitioning, rough beveling and removing cracks/flaws.



Type 11 Cup

0 - 15°
for optimal
performance



RIM (W) WIDTH OPTIONS

1-1/2" RIM	Large grinding zone to minimize grind time
1" RIM	Medium grinding zone for maximum material removal in targeted areas
3/4" RIM	Ideal for targeted material removal in small, hard-to-access areas

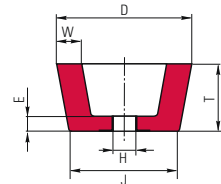

68400



68352



68354



68356

P MAX PERFORMANCE GRINDING

CAST IRON	DUCTILE IRON	CAST STEEL	HARD-TO-GRIND	TIGER CERAMIC / Superior Life & Cut					
Diameter (D / J)	Thickness (T)	Arbor (H)	Rim (W)	Back (E)	Grade	Max. RPM	Std. Pack	Item #	
6" / 4-3/4"	2"	5/8"-11	1-1/2"	3/4"	HZA16Q	6,000	5	68400	

P HIGH PERFORMANCE GRINDING

CAST IRON	DUCTILE IRON	CAST STEEL	TIGER ZIRC / Fast Cut & Long Life					
Diameter (D / J)	Thickness (T)	Arbor (H)	Rim (W)	Back (E)	Grade	Max. RPM	Std. Pack	Item #
4" / 3"	2"	5/8"-11	3/4"	3/4"	ZA16Q	9,070	5	68352
5" / 3-3/4"	2"	5/8"-11	1"	3/4"	ZA16Q	7,260	5	68355
6" / 4-3/4"	2"	5/8"-11	1"	3/4"	ZA16Q	6,000	5	68358
6" / 4-3/4"	2"	5/8"-11	1-1/2"	3/4"	ZAC16Q	6,000	5	68361+
6" / 4-3/4"	2"	5/8"-11	1-1/2"	3/4"	ZA16R	6,000	5	68362
6" / 4-3/4"	2"	5/8"-11	1-1/2"	3/4"	ZA16Q	6,000	5	68364

P PERFORMANCE GRINDING

BURNT IN SAND	TIGER SiC / Long Life							
Diameter (D / J)	Thickness (T)	Arbor (H)	Rim (W)	Back (E)	Grade	Max. RPM	Std. Pack	Item #
4" / 3"	2"	5/8"-11	3/4"	3/4"	C16Q	9,070	5	68351
5" / 3-3/4"	2"	5/8"-11	1"	3/4"	C16Q	7,260	5	68354
6" / 4-3/4"	2"	5/8"-11	1"	3/4"	C16Q	6,000	5	68357 •
6" / 4-3/4"	2"	5/8"-11	1-1/2"	3/4"	C16Q	6,000	5	68069

CAST IRON	TIGER AO / Long Life							
Diameter (D / J)	Thickness (T)	Arbor (H)	Rim (W)	Back (E)	Grade	Max. RPM	Std. Pack	Item #
4" / 3"	2"	5/8"-11	3/4"	3/4"	A16Q	9,070	5	68350
5" / 3-3/4"	2"	5/8"-11	1"	3/4"	A16Q	7,260	5	68353
6" / 4-3/4"	2"	5/8"-11	1"	3/4"	A16Q	6,000	5	68356
6" / 4-3/4"	2"	5/8"-11	1-1/2"	3/4"	A16Q	6,000	5	68359
6" / 4-3/4"	2"	5/8"-11	1-1/2"	3/4"	AC16Q	6,000	5	68360+ •

+ Includes silicon carbide for burnt-in sand and hard-to-grind metals.

• Non-stock product, contact Customer Service for lead times and minimum order quantities.

FLARING CUP WHEEL MOUNTING FLANGE

Fits over 5/8"-11 spindles

Diameter	Thickness	Std. Pack	Item #
2"	1/4"	1	73054



73054

SAFETY WARNING: Using a flaring cup wheel without the proper flange is a violation of ANSI code.

TYPE 27 GRINDING WHEELS

Weiler Tiger type 27 grinding wheels deliver the next evolution in technology for portable foundry grinding. The line is available in three performance tiers, including Tiger Ceramic which sets a new standard for maximum performance. The ceramic grain leverages an engineered ultra-fine microstructure that self-sharpenes for ultra-fast grinding. This technology allows Tiger Ceramic to remove up to 40% more material over the life of the wheel compared to competitive zirconia products. This translates to better productivity in the cleaning room and a reduction in abrasives usage.

GRINDING WHEEL FEATURES:

- Advanced anti-chipping technology **improves safety** through the reduction of high energy debris emitted during the grinding process
- 5/8"-11 nitted metal hub allows for quick spin-on, spin-off changeover and eliminates cross-threading or sticking to spindle due to heat build-up
- Triple fiberglass reinforcement for added strength
- 1/8" combo wheels offer flexibility and efficiency when switching between cutting and grinding applications



Tiger Foundry wheel removing excess material from a casting.



1/4" GRINDING WHEELS:

Ideal for heavy stock removal, removing cracks and surface imperfections, blending parting lines, removing flash, gates and risers.

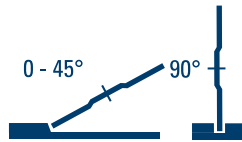

1/8" COMBO WHEELS:

Ideal for light grinding, blending parting lines, removing flash and cutting gates and risers.

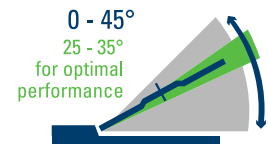

P MAX PERFORMANCE

TIGER CERAMIC / Superior Cut & Long Life

Diameter	Thickness	Grade	Max. RPM	Std. Pack	Item #	Std. Pack	Item #
Type 27 Depressed Center 1/4" Grinding Wheels							
7"	1/4"	CER24T	8,600	10	68388	10	68389
9"	1/4"	CER24T	6,650	10	68392	10	68393
Type 27 Depressed Center 1/8" Cut & Grind Combo Wheels							
7"	1/8"	CER30T	8,600	25	68386	10	68387
9"	1/8"	CER30T	6,650	25	68390	10	68391

TYPE 27
7/8" Arbor

TYPE 27
5/8"-11 Hub



68389

P HIGH PERFORMANCE

TIGER ZIRC / Fast Cut & Long Life

Diameter	Thickness	Grade	Max. RPM	Std. Pack	Item #	Std. Pack	Item #
Type 27 Depressed Center 1/4" Grinding Wheels							
7"	1/4"	Z24T	8,600	10	68380	10	68381
9"	1/4"	Z24T	6,650	10	68384	10	68385
Type 27 Depressed Center 1/8" Cut & Grind Combo Wheels							
7"	1/8"	Z30T	8,600	25	68378	10	68379
9"	1/8"	Z30T	6,650	25	68382	10	68383

TYPE 27
7/8" Arbor

TYPE 27
5/8"-11 Hub



68380

P PERFORMANCE

TIGER AO / Long Life

Diameter	Thickness	Grade	Max. RPM	Std. Pack	Item #	Std. Pack	Item #
Type 27 Depressed Center 1/4" Grinding Wheels							
7"	1/4"	A24T	8,600	10	68372	10	68373
9"	1/4"	A24T	6,650	10	68376	10	68377
Type 27 Depressed Center 1/8" Cut & Grind Combo Wheels							
7"	1/8"	A30T	8,600	25	68370	10	68371
9"	1/8"	A30T	6,650	25	68374	10	68375

TYPE 27
7/8" Arbor

TYPE 27
5/8"-11 Hub



68370

BONDED ABRASIVES

COATED ABRASIVES

NON-WOVEN ABRASIVES

POWER BRUSHES

NYLON BRUSHES

PACKAGED ITEMS

MAINTENANCE

CONES & PLUGS - FOR FOUNDRY



Weiler Tiger cones and plugs offer performance grinding solutions for ID cleaning, hole edge beveling, smoothing weld seams, removing parting lines and cleaning castings in hard-to-reach places. Designed with the operator in mind, these abrasives provide smooth, vibration free operation and instant cutting action right out of the box.



Using a cone to clean surface imperfections.

CONE & PLUG FEATURES:

- Open face design provides **aggressive cut rate** right out of the box
- Anchored hexagon nut secures the abrasive to the tool to **increase safety** and prevent product breakage
- Zinc plated nut prevents oxidation, eliminates contamination and allows for easy mounting
- Precision balanced to ensure smooth, **vibration free operation** and reduced operator fatigue

APPLICATIONS:

Ideal for ID cleaning, hole edge beveling, smoothing weld seams, removing parting lines and cleaning castings in hard-to-reach places.

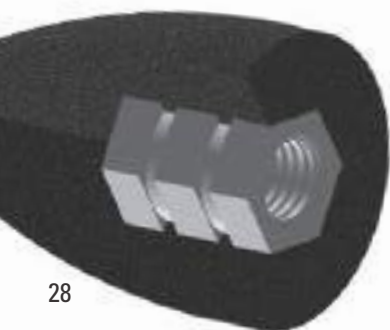
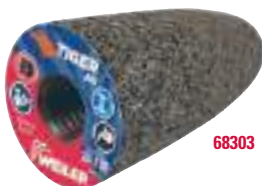
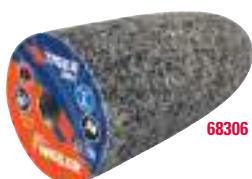
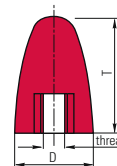
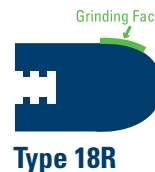
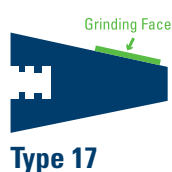

P MAX PERFORMANCE GRINDING

CAST IRON DUCTILE IRON CAST STEEL HARD-TO-GRIND

TIGER CERAMIC TYPE 16 CONES / Superior Life & Cut

Diameter (D)	Thickness (T)	Arbor (Thread)	Grade	Max. RPM	Std. Pack	Item #
2"	3"	5/8"-11 Nut	HZA20S	18,145	12	68403

P HIGH PERFORMANCE GRINDING

CAST IRON DUCTILE IRON CAST STEEL TIGER ZIRC TYPE 16 CONES / Fast Cut & Long Life

Diameter (D)	Thickness (T)	Arbor (Thread)	Grade	Max. RPM	Std. Pack	Item #
1"	3"	3/8"-24 Nut	ZA20S	36,290	12	68301
1-1/2"	2-1/2"	5/8"-11 Nut	ZA20S	24,190	12	68304
1-1/2"	2"	3/8"-24 Nut	ZA20S	24,190	12	68306
1-1/2"	3"	5/8"-11 Nut	ZA20S	24,190	12	68308
2"	3"	5/8"-11 Nut	ZA20S	18,145	12	68311
2-3/4"	3-1/2"	5/8"-11 Nut	ZA20S	13,195	12	68313

P PERFORMANCE GRINDING

CAST IRON TIGER A0 TYPE 16 CONES / Long Life

Diameter (D)	Thickness (T)	Arbor (Thread)	Grade	Max. RPM	Std. Pack	Item #
1-1/2"	2-1/2"	5/8"-11 Nut	A24R	24,190	12	68303
1-1/2"	3"	3/8"-24 Nut	A24R	24,190	12	68305
1-1/2"	3"	5/8"-11 Nut	A24R	24,190	12	68307
2"	3"	3/8"-24 Nut	A24R	18,145	12	68309
2"	3"	5/8"-11 Nut	A24R	18,145	12	68310
2-3/4"	3"	5/8"-11 Nut	A24R	13,195	12	68312
3"	3"	5/8"-11 Nut	A24R	12,100	12	68314

ANCHORED NUT INCREASES SAFETY

- Heavy-duty steel hex nut fully anchored into abrasive bond prevents separation and slippage during use.

P **MAX PERFORMANCE GRINDING**
 CAST IRON DUCTILE IRON CAST STEEL **HARD-TO-GRIND**
TIGER CERAMIC TYPE 17 CONES / Superior Life & Cut

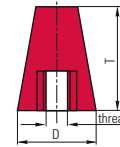

Diameter (D)	Thickness (T)	Arbor (Thread)	Grade	Max. RPM	Std. Pack	Item #
2"	3"	5/8"-11 Nut	HZA20S	18,145	12	68404



P **HIGH PERFORMANCE GRINDING**
 CAST IRON DUCTILE IRON CAST STEEL **TIGER ZIRC TYPE 17 CONES** / Fast Cut & Long Life

Diameter (D)	Thickness (T)	Arbor (Thread)	Grade	Max. RPM	Std. Pack	Item #
2"	3"	5/8"-11 Nut	ZA20S	18,145	12	68365



P **PERFORMANCE GRINDING**
 CAST IRON **TIGER AO TYPE 17 CONES** / Long Life

Diameter (D)	Thickness (T)	Arbor (Thread)	Grade	Max. RPM	Std. Pack	Item #
1-3/4"	3"	5/8"-11 Nut	A24R	20,740	12	68316
2"	3"	5/8"-11 Nut	A24R	18,145	12	68317

P **MAX PERFORMANCE GRINDING**
 CAST IRON DUCTILE IRON CAST STEEL **HARD-TO-GRIND**
TIGER CERAMIC TYPE 18 PLUGS / Superior Life & Cut

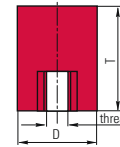

Diameter (D)	Thickness (T)	Arbor (Thread)	Grade	Max. RPM	Std. Pack	Item #
2"	3"	5/8"-11 Nut	HZA20S	18,145	12	68405



P **HIGH PERFORMANCE GRINDING**
 CAST IRON DUCTILE IRON CAST STEEL **TIGER ZIRC TYPE 18 PLUGS** / Fast Cut & Long Life

Diameter (D)	Thickness (T)	Arbor (Thread)	Grade	Max. RPM	Std. Pack	Item #
1-1/2"	2-1/2"	5/8"-11 Nut	ZA20S	24,190	12	68320
1-1/2"	3"	5/8"-11 Nut	ZA20S	24,190	12	68322
2"	3"	5/8"-11 Nut	ZA20S	18,145	12	68324

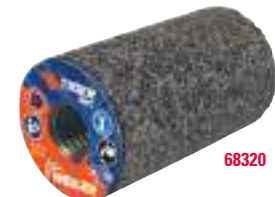

P **PERFORMANCE GRINDING**
 CAST IRON **TIGER AO TYPE 18 PLUGS** / Long Life

Diameter (D)	Thickness (T)	Arbor (Thread)	Grade	Max. RPM	Std. Pack	Item #
1-1/2"	2-1/2"	3/8"-24 Nut	A24R	24,190	12	68318
1-1/2"	2-1/2"	5/8"-11 Nut	A24R	24,190	12	68319
1-1/2"	3"	5/8"-11 Nut	A24R	24,190	12	68321
2"	3"	5/8"-11 Nut	A24R	18,145	12	68323

P **MAX PERFORMANCE GRINDING**
 CAST IRON DUCTILE IRON CAST STEEL **HARD-TO-GRIND**
TIGER CERAMIC TYPE 18R PLUGS / Superior Life & Cut

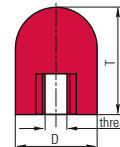

Diameter (D)	Thickness (T)	Arbor (Thread)	Grade	Max. RPM	Std. Pack	Item #
2"	3"	5/8"-11 Nut	HZA20S	18,145	12	68406



P **HIGH PERFORMANCE GRINDING**
 CAST IRON DUCTILE IRON CAST STEEL **TIGER ZIRC TYPE 18R PLUGS** / Fast Cut & Long Life

Diameter (D)	Thickness (T)	Arbor (Thread)	Grade	Max. RPM	Std. Pack	Item #
1-1/2"	3"	3/8"-24 Nut	ZA20S	24,190	12	68326
1-1/2"	3"	5/8"-11 Nut	ZA20S	24,190	12	68328
2"	3"	5/8"-11 Nut	ZA20S	18,145	12	68330



P **PERFORMANCE GRINDING**
 CAST IRON **TIGER AO TYPE 18R PLUGS** / Long Life

Diameter (D)	Thickness (T)	Arbor (Thread)	Grade	Max. RPM	Std. Pack	Item #
1-1/2"	3"	5/8"-11 Nut	A24R	24,190	12	68327
2"	3"	5/8"-11 Nut	A24R	18,145	12	68329
3"	3"	5/8"-11 Nut	A24R	12,100	12	68331

SNAGGING WHEELS - FOR FOUNDRY



Portable snagging wheels are ideal for targeted heavy stock removal applications.

Weiler Tiger type 1 portable snagging wheels feature a flat face with a narrow contact area, making them ideal for heavy grinding, transitioning, rough beveling, and removing cracks and flaws. The line is available in three performance tiers, including Tiger Zirc, which provides an excellent combination of long product life and a fast, consistent cut rate when grinding.

Tiger 6 & 8 inch snagging wheels are designed for medium to high power pneumatic and high frequency electric straight grinders, while the 3 inch wheels are used on die grinders. The arbor hole is produced with a precision phenolic resin insert to ensure a tight fit on the tool, minimizing vibration and enhancing the operator experience.

FEATURES:

- Open face design provides **aggressive cut rate** right out of the box
- Precision balanced to ensure smooth, **vibration-free operation** and reduced operator fatigue
- Double fiberglass internal reinforcement in 6 & 8 inch wheels provide added strength for **consistent product wear and reduced edge chipping**

APPLICATIONS:

Ideal for snagging, grinding, heavy stock removal, transitioning, rough beveling, removing cracks and flaws, blending parting lines and deflashing.

Type 1 (Flat)



Features a flat face with narrow contact area



68402



68342



68340

P MAX PERFORMANCE SNAGGING

CAST IRON DUCTILE IRON TIGER CERAMIC
CAST STEEL HARD-TO-GRIND Superior Life & Cut

TYPE 1
5/8" Arbor

Diameter	Thickness	Grade	Max. RPM	Std. Pack	Item #
6"	1"	HZR16-R	8,000	5	68401
8"	1"	HZR16-R	6,000	5	68402 •

P HIGH PERFORMANCE SNAGGING

CAST IRON DUCTILE IRON TIGER ZIRC
CAST STEEL Fast Cut & Long Life

TYPE 1
3/8" Arbor

TYPE 1
5/8" Arbor

Diameter	Thickness	Grade	Max. RPM	Std. Pack	Item #	Std. Pack	Item #
3"	1/2"	ZA14S	18,080	10	68341	—	—
6"	1"	ZA16Q	8,000	—	—	5	68342
6"	1"	ZAC16Q	8,000	—	—	5	68343+
6"	1"	ZA16R	8,000	—	—	5	68344
8"	1"	ZA16O	6,000	—	—	5	68345 •
8"	1"	ZA16Q	6,000	—	—	5	68346
8"	1"	ZAC16Q	6,000	—	—	5	68347+ •
8"	1"	ZA16R	6,000	—	—	5	68348
8"	1"	ZA16T	6,000	—	—	5	68349

+ Includes silicon carbide for burnt-in sand and hard-to-grind metals.

P PERFORMANCE GRINDING

CAST IRON TIGER AO / Long Life

TYPE 1
3/8" Arbor

Diameter	Thickness	Grade	Max. RPM	Std. Pack	Item #
3"	1/2"	A14P	18,080	10	68340

• Non-stock product, contact Customer Service for lead times and minimum order quantities.

MOUNTED POINTS - FOR FOUNDRY



Weiler Tiger Zirc mounted points come in various ANSI point shapes including A1, A11, A3, and W. A zirconia abrasive grain in combination with a strong bond delivers long product life and a consistent cut rate when grinding metal. The unique shapes allow for precise cleaning and grinding of parts with complex geometries and in hard-to-reach areas. Designed for die grinders, mounted points have a standard 1/4" shank diameter and a 1-1/2" shank length.

FEATURES:

- Dressed working surface **eliminates break-in** and provides a consistent finish
- Engineered stem bonding **adds strength and stability** to the point, improving safety
- Tailored product geometry provides **optimal control** for precise grinding of critical parts

APPLICATIONS:

Ideal for cleaning ID's, corners and hard-to-reach areas, edge chamfering, light grinding, stock removal and hole edge beveling.



Tiger mounted points are ideal for light grinding in hard-to-reach areas and removing cracks from castings.

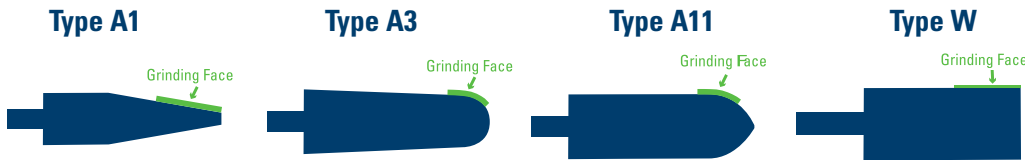

P HIGH PERFORMANCE GRINDING

CAST IRON DUCTILE IRON CAST STEEL

TIGER ZIRC / Fast Cut & Long Life

Diameter	Length	Shape	Grade	Max. RPM	Std. Pack	Item #
3/4"	1/2"	A1	RZA24U	19,800	10	68332
7/8"	2"	A11	RZA24U	19,860	10	68333
1"	2-3/4"	A3	RZA24U	16,100	10	68334
1/2"	2"	W189	RZA24U	24,000	10	68335
3/4"	1-1/2"	W207	RZA24U	24,000	10	68336
3/4"	2"	W208	RZA24U	18,750	10	68337
1"	1-1/2"	W221	RZA24U	19,120	10	68338
1"	2"	W222	RZA24U	15,900	10	68339
5/8"	2"	W197	RZA24U	21,000	10	68366



COATED ABRASIVES

NON-WOVEN ABRASIVES

POWER BRUSHES

NYLON BRUSHES

PACKAGED ITEMS

MAINTENANCE



CASE STUDY:

Learn how Weiler experts increased throughput in a foundry cleaning room.





COATED ABRASIVES

MADE FOR PROFESSIONALS

Weiler manufactures coated abrasive products with grain combinations suited for working on all metals and alloys that will help you get the job done faster. We offer products compatible with both die grinders and angle grinders and – standard and quick change mounting options to fit a wide range of tool sizes and styles.

Technical Information	36-37
Flap Discs	38-43
Resin Fiber Discs	44-47
Blending Discs	48-49
Trim-Kut® Discs	49
Flap Wheels	50-51



Display Packaged and Vending Ready Products Brochure

display pack and vending pack items are indicated throughout this catalog. See our brochure for the full line.

SOLUTIONS SHOWCASE

STEEL PIPING

Problem: A clean bevel end free of any surface imperfections is critical to a strong joint when welding heavy-wall piping. Unfortunately, lengths of steel pipe can sit in yards for significant periods of time, and pitting of the bevel ends is usually the result.

Solution: Coated abrasive flap discs like Weiler's original Tiger Disc are ideal tools for quickly removing heavy corrosion and blending pitting from bevel ends. The chatter-free, compliant grinding action and smooth, consistent finish produced by these discs make them the preferred choice for this application.

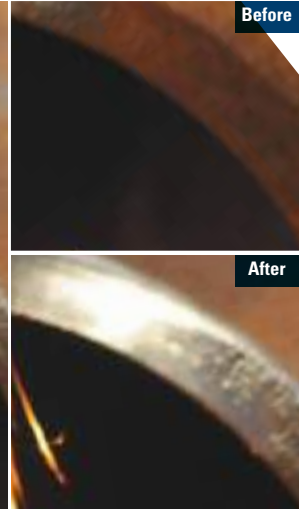

STEEL CHANNEL

Problem: Burrs produced by cut-off operations are dangerous and can prevent parts from fitting together properly, which can cause potential structural weak points.

Solution: Weiler's coated abrasive flap wheels are flexible grinding products that are ideal for light stock removal applications. A 60 grit wheel can be used to remove a large burr and produce a smooth blended edge.



ALUMINUM FRAMES

Problem: Aluminum welds are particularly difficult to blend due to the tendency of the chips to become welded to the abrasive media. This causes the cut rate of the abrasive to fall rapidly and generates an expensive grinding operation.

Solution: Weiler's Tiger® Aluminum discs are specially formulated to prevent loading by lowering the grinding temperature. A 60 grit disc can blend an aluminum weld bead much faster than a conventional disc without loading.

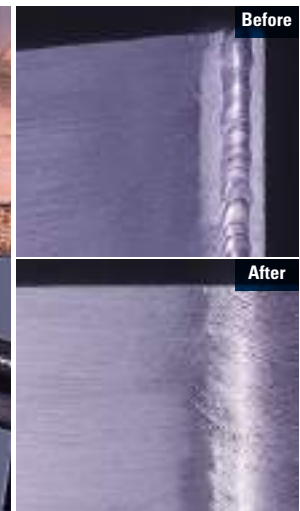



Before



After

STRUCTURAL STEEL BEAM

Problem: Grinding fillet welds is a difficult, time-consuming process that is often expensive to perform.

Solution: Tiger Angled flap discs are a great option for the metalworking professional looking for more versatility than a traditional flap disc can offer and ready to go to work right out of the box. They are ideal for applications that previously required either a carbide burr or trimmable flap disc in order to access welds. Tiger Angled also provides versatility in repair and re-work applications, where it is important to focus grinding in a small area while minimizing impact to the surrounding work piece(s).



Before

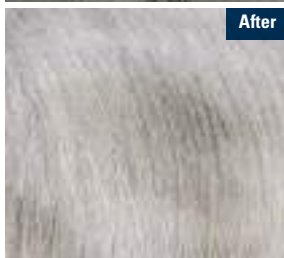

After

TANK AND PRESSURE VESSEL

Problem: The welds inside tanks and pressure vessels must be blended smooth prior to x-ray and pressure testing.

Solution: Weiler's Big Cat® High Density flap discs have the largest flap area in the industry – 22% more cloth. The result is enhanced conformability on curved or irregular surfaces and up to 40% longer life.

SELECTING THE RIGHT FLAP DISC





Weiler's abrasive flap discs grind and finish in one step, saving you time and money. There's no switching from a type 27 grinding wheel to a resin fiber disc.



<p>P MAX PERFORMANCE</p>	 <p>TIGER® 3D MAX</p> <ul style="list-style-type: none"> • TOP COAT for cool grinding • Maximum cut rate • Longer life reduces changeovers 	<p>GRAIN TYPE Ceramic alumina precision-shaped grain</p> <p>CONTAMINANT FREE CONTAIN LESS THAN 0.1% IRON, SULFUR & CHLORINE</p>	<p>STYLES</p> 	<p>BEST ON</p> <p>STEEL / METAL ALUMINUM</p> <p>STAINLESS HARD-TO-GRIND</p> <p>(Hard-to-grind metals include tool steel, inconel, high nickel alloy, titanium and armored steel)</p>
<p>P HIGH PERFORMANCE</p>	 <p>TIGER CERAMIC</p> <ul style="list-style-type: none"> • TOP COAT for cool grinding • Protects from heat discoloration <p>TIGER X</p> <ul style="list-style-type: none"> • FLAT SURFACE GRINDING • Less effort required • Fast grinding & long life 	<p>GRAIN TYPE Ceramic alumina</p> <p>CONTAMINANT FREE CONTAIN LESS THAN 0.1% IRON, SULFUR & CHLORINE</p>	<p>STYLES</p> 	<p>BEST ON</p> <p>STEEL / METAL ALUMINUM</p> <p>STAINLESS HARD-TO-GRIND</p> <p>(Hard-to-grind metals include tool steel, inconel, high nickel alloy, titanium and armored steel)</p>
<p>P PERFORMANCE</p>	 <p>TIGER PAW</p> <ul style="list-style-type: none"> • SUPERIOR EDGE GRINDING • Aggressive stock removal 	<p>GRAIN TYPE Ceramic & zirconia alumina</p> <p>CONTAMINANT FREE CONTAIN LESS THAN 0.1% IRON, SULFUR & CHLORINE</p>	<p>STYLES</p>  <p>*Big Cat</p>	<p>BEST ON</p> <p>STEEL / METAL STAINLESS</p> <p>(Metal includes structural steel and cast iron)</p>
<p>P PERFORMANCE</p>	 <p>TIGER PAW</p> <ul style="list-style-type: none"> • SUPERIOR EDGE GRINDING • Aggressive stock removal 	<p>GRAIN TYPE 100% zirconia alumina</p> <p>CONTAMINANT FREE CONTAIN LESS THAN 0.1% IRON, SULFUR & CHLORINE</p>	<p>STYLES</p> 	<p>BEST ON</p> <p>STEEL / METAL STAINLESS</p> <p>(Metal includes structural steel and cast iron)</p>
<p>V VALUE</p>	 <p>WOLVERINE®</p> <ul style="list-style-type: none"> • Fast stock removal • Consistent performance 	<p>GRAIN TYPE Zirconia alumina</p>	<p>STYLES</p> 	<p>BEST ON</p> <p>STEEL / METAL</p>

*Big Cat is a zirconia alumina flap disc and does not contain any ceramic alumina.

SPECIALTY FLAP DISCS

		HIGH PERFORMANCE	PERFORMANCE
ANGLED (Fillet Welds)		<input checked="" type="checkbox"/>	
TRIMMABLE (Non-Marking)		<input checked="" type="checkbox"/>	
ALUMINUM BACK (Rigid Support)		<input checked="" type="checkbox"/>	
ALUMINUM (Non-Loading)		<input checked="" type="checkbox"/>	
MINI (Tight Spaces)			<input checked="" type="checkbox"/> (Bobcat)

STYLE



CONICAL (Type 29)
15° – 35°



Angled flaps maximize surface contact for aggressive stock removal on flat surfaces.



FLAT (Type 27)
0° – 15°



Smooth grinding, blending and finishing on flat surfaces and slight contours.



HIGH DENSITY (Type 27)
0° – 15°



Conformable to irregular surfaces. Smooth grinding, blending and finishing on flat surfaces.



HIGH DENSITY (Type 29)
15° – 35°



Conformable to irregular surfaces. Angled flaps maximize surface contact for aggressive stock removal.



ANGLED (Type 27 / Hybrid)
0° – 35°



Curved flaps for grinding fillet welds, T-joints and hard-to-reach areas.

GRIT

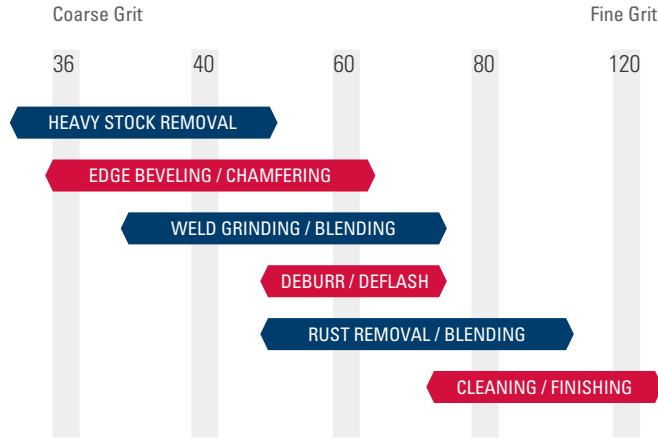

GRAIN



3D MAX PRECISION-SHAPED CERAMIC

- Self-sharpening micro fracturing crystals expose sharp edges
- Maximum cut rate for the life of the grain



CERAMIC ALUMINA (CA)

- Maintains a high cut rate for the life of the grain
- Long cutting life under moderate to high pressure



ZIRCONIA ALUMINA (ZA)

- Holds up under high temperatures and extreme pressure
- Sharp, fast cutting, long lasting grain



ALUMINUM OXIDE (AO)

- Single crystal that dulls during use
- Good initial cut rate

BACKING

PHENOLIC



Prevents backing from scratching the workpiece.

ALUMINUM



Rigid support for maximum aggression; recyclable.

COMPOSITE*



Trimable, non-marking backing; allows access to hard-to-reach areas.

*BobCat™ Discs are not Trimmable.

ARBOR

5/8" - 11 NUT

- Quick change over
- Eliminates cross-threading experienced with plastic backs
- Metal nut eliminates the disc from sticking to the grinder due to heat build up



OPEN ARBOR

- Requires adapting nuts
- 5/8" option for 4" grinders
- 7/8" option for 4-1/2" and larger grinders



MOUNTING DISCS WITH OPEN ARBORS



MANDRELS & METAL HUB PADS

- For quick-change on tools with 1/4" collets



WHY WEILER BONDED ABRASIVES COATED ABRASIVES NON-WOVEN ABRASIVES POWER BRUSHES NYLON BRUSHES PACKAGED ITEMS MAINTENANCE

STANDARD DENSITY FLAP DISCS



Weiler offers standard density flap discs in four performance tiers, including our new Tiger® 3D MAX with precision-shaped grain. These discs combine exceptional material removal with flexibility and control, enabling operators to grind faster while maintaining finish quality across a wide range of applications.



Tiger 3D MAX flap disc beveling a stainless steel tube.

MORE FOR YOUR MONEY

3D MAX grinds up to 30% faster than standard ceramic, so welders have more time to focus on what they do best. **



3D MAX Precision-Shaped Grain



Standard Ceramic Grain

**30%
FASTER**

NEW

P MAX PERFORMANCE / TIGER® 3D MAX

Top Coated for Cool Grinding / Ceramic Precision-Shaped Grain / Phenolic Back / Contaminant-free*

STEEL / METAL	STAINLESS	HARD-TO-GRIND	ALUMINUM	TYPE 29	
				7/8" Arbor	5/8"-11 Hub
Diameter	Grit	Max. RPM	Std. Pack	Item #	Item #
4-1/2"	40+	13,000	10	50160	50164♦
	60+			50162	50165♦
	80+			50163	50166♦
7"	40+	8,600	10	50183 •	50186♦ •
	60+			50184 •	50187♦ •
	80+			50185 •	50188♦ •

* Non-stock product, contact Customer Service for lead times and minimum order quantities.



50160

P HIGH PERFORMANCE / TIGER® CERAMIC (SABER TOOTH)

Top Coated for Cool Grinding / Ceramic Alumina / Phenolic Back / Contaminant-free*

STEEL / METAL	STAINLESS	HARD-TO-GRIND	ALUMINUM	TYPE 29	
				7/8" Arbor	5/8"-11 Hub
Diameter	Grit	Max. RPM	Std. Pack	Item #	Item #
4-1/2"	36	13,000	10	50100	50104♦
	40			50101	50105♦ V
	60			50102	50106♦
	80			50103	50107♦
	80			50103	50107♦
7"	36	8,600	10	—	50112♦
	40			50109	50113♦

P V Display Packed & Vending Ready product available, add P or V to the end of item number when placing order.



50106

P HIGH PERFORMANCE / TIGER X

Fast Grinding & Long Life on Flat Surfaces / Ceramic & Zirconia Alumina / Phenolic Back / Contaminant-free*

STEEL / METAL	STAINLESS	Max. RPM	Std. Pack	TYPE 29		TYPE 27	
				7/8" Arbor	5/8"-11 Hub	7/8" Arbor	5/8"-11 Hub
Diameter	Grit	Max. RPM	Std. Pack	Item #	Item #	Item #	Item #
4-1/2"	36	13,000	10	51200	51204♦	—	—
	40			51201	51205♦	51223	51226♦
	60			51202	51206♦	51224	51227♦
	80			51203	51207♦	51225	51228♦
	80			51203	51207♦	51225	51228♦
5"	36	12,000	10	—	—	—	—
	40			51208	51212♦	—	—
	60			51209	51213♦	—	—
	80			51210	51214♦	—	—
6"	40	10,200	10	51237	51241♦	—	—
	60			51238	51242♦	—	—
7"	36	8,600	10	51215	51219♦	—	—
	40			51216	51220♦	51229	51232♦
	60			51217	51221♦	—	51233♦
	80			—	51222♦	51231	51234♦



51205

♦ Patent # 6,945,863

*Contaminant-free (Contains less than 0.1% Fe, S, Cl)

** Test results are based on manual grinding of carbon steel, comparing the material removal rate of 3D MAX discs to standard ceramic discs.

P PERFORMANCE / ORIGINAL TIGER

High cut rate & long life / Zirconia Alumina / Phenolic Back / Contaminant-free*

STEEL / METAL		STAINLESS		TYPE 29 5/8" Arbor	TYPE 29 7/8" Arbor	TYPE 29 5/8"-11 Hub	TYPE 27 5/8" Arbor	TYPE 27 7/8" Arbor	TYPE 27 5/8"-11 Hub
Dia.	Grit	Max. RPM	Std. Pack	Item #	Item #	Item #	Item #	Item #	Item #
4"	36	15,000	10	50592 •	—	—	—	—	—
	40			50593	—	—	50694	—	—
	60			50594	—	—	—	—	—
	80			50595	—	—	—	—	—
4-1/2"	24	13,000	10	—	50601	—	—	—	—
	120			50606	—	—	—	50706	50699♦
5"	40	12,000	10	—	—	—	—	50713 •	—
	60			—	—	—	—	50714 •	—
	80			—	—	—	—	50715	—
6"	40	10,200	10	—	50649	50659♦	—	—	—
	60			50650	50660♦	—	—	—	—
	80			50651	50661♦	—	—	—	—



50601

P PERFORMANCE / TIGER PAW™

Aggressive Stock Removal for Edge Grinding / 100% Zirconia Alumina / Phenolic Back / Contaminant-free*

STEEL / METAL		STAINLESS		TYPE 29 5/8" Arbor	TYPE 29 7/8" Arbor	TYPE 29 5/8"-11 Hub	TYPE 27 5/8" Arbor	TYPE 27 7/8" Arbor	TYPE 27 5/8"-11 Hub
Dia.	Grit	Max. RPM	Std. Pack	Item #	Item #	Item #	Item #	Item #	Item #
4"	40	15,000	10	51104	—	—	51101	—	—
	60			51105	—	—	51102	—	—
4-1/2"	36	13,000	10	—	51118	51123♦	—	51107	51112♦
	40			—	51119	51124♦	—	51108	51113♦
	60			—	51120 ▼	51125 ▼	—	51109	51114♦
	80			—	51121	51126♦	—	51110	51115♦
5"	36	12,000	10	—	—	51153♦	—	—	51155♦
	40			—	51129	51132♦	—	51134	51156♦
	60			—	—	51133♦	—	51135	51157♦
	80			—	—	51154♦	—	—	51158♦
6"	40	10,200	10	—	51175	51179♦	—	—	—
	60			—	51176	51180♦	—	—	—
	80			—	51177 •	51181 •	—	—	—
7"	36	8,600	10	—	—	51149♦	—	—	51139♦
	40			—	51145	51146♦	—	51137	51140♦
	60			—	51150	51147♦	—	—	51142♦
	80			—	—	51148♦	—	—	51143♦



51126

▼ Display Packed & Vending Ready product available, add P or V to the end of item number when placing order.

V WOLVERINE®

Consistent Performance / Zirconia Alumina / Phenolic Back

STEEL / METAL		STAINLESS		TYPE 29 5/8" Arbor	TYPE 29 7/8" Arbor	TYPE 29 5/8"-11 Hub	TYPE 27 7/8" Arbor	TYPE 27 5/8"-11 Hub
Dia.	Grit	Max. RPM	Std. Pack	Item #	Item #	Item #	Item #	Item #
4"	36	15,000	10	31337	—	—	—	—
	40			31338	—	—	—	—
	60			31339	—	—	—	—
4-1/2"	36	13,000	10	—	31343	31349♦	31401	31407♦
	40			—	31344	31350♦	31402	31408♦
	60			—	31345	31351♦	31403	31409♦
	80			—	31346	31352♦	31404	31410♦
	120			—	31347 •	31353♦	—	—
5"	36	12,000	10	—	31355	—	—	—
	40			—	31356	—	—	—
	60			—	31357	—	—	—
	80			—	31358	—	—	—
6"	60	10,200	10	—	—	31452♦	—	—
	80			—	—	31453♦	—	—
7"	36	8,600	10	—	31361	31367♦	—	31419♦
	40			—	31362	31368♦	—	31420♦
	60			—	31363	31369♦	31415	31421♦
	80			—	31364 •	31370♦	—	31422♦



31338

31343

Key:

P PERFORMANCE LINE Industrial Grade

V VALUE LINE Professional Grade

• Non-stock product, contact Customer Service for lead times and minimum order quantities.

♦ Patent # 6,945,863

*Contaminant-free (Contains less than 0.1% Fe, S, Cl)

WHY WEILER BONDED ABRASIVES

COATED ABRASIVES

NON-WOVEN ABRASIVES

POWER BRUSHES

NYLON BRUSHES

PACKAGED ITEMS

MAINTENANCE

HIGH DENSITY FLAP DISCS



Blending and finishing a weld with a Big Cat flap disc.

High density discs have more flaps than standard density discs, giving them a thicker profile that increases flexibility and allows the disc to conform to curves and irregular surfaces more easily. The high-density design also reduces vibration, improving operator experience. These discs last up to 40% longer than a standard density disc.



INDUSTRY-LEADING FOOTPRINT

30MM WIDE FLAPS **25MM WIDE FLAPS**
BIG CAT & TIGER PAW HD INDUSTRY STANDARD



50134

P HIGH PERFORMANCE / TIGER® CERAMIC HD (SABER TOOTH)

Top Coated for Cool Grinding on Irregular Surfaces / Ceramic Alumina / Phenolic Back / Contaminant-free*

STEEL / METAL STAINLESS HARD-TO-GRIND ALUMINUM

Diameter	Grit	Max. RPM	Std. Pack	TYPE 27	
				7/8" Arbor	5/8"-11 Hub
				Item #	Item #
4-1/2"	40	12,000	10	50130	50133♦
	60			50131	50134♦
	80			50132	50135♦
7"	40	8,600	10	50136	50139♦
	60			—	50140♦
	80			—	50141♦



50804

P HIGH PERFORMANCE / TIGER BIG CAT® HD

Fast Grinding & Long Life on Irregular Surfaces / Zirconia Alumina / Phenolic Back / Contaminant-free*

STEEL / METAL STAINLESS

Diameter	Grit	Max. RPM	Std. Pack	TYPE 27	
				7/8" Arbor	5/8"-11 Hub
				Item #	Item #
4-1/2"	40	12,000	10	50803 V	50808♦
	60			50804 V	50809♦ V
	80			50805	50810♦
	120			50806	—
	7"			40	8,600
60	50824	50844♦			
80	50825	50845♦			

V **V** Display Packed & Vending Ready product available, add P or V to the end of item number when placing order.



51165

P PERFORMANCE / TIGER PAW™ HD

Aggressive Stock Removal on Irregular Surfaces / 100% Zirconia Alumina / Phenolic Back / Contaminant-free*

STEEL / METAL STAINLESS

Diameter	Grit	Max. RPM	Std. Pack	TYPE 29		TYPE 27	
				7/8" Arbor	5/8"-11 Hub	7/8" Arbor	5/8"-11 Hub
				Item #	Item #	Item #	Item #
4-1/2"	36	12,000	10	51060	51064♦•	51160	51164♦
	40			51061	51065♦	51161	51165♦
	60			51062	51066♦•	51162	51166♦
	80			51063•	51067♦•	51163	51167♦
	6"			40	10,200	10	—
60	—	—	51192	—			
7"	40	8,600	10	—	—	51170	51168♦
	60			—	—	—	51169♦



31388

V WOLVERINE® HD

Consistent Performance on Irregular Surfaces / Zirconia Alumina / Phenolic Back

STEEL / METAL

Diameter	Grit	Max. RPM	Std. Pack	TYPE 27	
				7/8" Arbor	5/8"-11 Hub
				Item #	Item #
4-1/2"	40	12,000	10	31387	31390♦
	60			31388	31391♦
	80			31389	31392♦
6"	40	10,200	10	31439•	—

• Non-stock product, contact Customer Service for lead times and minimum order quantities.

♦ Patent # 6,945,863

*Contaminant-free (Contains less than 0.1% Fe, S, Cl)

SPECIALTY FLAP DISCS

ALUMINUM BACK

Tiger Aluminum Back flap discs are the benchmark for the pipeline industry, providing rigid support for maximum aggression. These discs are ideal for removing heavy pitting and resists rolling the bevel ends prior to welding. The aluminum backing also prevents the disc from catching on the bevel when grinding. The aluminum backing plate is 100% recyclable.



Edge chamfering a section of pipe with a Tiger Aluminum Back flap disc.

P HIGH PERFORMANCE / TIGER® ALUMINUM BACK

Fast Grinding & Long Life / Zirconia Alumina / Backing Plate Provides Rigid Support / Contaminant-free*

Diameter	Grit	Max. RPM	Std. Pack	TYPE 29	TYPE 29	TYPE 29
				5/8" Arbor	7/8" Arbor	5/8"-11 Hub
				Item #	Item #	Item #
4"	36	15,000	10	50502	—	—
	40			50503	—	—
	60			50504	—	—
	80			50505	—	—
4-1/2"	24	13,000	10	—	50511	50510
	36			—	50512	50517
	40			—	50513	50518
	60			—	50514	50519
	80			—	50515	50520
	120			—	50516	50509
7"	24	8,600	10	—	—	50541
	36			—	—	50542
	40			—	—	50543
	60			—	—	50544
	80			—	—	50545



FOR ALUMINUM

Tiger Aluminum flap discs offer an innovative paired flap design that delivers high performance grinding on aluminum. The top flaps are coated to eliminate loading and allow the disc to maintain a high cut rate, while the alternating flaps aggressively remove material with self-sharpening zirconia aluminum grains. This unique paired flap design delivers the ultimate combination of high performance grinding for aluminum at an exceptional value.



P HIGH PERFORMANCE / TIGER® ALUMINUM

Non-Loading / Contaminant-free* / Zirconia Alumina / Phenolic Back

Diameter	Grit	Max. RPM	Std. Pack	TYPE 27	TYPE 27	TYPE 29	TYPE 29
				7/8" Arbor	5/8"-11 Hub	7/8" Arbor	5/8"-11 Hub
				Item #	Item #	Item #	Item #
4-1/2"	36	13,000	10	51252	51256	51250	51254
	60			51253	51257	51251	51255



Key:

P PERFORMANCE LINE
Industrial Grade

V VALUE LINE
Professional Grade

◆ Patent # 6,945,863

*Contaminant-free (Contains less than 0.1% Fe, S, Cl)

ANGLED DISCS

Weiler's Tiger Angled flap discs offer a curved flap design that is ideal for grinding fillet welds, T-joints and hard-to-reach places. The flaps wrap around the edge of the backing plate, optimizing metal contact and providing exceptional feel and control.



Angled flaps are ideal for fillet welds and hard-to-reach places



51313

P HIGH PERFORMANCE / TIGER® CERAMIC ANGLED

Top Coated for Cool Grinding on Fillet Welds / Ceramic Alumina / Phenolic Back / Contaminant-free*

STEEL / METAL		STAINLESS		HARD-TO-GRIND		ALUMINUM		7/8" Arbor		5/8"-11 Hub	
Diameter	Grit	Max. RPM	Std. Pack	Item #	Item #	Item #	Item #	Item #	Item #	Item #	Item #
4-1/2"	40	13,000	10	51312	51315	51313	51316	51314	51317		
	60			51318	51321						
	80			51319	51322						
5"	40	12,000	10								
	60										



51303

P HIGH PERFORMANCE / TIGER ANGLED

Fast Grinding & Long Life on Fillet Welds / Zirconia Alumina / Phenolic Back / Contaminant-free*

STEEL / METAL		STAINLESS		HARD-TO-GRIND		ALUMINUM		7/8" Arbor		5/8"-11 Hub		
Diameter	Grit	Max. RPM	Std. Pack	Item #	Item #	Item #	Item #	Item #	Item #	Item #	Item #	
4-1/2"	40	13,000	10	51300	51303	51301	51304					
	60											
	80											
5"	40	12,000	10	51306	51309							

TRIMMABLE DISCS

A trimmable backing plate allows the operator to increase flap overhang. This feature provides the versatility to adjust for hard-to-reach areas such as fillet welds and irregular shapes.

- Composite backing that can be trimmed, exposing more abrasive material.
- Composite backing will not mark the workpiece.



50121

P HIGH PERFORMANCE / TIGER CERAMIC TRIM (SABER TOOTH)

Top Coated for Cool Grinding / Ceramic Alumina / Trimmable Composite Back for Versatility / Contaminant-free*

STEEL / METAL		STAINLESS		HARD-TO-GRIND		ALUMINUM		TYPE 29 7/8" Arbor		TYPE 29 5/8"-11 Hub	
Diameter	Grit	Max. RPM	Std. Pack	Item #	Item #	Item #	Item #	Item #	Item #	Item #	Item #
4-1/2"	40	13,000	10	50117	50121♦						
	60			50118	50122♦						



50003

P PERFORMANCE / TIGER TRIM

Long Grinding Life / Zirconia Alumina / Trimmable Composite Back for Versatility / Contaminant-free*

STEEL / METAL		STAINLESS		HARD-TO-GRIND		ALUMINUM		TYPE 29 7/8" Arbor		TYPE 29 5/8"-11 Hub	
Diameter	Grit	Max. RPM	Std. Pack	Item #	Item #	Item #	Item #	Item #	Item #	Item #	Item #
4-1/2"	40	13,000	10	50002	50006♦						
	60			50003	50007♦						
	80			50004	50008♦						
	120			—	50009♦						
	—										
5"	40	12,000	10	50010	—						

Key:

P PERFORMANCE LINE Industrial Grade **V** VALUE LINE Professional Grade

♦ Patent # 6,945,863

*Contaminant-free (Contains less than 0.1% Fe, S, Cl)

MINI DISCS

Tiger Bobcat mini flap discs are ideal for use on air die grinders for smooth grinding and enhanced conformability in tight areas when working with steel and stainless steel. These mini discs leverage self-sharpening zirconia alumina (ZA) grains that hold up under high temperatures and extreme pressure.

Bobcat sheds cloth and exposes new grain, delivering a consistent, aggressive cut rate and removing 3 times more material over the life of the disc than a comparable blending disc.

Weiler BobCat mini flap discs are designed and compatible for use on both industry standard hub pads.



S Mount



R Mount



Removing paint in tight spaces is easy with a BobCat disc.

PERFORMANCE / TIGER BOBCAT™

Grinding Hard-to-Reach Places / Zirconia Alumina / Composite Back / Contaminant-free*

STEEL / METAL		STAINLESS		S MOUNT* TYPE 29		S MOUNT* TYPE 27		R MOUNT+ TYPE 29		R MOUNT+ TYPE 27	
Diameter	Grit	Max. RPM	Std. Pack	Item #	Item #	Item #	Item #	Item #	Item #	Item #	Item #
2"	36	30,000	10	—	50932	50946	50956	—	50932	50946	50956
	40			50923	50933	50947	50957	—	50933	50947	50957
	60			50924	50934	50948	50958	—	50934	50948	50958
	80			50925	50935	50949	50959	—	50935	50949	50959
	120			—	50936	50950	50960	—	50936	50950	50960
3"	36	20,000	10	50902	50912	50951	50961	—	50902	50912	50961
	40			50903	50913	50952	50962	—	50903	50913	50962
	60			50904	50914	50953	50963	—	50904	50914	50963
	80			50905	50915	50954	50964	—	50905	50915	50964
	120			—	50916	—	50965	—	—	50916	—

* Back-up pad not required if used with S mount mandrel. 3" discs are compatible with Norton Speed-Lok® TS back-up pads.

+ Back-up pad required. Also compatible with 3M Roloc™ back-up pads.



ACCESSORIES

BOBCAT DRIVE MANDRELS & METAL HUB PADS

For quick-change on tools with 1/4" collets.

Description	Std. Pack	Item #
2" & 3" S mount mandrel	1	07766 •
3" S mount hub pad + mandrel	1	60509
3" R mount hub pad + mandrel	1	51552



56495

ADAPTING NUTS & SPANNER WRENCH

For use with standard, HD and specialty flap discs.

Description	Thread Size	For Use With	Std. Pack	Item #
Adapting Nuts	3/8" - 24	4" flap disc with 5/8" arbor hole (can be used with an adjustable or combination wrench)	1 Pair	56484
Adapting Nuts	5/8" - 11	4-1/2", 5" & 7" flap discs with 7/8" arbor hole	1 Pair	56494
Spanner Wrench	—	Item No. 56494 only	1	56495

When mounting, adapters must be nested, see illustration at left.

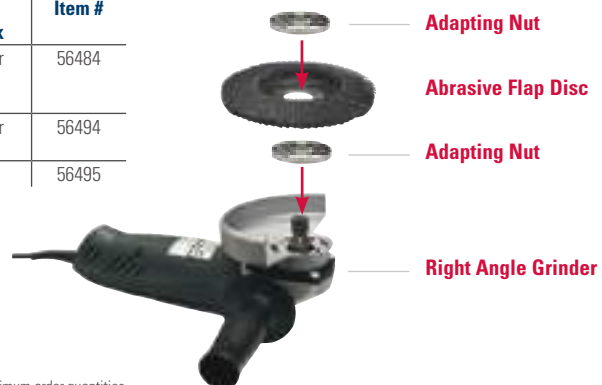

Adapting Nut

Abrasive Flap Disc

Adapting Nut

Right Angle Grinder

• Non-stock product, contact Customer Service for lead times and minimum order quantities.

COATED ABRASIVES

NON-WOVEN ABRASIVES

POWER BRUSHES

NYLON BRUSHES

PACKAGED ITEMS

MAINTENANCE

RESIN FIBER DISCS



Smoothing the edges of rollercoaster track with a resin fiber disc.

Faced with the challenge of working on everything from pressure vessels to roller coasters, professionals need a solution they can count on. That's why we've expanded our offering to deliver the options needed to optimize grinding time on a wide variety of applications. With premium grain mixes that aggressively remove metal and a superior design that locks the grain in, Weiler Tiger and Wolverine resin fiber discs are designed to deliver serious grinding solutions.

- Advanced grain formulas designed to maximize cut rate on metals
- Superior design minimizes loading, glazing and grain stripping
- Heavy-duty vulcanized fiber backing holds up to the toughest jobs
- Quick change hub option reduces down time and eliminates interference from adapter rings
- Spiral molded backing pad design runs cool by increasing airflow and fits on all right angle grinders

SELECTING THE RIGHT DISC

P MAX PERFORMANCE SUPERIOR CUT & LIFE



TIGER® 3D MAX TOP COAT for cool, fast grinding protects from heat discoloration

GRAIN TYPE
3D percision-shaped ceramic alumina
CONTAMINANT FREE*

BEST ON

STAINLESS **HARD-TO-GRIND**

(Hard-to-grind metals include tool steel, inconel, high nickel alloy, titanium and armored steel)

TIGER 3D MAX UNCOATED discs provide maximum cut rate

GRAIN TYPE
3D percision-shaped ceramic alumina
CONTAMINANT FREE*

BEST ON

STEEL / METAL

P HIGH PERFORMANCE FAST CUT & LONG LIFE



TIGER CERAMIC TOP COAT for cool, fast grinding protects from heat discoloration

GRAIN TYPE
Ceramic alumina
CONTAMINANT FREE*

BEST ON

STEEL / METAL **STAINLESS** **HARD-TO-GRIND**

(Hard-to-grind metals include tool steel, inconel, high nickel alloy, titanium and armored steel)

TIGER ALUMINUM TOP COAT grinds cool and eliminates loading

GRAIN TYPE
Aluminum oxide
CONTAMINANT FREE*

BEST ON

ALUMINUM

(Aluminum and other non-ferrous metals)

TIGER ZIRC INFUSED WITH CERAMIC for faster grinding and longer life

GRAIN TYPE
Ceramic & zirconia alumina
CONTAMINANT FREE*

BEST ON

STEEL / METAL **STAINLESS**

(Metal includes structural steel and cast iron)

V VALUE PERFORMANCE FAST CUT



WOLVERINE® ZIRC FAST CUT RATE and consistent performance over the life of the disc, resulting in a great value

GRAIN TYPE
Zirconia alumina
CONTAMINANT FREE*

BEST ON

STEEL / METAL **STAINLESS**

(Metal includes structural steel and cast iron)

WOLVERINE AO PREMIUM GRAINS provide an even, sharp, clean cut rate and consistent performance at a great value

GRAIN TYPE
White aluminum oxide

BEST ON

STEEL / METAL

*Contaminant-free (Contains less than 0.1% Fe, S, Cl)



Tiger 3D MAX ceramic resin fiber discs are built for maximum performance on the toughest metals. Featuring 3D precision-shaped grain, they deliver exceptional cut rate, durability, and cool grinding for maximum productivity. Designed to boost throughput and reduce operator fatigue, these discs help finish your work faster.

- 3D precision-shaped grain provides **maximum cut rate** and material removal
- Grain stands upright to **slice through metal effortlessly**
- Optimized grain retention keeps the disc grinding longer and **reduces changeovers**
- Contaminant-free formula **provides peace of mind**
- Micro-fracturing technology and 3D shape **make the work easier**



Tiger 3D MAX top coated disc edge grinding a stainless steel bracket.

NEW

P TIGER 3D MAX CERAMIC / TOP COAT

Superior Grinding & Life / Ceramic Alumina / Contaminant-free*
A top coated disc grinds cooler and protects parts from heat damage and discoloration.

STAINLESS		HARD-TO-GRIND		7/8" Arbor		5/8"-11 Hub	
Diameter	Grit Size	Standard Pack	Item #	Item #	Item #	Item #	Item #
4-1/2"	36+	25	68703	68735			
	60+		68704	-			
	80+		68705	-			
5"	36+	25	68709	68741			
	60+		68710	-			
	80+		68726	68754			
7"	36+	25	68727	-			
	60+						



68703

NEW

P TIGER 3D MAX CERAMIC / UNCOATED

Superior Grinding & Life / Ceramic Alumina / Contaminant-free*

STEEL / METAL		7/8" Arbor		5/8"-11 Hub	
Diameter	Grit Size	Standard Pack	Item #	Item #	Item #
4-1/2"	36+	25	68700	68730	
	60+		68701	68731	
	80+		68702	-	
5"	36+	25	68706	68738	
	60+		68707	68739	
	80+		68708	-	
7"	36+	25	68723	68750	
	60+		68724	-	
	80+		68725	-	

*Contaminant-free (Contains less than 0.1% Fe, S, Cl)



68700

LASTS LONGER, GRINDS MORE

Grain only works when it's on the disc. 3D MAX holds onto the grain longer, removing more material over the life of the disc.



Test results based on manual grinding of carbon steel. Weiler Tiger 3D MAX removed 32% more material by weight over the life of the disc compared to the competitor ceramic shaped grain.

BOUNDED ABRASIVES

COATED ABRASIVES

NON-WOVEN ABRASIVES

POWER BRUSHES

NYLOX BRUSHES

PACKAGED ITEMS

MAINT.

69867



P **TIGER® CERAMIC RESIN FIBER DISCS** Ceramic Alumina / Fast Grinding & Long Life on Metal
Self-sharpening Ceramic Alumina grain delivers fast stock removal with a finer scratch pattern.
Top coat grinds cool and eliminates loading.

STEEL / METAL **STAINLESS** **ALUMINUM** **HARD-TO-GRIND**

Diameter	Grit Size	Standard Pack	7/8" Arbor		5/8"-11 Hub	
			Item #	Item #	Item #	Item #
4-1/2"	24	25	69850	69880		
	36		69851	69881		
	50		69852	—		
	60		69853	69883		
	80		69854	—		
5"	24	25	69857	69887		
	36		69858	69888		
	50		69859	—		
	60		69860	69890		
7"	24	25	69864	69894		
	36		69865	69895		
	50		69866	—		
	60		69867	—		
	80		69868	69898		
9"	24	25	69871	—		

Do not exceed maximum RPM of back-up pad.

69883

P **TIGER ALUMINUM RESIN FIBER DISCS** Aluminum Oxide / Non-Loading on Non-Ferrous Metals
A top coating grinds cool and eliminates loading, which results in higher cut rates, long life and a superior finish.

ALUMINUM

Diameter	Grit Size	Standard Pack	7/8" Arbor		5/8"-11 Hub	
			Item #	Item #	Item #	Item #
4-1/2"	36	25	60401	60601		
	60		60403	60603		
	80		60404 •	—		
5"	24	25	60410	—		
	36		60411	60611 •		
	80		60414	—		
7"	36	25	60421	—		
	60		60423	—		

Do not exceed maximum RPM of back-up pad.

60603

P **TIGER® ZIRC RESIN FIBER DISCS** Zirconia Alumina / Ceramic Infused for Faster, Longer Grinding
A unique blend of self-sharpening Zirconia Alumina and Ceramic Alumina grains deliver a fast, consistent cut rate.
A superior design extends disc life by minimizing grain shedding and promotes cool grinding.

STEEL / METAL **STAINLESS**

Diameter	Grit Size	Standard Pack	7/8" Arbor		5/8"-11 Hub	
			Item #	Item #	Item #	Item #
4-1/2"	24	25	59731	59931 •		
	36		59732	59932		
	50		59733 •	—		
	60		59734	—		
	80		59735	—		
	120		59737 •	—		
5"	24	25	59701	—		
	36		59702	—		
	50		59703	—		
	60		59704	—		
	80		59705	—		
	120		59707 •	—		
7"	24	25	59711	—		
	36		59712	—		
	50		59713	—		
	60		59714	—		

Do not exceed maximum RPM of back-up pad.

59702

• Non-stock product, contact Customer Service for lead times and minimum order quantities.



V WOLVERINE® ZIRC RESIN FIBER DISCS Zirconia Alumina / Fast Grinding on Metal

Self-sharpening Zirconia Alumina grain delivers a fast cut rate and consistent performance over the life of the disc, resulting in a great value.

STEEL / METAL **STAINLESS**

Diameter	Grit Size	Standard Pack	7/8" Arbor	5/8"-11 Hub
			Item #	Item #
4-1/2"	24	25	62002	—
	36		62003	62053 •
	50		62004 •	—
5"	24	25	62012	—
	36		62013	—
	50		62014 •	—
	60		62015 •	—

Do not exceed maximum RPM of back-up pad.



WHY WEILER
BONDED ABRASIVES

COATED ABRASIVES

V WOLVERINE® AO RESIN FIBER DISCS White Aluminum Oxide / Fast Grinding on Metal

Premium Aluminum Oxide grains provide an even, sharp, clean cut rate and consistent performance at a great value.

STEEL / METAL

Diameter	Grit Size	Standard Pack	5/8" Arbor	
			Item #	
4"	24	25	59491	
	36		59492	
	50		59493	
	60		59494	
	80		59495	
	120		59497 •	
Diameter	Grit Size	Standard Pack	7/8" Arbor	5/8"-11 Hub
			Item #	Item #
4-1/2"	24	25	59571	—
	36		59573	—
	50		59575	—
	60		59576	—
	80		59577	—
	120		59579 •	—
5"	24	25	59501	—
	36		59503	61503
	50		59505	—
	60		59506	—
	80		59507	—
7"	16	25	59520	—
	24		59521	—
	36		59523	—
	60		59526 •	—
	80		59527 •	—
	100		59528 •	—
9"	24	25	59541 •	—
	80		59547	—

Do not exceed maximum RPM of back-up pad.



NON-WOVEN ABRASIVES

POWER BRUSHES

NYLON BRUSHES

PACKAGED ITEMS

MAINTENANCE

ACCESSORIES FOR RESIN FIBER DISCS

Description	Thread Size	Max. RPM	Standard Pack	Item #
4" Back-up Pad	5/8"-11*	12,000	1	59605
4-1/2" Back-up Pad	5/8"-11*	11,000	1	59611
5" Back-up Pad	5/8"-11*	10,000	1	59600
7" Back-up Pad	5/8"-11	8,500	1	59601
9" Back-up Pad	5/8"-11	6,500	1	59602 •
Spanner Wrench	—	—	1	59603 •
Disc Nut	5/8"-11	—	1	59604

* Other thread sizes available on special orders.



• Non-stock product, contact Customer Service for lead times and minimum order quantities.

BLENDING DISCS



Blending disc smoothing weld seams.

These improved quick-change discs deliver faster material removal and longer product life. Available in ceramic, zirconia alumina, and aluminum oxide grain options, they provide the performance needed for increased productivity when grinding and blending in hard-to-reach areas.

TYPE R



RESIN FIBER BACK

Provides an aggressive cut rate without applying additional pressure

TYPE S



CLOTH BACK

Conforms to the workpiece, giving the operator greater control of the material being removed



NEW

P TIGER 3D MAX CERAMIC Precision-Shaped Grain / Top Coat / Superior Cut & Life / Contaminant-free*

STEEL / METAL STAINLESS HARD-TO-GRIND ALUMINUM



60955

Diameter	Grit Size	Standard Pack	Resin Fiber Backing	
			Type R Item #	Type S Item #
2"	36+	50	60855	60850
	60+		60875	-
3"	36+	25	60955	60870
	60+		60975	-

P CERAMIC ALUMINA Top Coat / Fast Cut & Life / Contaminant-free*

STEEL / METAL STAINLESS HARD-TO-GRIND ALUMINUM



60575

Diameter	Grit Size	Standard Pack	Resin Fiber Backing		Cloth Backing	
			Type R Item #	Type S Item #	Type R Item #	Type S Item #
2"	36	50	60570 •	60550	60170	60150
	60		60571	60551	60171	-
	80		60572	-	60172	60152
3"	36	25	60575	60555 •	60175	60155
	60		60576	60556	60176	60156 •
	80		60577	-	-	-

Ceramic Type R Resin Fiber Backing Color Coding: ○ 36 Grit - White ● 60 Grit - Orange ● 80 Grit - Yellow

P ZIRCONIA ALUMINA Fast Cut & Life / Contaminant-free*

STEEL / METAL Including structural steel and cast iron.



60391

Diameter	Grit Size	Standard Pack	Resin Fiber Backing		Cloth Backing	
			Type R Item #	Type S Item #	Type R Item #	Type S Item #
2"	36	100	60338	-	60738	60778
	60		60341 •	-	60741 •	60781 •
	80		60342	60382	60742 •	60782 •
	120		60344 •	60384	60744 •	60784 •
3"	36	50	60351	60391	60751	60791
	60		60354	-	60754 •	60794 •
	80		60355	-	60755 •	60795 •
	120		60357 •	-	60757 •	60797 •

P ALUMINUM OXIDE Fast Cut

STEEL / METAL and other materials, including fiberglass, plastic, and wood.



60131

Diameter	Grit Size	Standard Pack	Resin Fiber Backing		Cloth Backing	
			Type R Item #	Type S Item #	Type R Item #	Type S Item #
2"	36	100	60660	60640	60118	60040
	60		60663	60643	60121	60043
	80		60664	60644	60122	-
	120		60666 •	60646	60124	-
3"	36	50	60670	60650	60131	-
	60		60673	60653	60134	-
	80		60674	60654 •	60135	60057
	120		60676 •	60656 •	60137	60059

*Contaminant-free (Contains less than 0.1% Fe, S, Cl)

• Non-stock product, contact Customer Service for lead times and minimum order quantities.

P TIGER ALUMINUM BLENDING DISCS Fast Cut & Life / Top Coat / Aluminum Oxide

Diameter	Grit Size	Standard Pack	Resin Fiber Backing	
			Type R Item #	Type S Item #
2"	36	50	59806	59869
	60		59807	—
	80		—	59871 •
3"	36	25	59811	—
	60		59812	59875
	80		59813	59876



BLENDING DISC BACK-UP PADS - 1/4" Stem

Diameter	Max. RPM	Standard Pack	Type R Item # *	Type S Item # +
2"	25,000	1	51551	60508
3"	20,000	1	51552	60509



Do not exceed maximum RPM of back-up pad.
 * Compatible with 3M Roloc™ back-up pads. (Roloc™ is a trademark of 3M.)
 + Compatible with Norton Speed-Lok® TS back-up pads. (Speed-Lok® TS is a registered trademark of Norton Co.)

TRIM-KUT® DISCS

Trim-Kuts are abrasive discs designed for light grinding and blending applications on a variety of materials. The abrasive grains are fused directly onto a wearable polymer backing, resulting in a disc that requires no back-up pad. The polymer backing trims during use to expose new grains to the work surface. 3" discs are designed for use on right angle air die grinders, and 4-1/2" discs are for use on right angle grinders.

APPLICATIONS

- Edge blending
- Light weld and stock removal
- Preparation for painting and surface finishing
- Deburring



Deburring and chamfering a section of pipe after cutting.



P TRIM-KUT® DISCS - Aluminum Oxide

Diameter	Arbor Hole	Grit Size	Max. RPM	Standard Pack	Item Number
3"	5/16" - 18	36	21,000	25	59300
		60			59305
		120			59315

Do not use TRIM-KUT discs in temperatures lower than 48° Fahrenheit. Store at 50% relative humidity.



P TRIM-KUT DISC - Aluminum Oxide

Diameter	Arbor Hole	Grit Size	Max. RPM	Standard Pack	Item Number
4-1/2"	7/8"	36	13,000	25	59403 •

Do not use TRIM-KUT discs in temperatures lower than 48° Fahrenheit. Store at 50% relative humidity.



P TRIM-KUT ADAPTERS

Description	For Use With	Standard Pack	Item Number
1/4" Mandrel	3" TRIM-KUT Discs	25	59327
3/8"-24 UNF Adapter	3" TRIM-KUT Discs	25	59326 •
Adapting Nuts	4-1/2" TRIM-KUT Discs	1	56485
Spanner Wrench	Item No. 56485 only	1	56496 •



Key:

P Performance line
Industrial Grade

V Value line
Professional Grade

• Non-stock product, contact Customer Service for lead times and minimum order quantities.

COATED ABRASIVE FLAP WHEELS



Weiler's abrasive flap wheels are designed with a solid hub construction that enables wheels to be rated at higher RPMs and provide more aggressive cutting action and increased productivity. They provide perfect balance leading to smooth, chatter-free finishing.

APPLICATIONS

- Internal diameter cleaning
- Finishing metal surfaces
- Deburring machined parts
- Cleaning and reconditioning pipe threads
- Polishing, blending & finishing
- Prepping surface for painting or plating
- Edge blending



Removing burrs from the inside diameter of a cut tube.



52010



52027



P TIGER® MOUNTED FLAP WHEELS - 1/4" Stem - Aluminum Oxide

A premium line designed to provide long life. Ideal for medium to high production environments.

Diameter	Width	Grit Size	Max. RPM	Standard Pack	Item Number
1"	1"	60	30,000	10	52003
		80			52004
		120			52005
1-1/2"	1"	60	25,000	10	52009
		80			52010
		120			52011
2"	1/2"	60	25,000	10	52366
	80	52367			
2"	1"	60	25,000	10	52015
		80			52016
		120			52017
2-1/2"	1"	60	23,000	10	52486
		80			52487
3"	1/2"	60	23,000	10	52024
		80			52025
3"	1"	60	23,000	10	52027
		80			52028
		120			52029



52621

P TIGER MOUNTED FLAP WHEELS - 1/4"-20 Threaded Stem - Aluminum Oxide

A premium line designed to provide long life. Ideal for medium to high production environments.

Diameter	Width	Grit Size	Max. RPM	Standard Pack	Item Number
1"	1"	60	30,000	10	52601
2"	1"	60	25,000	10	52611
		80			52613
3"	1"	60	20,000	10	52621
		80			52623 •

NOTE

- Drive arbor is used individually and must be ordered individually.
- Drive arbor is to be used with Weiler flap wheels only.
- Stems must be fully chucked before using and should not be run above the maximum RPM listed.

Key:

P Performance line
Industrial Grade

V Value line
Professional Grade



Wolverine Flap Wheels offer a high cut rate at a cost-effective price. The smart option for use in medium production environments.

APPLICATIONS

- Internal diameter cleaning
- Polishing, blending & finishing
- Finishing metal surfaces
- Prepping surface for painting or plating
- Deburring machined parts
- Cleaning and reconditioning pipe threads



WOLVERINE® 1/4" STEM MOUNTED FLAP WHEELS

Provide fast cutting action at a value price. Ideal for low to medium production environments.

Diameter	Width	Grit Size	Max. RPM	Standard Pack	Item Number	
					Aluminum Oxide	
5/8"	5/8"	40	30,000	10	30711 •	
		60			30712	
		80			30713	
3/4"	3/4"	40	30,000	10	30715	
		60			30716	
		80			30717	
1"	1"	40	30,000	10	30719	
		60			30720 ✓	
		80			30721 ✓	
		120			30722	
1-1/2"	1"	40	25,000	10	30771	
		60			30772	
2"	1"	40	25,000	10	30732	
		60			30723 ✓	
		80			30724 ✓	
		120			30725	
3"	1"	40	23,000	10	30729	
		60			30726 ✓	
		80			30727 ✓	
		120			30728	

✓ ✓ Display Packed & Vending Ready product available, add P or V to the end of item number when placing order.



30712



30720



30724



30735



07756



03835

WOLVERINE 1/4"-20 THREADED STEM MOUNTED FLAP WHEELS

Provide fast cutting action at a value price. Ideal for low to medium production environments.

Diameter	Width	Grit Size	Max. RPM	Standard Pack	Item Number	
					Aluminum Oxide	
1"	1"	60	30,000	10	30745	
		80			30746 •	
2"	1"	60	25,000	10	30737	
		80			30738	
3"	1"	60	20,000	10	30735	
		80			30736	

DRIVE ARBOR - For 1/4"-20 Mounted Flap Wheels

Thread Size	Adapted Size	Standard Pack	Item Number
1/4"-20	1/4"	5	07756

METAL ADAPTERS - For Unmounted Flap Wheels. Used in pairs and priced per pair.

Wheel Arbor Hole Size	Adapted Arbor Hole Size	Standard Pack	Item Number
1"	3/4"	1	03835 •

• Non-stock product, contact Customer Service for lead times and minimum order quantities.

NON-WOVEN ABRASIVES

FINEST AT THE FINISH

Non-woven abrasive products can be used in a broad range of surface-conditioning applications from cleaning and finishing to deburring and light blending. Unlike bonded and coated abrasives, they cannot be used for applications requiring heavy stock removal such as grinding and weld blending.

Technical Information	52
Strip Discs	53
Surface Conditioning Discs	54
Unitized Wheels	55
Interleaf Flap Wheels	56
Hand Pads	56

SELECTING THE RIGHT PRODUCT

The various grades of non-woven products produce scratch patterns that can be compared to those produced by coated abrasive products. However, their pliable nature results in a softer, less pronounced scratch-line pattern. The strength of these products is producing decorative finishes ranging from satin to near-mirror polish.

Denser non-woven products are suitable for applications requiring light stock removal such as removing large, well-attached burrs and blending minor tool marks and imperfections.

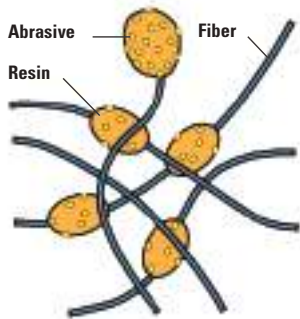

All non-woven products are fabricated from base materials that are composed of a random “web” of nylon fibers that have been bonded together with synthetic resins and impregnated with abrasive grains. Although these materials vary in fiber density, their three dimensional nature results in specialty abrasive products that are pliable, conformable to the work surface, and limited in their ability to remove base stock.

Non-woven products resist loading and perform consistently as new, fresh abrasive grains are exposed as the nylon fibers wear away from the product during use. Non-woven abrasives can be used either wet or dry on a range of materials including ferrous and non-ferrous metals, ceramics, plastics, composites, and wood. Non-woven products are designed for use where stock removal is not required. Non-wovens begin where coated abrasives leave off.

Grade	Grit Range
Ultra Fine	600
Very Fine	240-360
Fine	180-220
Medium	100-150
Coarse	50-80
Extra Coarse	24-40

STRIP DISCS



Weiler Tiger strip discs offer exceptional cleaning power and product life on steel and stainless steel. Tiger Ceramic maximizes productivity with aggressive cleaning, while Tiger SiC ensures high initial cut for hard surfaces. The flexible non-woven nylon fiber and resin formula enhances productivity and disc life for exceptional material removal and cleaning efficiency.

FEATURES & BENEFITS

- Conformable design increases the contact area with the work surface
- Industry-leading material removal and cleaning speed maximizes productivity
- Contaminant-free formula provides a worry-free solution for stainless steel
- Extra coarse grain aggressively cleans the surface and prepares it for finishing



Weld cleaning with a strip disc.

NEW

P MAX PERFORMANCE / TIGER CERAMIC

Superior Cleaning & Life
Ceramic Alumina / Contaminant-free*

STEEL / METAL **STAINLESS** **NON-FERROUS**

Diameter	Grit	Max. RPM	Std. Pack	TYPE 27	
				7/8" Arbor	5/8"-11 Hub
				Item #	Item #
4-1/2"	XC (Extra Coarse)	12,000	10	51768	51769

Diameter	Grit	Max. RPM	Std. Pack	TYPE 27	
				R Mount	
				Item #	
2"	XC	15,000	25	51763	
3"	XC (Extra Coarse)	12,000	15	51765	



51765

51768

*Contaminant-free (Contains less than 0.1% Fe, S, Cl)

NEW

P HIGH PERFORMANCE / TIGER SiC

Fast Cleaning & Long Life
Silicon Carbide / Low Sparking & Hard Surfaces

STEEL / METAL **STAINLESS**

Diameter	Grit	Max. RPM	Std. Pack	TYPE 27	
				7/8" Arbor	5/8"-11 Hub
				Item #	Item #
4-1/2"	XC (Extra Coarse)	12,000	10	51766	51767

Diameter	Grit	Max. RPM	Std. Pack	TYPE 27	
				R Mount	
				Item #	
2"	XC	18,000	25	51762	
3"	XC (Extra Coarse)	13,500	15	51764	



51762

51767

30% More material removed over the life of the disc.

20% Faster cleaning than the industry leader.

COATED ABRASIVES

NON-WOVEN ABRASIVES

POWER BRUSHES

NYLON BRUSHES

PACKAGED ITEMS

MAINTENANCE

SURFACE CONDITIONING DISCS



Surface Conditioning Discs have an open construction, scrim reinforcement and a superior resin system. These features minimize loading, heat build-up, fraying of disc edges, grain shedding and extend disc life, providing superior performance.

APPLICATIONS

- Light deburring
- Surface preparation
- Blending light scratches
- Removing rust, corrosion and oxidation
- Cleaning and removing stains from stainless steel
- Producing satin finishes on aluminum and stainless steel

Finishing the surface for a stainless steel part for the food service industry.



P TYPE R HUB STYLE DISCS - General Purpose

Compatible with 3M Roloc™ back-up pads.



Diameter	Grade	Standard Pack	Item Number
2"	Very Fine (Blue)	50	51530
	Medium (Maroon)		51531
	Coarse (Brown)		51532
3"	Very Fine (Blue)	25	51533
	Medium (Maroon)		51534
	Coarse (Brown)		51535

TYPE R HUB STYLE BACK-UP PADS - 1/4" Stem



Diameter	Max. RPM	Standard Pack	Item Number
2"	30,000	1	51551
3"	20,000	1	51552

Do not exceed maximum RPM of back-up pad.



P HOOK & LOOP STYLE DISCS



Diameter	Grade	Standard Pack	Item Number
4-1/2"	Very Fine (Blue)	10	51512
	Medium (Maroon)		51513
	Coarse (Brown)		51514
5"	Coarse (Brown)	10	51517
7"	Very Fine (Blue)	10	51521
	Medium (Maroon)		51522
	Coarse (Brown)		51523



HOOK & LOOP STYLE BACK-UP PADS

Diameter	Arbor Hole or Stem Size	Max. RPM	Standard Pack	Item Number
3"	1/4" Stem	18,000	1	51562 •
4-1/2"	5/8" -11 Arbor	13,000	1	51569
5"	5/8" -11 Arbor	10,000	1	51575
7"	5/8" -11 Arbor	6,000	1	51578

• Non-stock product, contact Customer Service for lead times and minimum order quantities.

UNITIZED WHEELS

FEATURES & BENEFITS

- Ideal for use in a broad range of surface conditioning applications from cleaning and finishing to deburring and light blending
- Can be used in wet and dry applications
- Resist loading and perform consistently as new, fresh abrasive grains are exposed
- Designed for use on die grinders



A unitized wheel deburring a ring gear.



P

UNITIZED WHEELS - Designed for use on die grinders and are ideal for a variety of cleaning, finishing, deburring and edge blending applications.

Diameter	Face Width	Arbor Hole	Grain	Grade	Max. RPM	Standard Pack	Item Number
Series 2 - Cleaning & Finishing - Hardness: Soft							
3"	1/4"	1/4"	Silicon Carbide	Fine	12,000	10	55513 •
Series 6 - Deburring - Hardness: Medium/Hard							
3"	1/4"	1/4"	Aluminum Oxide	Fine	18,000		54492
Series 8 - HD Deburring & Polishing - Hardness: Hard (Heavy-Duty)							
3"	1/8"	1/4"	Aluminum Oxide	Coarse	18,000	10	55546
	1/4"			Medium			55541
	1/2"			Medium			55542



55513



55541



56489

MANDRELS

Stem Diameter	For Wheel Diameter	For Wheel Thickness	Standard Pack	Item Number
1/4"	2" - 3"	1/2"	1	07761
	1"	1"	1	07764 •
	2" - 3"	1/8" - 1/4"	10	56489

• Non-stock product, contact Customer Service for lead times and minimum order quantities.

COATED ABRASIVES

NON-WOVEN ABRASIVES

POWER BRUSHES

NYLOX BRUSHES

PACKAGED ITEMS

MAINTENANCE

INTERLEAF FLAP WHEELS



Deburring the I.D. of a steel pipe with an interleaf flap wheel.



Interleaf Flap Wheels provide a combination of non-woven and coated abrasive material to produce a very conformable product compared to a standard coated abrasive flap wheel. They are designed to be a finishing and surface blending tool as compared to a material-removing coated abrasive flap wheel. They are ideal for producing satin or decorative finishes on irregular or contoured surfaces.

APPLICATIONS

- General decorative finishing
- Applying satin finishes
- Producing antique finishes
- Final sandings
- Soft metal finishing
- Removing oxides from precious metals
- Fine burr removal



P STEM-MOUNTED INTERLEAF FLAP WHEELS - Aluminum Oxide

Diameter	Face Width	Grit Size	Stem Size	Max. RPM	Standard Pack	Item Number
2"	1"	120	1/4"	13,700	10	54500
		180				54501
		320				54502
3"	1"	120	1/4"	8,600	10	54506
		180				54507
		320				54508
3"	2"	120	1/4"	8,600	10	54509
		180				54510

HAND PADS



Polishing a rail axle journal with a non-woven hand pad.

INDUSTRIAL GRADE:

- Producing satin finishes on aluminum and stainless steel
- Light deburring
- Surface preparation
- Blending light scratches

COMMERCIAL GRADE:

- Cleaning and removing stains from stainless steel
- Removing rust, corrosion and oxidation

P HAND PADS - For cleaning and conditioning surfaces by hand. Unlike steel wool, hand pads are non-metallic, and do not produce "after-rust" on work surfaces. Hand pads can be used in wet applications.

Size	Grain	Grade	Description	Standard Pack	Item Number
Industrial Grade					
6" x 9"	Silicon Carbide	Ultra Fine	Finishing (Grey)	60	51434
6" x 9"	Aluminum Oxide	Medium	Economy General Purpose (Maroon)	60	51460
6" x 9"	Aluminum Oxide	Med/ Coarse	General Purpose (Maroon)	60	51444
6" x 9"	Aluminum Oxide	Heavy-Duty	Heavy-Duty (Tan)	40	51454
Commercial Grade					
6" x 9"	Aluminum Oxide	Fine	Economy (Green)	400	51456
6" x 9"	Aluminum Oxide	Medium	Standard-Duty (Green)	60	51457

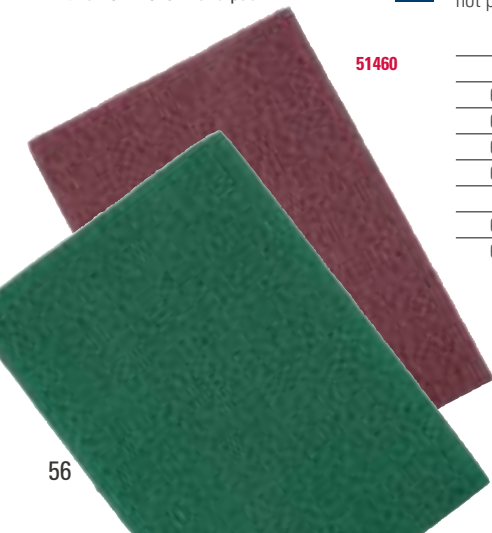



POWER BRUSHES

CHOOSE QUALITY

Superior construction, the highest quality materials, state of the art manufacturing and exacting quality standards deliver the most consistent brush performance. Each Weiler brush is designed to provide the best performance at the lowest cost-of-use.

Superior performance is now even easier to see. Our most popular stainless steel brushes are now color-coded black for easy identification, even during operation. See the items bold in black throughout this section.

Technical Information	60-66
Knot Wire Wheels	67-73
Weld Cleaning Brushes	72-73
Crimped Wire Wheels	74-81
Nylon & Tampico Wheels.....	82
Cup Brushes	83-85
Stem-Mounted End Brushes.....	86-89
Crosshole Deburring Brushes	90
Power & Hand Tube Brushes.....	91-95
Crossflex Honing Brushes.....	96-98
Miniature Brushes	100-101
Non-Sparking Brushes	102-103
Wide Face Brushes	104-105



Display Packaged and Vending Ready Products Brochure

P display pack and **V** vending pack items are indicated throughout this catalog. See our brochure for the full line.

SOLUTIONS SHOWCASE

TUBE END DEBURRING

Problem: Structural tubing is fabricated into an abundance of different forms. In order to facilitate safer handling and proper fit, the ends of the tubing must frequently be deburred.

Solution: Wide face crimped wire wheel brushes are an extremely effective solution for tube end deburring. Brushes can deburr the OD and ID of tubing at an extremely high rate and produce a media-cost-per-part of considerably less than \$0.01 per part.



GEAR DEBURRING

Problem: Power transmission components like gears cannot function properly when burrs prevent correct engagement. Further, burrs that become detached from gears can become lodged in critical transmission components causing premature wear and potential failure.

Solution: Knot wire wheel brushes with surface speed in excess of 6,000 SFPM are an excellent solution for deburring gears prior to heat treatment. The high energy filament tips are able to separate burrs from base material and produce a uniform edge break, which protects the edge of the gear.

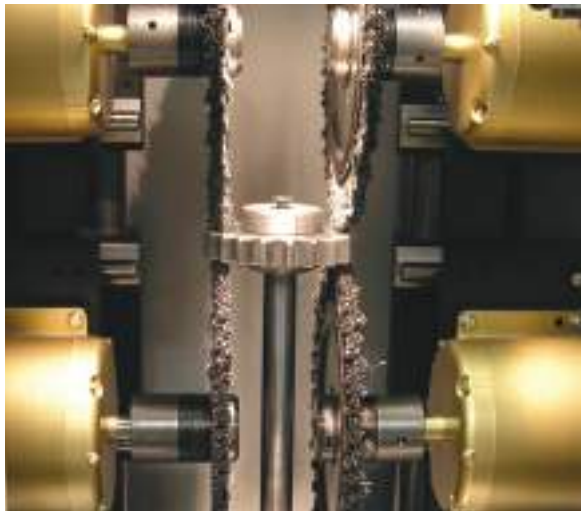

Photos courtesy of On-Line Services.

REMOVAL OF MILL SCALE

Problem: Mill processing of steel often involves heat treating and oil quenching operations that produce an adherent scale, which must be removed prior to joining or finishing operations.

Solution: Wire brushes are capable of quickly cleaning material to white metal and producing varying degrees of surface roughening to promote adhesion. Brushing operations are often preferred over blasting and chemical processes that generate an expensive waste stream and can be costly to operate and maintain.



INTER-PASS PIPELINE WELD CLEANING



Problem: To prevent voids and inclusions when welding multi-pass joints, the surface of each bead must be completely cleaned of slag and other residuals. Performing inter-pass weld cleaning as quickly and as thoroughly as possible is critical to avoiding costly repair work and delays.

Solution: Weiler's Roughneck® and Dually® stringer bead wheels have been engineered to maximize efficiency and minimize costs and are the preferred choice of welders' helpers on the pipeline. From hot pass to cap pass, these premium weld cleaning brushes excel at quickly and thoroughly removing slag, spatter, and oxidation without damaging the filler material.

CLEANING THREADED CONNECTIONS

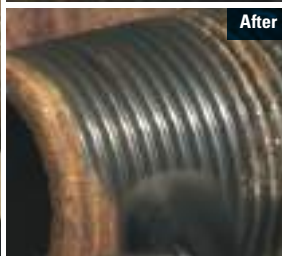

Problem: The box ends of drill string and other oilfield tubular goods are examples of connections that must be periodically cleaned without altering the geometry of the threads. Abrasive products all remove base material to some extent and are capable of damaging threads, resulting in unreliable connections and the risk of potential failures.

Solution: The conformability and impact action of small diameter crimped wire wheels make them ideal tools for cleaning threads without fear of damage. When used on a high-speed die grinder, these radial wheel brushes quickly remove residual dope as well as rust, corrosion and scale from male or female thread ends.

REMOVAL OF EXCESS MOLDED RUBBER



Problem: Mechanical rubber components such as motor mounts are produced through a process that commonly leaves flash and excess rubber on critical surfaces. In order for the component to function properly, this unwanted material must be removed.

Solution: The non-loading nature of wire brushes makes them the best available solution in the marketplace for removal of rubber from targeted surfaces. This solution can be implemented off-hand or using automated equipment.

SELECTING THE RIGHT BRUSH

SELECTION BY TOOL

	Crimped Wheels	Knot Wheels	Crimped Cups	Knot Cups	Crimped Stem-Mtd. Wheels	Knot Stem-Mtd. Wheels	Crimped Stem-Mtd. End	Knot Stem-Mtd. End	Encapsulated Brushes	Power & Hand Tube Brushes	Mini Brushes
Right Angle Grinder	✓	✓	✓	✓					✓		
Straight Grinder	✓	✓			✓	✓	✓	✓	✓		
Die Grinder	✓	✓			✓	✓	✓	✓	✓		
Corded/Cordless Hand Drill					✓	✓	✓	✓		✓	
High Speed Pencil Grinder											✓
Bench/Pedestal Grinder	✓	✓							✓		
Drill Press					✓	✓	✓	✓		✓	
CNC/Milling/Automatic Machine	✓	✓	✓	✓	✓	✓	✓	✓	✓	✓	

WIRE SIZE

To maximize brush life and reduce costs, always use the finest wire that will accomplish the job without requiring excessive applied pressure or engagement with the brush face.

Wire Gauge #	Coarse		Medium to Coarse		Medium		Fine		Very Fine	
20	24	25	30	33	34	35	38	43	47	
Dia. in Inches	.035	.023	.020	.014	.0118	.0104	.0095	.008	.006	.005
Dia. in Millimeters	0,89	0,58	0,51	0,36	0,30	0,26	0,24	0,20	0,15	0,13

Wire sizes in decimals of an inch are shown in all tables throughout this catalog. American Steel Wire Equivalent Gauge (Formerly Washburn & Moen)

LARGE DIAMETER WIRE

- Aggressive brushing action
- Fatigues and breaks more quickly

SMALL DIAMETER WIRE

- Resists fatigue and breakage
- Less aggressive
- Flexible brushing action

CRIMPED VS. KNOT WIRE

CRIMPED WIRE BRUSHES:



- Greater flexibility for light/medium duty applications.
- Use on parts that could be damaged by the impact of a knot brush.
- Use for a broad range of applications.

KNOT WIRE BRUSHES:



- Straight wire filaments that are twisted as a single unit like a piece of cable or wire rope.
- Provide less flexibility and more aggressive brushing action in heavy-duty applications.
- Use on parts requiring high-impact action.
- Use to remove large burrs and heavy contamination, such as multiple layers of rust, scale, paint or oxides.

KNOT TWIST CONFIGURATIONS



STANDARD

Provides some flexibility for use on irregular surfaces. Sharp wire tips make this knot aggressive right from the start.



HURRICANE

Provides smoother operation but sacrifices much of the cleaning action.



CABLE

Provides very aggressive brushing action. Sharp wire tips make this knot aggressive right from the start.



STRINGER BEAD

High-impact action, primarily for weld cleaning. Sharp wire tips make this knot aggressive right from the start.

TRIM LENGTH & FILL DENSITY

To maximize brush life and reduce costs, always use the shortest trim, highest density brush that will adequately conform to the surface or part edges.

LONG TRIM, LOW DENSITY BRUSHES

- Flexibility that is ideal for applications such as cleaning surfaces that are somewhat irregular
- Lower fill density can result in shorter brush life and less consistent performance in production environments.

SHORT TRIM, HIGH DENSITY BRUSHES

- Less flexible and faster action requires less applied pressure
- Consistent performance and longer life



WHY WEILER
BONDED ABRASIVES
COATED ABRASIVES
NON-WOVEN ABRASIVES
POWER BRUSHES
NYLON BRUSHES
PACKAGED ITEMS
MAINTENANCE

POLYFLEX® ENCAPSULATED

These brushes are suitable for extremely demanding applications that do not require a high degree of conformability. They are especially well-suited for users with the following types of requirements:

Extreme brushing pressure - Encapsulation protects wires from over-flexing and extends brush life relative to conventional knot and crimped wire brushes.

Severe cleaning operations - Encapsulation holds the wire tips rigidly in place and creates the most aggressive brushing action that can be achieved with a wire brush.

BURGUNDY (STANDARD)

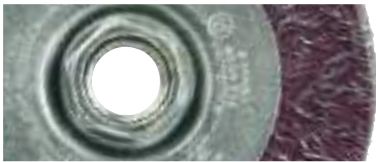

General purpose elastomer; suitable for most manufacturing applications.

ORANGE (HEAVY-DUTY)



A more heavy-duty elastomer than burgundy; used for more demanding applications.

BLACK (EXTRA HEAVY-DUTY)



A heat stabilized elastomer that does not wear easily; used primarily for cleaning welds.

ARBOR HOLE VARIATIONS

FOR WEILER PERFORMANCE LINE WHEELS

If an arbor hole size other than the size listed in the product table is required, change the last digit of the Item Number as indicated in the Table.

Arbor Hole Diameter	Arbor Hole Features	Change Last Digit of Item # To:
1/2"-3/8"	Plastic Snap-Out Adapter	4
5/8"-1/2"	Plastic Snap-Out Adapter	5
5/8"-11 UNC	Threaded Nut (6", 7" & 8" Wheels Only)	6
5/8"	3", 4" & 6" Wheels Only	7
3/4"	—	8
7/8"	—	0 - 11
1"	1/4"*x 1/8"+ double keyway	0 - 12
1-1/4"	5/16"*x 5/32"+ double keyway	9
1-1/2"	3/8"*x 3/16"+ double keyway	0 - 13
1-3/4"	3/8"*x 3/16"+ double keyway	0 - 16
2"	1/2"*x 1/4"+ double keyway	0 - 14
2-1/4"	3/4"*x 3/8"+ double keyway	0 - 17
2-1/2"	1/2"*x 1/4"+ double keyway	0 - 15

* Width of keyway

+ Depth of keyway

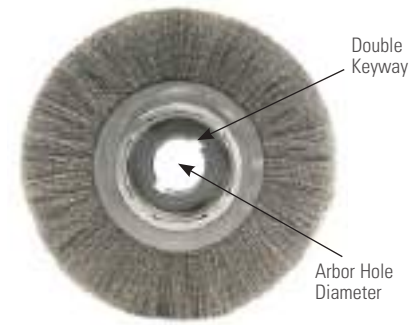

Example: Item Number 01228 has a listed, standard size arbor hole of 3/4". If an 1-1/4" arbor hole is desired, drop the 8 from 01228 and add 9. The Item Number becomes 01229. If a 1" arbor hole is desired, drop the 8 from 01228 and add 0-12. The Item Number becomes 01220-12.

PRODUCT ADVANTAGES

PRODUCT LINE STRUCTURE

P PERFORMANCE LINE (INDUSTRIAL GRADE)

Engineered and manufactured to maximize performance and minimize operating costs in the most demanding surface conditioning applications. The use of superior construction, the highest quality materials and the most stringent manufacturing processes deliver the lowest cost-of-use and most consistent performance in heavy production environments.

V VALUE LINE (PROFESSIONAL GRADE)

Weiler's value line is manufactured using similar product construction and the same exacting standards as other Weiler power brushes, but engineered to provide cost-effective use in less demanding environments. Wolverine™ brushes (Formerly Vortec Pro®) are an economical choice for the construction trades, low volume production shops and light duty industrial MRO use.

OPERATIONAL ADVANTAGES

POWER BRUSHES DO NOT REMOVE BASE MATERIAL

- The impact action of the wire tips of a rotating brush behave in the same manner as the media in a blasting operation and they have the same ability to separate surface contaminants without damaging the substrate.
- Due to its compliant nature, a power brush is the ideal tool for removing burrs and blending sharp edges without changing overall part dimensions after sawing, cutting, grinding and machining operations.

Grinding Wheel



Wire Wheel



POWER BRUSHES DO NOT LOAD

Unlike bonded, coated and non-woven abrasive products, power brushes will not load when used on softer materials or when removing paint or similar coatings from a harder surface. Because a power brush consists of a collection of individual wire filaments, there is no place for debris to accumulate and prevent the sharp wire tips from striking the work.

Resin Fiber Disc



Wheel Brush



POWER BRUSHES ARE SELF-SHARPENING

As a power brush is used, the wire tips will naturally tend to wear to a point due to contact with the working surface. It is possible to take advantage of this self-sharpening action by periodically switching the mounting position of wheel brushes to maintain their speed and effectiveness.

WEILER SUPERIOR CONSTRUCTION



WEILER'S SOLID RING CONSTRUCTION

Our crimped wire brushes are constructed using solid rings to retain the fill material and our manufacturing process results in an even, consistent distribution of wire strands around the entire brush diameter. This ensures that our crimped wire products run smoother and last longer than the competition – even in the toughest applications.



WEILER'S INDIVIDUAL KNOT HOLE CONSTRUCTION

Weiler's knot wheels are constructed with an internal steel plate that has equally spaced individual holes around the perimeter. Wire is inserted through each hole and twisted into a knot. Each hole has precisely the same wire count, thereby assuring perfect balance. This eliminates vibration, reduces operator fatigue and increases brush life.

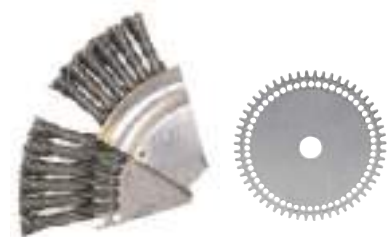

WEILER'S ROUGHNECK® WELD CLEANING BRUSH CONSTRUCTION

Each knot is twisted through its own hole and locked into an individual sprocket tooth. This prevents the knots from moving, providing a stronger striking action on the work surface, longer brush life and less operator fatigue. This results in the most aggressive weld cleaning in the market with the lowest cost-per-piece brushed.

PRODUCT CHARACTERISTICS

WHEEL BRUSH

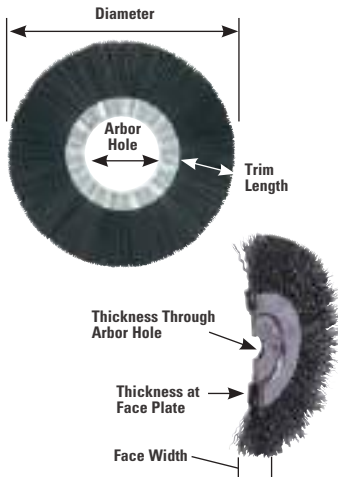

CUP BRUSH



END BRUSH



TUBE BRUSH

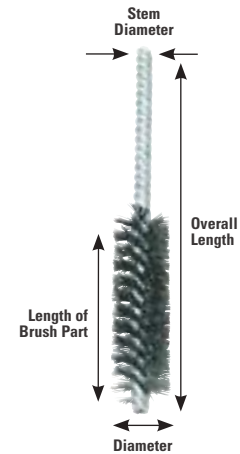

FILL MATERIALS



Steel Wire - Carbon steel wire is the most durable power brush fill material for metalworking and heavy-duty cleaning applications. **Weiler industrial grade brushes** utilize heat treated, high tensile steel wire that has been drawn to the most exacting industry standards for superior fatigue resistance and aggressive brushing action. **Wolverine® brushes** utilize more cost-effective grades of steel wire to deliver reliable performance in less demanding applications.



Stainless Steel Wire - Stainless steel wire is only recommended when brushing corrosion-resistant or non-ferrous metals such as stainless or aluminum or when the brush is being used in a wet environment. Stainless steel wire is not any more durable or aggressive than the highest grades of steel wire. All Weiler stainless steel brushes are manufactured with Type 302 stainless wire, but select items are also available with Type 316 wire by special order.



Non-Ferrous Wire - Brass, bronze and aluminum wire are available in assorted Weiler industrial grade power brush items. These non-ferrous materials will not generate a spark in use, but they lack the durability of carbon steel and stainless steel wire. Due to their soft brushing action, these materials may also be used in special applications such as decorative finishing.



Animal Hair - Natural hair bristle is used primarily in miniature power brushes for scratch-free cleaning and polishing. Depending on the animal species and type of hair, this fill material can range from relatively stiff to relatively soft, making it suitable for a variety of applications from removing dust from optical lenses to buffing precious metals using abrasive compounds.



Vegetable Fiber - Tampico, a natural fiber produced from the Mexican agave plant, is a common natural fill material used in wet scrubbing and cleaning applications as well as buffing and polishing metals. It is heat, alkali and acid resistant. Its natural color is off-white but it may be dyed or bleached.



Synthetic - Nylon is typically the most durable synthetic bristle material for use in power brushes and can be used in a variety of applications due to its flexibility, high fatigue strength and resistance to abrasion, heat, acids and alkali. Polypropylene is less durable and used primarily in strip brushes.

STAINLESS STEEL BRUSHES

Weiler's stainless steel wire brushes are manufactured using wire drawn from Type 302 stainless steel. Although 302 stainless is typically a non-magnetic material, it is important to remember that the amount of cold-working that it experiences during the wire-drawing process causes it to become magnetic. For this reason, proper storage and handling of stainless steel brushes is critical to prevent cross-contamination and "after rust" issues. Type 302 is widely used in the manufacture of power brushes for its relative durability and aggressive action as well as for its austenitic

properties that insure the corrosion resistance of the materials on which it is applied. The use of a different grade of stainless steel wire is typically required in critical weld preparation and cleaning applications, but it will not address "after rust" and other cross-contamination issues. To insure the corrosion resistance of any stainless steel surface after brushing, passivating it with a 10-20% solution of nitric acid is recommended.

WORK SAFER WITH PROPER BRUSH USAGE

Weiler products are designed and manufactured to the strictest standards to ensure the highest level of quality and safety. But safety doesn't stop there; raising awareness of basic safety practices and thinking about safety before the job starts — and after the job is complete — can help curb accidents and injuries in the shop. That's why Weiler offers customers a Safety Training Program based on the **SPOT (Speed & Size, Pressure, Orientation, Time)** methodology to help promote safe and proper product usage.

THINK SPOT.
WHEN USING ABRASIVES & BRUSHES

Deploying our **SPOT Safety Training Program** in your facility helps improve safety, regardless of your application or work environment.

For **SPOT Safety Training** contact your Weiler representative.

SPEED & SIZE

- Power brushes, operate most effectively when the speed and pressure of the operation are properly matched to the demands of the application. In most operations, the highest speed and lightest pressure will ensure the fastest brushing action and longest brush life.
- Increasing brush speed increases the face hardness and brushing action; therefore, a fine wire brush rotating at a higher speed will often produce the same results as a coarser wire brush rotating at a slower speed. Finer wire operating at a higher speed is generally preferred and will provide a longer brush life.
- MSFS - Maximum Safe Free Speed (RPM) is the maximum speed at which the brushes may be used safely but is not necessarily the optimum speed for a given application. Operating speed should be determined by the application. When running a wire

brush, a rule of thumb is to run it a "mile a minute" or a minimum of 5,000 Surface Feet Per Minute (SFPM). However, never exceed the Maximum Safe Free Speed of the brush.

- Make sure spindle size and motor of machine are large enough to accommodate the diameter of brush to be used (see table on pg. 55).



Match the RPM rating of the power brush to the tool being used. The RPM of the tool should never exceed the RPM of the power brush.

RECOMMENDED SURFACE SPEEDS FOR BRUSHING APPLICATIONS

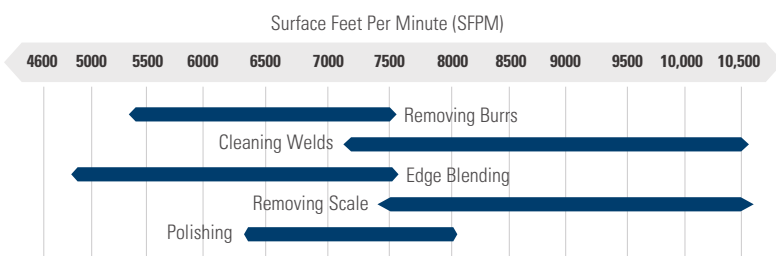

$$SFPM = \frac{\pi \text{ Dia. (Inches)} \times RPM}{12}$$

SURFACE SPEEDS (PERIPHERAL SPEED IN FT./MIN.)

RPM	Diameter (Inches)							
	2	3	4	6	8	10	12	15
1000	525	785	1,050	1,575	2,100	2,625	3,150	3,925
1500	785	1,175	1,575	2,350	3,150	3,925	4,725	5,900
1750	915	1,375	1,850	2,750	3,650	4,550	5,500	6,800
2500	1,300	1,950	2,625	3,925	5,250	6,550	7,850	9,825
3000	1,575	2,350	3,125	4,725	6,275	7,850	9,425	11,775
3450	1,800	2,700	3,600	5,400	7,200	9,000	11,000	13,500
4000	2,100	3,150	4,175	6,275	8,375	10,475	—	—
6000	3,125	4,700	6,275	9,425	—	—	—	—
10,000	5,250	7,850	10,500	—	—	—	—	—
15,000	7,850	11,775	15,750	—	—	—	—	—
20,000	10,450	15,700	20,950	—	—	—	—	—

Example: A 6" diameter wheel running at 3,450 RPM has a surface speed of 5,400 SFPM.

MINIMUM RECOMMENDED SPINDLE DIAMETER (From ANSI Standard B165.1)

Outside Dia. of Wheel Brush	Maximum Face Width of Wheel Brush	Minimum Outside Dia. of Spindle (Shaft)
2"	1/4"	1/4"
3"	3/4"	1/4"
3" (heavy-duty)	1"	3/8"
4"	1"	3/8"
6"	1-1/4"	1/2"
8"	1-1/4"	5/8"
10"	2"	3/4"
12"	3"	1"
14"	3"	1-1/4"
15"	3"	2"
16"	3"	2"

Note: These diameters are based on the wheel brush being mounted next to the supported end of the shaft rather than the unsupported end in order to minimize overhang.

RECOMMENDED MOTOR SIZES (Based on 1" Brush Face)

Brush Diameter	Motor Size	RPM
4"	1/4 HP	3,450
6"	1/2 HP	3,450
8"	3/4 HP	3,450
10"	1 HP	1,750
12"	1 HP	1,750
15"	1-1/2 HP	1,750

PRESSURE

Avoid excessive pressure when using a wire brush. Excessive pressure causes over-bending of the filaments and heat build-up resulting in filament breakage, rapid dulling and reduced brush life.

INSTEAD OF GREATER PRESSURE, TRY:

- A brush with more aggressive action (increase filament diameter, decrease trim length, different brush type, i.e.: knot type instead of crimped type.
- Higher surface speed (increase RPM or brush diameter)

Never exceed the recommended Maximum Safe Free Speed or RPM rating of the brush.



Correct
Wire Tips Doing the Work

Incorrect
Excessive Pressure Causes Wire Breakage

ORIENTATION

WORKING ANGLE BY BRUSH TYPE

Never stray more than 15° from the suggested working angles of the brush configurations below.

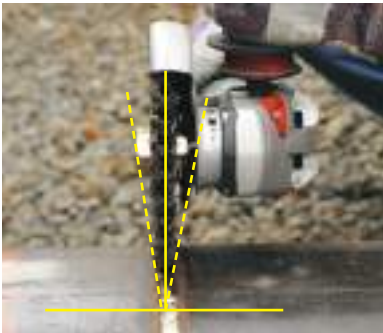

WHEEL +/- 15°



CUP +/- 15°



BEVEL +/- 15°

TIME

Reduce the time it takes to get the job done by choosing the most appropriate product configuration. (See page 63 for product selection information.)

SELF-SHARPENING OF WIRE WHEEL BRUSHES

When using wire wheel brushes without nuts, periodically reverse the direction of rotation to take advantage of the self-sharpening action that will result. Remove the brush from the spindle, flip the wire brush 180° and remount the brush securely.



Remove



Flip 180°



Remount Securely

POWER BRUSH TROUBLESHOOTING GUIDE

There are many variables in power brush applications. If the power brush you are using does not accomplish the desired results, select a solution from the suggestions below for your specific application.

Problem	Recommended Solutions
Brush works too fast	<ul style="list-style-type: none"> • Select a brush with longer filaments and/or lower fill density • Select a brush with a smaller diameter wire • Select a brush with a narrower face and/or lower fill density • Select a brush with a smaller outside diameter • Operate the brush at a slower RPM
Brush works too slowly	<ul style="list-style-type: none"> • Select a brush with shorter filaments and/or higher fill density • Select a brush with a larger diameter wire • Select a brush with a wider face and/or higher fill density • Select a brush with a larger outside diameter • Operate the brush at a faster RPM
Brushing action rolls or peens the burr over instead of removing burr	<ul style="list-style-type: none"> • Select a brush with a larger diameter wire • Select a brush with shorter filaments and/or higher fill density • Operate the brush at a faster RPM • Replace the crimped wire brush with a knot wire brush
Finer final finish required	<ul style="list-style-type: none"> • Select a brush with longer filaments • Select a brush with a smaller diameter wire • Operate the brush at a higher RPM • Replace the wire brush with a nylon abrasive brush (Nylox-)
Coarser final finish required	<ul style="list-style-type: none"> • Select a brush with shorter filaments • Select a brush with a larger diameter wire • Operate the brush at a slower RPM
Non-uniform brushing action	<ul style="list-style-type: none"> • Select a brush with longer filaments • Select a brush with a larger diameter wire • Automate the operation to reduce human variables
Filaments break off	<ul style="list-style-type: none"> • Reduce applied pressure or engagement • Select a brush with a smaller diameter wire • Select a brush with a lower fill density
Short brush life	<ul style="list-style-type: none"> • Reduce applied pressure or engagement • Select a brush with a smaller diameter wire • Select a brush with a higher fill density

NEED HELP?

For more information and to schedule a consultation with a Weiler Process Solutions expert visit: weilerabrasives.com/wps.
To discuss specific requirements with a specialist call: 800-835.9999.



ARTICLE:

Learn how extending wire brush life creates operational savings.



KNOT WIRE WHEELS WITH ARBOR HOLE

Knot wire wheels with arbor holes are intended for use on straight grinders and stationary machines such as bench or pedestal grinders and buffing lathes. Featuring Weiler's individual knot hole construction, these radial brushes are available in heat-treated steel, Type 302 stainless steel, and bronze wire for use in a wide variety of applications.

APPLICATIONS

- Removing rust, scale and heavy corrosion
- Surface roughening and preparation
- Coating removal
- Removing excess molded rubber or plastic
- Heavy deburring



MADE IN
USA
WITH GLOBAL
MATERIALS



Removing rubber coating from a hydraulic hose.

P **STANDARD TWIST WHEELS** provide heavy-duty brushing action with some flexibility; ideal for demanding cleaning applications on somewhat irregular surfaces.

Dia.	Wire Size	Arbor Hole	No. of Knots	Face Width	Trim Length	Max. AH Avail.	Thickness at Face Plates	Max. RPM	Std. Pack	Item Number	
										Steel	Stainless
3"	.0118	1/2"-3/8"	20	3/8"	5/8"	1/2"	7/16"	25,000	10	08004	08254
	.014									08014 V	08264
	.020									08024 ▲	08274
4"	.0118	1/2"-3/8"	24	1/2"	7/8"	1/2"	7/16"	20,000	10	08034	08284
	.014									08044 ■	08294
	.020									08064	08314
4"	.014	5/8"-1/2"	24	1/2"	7/8"	7/8"	7/16"	20,000	10	08045	—
6"	.0118	5/8"-1/2"	24	1/2"	1-3/8"	1-1/4"	9/16"	9,000	10	08075	08325
										.014	—
										.016	08345
										.023	—
6"	.016	5/8"-1/2"	30	5/8"	1-1/4"	1-1/4"	5/8"	9,000	5	08975	—
7"	.014	5/8"	24	5/8"	1-7/8"	1-1/4"	9/16"	9,000	2	08835	—
8"	.0118	5/8"	38	5/8"	1-5/8"	2"	1/2"	6,000	2	08125	08375
										.014	—
										.016	08395
										.023	—
8"	.014	3/4"	38	5/8"	1-5/8"	2"	1/2"	6,000	2	08138	—
10"	.014	3/4"	52	3/4"	1-3/4"	2-1/2"	3/4"	4,500	2	08178	—
10"	.014	1-1/4" ★	52	3/4"	1-3/4"	2-1/2"	3/4"	4,500	2	08179	—
										.016	08189
12"	.014	1-1/4" ★	52	3/4"	2-3/4"	2-1/2"	11/16"	3,600	1	08209	—
										.016	08219
12"	.014	2" ◆	52	3/4"	2-3/4"	2-1/2"	11/16"	3,600	1	08200-14 •	—
12"	.020	1-1/4" ★	56	5/8"	2-3/4"	3"	13/16"	4,500	2	09719	—
12"	.023	2" ◆	66	3/4"	2-1/4"	3"	13/16"	5,000	2	09870 •	—

★ 5/16" x 5/32" Double Keyway

◆ 1/2" x 1/4" Double Keyway

▲ Available in non-sparking bronze wire, see page 102-103 for details.

BOLD BLACK ITEM numbers indicate color-coded brushes for easy identification.

■ V Display Packed & Vending Ready product available, add P or V to the end of item number when placing order.

V **WOLVERINE® STANDARD TWIST WHEELS** provide aggressive brushing action for general-purpose surface cleaning applications.

Dia.	Wire Size	Arbor Hole	No. of Knots	Face Width	Trim Length	Max. AH Avail.	Thickness at Face Plates	Max. RPM	Std. Pack	Item Number	
										Steel	Stainless
3"	.014	1/2"-3/8"	20	3/8"	3/8"	1/2"	7/16"	25,000	10	36290	—
4"	.014	1/2"-3/8"	24	5/8"	7/8"	1/2"	9/16"	20,000	10	—	36293 •
6"	.014	5/8"-1/2"	24	1/2"	1-1/4"	5/8"	9/16"	9,000	10	36227	—
8"	.023	5/8"	38	9/16"	1-5/8"	5/8"	1/2"	6,000	2	36279	—

NOTE

If a different arbor hole is required (than listed in the tables) refer to Arbor Hole Table shown on Pg. 61.

• Non-stock product, contact Customer Service for lead times and minimum order quantities.



08264



08085



08189



36293



36227

P STANDARD TWIST WHEELS - High Density & Extra High Density - Engineered for maximum performance in production applications; for use on automated equipment such as dedicated gear deburring machines.



08339

Diameter	Wire Size	Arbor Hole	Face Width	Trim Length	Thickness at Face Plates	Max. RPM	Standard Pack	Item Number Steel
80 KNOTS								
14"	.0118	1-1/4"★	3/4"	2-1/2"	5/8"	5,000	2	08309 •
	.014	1-1/4"★						08319 •
	.020	1-1/4"★						08339
15"	.020	2"◆	3/4"	3"	5/8"	5,000	2	09990
90 KNOTS								
14"	.016	2"◆	3/4"	1-1/2"	5/8"	5,000	2	09790 •
15"	.020	2"◆	3/4"	2"	5/8"	5,000	2	09840 •

★ 5/16" x 5/32" Double Keyway ◆ 1/2" x 1/4" Double Keyway



P STANDARD TWIST WHEELS - Two Section - Provide heavy-duty brushing action with some flexibility; feature a double row of knotted wire for a wider brush face.



09460



09104

Diameter	Wire Size	Arbor Hole	No. of Knots	Face Width	Trim Length	Thickness at Face Plates	Max. RPM	Standard Pack	Item Number Steel
3"	.0118	1/2"-3/8"	40	3/4"	5/8"	3/4"	22,000	5	09104
4"	.0118	1/2"-3/8"	48	3/4"	7/8"	3/4"	20,000	5	09134
6"	.0118	2"	60	7/8"	1-3/8"	7/8"	8,000	5	09160
	.016								09180
8"	.0118	2"	76	1"	1-5/8"	1"	6,000	1	09410
	.016								09430
	.023								09440
10"	.0118	2"	104	1-1/4"	1-3/4"	1-1/4"	4,500	1	09460
	.016								09480
	.023								09490
12"	.0118	2"	104	1-1/4"	2-3/4"	1-1/4"	3,600	1	09510
	.016								09530
	.023								09540

See Metal Adapters on page 76 for brushes with 2" arbor holes.

P STANDARD TWIST WHEEL - Four Section - Featuring four rows of knotted wire; for use in automated cleaning processes such as removing light mill scale from metal rod and wire.



94000

Diameter	Wire Size	Arbor Hole	No. of Knots	Face Width	Trim Length	Thickness at Face Plates	Max. RPM	Standard Pack	Item Number Steel
12"	.014	2"	208	2"	2-3/4"	1-3/4"	3,600	1	94000 •

See Metal Adapters on page 76 for brushes with 2" arbor holes.

• Non-stock product, contact Customer Service for lead times and minimum order quantities.



P **CABLE TWIST WHEELS** provide maximum brushing action with minimal flexibility; ideal for demanding cleaning and coating removal applications on relatively smooth surfaces.

Dia.	Wire Size	Arbor Hole	No. of Knots	Face Width	Trim Length	Max. AH Avail.	Thickness at Face Plates	Max. RPM	Std. Pack	Item Number	
										Steel	Stainless
4"	.020	1/2"-3/8"	24	1/4"	7/8"	1/2"	7/16"	20,000	10	08534	—
6"	.023	5/8"-1/2"	24	3/8"	1-3/8"	1-1/4"	9/16"	9,000	10	08565	08695*
8"	.023	5/8"	38	1/2"	1-5/8"	2"	1/2"	6,000	2	08615	—
		3/4"								08878	—
10"	.023	3/4"	52	1/2"	1-3/4"	2-1/2"	3/4"	4,500	2	08878	—
		1-1/4"★								08879	—
12"	.023	1-1/4"★	52	7/16"	2-3/4"	3"	3/4"	3,600	2	09379 •	—

If a different arbor hole is required (than listed) refer to the Arbor Hole Variations Table on page 61. ★ 5/16" x 5/32" Double Keyway *Standard Pack 2

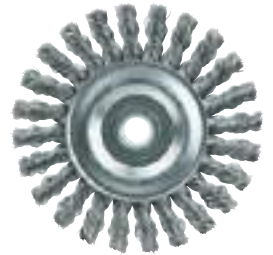

08534



94008

P **CABLE TWIST WHEEL - Four Section** - Featuring four rows of tightly knotted wire; for use in demanding automated applications such as cleaning the OD of drill pipe and other oilfield tubular goods.

Dia.	Wire Size	Arbor Hole	No. of Knots	Face Width	Trim Length	Max. AH Avail.	Thickness at Face Plates	Max. RPM	Std. Pack	Item Number
10"	.023	2"	208	1-3/4"	1-3/4"	2"	1-7/8"	4,500	1	94008

P **JOINT & CRACK CLEANING WHEELS** feature heavy-duty construction and an extra long trim length for cleaning expansion joints and cracks in concrete and asphalt.

Dia.	Wire Size	Arbor Hole	No. of Knots	Face Width	Trim Length	Thickness at Face Plates	Max. RPM	Standard Pack	Item Number
12"	.035	1" with two drive holes*	38	3/8"	3-5/8"	1/2"	5,000	2	94224
12"	.035	1" with two drive holes*	52	3/8"	2-3/4"	3/4"	6,000	2	94026

*Drive holes are 3/8" diameter with 1/4" x 1/8" double keyway.

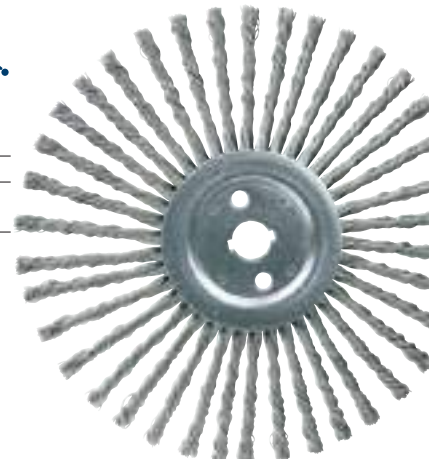

94224



04455

ADAPTER for mounting Joint & Crack Cleaning Wheels onto a 20mm arbor.

For Brush Arbor Hole Size	Adapted Arbor Hole Size	Standard Pack	Item Number
1"	20mm	10	04455

Cleaning a crack on an airport runway with a joint & crack cleaning brush prior to filling.



NOTE

If a different arbor hole is required (than listed in the tables) refer to Arbor Hole Table shown on Pg. 61.

Key:

P Performance line
Industrial Grade

V Value line
Professional Grade

• Non-stock product, contact Customer Service for lead times and minimum order quantities.

KNOT WIRE WHEELS WITH NUT



Cleaning a corner weld with a bevel brush.

MADE IN
USA
WITH GLOBAL
MATERIALS



Knot wire wheels with a threaded nut are intended for use primarily on small and large right angle grinders. Featuring Weiler's individual knot hole construction, these radial brushes are available in heat-treated steel, Type 302 stainless steel and bronze wire for use in a wide variety of applications.

APPLICATIONS

- Removing powder-coating, epoxy-based paints, and rubberized coatings
- Weld preparation and cleaning
- Cleaning scale and heavy corrosion
- Removing heavy burrs from large pieces after cutting

P **STANDARD TWIST WHEELS** provide heavy-duty brushing action with some flexibility; ideal for deburring and demanding cleaning applications on somewhat irregular surfaces.

Dia.	Wire Size	Arbor Hole	No. of Knots	Face Width	Trim Length	Max. RPM	Std. Pack	Item Number	
								Steel	Stainless
3"	.014	3/8"-24 UNF	20	3/8"	5/8"	25,000	5	13201	13208 •
4"	.014	M10 x 1.50	24	1/2"	7/8"	20,000	5	–	13108 •
		3/8"-24 UNF						13110	
		1/2"-13 UNC						–	
		5/8"-11 UNC						13113 P V	
4"	.020	3/8"-24 UNF	24	1/2"	7/8"	20,000	5	13103	–
		5/8"-11 UNC						13105	–
6"	.016	5/8"-11 UNC	24	1/2"	1-3/8"	9,000	5	13106 P V	13113 P
	.023							–	–
								13117	–
								13120 V ▲	–
								–	08346
								08106	–

BOLD BLACK ITEM numbers indicate color-coded brushes for easy identification.
▲ Available in non-sparking bronze wire, see page 102-103 for details.

P V Display Packed & Vending Ready product available, add P or V to the end of item number when placing order.

V **WOLVERINE® STANDARD TWIST WHEELS** provide an aggressive brushing action for general purpose deburring, cleaning, and surface preparation applications.

Dia.	Wire Size	Arbor Hole	No. of Knots	Face Width	Trim Length	Max. RPM	Std. Pack	Item Number	
								Steel	Stainless
4"	.014	5/8"-11 UNC	20	1/2"	7/8"	20,000	5	36212	36213
6"	.025	5/8"-11 UNC	24	3/4"	1-1/4"	11,000	10	36224	–

P **CABLE TWIST WHEELS** provide maximum brushing action with minimal flexibility; ideal for demanding cleaning and surface preparation applications on relatively smooth surfaces.

Dia.	Wire Size	Arbor Hole	No. of Knots	Face Width	Trim Length	Max. RPM	Std. Pack	Item Number	
								Steel	Stainless
4"	.020	5/8"-11 UNC	24	1/4"	7/8"	20,000	5	13266 P V	13276

P V Display Packed & Vending Ready product available, add P or V to the end of item number when placing order.
BOLD BLACK ITEM numbers indicate color-coded brushes for easy identification.

V **WOLVERINE CABLE TWIST WHEELS** provide the most aggressive brushing action for general purpose cleaning and surface preparation applications.

Dia.	Wire Size	Arbor Hole	No. of Knots	Face Width	Trim Length	Max. RPM	Std. Pack	Item Number
								Steel
4"	.020	5/8"-11 UNC	20	1/4"	7/8"	20,000	5	36255



13113



08106

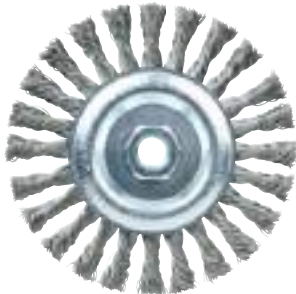

36224

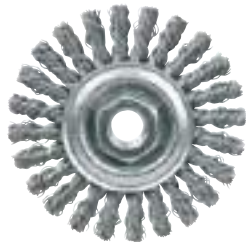

13266



36255

P **STANDARD TWIST BEVEL BRUSHES** are saucer-shaped radial wheels that provide a heavy-duty brushing action with some flexibility; ideal for cleaning fillet welds and into corners.



Diameter	Wire Size	Arbor Hole	No. of Knots	Face Width	Trim Length	Max. RPM	Std. Pack	Item Number	
								Steel	Stainless
4"	.014	5/8"-11 UNC	20	3/8"	3/4"	12,500	1	13406	13416
4"	.020	M14 x 2.0	20	3/8"	3/4"	12,500	1	13423	—
		5/8"-11 UNC						13426	13436
4-1/2"	.014	5/8"-11 UNC	20	3/8"	1"	12,500	1	13456	13466
4-1/2"	.020	5/8"-11 UNC	20	3/8"	1"	12,500	1	13476	13486

BOLD BLACK ITEM numbers indicate color-coded brushes for easy identification.

• Non-stock product, contact Customer Service for lead times and minimum order quantities.



13456

P **THREADED ADAPTERS** for mounting brushes with a 5/8"-11 UNC nut to other threaded spindles.

Fixed Thread Size	Adapted Thread Size	Standard Pack	Item Number
5/8"-11 UNC	M10 x 1.50	10	07772
5/8"-11 UNC	3/8"-16 UNC	10	07769
5/8"-11 UNC	3/8"-24 UNF	10	07746



07772

KNOT WIRE WHEELS WITH STEM

MADE IN USA
WITH GLOBAL MATERIALS

Knot wire wheels with a permanently attached 1/4" stem or shank are primarily intended for use on high-speed die grinders. Although they can also be mounted onto a drill, the speed and power of that tool will limit the effectiveness of the brush. Featuring Weiler's individual knot hole construction, these radial wheels are available in heat-treated steel and Type 302 stainless steel wire.

APPLICATIONS

- Removing powder-coating, epoxy-based paints, and rubberized coatings
- Weld preparation and cleaning
- Cleaning scale and heavy corrosion
- Removing heavy burrs from large pieces after cutting

P **STANDARD TWIST WHEELS 1/4" Stem** - Provide heavy-duty brushing action with some flexibility; ideal for deburring and demanding cleaning applications on somewhat irregular surfaces.



Diameter	Wire Size	No. of Knots	Face Width	Trim Length	Max. RPM	Standard Pack	Item Number	
							Steel	Stainless
3-1/4"	.0118	20	3/8"	5/8"	25,000	5	17680	—
	.014						17681	17684
	.020						17682	—
4"	.0118	24	1/2"	7/8"	20,000	5	17686	—
	.014						17687	17691
	.020						17689	—

P V Display Packed & Vending Ready product available, add P or V to the end of item number when placing order.

BOLD BLACK ITEM numbers indicate color-coded brushes for easy identification.



17684

"We get a competitive edge with Weiler because their prices are competitive but they last far longer."

- Jim Martin, Vice President, Karnel Incorporated



Key:

P Performance line
Industrial Grade

V Value line
Professional Grade

WHY WEILER
BONDED ABRASIVES
COATED ABRASIVES
NON-WOVEN ABRASIVES
POWER BRUSHES
NYLON BRUSHES
PACKAGED ITEMS
MAINTENANCE

WELD CLEANING BRUSHES

Weiler's stringer bead wheels are the most effective weld cleaning tools for the most demanding users. Our premium weld cleaning brushes are manufactured to the most stringent quality standards, utilizing the highest quality wire available. The twist puts all the sharp tips at the end of the knots, making them the fastest, most aggressive weld cleaning tools on the market.



UP TO
2X
THE LIFE



ROUGHNECK MAX

MADE IN
USA
WITH GLOBAL
MATERIALS

Roughneck Max wheels have been re-engineered to MAXimize life, efficiency and consistency. But that is only a small part of what makes this brush better...

- **Smooth & Responsive** — Improved feel and comfort during use makes brush operation effortless
- **No Long Wire Breakage** — Stronger, sharper wire delivers consistency and performance you can count on
- **Cleans 40% Faster** — Unmatched cleaning power compared to competitors
- **Less Force Required** — The operator can apply less pressure to clean, letting the wire do the work

P **ROUGHNECK® MAX STRINGER BEAD WHEELS** deliver unmatched weld cleaning performance by maximizing life, efficiency and consistency. The 4" brushes are recommended for cleaning root pass welds, surface prep and other cleaning applications.

Diameter	Wire Size	Arbor Hole	No. of Knots	Face Width	Trim Length	Thickness at Face Plates	Max. RPM	Std. Pack	Item Number	
									Steel	Stainless
4"	.020	5/8"-11 UNC	32	3/16"	7/8"	7/16"	20,000	5	13131 PV	13138 P

P V Display Packed & Vending Ready product available, add P or V to the end of item number when placing order.
BOLD BLACK ITEM numbers indicate color-coded brushes for easy identification.



13138



13124

ROUGHNECK

MADE IN
USA
WITH GLOBAL
MATERIALS

P **ROUGHNECK STRINGER BEAD WHEELS** are the standard for high-performance weld cleaning brushes. Narrow face brushes are suitable for cleaning root and hot passes and reaching into corners; wider face wheels can be used for cleaning filler and cap passes as well as for other surface prep and cleaning applications.

Diameter	Wire Size	Arbor Hole	No. of Knots	Face Width	Trim Length	Thickness at Face Plates	Max. RPM	Std. Pack	Item Number		
									Steel	Stainless	
Root Pass Brushes											
4"	.020	1/2"-3/8" M10 x 1.25 M14 x 2.0 3/8"-24 UNF 1/2"-13 UNC	32	3/16"	7/8"	7/16"	20,000	5	13124	08954*	
									13125	13132	
									13127	13134 •	
									13128	13135	
									13130	—	
4-1/2"	.020	5/8"-11 UNC 7/8"	38	3/16"	13/16"	3/8"	15,000	5	13232 V	13238	
5"	.020	5/8"-11 UNC 7/8"	38	3/16"	7/8"	3/8"	12,500	5	08756 V	08806 V	
6"	.020	5/8"-11 UNC	48	3/16"	1-1/8"	3/8"	12,500	10	08766†	—	
			38		1-3/8"				3/8"	—	08786†•
			56		1-1/8"				7/16"	09400 P	09500
7"	.020	5/8"-11 UNC	56	3/16"	1-1/8"	7/16"	9,000	10	09000 P	09200	
			76						—	09100	—
Filler Pass Brushes											
5"	.023	5/8"-11 UNC	24	1/2"	7/8"	3/8"	12,500	5	09856	09866	
6"	.023	5/8"-1/2"	24	1/2"	1-3/8"	9/16"	12,500	10	08775	—	
		5/8"-11 UNC	24		1-3/8"	9/16"			08776	08796•	
		5/8"-11 UNC	30		1-1/4"	5/8"			08916	08926•	



09000

08776

NOTE

If a different arbor hole is required (than listed in the tables) refer to Threaded Adapter Chart shown on Pg. 71.

P V Display Packed & Vending Ready product available, add P or V to the end of item number when placing order. † Light Duty • Standard Pack 5 * Standard Pack 10
BOLD BLACK ITEM numbers indicate color-coded brushes for easy identification.

THE DUALLY®



MADE IN USA
WITH GLOBAL MATERIALS

- **Maximum Cleaning Action** — Featuring a knot twist with the most aggressive cutting action, the new dual-hex nut makes it easier for the user to regularly switch mounting position and keep the brush running at peak performance.
- **Long Wheel Life** — Utilizing the highest quality heat-treated Steel wire and construction that virtually eliminates knot movement, the Dually delivers smooth operation and long life for the lowest cleaning costs in demanding multi-pass welding applications such as pipeline construction.
- **Improved User Safety** — The one-piece, dual-hex nut is designed to provide adequate tool clearance so there is no need to remove the guard from the grinder in order to change the position of the wheel.



Removing weld slag before the next weld pass.

P DUALLY® STRINGER BEAD WHEELS feature a dual-hex nut design that simplifies periodic flipping of the wheel for maximum cleaning action, long life, and safer use.

Diameter	Wire Size	Arbor Hole	No. of Knots	Face Width	Trim Length	Thickness at Face Plates	Max. RPM	Standard Pack	Item Number	
									Steel	Stainless
Root Pass Brushes										
4-1/2"	.020	5/8"-11 UNC	38	3/16"	13/16"	3/8"	15,000	5	79801	79811
5"	.020	5/8"-11 UNC	38	3/16"	7/8"	3/8"	12,500	5	79802	—
6"	.020	5/8"-11 UNC	56	3/16"	1-1/8"	7/16"	12,500	5	79805	—
7"	.020	5/8"-11 UNC	56	3/16"	1-1/8"	7/16"	9,000	5	79800	79810
Filler Pass Brushes										
5"	.023	5/8"-11 UNC	24	1/2"	7/8"	3/8"	12,500	5	79803	—
6"	.023	5/8"-11 UNC	30	1/2"	1-1/4"	5/8"	12,500	5	79804	—



79802

P POLYFLEX™ ENCAPSULATED WELD CLEANING WHEELS Black Elastomer*

Feature a heat-stabilized encapsulation that gradually wears away to expose a consistent short trim for higher aggression, controlled brushing action, and longer life; suitable for cleaning hot welds.

Diameter	Wire Size	Arbor Hole	No. of Knots	Face Width	Trim Length	Thickness at Face Plates	Max. RPM	Standard Pack	Item Number	
									Steel	Stainless
4"	.020	5/8"-11 UNC	32	3/16"	7/8"	7/16"	20,000	5	35800	▲
6"	.014	5/8"-11 UNC	—	3/16"	1-7/16"	3/8"	9,000	5	35206	◆
7"	.020	5/8"-11 UNC	56	3/16"	1-1/8"	7/16"	9,000	10	35600	▲
	.014		—		1-15/16"				3/8"	5

* See Elastomer Color Code Chart on page 61 for more information. ▲ Stringer Bead Wheels ◆ Crimped wire



35800



35216

WOLVERINE®

Wolverine wheels offer professional grade quality and performance at a great value. Re-engineered, these 32 knot wheels deliver 20% MORE life while maintaining aggressive cleaning power for weld cleaning applications.

MADE IN USA
WITH GLOBAL MATERIALS

V WOLVERINE® STRINGER BEAD WHEELS have upgraded to 32 knots to deliver 20% longer life.

The 4" wheels are manufactured using similar product construction and to the same exacting standards as other Weiler weld cleaning brushes; they have been engineered for cost-effective use in less demanding cleaning applications.

Diameter	Wire Size	Arbor Hole	No. of Knots	Face Width	Trim Length	Thickness at Face Plates	Max. RPM	Standard Pack	Item Number	
									Steel	Stainless
4"	.020	5/8"-11 UNC	32	3/16"	7/8"	7/16"	20,000	5	36218	36219

BOLD BLACK ITEM numbers indicate color-coded brushes for easy identification.



36219

V WOLVERINE STRINGER BEAD WHEELS are manufactured using similar product construction and to the same exacting standards as other Weiler weld cleaning brushes; they have been engineered for cost-effective use in less demanding applications.

Dia.	Wire Size	Arbor Hole	No. of Knots	Face Width	Trim Length	Max. RPM	Standard Pack	Item Number	
								Steel	Stainless
5"	.020	5/8"-11 UNC	38	3/16"	7/8"	12,500	5	36295	36296
6"	.020	5/8"-11 UNC	48	1/4"	1-1/4"	12,500	10	36225	—
			38	3/16"	1-3/8"			36307†	—
7"	.020	5/8"-11 UNC	56	3/16"	1-1/8"	9,000	10	36297	—

† Light Duty

• Non-stock product, contact Customer Service for lead times and minimum order quantities.

36297



CRIMPED WIRE WHEELS WITH ARBOR HOLE

MADE IN
USA
WITH GLOBAL
MATERIALS



Removing heat discoloration from a stainless steel canister.

Crimped Wire Wheels with Arbor Hole are intended for use on straight grinders and stationary machines such as bench or pedestal grinders and buffing lathes. Featuring Weiler's solid ring construction, these radial brushes are available in heat-treated steel, Type 302 stainless steel and brass wire for use in a wide variety of applications.

APPLICATIONS

- Removing rust and light corrosion
- Paint removal and surface cleaning
- Decorative finishing
- Removing heat discoloration
- Light deburring



P **CRIMPED WIRE WHEELS - Narrow Face** - provide a flexible brushing action and consistent performance for demanding light-duty cleaning and deburring applications.

Dia.	Wire Size	Arbor Hole	Face Width	Trim Length	Max. AH Avail.	Thickness at Face Plates	Max. RPM	Std. Pack	Item Number		
									Steel	Stainless	
3"	.006	1/2"-3/8"	7/16"	1/2"	3/4"	7/16"	12,500	2	00204 •	—	
	.008								00214	—	
	.0118								00234	00264 •	
	.014								00274	—	
4"	.006	1/2"-3/8"	1/2"	7/8"	3/4"	7/16"	12,500	2	00104	00154	
	.006								5/8"-1/2"	—	
	.008	1/2"-3/8"							—		
	.0118	—							00114	—	
	.0118	5/8"-1/2"							00134	00184	
	.014	1/2"-3/8"							00135	—	
6"	.006	5/8"-1/2"	3/4"	1-7/16"	1-1/4"	7/16"	6,000	10	01035 ▲	01675*	
	.008								—		
	.008	1-1/4" ★							—		
	.0104	5/8"-1/2"							01055	01695*	
	.0118	—							01065 ▲	01705*	
	.014	—							01075 P	—	
6"	.0118	3/4"	3/4"	1-7/16"	1-1/4"	7/16"	6,000	10	01068	—	
8"	.006	5/8"	3/4"	2-1/16"	1-1/4"	1/2"	6,000	2	01135	01775	
	.008								—		
	.0104								01155	01795	
	.0118								01165	01805	
	.014								01175 P	—	
8"	.006	3/4"	3/4"	2-1/16"	1-1/4"	1/2"	6,000	2	01138	—	
	.008								01148	—	
	.0104								01158	—	
	.0118								01168	—	
	.014								01178	—	
	.0118								1-1/4" ★	3/4"	2-1/16"
.014	—	—	—	—	—	—	—	01179	—		
10"	.006	3/4"	3/4"	2-1/2"	2"	5/8"	4,000	2	01228 •	—	
	.0104								01238	—	
	.0118								01248	—	
	.014								01258	01898	
	.014								1"	01250-12	—
	.014								1-1/4" ★	3/4"	2-1/2"
12"	.006	1-1/4" ★	3/4"	2-15/16"	2-1/2"	1/2"	3,000	2	01299	01939 •	
	.0104								01309 •	01949 •	
	.0118								01319	—	
	.014								01329	—	
12"	.014	2" ◆	3/4"	2-15/16"	2-1/2"	1/2"	3,000	2	01320-14 •	—	
15"	.0118	1-1/4" ★	3/4"	4-7/16"	2-1/2"	1/2"	3,000	2	01339 •	—	
	.014								01349	—	

NOTE

If a different arbor hole is required (than listed in the tables) refer to Arbor Hole Table shown on Pg. 61.

◆ 1/2" x 1/4" Double Keyway ★ 5/16" x 5/32" Double Keyway • 1/4" x 1/8" Double Keyway * Standard Pack 2
 P V Display Packed & Vending Ready product available, add P or V to the end of item number when placing order.
 ▲ Available in non-sparking brass wire, see page 102-103 for details.

• Non-stock product, contact Customer Service for lead times and minimum order quantities.



V WOLVERINE® CRIMPED WIRE WHEELS - Narrow Face - provide a flexible brushing action and cost-effective performance in general purpose cleaning and deburring applications.

Dia.	Wire Size	Arbor Hole	Face Width	Trim Length	Max. AH Avail.	Max.RPM	Std. Pack	Item Number	
								Steel	Stainless
4"	.014	1/2"-3/8"	1/2"	3/4"	1/2"	6,000	2	36262	—
6"	.014	5/8"-1/2"	3/4"	1-1/4"	5/8"	6,000	10	—	36201 •
8"	.014	5/8"	3/4"	2"	5/8"	6,000	2	36205	—

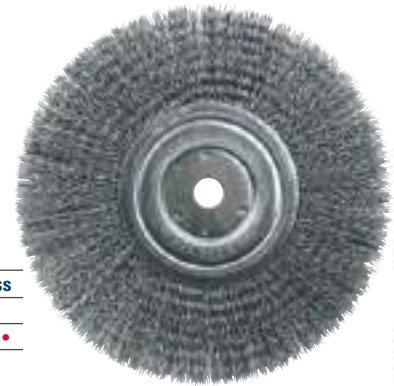

36205



P POLYFLEX™ ENCAPSULATED CRIMPED WIRE WHEELS feature an encapsulation that gradually wears away to expose a consistent short trim for higher aggression, controlled brushing action, and longer life.

Dia.	Wire Size	Arbor Hole	Face Width	Trim Length	Max. AH Avail.	Thickness at Face Plates	Max. RPM	Standard Pack	Item Number Steel
Burgundy Elastomer* - Standard									
6"	.0104	5/8"-1/2"	1/2"	1-7/16"	1-1/4"	7/16"	6,000	2	35105
8"	.014	5/8"	1/2"	2-1/16"	1-1/2"	1/2"	6,000	2	35135

* See Elastomer Color Code chart on page 61 for more information.



35105



P BENCH GRINDER WHEELS feature a shorter trim length, narrower face width, and the same durable construction as other Weiler crimped wire wheels; designed specifically for use on small bench grinders for reduced flaring and long life in a broad range of applications.

Dia.	Wire Size	Arbor Hole	Face Width	Trim Length	Max. AH Avail.	Thickness at Face Plates	Max. RPM	Standard Pack	Item Number Steel
6"	.006	5/8"-1/2"	1/2"	1-1/16"	1-1/4"	7/16"	6,000	10	01085
	.008								01095
	.0118								01115
	.014								01125



01115



P CRIMPED WIRE WHEELS - High Density - Feature an increased fill density for greater brushing action, more consistent performance, and longer life in the most demanding applications requiring the flexibility of a crimped wire wheel.

Dia.	Wire Size	Arbor Hole	Face Width	Trim Length	Max. AH Avail.	Thickness at Face Plates	Max. RPM	Std. Pack	Item Number	
									Steel	Stainless
4-1/4"	.014	5/8"-1/2"	3/4"	5/8"	3/4"	9/16"	6,000	1	01502 •	—
6"	.0118	5/8"-1/2"	3/4"	1-1/8"	1"	9/16"	6,000	1	—	01508 •
	.014								01505 •	
	.020								01506 •	
7"	.014	5/8"	7/8"	1-5/8"	1"	9/16"	6,000	1	01511	—
8"	.0118	5/8"	7/8"	1-1/2"	1-1/4"	11/16"	4,500	1	01514	—
	.014								01515	—



01502



01515

• Non-stock product, contact Customer Service for lead times and minimum order quantities.

WHY WEILER

BONDED ABRASIVES

COATED ABRASIVES

NON-WOVEN ABRASIVES

POWER BRUSHES

NYLON BRUSHES

PACKAGED ITEMS



06020



06040

P

CRIMPED WIRE WHEELS - Medium Face - Provide a flexible brushing action and consistent performance for demanding light-duty cleaning and deburring applications; feature a wider face width to cover more area.

Dia.	Wire Size	Arbor Hole	Face Width	Trim Length	Thickness at Face Plates	Max. RPM	Standard Pack	Item Number	
								Steel	Stainless
4-1/2"	.0118	2"	15/16"	3/4"	7/8"	6,000	1	06020	—
6"	.006	2"	1"	1-1/8"	15/16"	6,000	1	06040	—
	.008							06050	—
	.0104							06060	06440
	.0118							06070	06450
	.014							06080	—
8"	.006	2"	1"	1-3/8"	1"	4,500	1	06090	—
	.0104							06100	—
	.0118							06110	06490
	.014							06120	—
	.020							06620	—
10"	.0118	2"◆	1-1/8"	2"	1"	3,600	1	06150	06530
	.014							06160	—
	.020							06170	—
12"	.0118	2"◆	1-1/4"	3"	1"	3,600	1	06180	—
	.014							06190	—
	.020							06200	—

◆ 1/2" x 1/4" Double Keyway
For arbor hole reducing adapters, see Metal Adapter Table below.



02335

V

WOLVERINE® CRIMPED WIRE WHEELS - Medium Face - Provide a flexible brushing action and cost-effective performance in general purpose cleaning and deburring applications; feature a wider face width to cover more area.

Dia.	Wire Size	Arbor Hole	Face Width	Trim Length	Thickness at Face Plates	Max. RPM	Standard Pack	Item Number	
								Steel	Stainless
6"	.014	5/8"-1/2"	5/8"	1-1/16"	1/2"	6,000	1	02325	—
			3/4"	1-7/16"	7/16"			36203	—
7"	.014	5/8"	3/4"	1-9/16"	1/2"	6,000	1	02335	—

P

METAL ADAPTERS for Medium & Wide Face Brushes. Used in pairs & priced per pair.

For Brush Arbor Hole Size	Adapted Arbor Hole Size	Item Number
2"	1/2"	03809
	5/8"	03810
	3/4"	03811
	7/8"	03824
	1"	03812
	1-1/4"	03813
	1-1/2"	03814



03809



22061

P

PLATER'S WIRE WHEELS feature a longer trim length and very small diameter fill material for producing fine satin and antique finishes on non-ferrous and precious metals.

Dia.	Wire Size	Arbor Hole	Face Width	Trim Length	Number of Rows	Max. RPM	Std. Pack	Item Number	
								Brass*	Stainless
4"	.004	1/4"	1"	1-1/4"	4	4,000	5	22061	—

* Non-stock product, contact Customer Service for lead times and minimum order quantities.



P

CRIMPED WIRE WHEELS - Wide Face - Provide a flexible brushing action and consistent performance for demanding light-duty cleaning and deburring applications; feature a wider face width to cover more area.

Dia.	Wire Size	Arbor Hole	Face Width	Trim Length	Thickness at Face Plates	Max. RPM	Standard Pack	Item Number	
								Steel	Stainless
4-1/2"	.006	2"	1-1/4"	3/4"	7/8"	6,000	1	03000 •	—
	.0118							03010 •	—
	.014							03020 •	—
6"	.006	2"	1-1/4"	1-1/8"	1"	6,000	1	03030 •	03480
	.0118							03060	03510
	.014							03070	03520
7"	.0118	2"	1-1/4"	1-5/8"	1"	6,000	1	03090	—
	.014							03100	—
8"	.006	2"	1-1/2"	1-3/8"	1-3/8"	4,500	1	03110	—
	.0118							03140	03590 •
	.014							03150	—
	.020							03160	—
10"	.0104	2"	2"	1-7/8"	1-5/8"	4,000	1	03180	—
	.0118							03190	—
	.014							03200	—
	.020							03210	—
12"	.0118	2"	2"	2-7/8"	1-9/16"	3,000	1	03220	—
	.014							03230	03680
	.020								

For arbor hole reducing adapters, see Metal Adapter Table on page 76.



03000



03110

WHY WEILER

BONDED ABRASIVES

COATED ABRASIVES

NON-WOVEN ABRASIVES

V

WOLVERINE® CRIMPED WIRE WHEELS - Wide Face - Provide a flexible brushing action and cost-effective performance in general purpose cleaning and deburring applications; feature a wider face width to cover more area.

Dia.	Wire Size	Arbor Hole	Face Width	Trim Length	Thickness at Face Plates	Max. RPM	Standard Pack	Item Number
								Steel
6"	.014	2"-5/8"-1/2"	7/8"	1-1/8"	7/8"	6,000	1	06645
7"	.014	2"-5/8"	7/8"	1-5/8"	7/8"	6,000	1	06655
8"	.014	2"-5/8"	1"	1-3/8"	1"	4,000	1	36206



06645

POWER BRUSHES

NYLON BRUSHES



P

POLYFLEX™ ENCAPSULATED CRIMPED WIRE WHEEL - Wide Face - Burgundy*

Elastomer* - Features an encapsulation that gradually wears away to expose a consistent short trim for higher aggression, controlled brushing action, and longer life. Wider face width covers more area.

Dia.	Wire Size	Arbor Hole	Face Width	Trim Length	Thickness at Face Plates	Max. RPM	Std. Pack	Item Number
								Steel
6"	.0118	2"	1"	1-1/8"	1"	6,000	1	35160

* See Elastomer Color Code Chart on page 61 for more information.
For arbor hole reducing adapters, see Metal Adapter Table on page 76.



35160

PACKAGED ITEMS

MAINTENANCE

• Non-stock product, contact Customer Service for lead times and minimum order quantities.

SMALL DIAMETER "COPPER CENTER" WHEELS

MADE IN
USA
WITH GLOBAL
MATERIALS



Removing casting flash from ductile-iron housing with an encapsulated brush.

Weiler's small diameter crimped wire wheels feature a plain arbor hole for use on a variety of portable tools and stationary machines. Featuring Weiler's solid ring construction for high-speed use, these radial brushes are available in heat-treated steel, Type 302 stainless steel, and brass wire.

APPLICATIONS

- Removing carbon build-up and deposits
- Removing rust and light corrosion
- Cleaning and finishing ID's and recessed areas
- Cleaning boiler tubes and internal passages
- Cleaning threads
- Wire stripping
- Light deburring



P **SMALL DIAMETER WHEELS** provide a flexible brushing action and consistent performance for light-duty cleaning and deburring applications requiring a small wheel.

-	Wire Size	Arbor Hole	Face Width	Trim Length	Max. RPM	Standard Pack	Item Number		
							Steel	Stainless	
1"	.003	1/4"	3/16"	1/4"	20,000	10	-	16461	
	.005						-	16471	
	.006						15071	-	
1-1/4"	.003	1/4"	1/4"	3/8"	20,000	10	15101 ●	-	
	.006						15111	-	
	.008						-	16521	
1-3/8"	.008	3/8"	1/4"	5/16"	20,000	10	15732 ●	-	
	.006						15131	-	
	.0104						15141	-	
1-1/2"	.006	3/8"	1/4"	7/16"	20,000	10	15302 ▲	-	
	.008						15312	16712	
	.0104						15322	-	
	.0118						15332	-	
	.014						15762	-	
2"	.003	1/2"-3/8"	3/8"	3/4"	20,000	10	99307	-	
	.006						-	16833	
	.006						15433 ▲	-	
	.008						15443	16843	
	.0104						-	16853	
	.0118						15463 ▲	-	
	.014						15473	16873	
2-1/2"	.0118	1/2"-3/8"	1/2"	3/4"	20,000	10	15513	-	
	.014						15523	-	
3"	.003	1/2"-3/8"	5/8"	1"	20,000	10	99551	-	
	.006						15533	16933	
	.006						-	15637	
	.006						15/16"	-	
	.008						1"	15543	16943
	.008						5/8"	15647 ●	-
	.0104						1"	15553	-
	.0118						1"	15563	16963
	.0118						5/8"	15667 ●	-
	.014						1/2"-3/8"	15573 ▲	16973
4"	.014	5/8"	1/2"	1-1/2"	20,000	10	15677	-	
	.006						99553	-	

▲ Available in non-sparking brass wire, see page 102-103 for details.

● Non-stock product, contact Customer Service for lead times and minimum order quantities.



15071

15111

16712

15433

15563

99553

P POLYFLEX™ ENCAPSULATED SMALL DIAMETER WHEELS -

Burgundy Elastomer* - Feature an encapsulation that gradually wears away to expose a consistent short trim for higher aggression, controlled brushing action, and longer life.

Diameter	Wire Size	Arbor Hole	Face Width	Trim Length	Max. RPM	Standard Pack	Item Number
							Steel
2"	.0104	1/2"	1/4"	1/2"	20,000	10	35240
	.014						35070
3"	.0118	1/2"	1/4"	1"	20,000	10	35250
	.014						35260

* See Elastomer Color Code chart on page 61 for more information.



WIRE STRIPPING BRUSHES

Used for removing insulation from electrical wire. These brushes are made to order according to the specifications needed for the specific application.

When ordering, please specify:

- Brush diameter
- Arbor hole size
- Brush face width
- Wire size

For application assistance, contact a specialist at: 800-835-9999.



NOTE

- The adapters and drive arbors listed on this page are for use with small diameter wheel brushes only; do not attempt to use them with cutting or grinding wheels, buffing wheels, or any type of abrasive wheel or disc.
- Do not adapt a wheel brush for use on a shaft diameter less than that specified by ANSI B165.1 (see page 55) or exceed the maximum wheel diameter specified for a drive arbor.
- Never mount a drive arbor onto a tool that operates above the maximum RPM rating of either the arbor or the brush (whichever may be lower) and be sure that the stem of the arbor is properly secured in the collet or chuck before use.

P DRIVE ARBORS for mounting small diameter wheels into a collet or chuck.

Arbor Dia.	Stem Dia.	Stem Length	Length of Shaft	For Brushes with a Max. Dia. of	Overall Length	Max. RPM	Standard Pack	Item Number
Unthreaded Shaft								
1/4"	1/4"	1-1/8"	3/16"	2"	2-1/16"	20,000	5	07723
3/8"	1/4"	1-1/8"	3/16"	4"	1-15/16"	20,000	5	07722
Threaded Shaft								
1/4"	1/4"	1-1/16"	1-1/8"	2"	2-9/16"	20,000	5	07725
3/8"	1/4"	3/4"	3/4"	3"	1-9/16"	25,000	5	07727
3/8"	1/4"	1"	1-1/8"	3"	2-9/16"	20,000	5	07726
1/2"	1/4"	3/4"	3/4"	3"	1-3/4"	25,000	5	07724
1/2"	1/4"	7/8"	3/4"	3"	1-11/16"	20,000	5	07721
5/8"	1/4"	3/4"	3/4"	3"	1-13/16"	25,000	5	07729



P PLASTIC ADAPTERS for mounting small diameter wheels onto various arbor sizes.

Fixed Arbor Hole Size	Adapted Arbor Hole Size	Standard Pack	Item Number
1/2"	1/4"	10	04400
1/2"	3/8"	10	04401
5/8"	1/2"	10	04402



WHY WEILER BONDED ABRASIVES COATED ABRASIVES NON-WOVEN ABRASIVES POWER BRUSHES NYLON BRUSHES PACKAGED ITEMS MAINTENANCE

CRIMPED WIRE WHEELS WITH NUT OR STEM

MADE IN
USA
WITH GLOBAL
MATERIALS

Crimped wire wheels with a threaded nut are intended for use primarily on small angle grinders. Featuring Weiler's solid ring construction, these radial brushes are available in heat-treated steel and Type 302 stainless steel wire.

APPLICATIONS

- Removing rust and light corrosion
- Surface prep prior to welding
- Removing heat discoloration and welding residuals



Removing flash from a sand-cast iron engine block.

P **CRIMPED WIRE WHEELS** provide a flexible brushing action and consistent performance for demanding light-duty cleaning and deburring applications.



Dia.	Wire Size	Arbor Hole	Face Width	Trim Length	Max. RPM	Std. Pack	Item Number	
							Steel	Stainless
4"	.006	5/8"-11 UNC	1/2"	7/8"	14,000	5	—	00156
4"	.014	M14 x 2.0	1/2"	7/8"	14,000	5	13077 •	—
		3/8"-24 UNF					13078 •	—
		5/8"-11 UNC					13081	13085
4"	.014	5/8"-11 UNC	1/2"	7/8"	14,000	5	35416*	—

* Polyflex™ encapsulated - Burgundy elastomer. See Elastomer Color Code Chart on page 61 for more information.



13085



36207

V **WOLVERINE® CRIMPED WIRE WHEEL** provides a flexible brushing action and cost-effective performance in general purpose cleaning and deburring applications.



Diameter	Wire Size	Arbor Hole	Face Width	Trim Length	Max. RPM	Standard Pack	Item Number
							Steel
4"	.014	5/8"-11 UNC	1/2"	3/4"	14,000	5	36207



35416

Crimped wire wheels with a permanently attached 1/4" stem or shank are primarily intended for use on high-speed die grinders. Although they can also be mounted onto a drill, the speed and power of that tool will limit the effectiveness of the brush. Featuring Weiler's solid ring construction, these radial wheels are available in heat-treated steel, Type 302 stainless steel, and brass wire.

APPLICATIONS

- Cleaning and finishing ID's and recessed areas
- Paint removal and surface cleaning
- Cleaning threads
- Light deburring



P **CONFLEX BRUSHES** **Narrow Face - 1/4" Stem** - Provide a very flexible brushing action.

Diameter	Wire Size	Face Width	Trim Length	Max. RPM	Standard Pack	Item Number	
						Steel	Stainless
2"	.006	3/8"	1/2"	20,000	10	17609	—
	.0118					17610	17611
2-1/2"	.006	3/8"	3/4"	20,000	10	17612	—
	.014					17614	—
3"	.008	1/2"	1"	20,000	10	17615	—
	.0118					17616 V ▲	—
	.014					17617 P	17618 V

P **V** Display Packed & Vending Ready product available, add P or V to the end of item number when placing order.

▲ Available in non-sparking brass wire, see page 102-103 for details.

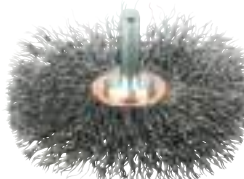

17616

P **POLYFLEX™ ENCAPSULATED CONFLEX BRUSHES - Burgundy Elastomer* - 1/4" Stem** - Feature an encapsulation that gradually wears away to expose a consistent short trim for higher aggression, controlled brushing action, and longer life.

Diameter	Wire Size	Face Width	Trim Length	Max. RPM	Standard Pack	Item Number
						Steel
2"	.0118	1/4"	1/2"	20,000	10	35305 •
3"	.008	1/4"	1"	20,000	10	35310
	.0118					35315

* See Elastomer Color Code Chart on page 61 for more information.

• Non-stock product, contact Customer Service for lead times and minimum order quantities.



35310

P **CONFLEX BRUSHES - Wide Face - 1/4" Stem** - Provide a flexible brushing action and consistent performance for demanding light-duty cleaning and deburring applications; feature a wider face width to cover more area.



Diameter	Wire Size	Face Width	Trim Length	Max. RPM	Standard Pack	Item Number	
						Steel	Stainless
1-1/4"	.006	1/2"	3/8"	20,000	10	17600	—
	.008					17601	—
	.0118					17602	—
1-1/2"	.006	1/2"	1/2"	20,000	10	17603	—
	.008					17604	—
	.0118					17605	—
1-3/4"	.006	1/2"	5/8"	20,000	10	—	17608
	.008					—	17608
2"	.0118	3/4"	7/16"	20,000	10	17619	—
2-1/2"	.014	3/4"	11/16"	20,000	10	17620	—
3"	.008	1"	15/16"	20,000	10	17621	17637
	.0118					17622	—
	.014					17623	—



17603

P **CRIMPED WIRE RADIAL WHEELS 1/4" Stem** - Feature side plates for a shorter trim length and more controlled brushing action in a stem-mounted crimped wire wheel.

Diameter	Wire Size	Face Width	Trim Length	Max. RPM	Standard Pack	Item Number	
						Steel	Stainless
1-1/2"	.006	1/4"	3/8"	20,000	10	17950	17971
	.008					17951	17972 •
	.0118					17952 •	17973
	.014					17953	—
	.020					17954	—
2"	.006	3/8"	7/16"	20,000	10	17955	17974
	.008					17956	—
	.0118					17957	17975
	.014					17958 •	—
	.020					17959	17976 •
2-1/2"	.008	7/16"	9/16"	20,000	10	17961	—
	.0118					17962	17977 •
	.014					17963 •	—
	.020					17964	17978
3"	.008	1/2"	13/16"	20,000	10	17965	—
	.0118					17966	17979
	.014					17967	—
	.020					17968	17981
4"	.008	9/16"	1-5/16"	15,000	10	17969	17982
	.014					17981	—
	.020					17982	—



17971



17978

V **WOLVERINE® CRIMPED WIRE RADIAL WHEELS 1/4" Stem** - Designed to be a flexible and economic small diameter brushing tool for a broad range of general purpose applications.



Diameter	Wire Size	Face Width	Trim Length	Max. RPM	Standard Pack	Item Number
						Steel
1-1/2"	.0118	1/4"	3/8"	20,000	10	36208*
	.014					36209*
3"	.008	7/16"	13/16"	20,000	10	36259*
	.014					36211*

* Globally sourced products



36211

P **CONCAVE BRUSHES 1/4" Stem** - Saucer-shaped radial wheels provide flexible brushing action for addressing corners and hard-to-reach areas.



Diameter	Wire Size	Face Width	Trim Length	Max. RPM	Standard Pack	Item Number	
						Steel	Stainless
1-1/2"	.006	1/4"	3/8"	20,000	10	17901	17930
	.008					17902	—
	.0118					17903	17931 •
2"	.008	3/8"	1/2"	20,000	10	17906	—
	.014					17907	17933
2-1/2"	.006	7/16"	5/8"	20,000	10	17909	—
	.014					17912	17935
3"	.006	1/2"	15/16"	20,000	10	17914	17936
	.008					17915	—
	.014					17917	17937
	.020					17922	—
4"	.008	9/16"	1-1/4"	20,000	10	17923	—
	.014					17923	—



17907

• Non-stock product, contact Customer Service for lead times and minimum order quantities.

WHY WEILER
BONDED ABRASIVES

COATED ABRASIVES

NON-WOVEN ABRASIVES

POWER BRUSHES

NYLON BRUSHES

PACKAGED ITEMS

MAINTENANCE

NYLON AND TAMPICO WHEELS

MADE IN USA
WITH GLOBAL MATERIALS



Deburring a plastic part using a nylon brush.

NYLON WHEELS

Wheel brushes filled with non-metallic filaments are primarily intended for light-duty surface cleaning and scrubbing applications as well as scratch-free finishing and polishing. Synthetic filaments such as nylon are durable and provide a very flexible brushing action in applications requiring less aggression than a wire brush. The softer fill material allows them to be used on materials that a wire brush would scratch or gouge.

APPLICATIONS

- Wet or dry cleaning and scrubbing
- Removing burrs and die flash from plastic parts
- Sweeping loose chips and debris

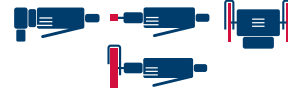

P **NYLON WHEELS** feature a chemical-resistant synthetic fill material with excellent bend recovery for use in applications requiring a soft, durable fill material.

Diameter	Fill Diameter	Arbor Hole	Face Width	Trim Length	Max. RPM	Standard Pack	Item Number
2"	.010 .014	1/2"	3/8"	1/2"	20,000	10	17223 17233
3"	.010 .016	1/2"	3/8"	1"	20,000	10	29070 17263
6"	.016	2"	3/4"	1-1/2"	6,000	2	20490

For arbor hole reducing adapters, see Metal Adapter Table below and plastic adapters on page 79.

TAMPICO WHEELS

MADE IN USA
WITH GLOBAL MATERIALS

Wheel brushes filled with non-metallic filaments are primarily intended for light-duty surface cleaning and scrubbing applications as well as scratch-free finishing and polishing. Natural vegetable fibers such as Tampico hold abrasive compounds well and can be used for deburring, edge blending, and polishing applications.

APPLICATIONS

- Wet or dry cleaning and scrubbing
- Buffing and polishing non-ferrous and precious metals
- Removing burrs and blending edges with abrasive compounds



P **TAMPICO WHEELS** feature a durable vegetable fiber fill material that is chemical and heat resistant and also holds abrasive compounds well.

Diameter	Arbor Hole	Face Width	Trim Length	Max. RPM	Standard Pack	Item Number
3"	1/2"	1/2"	1"	20,000	10	17453
6"	2"	5/8"	1-1/2"	6,000	10	20180
8"	2"	5/8"	2-1/2"	5,000	2	20190

For arbor hole reducing adapters, see Metal Adapter Table below and plastic adapters on page 79.

P **METAL ADAPTERS** for 6" & 8" Brushes. Used in pairs & priced per pair.



For Brush Arbor Hole Size	Adapted Arbor Hole Size	Standard Pack	Item Number
2"	1/2"	1 pair	03809
	5/8"	1 pair	03810
	3/4"	1 pair	03811
	7/8"	1 pair	03824
	1"	1 pair	03812
	1-1/4"	1 pair	03813
	1-1/2"	1 pair	03814

WIRE CUP BRUSHES

Cup brushes are for use on portable power tools for addressing larger surface areas more efficiently than a wheel brush. Cup brushes featuring a threaded nut are designed for smooth, efficient operation on angle grinders to make quick work of large jobs. Utility cup brushes featuring a permanently-attached 1/4" stem are more suitable for smaller jobs and are recommended for use on high-speed air tools for the most effective brushing action and longest life. Cup brushes are manufactured with individual knot hole and solid ring construction for high performance and long life.

APPLICATIONS

- Removal of slag from the edges of plasma or flame-cut plates
- Removing paint and coatings
- Cleaning rust, scale, and corrosion
- Deburring
- Weld prep and cleaning

CUP BRUSH SIZE SELECTION GUIDE

Brush Sizes	Angle Grinder Size
2-3/4" & 3"	4"
2-3/4", 3" & 3-1/2"	4-1/2"
2-3/4", 3" & 3-1/2"	5"
3-1/2" & 4"	6"
4", 5" & 6"	7"
4", 5" & 6"	9"

MADE IN
USA
WITH GLOBAL
MATERIALS



Knot wire cup brush removing heat discoloration.

P **KNOT WIRE CUP BRUSHES - Single Row** - Provide heavy-duty brushing action with some flexibility; ideal for demanding cleaning applications on relatively flat surfaces.

Diameter	Wire Size	Arbor Hole	Trim Length	Max. RPM	Standard Pack	Item Number							
						Steel	Stainless						
2-3/4"	.014	M10 x 1.25	1"	14,000	1	13015	-						
		M10 x 1.50				13016 •	-						
		M14 x 2.0				13020	-						
		3/8"-24 UNF				13021	-						
		5/8"-11 UNC				13025 PV	13009						
2-3/4"	.020	M10 x 1.25	1"	14,000	1	13281	13253						
		M10 x 1.50				13282	13254 •						
		M14 x 2.0				13283	13255						
		3/8"-24 UNF				13284	13256						
		1/2"-13 UNC				13285	13257						
		5/8"-11 UNC				13286 ▲ PV	13258 V						
3-1/2"	.023	M10 x 1.25	7/8"	13,300	1	13150	-						
		M14 x 2.0				13152	-						
		3/8"-24 UNF				13153	13160						
		1/2"-13 UNC				13155	-						
		5/8"-11 UNC				13156 PV	13163 V						
3-1/2"	.014	5/8"-11 UNC	1-1/4"	9,000	1	12736	-						
						.020	12746	-					
						.014	12306 ▲	12406					
4"	.014	5/8"-11 UNC	1-1/4"	10,200	1	12316 PV	12416						
						.023	12326	-					
						.035	12206 ❖	-					
4"	.023	5/8"-11 UNC	1-1/4"	10,200	1	12826*	-						
						5"	.014	5/8"-11 UNC	1-3/8"	7,000	1	12256*	-
												.023	12276 V *
6"	.014	5/8"-11 UNC	1-3/8"	6,600	1	12356 V	12456						
						.023	12376 PV	12476					
						.035	12396	-					
6"	.023	5/8"-11 UNC	1-3/8"	6,600	1	12816*	-						
						6"	.014	5/8"-11 UNC	1-5/8"	6,000	1	12846	-
												.023	12856
	.035						12866	-					

▲ Available in non-sparking bronze wire, see page 102-103 for details.

* With internal nut ❖ Cable Twist

BOLD BLACK ITEM numbers indicate color-coded brushes for easy identification.

P V Display Packed & Vending Ready product available, add P or V to the end of item number when placing order.



13021



13258



12316



12276



13711

NOTE

If a different arbor hole is required (than listed in the tables) refer to Threaded Adapter Chart shown on Pg. 71.

• Non-stock product, contact Customer Service for lead times and minimum order quantities.

P **KNOT WIRE CUP BRUSHES - Hurricane Twist** - Very smooth brushing action and extended life with reduced cleaning action.

Diameter	Wire Size	Arbor Hole	Trim Length	Max. RPM	Standard Pack	Item Number
						Steel
2-3/4"	.014	M14 x 2.0	3/4"	14,000	1	13717 •
		5/8"-11 UNC				13718
2-3/4"	.020	M14 x 2.0	3/4"	14,000	1	13711 •
		5/8"-11 UNC				13712

COATED ABRASIVES

NON-WOVEN ABRASIVES

POWER BRUSHES

NYLON BRUSHES

PACKAGED ITEMS

MAINTENANCE



V WOLVERINE® KNOT WIRE CUP BRUSHES - Single Row

Provide an aggressive brushing action for general-purpose surface cleaning applications.



Dia.	Wire Size	Arbor Hole	Trim Length	Max. RPM	Standard Pack	Item Number	
						Steel	Stainless
3"	.020	5/8"-11 UNC	1"	14,000	1	36238	36239
4"	.025	5/8"-11 UNC	1-1/4"	9,000	1	36244	—
6"	.025	5/8"-11 UNC	1-3/8"	6,600	1	36245	—



P KNOT WIRE CUP BRUSHES - Banded - Single Row - Feature a removable metal band around fill material to reduce the exposed trim length and limit brush flaring at operating speed to provide a very aggressive, controlled brushing action.

Diameter	Wire Size	Arbor Hole	Trim Length	Max. RPM	Standard Pack	Item Number	
						Steel	Stainless
2-3/4"	.014	5/8"-11 UNC	5/8"	12,500	1	13300	—
	.020					13301	13302
4"	.023	5/8"-11 UNC	7/8"	10,200	1	12301	—
5"	.023	5/8"-11 UNC	7/8"	6,600	1	12120	—



P KNOT WIRE CUP BRUSH - 1-1/2 Rows - Features an internal nut for use on dedicated equipment such as line traveling machines that clean and prep OD of pipe prior to coating.

Diameter	Wire Size	Arbor Hole	Trim Length	Max. RPM	Standard Pack	Item Number	
						Steel	Stainless
4"	.023	5/8"-11 UNC	1-1/4"	7,000	1	94012	—



P KNOT WIRE CUP BRUSHES - Double Row - Provide very aggressive brushing while still maintaining some flexibility; ideal for severe cleaning applications.

Diameter	Wire Size	Arbor Hole	Trim Length	Max. RPM	Standard Pack	Item Number	
						Steel	Stainless
4"	.014	5/8"-11 UNC	1-1/4"	9,000	1	12756	—
	.020					12766	12726
6"	.014	5/8"-11 UNC	1-3/8"	6,600	1	12536	—
	.023					12556	12636
	.035					12576	—
6"	.014	5/8"-11 UNC	1-1/2"	6,000	1	12906	—
	.023					12916	—
	.035					12926	—



P KNOT WIRE CUP BRUSHES - Banded - Double Row - Feature a removable metal band around fill material to reduce the exposed trim length and limit brush flaring to provide an extremely aggressive, controlled brushing action for the most severe applications.

Diameter	Wire Size	Arbor Hole	Trim Length	Max. RPM	Standard Pack	Item Number	
						Steel	Stainless
4"	.020	5/8"-11 UNC	7/8"	9,000	1	12796	—
6"	.023	5/8"-11 UNC	7/8"	6,600	1	12676	—
	.035					12686	—



P POLYFLEX™ ENCAPSULATED CRIMPED WIRE CUP BRUSHES feature fill material that has been encapsulated in an elastomer that gradually wears away to keep only the wire tips exposed; ideal for applications on flat surfaces that require maximum aggression but no flexibility in the brushing action.

Diameter	Wire Size	Arbor Hole	Trim Length	Max. RPM	Standard Pack	Item Number	
						Steel	Stainless
Burgundy Elastomer* - Standard							
3-1/2"	.014	5/8"-11 UNC	7/8"	12,000	1	35406	—
4"	.020	5/8"-11 UNC	1-1/8"	9,000	1	35186	—

* See Elastomer Color Code Chart on page 61 for more information.

• Non-stock product, contact Customer Service for lead times and minimum order quantities.

P **CRIMPED WIRE CUP BRUSHES** provide very flexible brushing action and the most consistent performance for demanding light-duty cleaning applications; feature a threaded nut for use on angle grinders.

Diameter	Wire Size	Arbor Hole	Trim Length	Max. RPM	Standard Pack	Item Number	
						Steel	Stainless
3"	.014	M10 x 1.25 M14 x 2.0 3/8"-24 UNF 1/2"-13 UNC 5/8"-11 UNC	1"	14,000	1	13240 ▲	—
						13242	—
						13243	—
						13244	—
						13245 PV	—
3-1/2"	.014	M10 x 1.25 M14 x 2.0 3/8"-24 UNF 5/8"-11 UNC	7/8"	13,300	1	—	13182
						13177 •	—
						13178	—
						13181 V	13188
4"	.0118 .014 .020	5/8"-11 UNC	1-3/8"	10,200	1	14016	—
						14026 V	—
						14036 P ▲	14126
5"	.014 .020	5/8"-11 UNC	1-1/4"	9,000	1	14206 V ▲	—
						14216	14256
6"	.014 .020	5/8"-11 UNC	1-1/4"	6,600	1	14066 V *	—
						14076 ▲ *	14166 *

* With internal nut ▲ Available in non-sparking brass & bronze wire, see page 102-103 for details.

P V Display Packed & Vending Ready product available, add P or V to the end of item number when placing order.

BOLD BLACK ITEM numbers indicate color-coded brushes for easy identification.



Crimped wire cup brush removing rust from a steel rail part.



13245



36237

V **WOLVERINE® CRIMPED WIRE CUP BRUSHES** provide flexible brushing action and cost-effective performance in general purpose cleaning applications.

Diameter	Wire Size	Arbor Hole	Trim Length	Max. RPM	Standard Pack	Item Number
						Steel
3"	.014	5/8"-11 UNC	1"	14,000	1	36231
4"	.020	5/8"-11 UNC	1-1/8"	9,000	1	36236
6"	.020	5/8"-11 UNC	1-1/2"	6,600	1	36237 *

* With internal nut

CUP BRUSHES WITH STEM

Designed primarily for use on high speed die grinders, cup brushes with permanently attached stems can also be used on drills.



NOTE

If a different arbor hole is required (than listed in the tables) refer to Threaded Adapter Chart shown on Pg. 71.

P **UTILITY CRIMPED WIRE CUP BRUSHES** are smaller diameter cup brushes which provide flexible brushing action and consistent performance for more demanding light-duty cleaning applications; featuring a 1/4" stem for use on air tools.



Diameter	Wire Size	Trim Length	Overall Length	Max. RPM	Standard Pack	Item Number	
						Steel	Stainless
1-3/4"	.006 .0118	3/4"	2-5/16"	13,000	10	14300 ▲	14303 •
						14301 V ▲	14304
2"	.008 .0118	5/8"	2-7/8"	13,000	10	14313 •	14318 •
						14306	—
						14315 •	14320 •
2-1/2"	.008 .014	7/8"	3-1/8"	13,000	10	14317	14321 •
						14302 V ▲	—

▲ Available in non-sparking brass wire, see page 102-103 for details.

P V Display Packed & Vending Ready product available, add P or V to the end of item number when placing order.



14301

V **WOLVERINE UTILITY CRIMPED WIRE CUP BRUSH** is a flexible and economic small diameter brushing tool for a broad range of general purpose applications using air tools or drills. 1/4" Stem.



Diameter	Wire Size	Trim Length	Overall Length	Max. RPM	Standard Pack	Item Number
						Steel
3"	.014	1"	3-1/4"	13,000	1	36230



36230

• Non-stock product, contact Customer Service for lead times and minimum order quantities.

COATED ABRASIVES
NON-WOVEN ABRASIVES

POWER BRUSHES

NYLON BRUSHES

PACKAGED ITEMS

MAINTENANCE

STEM-MOUNTED END BRUSHES



Cleaning hard-to-reach fillet welds on a gusseted base plate.

Wire end brushes are for use on high-speed portable power tools for addressing smaller surfaces and recessed areas. End brushes feature an integral 1/4" steel stem for safe operation at high speed and quick mounting into the collet or chuck of either electric or pneumatic die grinders.

End brushes are available in a variety of knot wire and crimped wire configurations for use in a broad range of applications, and they are manufactured with the highest quality construction for smooth, efficient performance and long life. Weiler's end brushes are available in heat-treated steel, Type 302 stainless steel, and bronze or brass wire.

APPLICATIONS

- Cleaning ID's, internal passages and recessed areas
- Deburring internal edges and crosshole intersections
- Removal of die flash and excess molded material
- Spot facing

MADE IN USA
WITH GLOBAL MATERIALS



10026



10031

P **KNOT WIRE END BRUSHES** feature a hollow end and heavy-duty brushing action with some flexibility; ideal for more demanding cleaning applications in recessed areas.



Diameter	Wire Size	Trim Length	Overall Length	Max. RPM	Standard Pack	Item Number	
						Steel	Stainless
1/2"	.006	1-1/8"	2-7/8"	20,000	10	-	10215 *
	.0104					10208	10216
	.014					10217	10218
3/4"	.006	1-1/8"	2-7/8"	20,000	10	-	10220 *
	.0104					10210	10211
	.014	7/8"	2-5/8"	25,000	10025 P	10029 V	
	.020				10026 P	10030	
1-1/8"	.006	1-1/8"	2-9/16"	20,000	10	10141 V *	10142 • *
	.0104		2-7/8"			10212	10213
	.0118	7/8"	2-5/8"	22,000	10187	-	
	.014				10027 PV	10031	
	.020				10028 PV ▲	10032	

• Coated cup * Globally sourced product

▲ Available in non-sparking bronze wire, see page 102-103 for details.

BOLD BLACK ITEM numbers indicate color-coded brushes for easy identification.

P V Display Packed & Vending Ready product available, add P or V to the end of item number when placing order.

P **KNOT WIRE END BRUSHES - Nickel-plated Cup compliant with DOD MIL STD 2041D(SH)**

Feature a hollow end and heavy-duty brushing action with some flexibility; ideal for more demanding cleaning applications in recessed areas.



10392

Diameter	Wire Size	Trim Length	Overall Length	Max. RPM	Standard Pack	Item Number	
						Steel	Stainless
3/4"	.014	7/8"	2-5/8"	22,000	10	10387 •	10388 •
	.020					10392	10393 •
1-1/8"	.014	7/8"	2-5/8"	22,000	10	10392	10393 •
	.020					10392	10393 •

V **WOLVERINE® KNOT WIRE END BRUSHES** feature similar hollow-end construction and heavy-duty brushing action, but they have been engineered to provide cost-effective use for less demanding applications.



36251

Diameter	Wire Size	Trim Length	Overall Length	Max. RPM	Standard Pack	Item Number	
						Steel	Stainless
3/4"	.014	7/8"	2-5/8"	22,000	10	36286	36287 •
	.020		2-9/16"			36250	-
1"	.014	7/8"	2-5/8"	22,000	10	36288	36289
	.020		2-9/16"			36251	-

BOLD BLACK ITEM numbers indicate color-coded brushes for easy identification.

P **KNOT WIRE END BRUSHES - Banded** - Feature a pair of bands around the fill to reduce the exposed trim length and limit brush flaring to provide a very aggressive, controlled brushing action.



11141

Diameter	Wire Size	Trim* Length	Overall Length	Max. RPM	Standard Pack	Item Number	
						Steel	Stainless
1-1/8"	.014	3/8"	2-5/8"	18,000	10	11140	11141
	.020					11140	11141

* Trim length from bands

• Non-stock product, contact Customer Service for lead times and minimum order quantities.

P **CRIMPED WIRE END BRUSHES** feature a solid end construction and very flexible brushing action ideal for more demanding light-duty cleaning applications in corners and hard-to-reach areas.



Diameter	Wire Size	Trim Length	Overall Length	Max. RPM	Standard Pack	Item Number	
						Steel	Stainless
3/8"	.0118	7/8"	2-1/2"	20,000	10	10188	–
1/2"	.006	7/8"	2-9/16"	25,000	10	10001 ▲	10013
	.0104					10002	10014
	.014					10003	10015
	.020					10004	10016
	10005					10017 ▣	
3/4"	.006	7/8"	2-9/16"	22,000	10	10006	10018
	.0104					10007	10019
	.014					10008	10020
	.020					10009 ▲ ▣	10021 ▣
	10010 ▣					10022	
1"	.006	1"	2-3/16"	22,000	10	10011 ▲	10023
	.0104					10012 ▣	10024
	.014						
	.020						

▲ Available in non-sparking brass wire, see page 102-103 for details. **BOLD BLACK ITEM** numbers indicate color-coded brushes for easy identification.
P ▣ Display Packed & Vending Ready product available, add P or V to the end of item number when placing order.



Cleaning the exhaust port of a gasoline engine.



10013

P **CRIMPED WIRE END BRUSHES - Coated Cup** - Feature a solid end construction and very flexible brushing action ideal for more demanding light-duty cleaning applications in corners and hard-to-reach areas. The plastic sleeve covering the cup protects the work surface from being scratched or marked.



Diameter	Wire Size	Trim Length	Overall Length	Max. RPM	Standard Pack	Item Number	
						Steel	Stainless
1/2"	.006	7/8"	2-9/16"	25,000	10	11000	11010
	.0104					11001	11011
3/4"	.006	7/8"	2-9/16"	22,000	10	11003	11013
	.0104					11004	11014
1"	.006	7/8"	2-3/4"	22,000	10	11006	11016
	.0104					1" 11007	11017

BOLD BLACK ITEM numbers indicate color-coded brushes for easy identification.



10010



11013

P **CRIMPED WIRE END BRUSHES - Nickel-plated Cup** - Feature a solid end construction and very flexible brushing action ideal for more demanding light-duty cleaning applications in corners and hard-to-reach areas. **The nickel-plated cup is compliant with DOD MIL STD 2041D(SH).**



Diameter	Wire Size	Trim Length	Overall Length	Max. RPM	Standard Pack	Item Number	
						Steel	Stainless
1/2"	.0104	7/8"	2-9/16"	25,000	10	10371 •	
3/4"	.006	7/8"	2-9/16"	22,000	10	10374 •	
	.020					10377 •	
1"	.006	1"	2-7/8"	22,000	10	10378	
	.0104					10379	
	.014					10380 •	
	.020					1-1/8" 2-15/16"	10381 •



10374

V **WOLVERINE® CRIMPED WIRE END BRUSHES** feature similar solid end construction and flexible brushing action, but they have been engineered to provide cost-effective use for less demanding applications.



Diameter	Wire Size	Trim Length	Overall Length	Max. RPM	Standard Pack	Item Number	
						Steel	Stainless
1/2"	.0104	7/8"	2-9/16"	25,000	10	36282	–
3/4"	.006	7/8"	2-9/16"	22,000	10	–	36283
	.0104					36247	–
	.014					36246	–
1"	.006	7/8"	2-3/4"	22,000	10	36284	36285
	.0104					36249	–
	.014					36248	–

BOLD BLACK ITEM numbers indicate color-coded brushes for easy identification.



36247

• Non-stock product, contact Customer Service for lead times and minimum order quantities.

COATED ABRASIVES

NON-WOVEN ABRASIVES

POWER BRUSHES

NYLON BRUSHES

PACKAGED ITEMS

MAINTENANCE



P CRIMPED WIRE END BRUSHES - Banded - Feature bands around the fill to reduce the exposed trim length and limit brush flaring at operating speed to provide an aggressive, controlled brushing action.

Diameter	Wire Size	Trim Length*	Overall Length	Max. RPM	Standard Pack	Item Number	
						Steel	Stainless
1/2"	.006	9/16"	2-9/16"	20,000	10	11100	11110
	.0104			22,000		11101	—
3/4"	.006	7/16"	2-11/16"	20,000	10	11102	11112
	.0104	3/8"				11103	11113
1"	.006	3/8"	2-5/8"	13,000	10	—	11114
	.0104					11105	11115

* Trim length from bands

BOLD BLACK ITEM numbers indicate color-coded brushes for easy identification.



11112



10310

P *CONTROLLED FLARE END BRUSHES feature uniquely trimmed crimped wire fill for more effective brushing action and greatly enhanced durability when cleaning corners and fillet welds.

Diameter	Wire Size	Trim Length	Overall Length	Max. RPM	Standard Pack	Item Number	
						Steel	Stainless
1/2"	.0104	7/8"	2-9/16"	25,000	10	10301	10313
	.014					10302	10314
	.020					10303	10315
3/4"	.0104	7/8"	2-9/16"	22,000	10	10305	10317
	.014					10306	—
	.020					10307	10319
1"	.0104	1"	2-7/8"	22,000	10	10309	10321 •
	.014					10310	10322
1"	.020	1-1/8"	2-15/16"	22,000	10	10311	10323

*Patent #8,186,000 B2

BOLD BLACK ITEM numbers indicate color-coded brushes for easy identification.

The unique trim of a controlled flare end brush is designed specifically to address hard-to-reach areas, reducing filament fatigue and breakage typically associated with a standard end brush when cleaning corners and fillet welds.



Standard Crimped Wire End Brush



Controlled Flare End Brush



P CRIMPED WIRE PILOT BONDING BRUSHES - Banded - Solid end. Originally designed to clean around rivet holes in aluminum aircraft panels but may be used in other similar applications.

Diameter	Wire Size	Trim Length	Overall Length	Pilot Diameter	Max. RPM	Standard Pack	Item Number
							Stainless
1/2"	.005	3/8"	2-1/4"	3/32"	20,000	10	10056*
				1/8"			10057*
				5/32"			10058*
				3/16"			10059*

* Globally sourced product



10059

P POLYFLEX® ENCAPSULATED CRIMPED WIRE END BRUSHES

Burgundy Elastomer* - Feature fill material that has been encapsulated in an elastomer that gradually wears away to keep only the wire tips exposed; ideal for applications such as spot facing that may require maximum aggression and no flaring.

Diameter	Wire Size	Trim Length	Overall Length	Max. RPM	Standard Pack	Item Number	
						Steel	Stainless
Burgundy Elastomer* - Standard							
1/2"	.0104	7/8"	2-9/16"	18,000	10	35340	35500
3/4"	.0104	7/8"	2-9/16"	16,000	10	35345	—
1"	.0104	7/8"	2-3/4"	14,000	10	35350	—
Orange Elastomer* - Heavy-Duty							
3/4"	.0104	7/8"	2-9/16"	16,000	10	35540	—

* See Elastomer Color Code Chart on page 61 for more information.



35350

P **CIRCULAR FLARED END BRUSHES** feature crimped wire fill that has been “z-flared” to match the working angle of the brush at operating speed; suited for addressing broad and slightly contoured surfaces.



Diameter	Wire Size	Max. RPM	Standard Pack	Item Number	
				Steel	Stainless
1"	.006	25,000	1	10033	10042
	.008			10034	10043
	.020			10099	—
1-1/4"	.006	20,000	1	10076	—
	.008			10035	—
	.020			10044	10045
1-1/2"	.006	20,000	1	10037	10046
	.008			10038	10047
	.020			11142	—
2"	.014	25,000	2	10039	10048
2-3/4"	.008	16,000	2	10040	—
	.020			10150	10151
	.014			10041 V	10050
3"	.006	16,000	2	10134	—
	.008			10073	—
	.020			—	—

P V Display Packed & Vending Ready product available, add P or V to the end of item number when placing order.
BOLD BLACK ITEM numbers indicate color-coded brushes for easy identification.



P **POLYFLEX® ENCAPSULATED CIRCULAR FLARED END BRUSHES**

Black Elastomer* - Crimped wire fill that has been encapsulated in a heavy-duty elastomer that gradually wears away to keep only the wire tips exposed. Their saucer-shape, narrow face, and aggressive brushing action make them suitable for addressing edges, corners, and confined areas.



O.D. Diameter	Wire Size	Cup Size	Overall Length	Max. RPM	Standard Pack	Item Number	
						Steel	Stainless
1-3/4"	.006	3/4"	2"	25,000	2	35222	—
	.0104					35223	35226
	.020					35224	—
2"	.0104	3/4"	1-1/8"	20,000	2	35233	—
	.020					35234	—

* See Elastomer Color Code Chart on page 61 for more information.



P **PENCIL END BRUSHES** contain straight wire fill material retained in a small diameter steel tube. They provide a light-duty brushing action suitable for very small recessed areas.



Tube Diameter	Wire Size	Trim Length	Overall Length	Max. RPM	Standard Pack	Item Number	
						Steel	Stainless
1/4"	.0104	3/4"	3-3/4"	8,000	10	99825	99823



When brushing a recessed area or the inside diameter of a tube, use an End Brush in the following manner: Insert the brush, start the brush rotating. Turn off the power before removing the brush. This will prevent the brush from flaring out and enable it to fit into the recessed area again.



1. Insert Brush 2. Apply Power 3. Shut-Off Power 4. Remove Brush



MOUNT END BRUSHES SAFELY

When mounting end brushes, the amount of overhang from the tool should be minimized by clamping on as much of the straight portion of the stem as possible. However, the collet or chuck should NOT clamp on the radius at the base of the stem to insure a secure hold before use. See photo above for the correct brush orientation.

WHY WEILER BONDED ABRASIVES COATED ABRASIVES NON-WOVEN ABRASIVES POWER BRUSHES NYLON BRUSHES PACKAGED ITEMS MAINTENANCE

BORE-RX™ CROSSHOLE DEBURRING BRUSHES



Deburring intersecting oil passages in an engine block.

MADE IN USA
WITH GLOBAL MATERIALS

Designed for automated use in CNC machining centers and dedicated equipment. They are densely filled for high aggression and long tool life and feature a 3/8" diameter steel stem with a flat for use in a collet or end-mill holder.

Bore-Rx brushes are ideal tools for removing burrs from internal edges. Since they can eliminate manual deburring operations, these internal brushing tools help to improve part-to-part consistency and reduce direct labor costs. Bore-Rx brushes are available in sizes ranging from 3/4" to 4" in diameter, and they are designed to be interpolated within bore sizes that are larger than the brush diameter.

Operating Parameters For Wire Bore-Rx Brushes

Brush Diameter	Recommended RPM	Recommended Feed Rate
5/8" - 7/8"	8,000	20"/min
1" - 1-1/2"	8,000	20"/min
2" - 2-1/2"	6,000	20"/min
3" - 4"	3,000	20"/min

Tool Paths for Crosshole Deburring

An effective tool path for most crosshole deburring jobs is circular interpolation using the following guidelines to determine diameter of interpolation. The interpolation should be performed at a depth where the center of the brush face is at the center of the intersecting hole.

$$\text{Diameter of Interpolation} = \text{Hole Diameter} - \text{Brush Diameter}$$



17207



BORE-RX™ BRUSHING TOOLS - Crimped wire fill - Feature dense wire fill for aggressive deburring action on ductile metals and other hard-to-deburr materials.

Diameter	Wire Size	Face Width	Overall Length	Max. RPM	Standard Pack	Item Number
						Steel*
3/4"	.005	3/8"	4-3/8"	8,000	1	17202 •
1"	.006	3/4"	5"	8,000	1	17207 •
1-1/4"	.006	3/4"	4-3/4"	8,000	1	17209 •
1-1/2"	.006	1"	5"	8,000	1	17211 •
2"	.006	1"	4-1/4"	6,000	1	17214 •
2-1/2"	.008	1"	4-3/4"	6,000	1	17216 •
3"	.008	1"	5-1/4"	6,000	1	17218 •

* Stainless Steel fill is available by special order.

• Non-stock product, contact Customer Service for lead times and minimum order quantities.

Note: All Bore-Rx brush stems have a 2" long flat for use in end mill holders. Alternatively, they can be mounted in 3/8" collets. Bore-Rx extension holder is available. To discuss specific requirements with a specialist call: 800-835.9999.



17218

CUSTOMIZABLE CROSSHOLE DEBURRING SOLUTIONS

Replacement Bore-Rx Brush Heads and Reusable Bore-Rx Arbors

In high production applications, reusable arbors reduce manufacturing costs by allowing the use of inexpensive brush head replacements. Brush heads are made-to-order in diameters ranging from 3/4" to 1-1/2" with face widths of 1/4" to 1". They are available on 3/16" and 1/4" pins. The pin diameter is based on the application and determines brush density. To discuss specific requirements with a specialist call: 800-835.9999.



Replacement Head



Reusable Extension 03991 •



Reusable Arbor 03993 •

POWER AND HAND TUBE BRUSHES

Weiler offers a comprehensive line of power and hand tube brushes for internal cleaning and deburring applications in tubing, pipe, drilled-and-tapped holes, and machined bores and passages. Due to their twisted-in-wire construction, the use of power tube brushes is limited to low-speed power tools such as drills and drill presses and to CNC and manual machine tools in which the RPM can be precisely programmed or set. In addition, they should not be used in reverse rotation to prevent unraveling of the stem wire. Available in a wide variety of brush configurations and fill materials, Weiler can supply a tube brush for any application. If you do not see what you need in this catalog, see the Special Tube Brush Design Specification Sheet on page 85, or call 800-835.9999 for assistance.

APPLICATIONS

- Deburring and cleaning drilled-and-tapped holes and other internal threads
- Cleaning and finishing the ID of tubing and pipe
- Crosshole deburring
- Removing burrs and chips from internal keyways, slots, and grooves
- Removing paint, coatings, and build-up other foreign material from the surfaces of bores and passages

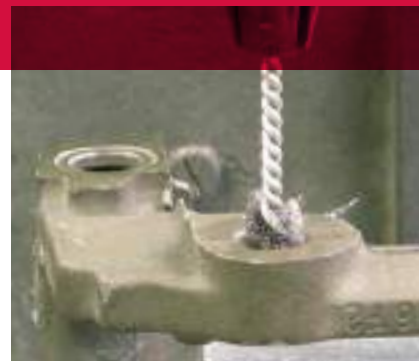

Removing zinc coating from holes in a brake bracket.

POWER AND HAND TUBE BRUSH SELECTION TIPS

- A flat burr style tube brush is most effectively used with a holder on blind, threaded holes.
- A round tube brush is most effectively used fully chucked on smooth or threaded blind holes.
- A single stem, single spiral tube brush is most effectively used for manual or hand cleaning applications.
- A double stem, double spiral tube brush is most effectively used with power tools for heavy-duty cleaning and deburring.
- A polyflex encapsulated double stem, double spiral tube brush is most effectively used on power tools for very aggressive cleaning and deburring applications.



P **DOUBLE STEM, DOUBLE SPIRAL** feature four stem wires and a double spiral of straight wire fill material to provide aggressive cleaning and deburring action.



Diameter	Wire Size	Brush Part	Stem Diameter	Overall Length	Max. RPM	Standard Pack	Item Number	
							Steel	Stainless
3/8"	.003	1-1/2"	1/8"	4"	2,000	10	21342	–
	.006	2-1/8"		6"			21232	–
1/2"	.004	2"	5/32"	5"	2,000	10	21106	21116
	.006						21107 V ▲	21117
	.0104						21252	–
5/8"	.005	2"	7/32"	5"	2,000	10	21108 V	21118
	.008						21109 ▲	21119
	.0104						21184	–
3/4"	.006	2-1/2"	1/4"	5-1/2"	2,000	10	21110 V ▲	21120
	.008						21247	–
	.0104						21111	21121
7/8"	.006	2-1/2"	1/4"	5-1/2"	2,000	10	21112	21122
	.0104						21113	–
1"	.006	2-1/2"	1/4"	5-1/2"	2,000	10	21114 V ▲	21124
	.0104						21115	21125
1-1/4"	.006	2-1/2"	1/4"	5-1/2"	2,000	10	21164	21245
	.0104						21167 ★	21236
1-1/2"	.014	2-1/2"	1/4"	5-1/2"	2,000	10	–	21413

★ 5" Overall length ▲ Available in non-sparking brass wire, see page 102-103 for details.

P **V** Display Packed & Vending Ready product available, add P or V to the end of item number when placing order.



COATED ABRASIVES

NON-WOVEN ABRASIVES

POWER BRUSHES

NYLON BRUSHES

PACKAGED ITEMS

MAINTENANCE

P POLYFLEX™ ENCAPSULATED DOUBLE STEM, DOUBLE SPIRAL

Burgundy Elastomer® - Encapsulated with an elastomer that leaves only the sharp wire tips exposed for maximum aggression and a very rigid brushing action.



35825

Diameter	Wire Size	Brush Part	Stem Diameter	Overall Length	Max. RPM	Standard Pack	Item Number	
							Steel	
1/2"	.006	2"	5/32"	5"	2,000	10	35821	•
5/8"	.0104	2"	7/32"	5"	2,000	10	35822	
3/4"	.0104	2-1/2"	1/4"	5-1/2"	2,000	10	35823	
1"	.0104	2-1/2"	1/4"	5-1/2"	2,000	10	35825	•

* See Elastomer Color Code Chart on page 61 for more information.

• Non-stock product, contact Customer Service for lead times and minimum order quantities.

P ROUND - Feature a single continuous length of stainless steel stem wire and a single spiral of crimped wire fill for a more flexible brushing action; for use on smooth or threaded blind holes.



21074

Diameter	Wire Size	Brush Part	Stem Diameter	Overall Length	Max. RPM	Standard Pack	Item Number	
							Steel	Stainless
1/4"	.004	1"	1/8"	3-1/2"	2,000	10	21072 ▲	21081 ▼
5/16"	.005	1"	1/8"	3-1/2"	2,000	10	21175	–
3/8"	.004	1"	1/8"	3-1/2"	2,000	10	21073	21082
	.006						–	
	.008						21264	21240
7/16"	.005	1"	1/8"	3-1/2"	2,000	10	21142	21181
1/2"	.005	1"	3/16"	3-1/2"	2,000	10	21074 ▼ ▲	21083
9/16"	.005	1"	3/16"	3-1/2"	2,000	10	21143	–
							.0104	–
5/8"	.005	1"	3/16"	3-1/2"	2,000	10	21075 ▼	21084
							.008	–
11/16"	.005	1"	3/16"	3-1/2"	2,000	10	21144	–
3/4"	.006	1"	7/32"	3-1/2"	2,000	10	21076	21085
							.008	–
7/8"	.006	1"	7/32"	3-1/2"	2,000	10	21077 ▼	21086
							.008	–
15/16"	.005	1"	7/32"	3-1/2"	2,000	10	21148 •	–
1"	.005	1"	1/4"	3-1/2"	2,000	10	21149	21340
							.008	–
1-1/8"	.005	1"	1/4"	3-1/2"	2,000	10	21150	–
							.008	–
1-1/4"	.008	1"	1/4"	3-1/2"	2,000	10	21080	21089
1-1/2"	.008	1"	1/4"	3-1/2"	2,000	10	21203 ▲	–
							.0104	–
2-1/4"	.008	1"	1/4"	3-1/2"	2,000	10	21322	–

▶ ▼ Display Packed & Vending Ready product available, add P or V to the end of item number when placing order.

▲ Available in non-sparking brass wire, see page 102-103 for details.

• Non-stock product, contact Customer Service for lead times and minimum order quantities.

Correct Mounting
in Chuck



Incorrect Mounting
in Chuck



TUBE BRUSH OPERATING RECOMMENDATIONS

The stems in power tube brushes are not as strong as the stems in most other brushes. Therefore, it is very important to avoid any load conditions and brush speeds that can cause excessive stem deflections and destructive bending.

A suggested guideline to avoid this unsafe condition is minimizing the overhang of the stem to under an inch, and running the brush at speeds below 2,000 RPM.

Increasing overhang could decrease the safe speed at which the brush can operate. To reach into deeper holes, use drill extension rods instead of increasing stem overhang.

BEFORE STARTING THE BRUSH:

- Secure brush in chuck.
- Ensure clockwise brush rotation (running the brush counter-clockwise could cause the brush to fall apart).
- Clamp work securely.
- Position all guards in place.
- Align brush with the work so the brush rotates on its true centerline to prevent any stem deflections.
- Guide the brush into the hole before starting the brush rotation.
- Always wear eye protection.

P

BURRITE - Feature a single continuous length of stainless steel stem wire and filled with a tuft of crimped wire to provide an aggressive flat side action; ideal for cleaning and deburring internal threads.



Diameter	Wire Size	Brush Part	Stem Diameter	Overall Length	Max. RPM	Standard Pack	Item Number	
							Steel	Stainless
1/4"	.003	9/16"	3/32"	2-1/8"	2,000	10	21000	-
	.005						21001	21050
5/16"	.003	9/16"	3/32"	2-1/8"	2,000	10	21004	-
	.005						21005	-
3/8"	.003	9/16"	3/32"	2-1/8"	2,000	10	21008	-
	.005						21009	21051
	.005						21023	-
7/16"	.005	9/16"	3/32"	2-1/8"	2,000	10	21015	-
1/2"	.005	9/16"	3/32"	2-1/8"	2,000	10	21021	21053
	.005						21025	-
9/16"	.003	5/8"	1/8"	2-1/4"	2,000	10	21027	-
	.005						21028	-
5/8"	.005	5/8"	1/8"	2-1/4"	2,000	10	21031	21055
3/4"	.005	5/8"	1/8"	2-1/4"	2,000	10	21034	21056
	.005						21035	-
	.008						-	-
1"	.005	5/8"	1/8"	2-1/4"	2,000	10	21040	21058
	.008						21041	-



Deburring the threads of a tapped hole using a burrite brush in a holder.



21023



21040

P

BURRITE HOLDERS - Feature a 1/4" stem for convenient mounting into the chuck of a drill or the collet of a machine tool and allow the brush to be used in either direction of rotation. They allow the brush to be used in a standard tapping cycle for deburring threaded holes in CNC machining centers.



For Brush Stem Dia.	Holder Diameter	Overall Length	Standard Pack	Item Number
3/32"	1/4"	3-1/8"	5	95202
1/8"	3/8"	3-3/8"	5	95203



95203

P

SINGLE STEM, SINGLE SPIRAL - Feature a single continuous length of galvanized steel stem wire with a formed eye loop for convenient hand use. The single spiral of straight wire fill allows for easy manual insertion into the ID.

Diameter	Wire Size	Brush Part	Stem Diameter	Overall Length	Standard Pack	Item Number	
						Steel	Stainless
1/8"	.003	1"	3/32"	6"	10	21246	21249
3/16"	.003	1-1/2"	3/32"	7"	10	21090 ▲	21098
	.005					21091	21099
1/4"	.003	1-1/2"	3/32"	7"	10	21092 ▲	21100
	.005					21093 ▲	21101
	.006					21161	-
3/8"	.004	2"	1/8"	8"	10	21094 ▲	21414
	.006					21095	21103
1/2"	.004	2"	1/8"	8"	10	21096 ▲	21104
	.006					21097	21105
	.008					21162	-
9/16"	.005	2-1/2"	5/32"	9"	10	21233	-



21096

▲ Available in non-sparking brass wire, see page 102-103 for details.

• Non-stock product, contact Customer Service for lead times and minimum order quantities.

COATED ABRASIVES

NON-WOVEN ABRASIVES

POWER BRUSHES

NYLON BRUSHES

PACKAGED ITEMS

MAINTENANCE

P NYLON HAND TUBE BRUSHES feature a single continuous length of galvanized steel stem wire with a formed eye loop for convenient hand use. The single spiral of straight nylon fill allows for easy manual insertion and scratch-free cleaning of the ID.



Diameter	Fill Diameter	Brush Part	Stem Diameter	Overall Length	Standard Pack	Item Number
						Nylon
1/4"	.005	2"	3/32"	6-1/4"	36	44110*
3/8"	.005	2"	3/32"	6-1/4"	36	44213*
1/2"	.010	3"	1/8"	8-1/2"	36	44111*
3/4"	.012	3"	1/8"	8-1/2"	36	44112*
1"	.014	4"	5/32"	12-1/4"	36	44113*
1-1/4"	.014	4"	5/32"	13"	36	44114*
2"	.014	5"	3/16"	16-3/4"	36	44115*

* Globally sourced product

P PERCOLATOR BRUSH features single stem, single spiral construction with an eye loop and straight white nylon fill. Intended for cleaning the internal passages in coffee percolators, this brush can be also be used in other similar manual cleaning applications.



Diameter	Fill Diameter	Brush Part	Stem Diameter	Overall Length	Standard Pack	Item Number
						Nylon
7/16"	.010	3-1/2"	5/32"	11-1/2"	10	44316

P VALVE GUIDE BRUSHES are made with single stem, single spiral construction and have a permanently-attached 1/4" diameter long steel handle for convenient hand use or for mounting into a chuck. Intended for removing heavy deposits from valve guides in gas and diesel engines, these brushes can also be used in a range of other similar applications.



Diameter	Fill Diameter / Material	Brush Part	Overall Length	Max. RPM	Standard Pack	Item Number
3/8"	.0104 Steel	2"	10"	2,000	10	95028
7/16"						95665 •
1/2"						95029
11/32"	.008 Nylon	2-1/2"	10"	2,000	10	95660 •
3/8"	.012 Nylon					95567 •

P GUN CLEANING BRUSHES - Rifle Brushes - Constructed using a continuous piece of stem wire and fine bronze wire fill for a scratch-free cleaning action in gun barrels, these flexible tube brushes are designed to be attached to extension rods using the 8-32 male coupling.



Caliber	Brush Part	Overall Length	Coupling Size	Standard Pack	Item Number
					Bronze
22	2-1/4"	3-1/4"	8-32	10	95301
30	2-1/4"	3-1/4"	8-32	10	99786 •
45	2-1/4"	3-1/4"	8-32	10	99791 •

P GUN CLEANING BRUSHES - Shotgun Brushes - Constructed using a continuous piece of stem wire and fine bronze wire fill for a scratch-free cleaning action in gun barrels, these flexible tube brushes are designed to be attached to extension rods using the 5/16"-27 male coupling.



Gauge	Brush Part	Overall Length	Coupling Size	Standard Pack	Item Number
					Bronze
12	1-5/8"	2-7/8"	5/16-27	10	99714
410	1-5/8"	2-7/8"	5/16-27	10	95129 •

• Non-stock product, contact Customer Service for lead times and minimum order quantities.

SPECIAL TUBE BRUSH SPECIFICATION SHEET:

(Use the illustration on this page as a guide)

1. Brush diameter _____
2. Length of brush part _____
3. Overall brush length _____
4. Special stem diameter (if required) _____
5. Stem material:
 Galvanized Steel Stainless Other
6. Application _____
7. Brush fill material:
 Steel wire Stainless wire
 Nylon Abrasive Filament (Nylox®)
 Brass wire Other _____
8. Fill material diameter _____
9. Special tip style (if required) _____
10. Single stem Double stem
11. Order Quantity _____

* Special tube brushes are not returnable, as they are manufactured to order.

Name: _____
 Company Name: _____
 Address: _____
 Phone: (_____) _____
 Fax: (_____) _____
 E-mail: _____

End-User Name: _____
 City: _____
 State: _____ Zip: _____

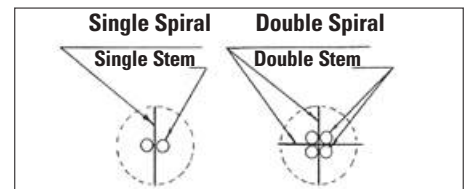
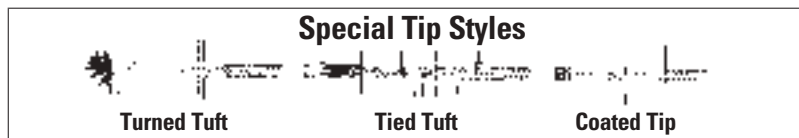
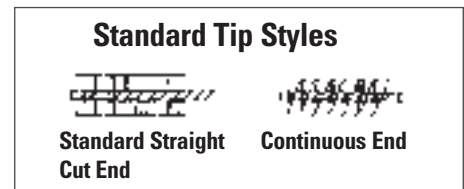
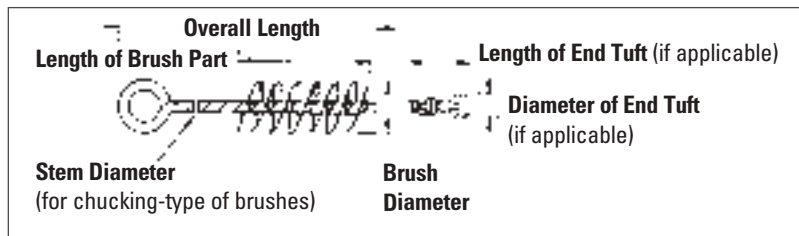

FOR ADDITIONAL INFORMATION CALL:

To discuss specific requirements with a specialist call: 800-835.9999



CROSSFLEX™

Cross hole deburring and honing solutions for off-hand and automated applications.

See pages 96-98

WHY WEILER BONDED ABRASIVES COATED ABRASIVES NON-WOVEN ABRASIVES POWER BRUSHES NYLOX BRUSHES PACKAGED ITEMS MAINTENANCE

CROSSFLEX™ HONING BRUSHES

CrossFlex offers machinists the right combination of performance and value for professional honing applications. Flexible filaments provide the correct pressure to create an ideal hone; one bore after another. It's the ideal tool to create cross-hatch patterns for improved oil retention and increased part efficiency. The strong self-centering system leaves a smooth, even surface finish free of metal burrs whether used in a manual or automated application.



Deburring cross holes in a firearms component.

No matter what type or size cylinder, Weiler's CrossFlex brushes deliver the options you need to solve your toughest deburring and honing challenges.

CROSSFLEX ABRASIVE GRITS: Every individual brush end tip is colored to indicate the grit of that brush.



FEATURES & BENEFITS:

- **Desired Finish**
CrossFlex offers a wide range of grits and sizes allowing machinists to achieve the desired finish.
- **Heavy Burr Removal**
Increased brush to part contact ensures that the heaviest burrs will be removed, outperforming standard nylon tube brushes.
- **Long Life**
CrossFlex brushes have a long operational life, lowering total cost of use compared to other brush options.
- **Flexible Nylon Stems**
Distribute pressure evenly and self centers within the part to create an ideal hone.
- **Consistent Cross Hatch Pattern**
Helps to seat piston rings and retains oil for lubrication in a combustion cylinder.
- **Collet Ready Brushes**
Deliver a true center rotation and exceptional brush balance for automated applications or hand held use.

Deburring mounting holes on a machined component.

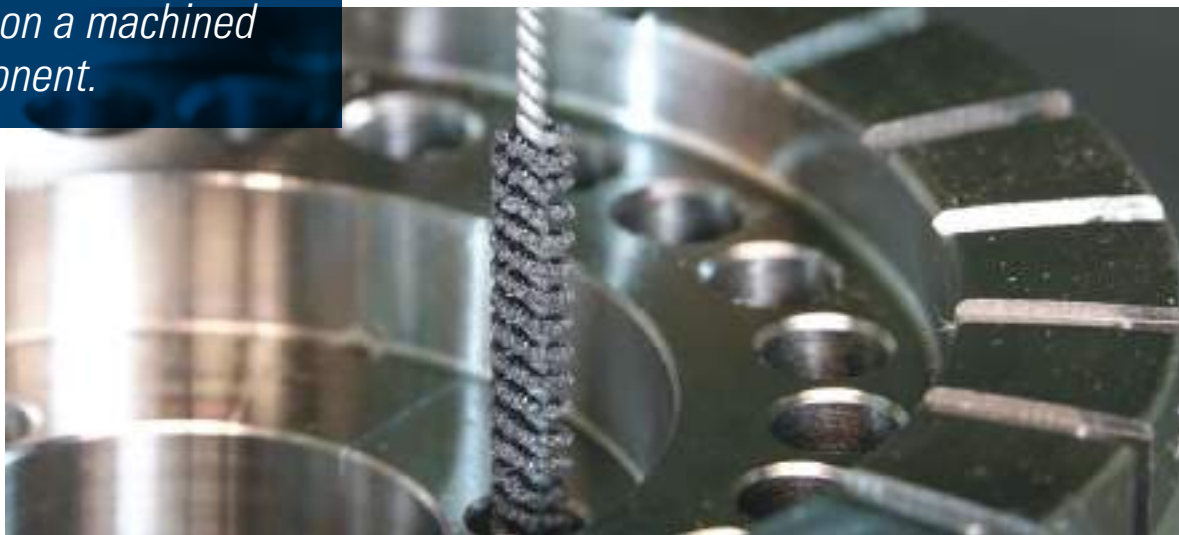

COLLET READY BENEFITS FOR SMALL DIAMETER BRUSHES:

- Reduces brush run-out
- Strengthens and sturdies brush shaft for better stability and overall reach
- Strong positive engagement with tool holder



Cleaning burrs out of an automotive head port.

SMALL DIAMETER CROSSFLEX HONING BRUSHES

Silicon carbide cross-honing brushes for standard use. Ideal for deburring small diameter cross hole intersections.



For Hole Sizes in Inches	For Hole Sizes in mm	Length of Brush Part	Overall Length	Shank Diameter	Max RPM	120 Grit Item No.	180 Grit Item No.	240 Grit Item No.	320 Grit Item No.	
0.177"	4.5 mm	0.787"	6"	0.083"	1,000	–	–	–	34107	
0.197"	5 mm	1.575"	7.875"	0.098"	900	34111	–	–	–	
0.25"	6.35 mm					34123	–	–	34126	
0.276"	7 mm	1.969"		0.13"		34127	–	–	34130	
0.315"	8 mm			0.142"		34131	–	–	34135	
0.354"	9 mm					34136	34137	–	–	34139
0.375"	9.5 mm					34141	–	34143	–	–
0.394"	10 mm					–	34146	–	–	34148
0.433"	11 mm					34149	34150	–	–	34152
0.472"	12 mm					34153	–	–	–	34156
0.5"	12.7 mm	2.48"		0.157"		34158	34159	34160 •	34161	
0.552"	14 mm			0.173"		34162	–	–	–	
0.75"	19mm			0.197"		–	34175	34176	–	
0.787"	20 mm					–	–	–	–	
0.875"	22 mm					0.213"		34182	34183	–



COLLET READY – SMALL DIAMETER CROSSFLEX HONING BRUSHES

Silicon carbide cross-honing brushes for standard use within automated applications and to reduced brush run-out.



For Hole Sizes in Inches	For Hole Sizes in mm	Length of Brush Part	Overall Length	Shaft Diameter	Max RPM	320 Grit Item No.
0.236"	6 mm	0.75"	6"	5/32"	1,000	34314 •



MEDIUM DIAMETER CROSSFLEX HONING BRUSHES

Silicon carbide cross-honing brushes for standard use. Ideal for changing the surface finish in machined bores and deburring the ID of castings.



For Hole Sizes in Inches	For Hole Sizes in mm	Length of Brush Part	Overall Length	Shank Diameter	Max RPM	120 Grit Item No.	180 Grit Item No.	240 Grit Item No.	320 Grit Item No.
1"	25.4 mm	3"	7.875"	0.213"	900	34190	34191	34192 •	–
1.25"	31.8 mm			0.252"	800	34198	34199	34200 •	34201
2"	51 mm			34222	34223 •	–	–		
2.5"	64 mm	5.5"	7.875"	0.283"	700	34238	–	–	–
3"	76 mm			–	–	–	–	34257	

• Non-stock product, contact Customer Service for lead times.

COATED ABRASIVES
NON-WOVEN ABRASIVES
POWER BRUSHES
NYLON BRUSHES
PACKAGED ITEMS
MAINTENANCE



Engine cylinder head honing.



34266

HEAVY-DUTY MEDIUM DIAMETER CROSSFLEX HONING BRUSHES

Silicon carbide cross-honing brushes for heavy-duty use. Ideal for changing the surface finish in machined bores and deburring the ID of castings.

For Hole Sizes in Inches	For Hole Sizes in mm	Length of Brush Part	Overall Length	Shank Diameter	Max RPM	120 Grit Item No.	180 Grit Item No.	240 Grit Item No.	320 Grit Item No.
3"	76 mm	5.5"	13.5"	0.311"	700	34258	—	34260	—
3.25"	83 mm					34262 •	—	34264	34265 •
3.5"	89 mm					34266	34267	34268	34269



34294

HEAVY-DUTY LARGE DIAMETER CROSSFLEX HONING BRUSHES

Silicon carbide cross-honing brushes for heavy-duty use. Ideal for cross hatching in combustion cylinders.



For Hole Sizes in Inches	For Hole Sizes in mm	Length of Brush Part	Overall Length	Shank Diameter	Max RPM	120 Grit Item No.	180 Grit Item No.	240 Grit Item No.	320 Grit Item No.
3.75"	95 mm	5.5"	13.5"	0.311"	700	34270	—	34272	34273
4"	101 mm	6.5"		0.346	600	34274	34275	34276	34277
4.25"	108 mm					34278	34279	34280	34281
4.5"	114 mm		34282			34283 •	34284	34285	
5"	127 mm	18"	18"	0.402"		34286	34287	34288 •	34289
5.5"	140 mm					34290	—	34292	34293 •
6"	152 mm					34294	34295	34296	—

• Non-stock product, contact Customer Service for lead times.

SPECIALTY BRUSHES

Weiler understands that not all your finishing or deburring applications have a standard solution. For instances where applications require unique sizes, lengths or abrasives; Weiler Process Solutions (WPS) specialists work with you to provide custom CrossFlex brushes for your specific application.

- Custom sized for your specific bore diameters
- Brushes with shorter or longer stems for your particular application
- Collet ready or other connection methods
- Options in a variety of abrasives including **silicon carbide, aluminum oxide, zirconia alumina** and **ceramic** grains



Custom large diameter ceramic CrossFlex brush.



An application engineering program designed to provide Weiler customers with engineering support to identify value added opportunities in their processes.

To learn more about Weiler's specialty solutions go to: weilerabrasives.com/wps



WEILER PROCESS SOLUTIONS



Bringing Process, Expertise & Partnership Together.

In today's competitive manufacturing landscape, improving high-volume production processes is crucial for a business to meet the demands of its customers and achieve profitability goals. When it comes to surface conditioning, having a partner you trust is crucial to realizing your continuous improvement objectives.

The **WEILER PROCESS SOLUTIONS** (WPS) program delivers customized solutions based on your specific application needs. The program leverages the latest technology and on-site technical expertise to optimize high-volume production manufacturing processes for customers.

WPS is designed to identify opportunities to make improvements that will immediately impact your business by driving down the total cost per part, increasing productivity, or both. Through the WPS program, Weiler Abrasives brings technical support and experience to your facility and works with your team to develop a tailored solution that achieves your objectives.

Benefits of WPS:

- ▶ Reduce cycle times and eliminate production bottlenecks to **improve throughput**
- ▶ **Reduce total cost per part**
- ▶ Minimize rework and reduce waste
- ▶ Improve energy efficiency and sustainability for your business
- ▶ Reduce working capital commitment by optimizing consumable inventory
- ▶ Reduce process variability to improve part quality and consistency



"I consider Weiler to be a long-term partner. Their history of meeting our specific application needs has been world-class."

– Gary S., General Manager,
Rolling Operations



Continuous improvement doesn't have to be challenging. Talk to a Weiler Abrasives Expert today to unlock your business's full potential with a WPS consultation.

MINIATURE BRUSHES



Removing galled spots from a metal forming die.

THE WEILER FAMILY began producing miniature brushes for the jewelry industry in 1898, and their tradition of providing the highest quality, most cost-effective products continues to this day.

Weiler's line of miniature brushes are designed for precision cleaning, light deburring, and finishing applications in a variety of crafts, trades, and industries. In addition to use in jewelry production and in dental and optical labs, miniature brushes have many applications in modern industries such as electronics and instrumentation production, aerospace and aircraft manufacture, and precision tool and die shops. They are permanently mounted on 1/8" or 3/32" stems for quick mounting and efficient use on high-speed electric rotary tools and air-powered pencil die grinders.

APPLICATIONS

- Decorative finishing
- Light deburring and edge blending
- Buffing and polishing of small parts
- Light-duty cleaning



P WIRE WHEEL BRUSHES - Fine crimped wire fill for light-duty cleaning and deburring.

Diameter	Wire Size	Trim Length	Stem Size	Stem Length	Max. RPM	Standard Pack	Item Number		
							Steel	Stainless	Brass
5/8"	.005	1/8"	1/8"	1-1/2"	37,000	144	—	99554	—
3/4"	.003	3/16"	1/8"	1-1/2"	37,000	144	26000	—	26001 •
	.005						26003	26005	26004 •
3/4"	.005	3/16"	3/32"	1-1/2"	37,000	144	26143	—	26144 •
1"	.003	5/16"	1/8"	1-1/2"	37,000	144	26012	26014	—
	.005						26015	26017	26016
	.005						26155 •	—	—
1-1/4"	.005	3/8"	1/8"	1-1/2"	37,000	144	26021	—	—
1-1/2"	.005	1/2"	1/8"	1-1/2"	25,000	144	26296	26294	—



P BRISTLE WHEEL BRUSHES - Natural hair fill for scratch-free cleaning of small parts or for buffing and polishing of features such as slots and grooves using abrasive compounds.

Diameter	Fill Type	Trim Length	Stem Size	Stem Length	Max. RPM	Standard Pack	Item Number
3/4"	Stiff Hair	3/16"	3/32"	1-1/2"	37,000	144	26041
	Soft Hair						26042
	Stiff Hair*						26043
	Stiff Hair		1/8"	26059			

* Double thick



P WIRE CUP BRUSHES - Fine crimped wire fill for light-duty cleaning or deburring in confined areas.

Dia.	Wire Size	Trim Length	Stem Size	Stem Length	Overall Length	Max. RPM	Standard Pack	Item Number		
								Steel	Stainless	Brass
5/8"	.003	1/4"	1/8"	1-1/2"	2"	37,000	144	26071	—	26072
	.005							26074	26076	26075



P BRISTLE CUP BRUSHES - Natural hair fill for scratch-free cleaning of confined areas or for buffing and polishing of small recessed surfaces using abrasive compounds.

Dia.	Fill Type	Trim Length	Stem Size	Stem Length	Overall Length	Max. RPM	Standard Pack	Item Number
1/2"	Stiff Hair	7/32"	3/32"	1-1/2"	2"	37,000	144	26091
9/16"	Stiff Hair	1/4"	1/8"	1-1/2"	2"	37,000	144	26093
1"	Stiff Hair	7/16"	1/8"	1-1/2"	2-3/8"	25,000	144	26095
	Soft Hair							26096 •

• Non-stock product, contact Customer Service for lead times and minimum order quantities.

P WIRE END BRUSHES - Fine crimped wire fill for light-duty cleaning or deburring in very small recessed areas or ID's.

Dia.	Wire Size	Trim Length	Stem Size	Stem Length	Overall Length	Max. RPM	Standard Pack	Item Number		
								Steel	Stainless	Brass
3/16"	.003	1/4"	1/8" 3/32"	1-1/4"	1-7/8"	37,000	144	26098 26101	26099 -	26097 -
1/4"	.005	7/16"	1/8"	1-1/4"	2-1/8"	37,000	144	26107	26108	26106
5/16"	.005	9/16"	1/8"	1-1/4"	2-3/8"	25,000	144	26113	26114	-



26114

P BRISTLE END BRUSHES - Natural hair fill for scratch-free cleaning or for buffing and polishing of very small recesses using abrasive compounds.

Dia.	Fill Type	Trim Length	Stem Size	Stem Length	Overall Length	Max. RPM	Standard Pack	Item Number
3/16"	Stiff Hair Soft Hair Stiff Hair	1/4"	1/8"	1-1/4"	1-7/8"	37,000	144	26115 26122 26116
1/4"	Stiff Hair	3/8"	1/8"	1-1/4"	2-1/8"	37,000	144	26119
5/16"	Stiff Hair	9/16"	1/8"	1-1/4"	2-3/8"	25,000	144	26121



26121

P BRISTLE END BRUSHES - Plastic Ferrule

Feature a plastic ferrule or cup to protect internal surfaces during use.

Dia.	Fill Type	Trim Length	Stem Size	Stem Length	Overall Length	Max. RPM	Standard Pack	Item Number
3/16"	Stiff Hair	1/4"	1/8"	1-1/4"	1-7/8"	37,000	144	26128
1/4"	Stiff Hair	3/8"	1/8"	1-1/4"	2-1/8"	37,000	144	26131
5/16"	Stiff Hair	9/16"	1/8"	1-1/4"	2-3/8"	25,000	144	26133



26133

P ABRASIVE NYLON END BRUSHES - Plastic Ferrule - Nylox® abrasive nylon fill for buffing and polishing without compounds. They can also be used in automated applications for precision deburring and finishing of small part features.

Dia.	Filament Dia./Grit	Trim Length	Stem Size	Stem Length	Overall Length	Max. RPM	Standard Pack	Item Number
3/16"	.018/500	1/4"	1/8"	1-1/4"	1-7/8"	37,000	144	26136
1/4"	.018/500	3/8"	1/8"	1-1/4"	2-1/8"	37,000	144	26138
5/16"	.018/500	9/16"	1/8"	1-1/4"	2-3/8"	25,000	144	26146



26136

Deburring the I.D. of a small machined part with miniature wire end brush.



• Non-stock product, contact Customer Service for lead times and minimum order quantities.

NON-SPARKING BRUSHES



Creating an antique finish on a brass plate.

Weiler offers an assortment of wire non-sparking brushes featuring high-quality bronze or brass wire that offer a very soft brushing action in comparison to steel and stainless steel and will not generate a spark when used on metal surfaces. These products are available in a variety of knot wire and crimped wire configurations for use in a broad range of surface cleaning applications, and they are manufactured with individual knot hole and solid ring construction for high performance and long life. Weiler's non-sparking power brushes are available with plain arbor holes, nuts, and permanently-attached stems for use on a variety of tools.

APPLICATIONS

- Light to medium duty cleaning of surfaces, recesses, and ID's
- Deburring component parts machined from soft, non-ferrous metals
- Cleaning molds and dies in the injection-molding and extrusion of plastics
- Maintenance activities in areas where flammable or potentially explosive materials are present, such as refineries and petrochemical plants.



P **STANDARD TWIST WHEELS** provide a heavy-duty brushing action with some flexibility; ideal for more demanding cleaning applications.



13121

Dia.	Wire Size	Arbor Hole	No. of Knots	Face Width	Trim Length	Max. AH Avail.	Thickness at Face Plates	Max. RPM	Std. Pack	Item Number Bronze
3"	.020	1/2" - 3/8"	20	3/8"	5/8"	1/2"	7/16"	25,000	10	08271
4"	.020	5/8" - 11	24	1/2"	7/8"	-	7/16"	20,000	5	13121

For threaded arbor hole adapters see page 71.

P **CRIMPED WIRE WHEELS** provide a flexible brushing action and consistent performance for light-duty cleaning and deburring applications.



01475

Diameter	Wire Size	Arbor Hole	Face Width	Trim Length	Max. AH Avail.	Thickness at Face Plates	Max. RPM	Standard Pack	Item Number Brass
6"	.005 .0118	5/8"-1/2"	1/2"	1-7/16"	1-1/4"	7/16"	6,000	2	01415 01475

For arbor hole adapters see page 82. For other available arbor holes, see Arbor Hole Variations Table on page 61.

P **SMALL DIAMETER CRIMPED WIRE WHEELS** provide a flexible brushing action and consistent performance for light-duty cleaning and deburring applications requiring a small wheel.



29078

Diameter	Wire Size	Arbor Hole	Face Width	Trim Length	Max. RPM	Standard Pack	Item Number Brass
1-1/2"	.005	3/8"	1/4"	7/16"	20,000	10	29178
2"	.005 .0118	1/2"	3/8"	1/2"	20,000	10	29059 29086
3"	.014	1/2"	5/8"	1"	20,000	10	29078

For adapters and drive arbors see page 79.

P **CONFLEX BRUSH** - Small diameter wheels permanently mounted onto a 1/4" stem to provide a very flexible brushing action.



17641

Diameter	Wire Size	Face Width	Trim Length	Max. RPM	Standard Pack	Item Number Brass
3"	.0118	1/2"	1"	20,000	10	17641 V

V Display Packed & Vending Ready product available, add P or V to the end of item number when placing order.

P **KNOT WIRE CUP BRUSHES** provide heavy-duty brushing action with some flexibility for more demanding cleaning applications on relatively flat surfaces.



13299

Diameter	Wire Size	Arbor Hole	Trim Length	Max. RPM	Standard Pack	Item Number Bronze
2-3/4"	.020	5/8"-11 UNC	1"	14,000	1	13299
4"	.020	5/8"-11 UNC	1-1/4"	10,200	1	12776

For threaded arbor hole adapters see page 71.

P **CRIMPED WIRE CUP BRUSHES** provide a very flexible brushing action for light-duty cleaning applications on somewhat irregular surfaces.



Diameter	Wire Size	Arbor Hole	Trim Length	Max. RPM	Standard Pack	Item Number	
						Bronze	Brass
3"	.020	5/8"-11 UNC	7/8"	14,000	1	13231	—
4"	.020	5/8"-11 UNC	1-3/8"	10,200	1	14616	—
5"	.014	5/8"-11 UNC	1-1/4"	9,000	1	—	14606
6"	.020	5/8"-11 UNC	1-1/4"	6,600	1	14316*	—

* With internal nut For threaded arbor hole adapters see page 71.



13231

P **UTILITY CRIMPED WIRE CUP BRUSHES** - Smaller diameter cup brushes that provide a flexible brushing action for light-duty cleaning applications.



Diameter	Wire Size	Trim Length	Stem Diameter	Overall Length	Max. RPM	Standard Pack	Item Number
							Brass
1-3/4"	.006	3/4"	1/4"	2-5/16"	13,000	10	14310
	.0118						14314
2-3/4"	.0118	7/8"	1/4"	2-1/2"	6,000	1	14311

• Non-stock product, contact Customer Service for lead times and minimum order quantities.



14314

P **KNOT WIRE END BRUSH** features a hollow end and heavy-duty brushing action with some flexibility; ideal for more demanding cleaning applications in recessed areas.



Diameter	Wire Size	Trim Length	Stem Diameter	Overall Length	Max. RPM	Standard Pack	Item Number
							Bronze
1-1/8"	.020	7/8"	1/4"	2-5/8"	22,000	10	10067



10067

P **CRIMPED WIRE END BRUSHES** feature a solid end and very flexible brushing action ideal for light-duty cleaning applications in corners and hard-to-reach areas.



Diameter	Wire Size	Trim Length	Stem Diameter	Overall Length	Max. RPM	Standard Pack	Item Number
							Brass
1/2"	.005	7/8"	1/4"	2-9/16"	25,000	10	10158
1"	.005	7/8"	1/4"	2-5/8"	20,000	10	10128
1"	.0118	1"	1/4"	2-5/8"	22,000	10	10091



10158

P **DOUBLE STEM, DOUBLE SPIRAL POWER TUBE BRUSHES** - Constructed with four stem wires and a double spiral of straight wire fill material to provide a more aggressive internal cleaning action.



Diameter	Wire Size	Brush Part	Stem Diameter	Overall Length	Standard Pack	Item Number
						Brass
1/2"	.006	2"	5/32"	5"	10	21178
5/8"	.008	2"	7/32"	5"	10	21219
3/4"	.006	2-1/2"	1/4"	5-1/2"	10	21179
1"	.006	2-1/2"	1/4"	5-1/2"	10	21218



21178

P **ROUND POWER TUBE BRUSHES** feature a single continuous length of stainless steel stem wire and a single spiral of crimped wire fill for a more flexible brushing action; suitable for use on smooth or threaded blind holes.



Diameter	Wire Size	Brush Part	Stem Diameter	Overall Length	Standard Pack	Item Number
						Brass
1/4"	.004	1"	1/8"	3-1/2"	10	21332
1/2"	.005	1"	3/16"	3-1/2"	10	21182
1-1/2"	.008	1"	1/4"	3-1/2"	10	21152



21332

P **SINGLE STEM, SINGLE SPIRAL HAND TUBE BRUSHES** - Constructed using a single continuous length of galvanized steel stem wire and feature a formed eye loop for convenient hand use. The single spiral of straight wire fill allows for easy manual insertion into the ID.

Diameter	Wire Size	Brush Part	Stem Diameter	Overall Length	Standard Pack	Item Number
						Brass
3/16"	.003	1-1/2"	3/32"	7"	10	21221
1/4"	.003	1-1/2"	3/32"	7"	10	21270
	.005					21139
3/8"	.004	2"	1/8"	8"	10	21191
1/2"	.004	2"	1/8"	8"	10	21165



21191

WHY WEILER
BONDED ABRASIVES
COATED ABRASIVES
NON-WOVEN ABRASIVES
POWER BRUSHES
NIXLOX BRUSHES
PACKAGED ITEMS
MAINTENANCE

WIDE FACE BRUSHES



Removing light corrosion and mill scale from coiled steel.



Cylindrical brush assemblies have proven to be reliable and economical tools for a wide variety of industrial surface conditioning applications. In addition to gang-mounting a series of individual wheel brushes onto a shaft or reusable arbor, one-piece wide face brush units can be manufactured to cover broad surfaces or provide maximum brushing action in a minimum amount of space.

Cylindrical brushes can be manufactured using several different styles of construction, and the characteristics of each style of construction can significantly affect brush performance. Weiler will custom-design a wide face brush in the most appropriate type of construction for your specific application. For more information and to schedule a consultation with a Weiler Process Solutions expert visit: weilerabrasives.com/wps.

APPLICATIONS

- Scrubbing debris from the surface of material during processing
- Removing corrosion, surface contamination, mill scale, or heat discoloration
- Roughening surfaces to promote adhesion or bonding
- Removing applied finishes and coatings
- Producing decorative surface finishes
- Deburring or finishing cylindrical parts
- Deburring the cut ends of tubing and extrusions

DISPOSABLE BRUSH ASSEMBLIES - Wide face assemblies for brushing flat surfaces can be manufactured as disposable units with a variety of available fill materials depending on the specific application. Available fills include; metallic filaments such as steel, stainless steel, or brass crimped wire; Nylox® nylon abrasive filaments; synthetic filaments such as nylon or heat-stabilized polypropylene; or natural fibers such as tampico.

Disposable mountings can be constructed of carbon steel or stainless steel components, and “flow-through” mountings which allow coolant to be circulated through the core and out the face of the brush are available for wet applications.

REFILLABLE BRUSH ASSEMBLIES - Wide face assemblies for brushing flat surfaces can also be manufactured as a replaceable brush unit wound onto a permanent and reusable arbor. Depending on the specific application and production environment, refilling reusable arbors may be a more economical option than using disposable units. Reusable mountings can be designed by Weiler or supplied by the customer.

In addition to the secondary operations such as nibbling and grinding of the brush face and dynamic balancing of the completed unit, Weiler also offers maintenance services on mounting hardware like collars and bearings.

TUBE END DEBURRING BRUSHES - Cylindrical rotary brushes are an ideal media for production applications involving the batch deburring of the ends of tubing that has been cut-to-length. Automated brushing systems are readily available and considerably less expensive to purchase and operate than chamfering machines.

Brush deburring machines can be integrated with cut-off operations to eliminate work-in-process and increase throughput, and they are flexible enough to be quickly adjusted for various shapes, sizes, and lengths of tubing. Unlike chamfering operations, brush deburring does not leave secondary burrs, brushing equipment is more tolerant of slight variations in machine set-up and tube length, and quality brushes last much longer than cutting inserts on double-end finishers.

Tube end deburring brushes are most commonly manufactured as disposable assemblies that are then mounted onto keyed shafts. High-tensile steel, hard-drawn steel, and Type 302 stainless steel wire are the most common fill materials used in tube end deburring brushes. Weiler offers high quality brushes with wire sizes from .006 to .020 and four available levels of fill density so that the brushing performance can be tailored to the material, burr condition, and budget of the end-user.

CUSTOM TUBE END DEBURRING BRUSHES - Please use the appropriate specification sheet on the next page when requesting a quotation on a custom tube end deburring brush.

NEED HELP?

For more information and to schedule a consultation with a Weiler Process Solutions expert visit: weilerabrasives.com/wps. To discuss specific requirements with a specialist call: 800-835.9999.

BRUSH-TUBE ORIENTATION

Brush-tube orientation determines which edges of the tube are deburred. The illustrations below show three orientations and the target edge.

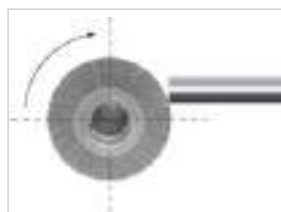

Deburring Tube I.D.

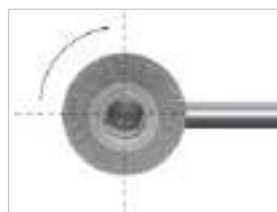

Deburring Tube I.D. and O.D.

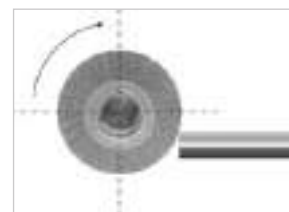

Deburring Tube O.D.

WIDE FACE BRUSH SPECIFICATION SHEET:

To help us accurately quote a wide face brush for your application, please provide the following information:

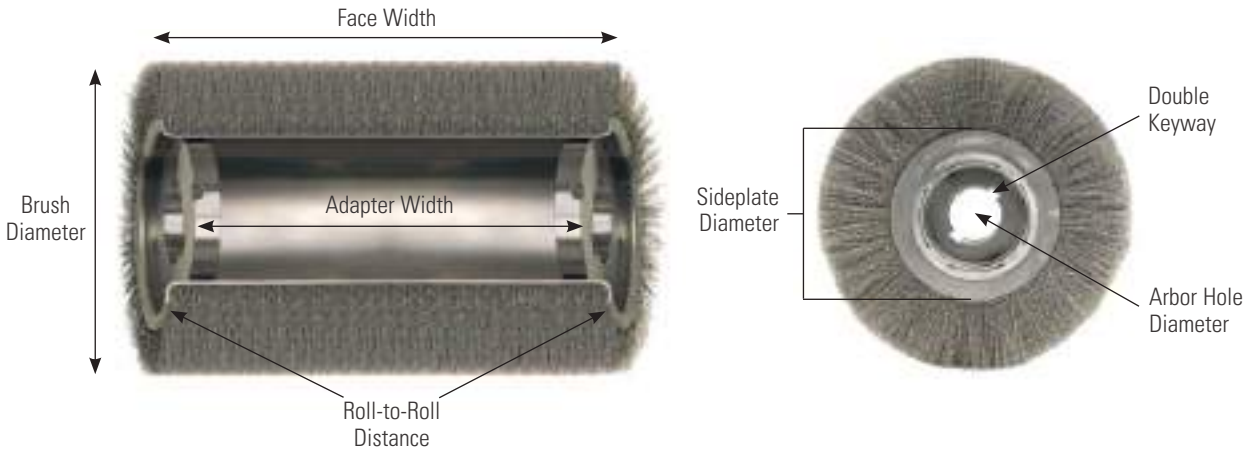

_____ Brush Diameter (Note: Tolerance is +/- 1/16")

_____ Fill Material _____ Fill Diameter

Fill Density: Economy General Purpose Heavy-Duty High Performance

_____ Face Width (Note: Tolerance is +/- 1/4")

_____ Roll-to-Roll Distance - Through Arbor Dimension (Note: Tolerance is +/- 1/8")

Brush can be manufactured holding the face width dimension or the roll-to-roll distance, not both.

_____ Sideplate Diameter

Standard sizes:

6" brush = 3-3/4" O.D.

8" brush = 5-1/4", 5-1/2" or 6-1/2" O.D.

>8" brush = 5-1/2" or 6-1/2" O.D.

_____ Maximum Operating RPM

_____ Adapter Width (Note: Adapters are 1/2" thick, tolerance on width spacing is +/- 1/8")

_____ Arbor Hole Diameter (Note: Clearance of 0.003" with additional tolerance of + 0.004" - 0 will be added)

Keyway(s) Required Single Double Keyway Width _____ Keyway Depth _____

Intended Brush Use: _____

Name: _____

End-User Name: _____

Company Name: _____

City: _____

Address: _____

State: _____ Zip: _____

Phone: (_____) _____

Fax: (_____) _____

E-mail: _____

FOR ADDITIONAL INFORMATION CALL:

To discuss specific requirements with a specialist call: 800-835.9999

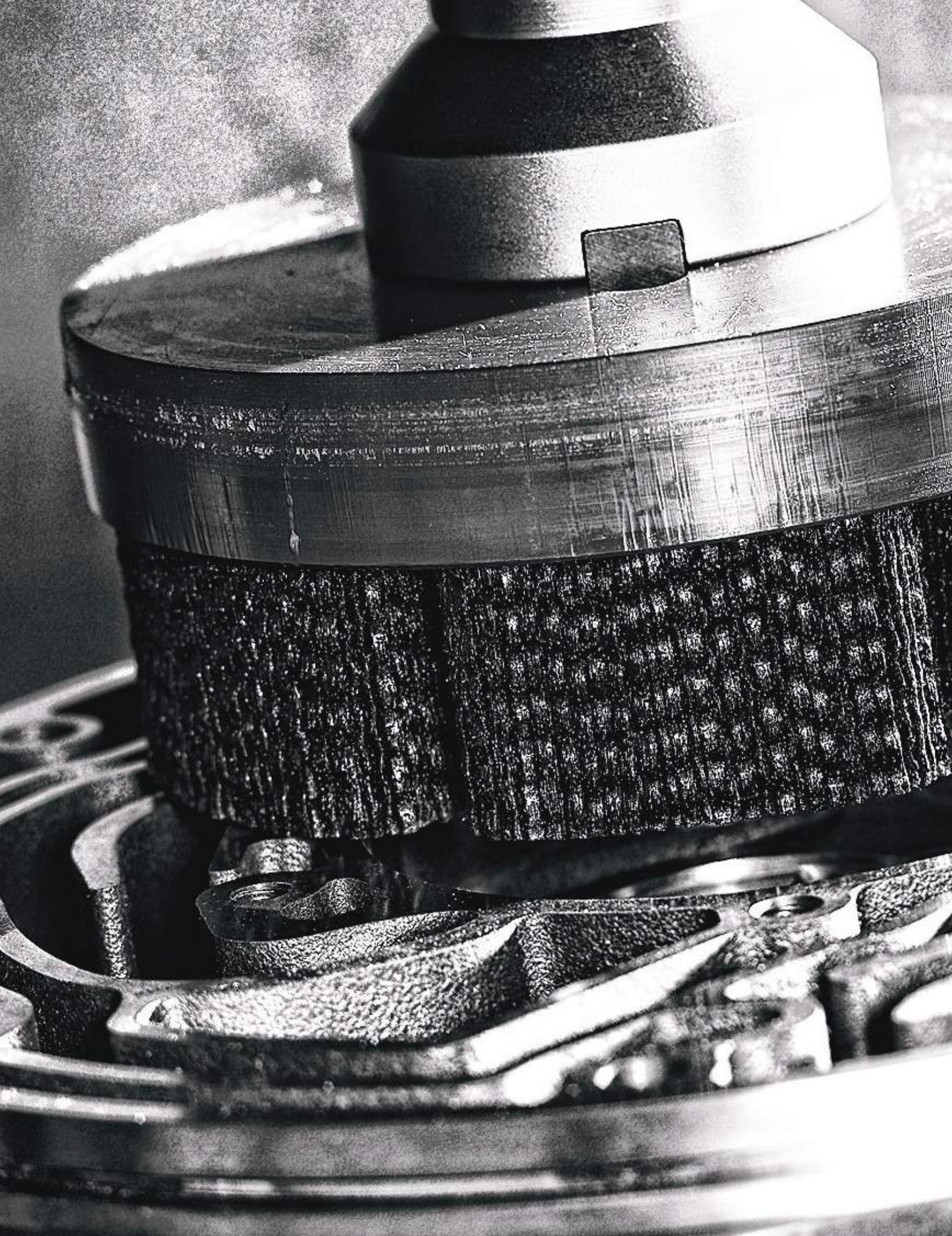

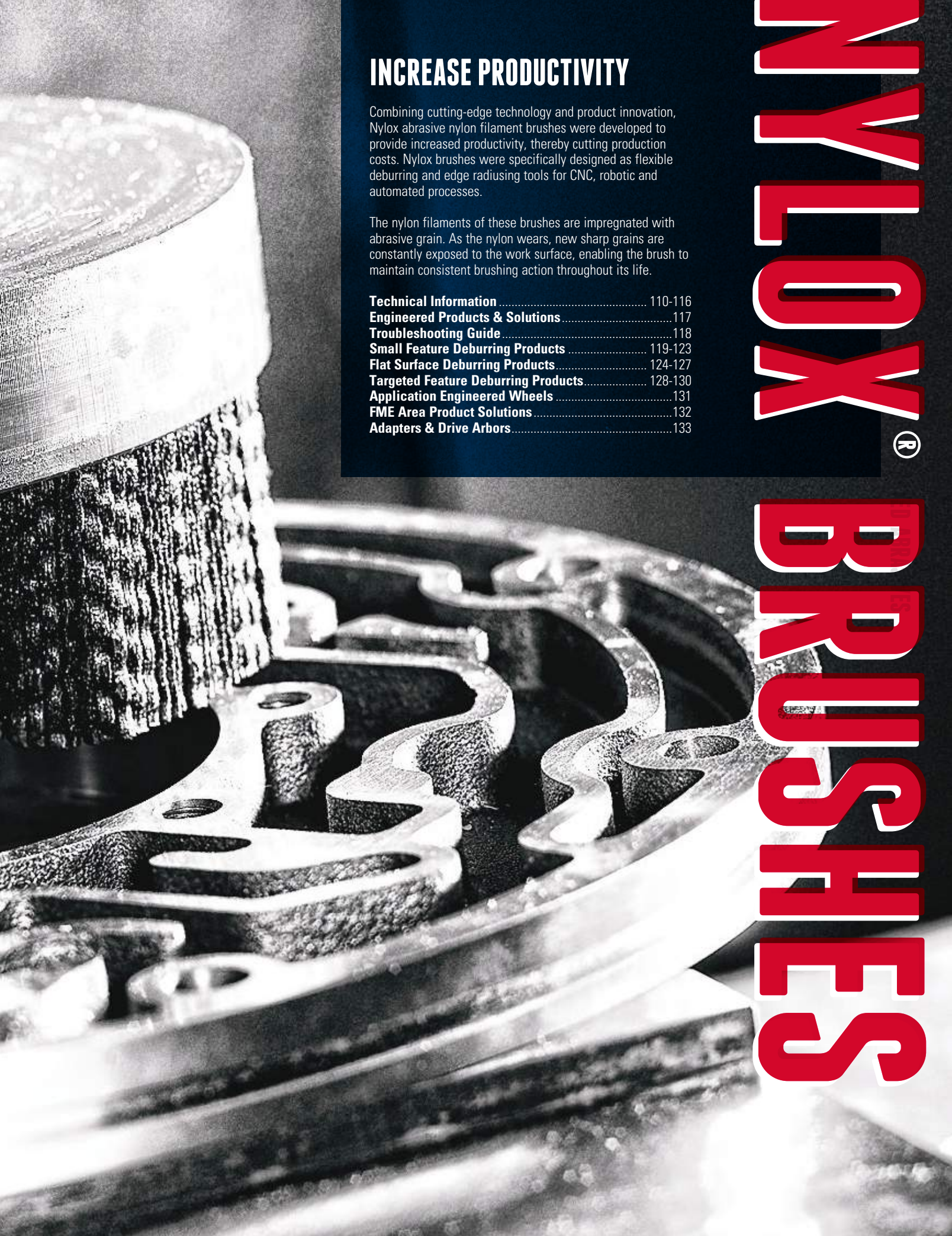

INCREASE PRODUCTIVITY

Combining cutting-edge technology and product innovation, Nylox abrasive nylon filament brushes were developed to provide increased productivity, thereby cutting production costs. Nylox brushes were specifically designed as flexible deburring and edge radiusing tools for CNC, robotic and automated processes.

The nylon filaments of these brushes are impregnated with abrasive grain. As the nylon wears, new sharp grains are constantly exposed to the work surface, enabling the brush to maintain consistent brushing action throughout its life.

Technical Information	110-116
Engineered Products & Solutions	117
Troubleshooting Guide	118
Small Feature Deburring Products	119-123
Flat Surface Deburring Products	124-127
Targeted Feature Deburring Products	128-130
Application Engineered Wheels	131
FME Area Product Solutions	132
Adapters & Drive Arbors	133

MYLOX[®]

BRUSHES

SOLUTIONS SHOWCASE

TRANSMISSION VALVE BODY

Problem: Burrs on transmission components can break away from parent components during use and cause transmission wear and eventual failure. Therefore, fluid passages must be completely burr-free.

Solution: A 10" Nylox® disc brush operating at 825 RPM in a vertical CNC machining center is an ideal solution for deburring this component. Since all of the burrs are on a single plane, the non-directional nature of a Nylox disc brush produces a part on which all edges have been uniformly deburred.



STEERING COMPONENT

Problem: Manual deburring can be costly in many respects. Hard deburring tools and aggressive abrasive wheels do not allow much margin for operator error and the result is often high scrap rates.

Solution: Nylox brushes produce a flexible filing action that concentrates all of the abrasive cutting action on sharp edges, giving them the ability to remove burrs without altering overall part dimensions. For example, a 6" Burr-Rx® wheel mounted onto a 1,725 RPM pedestal buffer is capable of deburring this steering component just as quickly as a convolute wheel but without the fear of over-radiusing the edges of the teeth or producing flat spots.



TOOL STEEL DEBURRING

Problem: Traditional nylon abrasive brushes were not sufficiently aggressive to remove large burrs from materials like tool steels and stainless steels.

Solution: Weiler's next generation filament technology, embodied in the company's line of Burr-Rx brushes, creates sufficient aggression to handle the toughest deburring jobs. This enables more users to capture the benefits offered by in-machine deburring.

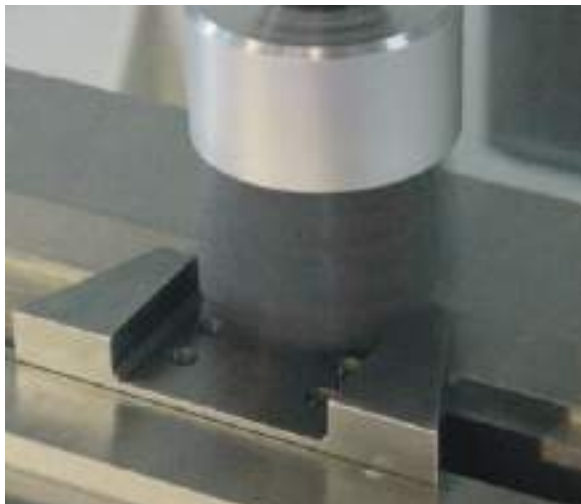

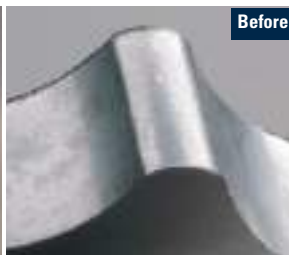
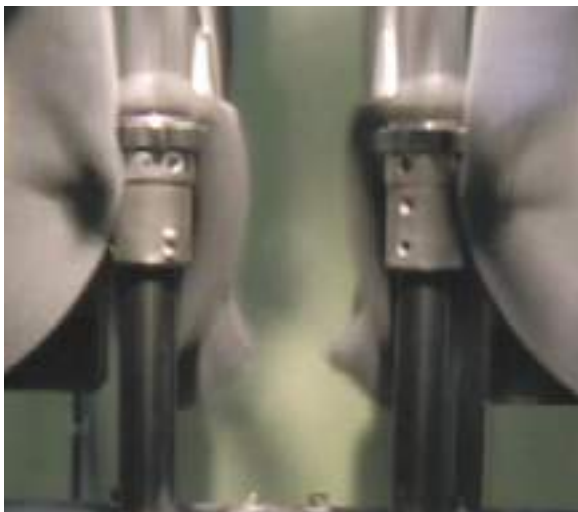

PUMP GEAR

Problem: Pumps are extremely susceptible to failure due to burrs. Due to the tight fit between components, all edges must be deburred and radiused to ensure proper function. Proper deburring of rotating pump gears is especially important.

Solution: A dedicated machine running 14" Nylox® wheel brushes at 900 RPM was a low-cost solution for deburring these gears. By using dedicated equipment, cycle time was minimized and an acceptable edge condition was achieved.



CAST ALUMINUM HOUSING

Problem: Although deburring the face-milled surfaces of castings is a very straight forward application for Nylox disc brushes, the limited availability of valuable machine time can be a perceived obstacle that prevents users from reaping the many benefits of implementing in-machine deburring operations.

Solution: The advanced ceramic grain technology of Weiler's Burr-Rx® tools offer a deburring action that is up to 400% greater than traditional abrasive nylon brushes that contain silicon carbide or aluminum oxide filaments. This allows Burr-Rx deburring tools to be used at feed rates that dramatically reduce the amount of additional machine time required to perform a brushing operation.

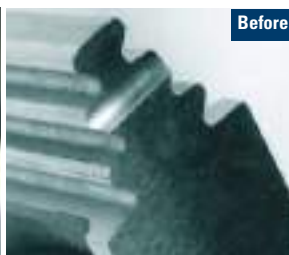
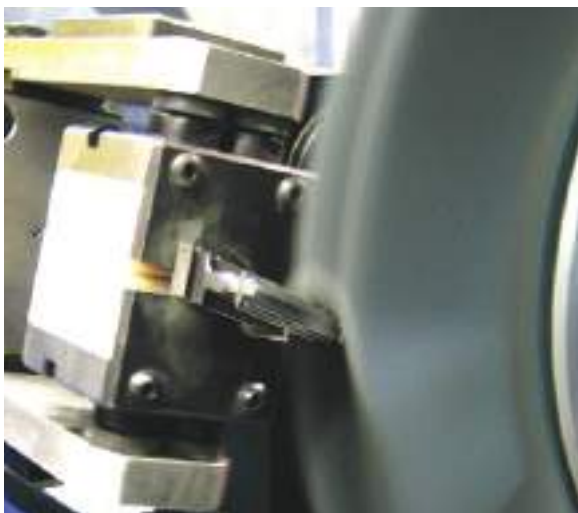

TURBINE BLADE

Problem: Protecting turbine engine components against high-temperature fatigue is critical to ensure safe, reliable engine operation. Component edges must be burr-free and generally require an edge radius in the range of 0.005" to 0.060".

Solution: Robots are extremely well-suited for this application because they can manipulate the component in many orientations in relation to the brush. Weiler works closely with users and robot integrators to develop products and process programs that maximize brush life while generating exceptional part quality and consistency.

Photo courtesy of ACME Manufacturing.

SELECTING THE RIGHT BRUSH



WHERE TO START?

Sometimes it's necessary to design and manufacture a unique, custom-tailored product to meet your application requirements. Although Weiler offers such engineered solutions in all of our product lines, the innovative construction and value-added nature of the Nylox® line of nylon abrasive filament brushes showcases the creativity and expertise of our Application Engineering Team in designing products that have been tailored to the needs of the customer.

- Custom-engineered Nylox brushes can be designed and manufactured as variations on our standard products.
- Wide face brush assemblies for finishing flat surfaces or deburring cylindrical parts can also be designed and manufactured using Nylox nylon abrasive filaments. (See pages 100-101 for more information)

FOR SOLUTIONS TO DIFFICULT APPLICATIONS

If the problem is too complex to be solved over the phone, we will determine if an evaluation should be conducted at our in-house lab or the user's facility.

For more information and to schedule a consultation with a Weiler Process Solutions expert visit: weilerabrasives.com/wps. To discuss specific requirements with a specialist call: 800-835.9999.

TRIM LENGTH AND FILL DENSITY

To maximize brush life and reduce costs, always use the shortest trim, highest density brush that will adequately conform to the surface or part edges.

LONG TRIM, LOW DENSITY



These brushes offer a greater degree of flexibility that is ideal for applications requiring a high degree of brush conformability. However, the lower fill density can result in shorter brush life and less consistent performance.

SHORT TRIM, HIGH DENSITY



These brushes work with a faster action and less engagement with the brush face. This produces shorter cycle times, more consistent performance and longer life in applications that do not require a high degree of brush conformability.

GRIT SIZE COLORS

Grit size is indicated by a dot on the product with the following colors:

Black 46 Grit	Green 120 Grit	Gold 200 Grit	Purple 600 Grit
Red 60 Grit	Grey 180 Grit	White 320 Grit	Blue 1000 Grit
Yellow 80 Grit	Orange 240 Grit	Brown 500 Grit	Lt. Blue 800 Grit
			Pink 1200 Grit

PRODUCT ADVANTAGES

PRODUCT ADVANTAGES

AGGRESSIVE YET COMPLIANT



- Nylox® brushes do not alter the overall dimensions or geometry of a part.
- Filament compliance allows these brushes to conform to complex part shapes and reduces the need for ultra-precise programming and fixturing.

IDEAL FOR AUTOMATION



- Abrasive grain is evenly distributed throughout the nylon filament.
- Extremely consistent performance throughout their product life.
- Ideal media for use in automated deburring and finishing processes.
- Ideal for dedicated production equipment or robotic cells.
- Can be directly integrated into the cycle of CNC machining centers.
- Improve part quality and consistency.
- Reduce direct labor cost.

IDEAL FOR DEBURRING



- Nylox filaments act like flexible files, deburring and radiusing edges as they wipe across them.
- Their limited aggression and flexible filing action also make them suitable for deburring a wider range of materials in comparison to wire-filled power brushes.

ENHANCED SURFACE FINISHES



- The compliant cutting action not only limits their ability to alter part dimensions, but it makes them an effective tool for refining surface texture characteristics without removing significant amounts of base material.
- Although they contain the same abrasive grain sizes, Nylox brushes will not generate the same prominent scratch pattern as a comparable coated abrasive product.

CONSTRUCTION ADVANTAGES

COMPETITOR'S METAL HUB

- Metal hub components are assembled under high pressure, potentially damaging the filaments and causing premature breakage.
- Retaining ring displaces filament material, creating a void in the center of the brush face.
- Lower fill density can result in shorter life and less consistent performance.



WEILER'S COMPOSITE HUB

- Molded hub construction eliminates filament breakage.
- Uniform distribution of fill material and superior balance.
- Higher fill density provides more aggressive brushing and longer life.
- Consistent performance as the brush wears.



WEILER'S COMPOSITE METAL HUB

- Filaments retained using the latest polymer technology to prevent filament breakage.
- Metal components add impact resistance and dimensional stability.
- The highest filament density in the market ensures lowest cost-per-part.



WEILER'S PVC SHELL MILL

The PVC construction results in a very consistent, flat brush face. Their high dimensional precision makes them suitable for the most critical applications. They perform more consistently from the first part to the last.



WEILER'S TUFTED FILAMENTS

This construction style offers increased aggression due to added filament density. This enables processing of severe burrs or generating larger edge radii in shorter cycle times. The longer trim length allows for greater conformability and longer life.



WEILER'S MAXIMUM DENSITY

Maximum density brushes are uniquely suited for demanding applications characterized by large burrs and rapid feed rates.



WHY WEILER

BONDED ABRASIVES

COATED ABRASIVES

NON-WOVEN ABRASIVES

POWER BRUSHES

NYLOX BRUSHES

PACKAGED ITEMS

MAINTENANCE

PRODUCT CHARACTERISTICS

WHEEL BRUSHES



- Precision deburring of component parts after machining or grinding.
- Improving surface texture on machined or ground surfaces.
- Honing cutting tools and generating specific edge profiles and radii.
- Light duty cleaning and finishing of metals; light sanding of woods and composites.



DISC BRUSHES



- Deburring flat surfaces on machined components.
- Improving texture on machined or ground surfaces.
- Deburring face-milled castings or forgings.
- Blending tool marks after machining or grinding.



END BRUSHES



- Deburring flat surfaces on machined components.
- Improving texture on machined or ground surfaces.
- Deburring face-milled castings or forgings.
- Blending tool marks after machining or grinding.



TUBE BRUSHES

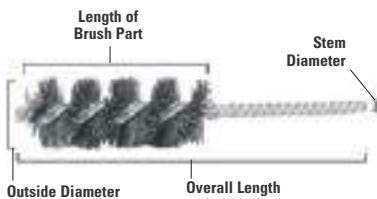

- Deburring and finishing applications in tubular component parts, drilled and tapered holes and machined bores and passages.



CROSSHOLE DEBURRING BRUSHES

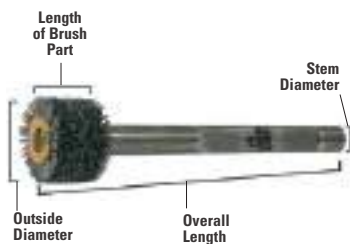

- Deburring internal edges.
- Improving surface texture on internal bores.



FILAMENT CONFIGURATIONS

ROUND FILAMENTS - Due to their cross-sectional shape and the reduced contact with the work surface or part edges that result, round filaments provide a more compliant brushing action for less aggression and enhanced conformability.

RECTANGULAR FILAMENTS - Due to their shape, larger cross-sectional area and increased contact with the work, rectangular filaments provide a less compliant brushing action for much greater aggression and reduced conformability.

Crimping either type of filament along its length enhances conformability, allowing greater penetration of part edges into the brush face, often increases aggression. Crimped filaments are especially beneficial in maximum density disc brush designs.

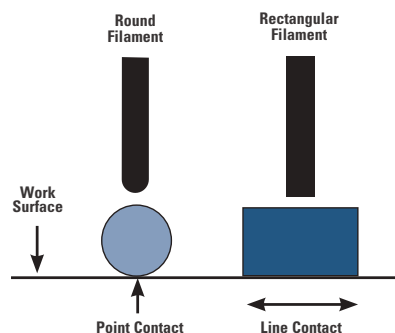

ABRASIVE FILAMENTS

Abrasive brush filaments are manufactured by extruding a mixture of liquefied polymer and abrasive grain. Unlike the filaments used in DIY grade abrasive brushes, industrial grade products like Weiler's Nylox® and Burr-Rx® brushes feature the highest grade of abrasive filament manufactured using a Type 6.12 nylon polymer. Industrial grade filaments also feature the highest quality abrasive materials that have been sifted and sorted to ensure that the grains are consistent in size. These grains may be one of four different types of abrasive:

- **ALUMINUM OXIDE (AO)** - is a duller, less aggressive grain typically used in finishing applications requiring a less pronounced scratch line pattern or deburring applications on materials where the use of SiC may be prohibited
- **SILICON CARBIDE (SIC)** is a sharp-edged grain that produces an effective cutting action. It is the most common grain used in industrial grade brushes.
- **BURR-RX CERAMIC (CG)** is an engineered abrasive grain that produces a superior cutting action and is compatible with the widest range of materials. It is the most effective grain available today!
- **DIAMOND FILAMENT** is a sharp-edged grain typically used for producing edge radii on hard materials like diamond, ceramic, CBN and glass.

ADVANTAGES OF BURR-RX® CERAMIC

Nylox brushes containing the Burr-Rx black ceramic filament provide the following advantages over SiC and AO filaments.

- 400% greater cutting action
- Most cost-effective deburring brush
- Deburr tougher materials
- Minimize cycle time
- Maximize tool life
- Reduce finishing costs
- Eliminate hand deburring

DEBURRING ACTION - BURR-RX (CG VS. SIC)

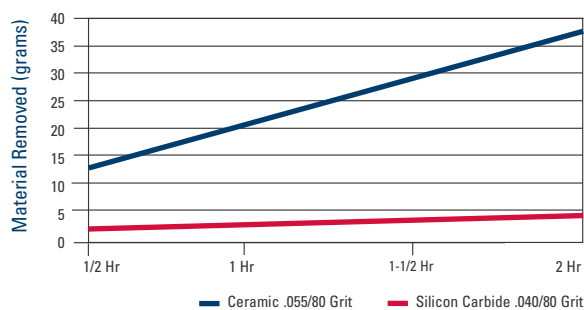

WHEEL VS. DISC BRUSH



Nylox wheel brushes are for applications where a targeted brushing action is required.



Disc brushes are for applications where the burrs lie along a single plane.

OPERATING INFORMATION

OPERATING PARAMETERS

Nylox® abrasive brushes work with a wiping and filing action. Think of them as flexible files. The sides of the Nylox filament actually do the work. To achieve a maximum edge radius and complete burr removal, parts should be buried into a slow running brush face. They work best when operated at speeds that allow fairly deep penetration of the work-

piece into the brush filaments. Usually, faster speeds do not work as well as slower speeds. The maximum RPM marked on the brush is not the optimum working speed. A good rule of thumb is to stay under 2,500 SFPM in dry applications and 3,500 SFPM in wet applications.

WHEEL BRUSHES PENETRATE 10% OF TRIM LENGTH



DISC BRUSHES 0.075" - 0.100" DEPTH OF INTERFERENCE



OPERATING SPEEDS - WHEEL BRUSHES

Diameter	RPM
2"	3,450 - 5,000
3"	2,500 - 3,450
4"	1,750 - 2,500
6"	1,350 - 1,750
8"	1,150 - 1,350
10"	950 - 1,150
12"	750 - 950
14"	650 - 850

OPERATING SPEEDS - DISC BRUSHES

Diameter	RPM
1-3/4" & 2"	1,750 - 2,000
3"-4"	1,500 - 1,750
5" - 6"	1,250 - 1,500
8"	800 - 1,000
10"	700 - 800
12"	600 - 700
14"	500 - 600

FEED RATE is determined by the amount of deburring, edge radiusing or surface finishing required and the type of material that is being processed. It is generally application specific. Slower feeds result in a more aggressive brushing action. Based on the brushing action desired for a specific application, the feed rate can be increased or decreased.

Material	SiC and AO Grain Feed Rate	Burr-Rx Grain Feed Rate
Non-Ferrous	50 in./min.	80 in./min.
Cast Iron	30 in./min.	60 in./min.
Mild Steel and Ductile Iron	25 in./min.	50 in./min.
Stainless and Alloy Steels	15 in./min.	30 in./min.
Titanium and High Nickel Alloys	10 in./min.	30 in./min.

RECOMMENDED MOTOR SIZES

Brush Diameter	Motor Size	RPM*
3"-4"	1/4 HP	3,450
6"	1/2 HP	1,725
8"	3/4 HP	1,725
10"	1 HP	1,140
12"	1 HP	1,140
14"	1-1/2 HP	900

Note: This chart is based on 1" brush face.

* A variable-speed motor control may be required to achieve optimum operating RPM; see operating speed charts above.

MINIMUM RECOMMENDED SPINDLE DIAMETER (from ANSI Standard B165.1)

Outside Dia. of Wheel Brush	Maximum Face Width of Wheel Brush	Minimum Outside Dia. of Spindle (Shaft)
2"	1/4"	1/4"
3"	3/4"	1/4"
3" (heavy-duty)	1"	3/8"
4"	1"	3/8"
6"	1-1/4"	1/2"
8"	1-1/4"	5/8"
10"	2"	3/4"
12"	3"	1"
14"	3"	1-1/4"
15"	3"	2"
16"	3"	2"

Note: These diameters are based on the wheel brush being mounted next to the supported end of the shaft rather than the unsupported end in order to minimize overhang.

COOLANT & WEAR COMPENSATION

COOLANTS

Nylox® brushes can be run dry, without coolants. However, certain deburring conditions such as higher speeds, material properties and greater depth of penetration can create excessive heat buildup, causing the nylon filaments to melt and smear on the work surface. If the speed or depth of penetration cannot be changed, coolants are recommended to overcome heat smear. Coolants will also help produce finer finishes.

WEAR COMPENSATION

On dedicated equipment, it is possible to automate wear compensation by using electronic controls to monitor the load on drive motors and adjust the position of the brushing tool to maintain a relatively consistent amount of interference or pressure. Since this is typically not possible with standard CNC machine tools, there are three other possible methods of compensating for tool wear for "in-machine" implementations of Nylox brushes.

AUTOMATIC INDEXING

Most CNC controllers allow tool wear compensation to be accomplished by

programming a "macro" - routine to periodically adjust the position of the tool based upon the number of parts produced. Some experimentation may be required to determine the frequency and amount of adjustment that will result for most consistent performance and maximum brush life.

PROBING

If the machining center has the capability to probe the face of the brush, this feature can be used to gauge the true position of the filament tips. Adjustments to the brush position can then be made to maintain a consistent amount of interference between the tool and the part.

MANUAL

If the other methods cannot possibly be used, machine operators can adjust the brush position based on either statistical process control data or visual inspection of completed parts.

THE IDEAL TOOL PATH for a Nylox Disc brush is very similar to the path of the face mill that produced the burr. However, three differences exist:

- The rotation direction of the brush should be opposite of the cutting tool that created the burr.
- The length of the path must be longer than the part. Unlike a cutter path that can stop when the leading edge of the cutter reaches the end of the part, the tool path of a brush should continue until the trailing edge of the brush reaches the end of the part.
- The centerline of the brush may need to be off-set from the center of the part in order to maximize the number of filaments that strike the part at a perpendicular angle. This is especially important when the diameter of the brush is similar to the width of the part.

The part is deburred in the shortest cycle time with the lowest consumable cost-per-part.

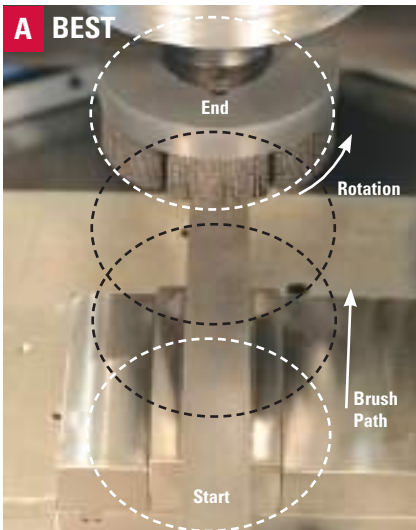

If a large diameter brush can be used, the centerline of the brush should be positioned on the center of the part. Ideally, the brush should be 3-4" wider than the part.

The part is deburred, but requires a longer cycle time. When a large brush will not fit in the tool changer, this method is recommended.

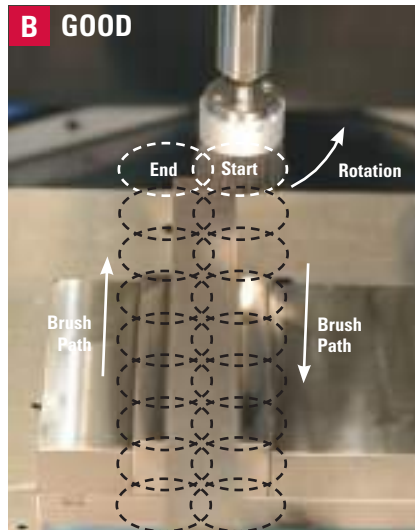

If a small diameter brush must be used, the centerline of the brush should be positioned on the edge of the part. This maximizes aggression by increasing the amount of perpendicular contact between the brush filaments and the burred edge.

Produces less deburring than A & B.

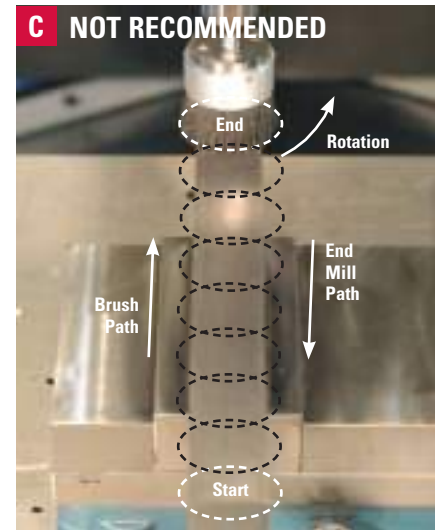

Positioning a small diameter brush with its centerline on the center of the part is not recommended. This configuration will not allow perpendicular contact of the filaments against the burred edge.

COOLANT COMPATIBILITY



NYLOX® BRUSHES IN AUTOMATED ENVIRONMENTS

MYTH:

The abrasive grain in the Nylox brush will affect the accuracy of the equipment over time.

FACT:

The abrasive grain in the Nylox brushes will not result in accelerated machine wear over time when used with proper filtration (50-micron or finer).



Automotive Case Study

In the auto industry a five year study was conducted on the use of Weiler Nylox brushes with silicon carbide (SiC) grain in the manufacturing of aluminum intake and exhaust manifolds. Over the period of the study, there was no noticeable difference in way wear between machines that ran brushes and those that did not. A 50-micron coolant filter worked as specified to remove the residuals from the brushing process.

Aerospace Case Study

A three year study was conducted on the use of Weiler Nylox brushes with ceramic grain (CG) in the manufacture of jet engine components. Over the period of the study, there was no loss in accuracy in the aerospace manufacturer's machines. A 50-micron coolant filter worked as specified to remove the residuals from the brushing process.

ENGINEERED PRODUCTS AND CUSTOMIZED SOLUTIONS



Two members of our Application Engineering Team discuss the results after testing an engineered product.

WE PROVIDE YOU WITH THE MOST COST-EFFECTIVE APPLICATION SOLUTIONS

Sometimes it is necessary to design and manufacture a unique, custom tailored product to meet your application requirements. Although Weiler offers such engineered solutions in all of our product lines, the innovative construction and value-added nature of the Nylox® line of nylon abrasive filament brushes showcases the creativity and expertise of our Application Engineering Team in designing products that have been tailored to the needs of the customer.

- Custom-engineered Nylox brushes can be designed and manufactured as variations on standard product configurations such as wheel, disc, cup, end, or tube brushes.
- Weiler's exclusive Burr-Rx® and Bore-Rx™ brushing tools can be engineered to meet the demands of a specific application.
- Wide face brush assemblies for applications such as finishing flat surfaces or deburring cylindrical parts can also be designed and manufactured using Nylox nylon abrasive filaments. (See pages 104-105 for more information)

FOR SOLUTIONS TO DIFFICULT APPLICATIONS

If the problem is too complex to be solved over the phone, we will determine if an evaluation should be conducted at our in-house lab or the user's facility.

For more information and to schedule a consultation with a Weiler Process Solutions expert visit: weilerabrasives.com/wps. To discuss specific requirements with a specialist call: 800-835.9999.



TROUBLESHOOTING GUIDE

There are many variables in Nylox® applications. If the Nylox brush you are using does not accomplish the desired results, select a solution from the suggestions below for your specific application.

Problem	Recommended Solutions
Brush not aggressive enough	<ul style="list-style-type: none"> • Increase filament diameter and/or grit size • Increase filament density by using round straight rather than round crimped • Increase surface contact by using rectangular rather than round • Increase pressure/depth of interference • Increase surface speed by increasing spindle RPM • Use a larger diameter brush • Reduce trim length or feed rate
Brush too aggressive	<ul style="list-style-type: none"> • Reduce filament diameter and/or grit size • Reduce filament density by using round crimped rather than round straight • Reduce surface contact by using round rather than rectangular • Reduce pressure/depth of interference • Reduce surface speed by reducing spindle RPM • Use a smaller diameter brush • Increase trim length or feed rate
Brush not conformable enough	<ul style="list-style-type: none"> • Increase trim length • Reduce filament diameter • Reduce filament density by using round crimped rather than round straight or rectangular • Reduce surface speed by reducing spindle RPM • Reduce feed rate
Finer final finish required	<ul style="list-style-type: none"> • Increase surface speed by increasing spindle RPM • Decrease grit size • Use brush with a coolant
Coarser final finish required	<ul style="list-style-type: none"> • Reduce surface speed by reducing spindle RPM • Increase grit size • Use brush without a coolant
Filaments melt/smear on workpiece	<ul style="list-style-type: none"> • Reduce surface speed by reducing spindle RPM • Use a smaller diameter brush • Use brush with a coolant
Short brush life	<ul style="list-style-type: none"> • Increase filament density • Reduce pressure/depth of interference

NEED HELP?

For more information and to schedule a consultation with a Weiler Process Solutions expert visit: weilerabrasives.com/wps.
To discuss specific requirements with a specialist call: 800-835.9999.

SMALL FEATURE DEBURRING PRODUCTS

SMALL DIAMETER WHEELS

Ideal for recesses and internal features or delivering targeted brushing action to a specific area. Our Burr-Rx® black ceramic grain filament wheels deliver up to a 400% greater edge-cutting action compared to traditional silicon carbide and aluminum oxide filaments for the fastest, most aggressive action for minimum cycle times and maximum life.

APPLICATIONS

- Deburring keyways, slots and crosshole intersections
- Honing and finishing of cylindrical bores

BURR-RX® SMALL DIAMETER WHEELS - Metal Hub - Crimped Round Black Ceramic Filament

Diameter	Filament Dia./Grit	Arbor Hole	Face Width	Trim Length	Max. RPM	Standard Pack	Item Number
1-1/2"	.026/120	1/2"	3/8"	1/4"	10,000	10	17541
2"	.026/120 .035/80	1/2"	3/8"	1/2"	10,000	10	17548 17555 •
3"	.026/120 .035/80 .043/120	1/2"	1/2"	1"	10,000	10	17565 17567 17568

Other diameters and grit sizes available upon request.



Deburring the edges of a machined aluminum component.



17568

SMALL DIAMETER WHEELS - Metal Hub - Crimped Round Silicon Carbide Filament

Diameter	Filament Dia./Grit	Arbor Hole	Face Width	Trim Length	Max. RPM	Standard Pack	Item Number
1-1/8"	.022/120	1/4"	5/16"	1/4"	10,000	10	17532 •
1-1/4"	.022/120	1/4"	5/16"	5/16"	10,000	10	17535
1-3/8"	.018/500	1/4"	5/16"	3/8"	10,000	10	16310*
2"	.018/500 .022/320 .040/120	1/2"	3/8"	1/2"	10,000	10	17533 17543 17633
2"	.022/120	5/8"	7/16"	7/16"	10,000	10	17629 •
2-1/2"	.022/320 .022/120	5/8"	1/2"	11/16"	10,000	10	29356 29123
3"	.022/320 .022/120 .040/120	1/2"	1/2"	1"	10,000	10	17563 16315 16263

Other diameters and grit sizes available upon request. Aluminum oxide*



17533

DRIVE ARBORS - For mounting small diameter wheels into a collet or chuck.



Arbor Diameter	Stem Diameter	Stem Length	Length of Shaft	For Brushes with Max. Dia. of	Overall Length	Max. RPM	Standard Pack	Item Number
Unthreaded Shaft								
1/4"	1/4"	1-1/8"	3/16"	2"	2-1/16"	20,000	5	07723
Threaded Shaft								
1/2"	1/4"	3/4"	3/4"	3"	1-3/4"	25,000	5	07724
5/8"	1/4"	3/4"	3/4"	3"	1-13/16"	25,000	5	07729
1/2"	1/4"	7/8"	3/4"	3"	1-11/16"	20,000	5	07721
1/4"	1/4"	1-1/16"	1-1/8"	2"	2-9/16"	20,000	5	07725



07723



07724



07729



07721



07725

PLASTIC ADAPTERS for mounting small diameter wheels onto various arbor sizes.

Fixed Arbor Hole Size	Adapted Arbor Hole Size	Standard Pack	Item Number
1/2"	1/4"	10	04400
1/2"	3/8"	10	04401
5/8"	1/2"	10	04402



04401

04402

NOTE

See adapters on page 133

• Non-stock product, contact Customer Service for lead times and minimum order quantities.

COATED ABRASIVES

NON-WOVEN ABRASIVES

POWER BRUSHES

NYLON BRUSHES

PACKAGED ITEMS

MAINTENANCE



END BRUSHES

Featuring an integral stem for convenient mounting into a tool holder or collet, Nylox® end brushes and miniature end brushes are suitable for addressing recesses and internal features, or delivering a targeted brushing action to a specific area on a part.

APPLICATIONS

- Deburring small recessed areas and internal part features
- Finishing slots and recessed surfaces on machined parts

Deburring small features on a powdered metal part.

BURR-RX® END BRUSHES - Banded - Crimped Round Black Ceramic Filament - Mounted on 1/4" Stems



Diameter	Filament Dia./Grit	Trim Length*	Recommended RPM	Overall Length	Max. RPM	Standard Pack	Item Number
3/8"	.043/120	1/4"	4,500 - 5,000	2-3/8"	10,000	10	86099
1/2"	.026/120	1/4"	4,500 - 5,000	2-7/16"	10,000	10	86100
	.043/120						86101
3/4"	.026/120	1/4"	4,200 - 5,000	2-7/16"	10,000	10	86102
	.043/120						86103
1"	.026/120	1/4"	3,500 - 3,800	2-5/8"	10,000	10	86104
	.043/120						86105
	.055/80						86097

* Trim length from bands

END BRUSHES - Banded - Crimped Round Silicon Carbide Filament - Mounted on 1/4" Stems



Diameter	Filament Dia./Grit	Trim Length*	Overall Length	Max. RPM	Standard Pack	Item Number
1/2"	.022/320	3/8"	2-9/16"	10,000	10	11160
	.035/180					11161
	.040/120					11162
3/4"	.035/180	3/8"	2-7/16"	10,000	10	11165
	.040/120					11166 •
1"	.035/180	3/8"	2-11/16"	10,000	10	11169
	.040/120					11170

* Trim length from bands

END BRUSHES - Crimped Round Silicon Carbide Filament - Mounted on 1/4" Stems



Diameter	Filament Dia./Grit	Trim Length	Overall Length	Max. RPM	Standard Pack	Item Number
3/4"	.022/320	7/8"	1-1/2"	10,000	10	10152
	.035/180					10153
	.040/120					10154
1"	.022/320	7/8"	2-3/4"	10,000	10	10155
	.035/180					10156
	.040/120					10157



MINIATURE END BRUSHES - Plastic Ferrule - Crimped Round Silicon Carbide Filament Mounted on 1/8" stems

Diameter	Filament Dia./Grit	Trim Length	Overall Length	Max. RPM	Standard Pack	Item Number
3/16"	.018/500	1/4"	1-7/8"	37,000	144	26136
1/4"	.018/500	3/8"	2-1/8"	37,000	144	26138
5/16"	.018/500	9/16"	2-11/32"	25,000	144	26146

MINI DISC BRUSHES

Featuring a precision machined aluminum cup, Weiler's mini-disc brushes are designed to be the most cost-effective media for applications requiring a smaller brushing tool.

APPLICATIONS

- Deburring flat surfaces on machined components
- Improving texture characteristics on machined or ground surfaces
- Deburring face-milled castings or forgings
- Blending tool marks after machining or grinding

BURR-RX® MINI DISC BRUSHES - Maximum Density - Crimped Black Ceramic Filament

Diameter	Filament Dia./Grit	Arbor Hole	Drive Arbor + Recommendation	Trim Length	Max. RPM	Standard Pack	Item Number
Round Filament							
2"	.026/120	3/8"	89029 or 89033	1-1/4"	4,500	2	86106
	.035/80					1	85738
	.043/120					2	86107
	.055/80					2	85733
3"	.026/120	3/8"	89029 or 89033	1-1/4"	4,500	1	86109
	.035/80						86013
	.043/120						86110
	.055/80						86111
Rectangular Filament							
2"	80	3/8"	89029 or 89033	1-1/4"	4,500	1	85736
3"	80	3/8"	89029 or 89033	1-1/4"	4,500	1	86014

+ See page 133 for drive arbor specifications.

MINI DISC BRUSHES - Silicon Carbide Filament

Diameter	Filament Dia./Grit	Arbor Hole	Drive Arbor + Recommendation	Trim Length	Max. RPM	Standard Pack	Item Number
Round Filament							
1-3/4"	.035/180 .040/80	5/8"	89023 • or 89024	1-1/4"	6,000	2	85753
							85750
Rectangular Filament							
1-3/4"	80	5/8"	89023 • or 89024	1-1/4"	6,000	2	85752 •
2"	80	3/8"	89029 or 89033	1-1/4"	4,500	2	85773*
3"	80	3/8"	89029 or 89033	1-1/4"	4,500	1	85981*

+ See page 133 for drive arbor specifications. • Maximum density • Non-stock product, contact Customer Service for lead times and minimum order quantities.



Deburring the machined face of an aluminum component.



85733



85752



85981



14413

CUP BRUSHES

Weiler also offers an assortment of Nylox® tools featuring traditional cup brush construction for deburring and finishing use in lighter duty applications. These brushing tools can be used on dedicated machines in automated processes or on low speed/high torque hand-held tools for manual applications.

APPLICATIONS

- Deburring and finishing complex or contoured parts

CUP BRUSHES - Crimped Round Silicon Carbide Filament

Diameter	Filament Dia./Grit	Arbor Hole	Trim Length	Max. RPM	Standard Pack	Item Number
2-3/4"	.022/320	1/4" Stem	1-1/4"	6,000	1	14401 •
	.035/180					14403 •
	.040/120					14404
3-1/2"	.035/180	5/8"-11	1-1/2"	12,000	1	14413
	.040/120					14414
5"	.040/120	5/8"-11	1-1/4"	9,000	1	14576
6"	.040/120 .040/80	5/8"-11	1-1/4"	6,600	1	14516*
						14506*

* With internal nut

• Non-stock product, contact Customer Service for lead times and minimum order quantities.



COATED ABRASIVES

NON-WOVEN ABRASIVES

POWER BRUSHES

NYLOX BRUSHES

PACKAGED ITEMS

MAINTENANCE

NOTE

See adapters on page 133



Deburring internal bores of a cylinder head.

BORE-RX™ CROSSHOLE DEBURRING BRUSHES

These brushes are designed for automated applications in CNC machining centers and dedicated machines. They are ideal for removing burrs from internal edges and finishing bores. Since they eliminate off-hand deburring, they improve part-to-part consistency and reduce direct labor content. Bore-Rx brushes are available in sizes ranging from 7/8" to 4" and can be readily adapted into a machining center's tool changer using an end-mill holder or 3/8" collet.

Operating Parameters For Bore-Rx Brushes

Brush Diameter	Recommended RPM	Recommended Feed Rate
5/8" - 7/8"	3000	20"/min
1" - 1-1/2"	3000	20"/min
2" - 2-1/2"	2000	20"/min
3" - 4"	1500	20"/min

Tool Paths for Crosshole Deburring

An effective tool path for most crosshole deburring jobs is circular interpolation using the following guidelines to determine diameter of interpolation. The interpolation should be performed at a depth where the center of the brush face is at the center of the intersecting hole.

Diameter of Interpolation = Hole Dia. - 0.975 x Brush Dia.

Tool Paths for Bore Finishing

Nylox® brushes can be used to improve the surface finish of bores. The best tool path normally involves helically interpolating the bore. The above recommendations for speed, feed and diameter of interpolation are also valid for bore finishing. The use of coolant is highly recommended in order to achieve maximum surface finish improvement.



86155



17208

BORE-RX® BRUSHES - 3/8" Stem - Crimped Round Black Ceramic Filament

Diameter	Filament Dia./Grit	Face Width	Trim Length	Overall Length	Max. RPM	Standard Pack	Item Number
7/8"	.026"/120	3/4"	.160"	4-3/4"	8,000	1	17206 •
1"	.026"/120	3/4"	.215"	4-3/4"	8,000	1	17208
1-1/4"	.026"/120	3/4"	.345"	4-3/4"	8,000	1	17210
1-1/2"	.026"/120	1"	.475"	5"	8,000	1	17212
2"	.026"/120	1"	.535"	3-1/4"	6,000	1	17215
3"	.043/120 .055/80	1"	.560"	3-1/4"	6,000	1	86151 • 86152
4"	.026/120 .043/120 .055/80	1"	1.040"	3-1/4"	6,000	1	86154 • 86155 86156

Note: All Bore-Rx brush stems have a 2" long flat for use in end mill holders. Alternatively, they can be mounted in 3/8" collets.

CUSTOMIZABLE CROSSHOLE DEBURRING SOLUTIONS

Replacement Bore-Rx Brush Heads and Reusable Bore-Rx Arbors

In high production applications, reusable arbors reduce manufacturing costs by allowing the use of inexpensive brush head replacements. Brush heads are made-to-order in diameters ranging from 7/8" to 1-1/2" with face widths of 1/4" to 1". They are available on 3/16" and 1/4" pins. The pin diameter is based on the application and determines brush density. To discuss specific requirements with a specialist call: 800-835.9999.



Replacement Head



8" Overall Length Reuseable Extension 03991 •



3-1/2" Reuseable Arbor 03993 • for Replacement Heads

• Non-stock product, contact Customer Service for lead times.

TUBE BRUSHES

Nylox® power tube brushes are ideal for internal deburring and finishing applications in tubular component parts, drilled and tapered holes, and machined bores and passages. These brushes are suitable for use in drill presses, manual drills and CNC machine tools. See page 114 for operating guidelines.



Crosshole deburring an aluminum manifold.

BURR-RX® TUBE BRUSHES - Crimped Black Ceramic Filament - 1/4" Cadmium Plated Stems

Nominal Diameter	Traditional Diameter	Metric Diameter	Filament Dia./Grit	Length of Brush Part	Stem Diameter	Overall Length	Standard Pack	Item Number
3/8"	0.375"	9.53 mm	.026/120	1"	1/4"	3-1/2"	10	21758
1/2"	0.500"	12.70 mm	.026/120	1"	1/4"	3-1/2"	10	21759
5/8"	0.625"	15.88 mm	.026/120	1"	1/4"	3-1/2"	10	21761 •
3/4"	0.750"	19.05 mm	.026/120	1"	1/4"	3-1/2"	10	21762
7/8"	0.875"	22.23 mm	.026/120	1"	1/4"	3-1/2"	10	21763
1"	1.000"	25.40 mm	.026/120	1"	1/4"	3-1/2"	10	21764
1-1/4"	1.250"	31.75 mm	.026/120	1"	1/4"	3-1/2"	10	21765 •



TUBE BRUSHES - Crimped Round Silicon Carbide Filament - Double Stem, Single Spiral

Diameter	Filament Dia./Grit	Length of Brush Part	Stem Diameter	Overall Length	Standard Pack	Item Number
1/4"	.022/320	2"	5/32"	5"	10	21126
3/8"	.022/320	2"	5/32"	5"	10	21128
1/2"	.022/320	2"	3/16"	5"	10	21130 •
5/8"	.022/320	2"	7/32"	5"	10	21325
	.040/80					21132
11/16"	.022/320	2"	7/32"	5"	10	21133
	.040/80					21134
3/4"	.022/320	2-1/2"	1/4"	5-1/2"	10	21327
	.040/80					21136
7/8"	.022/320	2-1/2"	1/4"	5-1/2"	10	21136
	.040/80					21976
1"	.022/320	2-1/2"	1/4"	5-1/2"	10	21138
	.040/80					21328
1-1/4"	.022/320	2-1/2"	1/4"	5-1/2"	10	21306
	.022/120					21304
1-1/2"	.022/320	2-1/2"	1/4"	5-1/2"	10	21305
	.035/180					21309
2"	.022/320	2-1/2"	1/4"	5-1/2"	10	21308
	.040/80					21330
	.040/80					21473



TUBE BRUSHES - Micro Abrasive - For ultra-fine deburring and finishing of small internal holes.

Diameter	Length of Brush Part	Stem Diameter	For Hole Diameters		Overall Length	Standard Pack	Item Number
			Decimal	Fraction			
2000 Grit Aluminum Oxide Filament							
.030"	1/2"	.015	.031"	1/32"	4"	10	26900
.050"	1/2"	.022	.047"	3/64"	4"		26901
.075"	3/4"	.033	.063"	1/16"	4"		26902
.090"	3/4"	.041	.078"	5/64"	4"		26903
.105"	1"	.041	.094"	3/32"	4"		26904
.125"	1"	.064	.109"	7/64"	4"		26905
.135"	1"	.075	.125"	1/8"	4"		26906
600 Grit Aluminum Oxide Filament							
.165"	1"	.087	.156"	5/32"	5"	10	26907
.190"	1"	.087	.188"	3/16"	5"		26908
.260"	1"	.115	.250"	1/4"	5"		26909
.325"	1"	.115	.313"	5/16"	5"		26910
.385"	1"	.147	.375"	3/8"	5"		26911
.515"	1"	.194	.500"	1/2"	5"		26912
.640"	1"	.194	.625"	5/8"	5"		26913 •
.765"	1"	.212	.750"	3/4"	5"		26914 •



• Non-stock product, contact Customer Service for lead times and minimum order quantities.

COATED ABRASIVES
 NON-WOVEN ABRASIVES
 POWER BRUSHES
 NYLOX BRUSHES
 PACKAGED ITEMS
 MAINTENANCE

FLAT SURFACE DEBURRING PRODUCTS

DISC BRUSHES

Manufactured using a tufted filament configuration and longer trim length for increased aggression, greater conformability and longer product life in comparison to monofilament disc brushes, which feature a distribution of short individual bristles.

Burr-Rx® disc brushes feature Weiler's advanced black ceramic grain filament, which delivers up to a 400% greater edge cutting action in comparison to traditional silicon carbide and aluminum oxide filaments for the fastest, most aggressive deburring action for minimum cycle times and maximum life.

All Burr-Rx disc brushes are manufactured using a new process that results in a very consistent, flat brush face in comparison to traditional construction, which utilizes a molded backing. The high dimensional precision of these tools means that the brushes are suitable for the most critical applications and perform more consistently from first part to last. In addition, the machined polymer backings are designed to mount directly onto a standard shell mill holder for convenient use in CNC machining centers.

APPLICATIONS

- Deburring flat surfaces on machined components
- Deburring face-milled castings or forgings
- Improving texture characteristics on machined or ground surfaces
- Blending tool marks after machining or grinding



Deburring a bearing cage in a CNC machining center.



Disc brush shown with shell mill holder

DISC BRUSHES

0.075" - 0.100" DEPTH OF INTERFERENCE



OPERATING SPEEDS - DISC BRUSHES

Diameter	RPM
1-3/4" & 2"	1,750 - 2,000
3"-4"	1,500 - 1,750
5" - 6"	1,250 - 1,500
8"	800 - 1,000
10"	700 - 800
12"	600 - 700
14"	500 - 600

FEED RATE RECOMMENDATIONS

Feed rate is determined by the amount of deburring, edge radiusing or surface finishing required, and the type of material that is being processed. It is generally application specific. Slower feeds result in a more aggressive brushing action. Based on the brushing action desired for a specific application, the feed rate can be increased or decreased.

Material	SiC and AO Grain Feed Rate	Burr-Rx Grain Feed Rate
Non-Ferrous	50 in./min.	80 in./min.
Cast Iron	30 in./min.	60 in./min.
Mild Steel and Ductile Iron	25 in./min.	50 in./min.
Stainless and Alloy Steels	15 in./min.	30 in./min.
Titanium and High Nickel Alloys	10 in./min.	30 in./min.



86112

BURR-RX® SHELL MILL HOLDER DISC BRUSHES - Crimped Black Ceramic Filament

Compatible with 3" shell mill holders.

Diameter	Filament Dia./Grit	Arbor Hole	Trim Length	Max. RPM	Standard Pack	Item Number					
Round Filament											
4"	.026/120	1-1/4"	1-1/2"	2,500	1	86112					
	.043/120					86113					
	.055/80					86114*					
6"	.026/120	1-1/4"	1-1/2"	2,500	1	86115					
	.043/120					86116					
	.055/80					86117*					
8"	.043/120	1-1/4"	1-1/2"	2,000	1	86142 •					
	.055/80					86143* •					
	.043/120					86121					
10"	.055/80	1-1/4"	1-1/2"	2,000	1	86122*					
	Rectangular Filament										
	4"					80	1-1/4"	1-1/2"	2,500	1	86167*
6"	80	1-1/4"	1-1/2"	2,500	1	86198*					
8"	80	1-1/4"	1-1/2"	2,500	1	86199* •					

* Maximum Density

• Non-stock product, contact Customer Service for lead times and minimum order quantities.



86143

COMPOSITE HUB DISC BRUSHES - Silicon Carbide Filament

Diameter	Filament Dia./Grit	Arbor Hole	Drive Arbor Recommendation	Trim Length	Max. RPM	Standard Pack	Item Number
Crimped Round Filament							
3"	.035/180	7/8"	07700	1-1/2"	2,500	1	85776
	.040/120						85778
3-1/2"	.022/320	7/8"	07700	1-1/2"	2,500	1	85792
	.035/180						85794
	.040/80						85798 •
4"	.035/180	7/8"	07700	1-1/2"	2,500	1	85814
	.040/120						85816
	.040/80						85818 •
5"	.035/180	7/8"	07700	1-1/2"	2,500	1	85832
6"	.035/180	7/8"	07701	1-1/2"	2,000	1	85850
	.040/120						85852
	.040/80						85854
8"	.035/180	7/8"	07702	1-1/2"	2,000	1	85908 •
12"	.040/120	7/8"	07703	1-1/2"	1,750	1	85948 •
Rectangular Filament							
3"	120	7/8"	07700	1-1/2"	2,500	1	85786
	80						85788
3-1/2"	80	7/8"	07700	1-1/2"	2,500	1	85806
4"	120	7/8"	07700	1-1/2"	2,500	1	85824 •
	80						85826
	80						85995 •
5"	120	7/8"	07700	1-1/2"	2,500	1	85842 •
	80						85844
	80						85978 ••
6"	120	7/8"	07701	1-1/2"	2,000	1	85860 •
	80		07701				85862
	80		07715				85996 •
	80		07715				85901* ••
8"	120	7/8"	07702	1-1/2"	2,000	1	85920 •
	80						85922 •
9"	80	7/8"	07702	1-1/2"	1,750	1	85997 ••
10"	80	7/8"	07703	1-1/2"	1,750	1	85940 •

* Banded for extra aggression

• Maximum density



Deburring the edges of an aluminum engine cover.



85852



85978

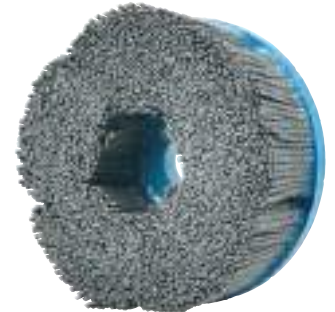

85786

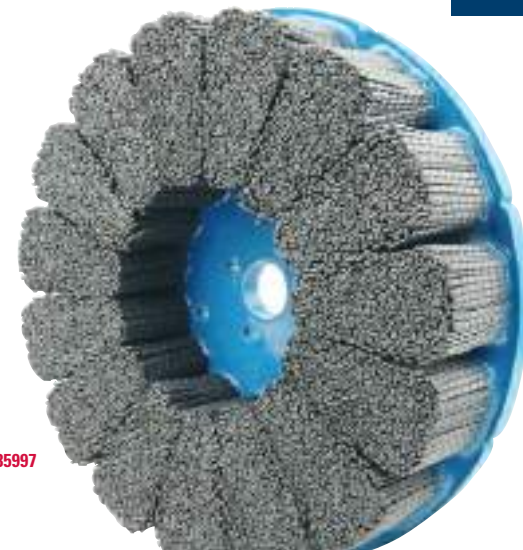

85997

COATED ABRASIVES

NON-WOVEN ABRASIVES

POWER BRUSHES

NYLON BRUSHES

Arbor & Drive Hole Specifications for Composite Hub Disc Brushes

Brush Diameter	Arbor Hole Diameter	Drive Holes
3"-5", 6" Max. Density	7/8"	(2) 1/4" dia. on a 1-1/4" dia. bolt circle
6"	7/8"	(3) 1/4" dia. on a 3" dia. bolt circle
8"	7/8"	(4) 1/4" dia. on a 3" dia. bolt circle
10"	7/8"	(4) 1/4" dia. on a 1.625" dia. bolt circle
12"	7/8"	(4) 1/4" dia. on a 1.625" dia. bolt circle

NOTE

See adapters on page 133

• Non-stock product, contact Customer Service for lead times and minimum order quantities.



Removing burrs and breaking sharp edges on a transmission component.

MINI DISC BRUSHES

Featuring a precision machined aluminum cup, Weiler's mini-disc brushes are designed to be the most cost-effective media for applications requiring a smaller brushing tool.

APPLICATIONS

- Deburring flat surfaces on machined components
- Improving texture characteristics on machined or ground surfaces
- Deburring face-milled castings or forgings
- Blending tool marks after machining or grinding



85733



85752



85981

BURR-RX® MINI DISC BRUSHES - Maximum Density - Crimped Black Ceramic Filament

Diameter	Filament Dia./Grit	Arbor Hole	Drive Arbor + Recommendation	Trim Length	Max. RPM	Standard Pack	Item Number
Round Filament							
2"	.026/120	3/8"	89029 or 89033	1-1/4"	4,500	2	86106
	.035/80					1	85738
	.043/120					2	86107
	.055/80					2	85733
3"	.026/120	3/8"	89029 or 89033	1-1/4"	4,500	1	86109
	.035/80						86013
	.043/120						86110
	.055/80						86111
Rectangular Filament							
2"	80	3/8"	89029 or 89033	1-1/4"	4,500	1	85736
3"	80	3/8"	89029 or 89033	1-1/4"	4,500	1	86014

+ See page 133 for drive arbor specifications.

MINI DISC BRUSHES - Silicon Carbide Filament

Diameter	Filament Dia./Grit	Arbor Hole	Drive Arbor + Recommendation	Trim Length	Max. RPM	Standard Pack	Item Number
Round Filament							
1-3/4"	.035/180	5/8"	89023 • or 89024	1-1/4"	6,000	2	85753
	.040/80						85750
Rectangular Filament							
1-3/4"	80	5/8"	89023 • or 89024	1-1/4"	6,000	2	85752 •
2"	80	3/8"	89023 • or 89024	1-1/4"	4,500	2	85773*
3"	80	3/8"	89023 • or 89024	1-1/4"	4,500	1	85981*

+ See page 133 for drive arbor specifications. * Maximum density



"I have had no issues with any Weiler products. They are reliable. They make a good product. I don't think you could ask for anything else."

- Richard Carpenter, Nuclear Industry Worker

• Non-stock product, contact Customer Service for lead times and minimum order quantities.

END BRUSHES

Featuring an integral stem for convenient mounting into a tool holder or collet, Nylox® end brushes and miniature end brushes are suitable for addressing recesses and internal features, or delivering a targeted brushing action to a specific area on a part.

APPLICATIONS

- Deburring small recessed areas and internal part features
- Finishing slots and recessed surfaces on machined parts



Blending tool marks on a hydraulic component.

BURR-RX® END BRUSHES - Banded - Crimped Round Black Ceramic Filament - Mounted on 1/4" Stems

Diameter	Filament Dia./Grit	Trim Length*	Recommended RPM	Overall Length	Max. RPM	Standard Pack	Item Number
3/8"	.043/120	1/4"	4,500 - 5,000	2-3/8"	10,000	10	86099
1/2"	.026/120 .043/120	1/4"	4,500 - 5,000	2-7/16"	10,000	10	86100 86101
3/4"	.026/120 .043/120	1/4"	4,200 - 4,500	2-7/16"	10,000	10	86102 86103
1"	.026/120 .043/120 .055/80	1/4"	3,500 - 3,800	2-5/8"	10,000	10	86104 86105 86097

* Trim length from bands



86104

END BRUSHES - Banded - Crimped Round Silicon Carbide Filament - Mounted on 1/4" Stems

Diameter	Filament Dia./Grit	Trim Length*	Overall Length	Max. RPM	Standard Pack	Item Number
1/2"	.022/320 .035/180 .040/120	3/8"	2-9/16"	10,000	10	11160 11161 11162
3/4"	.035/180 .040/120	3/8"	2-7/16"	10,000	10	11165 11166 •
1"	.035/180 .040/120	3/8"	2-11/16"	10,000	10	11169 11170

* Trim length from bands



11166

END BRUSHES - Crimped Round Silicon Carbide Filament - Mounted on 1/4" Stems

Diameter	Filament Dia./Grit	Trim Length	Overall Length	Max. RPM	Standard Pack	Item Number
3/4"	.022/320 .035/180 .040/120	7/8"	1-1/2"	10,000	10	10152 10153 10154
1"	.022/320 .035/180 .040/120	7/8"	2-3/4"	10,000	10	10155 10156 10157



10154

MINIATURE END BRUSHES - Plastic Ferrule - Crimped Round Silicon Carbide Filament

Mounted on 1/8" stems

Diameter	Filament Dia./Grit	Trim Length	Overall Length	Max. RPM	Standard Pack	Item Number
3/16"	.018/500	1/4"	1-7/8"	37,000	144	26136
1/4"	.018/500	3/8"	2-1/8"	37,000	144	26138
5/16"	.018/500	9/16"	2-11/32"	25,000	144	26146



26136

COATED ABRASIVES

NON-WOVEN ABRASIVES

POWER BRUSHES

NYLOX BRUSHES

PACKAGED ITEMS

MAINTENANCE

• Non-stock product, contact Customer Service for lead times.

TARGETED FEATURE DEBURRING PRODUCTS

WHEEL BRUSHES



Deburring a vane section for a jet engine.

Weiler's Nylox® abrasive nylon wheel brushes featuring composite metal hub and composite hub construction are manufactured using a molded polymer material to retain the filaments. In comparison to traditional metal hub construction that folds the fill material around an internal retaining ring or wrap wire, these techniques result in a significant increase in fill density and elimination of filament breakage, offering the lowest cost-of-use and greatest consistency of performance in production applications.

Weiler's composite metal hub wheels marry the high density and superior filament retention of composite wheels with the dimensional stability and shock resistance of metal hub construction, and they feature 2" arbor holes, which allows for convenient mounting on many pieces of equipment.

Burr-Rx® wheels feature Weiler's advanced black ceramic grain filament, which delivers up to a 400% greater edge cutting action in comparison to traditional silicon carbide and aluminum oxide filaments for the fastest, most aggressive deburring action to minimize cycle times and maximize media life.

APPLICATIONS

- Precision deburring of component parts after machining or grinding
- Improving texture characteristics on machined or ground surfaces
- Honing cutting tools and generating specific edge profiles and radii
- Light duty cleaning and finishing of metals; light sanding of woods and composites

BURR-RX® CRIMPED FILAMENT WHEELS

Composite Metal Hub* - Crimped Round Black Ceramic Filament

Diameter	Filament Dia./Grit	Arbor Hole	Face Width	Trim Length	Thickness At Face Plates	Max. RPM	Standard Pack	Item Number
6"	.026/120	2"	3/4"	1"	15/16"	4,000	1	86123
	.035/80							86181
	.043/120							86124
	.055/80							86120
8"	.026/120	2"	7/8"	2"	15/16"	4,000	1	86126
	.043/120							86127
	.055/80							86128
10"	.026/120	2"★	1-1/8"	2"	7/8"	1,800	2	86129
	.035/80							86182 •
	.043/120							86130
	.055/80							86131
12"	.026/120	2"★	1-1/4"	3"	7/8"	1,800	2	86132
	.043/120							86133
	.055/80							86134
14"	.026/120	2"★	1"	1-3/4"	3/4"	1,800	2	86135
	.035/80							86108
	.043/120							86136
	.055/80							86137
14"	.043/120	2"★	1-1/4"	4"	7/8"	1,800	2	86139
	.055/80							86140

*Patent Pending

★ 1/2" x 1/4" Double Keyway

• Non-stock product, contact Customer Service for lead times and minimum order quantities.

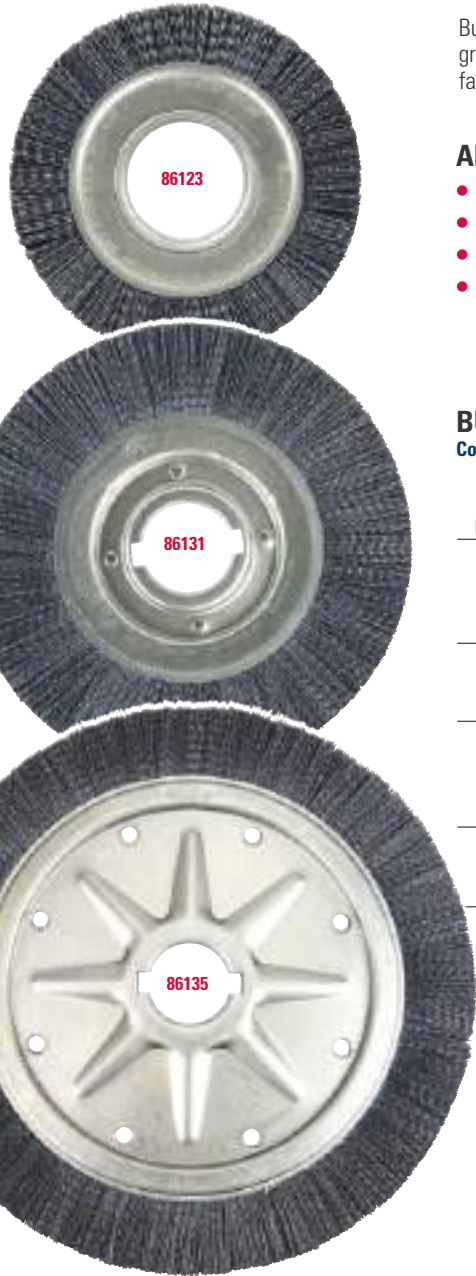

BURR-RX CRIMPED FILAMENT WHEELS

Composite Hub - Crimped Round Black Ceramic Filament

O.D. x I.D.	Filament Dia./Grit	Face Width	Trim Length	Thickness At Face Plates	Max. RPM	Standard Pack	Item Number
14" x 7-1/4"	.043/120	1"	2-3/4"	15/16"	1,800	2	84941 •
	.055/80						83405 •

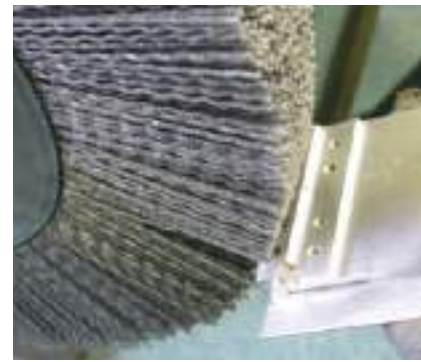

Removing burrs from an aluminum heat sink.

CRIMPED FILAMENT WHEELS - Composite Metal Hub* - Crimped Round Silicon Carbide Filament

Diameter	Filament Dia./Grit	Arbor Hole	Face Width	Trim Length	Thickness Through Arbor	Max. RPM	Standard Pack	Item Number
6"	.018/500	2"	1"	1-1/4"	1-1/16"	4,000	1	83000
	.022/320							83010
	.022/120							83011 •
	.035/180							83030
	.040/120							83040
	.040/80							83050 •
8"	.018/500	2"	1"	2-1/4"	3/4"	4,000	2	83100
	.022/320							83110
	.022/120							83111
	.035/180							83130
	.040/120							83140 •
	.040/80							83150
10"	.022/320	2"★	1-1/8"	2"	7/8"	1,800	2	83513 •
	.035/180							83514 •
	.040/80							83516
12"	.040/120	2"★	1-1/4"	3"	7/8"	1,800	2	83717
	.040/80							83718

*Patent Pending

★ 1/2" x 1/4" Double Keyway



METAL HUB BASIC SECTIONS

CRIMPED FILAMENT BASIC SECTIONS - Metal Hub - Crimped Round Silicon Carbide Filament

For light-duty deburring and finishing in applications such as low-volume manual deburring or general use in a tool room or shop.

O.D. x I.D.	Filament Dia./Grit	Face Width	Trim Length	Thickness Through Arbor	Max. RPM	Standard Pack	Item Number
6" x 2"	.022/320	5/8"	1-1/2"	9/16"	6,000	2	20600
	.035/180						20610
	.040/120						20620
8" x 2"	.022/320	5/8"	2-1/2"	9/16"	5,000	2	20630 •
	.040/120						20650



NOTE

See adapters on page 133

• Non-stock product, contact Customer Service for lead times and minimum order quantities.



NARROW FACE WHEELS

BURR-RX® HEAVY-DUTY NARROW FACE WHEELS - Metal Hub - Crimped Round Black Ceramic Filament

Diameter	Filament Dia./Grit	Arbor Hole	Face Width	Trim Length	Thickness Through Arbor	Max. RPM	Standard Pack	Item Number
3"	.026/120	5/8"-1/2"	9/16"	1/2"	7/16"	6,000	2	31240
	.035/80							31241
4"	.026/120	5/8"-1/2"	5/8"	1"	7/16"	6,000	2	31110
	.035/80							31270
	.043/120							31280 •
	.055/80							31290 •

Deburring the tip of a turbine blade.



31110



86165

BURR-RX NARROW FACE WHEELS - Metal Hub - Crimped Round Black Ceramic Filament

Diameter	Filament Dia./Grit	Arbor Hole	Face Width	Trim Length	Thickness Through Arbor	Max. RPM	Standard Pack	Item Number
3"	.035/80	1/2"-3/8"	3/8"	1/2"	7/16"	6,000	2	31102
4"	.026/120	1/2"-3/8"	1/2"	7/8"	7/16"	6,000	2	86165 •
	.035/80							31103
	.043/120							31100
	.055/80							31105
6"	.026/120	5/8"-1/2"	5/8"	7/8"	11/16"	4,500	2	31134
	.043/120							31135
	.035/80							31136

HEAVY-DUTY NARROW FACE WHEELS - Metal Hub - Crimped Round Silicon Carbide Filament

Diameter	Filament Dia./Grit	Arbor Hole	Face Width	Trim Length	Thickness Through Arbor	Max. RPM	Standard Pack	Item Number
4"	.022/320	5/8"-1/2"	5/8"	1"	7/16"	6,000	2	31255 •
	.035/180							31265
	.040/120							31275 •
	.040/80							31285 •



31285

NARROW FACE WHEELS - Metal Hub - Crimped Round Silicon Carbide Filament

Diameter	Filament Dia./Grit	Arbor Hole	Face Width	Trim Length	Thickness Through Arbor	Max. RPM	Standard Pack	Item Number
3"	.035/180	1/2"-3/8"	3/8"	1/2"	7/16"	6,000	2	31084
	.040/120							31094
4"	.022/320	1/2"-3/8"	1/2"	7/8"	7/16"	6,000	2	31104
	.035/180							31114
	.040/120							31124
6"	.022/320	5/8"-1/2"	5/8"	7/8"	11/16"	4,500	1	31121
	.035/180							31122
	.040/120							31123



31124

• Non-stock product, contact Customer Service for lead times and minimum order quantities.

APPLICATION ENGINEERED WHEELS



Deburring a camshaft with a Nylox wheel.

CRIMPED FILAMENT WHEELS - Composite Hub - Crimped Round Silicon Carbide Filament

O.D. x I.D.	Filament Dia./Grit	Face Width	Trim Length	Thickness Through Arbor	Max. RPM	Standard Pack	Item Number
8" x 2"*	.040/120	7/8"	2-1/8"	13/16"	3,600	2	83190 •
	.040/80						83180 •
10" x 2"	.018/500	1"	3"	1-1/16"	3,600	2	83300 •
	.035/180						83330
	.040/120						83340
	.040/80						83350
10" x 3-1/4"	.035/180	1"	2-5/16"	13/16"	1,800	2	83430 •
	.040/120						83440 •
	.040/80						83450
12" x 4-1/4"	.035/180	1"	3-1/8"	15/16"	1,800	2	84730 •
12" x 5-1/4"	.040/80	1-1/8"	2-3/4"	15/16"	1,800	2	83750
14" x 5-1/4"	.022/320	1-1/8"	3-3/4"	15/16"	1,800	2	83910
	.040/120						83940 •
	.040/80						83950
14" x 5-1/4"-2"*	.022/320	1-1/8"	3-3/4"	1-1/16"	1,800	2	85150 ••

• Same density as our standard 5-1/4" I.D. brushes, but requires no adapters for mounting on a 2" diameter shaft.

* 1/2" x 1/4" Double Keyway



DIAMOND FILAMENT WHEEL BRUSHES

Weiler's diamond filament wheels are ideal for producing edge radii on hard materials such as diamond, CBN, ceramic and glass. Our wheel brushes are made-to-order in a wide range of diameters and thicknesses. Additional configurations are available such as; tube brushes, composite hub disc brushes and end brushes. Other sizes and pricing are available on request. Please contact Customer Service at 800-835-9999.

DIAMOND FILAMENT WHEELS - Composite Hub - Round Diamond Filament

O.D. x I.D.	Filament Dia./Grit	Face Width	Trim Length	Thickness Through Arbor	Max. RPM	Standard Pack	Item Number
6" x 2"	.014/600	5/16"	1-1/4"	1/4"	3,600	1	83003 •
	.012/1000						83004 •



NOTE

See adapters on page 133

• Non-stock product, contact Customer Service for lead times and minimum order quantities.

FME AREA PRODUCT SOLUTIONS



Removing gasket material from a pipe flange.

In nuclear power plants, Foreign Material Exclusion (FME) programs may limit or even exclude the use of wire brushes in some areas during the performance of routine maintenance, repair or shut-down activities. Weiler has developed a FME-compliant tooling system to address the needs of plant operators and maintenance contractors working in these facilities as well as other industries where the potential introduction of broken wire filaments may be of concern. Weiler's FME Solutions program is a complete system consisting of non-wire brushing tools designed to perform a broad range of surface cleaning and preparation applications.

BLACK NYLOX® CERAMIC BRUSHES - The engineered ceramic grain in Weiler's Black Nylox filament is up to 400% more aggressive than the silicon carbide and aluminum oxide grain in other abrasive filaments, making it much more effective in surface cleaning applications. The efficient cutting action of the Black Nylox filament also generates less heat and makes it much more resistant to "smearing" than traditional nylon abrasive filaments.



31112

NARROW FACE WHEELS - Crimped Ceramic Filament
Used on edge for weld prep and cold weld cleaning.



Diameter	Filament Dia./Grit	Face Width	Arbor Hole	Max. RPM	Standard Pack	Item Number
4"	.055/80	1/2"	5/8"-11 Nut	4,800	5	31112 •

CONTROLLED FLARE END BRUSH - Crimped Ceramic Filament - 1/4" Stem
For cleaning corners and tight areas.



86159

Diameter	Filament Dia./Grit	Trim Length	Overall Length	Max. RPM	Standard Pack	Item Number
1"	.035/80	1-1/8"	2-1/2"	4,800	10	86159 •



95016

HAND SCRATCH BRUSHES - Crimped Ceramic Filament - For general purpose, light-duty cleaning.

Overall Length	Block Type	Brush Part	Grit Size	Trim Length	Standard Pack	Item Number
8-3/4"	Wood	2 x 9 Rows	120	5/8"	36	95016 •

NOTE

Nylon abrasive filament brushes require a lower operating RPM than most other power tool accessories and they cannot be used effectively on standard grinders.

• Non-stock product, contact Customer Service for lead times and minimum order quantities.

ADAPTERS AND DRIVE ARBORS

NOTE

The adapters and drive arbors listed on this page are for use with small diameter wheel brushes only; do not attempt to use them with cutting or grinding wheels, buffing wheels, or any type of abrasive wheel or disc.

METAL ADAPTERS - Reusable - Used in pairs and priced per pair.

Diameter	Arbor Hole Size	Used With	Standard Pack	Item Number
2"	1/2"	All 2" I.D. Wheels	1	03809
	5/8"			03810
	3/4"			03811
	7/8"			03824
	1"			03812
	1-1/4"			03813
	1-1/2"			03814
3-1/4"	3/4"	3-1/4" I.D. Wheels (When mounting only one wheel)	1	03910 •
	1-1/4"			03913 •
	2"			03915 •



03809



03944

STEEL FLANGES - Reusable - Used on the ends of a gang mount. Used in pairs and priced per pair.

Must be used in conjunction with Pressboard Adapters in chart below.

Flange O.D.	Arbor Hole Size	Used With	Standard Pack	Item Number
6-1/2"	1-1/4"	5-1/4" I.D.	1	03944 •

PRESSBOARD ADAPTERS - Used for centering 10", 12" and 14" Nylox® Wheels when gang mounting.

Must be used in conjunction with Steel Flanges in chart above.

Brush I.D.	Arbor Hole Size	Standard Pack	Item Number
5-1/4"	1-1/4"	1	03403 •



03403

PLASTIC ADAPTERS

Fixed Arbor Hole Size	Adapted Arbor Hole Size	Used With	Standard Pack	Item Number
1/2"	1/4"	Small Dia. Wheels	10	04400
1/2"	3/8"	Small Dia. Wheels	10	04401
5/8"	1/2"	Small Dia. Wheels	10	04402



04401

04402

MINIATURE & BURR-RX® DISC BRUSH DRIVE ARBORS - Includes drive arbor, set screw and hex key.

For Brush Diameter	Stem Diameter	Stem Length	Max. RPM	Standard Pack	Item Number
1-3/4"	1/4"	1-3/4"	6,000	1	89023* •
1-3/4"	3/8"	1-3/4"	6,000	1	89024*
2"-3"	1/2"	1-3/4"	6,000	1	89029*



89023

* For use with Burr-Rx Mini Disc brushes only. Products supplied with set screw and wrench.

MINIATURE & BURR-RX DISC BRUSH DRIVE ARBORS - Includes drive arbor, set screw and hex key. Recommended for operations in which brush rotation alternates between forward and reverse.

For Brush Diameter	Stem Diameter	Stem Length	Max. RPM	Standard Pack	Item Number
2"-3"	1/2"	1-3/4"	6,000	1	89033*



89033

* For use with Burr-Rx Mini Disc brushes only. Products supplied with set screw and wrench.

DISC BRUSH FLOW-THROUGH DRIVE ARBORS

Mounts Weiler disc brushes to any type of milling machine or CNC machine.

Fits	Arbor Hole	Drive Studs	Bolt Circle	Plate O.D.	Shaft Dia.	Stem Length	Std. Pack	Item Number
3", 4" and 5" Disc Brushes	7/8"	2	1-1/4"	2-7/8"	3/4"	2-3/4"	1	07700
6" Std. Tuft Disc Brushes NOT Max. Density	7/8"	3	3"	5-7/8"	3/4"	2-1/2"	1	07701
6" Max. Density Disc Brushes, also 5" Std. Tuft	7/8"	2	1-1/4"	4-7/8"	3/4"	2-1/2"	1	07715
8" and 9" Disc Brushes	7/8"	4	3"	7-7/8"	3/4"	2-1/2"	1	07702 •

Replacement kit includes: (1) 1/2"-13 locking flow-through bolt & (1) Belleville spring washer



07700

NOTE

- Do not adapt a wheel brush for use on a shaft diameter less than that specified by ANSI B165.1 or exceed the maximum wheel diameter specified for a drive arbor.
- Never mount a drive arbor onto a tool that operates above the maximum RPM rating of either the arbor or the brush (whichever may be lower) and be sure that the stem of the arbor is properly secured in the collet or chuck before use.



07718

• Non-stock product, contact Customer Service for lead times and minimum order quantities.

WHY WEILER

BONDED ABRASIVES

COATED ABRASIVES

NON-WOVEN ABRASIVES

POWER BRUSHES

NYLOX BRUSHES

PACKAGED ITEMS

MAINTENANCE

MAINTENANCE

WE HAVE YOU COVERED

The facility doesn't run itself. In fact, keeping things going is more than a full-time job. So you depend on your supplies to be ready at a moment's notice – if not before.

We know that when certain products are out of stock, certain activities come to a stop. You aren't going to let that happen on your watch – and neither are we.

No matter where you need them. No matter what they are. If they're Weiler products, they're only a click or a phone call away.

Technical Information	135-136, 153
Brooms, Sweeps & Handles	137-140
Upright & Whisk Brooms	141
Dusters, Dust Pans & Squeegees	142
Vehicle Care Products	143
Scrub & Utility Brushes	144-145
Mops & Dusting Brushes	146
Masonry & Applicator Brushes	147
Scratch Brushes	148-150
Flue Brushes	151
Tube Fitting Brushes	152
Paint & Parts Cleaning Brushes	154
Chip & Oil Brushes & Industrial Paint Brushes	155
Marking, Glue & Acid Brushes	156
Paint Rollers & Accessories	157



Display Packaged and Vending Ready Products Brochure

display pack and vending pack items are indicated throughout this catalog. See our brochure for the full line.

SELECTING THE RIGHT BRUSH





P PERFORMANCE LINE (INDUSTRIAL GRADE)

Engineered and manufactured to maximize performance and minimize operating costs in the most demanding surface conditioning applications. The use of superior construction, the highest quality materials and the most stringent manufacturing processes deliver the lowest cost-of-use and most consistent performance in heavy production environments.

V VALUE LINE (PROFESSIONAL GRADE)

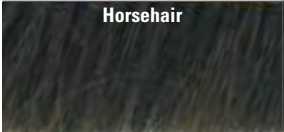
Weiler's value line is manufactured using similar product construction and the same exacting standards as other Weiler maintenance products, but engineered to provide cost-effective use specifically designed for the professional, providing a cost-effective price. Vortec Pro® maintenance products are an economical choice for the construction trades, low volume production shops and light-duty industrial MRO use.

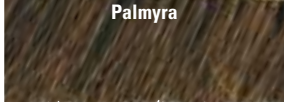
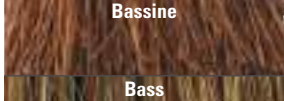
FILL MATERIALS GUIDE

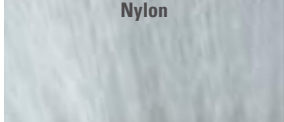
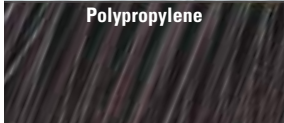
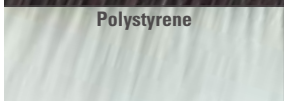
	Type	Advantages	Applications	Notes
ANIMAL	 Horsehair	<ul style="list-style-type: none"> • Very durable and resilient • Naturally flagged tips • Resistant to high temperatures (to 370°F) • Can be blended with other materials • Fine texture 	<ul style="list-style-type: none"> • Fine particles • Ideal for polished and smooth surfaces • Scratch-free sweeping 	<ul style="list-style-type: none"> • Not for use on oily or wet surfaces
NATURAL	 Tampico	<ul style="list-style-type: none"> • Material holds water very well • Heat, alkali and acid resistant (to 283°F) • Soft to medium texture • Good durability 	<ul style="list-style-type: none"> • Polishing, buffing and cleaning • Scrubbing and washing • Ideal for wet and dry applications 	<ul style="list-style-type: none"> • Natural color is off white • Can be dyed or bleached
	 Palmyra	<ul style="list-style-type: none"> • Softer and finer texture than Bassine • More economical than Bassine • Medium to coarse texture • Good durability 	<ul style="list-style-type: none"> • Used in garage, scrub, deck and patio brushes • Ideal for wet and dry applications 	<ul style="list-style-type: none"> • Brown in color
	 Bassine	<ul style="list-style-type: none"> • Coarse, tough fibers • Excellent durability 	<ul style="list-style-type: none"> • Heavy scrubbing and cleaning • Tasks requiring a tough, long-lasting natural fiber 	<ul style="list-style-type: none"> • Dark brown in color
	 Bass	<ul style="list-style-type: none"> • Good flexibility • Very coarse, tough fibers • Excellent durability 	<ul style="list-style-type: none"> • Heavy-duty cleaning applications • Use on rough surfaces 	<ul style="list-style-type: none"> • Dark brown in color
SYNTHETIC	 Nylon	<ul style="list-style-type: none"> • Excellent durability • Resistant to most acids & alkali • High water absorbency • Resistant to high temperatures (to 350°F) • Best man-made fiber to resist fatigue 	<ul style="list-style-type: none"> • Heavy-duty industrial • Scrubbing and cleaning • Wet and dry applications 	<ul style="list-style-type: none"> • May be level or crimped
	 Polypropylene	<ul style="list-style-type: none"> • Very durable • Acid, oil, bacteria and fungus resistant • Versatile • Resistant to high temperatures (to 225°F) • Will not absorb moisture 	<ul style="list-style-type: none"> • Variety of medium to coarse industrial applications 	<ul style="list-style-type: none"> • May be level or crimped
	 Polystyrene	<ul style="list-style-type: none"> • Extremely durable • Liquid and oil resistant • Resistant to temperatures (to 180°F) • Ends can be flagged 	<ul style="list-style-type: none"> • Used in vehicle care brushes • Used in fruit and vegetable wash brushes • Wet and dry applications 	<ul style="list-style-type: none"> • May be level or crimped • Not for use with sweeping compounds

FLOOR BRUSH SELECTION GUIDE

Surface Type	Debris	Recommended Brush
Tile, linoleum, highly polished	Fine dust	Black horsehair
Smooth wood	Fine to medium dirt	Flagged silver polystyrene
Smooth concrete	Fine to medium dirt	Black polypropylene
Uneven or rough floors, heavy traffic areas	Medium to heavy dirt and debris	Black tampico
Rough concrete, asphalt	Heavy, caked dirt, grease, litter	Black tampico - inner row of steel wire or palmyra

FLOOR BRUSH FEATURES

Block: Fill material is set into this part of the sweep.

Synthetic Foam Block:

- Made with a synthetic cellular core surrounded by a solid skin.
- Will not crack, split, warp or house contaminating bacteria.
- Water, solvent and mild acid resistant.
- Lighter weight than hardwood blocks.

Dense Fill:

- Set into the block and serves as the actual working part of the brush.
- More efficient sweeping.
- Longer brush life.

Flagged Tips:

- Each synthetic filament end is mechanically split, forming multiple tips which "pick up" fine dust and dirt particles.
- Horsehair has naturally tapered or flagged tips.

Reorder Number:

- Shown on block.

Lacquered Hardwood Block:

- Made of natural, kiln-dried hardwood.
- Resists moisture.
- Helps prevent cracking, increasing brush life.

Two Handle Holes:

- Allows user to change sweeping direction to prevent the fill material from setting in one direction. Periodically changing sweeping direction increases the life of the brush.

Staggered Hole Pattern:

- Prevents gaps in the fill material so brush sweeps up all the dirt in its path.



Center / Border Fill



Border (Casing)
Moves fine dust and dirt

Center
Loosens and moves heavy dirt

Solid Brush Face with Flared Ends:

- The tufts of fill material on each end of a contractor, floor, garage or street brush are flared outward.
- Flared ends allow the brushing material to get into corners without marking or scraping the wall with the block.
- Prevents a gap in the middle of the brush.

FLOOR BRUSH CARE

Storage - Floor brushes should be hung when not in use so no weight is against the fill material. This will help keep the shape and prolong the life of the brush.

Handles - The handle should be periodically re-positioned from one staff hole to the other to prevent fill material from setting in one position. The use of a brace will help prevent handle breakage. Perma-Flex™ (#44301) handles are guaranteed to outlast the life of the brush.

Blocks - Avoid knocking a wood block against the floor to remove

embedded material, as this will damage the end of the block.

Cleaning - Synthetic filled brushes can be cleaned with detergent and water. Fiber filled brushes should be combed to remove dirt and other foreign material. Dip coarse natural fiber brushes in water to help prevent breakage due to dry fiber.

FLOOR BRUSHES

PRO-FLEX™ SWEEPS - QUICK ASSEMBLY & UNBREAKABLE!

Easy-to-Assemble: The convenient and easy-to-assemble T-knob construction of the Pro-Flex Sweep takes less than 1 minute to assemble. The handle connects easily and securely to the broom head, and there's no need for a brace!

Unbreakable: Utilizing an advanced polymer technology, the Pro-Flex Sweep's unique handle/sweep connector flexes on impact, providing unbelievable shock absorbency... and it's unbreakable! Ideal for the most demanding applications on a construction site.

More Maneuverable: Without the need for a brace, the Pro-Flex Sweep is lighter, easy to maneuver and eliminates potential damage to low surface areas.

The Pro-Flex Sweep... the strongest sweep on the market AND the easiest to assemble!

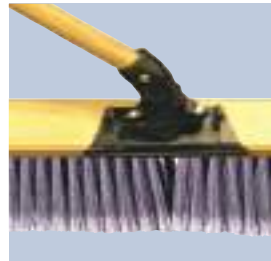

Flexible connection makes these sweeps the strongest on the market!



The Pro-Flex Sweep's indestructible design will make it the last sweep you will ever buy!



P PRO-FLEX SWEEPS - Hardwood Block

Includes comfort grip Pro-Flex handle and scraper for removal of heavy, caked dirt and debris.

Block Size	Fill Material	Trim Length	Standard Pack	Item Number
Convenient scraper attaches handle to sweep head for display and shipping purposes				
24"	Flagged Grey Polystyrene Border with Stiff Black Polypropylene Center	3"	1	44600
24"	Palmyra	4"	1	44601
24"	Medium Maroon Polypropylene	3-1/4"	1	44604
24"	Stiff Blue Polypropylene	3-1/4"	1	44606

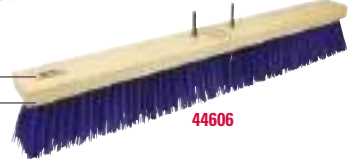

P CONTRACTOR BROOMS - Hardwood Block - Heavy-duty 12-gauge steel brace included with all brooms. Ideal for construction sites and other heavy use environments.

Block Size	Fill Material	Trim Length	Standard Pack	Item Number
Fine Sweeping - For fine dust and dirt on smooth surfaces				
24"	Flagged Silver Polystyrene	3"	1	44553
Medium Sweeping - For general purpose sweeping on semi-smooth surfaces				
24"	Flagged Grey Polystyrene Border	3"	1	44581
Coarse Sweeping - For heavy dirt and debris on very rough surfaces				
24"	Palmyra	4"	1	44584
24"	Medium Maroon Polypropylene	3-1/4"	1	44587
24"	Stiff Blue Polypropylene	3-1/4"	1	44590



NOTE

- For Contractor Brooms, use Handle No. 44635 (1-1/8" x 60").
- Handle not included in price - order handle separately.
- Bolt to assemble broom is included with the broom, not with the handle.

P PERMA-SWEEP™ - Synthetic Foam Block - Made of durable materials designed to resist acid and bacteria.

Block Size	Fill Material	Trim Length	Standard Pack	Item Number
Fine Sweeping - For fine dust and dirt on smooth surfaces				
18"	Flagged Green Polystyrene	3"	1	42163
24"				42164
Medium Sweeping - For general purpose sweeping on semi-smooth surfaces				
18"	Yellow Polypropylene	3"	1	42165
24"				42166
Coarse Sweeping - For heavy dirt and debris on very rough surfaces				
18"	Maroon Polypropylene	3"	1	42167
24"				42168



NOTE

- For Perma-Sweep Floor Brushes, use Perma-Flex Handle No. 44301 (15/16" x 60") Guaranteed for the life of the brush!
- Handle not included in price - order handle separately.

Key:

P Performance line
Industrial Grade

V Value line
Professional Grade

COATED ABRASIVES

NON-WOVEN ABRASIVES

POWER BRUSHES

NYLON BRUSHES

PACKAGED ITEMS

MAINTENANCE



Weiler offers a broad array of floor brushes in various sizes and fill materials for fine, medium and coarse sweeping applications. Choose from flagged tips that pick up fine dust and dirt to durable fibers that sweep heavy-caked dirt and debris. The lacquered hardwood blocks resist moisture and help prevent cracking, thereby increasing brush life.

NOTE



- Handle No. 44300 (15/16" x 60") recommended for use with all Floor Brushes.
- Handle not included in price - order handle separately.

Sweeping saw dust on a smooth surface.

P FINE SWEEPS - Lacquered Hardwood Block

For dust and fine dirt on smooth surfaces: Tile, Wood, Linoleum, Marble, Ceramic Tile and Smooth Concrete.



Block Size	Fill Material	Trim Length	Standard Pack	Item Number
18"	Black Horsehair	3"	1	42001
24"				42002
18"	Black Horsehair and Black Polypropylene Blend	3"	1	42013
24"				42014
10"	Flagged Silver Polystyrene	3"	12	70312
18"				42041
24"				42042
36"				42098*

* Brace included

V VORTEC PRO® FINE SWEEPS - Lacquered Hardwood Block

Reliable and efficient sweeps at a value price.

Block Size	Fill Material	Trim Length	Standard Pack	Item Number
18"	Flagged Grey Polystyrene	3"	12	77013
24"				77014

P MEDIUM SWEEPS - Lacquered Hardwood Block

General purpose sweeping on semi-smooth surfaces: Wood, Smooth Concrete, Asphalt and Factory/Shop Floors.



Block Size	Fill Material	Trim Length	Standard Pack	Item Number
14"	Black Tampico	3"	1	42114
16"				42006
18"				42007
24"				42008
36"				42047*
18"	Horsehair Border with Black Tampico Center	3"	1	42016
24"				42017
36"				42049*
18"	Black Polypropylene	3"	1	42035
24"				42037
36"				42095*

* Brace included

V VORTEC PRO MEDIUM SWEEPS - Lacquered Hardwood Block

Reliable and efficient sweeps at a value price.



Block Size	Fill Material	Trim Length	Standard Pack	Item Number
18"	Dark Grey Polystyrene Border with Black Polypropylene Center	3"	1	25234
24"				25235
18"	Black Tampico	3"	1	25231
24"				25232

P COARSE SWEEPS - Lacquered Hardwood Block

For heavy dirt and debris on rough surfaces: Wood, Concrete, Asphalt and Brick.

Block Size	Fill Material	Trim Length	Standard Pack	Item Number
18"	Black Tampico with 1 row Tempered Steel Wire in Center	3"	1	42134
24"				42135

P GARAGE BRUSHES - Lacquered Hardwood Block

For wet or dry sweeping heavy, caked dirt and debris on rough surfaces: Concrete, Garage/Factory Floors, Rough Wood, Sidewalks, Barns and Brick Surfaces. Solvent, oil, chemical and liquid resistant.

Block Size	Fill Material	Trim Length	Standard Pack	Item Number
16"	Palmyra	4"	1	42021
18"				42022
24"				42023
36"				42138*
18"	Maroon Polypropylene	3-1/4"	1	42025
24"				42026
36"				42149*

* Brace included



Sweeping metal shavings from a shop floor.

V VORTEC PRO® GARAGE BRUSHES - Lacquered Hardwood Block

Reliable and efficient brushes at a value price.

Block Size	Fill Material	Trim Length	Standard Pack	Item Number
18"	Palmyra	4"	1	25241
24"				25242
18"	Maroon Polypropylene	3-1/4"	1	25238
24"				25239

NOTE



- Handle No. 44435 (1-1/8" x 60") recommended for use with all Garage Brushes.
- Handle not included in price - order handle separately.



42023

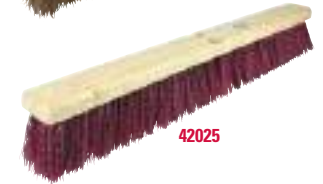

42025

COATED ABRASIVES

NON-WOVEN ABRASIVES

P STREET BROOMS - Hardwood Block - Wide flared ends for sweeping close to curbs and walls. For heavy-duty wet or dry sweeping: Streets, Sidewalks, Loading Docks, Parking Lots, Driveways and all Asphalt Surfaces.

Block Size	Fill Material	Trim Length	Standard Pack	Item Number
16"	Natural Palmyra	6-1/4"	6	70208
16"	Dyed Palmyra	6-1/4"	6	70209
16"	Bass & Palmyra Blend	6-1/4"	6	42032
16"		7-1/4"		42099
16"	Brown Polypropylene	5-1/4"	6	42033
18"				42173
24"				42174
16"	Orange Polypropylene	5-1/4"	6	70212
18"				42054
24"				42055
14"	White Polypropylene Fill Orange Block	4"	6	70210 •
16"				70211



70209



42032



42033

POWER BRUSHES

NYLON BRUSHES

P WIRE BROOMS - Hardwood Block

For sweeping or scrubbing concrete or stone floors, driveways, etc. Ideal for sweeping heavy chips and debris.

Block Size	Fill Material	Trim Length	Standard Pack	Item Number
14"	Flat Wire	5"	1	42030
16"	Round Wire	3-3/4"	6	70215

NOTE



- Street and wire brooms require a tapered tip handle.
- Handle No. 44020 (1-1/8" x 60") recommended for use with all Street & Wire Brooms.
- Handle not included in price - order handle separately.



42030

PACKAGED ITEMS

MAINTENANCE

HANDLES, BRACES & TIPS



The Perma-Flex tip is guaranteed not to break when used with a Perma-Sweep.



44018



44020



44300



44301



44635



42383



75555



44499



44561



44563



44021



44290



44317



75505

P

WOOD HANDLES - Quality hardwood

Length	Diameter	Tip	Description	Std. Pack	Item No.
48"	7/8"	Threaded	Use with floor and garage brushes.	12	75527
48"	15/16"	Wood			44571
60"	15/16"				44018
60"	1-1/8"				44019
72"	15/16"				44303
11"	3/4"	Tapered	Use with masonry and roof brushes, street brooms, floor and deck scrubs and squeegees.	36	75528 •
48"	7/8"	Wood			44574
54"	1-1/8"				44573
60"	1-1/8"				44020
72"	1-1/8"				44306
48"	15/16"	Threaded	Heavy-duty metal tip provides additional strength.	12	75525
60"	15/16"	Metal			44300
60"	1-1/8"				44435
72"	15/16"				44302
60"	15/16"	Perma-Flex™	Durable threaded plastic tip guaranteed not to break when used with Perma-Sweep™ Floor Brushes.	12	44301
60"	1-1/8"	-	Use with Contractor Brooms.	12	44635

• Non-stock product, contact Customer Service for lead times and minimum order quantities.

P

METAL HANDLES - Reinforced, heavy-duty metal handles are available in two colors and optional foam cover.

Length	Diameter	Tip	Description	Std. Pack	Item No.
48"	3/4"	Threaded Plastic	Black metal with plastic hang cap.	12	42383
60"	15/16"	Threaded Metal	Black plastic coat with plastic hang cap.	12	44577
60"	15/16"	Threaded Metal	Black plastic coat with black foam cover and plastic hang cap.	12	44578

V

VORTEC PRO® METAL HANDLES - Reliable and efficient handles at a value price.

Length	Diameter	Tip	Description	Std. Pack	Item No.
60"	15/16"	Threaded Plastic	Black plastic coat with convenient hang-up cap.	12	75555

P

METAL TELESCOPING HANDLES

Use telescoping handles to shorten or extend the reach of the handle.

Length	Diameter	Type	Use	Std. Pack	Item No.
6' extends to 12'	-	Telescoping	Window, wall and Vehicle wash brushes	6	44499

P

FIBERGLASS HANDLES - Fiberglass handles are stronger than wood or metal. Virtually indestructible.

Length	Diameter	Tip	Description	Std. Pack	Item No.
56-3/4"	1"	Tapered/Threaded	Hollow handle	12	44561*
54"	1"	Threaded	Honeycomb core	12	44562
60"	1"	Threaded	All white	12	44563+

* For use with both tapered and threaded holes + Approved for the food service industry

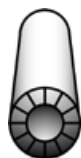

Fiberglass with polyethylene reinforced honeycomb core



Fiberglass hollow handle.

P

HANDLE ACCESSORIES

Description	Use	Std. Pack	Item No.
Steel brace. Fits all handle sizes.	Reinforces & locks handle to block. (Standard with sweeps 30" and larger)	12	44021
Heavy-duty steel brace attaches to block with wood screws and wraps around handle. Fits all handle sizes.	Increases life of the brush by providing extra support for handle and block.	12	44290
Replacement handle thread. Made of heavy-duty fiberglass. For any 15/16" diameter handle.	Cut off damaged threads and slip this tip in place for a new handle.	12	44317
Tapered Adapter to tapered ends.	Converts threaded handle ends	12	75505

UPRIGHT AND WHISK BROOMS

Made of fine quality broom corn, fiber or synthetic material, Weiler's upright brooms and whisks are durable enough to meet all industrial and commercial applications.



Sweeping plastic and metal chips in a tool room

P UPRIGHT BROOMS - Ideal for sweeping floors, reaching into corners, cleaning ceilings, etc.

Description	Fill Material	Trim Length	Overall Length	Standard Pack	Item Number
Light Industrial Brooms - Better Quality					
5 sews - 7/8" handle	Corn & Fiber	17"	57"	12	44548
5 sews - 7/8" handle	100% Corn	15"	56"	12	44009
6 sews - 1-1/8" handle	100% Black Corn	16"	56"	12	70304
Janitor's Broom - Best Quality					
5 sews - 1-1/8" handle Wire banded	Corn & Fiber	17"	57"	12	70308
Warehouse Broom - Heavy-Duty					
4 sews - 1-1/8" handle Wire banded	Corn & Fiber	18"	57"	12	44008



P ANGLE BROOM - Angled trim allows access to corners, under low cabinets and other hard-to-reach areas.

Description	Fill Material	Trim Length	Overall Length	Standard Pack	Item Number
Large Plastic 12" sweep face	Flagged Plastic	7-1/2"-6"	54"	12	44305



V VORTEC PRO® ANGLE BROOM - Reliable and efficient broom at a value price.

Description	Fill Material	Trim Length	Overall Length	Standard Pack	Item Number
Small Plastic 8" sweep face	Flagged Plastic	3-7/8"-4-1/2"	54"	12	75160

P CAP BROOMS - Metal top for added durability. Ideal for wet or dry applications.

Description	Fill Material	Trim Length	Overall Length	Standard Pack	Item Number
Metal Cap - Wire banded 12" sweep face	Palmyra	10"	55"	6	44007
Metal Cap - Wire banded 12" sweep face	Brown Poly	10"	55"	6	70325
Track & Switch Steel chisel point on handle end	Palmyra	8"	55"	6	70324



V VORTEC PRO LOBBY BROOMS - Reliable and efficient brooms at a value price.

Description	Fill Material	Trim Length	Overall Length	Standard Pack	Item Number
Toy/Lobby - 3 sews, 7/8" handle	Corn & Fiber	11"	40"	12	70300



P WHISK BROOMS - For fast, efficient clean-up.

Use	No. of Sews	Fill Material	Trim Length	Overall Length	Std. Pack	Item No.
General purpose - all applications	3	Corn & Fiber	10"	12-1/2"	12	44266
Sweeping coarse & heavy material	2	Palmetto	7"	9-1/4"	12	44099
Coarse sweeping of hot chips	-	Bassine	5-1/4"	10-1/4"	12	44103



COATED ABRASIVES
NON-WOVEN ABRASIVES
POWER BRUSHES
NYLON BRUSHES
PACKAGED ITEMS
MAINTENANCE

Key:

P Performance line
Industrial Grade

V Value line
Professional Grade

DUSTERS, DUST PANS & SQUEEGEES



Cleaning up oil absorbent from a shop floor.



44003



42213

P COUNTER DUSTERS - For clean up in hard-to-reach areas.

Fill Material	Trim Length	Brush Length	Overall Length	Block Type	Std. Pack	Item No.
Horsehair						
Horsehair	2-1/4"	8"	13-1/4"	Wood	12	44003
	2-1/4"	9"	14-1/4"			44351
Black Horsehair and Fiber Mix	2-1/2"	8"	13-1/2"	Wood	12	71019
Synthetic						
Flagged Silver Polystyrene	2-1/2"	8"	13-1/4"	Wood	12	44354
Black Polystyrene	2-1/2"	8"	13-1/4"	Wood	12	25252
Orange Polystyrene	2"	9"	14"	Foam	12	42213
Natural Fiber						
Black Tampico	2-1/2"	8"	13-1/4"	Wood	12	25251
Tri-colored Tampico	2-1/2"	8"	13-1/2"	Wood	12	44004

P DUST PANS - Durable, industrial grade - For quick clean-ups.

Description	Height	Width	Depth	Std. Pack	Item No.
Heavy-duty 20 gauge steel Black enamel finish	-	12"	13-1/2"	12	71078
Extra wide - Heavy-duty 20 gauge steel; Black enamel finish	-	16"	15"	12	71079

71078



71077



V VORTEC PRO® DUST PAN - Reliable and efficient pans at a value price.

Description	Height	Width	Depth	Std. Pack	Item No.
Molded plastic	-	12-1/4"	12"	12	71077



45507



45510



45500

P FLOOR SQUEEGEES - Heavy-duty construction, iron handle socket.

Description	Length	Type	Standard Pack	Item Number
Black rubber blade for rough, heavy use	18"	Straight	6	45506
	24"			45507
	30"			45534
	36"			75202
Black rubber blade for rough, heavy use	24"	Curved	6	45510
	30"			45535
	36"			45511

P WINDOW SQUEEGEES - Rust-proof handle socket and frame.

Description	Length	Standard Pack	Item Number
One piece frame with hard rubber section joined with a soft, red rubber blade.	6"	12	45537
	12"		45500
	14"		45538 •

NOTE



• Non-stock product, contact Customer Service for lead times and minimum order quantities.

- All squeegees require a tapered tip handle.
- Handle No. 44020 (1-1/8" x 60") recommended for use with all Squeegees.
- Handle not included in price - order handle separately.

VEHICLE CARE PRODUCTS

Weiler's line of vehicle care brushes meets the cleaning needs of car and truck fleets. Brushes are also popular in the marine industry. All products are designed to provide professional results.



Washing a car with a vehicle wash brush and fountain tube handle.

P VEHICLE WASH BRUSHES - Protective bumper - Foam block with two handle holes.

Block Size	Fill Material	Trim Length	Standard Pack	Item Number
9-1/2" x 2-3/4"	Grey Fiber	2-1/2"	12	44318*
9-1/2" x 2-3/4"	Flagged White Polystyrene	2-1/2"	12	44510
9-1/2" x 2-3/4"	Flagged Orange Polystyrene	2-1/2"	12	42210

* May scratch smooth or high gloss surfaces, use polystyrene filled products for these surfaces.



44510

P SCHOOL BUS BRUSH - Easily sweeps between school bus seats. Lacquered hardwood block with one threaded handle hole. Use handle #44571.

Block Size	Fill Material	Trim Length	Standard Pack	Item Number
10" x 2-1/2"	Flagged Silver-grey Polystyrene	3"	12	70312



70312

P UPHOLSTERY/SPOTTING BRUSH - Shaped plastic handle

Wet & dry cleaning, prespotting, carpet touch-up, etc.

Block Size	Fill Material	Trim Length	Overall Length	No. of Rows	Std. Pack	Item Number
8-1/2" x 2-9/16"	.016 Crimped Polypropylene	5/8"	8-1/2"	8 x 9	12	44307



44307

P SPOKE BRUSH - Ideal for cleaning spokes or confined spaces.

Length of Brush Part	Fill Material	Brush Part	Overall Length	Standard Pack	Item Number
10"	White Tampico	2-7/8" tapered to 1-1/4"	15"	12	44315



44315

P TIRE CLEANING BRUSHES - Foam block - Used for cleaning sidewalls of tires.

Block Size	Fill Material	Trim Length	Overall Length	No. of Rows	Std. Pack	Item No.
8-1/2" x 2-9/16"	.008 Brass	5/8"	8-1/2"	8 x 9	12	99593
7" x 1-9/16"	.008 Brass	5/8"	7"	6 x 8	12	73156



99593



73156

Key:

P Performance line
Industrial Grade

V Value line
Professional Grade

COATED ABRASIVES

NON-WOVEN ABRASIVES

POWER BRUSHES

NYLON BRUSHES

PACKAGED ITEMS

MAINTENANCE

SCRUB & UTILITY BRUSHES



Scrubbing a stainless steel sink.

A broad range of high quality scrub and utility brushes are available from Weiler. From quick cleaning to heavy-duty scrubbing, Weiler's brushes are designed to provide the most effective brushing and cleaning action.



44395



44024



44023

P HAND SCRUB BRUSHES - Heavily filled for heavy-duty scrubbing.

Block Size	Fill Material	Trim Length	Block Type	Standard Pack	Item Number
6"	White Polypropylene	1-1/8"	Iron Style - Plastic	12	44395
7-1/4"	Palmyra	1"	Square - Wood	24	72034 •
8"	White Tampico	1-1/8"	Square - Wood	12	44024
	White Tampico	1"			72058*
	Palmyra	1-1/8"			44025
8-1/4"	White Tampico	1-1/8"	Square - Wood	12	73111+
9"	White Tampico	1-1/8"	Pointed - Wood	12	44023

* Threaded handle hole

+ Tapered handle hole

• Non-stock product, contact Customer Service for lead times and minimum order quantities.



44026

P DECK SCRUB BRUSHES - Excellent for scrubbing decks or floors. One threaded and one tapered handle hole. Can be used with threaded handle #44018 or tapered handle #44020.

Block Size	Fill Material	Trim Length	No. of Rows	Block Type	Standard Pack	Item Number
9"	Palmyra	2"	5 x 14	Wood	12	44428
	Tampico					44429
10"	Palmyra	2"	6 x 18	Wood	12	44026
	Tampico					44028
	Polypropylene					44434
12"	Palmyra	2"	6 x 20	Wood	12	44027
	Polypropylene					44438



44434

P BI-LEVEL SCRUB BRUSHES - The bi-level design allows the brush to stay in contact with the surface. Can be used with Perma-Flex handle #44301.

Block Size	Fill Material	Trim Length	Block Type	Standard Pack	Item Number
10"	Stiff Crimped Blue Polypropylene	1-3/4"	Foam	6	44692
10"	Flagged White Polystyrene	2-3/4"	Foam	6	44699
10"	Fine Green Nylex	2-3/4"	Foam	12	44693



44692

P UTILITY SCRUB BRUSHES - For general scrubbing in factories, kitchens, institutions, etc.

Overall Length	Fill Material	Trim Length	Block Type	Standard Pack	Item Number
8"	Palmyra	2"	Wood	12	72086
	Yellow Polypropylene				44013
	White Tampico				44014
20"	Palmyra	2"	Wood	12	72101
	Yellow Polypropylene				44016
	White Tampico				44017



44014

P UTILITY SCRUB BRUSHES - Chemical and water resistant, will not warp or crack.

Overall Length	Fill Material	Trim Length	Block Type	Standard Pack	Item Number
8"	Palmyra	2"	Foam	12	79101
	Yellow Polypropylene				79120
	White Tampico				79100
20"	Palmyra	2"	Foam	12	79107
	Yellow Polypropylene				79109
	White Tampico				44663



44016



79120



79107

P UTILITY SCRUB BRUSHES - Designed for high temperature cleaning, ideal for food service.

Overall Length	Fill Material	Trim Length	Block Type	Standard Pack	Item Number
8"	White Nylon	2"	Plastic	12	44416
20"	White Nylon	2"	Plastic	12	44418



44418

SCRUB & UTILITY BRUSHES



Removing stubborn dirt, grime and mildew from a tiled surface with a grout detail brush.

P **GROUT DETAIL BRUSH** - Use for removing stubborn dirt, grime and mildew from tiled surfaces.

Block Size	Fill Material	Trim Length	Standard Pack	Item Number
8-1/2"	Stiff Black Nylon	7/8"	24	73233

P **VAT BRUSH** - For valves, outlets, small tanks, beverage dispensers & coffee urns. Can be used with the Perma-Flex handle #44301.

Fill Material	Block Type	Overall Length	Standard Pack	Item Number
White Nylon	White Nylon	8"	1	75570

P **PROFESSIONAL BOWL BRUSHES** - Hardwood handle and natural fiber - For thorough cleaning.

Brush Part	Fill Material	Diameter	Overall Length	Standard Pack	Item Number
6" x 5"	White Tampico	2"	20"	12	44001*
6-1/2"	Tampico	3-1/4"	23"	12	75060

* Foam handle

V **VORTEC PRO® BOWL BRUSH SET** - 2" Trim Length - Reliable and efficient brushes at a value price.

Brush Part	Fill Material	Handle	Overall Length	Standard Pack	Item Number
3-1/2" x 3-3/4"	Polypropylene	Plastic	14-1/2"	6	75000

V **VORTEC PRO NAIL BRUSH** - Great for use in shop or industrial settings.

Block Size	Fill Material	Trim Length	No. of Rows	Block Type	Standard Pack	Item Number
4-3/4" x 1-1/2"	Polypropylene	3/4"	4 x 15	Wood	36	44314

P **BOTTLE WASHING BRUSH** - Brush shape enables access to hard-to-reach areas when cleaning.

Length of Brush Part	Fill Material	Handle	Overall Length	Standard Pack	Item Number
6"	Black Horsehair	Wood	16"	12	99594

P **NYLON TUBE BRUSHES** - Loop handle, Straight black nylon fill.

Diameter	Fill Diameter	Brush Part	Stem Diameter	Overall Length	Standard Pack	Item Number
1/4"	.005	2"	3/32"	6-1/4"	36	44110
3/8"	.005	2"	3/32"	6-1/4"	36	44213
1/2"	.010	3"	1/8"	8-1/2"	36	44111
3/4"	.012	3"	1/8"	8-1/2"	36	44112
1"	.014	4"	5/32"	12-1/4"	36	44113
1-1/4"	.014	4"	5/32"	13"	36	44114
2"	.014	5"	3/16"	16-3/4"	36	44115

P **PERCOLATOR BRUSH** - Straight white nylon
Ideal for internal cleaning in industrial, laboratory and food service.

Diameter	Fill Diameter	Brush Part	Stem Diameter	Overall Length	Standard Pack	Item Number
7/16"	.010	3-1/2"	5/32"	11-1/2"	10	44316

V **VORTEC PRO® BOOT BRUSH** - Reliable and efficient brush at a value price.

Size	Description	Item Number
9" x 6"	Boot Cleaning Brush - Metal Frame - Wood Block - Black Nylon Fill	44391



COATED ABRASIVES
NON-WOVEN ABRASIVES
POWER BRUSHES
NYLON BRUSHES
PACKAGED ITEMS
MAINTENANCE

Key:

P Performance line
Industrial Grade

V Value line
Professional Grade

MOPS & DUSTING BRUSHES



Use the Combo Bucket with 12 to 32 oz. mop heads

P **WET MOP HEADS** - Durable, ideal for all-purpose cleaning. Can be laundered.

Weight	Material	Standard Pack	Item Number
Cut End			
16 oz.	8-ply tight twist cotton	12	75102
20 oz.			75103
24 oz.			75104
32 oz.			75105

P **WET MOP HANDLES** - Industrial Grade. Hardwood handle with plated metal heads.

Description	Size	Standard Pack	Item Number
Quick-Change Plastic Head	54" x 15/16"	12	75140
Screw Type	54" x 1-1/8"	12	75131
Spring Type	54" x 1-1/8"	12	75132
Jaw Type	54" x 1-1/8"	12	75130



75102

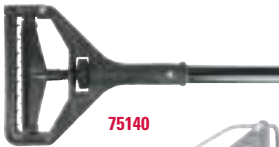

75140

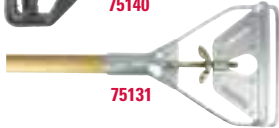

75131



75109

P **ONE-PIECE COTTON DECK MOPS** - Industrial grade. Mop head securely tied to handle.

Description	Weight	Standard Pack	Item Number
#16	16 oz.	12	75109
#24	24 oz.	12	75110

V **VORTEC PRO® COMBO BUCKET** - One-piece construction that will not rust, fade, crack, peel, chip, dent or warp. Wringer fits all sizes of plastic or metal buckets.

Bucket Size	Wringer	Standard Pack	Item Number
36 qt.	12-32 oz.	1	36666



36666

P **RADIATOR BRUSHES** - 24" Overall Length. Ideal for cleaning radiators and narrow, hard-to-reach places.

Fill Material	Type	Brush Part	Trim Length	Overall Length	Std. Pack	Item No.
Black Horsehair	Foam Handle	9-1/2"	2-1/2"	23-13/16"	12	73050
Black Horsehair	Twisted-in-wire handle	7-1/2"	2-1/2"	24-11/16"	12	73055



73050



73055

P **WALL DUSTING BRUSH** - For dusting ceilings, valances, high moldings and other hard-to-reach places. Twisted-in-wire construction with plastic handle.

Fill Material	Overall Length	Trim Length	Standard Pack	Item Number
Horsehair	12" x 5"	2-3/4"	2	71076



71076

Key:

P Performance line
Industrial Grade

V Value line
Professional Grade

MASONRY & APPLICATOR BRUSHES

Weiler's full line of Masonry & Applicator Brushes covers everything from the ground up - cement finishing and stippling brushes for texturing and applying cement and asphalt; whitewashing and masonry brushes for applying cement, water paints and liquid waterproofing materials on concrete block and masonry walls; smoothing brushes for applying wallpaper; and roof brushes for spreading roofing tar and coatings.



Applying waterproofing material with a masonry brush.

P BLOCK-TYPE ROOF BRUSHES - For application of roof coatings.

Can be used with tapered handle #44574 or threaded handle #75527.

Block Size	Fill Material	Trim Length	No. of Knots	Standard Pack	Item Number
7"	White Tampico One tapered handle hole	2"	5	12	44011
7"	White Tampico One threaded handle hole	2"	5	12	73195

P MASONRY BRUSHES -

Useful tools for applying cement, waterpaints and liquid waterproofing materials on masonry walls. Handle attached.

Block Size	Fill Material	Trim Length	Overall Length	No. of Rows	Standard Pack	Item Number
7"	White Tampico	3-1/4"	11"	2	12	44032
6"	Solvent Resistant Polypropylene	3-1/4"	11-1/2"	3	12	74020
4"	White Tampico	3"	10-3/4"	4	12	74004
6-1/2"	White Tampico	3-1/2"		4		44031
6"	White Tampico	3"	10-1/2"	5	12	74002
6-1/2"	White Tampico	4"	11-3/4"	5		44448



44011



44448



44034

P WHITEWASH BRUSHES - Two tapered handle holes allow user to choose the correct brush angle needed.

Can be used with tapered handle #75528.

Block Size	Fill Material	Trim Length	No. of Rows	Standard Pack	Item Number
6"	White Tampico	2-5/8"	2	12	74048
7"	White Tampico	2-5/8"	2	12	44034 74053*

* Includes a 12" tapered wood handle.

P ACID BRUSH - Detachable handle - For the application of Kalsomine, cold water, acid and water repellents to concrete and other rough surfaces.

Block Size	Fill Material	Trim Length	No. of Rows	Standard Pack	Item Number
7"	White Tampico	3-1/2"	3	12	74015



74015

P ACID SCRUB BRUSH - Hardwood block - Tapered handle hole

Recommended for applying sealcoating, cement slurry, water-proofing, etc.

Block Size	Fill Material	Trim Length	Standard Pack	Item Number
8-1/4" x 2-3/4"	White Tampico	1-1/8"	12	73111

NOTE: Handle not included - can be used with tapered handle #44574.



73111

P CEMENT FINISHING BRUSHES - Hardwood block - Ideal for creating texture to newly poured cement and for applying coatings on asphalt or concrete. Use handle #44303.

Block Length	Fill Material	Trim Length	No. of Knots	Standard Pack	Item Number
24"	Black Polypropylene	3-1/4"	3	6	79252
36"	Black Polypropylene	3-1/4"	3	6	79253



79252

P DRIVEWAY COATERS - For applying blacktop driveway and parking lot dressings; asphalt, sealers or roof coatings.

Block Size	Fill Material	Trim Length	Standard Pack	Item Number
10"	Black Tampico	2-5/8"	12	73180



73180

NOTE

- Handle No. 75527 (7/8" x 48") recommended for Driveway Coaters.
- Handle not included in price - order handle separately.

COATED ABRASIVES

NON-WOVEN ABRASIVES

POWER BRUSHES

NYLON BRUSHES

PACKAGED ITEMS

MAINTENANCE

SCRATCH BRUSHES



Removing excess concrete from the surface of a steel support plate.

Weiler's extensive Scratch Brush offering includes many block and handle types and sizes. The wide variety of fill materials available assures the right brush for the right job. Common applications are cleaning dirt, rust, scale, chips and paint; plating and welding operations.

P CURVED HANDLE SCRATCH BRUSHES - **Hardwood block** - Ideal for cleaning and prepping surfaces.

Block Size	Brush Length	Number of Rows	Trim Length	Standard Pack	Item Number
.012 Steel Wire					
13-3/4" x 1-1/8"	5-1/4"	3 x 14	1-1/4"	12	44594*
14" x 7/8"	5-1/2"	3 x 19	1-3/16"	12	44053 V
14" x 1-1/8"	6"	4 x 18	1-3/16"	12	44056
.012 Steel Wire with Scraper					
14" x 7/8"	5-1/2"	3 x 19	1-3/16"	12	44055
14" x 1-1/8"	6"	4 x 18	1-3/16"	12	44058
.012 Stainless Steel Wire					
13-3/4" x 1-1/8"	5-1/4"	3 x 14	1-1/4"	12	44432*
14" x 7/8"	5-1/2"	3 x 19	1-3/16"	12	44054 V
14" x 1-1/8"	6"	4 x 18	1-3/16"	12	44057

* V-Groove

P V Display Packed & Vending Ready product available, add P or V to the end of item number when placing order.



V VORTEC PRO® CURVED HANDLE SCRATCH BRUSHES -

Reliable and efficient brushes at a value price.

Block Size	Brush Length	Number of Rows	Trim Length	Standard Pack	Item Number
.012 Steel Wire					
13-1/2" x 1"	6"	3 x 19	1"	12	25150
14" x 1-1/8"	6"	4 x 18	1"	12	25201
.012 Stainless Steel Wire					
13-1/2" x 1"	6"	3 x 19	1"	12	25154
14" x 1-1/8"	6"	4 x 18	1"	12	25202



P SHOE HANDLE SCRATCH BRUSHES - **Hardwood block** - Ideal for cleaning and prepping surfaces.

Block Size	Brush Length	Number of Rows	Trim Length	Standard Pack	Item Number
.012 Steel Wire					
10" x 3/8"	5"	1 x 17	1-1/16"	12	44100
10" x 5/8"	5"	2 x 17	1-3/16"	12	44061
10" x 1-1/8"	5"	4 x 16	1-3/16"	12	44063 V
11"	5"	4 x 16	1-3/16"	12	73217 •
.012 Steel Wire with Scraper					
10" x 1-1/8"	5"	4 x 16	1-3/16"	12	44065
.012 Stainless Steel Wire					
10" x 3/8"	5"	1 x 17	1-1/16"	12	44101
10" x 3/8"	5"	1 x 17	3/4"	12	44235
10" x 5/8"	5"	2 x 17	1-3/16"	12	44062
10" x 1-1/8"	5"	4 x 16	1-3/16"	12	44064 V
11"	5"	4 x 16	1-3/16"	12	44299 •
.012 Brass Wire					
11"	5"	4 x 16	1-1/4"	12	73218 •

• Plastic block

P V Display Packed & Vending Ready product available, add P or V to the end of item number when placing order.

V VORTEC PRO SHOE HANDLE SCRATCH BRUSHES -

Reliable and efficient brushes at a value price.

Block Size	Brush Length	Number of Rows	Trim Length	Standard Pack	Item Number
.012 Steel Wire					
10" x 1"	5"	4 x 16	1"	12	25100
.012 Stainless Steel Wire					
10" x 1"	5"	4 x 16	1"	12	25104



P HEAVY-DUTY SCRATCH BRUSH WITH SCRAPER - .012 Steel Wire

Ideal for cleaning and prepping surfaces.

Block Size	Brush Length	Number of Rows	Trim Length	Standard Pack	Item Number
11-1/2" x 1-1/2"	5-1/2"	4 x 11	1-1/2"	12	44069



V VORTEC PRO® HEAVY-DUTY SCRATCH BRUSH WITH SCRAPER - .012 Steel Wire

Reliable and efficient brushes at a value price.

Block Size	Brush Length	Number of Rows	Trim Length	Standard Pack	Item Number
11-1/2" x 1-1/2"	5"	4 x 11	1-5/8"	12	25211

P PLATER'S BRUSHES - Hardwood block - For general cleaning in the plating, metal finishing, aircraft and missile industries. Also used with inert arc aluminum welding.

Block Size	Brush Length	Number of Rows	Trim Length	Standard Pack	Item Number
Tampico					
13" x 1-1/4"	5-1/4"	4 x 18	1"	12	44076
Nylon					
13" x 1-1/8"	5-1/4"	4 x 18	1"	12	44077
.006 Steel Wire					
10" x 1-1/8"	5"	4 x 16	1"	12	44117 •
13" x 7/8"	5-1/2"	3 x 19	1"	12	44116
.006 Stainless Steel Wire					
10" x 1-1/8"	5"	4 x 18	1"	12	44240
13" x 7/8"	5-1/2"	3 x 19	1"	12	44660
13" x 1-1/8"	5-1/2"	4 x 19	1"	12	44232
.006 Brass Wire					
10" x 1-1/8"	5"	4 x 18	1"	12	44119
13" x 7/8"	5-1/2"	3 x 19	1"	12	44118

• Non-stock product, contact Customer Service for lead times and minimum order quantities.



P SMALL HAND SCRATCH BRUSHES - Ideal for cleaning and prepping surfaces.

Block Size	Block	Number of Rows	Wire Size	Trim Length	Standard Pack	Item Number
Stainless Steel Wire						
7-1/2" x 1/2"	Plastic	3 x 7	.006	1/2"	36	44075 V
7-1/2" x 1/2"	Wood	3 x 7	.006	1/2"	36	44167 V
7-3/4" x 3/8"	Wood	3 x 7	.006	1/2"	36	44551 *
8-3/4" x 1/2"	Wood	2 x 9	.006	5/8"	36	95013
Straight Brass Wire						
7-1/2" x 1/2"	Wood	3 x 7	.006	1/2"	36	44189 V
Crimped Brass Wire						
6" x 1/2"	Wood	3 x 10	.005	5/8"	72	44619
8-3/4" x 1/2"	Wood	2 x 9	.008	5/8"	36	95014
Crimped Aluminum						
6-3/4" x 1-5/8"	Wood	6 x 9	.008	5/8"	12	95151
8-3/4" x 1/2"	Wood	2 x 9	.008	5/8"	36	44251
Straight Black Nylon						
6-1/2" x 1/2"	Plastic	4 x 15	.010	1/2"	24	99383
7-1/2" x 1/2"	Wood	3 x 7	.012	1/2"	36	44637
White Nylon						
7-1/2" x 1/2"	Plastic	3 x 7	.016	1/2"	36	44609
Double-Sided Brass/White Nylon						
7-1/2" x 1/2"	Plastic	3 x 7	.006/.016	1/2"	24	44731
Double-Sided Brass/Stainless Steel						
7-1/2" x 1/2"	Plastic	3 x 7	.006/.006	1/2"	24	44732
Double-Sided Stainless Steel/White Nylon						
7-1/2" x 1/2"	Plastic	3 x 7	.006/.016	1/2"	24	44733

*Wire drawn

P V Display Packed & Vending Ready product available, add P or V to the end of item number when placing order.



WHY WEILER
BONDED ABRASIVES
COATED ABRASIVES
NON-WOVEN ABRASIVES
POWER BRUSHES
NYLON BRUSHES
PACKAGED ITEMS
MAINTENANCE

Key:

P Performance line
Industrial Grade

V Value line
Professional Grade



44806



44810

V VORTEC PRO® SMALL HAND SCRATCH BRUSHES - Reliable and efficient brushes at a value price.

Block Size	Handle	Number of Rows	Trim Length	Standard Pack	Item Number
.006 Stainless Steel Wire					
7-1/2" x 1/2"	Wood	3 x 7	1/2"	36	44805
7-1/2" x 1/2"	Plastic	3 x 7	1/2"	36	44806
.006 Straight Brass Wire					
7-1/2" x 1/2"	Wood	3 x 7	1/2"	36	44810



44067

P BLOCK TYPE SCRATCH BRUSHES - For rugged cleaning on bricks, stone and similar large flat areas.

Block Size	Fill Material	Brush Part	Number of Rows	Trim Length	Standard Pack	Item Number
7-1/4" x 2-5/8"	.012 Round Wire - Curved Face	7"	9 x 21	1-3/16"	12	44066
7-1/4" x 2-1/4"	.014 Round Wire - Flat Face	7"	6 x 19	1-5/8"	12	44067



44451

P WIRE DUSTER - For cleaning chips, borings, solder, rust, dirt & corrosion from castings.

Block Size	Fill Material	Handle Length	Number of Rows	Trim Length	Standard Pack	Item Number
3" x 1-1/8"	.012 Steel	5-3/4"	4 x 8	2-1/2"	12	44451



44260

P FILE CARD BRUSH - Waxed hardwood block. Use for file cleaning or to roughen and prepare surface material prior to sweating and soldering.

Overall Length	Fill Material	Brush Part	Trim Length	Standard Pack	Item Number
8-1/4"	.012 Steel	1-5/8" x 4"	1/4"	12	44260



44074

P METAL CHIP BRUSH - Small stiff wire brush for brushing hot metal. Can be exposed to flames without burning.

Overall Length	Fill Material	Trim Length	Face Width	Standard Pack	Item Number
5-1/2"	.012 Steel	1-1/2"	1-1/4"	12	44074

FLUE BRUSHES

Flue Brushes are designed and engineered from black oil-tempered wire. Flue brushes are available in single spiral and double spiral construction. Other fill materials and sizes available by special order. Contact Customer Service for details.

APPLICATIONS

Provides increased conformability and long life when:

- Pipe cleaning
- Flue cleaning
- Boiler tube cleaning



Cleaning boiler pipes with a flue brush.

P **FLUE BRUSHES** - Filled with .012 round wire and fitted with 1/4" x 2" NPT pipe nipple. For internal cleaning of pipes and flues.

Brush Diameter	Brush Length	Overall Length	Standard Pack	Item Number
Single Spiral				
7/8"	4-1/2"	7-1/2"	1	44124 •
1"	4-1/2"	7-1/2"	1	44125
1-1/4"	4-1/2"	7-1/2"	1	44047 •
1-1/2"	4-1/2"	7-1/2"	1	44128
1-3/4"	4-1/2"	7-1/2"	1	44048 •
2"	4-1/2"	7-1/2"	1	44131
2-1/2"	4-1/2"	7-1/2"	1	44133
3"	4-1/2"	7-1/2"	1	44135
3-1/2"	4-1/2"	7-1/2"	1	44137
4"	4-1/2"	7-1/2"	1	44139
Double Spiral				
1"	4-1/2"	7-1/2"	1	44149
1-1/4"	4-1/2"	7-1/2"	1	44035
1-1/2"	4-1/2"	7-1/2"	1	44150
1-3/4"	4-1/2"	7-1/2"	1	44036
2"	4-1/2"	7-1/2"	1	44152
2-1/4"	4-1/2"	7-1/2"	1	44037
2-1/2"	4-1/2"	7-1/2"	1	44154
2-3/4"	4-1/2"	7-1/2"	1	44038 •
3"	4-1/2"	7-1/2"	1	44156
4"	4-1/2"	7-1/2"	1	44169
4-7/8"	4-1/2"	7-1/2"	1	44159

• Non-stock product, contact Customer Service for lead times and minimum order quantities.

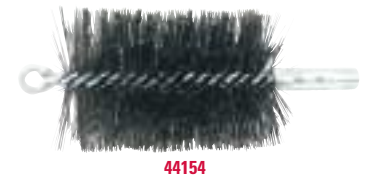

P **FLUE BRUSH EXTENSION ROD** - One 1/4" male pipe nipple and one 1/4" female pipe coupling allows user to extend flue brush.

Description	Standard Pack	Item Number
36" Fiberglass Extension Rod	1	95925



NOTE

"Pipeline" Flue Brushes By Special Order Only.

- Heavy-duty. Exact size diameter. Rugged double stem, single spiral.
- Fitted with 1/4" pipe nipple. Available in diameters of 1-5/8" - 15".

Key:

P Performance line
Industrial Grade

V Value line
Professional Grade

COATED ABRASIVES

NON-WOVEN ABRASIVES

POWER BRUSHES

NYLON BRUSHES

PACKAGED ITEMS

MAINTENANCE

TUBE FITTING BRUSHES

Several configurations and sizes of Tube Fitting Brushes are available for cleaning and deburring copper, internal and external tube fittings. The handy 4-in-1 tube fitting brush cleans both outside and inside diameters of multiple tube sizes.



Cleaning the inside of a copper fitting prior to soldering.

P **INTERNAL TUBE FITTING BRUSHES - Wire Fill** - For internal cleaning and deburring of copper tube fittings. Also used in trucking and marine industries as a light socket cleaning brush.

Pipe Size	Actual Brush Diameter	Brush Length	Overall Length	Handle Length	Standard Pack	Item Number
1/8"	1/4"	1"	6-1/2"	3-1/4"	12	44078
1/4"	3/8"	1"	6-1/2"	3-1/4"	12	44079
3/8"	1/2"	1"	6-1/2"	3-1/4"	12	44080 V
1/2"	5/8"	1"	6-1/2"	3-1/4"	12	44081
5/8"	3/4"	1"	6-1/2"	3-1/4"	12	44082
3/4"	7/8"	1"	6-1/2"	3-1/4"	12	44083
7/8"	1"	1"	6-1/2"	3-1/4"	12	44084
1"	1-1/8"	1"	6-1/2"	3-1/4"	12	44085
1-1/4"	1-3/8"	1"	6-1/2"	3-1/4"	12	44086
1-1/2"	1-5/8"	1-1/2"	6-1/2"	3-1/4"	6	44087

P V Display Packed & Vending Ready product available, add P or V to the end of item number when placing order.



P **4-IN-1 TUBE FITTING BRUSH - ONE BRUSH REPLACES FOUR! - Steel Wire**

Cleans the outside and inside diameters of 1/2" and 3/4" tubes and fittings. Use for soldering prep, deburring, drill hole cleaning and cleaning battery terminals.

Tube Inside Diameter	Tube Outside Diameter	Standard Pack	Item Number
3/4" and 1/2"	7/8" and 5/8"	1	44690

TURBO TUBE™ BRUSHING TOOL - The Turbo Tube Brushing Tool is two brushes in one, so fittings and copper tubing can be easily cleaned without changing tools!

APPLICATIONS

- Fitting brush cleans outside diameter
- Tube brush cleans inside diameter
- Ideal for plumbing and HVAC projects

V **VORTEC PRO® TURBO TUBE BRUSHES** - Clean I.D. and O.D. with the same tool. Rust-proof stainless steel bristles. Reliable and efficient brushes at a value price.



I.D. Size	O.D. Size	Wire Type	Max. RPM	Standard Pack	Item Number
1/2"	5/8"	Stainless	1,000	1	36303
3/4"	7/8"				36304
1"	1-1/8"				36305



SELECTING THE RIGHT BRUSH

P PERFORMANCE LINE (INDUSTRIAL GRADE)

Engineered and manufactured to maximize performance and minimize operating costs. The use of superior construction, the highest quality materials and the most stringent manufacturing processes deliver the lowest cost-of-use and most consistent performance.

V VALUE LINE (PROFESSIONAL GRADE)

Weiler's value line is manufactured using similar product construction and the same exacting standards as other Weiler paint & varnish products, but engineered to provide cost-effective use specifically designed for the professional, providing a cost-effective price. Vortec Pro® paint & varnish products are an economical choice for the construction trades, low volume production shops and light-duty industrial MRO use.

SELECTION GUIDE

Brush Fill	Recommended For	Benefits
China Bristle	All oil based and alkyd paints, stains, varnish urethane & shellac	<ul style="list-style-type: none"> • Softest tip for fewest brush marks • Natural fibers hold paint better than synthetics
Polyester/Nylon blend	All paints and coatings	<ul style="list-style-type: none"> • Most durable material • Precise tipping • Cleans up easily
Polyester	All paints and coatings	<ul style="list-style-type: none"> • Low cost • Does not absorb water

PAINT BRUSH FEATURES

Fill Material:

- Natural China Bristle or Tapered Polyester
- Various sizes of fill material are blended together to create the proper taper.

Flagged Ends:

A split at the end of each tapered fiber of fill material. Bristle is naturally tapered with a flagged tip. Polyester fibers are made tapered and then mechanically processed to form a flagged tip. Flagging allows each tip to pick up more paint and spread it more evenly.

Thickness: The thickness of the brush, measured at the ferrule, will determine the quality level of the brush. The thicker the brush, the more paint pick-up and release.

Ferrule: The metal band that holds the fill material and handle together. All Weiler paint and varnish brushes are made with plated metal ferrules that will not rust or corrode.

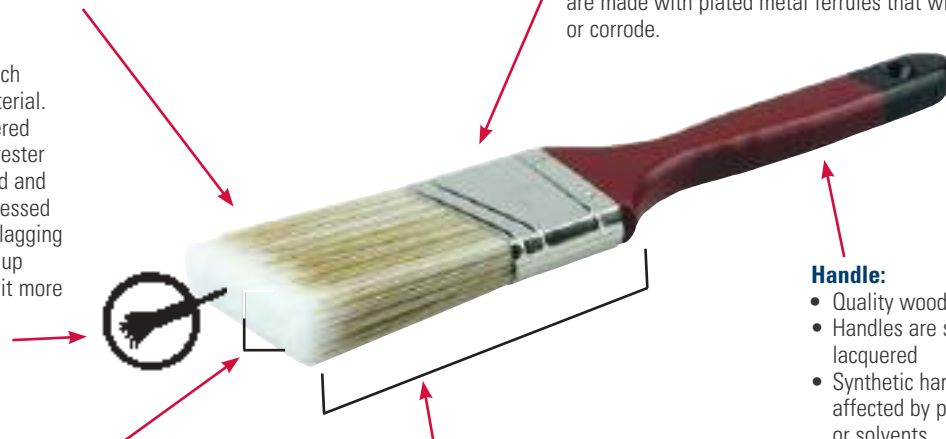

Handle:

- Quality wood or synthetic
- Handles are sanded and lacquered
- Synthetic handles are not affected by paints, varnishes or solvents.
- Comfortable grip for hours of fatigue-free use.

Trim Length: The length of the fill material extending from the ferrule. The longer the trim, the more paint is picked up and released for a quicker, easier job.

PAINT BRUSH CARE

Brushes Used In	Clean With
<ul style="list-style-type: none"> • Oil base paint • Latex paint • Water base paint • Varnish • Shellac 	<ul style="list-style-type: none"> • Turpentine or mineral spirits • Warm soapy water • Warm soapy water • Turpentine or mineral spirits • Alcohol

Note: After cleaning, shake out, comb bristles and hang by handle.

SPECIAL PAINT BRUSHES

The brushes listed in this catalog will cover the major requirements of industry. However, if an application requires another type, size or style of brush, contact your nearest Weiler distributor or Weiler's Customer Experience Team.

WHY WEILER
BONDED ABRASIVES
COATED ABRASIVES
NON-WOVEN ABRASIVES
POWER BRUSHES
NYLON BRUSHES
PACKAGED ITEMS

MAINTENANCE

PROFESSIONAL PAINT & PARTS CLEANING BRUSHES



Applying paint to clap board siding.

These high quality brushes are available in a wide variety of sizes and materials to fill all applications. The Professional Sash Brushes are color coded - Blue Bristle and Red for Polyester/Nylon Blend, and feature painted foam handles in the "beaver tail" style. These handles are attractive and easier to grip, reducing user fatigue. Parts cleaning brushes are ideal for applications such as cleaning carburetors, transmission components, applying adhesives and lubricants.



40002



40059

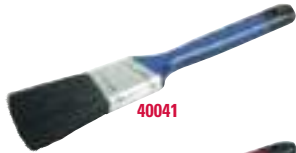

40041

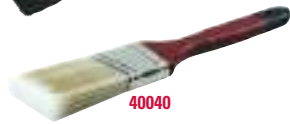

40040



40056



40121



40035



25222

P VARNISH BRUSHES - Comfortable foam grip handle; smooth paint flow.

Width	Thickness	Bristle Length	Overall Length	Standard Pack	Item Number
Black China Bristle - Blue Foam Handle					
1"	7/16"	2"	8-1/2"	12	40000
1-1/2"	1/2"	2-1/4"	8-7/8"	12	40001
2"	9/16"	3"	9-3/4"	12	40002
3"	11/16"	3"	10-1/8"	12	40004
4"	11/16"	3"	10-9/16"	12	40010
Polystyrene/Nylon - Red Foam Handle					
1"	7/16"	2-1/4"	8-13/16"	12	40058
2"	3/4"	2-3/4"	9-15/16"	12	40059
3"	7/8"	3"	10-1/8"	12	40060
4"	7/8"	3"	11"	6	40106

P ANGLED SASH BRUSHES - For trim or cut work like window sills, door frames, etc.

Width	Thickness	Bristle Length	Overall Length	Standard Pack	Item Number
Black China Bristle - Blue Foam Handle					
1-1/2"	7/16"	2-1/4"	10-7/8"	12	40041
2"	1/2"	2-1/4"	10-3/4"	12	40008
Polystyrene/Nylon - Red Foam Handle					
2"	1/2"	2-1/2"	11-1/8"	12	40040

P OVAL SASH BRUSHES - Ideal for cleaning parts, crevices and painting hard-to-reach areas.

Size	Thickness	Bristle Length	Overall Length	Standard Pack	Item Number
Black China Bristle - Plain Foam Handle - Chisel Trim					
#2	7/16"	1-3/4"	8-7/8"	24	40116
#6	13/16"	1-3/4"	9-5/16"	12	40056
#8	15/16"	3"	11-1/8"	12	40020
#10	1-1/16"	3"	11-3/16"	12	40021

P ROUND SASH BRUSHES - Ideal for cleaning parts, crevices and painting hard-to-reach areas.

Size	Thickness	Bristle Length	Overall Length	Standard Pack	Item Number
Grey Bristle - Plain Foam Handle - Flat Trim					
#2	7/16"	1-3/4"	8-3/4"	24	40118
#4	11/16"	2"	8-13/16"	12	40119
#6	13/16"	2"	10-1/16"	12	40120
#8	15/16"	2-1/4"	10-9/16"	12	40121

P PARTS CLEANING BRUSHES - Stainless steel ferrule - Heavily filled.

Thickness	Fill Material	Bristle Length	Overall Length	Standard Pack	Item Number
Plain Foam Handle - Chisel Trim					
1"	Polypropylene	2-1/2"	10-11/16"	12	40035
1"	Tampico	2-3/4"	11-1/8"	12	40036

V VORTEC PRO® PARTS CLEANING BRUSHES - Reliable and efficient brushes at a value price.

Thickness	Fill Material	Bristle Length	Overall Length	Standard Pack	Item Number
Plain Foam Handle - Chisel Trim					
15/16"	Nylon	2-1/2"	11-3/16"	12	25221
1"	Tampico	2-3/4"	11-3/8"	12	25222

• Non-stock product, contact Customer Service for lead times and minimum order quantities.

CHIP AND OIL & INDUSTRIAL PAINT BRUSHES

V VORTEC PRO® CHIP AND OIL BRUSHES - Reliable and efficient brushes at a value price.

Width	Thickness	Bristle Length	Overall Length	Standard Pack	Item Number
White Bristle - Wood Handle					
1/2"	5/16"	1-1/2"	7-3/16"	36	40177
1"	5/16"	1-1/2"	7-3/16"	36	40179
1-1/2"	5/16"	1-1/2"	7-1/16"	24	40180
2"	5/16"	1-1/2"	7-5/8"	24	40181
2-1/2"	3/8"	1-1/2"	7-15/16"	12	40182
3"	3/8"	1-1/2"	8-1/4"	12	40183
4"	5/8"	1-3/4"	8-3/4"	12	40184
4"	3/8"	1-3/4"	8-1/2"	12	40185
Black Bristle - Plastic Handle					
1/2"	1/4"	1-5/8"	7-1/8"	30	40160
1"	5/16"	1-5/8"	7-5/16"	30	40161
1-1/2"	5/16"	1-5/8"	7-3/8"	30	40162
2"	5/16"	1-5/8"	7-3/4"	20	40163
2-1/2"	3/8"	1-3/4"	7-3/4"	20	40164
3"	3/8"	1-3/4"	7-15/16"	10	40165
4"	11/16"	2"	8-1/2"	10	40166
Grey China Bristle - Plastic Handle					
1/2"	1/4"	1-1/2"	7-1/8"	48	40026
1"	5/16"	1-1/2"	7-5/8"	36	40027
1-1/2"	5/16"	1-1/2"	7-5/8"	24	40028
2"	3/8"	1-1/2"	7-7/8"	24	40029
3"	1/2"	1-1/2"	8-9/16"	12	40031
4"	11/16"	1-1/2"	8-13/16"	12	40032
Black Polypropylene - Red Plastic Handle					
1"	5/16"	1-3/4"	7-9/16"	36	40137
2"	3/8"	1-3/4"	7-15/16"	24	40139
3"	1/2"	1-3/4"	9-3/16"	12	40140
4"	11/16"	2-3/4"	9-5/8"	12	40141

P INDUSTRIAL VARNISH BRUSHES - Heavily-filled brush with comfortable handle in a variety of sizes.

Width	Thickness	Bristle Length	Overall Length	Standard Pack	Item Number
Black Bristle - Black Plastic Handle					
1"	3/8"	1-3/4"	7-3/4"	36	40089
2"	7/16"	1-3/4"	8"	12	40074
3"	1/2"	2"	8-13/16"	12	40103
4"	5/8"	2-3/4"	9-7/8"	12	40104
Black Polyester - Red Plastic Handle					
1"	3/8"	2"	8"	36	40107
2"	7/16"	2"	8-1/2"	12	40109
3"	1/2"	2"	9-1/4"	12	40110
4"	11/16"	2-3/4"	9-7/8"	12	40111

P BENT RADIATOR BRUSH - Ideal for painting radiators and other hard-to-reach areas.

Width	Thickness	Bristle Length	Overall Length	Standard Pack	Item Number
Black Bristle - Wood Handle					
2"	9/16"	2-1/4"	19-1/2"	12	95502

V VORTEC PRO® FOAM APPLICATOR BRUSHES - Reliable and efficient brushes at a value price. Not recommended for use with lacquer, shellac or solvents.

Width	Thickness	Foam Length	Overall Length	Standard Pack	Item Number
Wood Handle					
1"	5/8"	2-5/8"	6-3/8"	50	99801
2"	5/8"	2-5/8"	6-1/2"	50	99805
3"	7/16"	2-5/8"	6-1/2"	40	99806

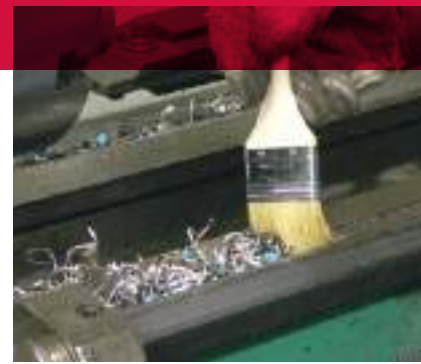

Removing chips from the ways of a lathe.



40181



40161



40029



40141



40074



40109



95502



99806

COATED ABRASIVES

NON-WOVEN ABRASIVES

POWER BRUSHES

NYLON BRUSHES

PACKAGED ITEMS

MAINTENANCE

Key:

P Performance line
Industrial Grade

V Value line
Professional Grade

MARKING, GLUE & ACID BRUSHES



Applying flux to a copper tube prior to soldering.

P RED SABLE WATERCOLOR BRUSHES - Seamless ferrule. Pointed tip - Round black handle

Size	Diameter	Trim Length	Overall Length	Standard Pack	Item Number
3/0	3/64"	1/4"	7"	12	41000
0	1/16"	5/16"	7-1/4"	12	41001
2	3/32"	7/16"	7-3/8"	12	41002
4	1/8"	5/8"	7-5/8"	12	41003

P BLACK BRISTLE MARKING BRUSHES - Long, lacquered handle

Size	Diameter	Trim Length	Overall Length	Standard Pack	Item Number
1	1/8"	3/4"	11-7/8"	12	41004
2	5/32"	15/16"	12"	12	41005
4	7/32"	1-1/8"	12-1/2"	12	41007
5	1/4"	1-1/4"	12-1/2"	12	41008
6	9/32"	1-3/8"	12-3/4"	12	41009

P FLAT MARKING BRUSHES - Ox hair - Single stroke - Round black handle

Width	Trim Length	Overall Length	Standard Pack	Item Number
1/4"	7/8"	7-7/8"	12	41018
1/2"	1"	8-3/4"	12	41019
3/4"	1-1/4"	8-3/4"	12	41020 •
1"	1-3/8"	9-3/8"	12	41021

P FITCH BRUSHES - Black china bristle - Chiseled edge - Clear lacquered handle

Width	Trim Length	Overall Length	Standard Pack	Item Number
1/2"	1-1/16"	12-3/8"	12	41023
3/4"	1-5/16"	12-7/8"	12	41024 •

P LACQUERING BRUSHES - Seamless aluminum ferrule - Camel hair - Round black handle

Size	Diameter	Trim Length	Overall Length	Standard Pack	Item Number
1	5/32"	11/16"	7-1/2"	12	41010
3	7/32"	13/16"	8"	12	41011
5	1/4"	1-1/8"	8-3/4"	12	41012 •
6	5/16"	1-3/16"	8-7/8"	12	41013 •

P BRIDLED GLUE BRUSHES - Grey china bristle - Steel ferrule - Long foam handle

Diameter	Trim Length	Overall Length	Standard Pack	Item Number
7/16"	1-7/16"	8-1/4"	36	40077
13/16"	1-3/4"	9-3/8"	24	40078 •

P ACID/FLUX BRUSHES - Horsehair - Tin ferrule

Width	Trim Length	Overall Length	Standard Pack	Item Number
5/16"	3/4"	5-3/4"	144	44088 V
3/8"	3/4"	5-3/4"	144	44089 V
1/2"	3/4"	5-3/4"	144	44090 V

P V Display Packed & Vending Ready product available, add P or V to the end of item number when placing order.

P STENCIL BRUSHES - China bristle - Seamless steel ferrule - Lacquered wood handle

Diameter	Bristle Length	Overall Length	Standard Pack	Item Number
1"	1-3/8"	5-1/2"	12	40080
2"	1-3/4"	6-3/8"	12	40082

P DOPE BRUSHES - With hanger for coating applications in drilling operations.

Brush Part	Fill Material	Diameter	Overall Length	Standard Pack	Item Number
4"	Mixed	2"	16"	24	44261
	Tampico	3"		6	44263

Key:

P Performance line
Industrial Grade

V Value line
Professional Grade

• Non-stock product, contact Customer Service for lead times and minimum order quantities.

PAINT ROLLERS AND ACCESSORIES

Paint Rollers can be used almost anywhere including walls, ceilings, floors, decks, fences, metal surfaces, concrete, and brick walls. Weiler carries a wide variety of rollers for the professional painter, industrial use and those weekend DIY projects.

PAINT ROLLER SELECTION GUIDE

Work Surface	Coating	Recommended Nap
Metal, Smooth Wood, Smooth Concrete	Enamels, Epoxies, Adhesives, Paint	3/16", 3/8" (Low nap)
Rough Wood, Drywall, Cement Block	All Paint	1/2", 3/4" (Medium nap)
Stucco, Brick, Concrete	All Paint	1" (High nap)



Applying primer to new drywall.

P INDUSTRIAL GRADE ROLLERS - Poly blend with PVC core.

Size	Nap	Painting Surface	Standard Pack	Item Number
3"	3/8"	Semi-smooth	24	49046
4"	3/8"	Semi-smooth	12	49044
	3/4"	Rough		49045
9"	3/16"	Smooth	12	49061
	1/2"	Semi-smooth		49062
	3/4"	Rough		49063

V VORTEC PRO® ROLLERS - Poly blend with PVC core. Reliable and efficient rollers at a value price.

Size	Nap	Painting Surface	Standard Pack	Item Number
9"	3/8"	Semi-smooth	12	49070
	1/2"	Semi-smooth		49071

P SPECIALTY ROLLERS - Can be used with all paints. Ideal for trim and touch-up.

Description	Overall Length	Std. Pack	Item No.
3" Roller with 3/8" nap. Wire frame with two tin end caps. Bent wire handle.	6-1/8"	12	49015
4" Micro Perlon Roller Reach	16-3/8"	24	49025
4" Micro Perlon Twin Pack Cover	4-1/8"	24	49066

P FRAMES - All metal with two plastic caps. Solid plastic handle with threaded grip. Can be used with threaded handle #44300.

Size	Description	Overall Length	Standard Pack	Item Number
3"	Standard-duty 1/4" dia. frame with 4 wire cage	11-3/8"	24	49019
4"	Standard-duty 1/4" dia. frame with 4 wire cage	11-3/4"	24	49018
9"	Heavy-duty 5/16" dia. frame with 5 wire cage	13-1/2"	12	49022

V VORTEC PRO FRAME - Reliable and efficient frame at a value price.

Size	Description	Overall Length	Standard Pack	Item Number
9"	Standard-duty 1/4" dia. frame with 4 wire cage	12-3/4"	24	49020

P PAINT TRAYS - A variety of trays available to meet users' specific needs.

Description	Paint Capacity	Standard Pack	Item Number
4" Plastic tray	1 Quart	24	49008
9" Galvanized steel tray; Rust resistant	2 Quart	24	49010
9" Paint tray liner	2 Quart	24	96702

V VORTEC PRO PAINT TRAY - Reliable and efficient tray at a value price.

Description	Paint Capacity	Standard Pack	Item Number
9" Economy plastic tray; Rust proof	2 Quart	20	49011



49045



49063



49070

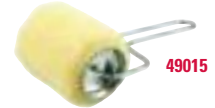

49015



49025



49018

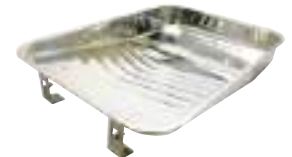

49010



49011

COATED ABRASIVES

NON-WOVEN ABRASIVES

POWER BRUSHES

NYLON BRUSHES

PACKAGED ITEMS

MAINTENANCE

ALPHABETICAL INDEX

Description	Page	Description	Page	Description	Page
4-in-1 Tube Fitting Brushes	152	Knot Wire	83-84,136,141	Interleaf Flap Wheels	56
A		Miniature	100	Internal Tube Fitting Brushes	152
Abrasive Flap Disc Technical Information	36-37	Nylon Abrasive Filament (Nylox)	121	J	
Abrasive Flap Discs	38-43,138	Stem-Mounted	85,136	Joint/Crack Cleaning Brushes	69
Tiger® X	38,138	Cutting Wheels	14-17	K	
Tiger	38,41,138	Cup Wheels	22,26	Knot Wire	
Big Cat®	40,138	D		Wheels	67-73,135,140
Tiger Angled	42	Deck Scrub Brushes	144	Cup Brushes	83-84,136,141
BobCat®	43	Deck Mops	146	End Brushes	86,136,141
Tiger Paw®	39-40,138	Diamond Filament Wheels	131	L	
Wolverine®	39-40	Disc Brushes	124-125	Lacquering Brushes	156
Abrasives	10-56	Dope Brushes	156	M	
Abrasive Nylon Filament Brushes (Nylox)	106-133	Drive Arbors	51,79,119,133	Maintenance Products	134-160
Acid Brushes	147,156	Driveway Coaters	147	Maintenance Technical Information	135-136,154
Adapters		Dually® Weld Cleaning Brushes	73	Mandrels	21,49
Metal	51,76,82,133	Dust Pans	142	Marking Brushes	156
Mounting Flange	22,26	Dusting Brushes	146	Masonry Brushes	147
Plastic Adapters	21,69,79,119,133	E		Mech Notching Wheels	21
Pressboard Adapters	133	Encapsulated Brushes (Polyflex)		Metal Adapters	49,76,133
Threaded	71,150	Stem-Mounted Wheels (Conflex)	80	Metal Chip Brush	150
TRIM-KUT Adapters	49	Conflex Brushes	80	Mill Scale Grinding Wheels	19
Adapting Nuts	21,43,46,49	Crimped Wire Wheels	73,75,77,80	Mini Disc Brushes	121,126
Angled Flap Discs	42	Cup Brushes	84	Miniature Brushes	
Arbor Hole Table	61	End Brushes	88	Cup	100
Artist Brushes	158	Flared End Brushes	89	End	101
Acid Scrub Brushes	147	Knot Wire Wheels	73	End (Nylox)	101,120
B		Small Diameter Wire Wheels	79	Wheel	100
Back-up Pads	43,46,49,54	Tube Brushes	92	Mop Handles	146
Bent Radiator Brush	155	Weld Cleaning Brushes	73	Mops	146
Bevel Brushes, Knot Wire	71	End Brushes		Mop Bucket	146
Big Cat® High Density Flap Discs	40,138	Circular Flared	89,136	Mounted Points	31
Bi-Level Scrubs	144	Controlled Flare	88	N	
Blending Discs	48-49	Crimped Wire	87-89,136,141	Nail Brushes	145
Bob Cat™ Mini Flap Discs	43	Encapsulated	88-89	New Products	7
Bob Cat Drive Mandrel	43	Knot Wire	86,137,141	Non-Sparking Brushes	102-103
Bonded Abrasives	10-31,138	Miniature	101	Non-Woven Abrasives	53-56
Bonded Abrasive Technical Information	11-13,25	Non-Sparking	103	Non-Woven Unitized Wheels	55
Bore-Rx™ Brushes	90,122	Nylon Abrasive Filament (Nylox)	101,127	Non-Woven Flap Wheels	56
Bottle Washing Brush	145	Pencil	89	Non-Woven Hand Pads	56
Bowl Brushes	145	Pilot Bonding	88	Non-Woven Strip Discs	53
Braces and Tips	140	Engineered Product (Nylox)	117	Non-Woven Surface Conditioning Discs	54
Brooms	137-141	F		Nylon Abrasive Filament Brushes (Nylox)	106-133
Burr-Rx® Brushes	119-130	File Card Brush	150	Adapters & Drive Arbors	133
Bus Brush	143	Fitch Brushes	156	Bore-Rx	122
C		Flap Wheels	50-51,56,138	Burr-Rx	119-130
Cement Finishing Brushes	147	Flaring Cup Wheels	22,26	Cup Brushes	121
Chip & Oil Brushes	155	Floor Brushes	137-139	Disc Brushes	124-125
Circular Flared End Brushes	89,136	Flue Brushes	151	Drive Arbors	133
Coated Abrasives	32-51	Flux Brushes	156	End Brushes	101,127
Coated Abrasives Technical Information	36-37	FME Area Products	132	Engineered Products	117
Combo Bucket	146	Foundry Abrasive Products	24-31	Tube Brushes	122-123
Combo Wheels	20	G		Wheel Brushes	119,128-132
Concave Brushes	81	Garage Brushes	139	Nylon Tube Brushes	94,145
Cones	22-23,28-29	Glue Brushes	156	Nylon Wheels	82
Conflex Brushes	80-81,102,140	Grinding Wheels	18-21,27	Nylox Nylon Abrasive Filament Brushes	106-133
Contractor Brooms	137	Grout Detail Brush	145	Nylox Technical Information	110-116
Controlled Flare End Brushes	88	Gun Cleaning Brushes	94		
Counter Dusters	142	H			
Crack Cleaning Brushes	69	Hand Pads	56		
Crimped Wire Wheels	74-81,102,140	Hand Scrub Brushes	144-145		
Crosshole Deburring Brushes	90,122	Handles	140		
CrossFlex™ Honing Brushes	96-98	Handle Accessories	140		
Cup Brushes		I			
Bonded Cups	22,26	Industrial Grinding Wheels	8		
Crimped Wire	85,136,141	Industrial Paint Brushes	156		
Crimped Wire-Non-Sparking	103				

ALPHABETICAL INDEX

Description	Page	Description	Page	Description	Page
O					
Ordering Information	4	Circular Flared	89,136	Value Added Programs	3
P		Concave	81	Valve Guide Brushes	94
Paint Brushes	154-156	Conflex Brushes	80-81,102,140	Varnish Brushes	154-155
Paint Brush Technical Information	153	Controlled Flare	88	Vat Brush	145
Paint Rollers and Frames	157	Crimped Wire Cup	85,136	Vehicle Care Brushes	143
Parts Cleaning Brushes	154	Crimped Wire End	87-89,136,141	Vehicle Wash Brushes	143
Pencil End Brushes	89	CrossFlex Honing Brushes	96-98		
Percolator Brushes	145	Encapsulated	88-89	W	
Perma-Sweep Floor Brushes	137	Knot Wire End	86,137,141	WCP Program	3,47
Pilot Bonding Brushes	88	Knot Wire Wheels	71	WPS Program	3,99
Pipeline Wheels	21	Miniature	100-101	Wall Dusting Brush	146
Plastic Adapters	19,69,79,119,133	Nylon Abrasive Filament (Nylox)	101,127	Watercolor Brushes	156
Plater's Brushes	149	Pencil End	89	Weld Cleaning Brushes	72-73
Plater's Brass Wire Wheels	76	Pilot Bonding	88	Wheel Brushes	
Plugs	23,28-29	Stencil Brushes	156	Abrasive Flap	50-51,55,138
Power Brushes	57-105	Street Brooms	139	Crimped Wire-Bench Grinder	75
Power Brush Technical Information	60-66	Stringer Bead Brushes	72-73,135,140	Crimped Wire-Encapsulated	73,75-77,79-80
Precision Express	7	Strip Discs	53	Crimped Wire-Medium Face	76
Pressboard Adapters	133	Surface Conditioning Discs	54	Crimped Wire-Non-Sparking	102
Pro-Flex™ Sweeps	137			Crimped Wire-Wide Face	77
Push Brooms	137-139	T		Knot Wire-Bevel Brushes	71
Push Broom Handles	140	Tampico Wheels	82	Knot Wire-Cable Twist	69-70,135,140
R		Technical Information		Knot Wire-Encapsulated	73
Radiator Brush	146,155	Abrasive Flap Discs	36-37	Knot Wire-Non-Sparking	102
Resin Fiber Discs	44-47	Bonded Abrasives	11-13	Knot Wire-Standard Twist	67-68,135,140
Roof Brushes	147	Maintenance Products	135-136	Knot Wire-Stringer Bead Twist	72-73,135,140
Roughneck® Weld Cleaning Brushes	72,135,140	Non-Woven Abrasives	52	Miniature	100
S		Nylon Abrasive Filament Brushes (Nylox)	110-116	Nylon	82
Safety Information	5	Paint & Varnish	154	Nylon Abrasive Filament (Nylox)	119,128-132
Sash Brushes	154	Power Brushes	60-66	Plater's	76
Scratch Brushes	148-150	Tiger® Abrasive Flap Discs	38-43,138	Small Diameter (Copper Center)	78-79
Scrub Brushes	144-145	Tiger Angled Flap Discs	42	Stem-Mounted	80-81,135,140
Selection Guides		Tiger Big Cat® Flap Discs	40,138	Tampico	82
Abrasive Flap Discs	36-37	Tiger BobCat™ Flap Discs	43	Whisk Brooms	141
Bonded Abrasives	12-13,25	Tiger Paw™ Abrasive Flap Discs	39-40,138	Whitewash Brush	147
Power Brushes	60	Tiger Trim Flap Discs	42	Wide Face Brushes	104-105
Cup Brush Size Selection	83	Tiger X Flap Discs	38	Wire Brooms	139
Resin Fiber Discs	44	Tiger Flap Wheels	50	Wire Duster	150
Tube Brushes	91	Tire Cleaning Brush	143	Wire Stripping Brushes	79
Maintenance Products	135-136,154,160	TRIM-KUT Discs	49	Wolverine®	
Shell Mill Holder Disc Brushes	124	Troubleshooting Guides		Cutting Wheels	15-17
Small Diameter Wire Brushes	78-79	Power Brushes	66	Grinding Wheels	19
Small Diameter Cutting Wheels	16	Nylox	118	Snagging Wheels	16
Snagging Wheels	16,30	Tube Brushes		Combo Wheels	20
Solutions Showcases		Non-Sparking	103	Flap Discs	39-40
Bonded Abrasives	11	Nylon	94,157	Flap Wheels	51,138
Coated Abrasives	34-35	Nylon Abrasive Filament (Nylox)	122-123	Knot Wire Wheels	67,70,73
Nylox® Brushes	108-109	Wire	91-94,137	Crimped Wire Wheels	75-77,80-81
Power Brushes	58-59	Tube Fitting Brushes	152	Wire Cup Brushes	85-86
Spanner Wrench	21,43,47	Turbo Tube Brushing Tool	152	Wire End Brushes	86-87
Special Brush Designs	95				
Spoke Brush	143	U			
S.P.O.T. Safety Training	3	UltraCut 1mm Thin Cutting Wheels	14		
Squeegees	142	Unitized Wheels	55		
Stem-Mounted Brushes		Upholstery/Spotting Brush	143		
		Upright Brooms	141		
		Utility Brushes	144-145		
		Utility Scrub Brushes	144-145		
		V			

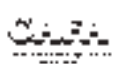

ITEM NUMBER INDEX

Item No.	Page	Item No.	Page	Item No.	Page	Item No.	Page	Item No.	Page	Item No.	Page	Item No.	Page
00104	74	03809	76,82,133	08375	67	10057	88	12276	83	13266	70	16933	78
00105	74	03810	76,82,133	08395	67	10058	88	12301	84	13276	70	16943	78
00114	74	03811	76,82,133	08534	69	10059	88	12306	83	13281	83	16963	78
00134	74	03812	76,82,133	08565	69	10067	103	12316	83	13282	83	16973	78
00135	74	03813	76,82,133	08615	69	10073	89	12326	83	13283	83	17202	90
00144	74	03814	76,82,133	08695	69	10076	89	12356	83	13284	83	17206	122
00154	74	03824	76,82,133	08750	72	10091	103	12376	83	13285	83	17207	90
00156	80	03835	51	08756	72	10099	89	12396	83	13286	83	17208	122
00184	74	03910	133	08766	72	10128	103	12406	83	13299	102	17209	90
00204	74	03913	133	08775	72	10134	89	12416	83	13406	71	17210	122
00214	74	03915	133	08776	72	10141	86	12456	83	13416	71	17211	90
00234	74	03944	133	08786	72	10142	86	12476	83	13423	71	17212	122
00264	74	03991	90,122	08796	72	10150	89	12536	84	13426	71	17214	90
00274	74	03993	90,122	08806	72	10151	89	12556	84	13436	71	17215	122
01035	74	04400	79,119,133	08835	67	10152	120,127	12576	84	13456	71	17216	90
01045	74	04401	79,119,133	08878	69	10153	120,127	12636	84	13466	71	17218	90
01049	74	04402	79,119,133	08879	69	10154	120,127	12676	84	13476	71	17223	82
01055	74	04455	21,69	08916	72	10155	120,127	12686	84	13486	71	17233	82
01065	74	06020	76	08926	72	10156	120,127	12726	84	13711	83	17263	82
01068	74	06040	76	08954	72	10157	120,127	12736	83	13712	83	17453	82
01075	74	06050	76	08975	67	10158	103	12746	83	13717	83	17532	119
01085	75	06060	76	09000	72	10187	86	12756	84	13718	83	17533	119
01095	75	06070	76	09100	72	10188	87	12766	84	14016	85	17535	119
01115	75	06080	76	09104	68	10208	86	12776	102	14026	85	17541	119
01125	75	06090	76	09134	68	10210	86	12796	84	14036	85	17543	119
01135	74	06100	76	09160	68	10211	86	12826	83	14066	85	17548	119
01138	74	06110	76	09180	68	10212	86	12816	83	14076	85	17555	119
01145	74	06120	76	09200	72	10213	86	12846	83	14126	85	17563	119
01148	74	06150	76	09379	69	10215	86	12856	83	14166	85	17565	119
01155	74	06160	76	09400	72	10216	86	12866	83	14206	85	17567	119
01158	74	06170	76	09410	68	10217	86	12886	83	14216	85	17568	119
01165	74	06180	76	09430	68	10218	86	12906	84	14256	85	17600	81
01168	74	06190	76	09440	68	10220	86	12916	84	14300	85	17601	81
01175	74	06200	76	09460	68	10301	88	12926	84	14301	85	17602	81
01178	74	06440	76	09480	68	10302	88	13300	84	14302	85	17603	81
01179	74	06450	76	09490	68	10303	88	13301	84	14303	85	17604	81
01228	74	06490	76	09500	72	10305	88	13302	84	14304	85	17605	81
01238	74	06530	76	09510	68	10306	88	13009	83	14306	85	17608	81
01248	74	06620	76	09530	68	10307	88	13015	83	14310	103	17609	80
01250-12	74	06645	77	09540	68	10309	88	13016	83	14311	103	17610	80
01258	74	06655	77	09719	67	10310	88	13020	83	14313	85	17611	80
01259	74	07700	133	09790	68	10311	88	13021	83	14314	103	17612	80
01299	74	07701	133	09840	68	10313	88	13025	83	14315	85	17614	80
01309	74	07702	133	09856	72	10314	88	13077	80	14316	103	17615	80
01319	74	07715	133	09866	72	10315	88	13078	80	14317	85	17616	80
01320-14	74	07721	79,119	09870	67	10317	88	13081	80	14318	85	17617	80
01329	74	07722	79	09990	68	10319	88	13085	80	14320	85	17618	80
01339	74	07723	79,119	10001	87	10321	88	13103	70	14321	85	17619	81
01349	74	07724	79,119	10002	87	10322	88	13105	70	14401	121	17620	81
01415	102	07725	79,119	10003	87	10323	88	13106	70	14403	121	17621	81
01475	102	07726	79	10004	87	10371	87	13108	70	14404	121	17622	81
01502	75	07727	79	10005	87	10374	87	13110	70	14413	121	17623	81
01505	75	07729	79,119	10006	87	10377	87	13113	70	14414	121	17629	119
01506	75	07746	71	10007	87	10378	87	13117	70	14506	121	17633	119
01508	75	07756	51	10008	87	10379	87	13120	70	14516	121	17637	81
01509	75	07761	55	10009	87	10380	87	13121	102	14576	121	17641	102
01511	75	07764	55	10010	87	10381	87	13124	72	14606	103	17680	71
01514	75	07766	43	10011	87	10387	86	13125	72	14616	103	17681	71
01515	75	07769	71	10012	87	10388	86	13127	72	15071	78	17682	71
01675	74	07772	71	10013	87	10392	86	13128	72	15101	78	17684	71
01695	74	08004	67	10014	87	10393	86	13130	72	15111	78	17686	71
01705	74	08014	67	10015	87	11000	87	13131	72	15131	78	17687	71
01775	74	08024	67	10016	87	11001	87	13132	72	15141	78	17689	71
01795	74	08034	67	10017	87	11003	87	13134	72	15151	78	17691	71
01805	74	08044	67	10018	87	11004	87	13135	72	15302	78	17901	81
01809	74	08045	67	10019	87	11006	87	13138	72	15312	78	17902	81
01898	74	08064	67	10020	87	11007	87	13150	83	15322	78	17903	81
01939	74	08075	67	10021	87	11010	87	13152	83	15332	78	17906	81
01949	74	08085	67	10022	87	11011	87	13153	83	15433	78	17907	81
02325	76	08095	67	10023	87	11013	87	13155	83	15443	78	17909	81
02335	76	08105	67	10024	87	11014	87	13156	83	15463	78	17912	81
03000	77	08106	70	10025	86	11016	87	13160	83	15473	78	17914	81
03010	77	08125	67	10026	86	11017	87	13163	83	15513	78	17915	81
03020	77	08135	67	10027	86	11100	88	13177	85	15523	78	17917	81
03030	77	08138	67	10028	86	11101	88	13178	85	15533	78	17922	81
03060	77	08145	67	10029	86	11102	88	13181	85	15543	78	17923	81
03070	77	08155	67	10030	86	11103	88	13182	85	15553	78	17930	81
03090	77	08178	67	10031	86	11105	88	13188	85	15563	78	17931	81
03100	77	08179	67	10032	86	11110	88	13201	70	15573	78	17933	81
03110	77	08189	67	10033	89	11112	88	13208	70	15637	78	17935	81
03140	77	08200-14	67	10034	89	11113	88	13231	103	15647	78	17936	81
03150	77	08209	67	10035	89	11114	88	13232	72	15667	78	17937	81
03160	77	08219	67	10037	89	11115	88	13234	72	15677	78	17950	81
03180	77	08254	67	10038	89	11140	86	13238	72	15732	78	17951	81
03190	77	08264	67	10039	89	11141	86	13240	85	15762	78	17952	81
03200	77	08271	102	10040	89	11142	89	13242	85	16263	119	17953	81
03210	77	08274	67	10041	89	11160	120,127	13243	85	16310	119	17954	81
03220	77	08284	67	10042	89	11161	120,127	13244	85	16315	119	17955	81
03230	77	08294	67	10043	89	11162	120,127	13245	85	16461	78	17956	81
03240	77	08309	68	10044	89	11165	120,127	13249	72	16471	78	17957	81
03403	133	08314	67	10045	89	11166	120,127	13253	83	16521	78	17958	81
03480	77	08319	68	10046	89	11169	120,127	13254	83	16712	78	17959	81
03510	77	08325	67	10047	89	11170	120,127	13255	83	16833	78	17961	81
03520	77	08339	68	10048	89	12120	84	13256	83	16843	78	17962	81
03590	77	08345	67	10050	89	12206	83	13257	83	16853	78	17963	81
03680	77	08346	70	10056	88	12256	83	13258	83	16873	78	17964	81

ITEM NUMBER INDEX

Item No.	Page	Item No.	Page	Item No.	Page	Item No.	Page	Item No.	Page	Item No.	Page		
17965	81	21122	91	25251	142	30738	51	34159	97	36218	73	40163	155
17966	81	21124	91	25252	142	30745	51	34160	97	36219	73	40164	155
17967	81	21125	91	26000	100	30746	51	34161	97	36224	70	40165	155
17968	81	21126	123	26001	100	31084	130	34162	97	36225	73	40166	155
17969	81	21128	123	26003	100	31094	130	34175	97	36227	67	41000	156
17971	81	21130	123	26004	100	31102	130	34176	97	36230	85	41001	156
17972	81	21132	123	26005	100	31103	130	34181	97	36231	85	41002	156
17973	81	21133	123	26012	100	31104	130	34182	97	36236	85	41003	156
17974	81	21134	123	26014	100	31105	130	34183	97	36237	85	41004	156
17975	81	21136	123	26015	100	31110	130	34190	97	36238	84	41005	156
17976	81	21138	123	26016	100	31112	132	34191	97	36239	84	41007	156
17977	81	21139	103	26017	100	31114	130	34192	97	36244	84	41008	156
17978	81	21142	92	26021	100	31121	130	34198	97	36245	84	41009	156
17979	81	21143	92	26041	100	31122	130	34199	97	36246	87	41010	156
17981	81	21144	92	26042	100	31123	130	34200	97	36247	87	41011	156
17982	81	21148	92	26043	100	31124	130	34201	97	36248	87	41012	156
20180	82	21149	92	26059	100	31134	130	34222	97	36249	87	41013	156
20190	82	21150	92	26071	100	31135	130	34223	97	36250	86	41018	156
20490	82	21152	103	26072	100	31136	130	34238	97	36251	86	41019	156
20600	129	21161	93	26074	100	31240	130	34257	97	36255	70	41020	156
20610	129	21162	93	26075	100	31241	130	34258	98	36259	81	41021	156
20620	129	21164	91	26076	100	31255	130	34260	98	36262	75	41023	156
20630	129	21165	103	26091	100	31265	130	34262	98	36279	67	41024	156
20650	129	21167	91	26093	100	31270	130	34264	98	36282	87	42001	138
21000	93	21175	92	26095	100	31275	130	34265	98	36283	87	42002	138
21001	93	21178	103	26096	100	31280	130	34266	98	36284	87	42006	138
21004	93	21179	103	26098	101	31285	130	34267	98	36285	87	42007	138
21005	93	21181	92	26097	101	31290	130	34268	98	36286	86	42008	138
21008	93	21184	91	26099	101	31337	39	34269	98	36287	86	42013	138
21009	93	21182	103	26101	101	31338	39	34270	98	36288	86	42014	138
21015	93	21191	103	26106	101	31339	39	34272	98	36289	86	42016	138
21021	93	21203	92	26107	101	31343	39	34273	98	36290	67	42017	138
21023	93	21218	103	26108	101	31344	39	34274	98	36293	67	42021	139
21025	93	21219	103	26113	101	31345	39	34275	98	36295	73	42022	139
21027	93	21221	103	26114	101	31346	39	34276	98	36296	73	42023	139
21028	93	21232	91	26115	101	31347	39	34277	98	36297	73	42025	139
21031	93	21233	93	26116	101	31349	39	34278	98	36303	152	42026	139
21034	93	21236	91	26119	101	31350	39	34279	98	36304	152	42030	139
21035	93	21240	92	26122	101	31351	39	34280	98	36305	152	42032	139
21040	93	21245	91	26121	101	31352	39	34281	98	36307	73	42033	139
21041	93	21246	93	26128	101	31353	39	34282	98	36666	146	42035	138
21050	93	21247	91	26131	101	31355	39	34283	98	40000	154	42037	138
21051	93	21249	93	26133	101	31356	39	34284	98	40001	154	42041	138
21053	93	21252	91	26136	101,120,127	31357	39	34285	98	40002	154	42042	138
21055	93	21264	92	26138	101,120,127	31358	39	34286	98	40004	154	42047	138
21056	93	21265	92	26143	100	31361	39	34287	98	40008	154	42049	138
21058	93	21266	92	26144	100	31362	39	34288	98	40010	154	42054	139
21072	92	21267	92	26146	101,120,127	31363	39	34289	98	40020	154	42055	139
21073	92	21269	92	26155	100	31364	39	34290	98	40021	154	42095	138
21074	92	21270	103	26296	100	31367	39	34292	98	40026	155	42098	138
21075	92	21282	92	26294	100	31368	39	34293	98	40027	155	42099	139
21076	92	21304	123	26900	123	31369	39	34294	98	40028	155	42114	138
21077	92	21305	123	26901	123	31370	39	34295	98	40029	155	42134	138
21078	92	21306	123	26902	123	31387	40	34296	98	40031	155	42135	138
21079	92	21308	123	26903	123	31388	40	34314	97	40032	155	42138	139
21080	92	21309	123	26904	123	31389	40	35070	79	40035	154	42149	139
21081	92	21322	92	26905	123	31390	40	35105	75	40036	154	42163	137
21082	92	21325	123	26906	123	31391	40	35135	75	40040	154	42164	137
21083	92	21326	123	26907	123	31392	40	35160	77	40041	154	42165	137
21084	92	21327	123	26908	123	31401	39	35186	84	40056	154	42166	137
21085	92	21328	123	26909	123	31402	39	35206	73	40058	154	42167	137
21086	92	21330	123	26910	123	31403	39	35216	73	40059	154	42168	137
21087	92	21332	103	26911	123	31404	39	35222	89	40060	154	42173	139
21088	92	21340	92	26912	123	31407	39	35223	89	40074	155	42174	139
21089	92	21342	91	26913	123	31408	39	35224	89	40077	156	42210	143
21090	93	21345	123	26914	123	31409	39	35226	89	40078	156	42213	142
21091	93	21404	92	29059	102	31410	39	35233	89	40080	156	42383	140
21092	93	21413	91	29070	82	31415	39	35234	89	40082	156	44001	145
21093	93	21414	93	29078	102	31419	39	35240	79	40089	155	44003	142
21094	93	21473	123	29086	102	31420	39	35250	79	40103	155	44004	142
21095	93	21758	123	29123	119	31421	39	35260	79	40104	155	44007	141
21096	93	21759	123	29178	102	31422	39	35305	80	40106	154	44008	141
21097	93	21761	123	29356	119	31439	40	35310	80	40107	155	44009	141
21098	93	21762	123	30711	51	31452	39	35315	80	40109	155	44011	147
21099	93	21763	123	30712	51	31453	39	35340	88	40110	155	44013	144
21100	93	21764	123	30713	51	34107	97	35345	88	40111	155	44014	144
21101	93	21765	123	30715	51	34111	97	35350	88	40116	154	44016	144
21103	93	21976	123	30716	51	34123	97	35406	84	40118	154	44017	144
21104	93	22061	76	30717	51	34126	97	35416	80	40119	154	44018	140
21105	93	25100	148	30719	51	34127	97	35500	88	40120	154	44019	140
21106	91	25104	148	30720	51	34130	97	35540	88	40121	154	44020	140
21107	91	25150	148	30721	51	34131	97	35600	73	40137	155	44021	140
21108	91	25154	148	30722	51	34135	97	35800	73	40139	155	44023	144
21109	91	25201	148	30723	51	34136	97	35821	92	40140	155	44024	144
21110	91	25202	148	30724	51	34137	97	35822	92	40141	155	44025	144
21111	91	25211	149	30725	51	34139	97	35823	92	40177	155	44026	144
21112	91	25221	154	30726	51	34141	97	35825	92	40179	155	44027	144
21113	91	25222	154	30727	51	34143	97	36201	75	40180	155	44028	144
21114	91	25231	138	30728	51	34146	97	36203	76	40181	155	44031	147
21115	91	25232	138	30732	51	34148	97	36205	75	40182	155	44032	147
21116	91	25234	138	30771	51	34149	97	36207	80	40183	155	44034	147
21117	91	25235	138	30772	51	34150	97	36208	81	40184	155	44035	151
21118	91	25238	139	30729	51	34152	97	36209	81	40185	155	44036	151
21119	91	25239	139	30735	51	34153	97	36211	81	40160	155	44037	151
21120	91	25241	139	30736	51	34156	97	36212	70	40161	155	44038	151
21121	91	25242	139	30737	51	34158	97	36213	7				

ITEM NUMBER INDEX

Item No.	Page	Item No.	Page	Item No.	Page	Item No.	Page	Item No.	Page	Item No.	Page	Item No.	Page
44048	151	44432	148	50132	40	50953	43	51219	38	52621	50	57016	16
44053	148	44434	144	50133	40	50954	43	51220	38	52623	50	57020	15
44054	148	44435	140	50134	40	50956	43	51221	38	54492	55	57021	15
44055	148	44438	144	50135	40	50957	43	51222	38	54500	56	57022	15
44056	148	44448	147	50136	40	50958	43	51223	38	54501	56	57023	15
44057	148	44451	150	50139	40	50959	43	51224	38	54502	56	57030	17
44058	148	44499	140	50140	40	50960	43	51225	38	54506	56	57032	17
44061	148	44510	143	50141	40	50961	43	51226	38	54507	56	57035	17
44062	148	44548	141	50160	38	50962	43	51227	38	54508	56	57040	15
44063	148	44551	149	50162	38	50963	43	51228	38	54509	56	57041	15
44064	148	44553	137	50163	38	50964	43	51229	38	54510	56	57042	15
44065	148	44561	140	50164	38	50965	43	51231	38	55513	55	57043	15
44066	150	44562	140	50165	38	51060	40	51232	38	55541	55	57044	15
44067	150	44563	140	50166	38	51061	40	51233	38	55542	55	57045	15
44069	149	44571	140	50183	38	51062	40	51234	38	55546	55	57046	15
44074	150	44573	140	50184	38	51063	40	51237	38	56013	16	57047	15
44075	149	44574	140	50185	38	51064	40	51238	38	56015	16	57048	15
44076	149	44577	140	50186	38	51065	40	51241	38	56022	16	57049	15
44077	149	44578	140	50187	38	51066	40	51242	38	56060	16	57060	16
44078	152	44581	137	50188	38	51067	40	51250	41	56061	16	57061	15
44079	152	44584	137	50502	41	51101	39	51251	41	56062	16	57063	16
44080	152	44587	137	50503	41	51102	39	51252	41	56064	16	57064	16
44081	152	44590	137	50504	41	51104	39	51253	41	56065	16	57066	16
44082	152	44594	148	50505	41	51105	39	51254	41	56068	16	57068	16
44083	152	44600	137	50509	41	51107	39	51255	41	56070	16	57070	16
44084	152	44601	137	50510	41	51108	39	51256	41	56076	16	57071	16
44085	152	44604	137	50511	41	51109	39	51257	41	56080	16	57072	16
44086	152	44606	137	50512	41	51110	39	51300	42	56086	16	57073	16
44087	152	44609	149	50513	41	51112	39	51301	42	56099	16	57074	16
44088	156	44619	149	50514	41	51113	39	51303	42	56103	15	57075	16
44089	156	44635	140	50515	41	51114	39	51304	42	56108	15	57080	15
44090	156	44637	149	50516	41	51115	39	51305	42	56118	15	57081	15
44099	141	44660	149	50517	41	51118	39	51306	42	56128	16	57082	15
44100	148	44663	144	50518	41	51119	39	51309	42	56129	16	57083	15
44101	148	44690	152	50519	41	51120	39	51312	42	56130	16	57086	17
44103	141	44692	144	50520	41	51121	39	51313	42	56131	16	57087	17
44110	94,145	44693	144	50541	41	51123	39	51314	42	56163	16	57091	17
44111	94,145	44699	144	50542	41	51124	39	51315	42	56165	16	57090	17
44112	94,145	44731	149	50543	41	51125	39	51316	42	56166	16	57092	17
44113	94,145	44732	149	50544	41	51126	39	51317	42	56230	17	57093	17
44114	94,145	44733	149	50545	41	51129	39	51318	42	56239	17	57094	17
44115	94,145	44805	150	50592	39	51132	39	51319	42	56240	17	57097	17
44116	149	44806	150	50593	39	51133	39	51321	42	56247	17	57100	20
44117	149	44810	150	50594	39	51134	39	51322	42	56271	15	57101	20
44416	161	45500	142	50595	39	51135	39	51434	56	56273	15	57102	20
44118	149	45506	142	50601	39	51137	39	51444	56	56275	15	57103	20
44119	149	45507	142	50606	39	51139	39	51454	56	56277	15	57104	20
44418	161	45510	142	50649	39	51140	39	51456	56	56278	15	57105	20
44124	151	45511	142	50650	39	51142	39	51457	56	56279	19	57108	20
44125	151	45534	142	50651	39	51143	39	51460	56	56280	19	57109	20
44128	151	45535	142	50659	39	51145	39	51512	54	56281	15	57120	19
44131	151	45537	142	50660	39	51146	39	51513	54	56282	15	57121	19
44133	151	45538	142	50661	39	51147	39	51514	54	56283	15	57122	19
44135	151	49008	157	50694	39	51148	39	51517	54	56383	15	57123	19
44137	151	49010	157	50699	39	51149	39	51521	54	56384	15	57124	19
44139	151	49011	157	50706	39	51150	39	51522	54	56385	15	57125	19
44149	151	49015	157	50713	39	51153	39	51523	54	56391	15	57128	19
44150	151	49018	157	50714	39	51154	39	51530	54	56392	15	57129	19
44152	151	49019	157	50715	39	51155	39	51531	54	56393	15	57134	19
44154	151	49020	157	50803	40	51156	39	51532	54	56423	20	57135	19
44156	151	49022	157	50804	40	51157	39	51533	54	56424	20	57136	19
44159	151	49025	157	50805	40	51158	39	51534	54	56425	20	57137	19
44167	149	49044	157	50806	40	51160	40	51535	54	56426	20	58000	15
44169	151	49045	157	50808	40	51161	40	51551	49,54	56427	20	58001	15
44189	149	49046	157	50809	40	51162	40	51552	43,49,54	56428	20	58002	15
44213	94,145	49061	157	50810	40	51163	40	51562	54	56429	20	58003	15
44232	149	49062	157	50823	40	51164	40	51569	54	56430	20	58005	14
44235	148	49063	157	50824	40	51165	40	51575	54	56449	19	58006	14
44240	149	49066	157	50825	40	51166	40	51578	54	56454	19	58011	16
44251	149	49070	157	50843	40	51167	40	51762	53	56455	19	58012	16
44260	150	49071	157	50844	40	51168	40	51763	53	56457	19	58013	16
44261	156	50002	42	50845	40	51169	40	51764	53	56464	19	58014	16
44263	156	50003	42	50902	43	51170	40	51765	53	56466	19	58020	15
44266	141	50004	42	50903	43	51175	39	51766	53	56467	19	58021	15
44290	140	50006	42	50904	43	51176	39	51767	53	56468	19	58022	15
44299	148	50007	42	50905	43	51177	39	51768	53	56469	19	58023	15
44300	140	50008	42	50912	43	51179	39	51769	53	56470	19	58028	17
44301	140	50009	42	50913	43	51180	39	52003	50	56473	19	58029	17
44302	140	50010	42	50914	43	51181	39	52004	50	56474	15	58030	15
44303	140	50100	38	50915	43	51200	38	52005	50	56475	15	58031	15
44305	141	50101	38	50916	43	51201	38	52009	50	56476	15	58032	15
44306	140	50102	38	50923	43	51202	38	52010	50	56477	15	58033	15
44307	143	50103	38	50924	43	51203	38	52011	50	56484	21,43	58051	20
44314	145	50104	38	50925	43	51204	38	52015	50	56485	49	58050	20
44315	143	50105	38	50932	43	51205	38	52016	50	56489	21,55	58052	20
44316	94,145	50106	38	50933	43	51206	38	52017	50	56490	21	58053	20
44317	140	50107	38	50934	43	51207	38	52024	50	56491	21	58054	20
44318	143	50109	38	50935	43	51208	38	52025	50	56494	21,43	58055	20
44351	142	50112	38	50936	43	51209	38	52027	50	56495	21,43	58056	20
44354	142	50113	38	50946	43	51210	38	52028	50	56496	49	58064	20
44391	145	50117	42	50947	43	51212	38	52029	50	57001	16	58066	21
44395	144	50118	42	50948	43	51213	38	52366	50	57010	16	58068	21
44416	149	50121	42	50949	43	51214	38	52367	50	57011	16	58069	18
44418	149	50122	42	50950	43	51215	38	52601	50	57012	16	58070	18
44428	144	50130	40	50951	43	51216	38	52611	50	57014	16	58071	18
44429	144	50131	40	50952	43	51217	38	52613	50	57015	16	58072	18

ITEM NUMBER INDEX

Item No.	Page	Item No.	Page	Item No.	Page	Item No.	Page	Item No.	Page	Item No.	Page	Item No.	Page
58073	18	59493	47	60423	46	68336	31	69866	46	83110	129	86129	128
58074	18	59494	47	60508	49	68337	31	69867	46	83111	129	86130	128
58075	18	59495	47	60509	43,49	68338	31	69868	46	83130	129	86131	128
58078	18	59497	47	60550	48	68339	31	69871	46	83140	129	86132	128
58079	18	59501	47	60551	48	68340	30	69880	46	83150	129	86133	128
58081	19	59503	47	60555	48	68341	30	69881	46	83180	131	86134	128
58080	19	59505	47	60556	48	68342	30	69883	46	83190	131	86135	128
58082	19	59506	47	60570	48	68343	30	69887	46	83300	131	86136	128
58083	19	59507	47	60571	48	68344	30	69888	46	83330	131	86137	128
58086	19	59520	47	60572	48	68345	30	69890	46	83340	131	86139	128
58087	19	59521	47	60575	48	68346	30	69894	46	83350	131	86140	128
58088	19	59523	47	60576	48	68347	30	69895	46	83405	129	86142	124
58090	21	59526	47	60577	48	68348	30	69898	46	83430	131	86143	124
58092	21	59527	47	60601	46	68349	30	70208	139	83440	131	86151	122
58094	21	59528	47	60603	46	68350	22,26	70209	139	83450	131	86152	122
58095	21	59541	47	60611	46	68351	26	70210	139	83513	129	86154	122
58100	15	59547	47	60640	48	68352	22,26	70211	139	83514	129	86155	122
58101	15	59571	47	60643	48	68353	22,26	70212	139	83516	129	86156	122
58102	15	59573	47	60644	48	68354	26	70215	139	83717	129	86159	132
58103	15	59575	47	60646	48	68355	22,26	70300	141	83718	129	86165	130
58107	15	59576	47	60650	48	68356	22,26	70304	141	83750	131	86167	124
58109	15	59577	47	60653	48	68357	26	70308	141	83910	131	86181	128
58110	15	59579	47	60654	48	68358	22,26	70312	143	83940	131	86182	128
58111	15	59600	47	60656	48	68359	22,26	70324	141	83950	131	86198	124
58112	15	59601	47	60660	48	68360	26	70325	141	84730	131	86199	124
58113	15	59602	47	60663	48	68361	22,26	71019	142	84941	129	89023	133
58114	20	59603	47	60664	48	68362	22,26	71076	146	85150	131	89024	133
58115	20	59604	47	60666	48	68364	22,26	71077	142	85733	121,126	89029	133
58120	18	59605	47	60670	48	68365	23,29	71078	142	85736	121,126	89033	133
58121	18	59611	47	60673	48	68366	31	71079	142	85738	121,126	94000	68
58122	18	59701	46	60674	48	68370	27	72034	144	85750	121,126	94008	69
58123	18	59702	46	60676	48	68371	27	72058	144	85752	121,126	94012	84
58124	18	59703	46	60738	48	68372	27	72086	144	85753	121,126	94026	69
58125	18	59704	46	60741	48	68373	27	72101	144	85773	121,126	94224	69
58128	18	59705	46	60742	48	68374	27	73050	146	85776	125	95013	149
58129	18	59707	46	60744	48	68375	27	73054	22,26	85778	125	95014	149
58130	14	59711	46	60751	48	68376	19	73055	146	85786	125	95016	132
58131	14	59712	46	60754	48	68377	19	73111	147	85788	125	95028	94
58200	15	59713	46	60755	48	68378	27	73156	143	85792	125	95029	94
58201	15	59714	46	60757	48	68379	27	73180	147	85794	125	95129	94
58202	15	59731	46	60778	48	68380	27	73195	147	85798	125	95151	149
58203	15	59732	46	60781	48	68381	27	73217	148	85806	125	95202	93
58205	15	59733	46	60782	48	68382	27	73218	148	85814	125	95203	93
58206	15	59734	46	60784	48	68383	27	73233	145	85816	125	95301	94
58209	15	59735	46	60791	48	68384	27	74002	147	85818	125	95502	155
58210	15	59737	46	60794	48	68385	27	74004	147	85824	125	95567	94
58215	20	59806	49	60795	48	68386	27	74015	147	85826	125	95660	94
58216	20	59807	49	60797	48	68387	27	74020	147	85832	125	95665	94
58225	18	59811	49	60850	48	68388	27	74048	147	85842	125	95925	151
58226	18	59812	49	60855	48	68389	27	74053	147	85844	125	96702	157
58227	18	59813	49	60870	48	68390	27	75000	145	85850	125	99307	78
58228	18	59869	49	60875	48	68391	27	75060	145	85852	125	99383	149
58229	18	59871	49	60955	48	68392	27	75102	146	85854	125	99551	78
58230	18	59875	49	60975	48	68393	27	75103	146	85860	125	99553	78
58301	15	59876	49	61503	47	68400	26	75104	146	85862	125	99554	100
58303	15	59931	46	62002	47	68401	30	75105	146	85901	125	99593	143
58305	15	59932	46	62003	47	68402	30	75109	146	85908	125	99594	145
58306	15	60040	48	62004	47	68403	28	75110	146	85920	125	99714	94
58307	15	60043	48	62012	47	68404	29	75130	146	85922	125	99786	94
58308	15	60057	48	62013	47	68405	29	75131	146	85940	125	99791	94
58309	15	60059	48	62014	47	68406	29	75132	146	85948	125	99801	155
58310	15	60118	48	62015	47	68700	45	75140	146	85978	125	99805	155
58311	15	60121	48	62053	47	68701	45	75160	141	85981	121,126	99806	155
58312	15	60122	48	68069	26	68702	45	75202	142	85995	125	99823	89
58315	20	60124	48	68301	23,28	68703	45	75505	140	85996	125	99825	89
58316	20	60131	48	68303	23,28	68704	45	75525	140	85997	125		
58317	20	60134	48	68304	23,28	68705	45	75527	140	86013	121,126		
58318	20	60135	48	68305	23,28	68706	45	75528	140	86014	121,126		
58319	20	60137	48	68306	23,28	68707	45	75555	140	86097	120,127		
58320	20	60150	48	68307	23,28	68708	45	75570	145	86099	120,127		
58321	20	60152	48	68308	23,28	68709	45	77013	138	86100	120,127		
58322	20	60155	48	68309	23,28	68710	45	77014	138	86101	120,127		
58323	20	60156	48	68310	23,28	68723	45	79100	144	86102	120,127		
58324	20	60170	48	68311	23,28	68724	45	79101	144	86103	120,127		
58325	18	60171	48	68312	23,28	68725	45	79107	144	86104	120,127		
58326	18	60172	48	68313	23,28	68726	45	79109	144	86105	120,127		
58327	18	60175	48	68314	23,28	68727	45	79120	144	86106	121,126		
58328	18	60176	48	68316	23,29	68730	45	79252	147	86107	121,126		
58329	18	60338	48	68317	23,29	68731	45	79253	147	86108	121,126		
58330	18	60341	48	68318	23,29	68735	45	79800	73	86109	121,126		
58331	18	60342	48	68319	23,29	68738	45	79801	73	86110	121,126		
58332	18	60344	48	68320	23,29	68739	45	79802	73	86111	121,126		
58333	18	60351	48	68321	23,29	68741	45	79803	73	86112	124		
58334	18	60354	48	68322	23,29	68750	45	79804	73	86113	124		
58335	18	60355	48	68323	23,29	68754	45	79805	73	86114	124		
58342	16	60357	48	68324	23,29	69850	46	79810	73	86115	124		
58345	16	60382	48	68326	23,29	69851	46	79811	73	86116	124		
58348	16	60384	48	68327	23,29	69852	46	83000	129	86117	124		
59300	49	60391	48	68328	23,29	69853	46	83003	131	86120	128		
59305	49	60401	46	68329	23,29	69854	46	83004	131	86121	124		
59315	49	60403	46	68330	23,29	69857	46	83010	129	86122	124		
59326	49	60404	46	68331	23,29	69858	46	83011	129	86123	128		
59327	49	60410	46	68332	31	69859	46	83030	129	86124	128		
59403	49	60411	46	68333	31	69860	46	83040	129	86126	128		
59491	47	60414	46	68334	31	69864	46	83050	129	86127	128		
59492	47	60421	46	68335	31	69865	46	83100	129	86128	128		

THE WEILER PROMISE

At Weiler, we passionately embrace change to improve our products and our processes to move the company and our customers forward. By bringing new ideas and creative problem solving together in an open, collaborative environment, we will improve our customers' productivity and create profitable growth.



WEILER ABRASIVES GROUP

Weiler Global HQ
One Weiler Drive
Cresco, PA 18326 USA

Weiler de México
Querétaro, México

Weiler de México
Juárez, México

Weiler do Brasil
São Paulo, Brazil

Weiler EMEA HQ
Maribor, Slovenia

Zreče, Slovenia

Loče, Slovenia

Oplotnica, Slovenia

Bindlach, Germany

800.835.9999 / weilerabrasives.com



Reorder No. WC244 - Eleventh Edition / 4265PP / ©2026 Weiler Abrasives Group. All Rights Reserved.





Solutions for Cutting, Grinding, Cleaning and Finishing.