

Product and Application Information: GMR10D000

General High Voltage Evaluation User Safety Guidelines



Save all warnings and instructions for future reference.

Failure to follow warnings and instructions may result in personal injury, property damage, or death due to electrical shock and burn hazards.

The module is a Rectified AC to DC CONVERTER typically provided as an open-frame, unenclosed assembly. All testing with live AC input voltage is to be carried out **solely by qualified professional users having training, expertise, and knowledge of electrical safety & risks in development and application of high voltage electrical circuits**. If you are not suitably qualified to carry out open frame testing of this module, you should immediately stop from further work and seek support from your managers.

1. Work Area Safety (at a minimum, others may be applicable under your work safety regulations)
 1. Keep work area clean and orderly.
 2. Qualified observer(s) must be present anytime circuits are energized.
 3. Effective barriers and signage must be present in the area where the module and its interface electronics are energized, indicating operation of accessible high voltages may be present, for the purpose of protecting inadvertent access.
 4. All interface circuits, power supplies, evaluation modules, instruments, meters, scopes and other related apparatus used in a development environment exceeding 50Vrms/75VDC must be electrically located within a protected Emergency Power Off EPO protected power strip.
 5. Use stable and nonconductive work surface.
 6. Use adequately insulated clamps and wires to attach measurement probes and instruments. No freehand testing whenever possible.
2. Electrical Safety

As a precautionary measure, it is always a good engineering practice to assume that the entire Module may have fully accessible and active high voltages.

 1. De-energize the Module and all its inputs, outputs and electrical loads before performing any electrical or other diagnostic measurements. Revalidate that Module input power has been safely de-energized.
 2. With the Module de-energized, proceed with required electrical circuit configurations, wiring, measurement equipment connection, and other application needs, while still assuming the surrounding circuitry and measuring instruments are electrically live.
 3. When Setup is complete, energize the Module as intended.

WARNING: WHILE THE MODULE IS ENERGIZED, NEVER TOUCH IT OR ITS ELECTRICAL CIRCUITRY- ANY PART OF IT MAY HAVE HIGH VOLTAGES CAPABLE OF CAUSING ELECTRICAL SHOCK HAZARD.

Personal Safety

4. Wear personal protective equipment (for example, latex gloves or safety glasses with side shields) or protect the Module in an adequate lucent plastic box with interlocks to protect from accidental touch.

For more information: go to www.ganmartechologies.com. See various App Notes there.

ALL INFORMATION CONTAINED IN OR DISCLOSED BY THIS DOCUMENT IS CONSIDERED CONFIDENTIAL AND PROPRIETARY BY GANMAR TECHNOLOGIES INC. ALL DESIGN, MANUFACTURING USE, REPRODUCTION, AND SALES RIGHTS ARE EXPRESSLY RESERVED BY GANMAR TECHNOLOGIES. COMMUNICATION OF THIS INFORMATION TO OTHERS IS PROHIBITED WITHOUT PRIOR WRITTEN CONSENT BY GANMAR TECHNOLOGIES.

Product Specifications GMR10D000

Description

The GMR10D000 is a 15W module that typically requires rectified AC input and is a flyback converter with isolation.

The module uses primary side control to provide two well-regulated outputs with nominal load of up to 15W total. The main devices used in this design are wide-input range nonlinear controller with frequency adjustment and skipping cycles at low loads.

GaN device for primary switch and Schottky diode rectifiers with zero-voltage switching attain high efficiency in the smallest volume of its class.



Features

- * **Smallest off-line isolated module for effective system level integration**
- * **Easy integration into systems board for system start-up for both analog and digital multiple devices.**
- * **Allows biasing multiple HV Gallium Nitride Silicon Carbide, IGBT and MOSFETs**
- * **Does not require detailed thermal management operating at its max power and temperature.**
- * **Companion modules allow easy integration with multiple floating power returns.**

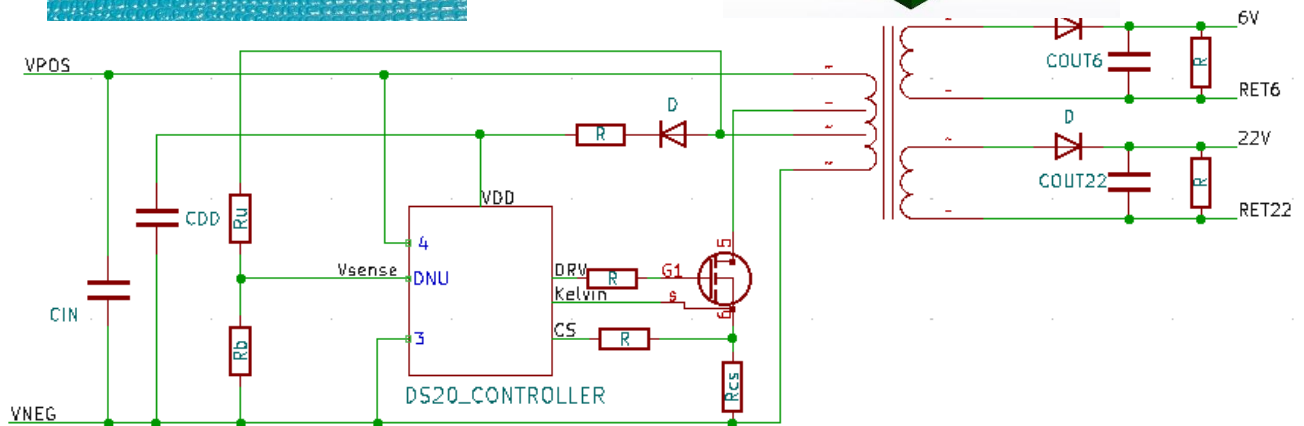
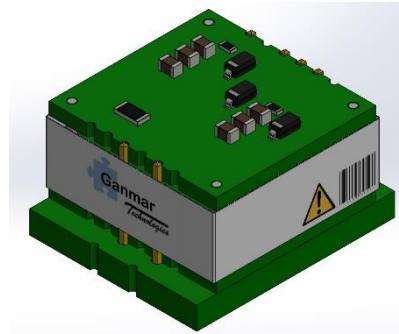

Figure 1 GMR10D000 Module Views and Schematic

For more information: go to www.ganmartechologies.com. See various App Notes there.

ALL INFORMATION CONTAINED IN OR DISCLOSED BY THIS DOCUMENT IS CONSIDERED CONFIDENTIAL AND PROPRIETARY BY GANMAR TECHNOLOGIES INC. ALL DESIGN, MANUFACTURING USE, REPRODUCTION, AND SALES RIGHTS ARE EXPRESSLY RESERVED BY GANMAR TECHNOLOGIES. COMMUNICATION OF THIS INFORMATION TO OTHERS IS PROHIBITED WITHOUT PRIOR WRITTEN CONSENT BY GANMAR TECHNOLOGIES.

Table 1 Performance and Geometrical Information

Turn-ON Delay(ms) Min/Max	Output Slew Rates 6V/22V	Load Transient Typical	Load Regulation 6V/22V	Line Regulation 6V/22V	Cross Regulation	Efficiency Total Output Power	Geom Info Pin Footprint	Output Ripple
Fig.3	Fig.3	Fig.4	Fig.5 Fig.6	Fig.5 Fig.6	Fig.7	Fig.8	Fig.1	Fig.9

1. Test Setup

1.1. Test Setup Requirements

Safety: This evaluation module is not encapsulated and there are accessible voltages that are greater than 50 V_{DC}.

WARNING
 If you are not trained in the proper safety of handling and testing power electronics, please do not test this module.
 Read this user's guide thoroughly before making test.

Voltage Source: AC Line voltage

Voltmeter: Digital voltage meter

Power Analyzer: Capable of measuring 1 mW to 200 W of input power and capable of handling 260 V input voltage. Some power analyzers may require a precision shunt resistor for measuring input current to measure input power of 5 W or less. Please read the power analyzer's user manual for proper measurement setups for full power and for stand-by power.

Oscilloscope:

- 4-Channel, 100 MHz bandwidth.
- Probes capable of handling 600 V.

Output Load: Resistive or electronic load capable of handling 15 W at 6 to 22 V.

Recommended Wire Gauge: Insulated 22 AWG to 18 AWG.

WARNING
 Caution: Do not leave Module powered when unattended

For more information: go to www.ganmartechologies.com. See various App Notes there.

ALL INFORMATION CONTAINED IN OR DISCLOSED BY THIS DOCUMENT IS CONSIDERED CONFIDENTIAL AND PROPRIETARY BY GANMAR TECHNOLOGIES INC. ALL DESIGN, MANUFACTURING USE, REPRODUCTION, AND SALES RIGHTS ARE EXPRESSLY RESERVED BY GANMAR TECHNOLOGIES. COMMUNICATION OF THIS INFORMATION TO OTHERS IS PROHIBITED WITHOUT PRIOR WRITTEN CONSENT BY GANMAR TECHNOLOGIES.

1.2. Test Setup Diagram

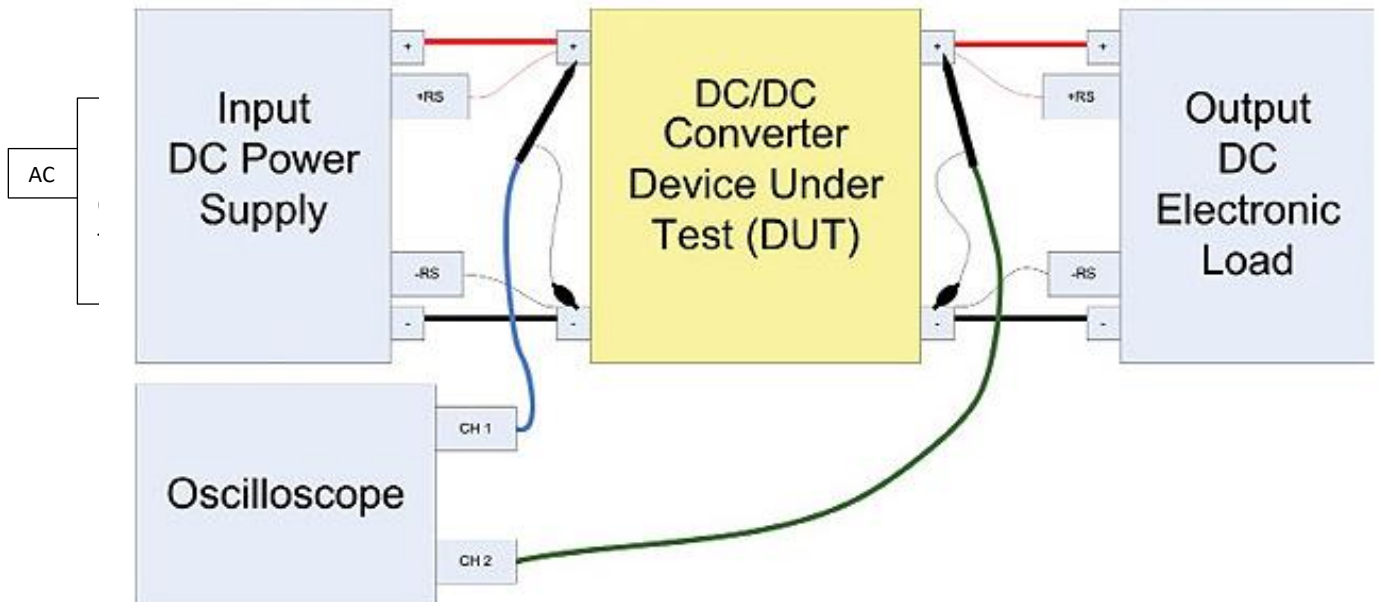

Figure 2 Module Test Setup Diagram

1.3. Eval Kit and Test Fixture

Ganmar Technologies offers an Evaluation kit with one module installed in a socket. The Evaluation board is a high-performance Test Fixture. It contains high performance EMI filter as well for full characterization of such filter Ganmar Technologies also offers for integration in customer system as needed during EMI qualification of the whole system.

1.4. AC Input Rectifier Module

There is an accompanying AC input module complete with fuse, rectifier, EMI filter with high performance common mode choke, ability to connect to a safety /shielding Earth.

For more information: go to www.ganmartechologies.com. See various App Notes there.

ALL INFORMATION CONTAINED IN OR DISCLOSED BY THIS DOCUMENT IS CONSIDERED CONFIDENTIAL AND PROPRIETARY BY GANMAR TECHNOLOGIES INC. ALL DESIGN, MANUFACTURING USE, REPRODUCTION, AND SALES RIGHTS ARE EXPRESSLY RESERVED BY GANMAR TECHNOLOGIES. COMMUNICATION OF THIS INFORMATION TO OTHERS IS PROHIBITED WITHOUT PRIOR WRITTEN CONSENT BY GANMAR TECHNOLOGIES.

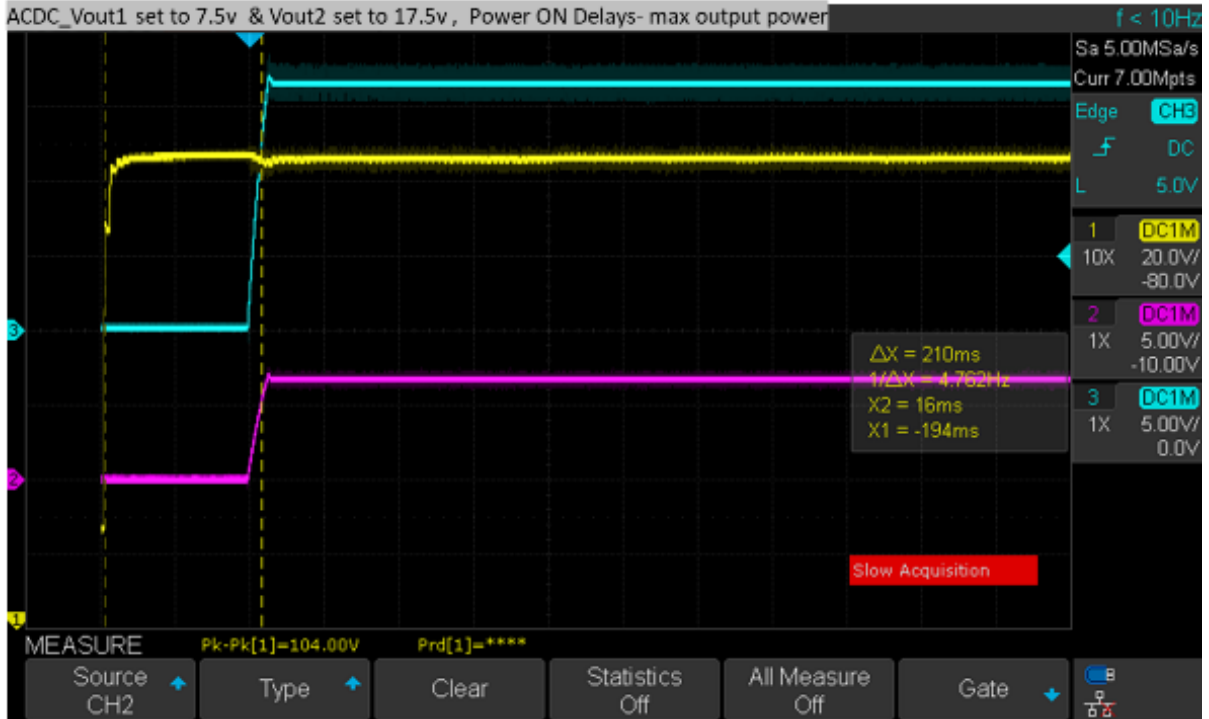

Figure 3 Reference 210 mS

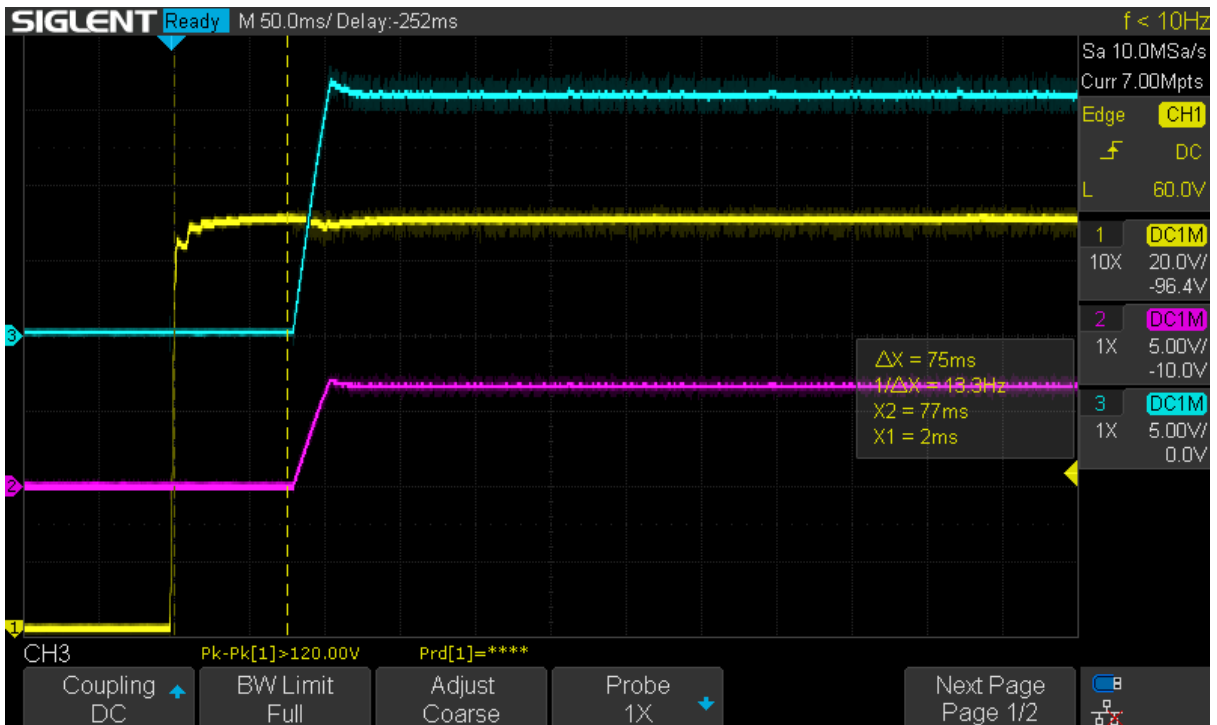

Figure 4 Turn ON Delay: Prototype Module Testing. Reference 75 mS

For more information: go to www.ganmartechologies.com. See various App Notes there.

ALL INFORMATION CONTAINED IN OR DISCLOSED BY THIS DOCUMENT IS CONSIDERED CONFIDENTIAL AND PROPRIETARY BY GANMAR TECHNOLOGIES INC. ALL DESIGN, MANUFACTURING USE, REPRODUCTION, AND SALES RIGHTS ARE EXPRESSLY RESERVED BY GANMAR TECHNOLOGIES. COMMUNICATION OF THIS INFORMATION TO OTHERS IS PROHIBITED WITHOUT PRIOR WRITTEN CONSENT BY GANMAR TECHNOLOGIES.

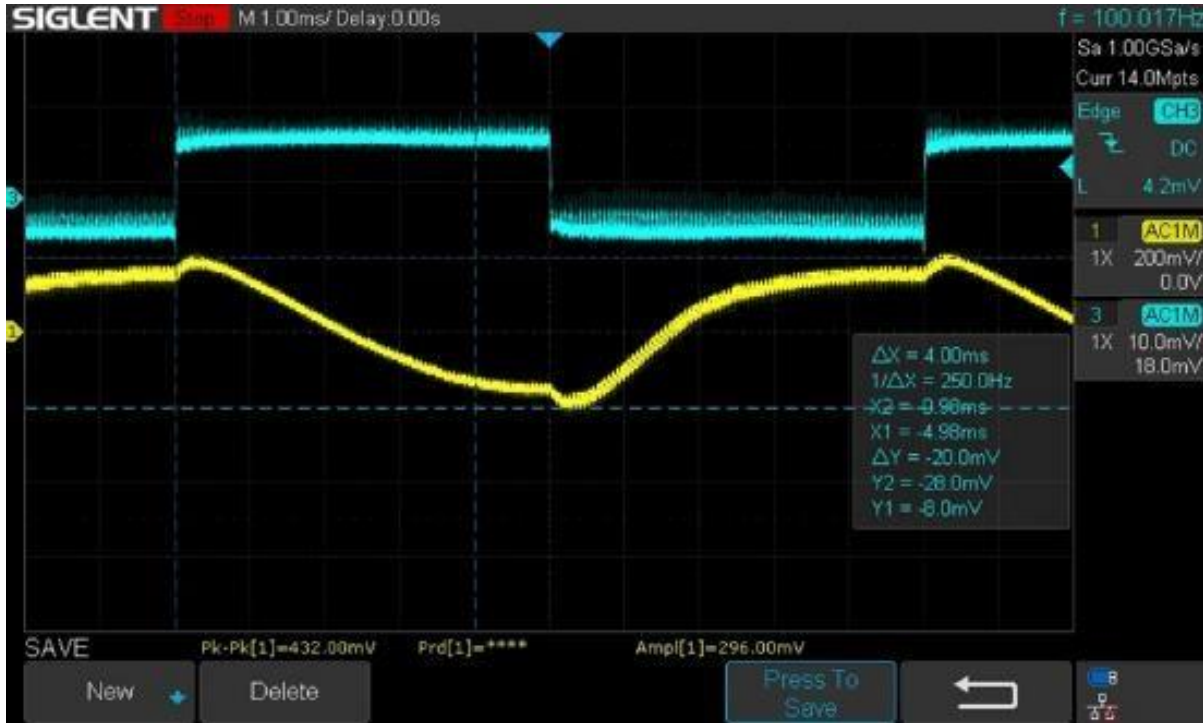

Figure 5 Typical Load Transient

For more information: go to www.ganmartechologies.com. See various App Notes there.

ALL INFORMATION CONTAINED IN OR DISCLOSED BY THIS DOCUMENT IS CONSIDERED CONFIDENTIAL AND PROPRIETARY BY GANMAR TECHNOLOGIES INC. ALL DESIGN, MANUFACTURING USE, REPRODUCTION, AND SALES RIGHTS ARE EXPRESSLY RESERVED BY GANMAR TECHNOLOGIES. COMMUNICATION OF THIS INFORMATION TO OTHERS IS PROHIBITED WITHOUT PRIOR WRITTEN CONSENT BY GANMAR TECHNOLOGIES.

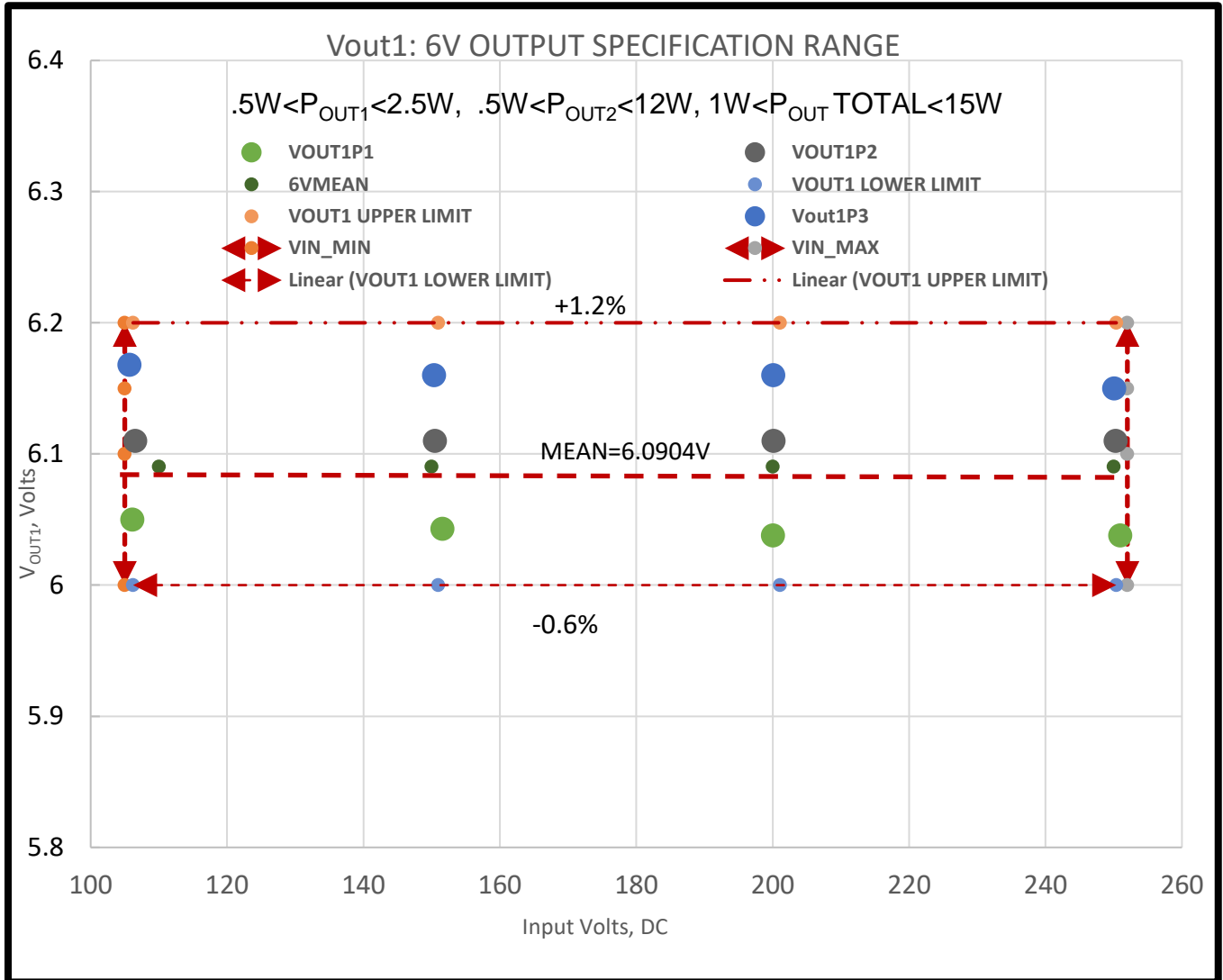

Figure 6 Load Regulation with DC Input: Showing Excellent Control

For more information: go to www.ganmartechologies.com. See various App Notes there.

ALL INFORMATION CONTAINED IN OR DISCLOSED BY THIS DOCUMENT IS CONSIDERED CONFIDENTIAL AND PROPRIETARY BY GANMAR TECHNOLOGIES INC. ALL DESIGN, MANUFACTURING USE, REPRODUCTION, AND SALES RIGHTS ARE EXPRESSLY RESERVED BY GANMAR TECHNOLOGIES. COMMUNICATION OF THIS INFORMATION TO OTHERS IS PROHIBITED WITHOUT PRIOR WRITTEN CONSENT BY GANMAR TECHNOLOGIES.

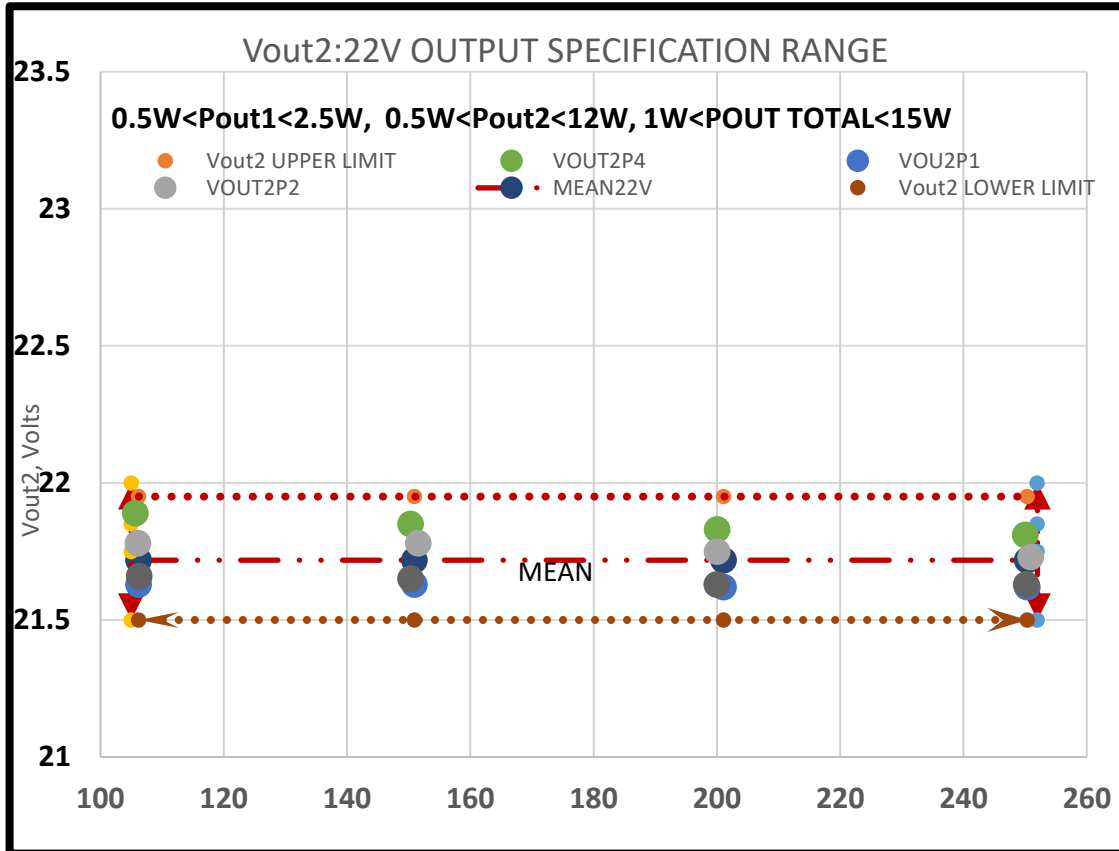

Figure 7 Load Regulation with DC Input: Showing Excellent Control 22V

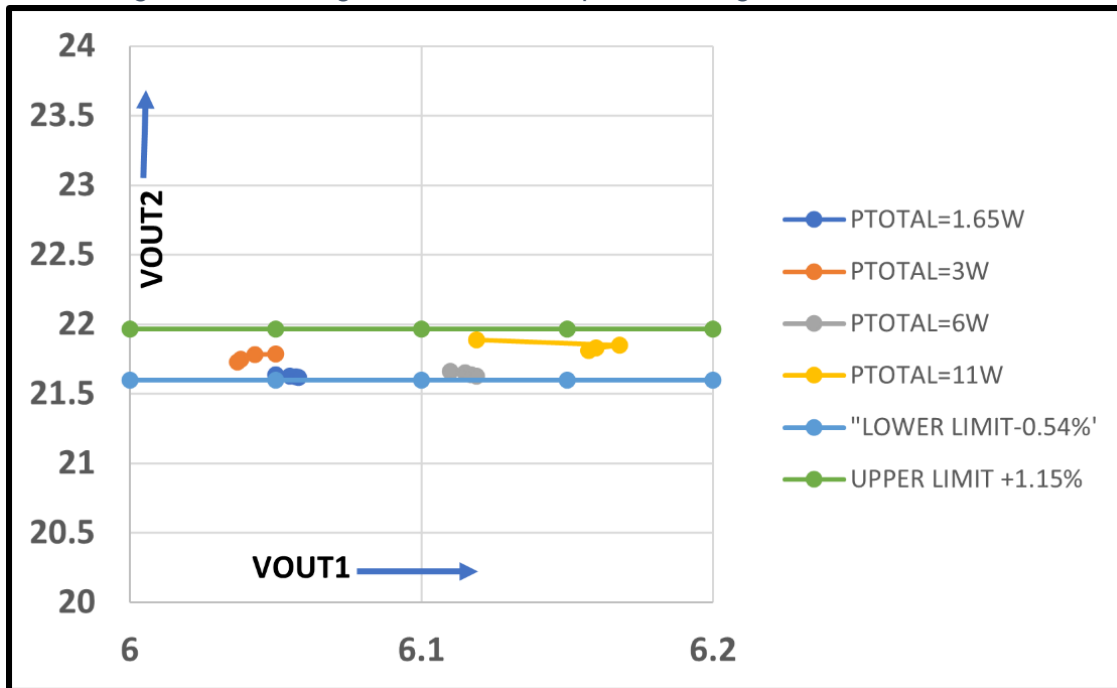

Figure 8 Cross Regulation with Total Power Output: Showing Tight Coupling

For more information: go to www.ganmartechologies.com. See various App Notes there.

ALL INFORMATION CONTAINED IN OR DISCLOSED BY THIS DOCUMENT IS CONSIDERED CONFIDENTIAL AND PROPRIETARY BY GANMAR TECHNOLOGIES INC. ALL DESIGN, MANUFACTURING USE, REPRODUCTION, AND SALES RIGHTS ARE EXPRESSLY RESERVED BY GANMAR TECHNOLOGIES. COMMUNICATION OF THIS INFORMATION TO OTHERS IS PROHIBITED WITHOUT PRIOR WRITTEN CONSENT BY GANMAR TECHNOLOGIES.

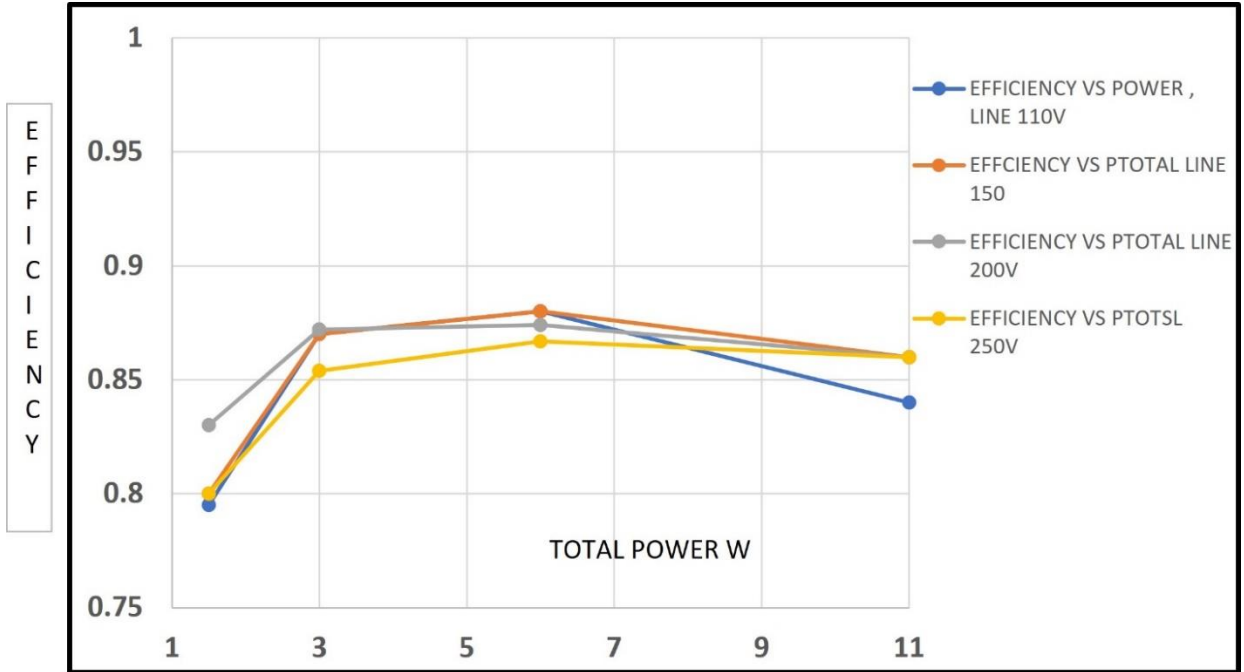

Figure 9 Efficiency with Total Power Output

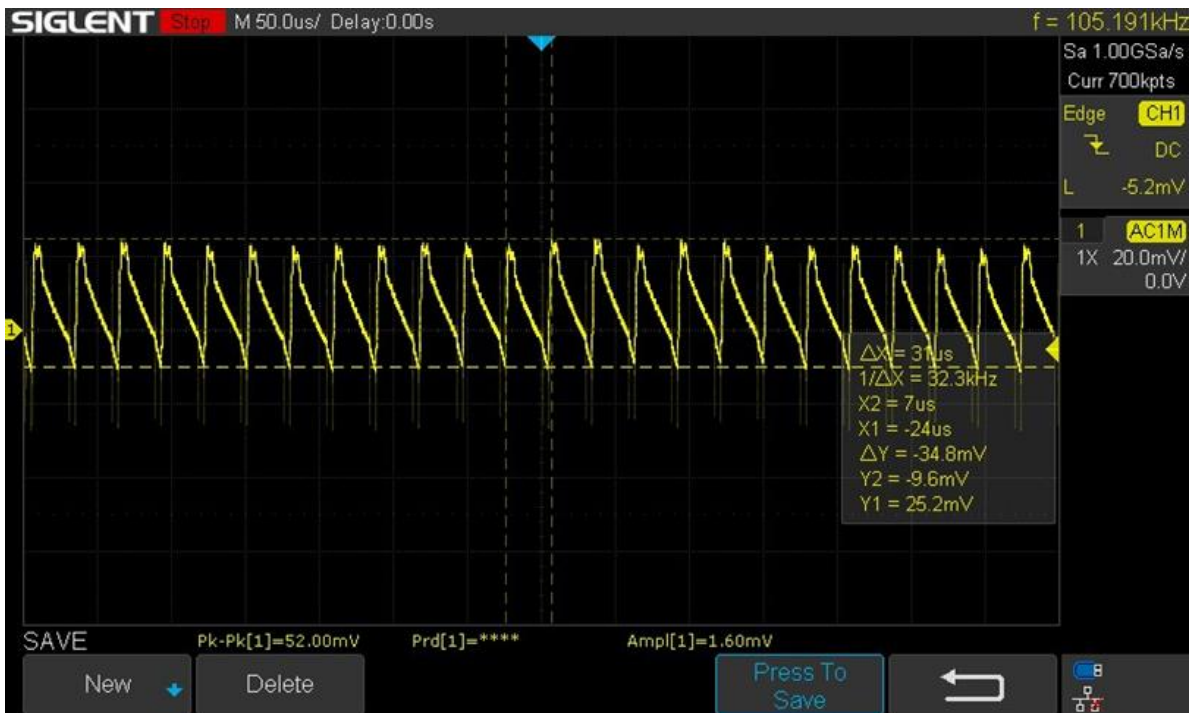

Figure 10 Ripple on Vout1 Full Load

For more information: go to www.ganmartechologies.com. See various App Notes there.

ALL INFORMATION CONTAINED IN OR DISCLOSED BY THIS DOCUMENT IS CONSIDERED CONFIDENTIAL AND PROPRIETARY BY GANMAR TECHNOLOGIES INC. ALL DESIGN, MANUFACTURING USE, REPRODUCTION, AND SALES RIGHTS ARE EXPRESSLY RESERVED BY GANMAR TECHNOLOGIES. COMMUNICATION OF THIS INFORMATION TO OTHERS IS PROHIBITED WITHOUT PRIOR WRITTEN CONSENT BY GANMAR TECHNOLOGIES.

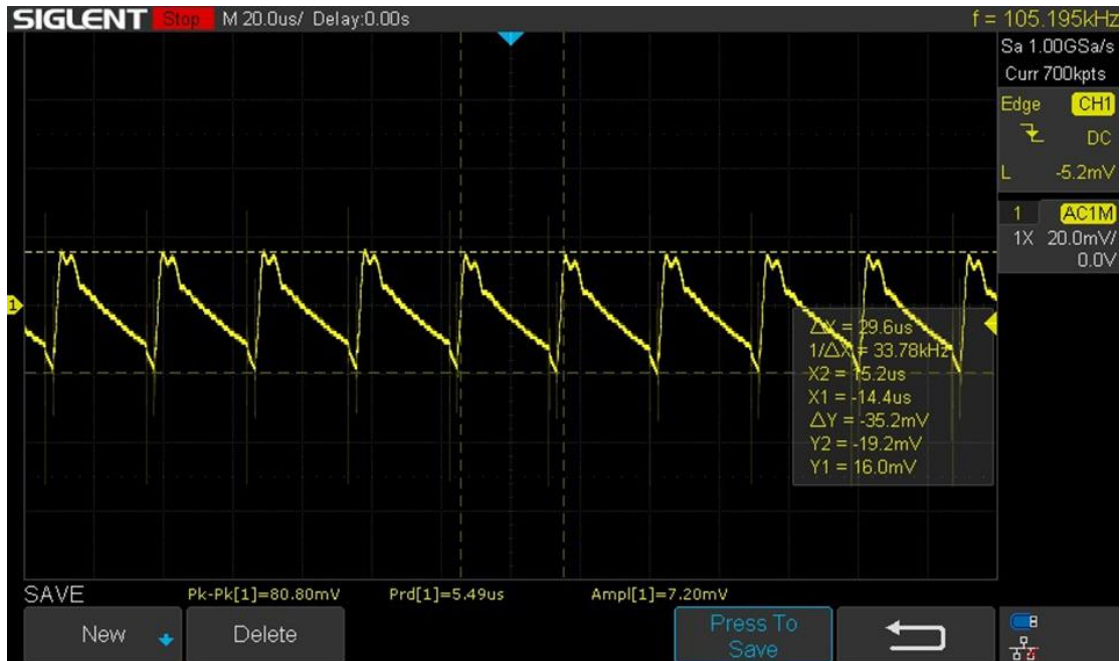

Figure 11 Ripple on V_{OUT2} Full Load

For more information: go to www.ganmartechologies.com. See various App Notes there.

ALL INFORMATION CONTAINED IN OR DISCLOSED BY THIS DOCUMENT IS CONSIDERED CONFIDENTIAL AND PROPRIETARY BY GANMAR TECHNOLOGIES INC. ALL DESIGN, MANUFACTURING USE, REPRODUCTION, AND SALES RIGHTS ARE EXPRESSLY RESERVED BY GANMAR TECHNOLOGIES. COMMUNICATION OF THIS INFORMATION TO OTHERS IS PROHIBITED WITHOUT PRIOR WRITTEN CONSENT BY GANMAR TECHNOLOGIES.

2. Mechanical

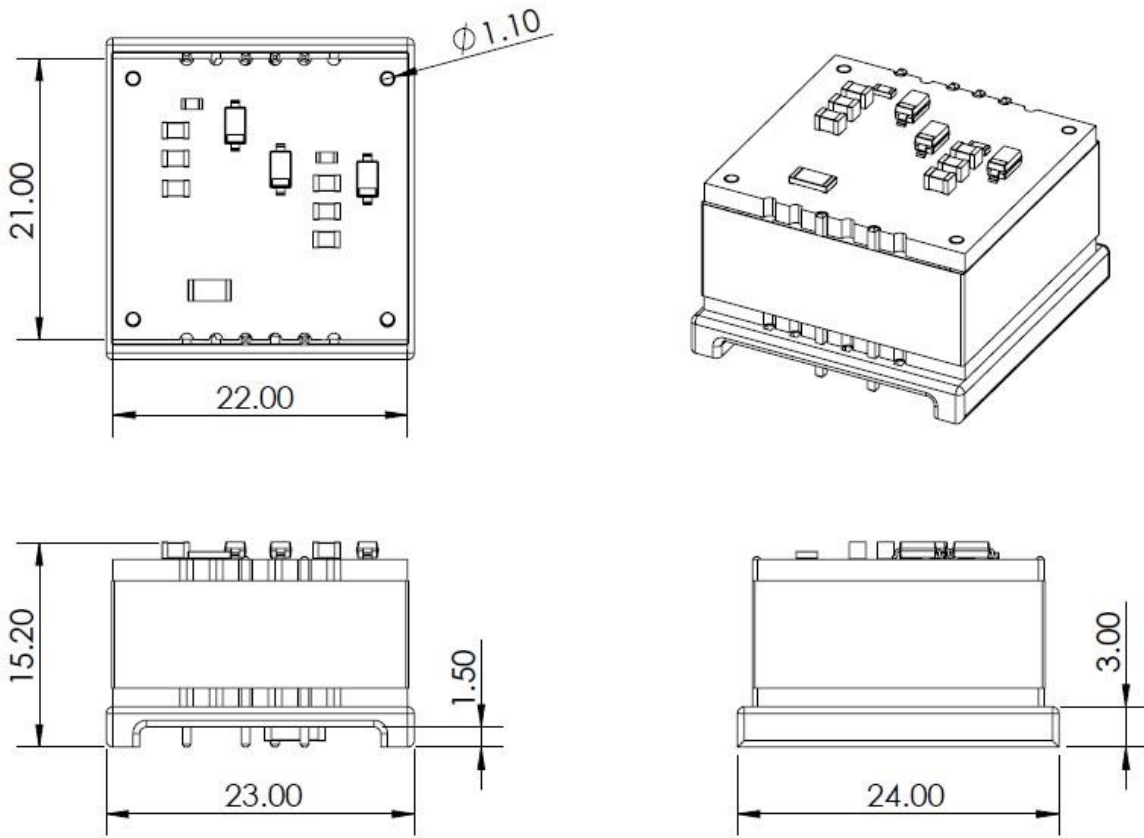

Figure 3 GMR10D000 Dimensions

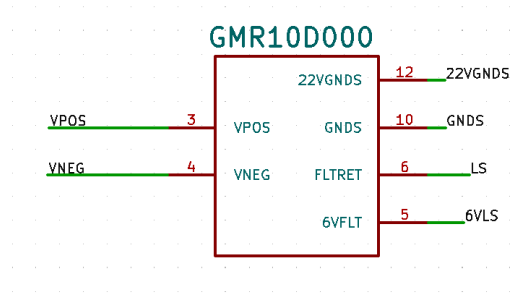

Figure 4 Pinout

For more information: go to www.ganmartechologies.com. See various App Notes there.

ALL INFORMATION CONTAINED IN OR DISCLOSED BY THIS DOCUMENT IS CONSIDERED CONFIDENTIAL AND PROPRIETARY BY GANMAR TECHNOLOGIES INC. ALL DESIGN, MANUFACTURING USE, REPRODUCTION, AND SALES RIGHTS ARE EXPRESSLY RESERVED BY GANMAR TECHNOLOGIES. COMMUNICATION OF THIS INFORMATION TO OTHERS IS PROHIBITED WITHOUT PRIOR WRITTEN CONSENT BY GANMAR TECHNOLOGIES.

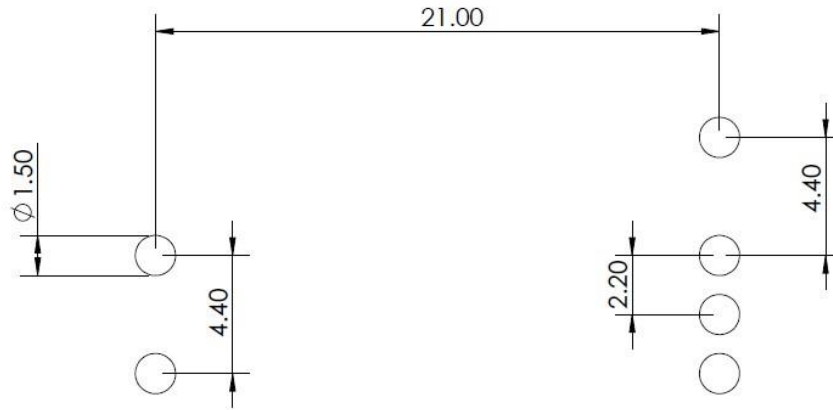

Figure 5 Through-hole Footprint

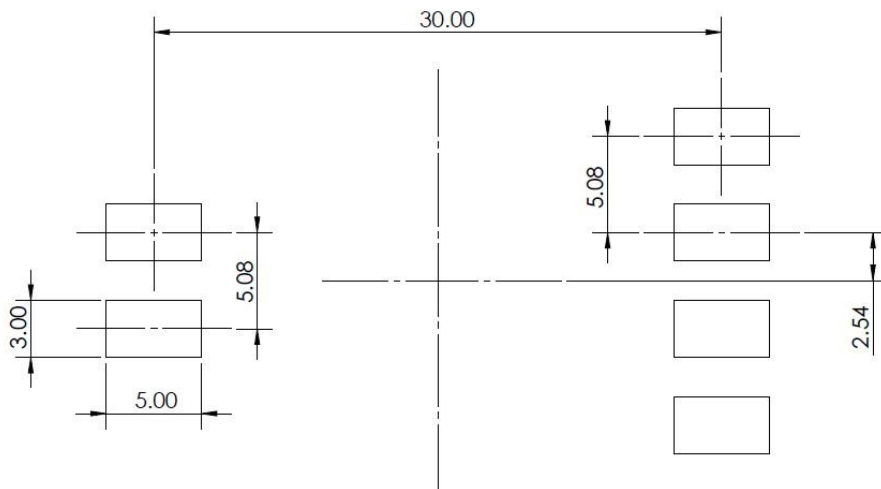

Figure 6 Surface Mount Footprint

For more information: go to www.ganmartechologies.com. See various App Notes there.

ALL INFORMATION CONTAINED IN OR DISCLOSED BY THIS DOCUMENT IS CONSIDERED CONFIDENTIAL AND PROPRIETARY BY GANMAR TECHNOLOGIES INC. ALL DESIGN, MANUFACTURING USE, REPRODUCTION, AND SALES RIGHTS ARE EXPRESSLY RESERVED BY GANMAR TECHNOLOGIES. COMMUNICATION OF THIS INFORMATION TO OTHERS IS PROHIBITED WITHOUT PRIOR WRITTEN CONSENT BY GANMAR TECHNOLOGIES.