



KEYSTONE FIGURE 990 AND 920 RESILIENT SEATED BUTTERFLY VALVES

A split body thin disc valve for high flow and modulating service
 Figure 990 - Wafer body design
 Figure 920 - Lugged body design



FEATURES

- One-piece, thin profile, disc stem provides minimum obstruction to flow, resulting in highest C_v , lowest pressure drops and best control characteristics.
- Rounded polished disc edge gives full concentric sealing, lower torques, longer seat life and tight shut-off.
- Triple function, resilient seat isolates body and stem from line media, provides drop-tight shut-off of line media at full-rated pressure and provides positive flange sealing, eliminating the need for flange gaskets.
- Heavy duty, corrosion resistant top bushing provides upper stem support, absorbs actuator sideloading and extends valve cycle life.
- Bi-directional, self-adjusting double V-cup stem seals prevent external contaminants from entering the valve.
- Split body design enables easy field replacement of seat and disc/stem and permits direct mounting of Keystone actuators without the use of couplings or brackets.

GENERAL APPLICATION

Figure 990 and 920 valves are used when modulating service or corrosion resistance is required. Heavy duty applications include food and beverage, pharmaceutical, pulp and paper, mining, oil and gas and power industries. Available with PTFE lining for light corrosive services and rubber lining for light abrasive services.

FLANGE STANDARD

Figure 990 is a resilient-seated, wafer-style, butterfly valve suitable for installation between ASME 125/150 and PN 10 and PN 16 flanges. Figure 920 provides drilled and tapped lugs around the valve body, compatible with ASME 125/150, PN 10/16 and BST'E flange standards.

TECHNICAL DATA

Sizes:	DN 25-500 (NPS 1-20) Wafer style DN 50-500 (NPS 2-20) Lugged style
Pressure ratings:	10 bar DN 25-300 (150 psi NPS 1-12) 5 bar DN 350-500 (75 psi NPS 14-20) PTFE or elastomer mold disc 7 bar DN 50-300 (100 psi NPS 2-12) 5 bar DN 350-500 (75 psi NPS 14-20)
Flange accommodation:	ASME 125/150 AS 2129 Table E PN 10/16 BST'E

⚠ WARNING

Not for end of line use.

KEYSTONE FIGURE 990 AND 920 RESILIENT SEATED BUTTERFLY VALVES

MATERIALS

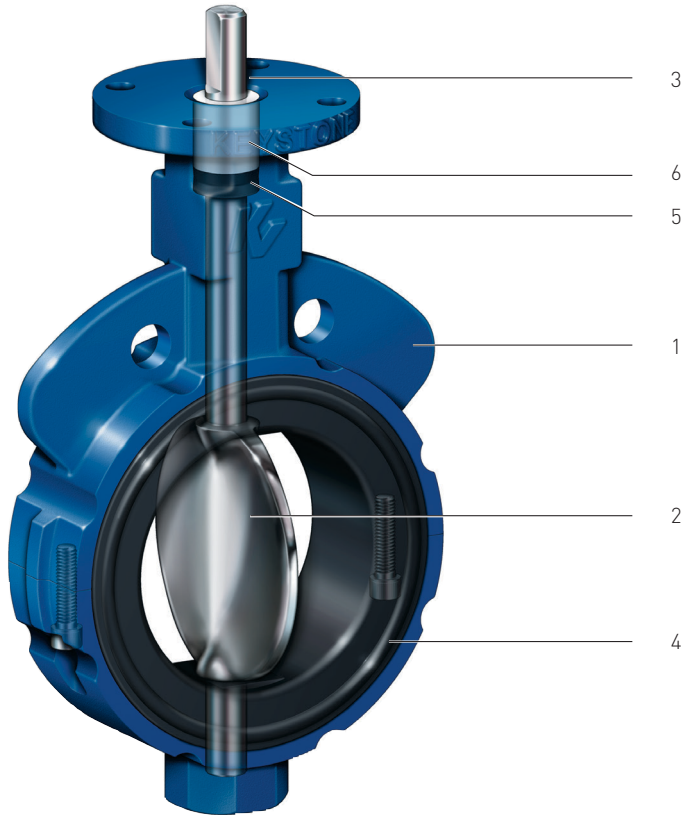

Note: Figure 990 wafer valve illustrated

LEGEND:

- A - Available
- LTD - Available in limited sizes
- ETO - Special / on request
- N - Not Available

MATERIALS

No.	Description	Material	Designation (ASTM)	Designation (EN)	Size Ranges			Regional Availability				
					DN 25-40 NPS 1-1/2	DN 50-300 NPS 2-12	DN 350-500 NPS 14-20	Americas	Europe	Asia	Pacific	
1	Two-piece body	Cast iron	ASTM A126 Class B	EN1561 GJL-250	A	A	A	A	Wafer only	A	A	
		Ductile iron	ASTM A395 Gr. 60-40-18	-	N	Lugged only		A	N	ETO	ETO	
		316 Stainless steel	ASTM A-743 CF8M	-	A	LTD	N	A	N	A	A	
2	Thin profile disc	316 Stainless steel	As Cast	ASTM A351 CF8M	EN 1.4408	A	A	A	A	A	A	A
			Brushed Finish	ASTM A351 CF8M	EN 1.4408	N	LTD	N	A	N	N	N
		316 Stainless steel	Satin Finish	ASTM A351 CF8M	EN 1.4408	A	A	ETO	A	A	A	A
			Mirror Polished	ASTM A351 CF8M	EN 1.4408	A	A	ETO	A	A	A	A
			Duplex	A890 Gr. 4A	EN 1.4470	N	LTD	N	ETO	A	ETO	ETO
		Steel PTFE molded	-	-	N	LTD	LTD	A	A	A	A	
		Steel EPDM molded	-	-	N	LTD	LTD	A	A	A	A	
		Steel NBR molded	-	-	N	LTD	LTD	A	ETO	A	A	
		Steel urethane molded	-	-	N	LTD	N	ETO	ETO	ETO	A	
		Ceramic coated	-	-	N	LTD	N	N	N	A	A	
3	Stem	316 Stainless steel	ASTM A479 S31600	EN10272 1.4401	A	A	A	A	A	A	A	
		Duplex	ASTM A479 S31803	EN10272 1.4462	Duplex, and coated disc-stems (see above)			A	A	A	A	
4	Seat	NBR (food grade)	-	-	A	A	A	A	A	A	A	
		NBR White (food grade)	-	-	N	A	LTD	A	A	A	A	
		EPDM food grade	-	-	A	A	A	A	A	A	A	
		FKM	-	-	A	A	LTD	A	A	A	A	
		PTFE-lined EPDM	-	-	N	A	A	A	A	A	A	
		PTFE-lined NBR	-	-	N	A	A	A	ETO	A	A	
		Urethane	-	-	N	LTD	N	ETO	ETO	ETO	A	
5	Stem packing	NBR	-	-	All			-	-	-	-	
6	Stem bushing	Polyester / Acetal	-	-	All bodies			-	-	-	-	
		Bronze	-	-	SS Bodies	N	N	-	-	-	-	
7	Body Screws	Stainless	18-8	A2	All			-	-	-	-	

KEYSTONE FIGURE 990 AND 920 RESILIENT SEATED BUTTERFLY VALVES

METRIC DATA

FIGURE 990 WAFER

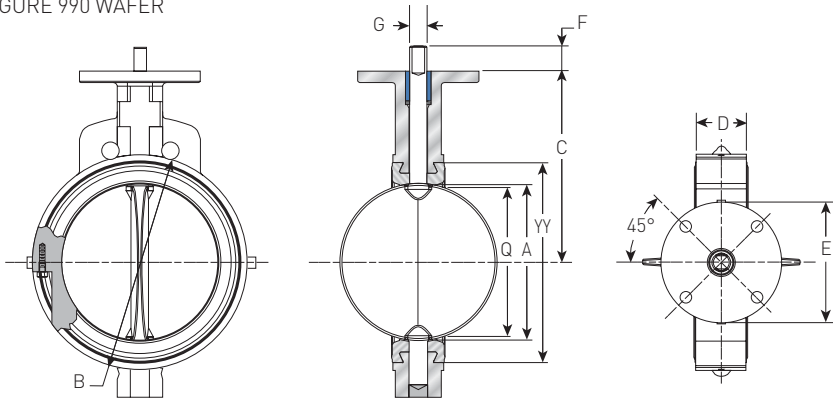
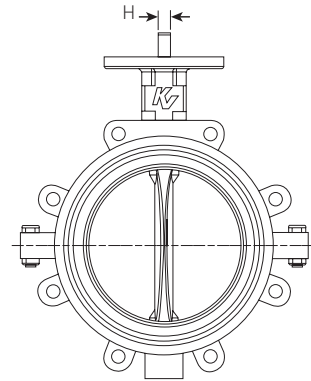

FIGURE 920 LUG



CAST AND DUCTILE IRON BODY (mm)

Size DN	A	B	C	D	E	F	G	H ^[1]	YY	Q ^[3]	Top plate drilling			Tapped lug data			Weight (kg)		Adapt code	
											Key	Bolt circle	No. holes	Hole dia.	Bolt circle	No. holes	Tap size	990		920
25	30	62	79	29	57	19	9.53	6.35	50	16	N/A	44.5	4	7.1	N/A	N/A	N/A	0.7	N/A	AAA
40	44	82	94	30	57	19	9.53	6.35	67	37	N/A	44.5	4	7.1	N/A	N/A	N/A	1.0	N/A	AAA
50	51	105	140	41	102	32	14.29	9.53	87	35	N/A	82.6	4	11.1	120.7	4	5/8 - 11 UNC	2.7	3.2	BAB
65	64	117	152	44	102	32	14.29	9.53	98	52	N/A	82.6	4	11.1	139.7	4	5/8 - 11 UNC	3.6	4.4	BAB
80	76	130	159	44	102	32	14.29	9.53	114	65	N/A	82.6	4	11.1	152.4	4	5/8 - 11 UNC	4.1	4.5	BAB
100	102	162	178	51	102	32	15.88	11.11	146	92	N/A	82.6	4	11.1	190.5	8	5/8 - 11 UNC	5.0	7.6	BAC
125	127	187	191	54	102	32	19.05	12.70	168	121	N/A	82.6	4	11.1	215.9	8	3/4 - 10 UNC	7.0	10.0	BAD
150	146	216	203	54	102	32	19.05	12.70	197	140	N/A	82.6	4	11.1	241.3	8	3/4 - 10 UNC	8.0	11.0	BAD
200	197	271	241	64	152	32	22.23	15.88	254	191	N/A	127.0	4	14.3	298.5	8	3/4 - 10 UNC	14.0	19.0	CAE
250	248	330	273	64	152	51	28.58	N/A	305	244	6.4 x 6.4	127.0	4	14.3	362.0	12	7/8 - 9 UNC	20.0	29.0	CAF
300	298	376	311	76	152	51	28.58	N/A	353	294	6.4 x 6.4	127.0	4	14.3	431.8	12	7/8 - 9 UNC	35.0	49.0	CAF
350	339	429	305	76	152	76 ^[4]	34.93 ^[4]	N/A	403	333	8.0 x 8.0 ^[4]	127.0	4	14.3	476.3	12	1 - 8 UNC	48.0	65.0	CAG
400	391	483	329	102	152	76 ^[5]	41.28	N/A	464	381	9.5 x 9.5 ^[5]	127.0	4	14.3	539.8	16	1 - 8 UNC	82.0	108.0	CAH
450	441	543	368	108	203	108 ^[6]	47.63	N/A	521	432	12.7 x 9.5	165.1	4	20.6	577.9	16	1 1/8 - 7 UNC	101.0	118.0	DAJ
500	492	597	403	127	203	108 ^[7]	47.63	N/A	575	479	12.7 x 9.5	165.1	4	20.6	635.0	20	1 1/8 - 7 UNC	143.0	166.0	DAJ

STAINLESS STEEL BODY (mm)

Size DN	A	B	C	D	E	F	G	H ^[1]	YY	Q ^[3]	Top plate drilling			Tapped lug data			Weight (kg)		Adapt code
											Bolt circle	No. holes	Hole dia.	Bolt circle	No. holes	Tap size	990	920	
25	30	60	79	29	89	19	9.53	6.35	50	16	44.5	4	7.9	N/A	N/A	N/A	0.6	N/A	AAA
40	44	76	95	30	89	19	9.53	6.35	67	37	44.5	4	7.9	N/A	N/A	N/A	0.8	N/A	AAA
50	51	98	140	41	78	32	14.29	9.53	87	35	82.6	4	11.1	120.7	4	5/8 - 11 UNC	1.7	2.4	BAB
80	76	127	159	44	78	32	14.29	9.53	114	65	82.6	4	11.1	152.4	4	5/8 - 11 UNC	2.7	3.3	BAB
100	102	159	178	51	78	32	15.88	11.11	146	92	82.6	4	11.1	190.5	8	5/8 - 11 UNC	3.9	6.1	BAC
150	146	210	203	54	78	32	19.05	12.70	168	140	82.6	4	11.1	241.3	8	3/4 - 10 UNC	5.9	8.6	BAD

NOTES

- "H" dimension refers to flat on stem.
 - DN 25 and DN 40 valve assemblies with stainless steel body are furnished with integral 10-position throttling plate.
 - "Q" dimension is the minimum allowable pipe or flange inside diameter at the centered body face to protect the disc sealing edge against damage when opening the valve.
 - For EU version stem, refer to these sizes: 350 mm size: F = 51 mm, G = 28.58 mm, Key = 6.4 x 6.4 mm.
 - For EU version stem, refer to these sizes: 400 mm size: F = 51 mm, Key = 12.7 x 9.5 mm.
 - For EU version stem, refer to these sizes: 450 mm size: F = 57 mm.
 - For EU version stem, refer to these sizes: 500 mm size: F = 57 mm.
- N/A = Not available

KEYSTONE FIGURE 990 AND 920 RESILIENT SEATED BUTTERFLY VALVES

IMPERIAL DATA

FIGURE 990 WAFER

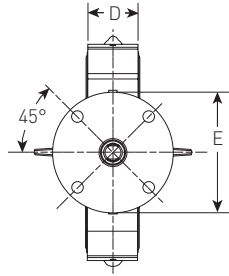
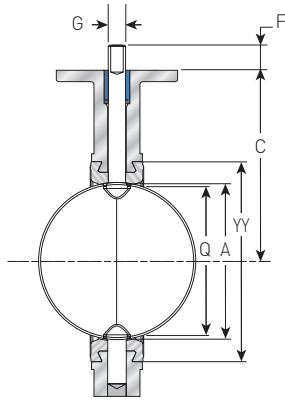
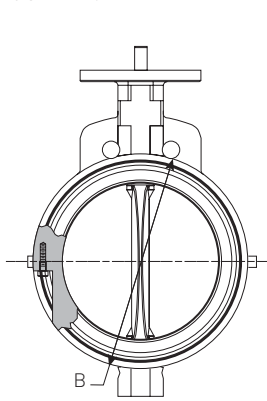
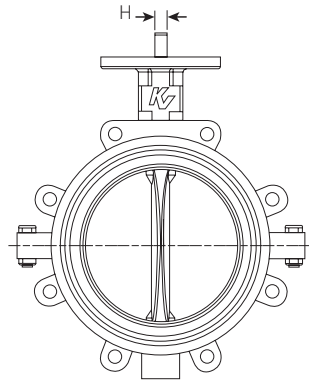

FIGURE 920 LUG



CAST AND DUCTILE IRON BODY (inches)

Size NPS	A	B	C	D	E	F	G	H ^[1]	YY	Q ^[3]	Top plate drilling				Tapped lug data			Weight (lbs.)		Adapt code
											Key	Bolt circle	No. holes	Hole dia.	Bolt circle	No. holes	Tap size	990	920	
1	1 ³ / ₁₆	2 ⁷ / ₁₆	3 ¹ / ₈	1 ¹ / ₈	2 ¹ / ₄	3 ¹ / ₄	3 ¹ / ₈	1 ¹ / ₄	1 ³ / ₄	5 ¹ / ₈	N/A	1 ³ / ₄	4	5 ¹ / ₃₂	N/A	N/A	N/A	1 ¹ / ₂	N/A	AAA
1 ¹ / ₂	1 ³ / ₄	3 ⁷ / ₃₂	3 ²³ / ₃₂	1 ³ / ₁₆	2 ¹ / ₄	3 ¹ / ₄	3 ¹ / ₈	1 ¹ / ₄	2 ¹ / ₂	1 ⁷ / ₁₆	N/A	1 ³ / ₄	4	5 ¹ / ₃₂	N/A	N/A	N/A	2 ¹ / ₄	N/A	AAA
2	2	4 ¹ / ₈	5 ¹ / ₂	1 ⁵ / ₈	4	1 ¹ / ₄	3 ¹ / ₁₆	3 ¹ / ₈	3	1 ³ / ₈	N/A	3 ¹ / ₄	4	7 ¹ / ₁₆	4 ³ / ₄	4	5 ¹ / ₈ - 11 UNC	6	7	BAB
2 ¹ / ₂	2 ¹ / ₂	4 ⁵ / ₈	6	1 ³ / ₄	4	1 ¹ / ₄	3 ¹ / ₁₆	3 ¹ / ₈	3 ¹ / ₂	2 ¹ / ₁₆	N/A	3 ¹ / ₄	4	7 ¹ / ₁₆	5 ¹ / ₂	4	5 ¹ / ₈ - 11 UNC	8	9 ³ / ₄	BAB
3	3	5 ¹ / ₈	6 ¹ / ₄	1 ³ / ₄	4	1 ¹ / ₄	3 ¹ / ₁₆	3 ¹ / ₈	4 ¹ / ₂	2 ¹ / ₁₆	N/A	3 ¹ / ₄	4	7 ¹ / ₁₆	6	4	5 ¹ / ₈ - 11 UNC	9	10	BAB
4	4	6 ³ / ₈	7	2	4	1 ¹ / ₄	3 ¹ / ₈	7 ¹ / ₁₆	5	3 ³ / ₈	N/A	3 ¹ / ₄	4	7 ¹ / ₁₆	7 ¹ / ₂	8	5 ¹ / ₈ - 11 UNC	11	16 ³ / ₄	BAC
5	5	7 ³ / ₈	7 ¹ / ₂	2 ¹ / ₈	4	1 ¹ / ₄	3 ¹ / ₄	1 ¹ / ₂	6	4 ³ / ₄	N/A	3 ¹ / ₄	4	7 ¹ / ₁₆	8 ¹ / ₂	8	3 ¹ / ₄ - 10 UNC	15 ¹ / ₂	22	BAD
6	5 ³ / ₄	8 ¹ / ₂	8	2 ¹ / ₈	4	1 ¹ / ₄	3 ¹ / ₄	1 ¹ / ₂	6	5 ¹ / ₂	N/A	3 ¹ / ₄	4	7 ¹ / ₁₆	9 ¹ / ₂	8	3 ¹ / ₄ - 10 UNC	17 ¹ / ₂	24 ¹ / ₄	BAD
8	7 ³ / ₄	10 ¹¹ / ₁₆	9 ¹ / ₂	2 ¹ / ₂	6	1 ¹ / ₄	7 ¹ / ₈	5 ¹ / ₈	10	7 ¹ / ₂	N/A	5	4	5 ¹ / ₁₆	11 ³ / ₄	8	3 ¹ / ₄ - 10 UNC	30	42	CAE
10	9 ³ / ₄	13	10 ³ / ₄	2 ¹ / ₂	6	2	1 ¹ / ₈	N/A	12	9 ¹⁹ / ₃₂	1 ¹ / ₄ x 1 ¹ / ₄	5	4	5 ¹ / ₁₆	14 ¹ / ₄	12	7 ¹ / ₈ - 9 UNC	45	65	CAF
12	11 ³ / ₄	14 ¹³ / ₁₆	12 ¹ / ₄	3	6	2	1 ¹ / ₈	N/A	13 ⁹ / ₁₀	11 ¹ / ₁₆	1 ¹ / ₄ x 1 ¹ / ₄	5	4	5 ¹ / ₁₆	17	12	7 ¹ / ₈ - 9 UNC	78	108	CAF
14	13 ²³ / ₆₄	16 ⁷ / ₈	12	3	6	3 ^[4]	1 ³ / ₈ ^[4]	N/A	15 ⁹ / ₁₀	13 ¹ / ₈	5 ¹ / ₁₆ x 5 ¹ / ₁₆ ^[4]	5	4	5 ¹ / ₁₆	18 ³ / ₄	12	1 - 8 UNC	105	143	CAG
16	15 ³ / ₈	19	12 ¹⁵ / ₁₆	4	6	3 ^[5]	1 ⁵ / ₈	N/A	18 ⁹ / ₁₀	15	3 ¹ / ₈ x 3 ¹ / ₈ ^[5]	5	4	5 ¹ / ₁₆	21 ¹ / ₄	16	1 - 8 UNC	180	238	CAH
18	17 ³ / ₈	21 ³ / ₈	14 ¹ / ₂	4 ¹ / ₄	8	4 ¹ / ₄ ^[6]	1 ⁷ / ₈	N/A	21 ¹ / ₂	17	1 ¹ / ₂ x 3 ¹ / ₈	6 ¹ / ₂	4	1 ³ / ₁₆	22 ³ / ₄	16	1 ¹ / ₈ - 7 UNC	222	261	DAJ
20	19 ³ / ₈	23 ¹ / ₂	15 ⁷ / ₈	5	8	4 ¹ / ₄ ^[7]	1 ⁷ / ₈	N/A	22 ³ / ₈	18 ⁷ / ₈	1 ¹ / ₂ x 3 ¹ / ₈	6 ¹ / ₂	4	1 ³ / ₁₆	25	20	1 ¹ / ₈ - 7 UNC	315	366	DAJ

STAINLESS STEEL BODY (inches)

Size NPS	A	B	C	D	E	F	G	H ^[1]	YY	Q ^[3]	Top plate drilling			Tapped lug data			Weight (lbs.)		Adapt code
											Bolt circle	No. holes	Hole dia.	Bolt circle	No. holes	Tap size	990	920	
1	1 ³ / ₁₆	2 ³ / ₈	3 ¹ / ₈	1 ¹ / ₈	3 ¹ / ₂	3 ¹ / ₄	3 ¹ / ₈	1 ¹ / ₄	1 ³ / ₄	5 ¹ / ₈	1 ³ / ₄	4	5 ¹ / ₁₆	N/A	N/A	N/A	1 ¹ / ₄	N/A	AAA
1 ¹ / ₂	1 ³ / ₄	3	3 ³ / ₄	1 ³ / ₁₆	3 ¹ / ₂	3 ¹ / ₄	3 ¹ / ₈	1 ¹ / ₄	2 ¹ / ₂	1 ⁷ / ₁₆	1 ³ / ₄	4	5 ¹ / ₁₆	N/A	N/A	N/A	1 ³ / ₄	N/A	AAA
2	2	3 ⁷ / ₈	5 ¹ / ₂	1 ⁵ / ₈	3 ¹ / ₁₆	1 ¹ / ₄	3 ¹ / ₁₆	3 ¹ / ₈	3	1 ³ / ₈	3 ¹ / ₄	4	7 ¹ / ₁₆	4 ³ / ₄	4	5 ¹ / ₈ - 11 UNC	3 ³ / ₄	5 ¹ / ₄	BAB
3	3	5	6 ¹ / ₄	1 ³ / ₄	3 ¹ / ₁₆	1 ¹ / ₄	3 ¹ / ₁₆	3 ¹ / ₈	3 ¹ / ₂	2 ¹ / ₁₆	3 ¹ / ₄	4	7 ¹ / ₁₆	6	4	5 ¹ / ₈ - 11 UNC	6	7 ¹ / ₄	BAB
4	4	6 ¹ / ₄	7	2	3 ¹ / ₁₆	1 ¹ / ₄	3 ¹ / ₈	7 ¹ / ₁₆	4 ¹ / ₂	3 ³ / ₈	3 ¹ / ₄	4	7 ¹ / ₁₆	7 ¹ / ₂	8	5 ¹ / ₈ - 11 UNC	8 ¹ / ₂	13 ¹ / ₂	BAC
6	5 ³ / ₄	8 ¹ / ₄	8	2 ¹ / ₈	3 ¹ / ₁₆	1 ¹ / ₄	3 ¹ / ₄	1 ¹ / ₂	6	5 ¹ / ₂	3 ¹ / ₄	4	7 ¹ / ₁₆	9 ¹ / ₂	8	3 ¹ / ₄ - 10 UNC	13	19	BAD

NOTES

- "H" dimension refers to flat on stem.
 - NPS 1 and NPS 1¹/₂ valve assemblies with stainless steel body are furnished with integral 10-position throttling plate.
 - "Q" dimension is the minimum allowable pipe or flange inside diameter at the centered body face to protect the disc sealing edge against damage when opening the valve
 - For EU version stem, refer to these sizes: 14 in. size: F = 2¹/₁₆ in., G = 1¹/₈ in., Key = 1¹/₄ x 1¹/₄ in.
 - For EU version stem, refer to these sizes: 16 in. size: F = 2¹/₁₆ in., Key = 1¹/₂ x 3¹/₈ in.
 - For EU version stem, refer to these sizes: 18 in. size: F = 2¹/₄ in.
 - For EU version stem, refer to these sizes: 20 in. size: F = 2¹/₄ in.
- N/A = Not available

KEYSTONE FIGURE 990 AND 920 RESILIENT SEATED BUTTERFLY VALVES

FLOW CONTROL CHARACTERISTICS

While most butterfly valves achieve an equal percentage characteristic, the Keystone thin-profile disc design does so at a significantly higher capacity through the valve's full travel. This results in not only 100:1 rangeability (Maximum K_v or C_v /Minimum K_v or C_v), but also greatly increased turndown ratio (Maximum Flow/Minimum Flow).

FLOW COEFFICIENT (K_v)

Valve size DN	Angle of disc opening								
	10°	20°	30°	40°	50°	60°	70°	80°	90°
25	0.06	0.6	2.4	4.2	7.2	11.2	21	36	77
40	0.14	1.4	5.6	9.9	17.3	27.0	48	76	140
50	0.26	2.3	9.3	16.2	28.0	44.0	79	139	231
65	0.39	3.9	15.6	28.0	47.0	74.0	132	236	390
80	0.61	6.0	24.0	42.0	72.0	114.0	203	362	599
100	1.12	11.3	45.0	80.0	137.0	216.0	387	688	1137
125	1.82	18.3	73.0	128.0	219.0	346.0	620	1103	1823
150	2.42	24.0	97.0	169.0	290.0	458.0	734	1462	2413
200	4.50	45.0	180.0	316.0	541.0	856.0	1531	2725	4505
250	7.18	72.0	287.0	503.0	862.0	1367.0	2444	4347	7186
300	10.38	104.0	416.0	728.0	1246.0	1977.0	3538	6293	10406
350	12.98	130.0	519.0	908.0	1557.0	2465.0	4412	7850	12975
400	17.30	173.0	690.0	1208.0	2072.0	3280.0	5872	10445	17265
450	22.32	223.0	893.0	1561.0	2677.0	4239.0	7584	13494	22308
500	27.85	279.0	1116.0	1952.0	3348.0	5298.0	9480	16868	27888

Note: K_v = The volume of water in cubic meters per hour that will pass through a valve with a pressure drop of 1 bar at 20°C.

FLOW COEFFICIENT (C_v)

Valve size NPS	Angle of disc opening								
	10°	20°	30°	40°	50°	60°	70°	80°	90°
1	0.07	0.7	2.8	4.8	8.3	13	24	42	89
1½	0.16	1.6	6.5	11.4	20.0	31	55	88	162
2	0.30	2.7	10.7	18.7	32.0	51	91	161	267
2½	0.45	4.5	18.0	32.0	54.0	86	153	273	451
3	0.70	6.9	27.7	49.0	83.0	132	235	419	693
4	1.30	13.1	52.6	92.0	158.0	250	447	795	1314
5	2.10	21.1	84.3	148.0	253.0	400	717	1275	2108
6	2.80	27.9	112.0	195.0	335.0	530	848	1690	2790
8	5.20	52.1	208.0	365.0	625.0	990	1770	3150	5208
10	8.30	83.1	332.0	582.0	997.0	1580	2825	5025	8308
12	12.00	120.0	481.0	842.0	1440.0	2286	4090	7275	12030
14	15.00	150.0	600.0	1050.0	1800.0	2850	5100	9075	15000
16	20.00	200.0	798.0	1397.0	2395.0	3792	6788	12075	19960
18	25.80	258.0	1032.0	1805.0	3095.0	4900	8768	15600	25790
20	32.20	322.0	1290.0	2257.0	3870.0	6125	10960	19500	32240

Note: C_v = The volume of water in US gallons per minute that will pass through a valve with a pressure drop of 1 psi at 70°F.

DYNAMIC TORQUE FACTORS F_T FOR METRIC UNITS

Disc opening	Size in mm										
	25	40	50	65	80	100	125	150	200	250	300
10°	0.08	0.2	0.5	0.9	1.2	2.7	4.3	6.1	13	28	39
20°	0.10	0.2	0.7	1.0	1.5	3.4	5.9	8.7	20	40	61
30°	0.11	0.3	0.8	1.3	2.1	4.8	8.4	13.0	30	61	95
40°	0.15	0.5	1.0	1.5	3.0	6.4	12.0	20.0	47	94	153
50°	0.20	0.7	1.5	2.6	4.3	10.0	19.0	30.0	71	141	230
60°	0.25	0.8	2.1	3.9	6.4	15.0	29.0	48.0	112	220	380
70°	0.41	1.3	3.1	5.9	10.0	24.0	45.0	76.0	176	350	610
80°	0.57	1.8	4.4	8.5	14.0	34.0	65.0	112.0	260	520	890

THIN DISC FLOW CONTROL

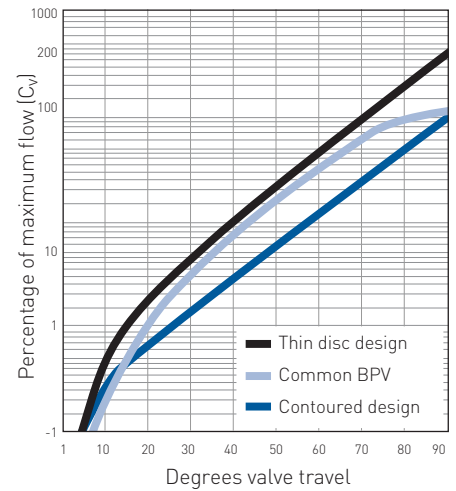

NOTES

- Dynamic operating torque formula:
 $T_D = F_T \times \Delta P$
 T_D = Dynamic torque (Nm)
 ΔP = Pressure drop across disc air desired disc-opening (bar)
 F_T = Dynamic torque factor (see table)
- The dynamic torque includes all frictional resistances.
- The dynamic torque is tending to close the disc.
- The charted maximum allowable torques are only applicable for standard type valves.

KEYSTONE FIGURE 990 AND 920 RESILIENT SEATED BUTTERFLY VALVES

FIGURE 990/920 SEATING AND UNSEATING TORQUES (Nm)

Application ΔP	Valve size (DN)														
	25	40	50	65	80	100	125	150	200	250	300	350	400	450	500
I															
0	4	7	12	15	18	27	37	51	85	130	175	243	311	390	480
3.5	6	10	14	16	20	31	42	62	107	164	232	333	446	593	763
7	7	11	15	18	23	34	48	73	130	198	288	424	582	797	1045
10	8	12	16	19	25	37	54	85	153	232	345	514	718	1000	1328
3.5 (U/C)	-	-	-	-	-	19	25	35	57	85	113	164	209	266	322
II															
0	6	9	25	31	36	54	73	102	170	260	350	486	622	780	961
3.5	8	12	26	32	38	58	79	113	192	294	407	576	757	983	1243
7	9	13	27	33	41	61	85	124	215	328	463	667	893	1187	1526
10	10	14	28	34	43	64	90	136	237	362	520	757	1028	1390	1808
3.5 (U/C)	-	-	-	-	-	41	55	80	136	203	283	418	554	735	927
III															
0	8	11	37	46	54	81	110	153	254	390	525	729	932	1170	1441
3.5	10	14	38	46	57	85	116	164	277	424	582	819	1068	1373	1723
7	11	16	40	47	59	88	121	175	299	458	638	910	1203	1576	2006
10	12	17	41	49	61	103	127	186	322	492	695	1000	1339	1780	2288
3.5 (U/C)	-	-	-	-	-	59	80	115	192	288	396	582	763	1000	1249

FIGURE 990/920 SEATING AND UNSEATING TORQUES (in Lbs.)

Application ΔP	Valve size (NPS)														
	1	1½	2	2½	3	4	5	6	8	10	12	14	16	18	20
I															
0	35	60	110	135	160	240	325	450	750	1150	1550	2150	2750	3450	4250
50	55	90	120	145	180	270	375	550	950	1450	2050	2950	3950	5250	6750
100	60	100	130	155	200	300	425	650	1150	1750	2550	3750	5150	7050	9250
150	70	105	140	165	220	330	475	750	1350	2050	3050	4550	6350	8850	11750
50 (U/C)	-	-	-	-	-	165	220	306	500	750	1000	1450	1850	2350	2850
II															
0	55	80	220	270	320	480	650	900	1500	2300	3100	4300	5500	6900	8500
50	70	105	230	280	340	510	700	1000	1700	2600	3600	5100	6700	8700	11000
100	80	115	240	290	360	540	750	1100	1900	2900	4100	5900	7900	10500	13500
150	90	125	250	300	380	570	800	1200	2100	3200	4600	6700	9100	12300	16000
50 (U/C)	-	-	-	-	-	360	490	710	1200	1800	2500	3700	4900	6500	8200
III															
0	70	100	330	405	480	720	975	1350	2250	3450	4650	6450	8250	10350	12750
50	90	125	340	410	500	750	1025	1450	2450	3750	5150	7250	9450	12150	15250
100	100	140	350	420	520	780	1075	1550	2650	4050	5650	8050	10650	13950	17750
150	105	150	360	430	540	910	1125	1650	2850	4350	6150	8850	11850	15750	20250
50 (U/C)	-	-	-	-	-	525	710	1015	1700	2550	3500	5150	6750	8850	11050

TORQUE APPLICATION FACTOR CATEGORIES

Application I

Clean liquid lubricating media (water, clean oils, lube oil, mineral oil, etc.); and with no deposit or chemical attack, valve operated at least once a week. Temperature range from 0°C (32°F) to maximum temperature rating of the elastomer seat. For PTFE seats, use additional 35% for safety factor.

Application II

Other liquid media and lubricating gases (aqueous liquids, such as food and beverage, water, etc.); and with minor deposit or chemical attack, valve operated at least once a month. Temperature range from 0°C (32°F) to maximum temperature rating of the elastomer seat.

Application III

a. Dry non-abrasive media or gases (non-abrasive powders and dry gas); or
 b. Fluids with moderate deposit or chemical attack; or
 c. Valves operated less than once a month.
 Temperature range from 0°C (32°F) to maximum temperature rating of the elastomer seat.

NOTES

1. For applications with temperatures above or below the guidelines above, please consult factory.

KEYSTONE FIGURE 990 AND 920 RESILIENT SEATED BUTTERFLY VALVES

MAXIMUM ALLOWABLE STEM TORQUE (MAST) FOR FIGURE 990, Nm

Disc-Stem	Stem material	Size (DN)														
		25	40	50	65	80	100	125	150	200	250	300	350	400	450	500
Stainless, Mirror polished, Brushed finish, Satin finish	1.4408	16	16 ⁽⁴⁾	54	54	54	80	128	128 ⁽²⁾	226 ⁽²⁾	715	642 ⁽⁵⁾	-	-	-	-
Duplex	1.4470	-	-	-	-	-	-	-	257	453	1486	-	-	-	-	
PTFE-coated, EPDM-coated	1.4462	-	-	116	116	116	172	275	275	485	1080	971	-	-	-	
Stainless, Mirror polished, Satin finish, and PTFE-coated (Fabricated for non-PED valves)	316L	-	-	-	-	-	-	-	-	-	-	-	CF	CF	CF	CF
Stainless, Mirror polished, Satin finish (Pinned version for PED valves)	1.4301 ⁽¹⁾	-	-	-	-	-	-	-	-	-	-	-	821 ⁽³⁾	1853	2162	2525

NOTES

1. For mirror polished/satin finish disc, please contact factory.
2. For Application II, 10 bar, please contact factory.
3. For Application III, 7 bar, please contact factory.
4. For Application III, 10 bar, please contact factory.
5. For Application II and III, 10 bar, please contact factory. (MAST 10 bar = 480 Nm)

MAXIMUM ALLOWABLE STEM TORQUE (MAST) FOR FIGURE 990, lbf-in

Disc-Stem	Stem material	Size (NPS)														
		1	1½	2	2½	3	4	5	6	8	10	12	14	16	18	20
Stainless, Mirror polished, Brushed finish, Satin finish	1.4408	142	142 ⁽⁴⁾	478	478	478	708	1133	1133 ⁽²⁾	2001 ⁽²⁾	6329	5682 ⁽⁵⁾	-	-	-	-
Duplex	1.4470	-	-	-	-	-	-	-	2275	4010	13153	-	-	-	-	
PTFE-coated, EPDM-coated	1.4462	-	-	1027	1027	1027	1523	2434	2434	4293	9559	8594	-	-	-	
Stainless, Mirror polished, Satin finish, and PTFE-coated (Fabricated for non-PED valves)	316L	-	-	-	-	-	-	-	-	-	-	-	CF	CF	CF	CF
Stainless, Mirror polished, Satin finish (Pinned version for PED valves)	1.4301 ⁽¹⁾	-	-	-	-	-	-	-	-	-	-	-	7267 ⁽³⁾	16401	19136	22349

NOTES

1. For mirror polished/satin finish disc, please contact factory.
2. For Application II, 145 psig, please contact factory.
3. For Application III, 102 psig, please contact factory.
4. For Application III, 145 psig, please contact factory.
5. For Application II and III, 145 psig please contact factory. (MAST 145 psig = 4249 lbf-in.)

KEYSTONE FIGURE 990 AND 920 RESILIENT SEATED BUTTERFLY VALVES

METRIC DATA

PRESSURE-TEMPERATURE DIAGRAM — NON-PED

Size	Disc material	Body material	Temperature (°C)										
			-29	-15	-10	0	20	40	80	100	120	150	160
Up to DN 300	EPDM	316 Stainless steel (As Cast, Mirror, Satin, Brushed), Duplex					10 bar						
		EPDM Covered					7 bar						
	NBR White NBR	316 Stainless steel (As Cast, Mirror, Satin, Brushed), Duplex					10 bar						
		NBR Covered					7 bar						
	FKM	316 Stainless steel (As Cast, Mirror, Satin, Brushed), Duplex					10 bar						
		316 Stainless steel (As Cast, Mirror, Satin, Brushed), Duplex					10 bar					1 bar	
	PTFE/EPDM	316 Stainless steel (As Cast, Mirror, Satin, Brushed), Duplex					10 bar					1 bar	
PTFE Covered						7 bar					1 bar		
PTFE/NBR	316 Stainless steel (As Cast, Mirror, Satin, Brushed), Duplex					10 bar							
	PTFE Covered					7 bar							
Polyurethane	316 Stainless steel (As Cast, Mirror, Satin, Brushed), Duplex, Urethane coated, Ceramic					7 bar							
	316 Stainless steel (As Cast, Mirror, Satin, Brushed), Duplex					5 bar							
DN 350 and above	EPDM	316 Stainless steel (As Cast, Mirror, Satin, Brushed), Duplex					5 bar						
		EPDM Covered					5 bar						
	NBR White NBR	316 Stainless steel (As Cast, Mirror, Satin, Brushed), Duplex					5 bar						
		NBR Covered					5 bar						
	FKM	316 Stainless steel (As Cast, Mirror, Satin, Brushed), Duplex					5 bar						
		316 Stainless steel (As Cast, Mirror, Satin, Brushed), Duplex					5 bar					1 bar	
	PTFE/EPDM	316 Stainless steel (As Cast, Mirror, Satin, Brushed), Duplex					5 bar					1 bar	
PTFE Covered						5 bar					1 bar		
PTFE/NBR	316 Stainless steel (As Cast, Mirror, Satin, Brushed), Duplex					5 bar							
	PTFE Covered					5 bar							
Polyurethane	316 Stainless steel (As Cast, Mirror, Satin, Brushed), Duplex, Urethane coated, Ceramic					5 bar							

NOTE

This Pressure-Temperature data applies to Non-PED valves. For the PED version, please see table below.

PRESSURE-TEMPERATURE DIAGRAM — PED

Size	Disc material	Body material	Temperature (°C)										
			-29	-15	-10	0	20	40	80	100	120	150	160
Up to DN 300	EPDM	316 Stainless steel (As Cast, Mirror, Satin, Brushed), Duplex					10 bar						
		EPDM Covered					10 bar						
	NBR White NBR	316 Stainless steel (As Cast, Mirror, Satin, Brushed), Duplex					10 bar						
		NBR Covered					10 bar						
	FKM	316 Stainless steel (As Cast, Mirror, Satin, Brushed), Duplex					10 bar						
		316 Stainless steel (As Cast, Mirror, Satin, Brushed), Duplex					10 bar					2 bar	
	PTFE/EPDM	316 Stainless steel (As Cast, Mirror, Satin, Brushed), Duplex					10 bar					1 bar	
PTFE Covered						10 bar							
PTFE/NBR	316 Stainless steel (As Cast, Mirror, Satin, Brushed), Duplex					10 bar							
	PTFE Covered					-							
Polyurethane	316 Stainless steel (As Cast, Mirror, Satin, Brushed), Duplex, Urethane coated, Ceramic					7 bar							
	316 Stainless steel (As Cast, Mirror, Satin, Brushed), Duplex					10 bar							
DN 350 and above	EPDM	316 Stainless steel (As Cast, Mirror, Satin, Brushed), Duplex					10 bar						
		EPDM Covered					-						
	NBR White NBR	316 Stainless steel (As Cast, Mirror, Satin, Brushed), Duplex					10 bar						
		NBR Covered					-						
	FKM	316 Stainless steel (As Cast, Mirror, Satin, Brushed)					10 bar						
PTFE/EPDM	316 Stainless steel (As Cast, Mirror, Satin, Brushed)					10 bar					2 bar		

KEYSTONE FIGURE 990 AND 920 RESILIENT SEATED BUTTERFLY VALVES

IMPERIAL DATA

PRESSURE-TEMPERATURE DIAGRAM — NON-PED

Size	Disc material	Body material	Temperature (°F)											
			-20.2	5	14	32	68	104	176	212	248	302	320	
Up to NPS 12	EPDM	316 Stainless steel (As Cast, Mirror, Satin, Brushed), Duplex						150 psi						
		EPDM Covered						100 psi						
	NBR White NBR	316 Stainless steel (As Cast, Mirror, Satin, Brushed), Duplex						150 psi						
		NBR Covered						100 psi						
	FKM	316 Stainless steel (As Cast, Mirror, Satin, Brushed), Duplex						150 psi						
	PTFE/EPDM	316 Stainless steel (As Cast, Mirror, Satin, Brushed), Duplex						150 psi				15 psi		
		PTFE Covered						100 psi				15 psi		
PTFE/NBR	316 Stainless steel (As Cast, Mirror, Satin, Brushed), Duplex						150 psi							
	PTFE Covered						100 psi							
	Polyurethane	316 Stainless steel (As Cast, Mirror, Satin, Brushed), Duplex, Urethane coated, Ceramic						100 psi						
NPS 14 and above	EPDM	316 Stainless steel (As Cast, Mirror, Satin, Brushed), Duplex						75 psi						
		EPDM Covered						75 psi						
	NBR White NBR	316 Stainless steel (As Cast, Mirror, Satin, Brushed), Duplex						75 psi						
		NBR Covered						75 psi						
	FKM	316 Stainless steel (As Cast, Mirror, Satin, Brushed), Duplex						75 psi						
	PTFE/EPDM	316 Stainless steel (As Cast, Mirror, Satin, Brushed), Duplex						75 psi				15 psi		
		PTFE Covered						75 psi				15 psi		
PTFE/NBR	316 Stainless steel (As Cast, Mirror, Satin, Brushed), Duplex						75 psi							
	PTFE Covered						75 psi							
	Polyurethane	316 Stainless steel (As Cast, Mirror, Satin, Brushed), Duplex, Urethane coated, Ceramic						75 psi						

NOTE

This Pressure-Temperature data applies to Non-PED valves. For the PED version, please see table below.

PRESSURE-TEMPERATURE DIAGRAM — PED

Size	Disc material	Body material	Temperature (°F)											
			-20.2	5	14	32	68	104	176	212	248	302	320	
Up to NPS 12	EPDM	316 Stainless steel (As Cast, Mirror, Satin, Brushed), Duplex						150 psi						
		EPDM Covered						150 psi						
	NBR White NBR	316 Stainless steel (As Cast, Mirror, Satin, Brushed), Duplex						150 psi						
		NBR Covered						150 psi						
	FKM	316 Stainless steel (As Cast, Mirror, Satin, Brushed), Duplex						150 psi						
	PTFE/EPDM	316 Stainless steel (As Cast, Mirror, Satin, Brushed), Duplex						150 psi				29 psi		
		PTFE Covered						150 psi				15 psi		
PTFE/NBR	316 Stainless steel (As Cast, Mirror, Satin, Brushed), Duplex						150 psi							
	PTFE Covered						-							
	Polyurethane	316 Stainless steel (As Cast, Mirror, Satin, Brushed), Duplex, Urethane coated, Ceramic						100 psi						
NPS 14 and above	EPDM	316 Stainless steel (As Cast, Mirror, Satin, Brushed), Duplex						150 psi						
		EPDM Covered						-						
	NBR White NBR	316 Stainless steel (As Cast, Mirror, Satin, Brushed), Duplex						150 psi						
		NBR Covered						-						
	FKM	316 Stainless steel (As Cast, Mirror, Satin, Brushed)						150 psi						
PTFE/EPDM	316 Stainless steel (As Cast, Mirror, Satin, Brushed)						150 psi				29 psi			

KEYSTONE FIGURE 990 AND 920 RESILIENT SEATED BUTTERFLY VALVES

SELECTION GUIDE

Example:	920L	0100	- IO	S0	S0	E0	A1	K	- 00	000	00
Series	900										
Body style											
920L	Lug										
990W	Wafer										
Size											
0025	DN 25/NPS 1 ⁽¹⁾	0200	DN 200/NPS 8								
0040	DN 40/NPS 1½ ⁽¹⁾	0250	DN 250/NPS 10								
0050	DN 50/NPS 2	0300	DN 300/NPS 12								
0065	DN 65/NPS 2½	0350	DN 350/NPS 14								
0080	DN 80/NPS 3	0400	DN 400/ NPS 16								
0100	DN 100/NPS 4	0450	DN 450/NPS 18								
0125	DN 125/NPS 5	0500	DN 500/NPS 20								
0150	DN 150/NPS 6										
Body											
I0	Cast iron										
I3	Cast iron - ENP										
D2	Ductile iron A395 ⁽⁴⁾										
S0	316 stainless steel ⁽²⁾										
Disc											
S0	316 stainless steel	E0	EPDM molded CS ⁽³⁾								
S3	316 stainless steel mirror polish	E1	NBR molded CS ⁽³⁾								
S6	316 stainless steel brushed finish	E2	PTFE molded CS ⁽³⁾								
S7	316 stainless steel - ceramic ctd	E6	PTFE molded SS ⁽³⁾								
U0	Duplex	E3	Urethane molded CS								
V0	Super duplex	H0	Hastelloy® C276								
Shaft											
S0	316 stainless steel	V0	Super duplex								
U0	Duplex	H0	Hastelloy® C276								
Seat											
E0	EPDM FG	T1	PTFE/EPDM								
N0	NBR FG	T2	PTFE/NBR								
N9	White NBR	T3	PTFE/EPDM green								
F1	FKM	U1	Urethane (red)								
Flange drilling											
Single drilled lug and wafer											
A1	ASME 125/150	M2	PN10/16 ASME 150, BS E								
AE	AS2129 table E	M3	ASME 150/AS2129 table E								
AD	AS 4087 PN16/AS2129 table D	M4	ASME 150/DIN (PN6,10,16)								
		M6	ASME 150/AS2129 E/AS4087 PN16								
Actuator mounting											
K	Keystone mount										
Actuation											
00	None	G1	Gear - blue								
H1	10 pos handle - blue	G5	Chainwheel - blue								
Special											
000	None	A00	Weep holes and U/C disc								
002	Weep holes	A01	Bearings and U/C disc								
003	Weep holes and slotted stem	P04	Reduced disc for 50 psi								
009	Silicone free	C22	NSF/ANSI std 61								
017	Bearings										
Coating											
00	Standard blue	03	C5M Keystone blue								
02	C3 Keystone blue	07	White epoxy								

NOTES

1. Only available in the Figure 990 - DIN 25 and 40 (NPS 1 and 1½).
2. Only available in DN 50-150 (NPS 2-6) in the Figure 990 and DIN 50-300 (NPS 2-12) in the 920. Not available in the DN 65 and 125 (NPS 2½ and 5).
3. Not available in DN 25, 40, 65 and 125 (NPS 1, 1½, 2½ and 5).
4. Not available in wafer style body.

Other options are available upon request. Please consult your local sales representative.

Hastelloy® is a registered trademark of Haynes International, Inc.

KEYSTONE FIGURE 990 AND 920 RESILIENT SEATED BUTTERFLY VALVES

This page intentionally left blank.

VCTDS-00027-EN © 2010, 2022 Emerson Electric Co. All rights reserved 03/22. Keystone is a mark owned by one of the companies in the Emerson Automation Solutions business unit of Emerson Electric Co. The Emerson logo is a trademark and service mark of Emerson Electric Co. All other marks are the property of their prospective owners.

The contents of this publication are presented for informational purposes only, and while every effort has been made to ensure their accuracy, they are not to be construed as warranties or guarantees, express or implied, regarding the products or services described herein or their use or applicability. All sales are governed by our terms and conditions, which are available upon request. We reserve the right to modify or improve the designs or specifications of such products at any time without notice.

Emerson Electric Co. does not assume responsibility for the selection, use or maintenance of any product. Responsibility for proper selection, use and maintenance of any Emerson Electric Co. product remains solely with the purchaser.

[Emerson.com/FinalControl](https://www.emerson.com/FinalControl)