

SUSTAINABLE BUSINESS
INNOVATION



on board wireless truck scale



LANX NEXT is the new concept of totally wireless weighing which provides a real time display of the net and gross total weight of the vehicle, directly on Android and iOS devices. Through the LANX NEXT App the entire loading phase is managed easily by Smartphone, with the use of a Hotspot device connected directly to the cigarette lighter socket in the cab. Wi-Fi technology enables communication with the wireless sensors positioned on the vehicle suspensions and with the App of the Android or iOS device. New generation technology, which is quick and easy to install, for an advanced competitive on board weighing system.



Crane Safety Products

ADVANTAGES

- Display of weight always available
- Available for ANDROID and iOS devices
- Wireless on board weighing during loading
- Simple and quick installation
- No fine for overloading
- Reusable system

FUNCTIONS

- Gross and net weight
- Programmable alarm limits for loading/overloading
- Selection vehicle type
- Diagnostics

TECHNICAL DATA

Apple App	iOS 6 or later, iPhone (4S or later), iPod
Android App	Android 4.1 or later, device with WiFi, 3.5" display
	Hotspot
Power supply	10÷30Vdc, cigar lighter plug
Operative frequency	2,4Ghz IEEE 811.15.4
Smartphone power supply socket	USB 5Vdc 500mA
Dimensions	96,1x37,2 mm

VEHICLES WITH AIR SUSPENSIONS

The Wireless digital sensors, which are installed on the tractor rear pneumatic suspensions [1] and on the trailer pneumatic suspensions [2], record the pressure variation due to the weight loaded on the vehicle, by sending data to the LANX NEXT Hotspot device located in the cab. The sensor only needs the pneumatic connection. Being self-powered and with radio transmitter it requires no cables.

Accuracy: **0÷1%**

Technical data	Wireless Sensor 10bar
Power supply	2 x 1.5 V AA batteries
Connection	Wireless
Frequency	2.4 GHz
Range	0-10 bar
Safe overload	20 bar
Working temperature	-40°÷ +85° C
Protection level	IP66
Weight	~0,25Kg

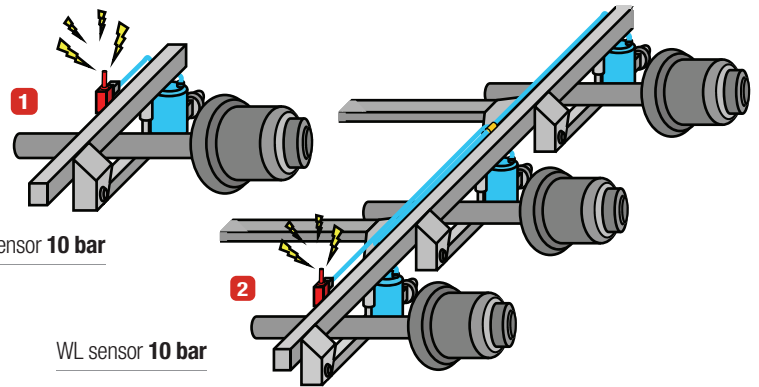
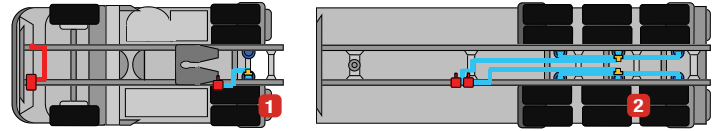

COMPONENTS LIST

LANX NEXT is a new generation on-board weighing system for commercial vehicles, designed to be a “must-have” for truckers who need to know weight loaded at any time and place. New wireless digital sensors make installation simple and quick, combining the advantage of cost reduction and reduced cable maintenance.



Devices



Hotspot with cigarette lighter socket



wireless digital sensor self-powered

