



## ADVANTAGES

- ✓ Real time on board weighing
- ✓ TPMS integration in a single App
- ✓ Available for all type of suspensions
- ✓ Unlimited management of semitrailers/trailers
- ✓ Freedom to choose device size
- ✓ Quick and easy installation
- ✓ Supreme accuracy



T1 is the new concept of on-board weighing and control of tire pressure and temperature for commercial vehicles, semitrailer trucks, rigid trucks with trailers, road train trucks, in one device. The innovative TX4+ bluetooth transmission module allows a direct and constant control of the loaded material and the condition of the tires of your vehicle through an Android App for smartphone or tablet. T1 manages multiple digital sensors suitable for all types of vehicle suspension: pneumatic, hydraulic or mechanical ensuring accuracy and payload control in real time. In addition, thanks to the TPMS wireless sensors, all information relating to the pressure, the temperature and the tire status is displayed in real time on the Android T1 App. All weighing and TPMS data can be transmitted via serial or via can-bus line to the on-board computer or directly in-cloud on external devices, maintaining control and management of productivity and safety of your vehicles.

## FUNCTIONS

- ✓ Visualization of total gross and net weights, axle weights
- ✓ Tire pressure and temperature values
- ✓ Different vehicles layout
- ✓ Overloading alarms
- ✓ TPMS alarms
- ✓ Truck and Trailer ID
- ✓ Tare zeroing

## TX4+ TECHNICAL DATA

Working temperature	-40° ÷ +85° C
Power supply	10÷30 Vdc
Protection level	IP68
Consumption	>0,50 ADC
Dimensions	118x133x36mm
Features	Inverse polarity protection
	Shortcircuit proof
	Bluetooth long range module



Bluetooth paper roll printer >

TPMS sensors ^

Outset tracking data ^

## VEHICLES WITH AIR OR HYDRAULIC SUSPENSIONS

The digital sensors, which are installed on the tractor rear pneumatic suspensions and on the trailer pneumatic/hydraulic suspensions, record the pressure variation due to the weight loaded on the vehicle, by sending data to the TX4+ transmission modules located in the tractor's frame and the trailer's frame. This allows to have a visualization of the total weight and the group of axles. The TPMS external sensors with safety lockers are screwed directly on the tire's valve sending the pressure, the temperature and the tire status of the vehicle directly to the TX4+ transmission module. All informations are displayed in real time on the T1 Android App.

Accuracy: **0 ÷ 1%**

Technical data	Sensor 10 bar	Sensor 160 bar
Range	010 Bar	0160 Bar
Safe overload	150%	150%
Output	0,5 ÷ 4,5V	0,5 ÷ 4,5V
Working temperature	-40° ÷ +100° C	-40° ÷ +100° C
Protection level	IP67	IP67
Weight	38 gr	38 gr

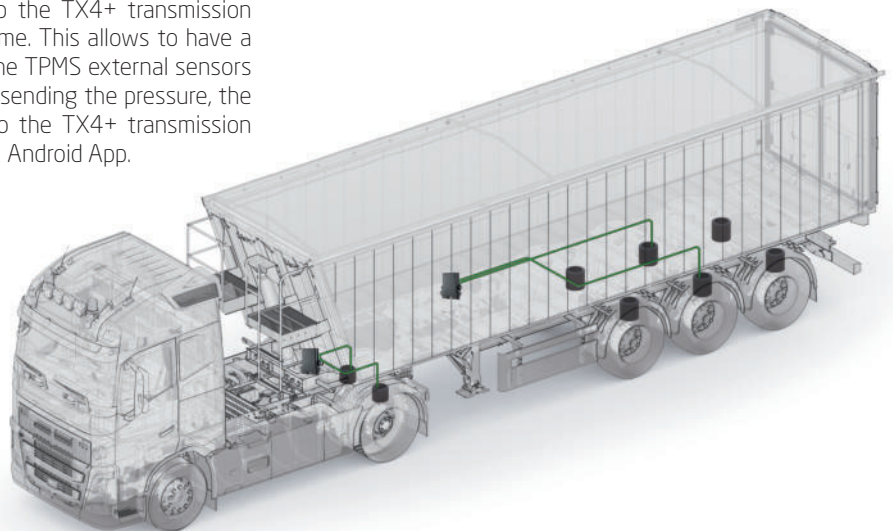

## VEHICLES WITH MIXED SUSPENSIONS

The digital sensors, which are installed on the rigid truck suspensions and on the trailer suspensions, record the angle deformation of the mechanical suspension and the pressure variation due to the weight loaded on the vehicle, by sending data to the TX4+ transmission modules located in the truck's frame and the trailer's frame. This allows to have a visualization of the total weight and also axle by axle. The TPMS external sensors with safety lockers are screwed directly on the tire's valve sending the pressure, the temperature and the tire status of the vehicle directly to the TX4+ transmission module. All informations are displayed in real time on the T1 Android App.

Accuracy TRUCK: **0 ÷ 2%** - Accuracy TRAILER: **0 ÷ 1%**

Technical data	Sensor 10 bar	Height sensor
Range	010 Bar	± 360°
Safe overload	150%	-
Output	0,5 ÷ 4,5V	0,5 ÷ 4,5V
Working temperature	-40° ÷ +100° C	-40° ÷ +125° C
Protection level	IP67	IP67
Weight	38 gr	20 gr

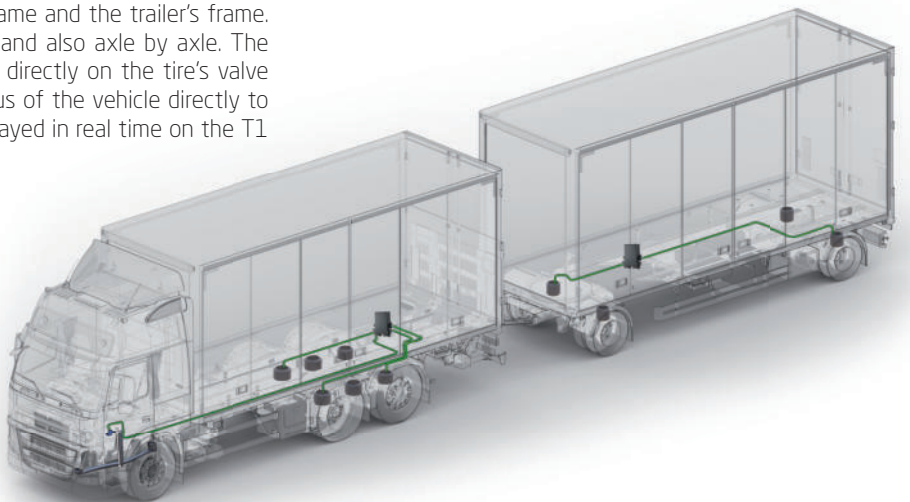

## TX4+ TRANSMISSION MODULE

- ✓ Cloud data storage
- ✓ Bluetooth printer
- ✓ Dashboard
- ✓ Integrated data management
- ✓ Customized app



## OTD - OUTSET TRACKING DATA

- ✓ Weighing data management
- ✓ TPMS data management
- ✓ Anomaly detection
- ✓ GPS tracking
- ✓ 24/7 monitoring
- ✓ Cloud data collection

