

A F P

CPCD15-35
FORKLIFT



A F P AFQUIP AFRICA

LIUGONG

TOUGH WORLD. TOUGH EQUIPMENT.

 www.afquip.com

CPCD15-35 FORKLIFT

MAXIMIZE YOUR RETURN ON INVESTMENT

LiuGong's **customer-driven** design and **quality-focused** engineering creates lasting value that will deliver to your bottom line.

DEPENDABLE POWER

Unmatched performance driven by the World-Class Engine.



ERGONOMIC

Widen operating space and reasonable design can give the operator better experience.



COMFORTABLE

The full hydraulic steering system allows for smooth steering in an ergonomic seating posture, hence improved operator's comfort.

HIGH EFFICIENCY

Newly optimized hydraulic system provides excellent lifting speed, assisting you to finish work efficiently and safely.

GOOD VIEW

The mast and overhead guard are designed for wider view, as well as operator's comfort and safety.



MAINTAINING

The engine hood hood with big angle for easy to maintain.



PARTS

Using genuine LiuGong parts is key to keeping your costs low and your machine in top working order. Our extensive support network is always there when you need it, to maximize your business profitability.

AFTER SALES SERVICE

As a customer of LiuGong you can feel confident that our dealers and regional offices will be there to support you with training, service and maintenance needed throughout the life of your machine.

SPECIFICATION

General	Model	1			CPCD15	CPCD15	
	Power Type	2			Diesel	GAS / LPG	
	Base Capacity	3	@rated load center	kg	1,500	1,500	
	Load Center	4		mm	500	500	
	Service Weight	5	unloaded	kg	2,700	2,700	
Weights	Axle Load	6	loaded / unloaded, front	kg	3,680 / 1,030	3,680 / 1,030	
		7	loaded / unloaded, rear	kg	520 / 1,670	520 / 1,670	
Tires	Tire Type	8			Pneumatic	Pneumatic	
	Wheels	9	front / rear		2 / 2	2 / 2	
	Wheelbase	10		mm	1,430	1,430	
	Tire Size	11	front		6.50-10-10PR	6.50-10-10PR	
		12	rear		5.00-8-8PR	5.00-8-8PR	
	Tread Width	13	front / rear		890 / 910	890 / 910	
Mast	Max. Fork Height	14	with std 2-stage mast	mm	3,000	3,000	
	Free lift	15	with std 2-stage mast	mm	130	130	
	Height, Upright Lowered	16	with std 2-stage mast	mm	2,040	2,040	
	Height, Upright Extended	17	with std 2-stage mast	mm	4,030	4,030	
	Mast Tilt, Fwd/Back	18	with std 2-stage mast	deg	6° / 12°	6° / 12°	
	Carriage	19	width	mm	970	970	
	Fork Spread	20	minimum / maximum	mm	202 / 970	202 / 970	
	Fork Dimensions	21	T x W x L	mm	35x 100 x 920	35x 100 x 920	
Chassis	Length to Fork Face	22	with std 2-stage mast	mm	2,330	2,330	
	Overall Width	23		mm	1,080	1,080	
	Overhead Guard Height	24		mm	2,070	2,070	
	Turning Radius	25	minimum outside	mm	1,950	1,950	
	Fork Overhang	26	with std 2-stage mast	mm	433	433	
	Right Angle Stack	27	add load length and clearance	mm	3,490	3,490	
	Ground Clearance	28	minimum loaded	mm	80	80	
	29	center of wheelbase	mm	120	120		
Performance	Travel Speed	30	loaded / unloaded	km/h	15 / 15	15 / 15	
	Lift Speed	31	loaded / unloaded	m/s	0.53 / 0.55	0.53 / 0.55	
	Lower Speed	32	loaded / unloaded	m/s	0.50 / 0.45	0.50 / 0.45	
	Max. Drawbar Pull	33	loaded	kg	1,700	1,700	
	Max. Gradeability	34	loaded / unloaded	%	20 / 20	20 / 20	
Systems	Brakes	35	service		Foot / Hyd	Foot / Hyd	
		36	parking		Hand / Mech	Hand / Mech	
		37	manufacturer		Xinchai	Yanmar	
	Engine	38	model			NC485BPG-2	4TNE92-HRJ
		39	emission compliance			CHN Stage II	EU Stage IIIA
		40	cylinders			4	4
		41	displacement	liters		2.27	2.66
		42	rated power	kW/rpm		30 / 2,600	32.8 / 2,450
		43	Max. torque	N · m/rpm		131 / 1,900	140 / 1,700

SPECIFICATION

General	Model	1			CPCD18	CPCD18	
	Power Type	2			Diesel	GAS/LPG	
	Base Capacity	3	@rated load center	kg	1,800	1,800	
	Load Center	4		mm	500	500	
	Service Weight	5	unloaded	kg	2,920	2,920	
Weights	Axle Load	6	loaded / unloaded, front	kg	4,130 / 1,000	4,130 / 1,000	
		7	loaded / unloaded, rear	kg	590 / 1,920	590 / 1,920	
Tires	Tire Type	8			Pneumatic	Pneumatic	
	Wheels	9	front / rear		2 / 2	2 / 2	
	Wheelbase	10		mm	1,430	1,430	
	Tire Size	11	front		6.50-10-10PR	6.50-10-10PR	
		12	rear		5.00-8-8PR	5.00-8-8PR	
	Tread Width	13	front / rear		890 / 910	890 / 910	
Mast	Max. Fork Height	14	with std 2-stage mast	mm	3,000	3,000	
	Free lift	15	with std 2-stage mast	mm	130	130	
	Height, Upright Lowered	16	with std 2-stage mast	mm	2,040	2,040	
	Height, Upright Extended	17	with std 2-stage mast	mm	4,030	4,030	
	Mast Tilt, Fwd/Back	18	with std 2-stage mast	deg	6° / 12°	6° / 12°	
	Carriage	19	width	mm	970	970	
	Fork Spread	20	minimum / maximum	mm	202 / 970	202 / 970	
	Fork Dimensions	21	T x W x L	mm	35x 100 x 920	35x 100 x 920	
Chassis	Length to Fork Face	22	with std 2-stage mast	mm	2,370	2,370	
	Overall Width	23		mm	1,080	1,080	
	Overhead Guard Height	24		mm	2,070	2,070	
	Turning Radius	25	minimum outside	mm	1,990	1,990	
	Fork Overhang	26	with std 2-stage mast	mm	433	433	
	Right Angle Stack	27	add load length and clearance	mm	3,550	3,550	
	Ground Clearance	28	minimum loaded	mm	80	80	
	29	center of wheelbase	mm	120	120		
Performance	Travel Speed	30	loaded / unloaded	km/h	15 / 15	15 / 15	
	Lift Speed	31	loaded / unloaded	m/s	0.53 / 0.55	0.53 / 0.55	
	Lower Speed	32	loaded / unloaded	m/s	0.50 / 0.45	0.50 / 0.45	
	Max. Drawbar Pull	33	loaded	kg	1,700	1,700	
	Max. Gradeability	34	loaded / unloaded	%	20 / 20	20 / 20	
Systems	Brakes	35	service		Foot / Hyd	Foot / Hyd	
		36	parking		Hand / Mech	Hand / Mech	
		37	manufacturer		Xinchai	Yanmar	
	Engine	38	model			NC485BPG-2	4TNE92-HRJ
		39	emission compliance			CHN Stage II	EU Stage IIIA
		40	cylinders			4	4
		41	displacement	liters		2.27	2.66
		42	rated power	kW/rpm		30 / 2,600	32.8 / 2,450
		43	Max. torque	N · m/rpm		131 / 1,900	140 / 1,700

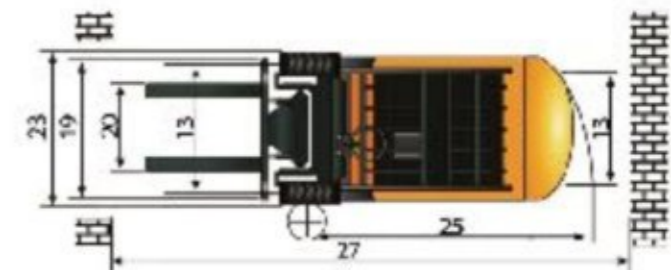
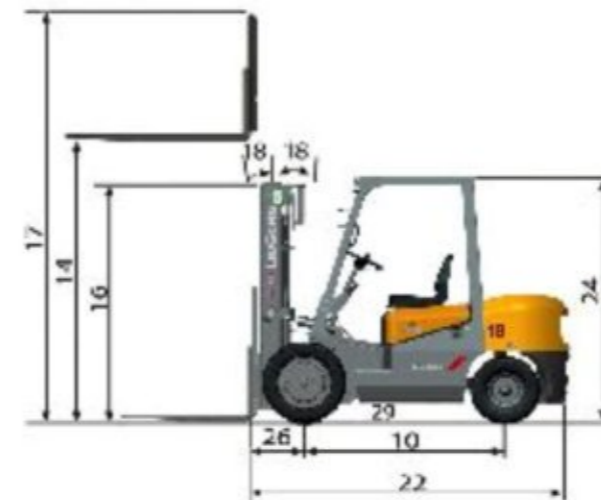
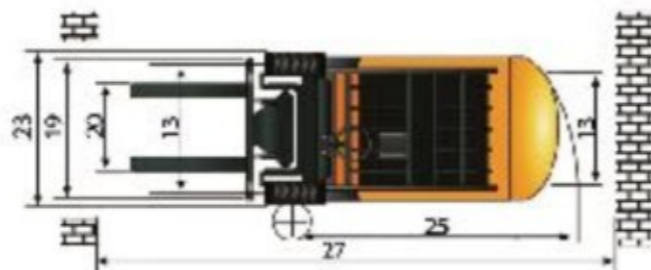
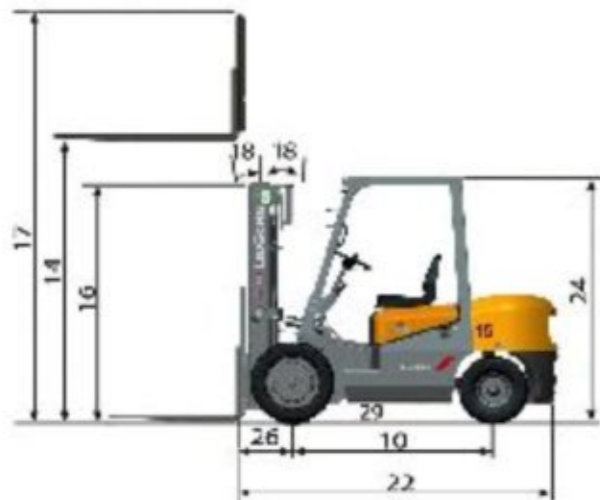

SPECIFICATION

General	Model	1			CPCD20	CPCD20	
	Power Type	2			Diesel	GAS / LPG	
	Base Capacity	3	@rated load center	kg	2,000	2,000	
	Load Center	4		mm	500	500	
Weights	Service Weight	5	unloaded	kg	3,300	3,300	
	Axle Load	6	loaded / unloaded, front	kg	4,640 / 1,460	4,640 / 1,460	
	7	loaded / unloaded, rear	kg	660 / 1,840	660 / 1,840		
Tires	Tire Type	8			Pneumatic	Pneumatic	
	Wheels	9	front / rear		2 / 2	2 / 2	
	Wheelbase	10		mm	1,650	1,650	
	Tire Size	11	front		7.00-12-12PR	7.00-12-12PR	
	12	rear		6.00-9-10PR	6.00-9-10PR		
Mast	Tread Width	13	front / rear		970 / 980	970 / 980	
	Max. Fork Height	14	with std 2-stage mast	mm	3,000	3,000	
	Free lift	15	with std 2-stage mast	mm	145	145	
	Height, Upright Lowered	16	with std 2-stage mast	mm	2,070	2,070	
	Height, Upright Extended	17	with std 2-stage mast	mm	4,025	4,025	
	Mast Tilt, Fwd/Back	18	with std 2-stage mast	deg	6° / 12°	6° / 12°	
	Carriage	19	width	mm	1,040	1,040	
	Fork Spread	20	minimum / maximum	mm	222 / 1,010	222 / 1,010	
	Fork Dimensions	21	T x W x L	mm	45 x 100 x 1,070	45 x 100 x 1,070	
	Chassis	Length to Fork Face	22	with std 2-stage mast	mm	2,550	2,550
Overall Width		23		mm	1,150	1,150	
Overhead Guard Height		24		mm	2,100	2,100	
Turning Radius		25	minimum outside	mm	2,190	2,190	
Fork Overhang		26	with std 2-stage mast	mm	458	458	
Right Angle Stack		27	add load length and clearance	mm	3,900	3,900	
Ground Clearance		28	minimum loaded	mm	120	120	
		29	center of wheelbase	mm	140	140	
Performance		Travel Speed	30	loaded / unloaded	km/h	19 / 20	19 / 20
	Lift Speed	31	loaded / unloaded	m/s	0.46 / 0.50	0.46 / 0.50	
	Lower Speed	32	loaded / unloaded	m/s	0.55 / 0.40	0.55 / 0.40	
	Max. Drawbar Pull	33	loaded	kg	1,600	1,600	
	Max. Gradeability	34	loaded / unloaded	%	18 / 20	18 / 20	
Systems	Brakes	35	service		Foot / Hyd	Foot / Hyd	
		36	parking		Hand / Mech	Hand / Mech	
		37	manufacturer		Xinchai	Isuzu	
	Engine	38	model		C490BPG	C240-NBKEG	4TNE92-HRJ
		39	emission compliance		CHN Stage II	EU Stage IIIA	EU Stage IIIA
		40	cylinders		4	4	4
		41	displacement	liters	2.67	2.37	2.66
		42	rated power	kW/rpm	40 / 2,650	35.4 / 2,500	32.8 / 2,450
		43	Max. torque	N · m/rpm	160 / 1,900	137.7 / 1,800	140 / 1,700

SPECIFICATION

General	Model	1			CPCD25	CPCD25	
	Power Type	2			Diesel	GAS / LPG	
	Base Capacity	3	@rated load center	kg	2,500	2,500	
	Load Center	4		mm	500	500	
Weights	Service Weight	5	unloaded	kg	3,500	3,500	
	Axle Load	6	loaded / unloaded, front	kg	5,390 / 1,430	5,390 / 1,430	
	7	loaded / unloaded, rear	kg	710 / 2,170	710 / 2,170		
Tires	Tire Type	8			Pneumatic	Pneumatic	
	Wheels	9	front / rear		2 / 2	2 / 2	
	Wheelbase	10		mm	1,650	1,650	
	Tire Size	11	front		7.00-12-12PR	7.00-12-12PR	
	12	rear		6.00-9-10PR	6.00-9-10PR		
Mast	Tread Width	13	front / rear		970 / 980	970 / 980	
	Max. Fork Height	14	with std 2-stage mast	mm	3,000	3,000	
	Free lift	15	with std 2-stage mast	mm	145	145	
	Height, Upright Lowered	16	with std 2-stage mast	mm	2,070	2,070	
	Height, Upright Extended	17	with std 2-stage mast	mm	4,025	4,025	
	Mast Tilt, Fwd/Back	18	with std 2-stage mast	deg	6° / 12°	6° / 12°	
	Carriage	19	width	mm	1,040	1,040	
	Fork Spread	20	minimum / maximum	mm	222 / 1,010	222 / 1,010	
	Fork Dimensions	21	T x W x L	mm	45 x 100 x 1,070	45 x 100 x 1,070	
	Chassis	Length to Fork Face	22	with std 2-stage mast	mm	2,630	2,630
Overall Width		23		mm	1,150	1,150	
Overhead Guard Height		24		mm	2,100	2,100	
Turning Radius		25	minimum outside	mm	2,190	2,190	
Fork Overhang		26	with std 2-stage mast	mm	458	458	
Right Angle Stack		27	add load length and clearance	mm	3,950	3,950	
Ground Clearance		28	minimum loaded	mm	120	120	
		29	center of wheelbase	mm	140	140	
Performance		Travel Speed	30	loaded / unloaded	km/h	19 / 20	19 / 20
	Lift Speed	31	loaded / unloaded	m/s	0.46 / 0.50	0.46 / 0.50	
	Lower Speed	32	loaded / unloaded	m/s	0.55 / 0.40	0.55 / 0.40	
	Max. Drawbar Pull	33	loaded	kg	1,600	1,600	
	Max. Gradeability	34	loaded / unloaded	%	18 / 20	18 / 20	
Systems	Brakes	35	service		Foot / Hyd	Foot / Hyd	
		36	parking		Hand / Mech	Hand / Mech	
		37	manufacturer		Xinchai	Isuzu	
	Engine	38	model		C490BPG	C240-NBKEG	4TNE92-HRJ
		39	emission compliance		CHN Stage II	EU Stage IIIA	EU Stage IIIA
		40	cylinders		4	4	4
		41	displacement	liters	2.67	2.37	2.66
		42	rated power	kW/rpm	40 / 2,650	35.4 / 2,500	32.8 / 2,450
		43	Max. torque	N · m/rpm	160 / 1,900	137.7 / 1,800	140 / 1,700

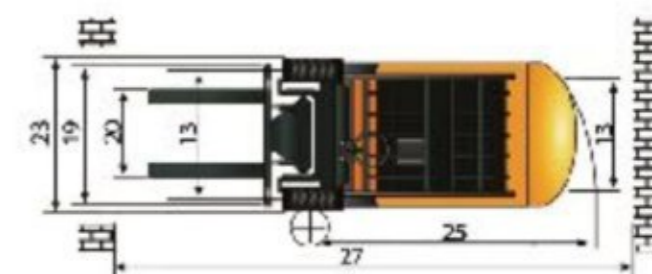
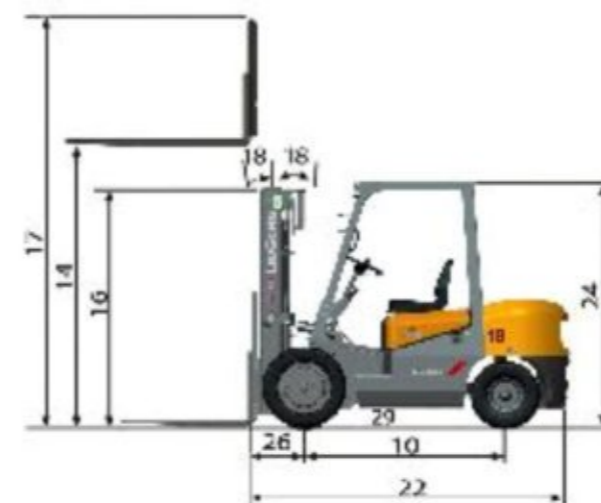
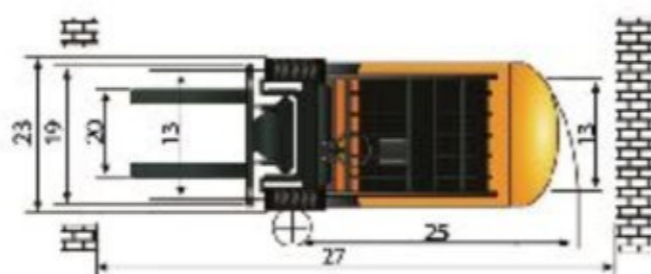
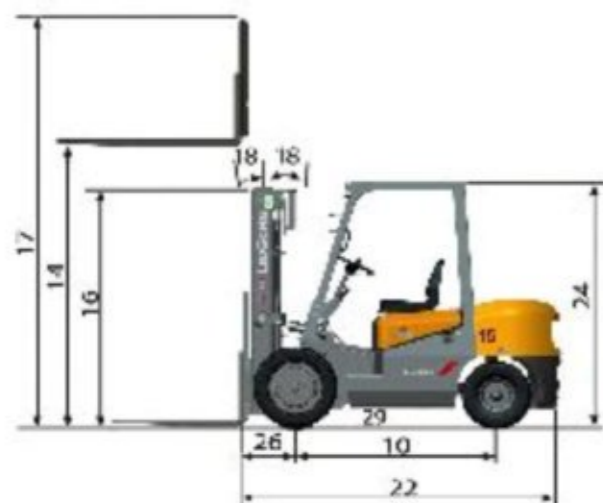

SPECIFICATION

General	Model	1			CPCD30	CPCD30	
	Power Type	2			Diesel	Gas / LPG	
Base Capacity	3	@rated load center	kg	3,000	3,000		
Load Center	4		mm	500	500		
Weights	Service Weight	5	unloaded	kg	4,230	4,230	
	Axle Load	6	loaded / unloaded, front	kg	6,400 / 1,650	6,400 / 1,650	
		7	loaded / unloaded, rear	kg	830 / 2,580	830 / 2,580	
Tires	Tire Type	8			Pneumatic	Pneumatic	
	Wheels	9	front / rear		2 / 2	2 / 2	
	Wheelbase	10		mm	1,700	1,700	
	Tire Size	11	front		28x9-15-14PR	28x9-15-14PR	
		12	rear		6.50-10-10PR	6.50-10-10PR	
Mast	Tread Width	13	front / rear		1,000 / 980	1,000 / 980	
	Max. Fork Height	14	with std 2-stage mast	mm	3,000	3,000	
	Free lift	15	with std 2-stage mast	mm	145	145	
	Height, Upright Lowered	16	with std 2-stage mast	mm	2,080	2,080	
	Height, Upright Extended	17	with std 2-stage mast	mm	4,146	4,146	
	Mast Tilt, Fwd/Back	18	with std 2-stage mast	deg	6° / 12°	6° / 12°	
	Carriage	19	width	mm	1,100	1,100	
	Fork Spread	20	minimum / maximum	mm	272 / 1,072	272 / 1,072	
	Fork Dimensions	21	T x W x L	mm	45 x 122 x 1,070	45 x 122 x 1,070	
	Chassis	Length to Fork Face	22	with std 2-stage mast	mm	2,705	2,705
Overall Width		23		mm	1,225	1,225	
Overhead Guard Height		24		mm	2,170	2,170	
Turning Radius		25	minimum outside	mm	2,400	2,400	
Fork Overhang		26	with std 2-stage mast	mm	471	471	
Right Angle Stack		27	add load length and clearance	mm	4,141	4,141	
Ground Clearance		28	minimum loaded	mm	135	135	
		29	center of wheelbase	mm	140	140	
Performance	Travel Speed	30	loaded / unloaded	km/h	18.5 / 19	18.5 / 19	
	Lift Speed	31	loaded / unloaded	m/s	0.43 / 0.45	0.43 / 0.45	
	Lower Speed	32	loaded / unloaded	m/s	0.46 / 0.40	0.46 / 0.40	
	Max. Drawbar Pull	33	loaded	kg	1,650	2,000	
	Max. Gradeability	34	loaded / unloaded	%	18 / 20	20 / 20	
Systems	Brakes	35	service		Foot / Hyd	Foot / Hyd	
		36	parking		Hand / Mech	Hand / Mech	
		37	manufacturer		Xinchai	Isuzu	Yanmar
	Engine	38	model		C490BPG	C240-NBKEG	4TNE98-BQFLC
		39	emission compliance		CHN Stage II	EU Stage IIIA	EU Stage IIIA
		40	cylinders		4	4	4
		41	displacement	liters	2.67	2.37	3.32
		42	rated power	kW/rpm	40 / 2,650	35.4 / 2,500	42.1 / 2,300
		43	Max. torque	N · m/rpm	160 / 1,900	137.7 / 1,800	196.3 / 1,700

SPECIFICATION

General	Model	1			CPCD35	CPCD35	
	Power Type	2			Diesel	Gas / LPG	
Base Capacity	3	@rated load center	kg	3,500	3,500		
Load Center	4		mm	500	500		
Weights	Service Weight	5	unloaded	kg	4,430	4,430	
	Axle Load	6	loaded / unloaded, front	kg	7,080 / 1,600	7,080 / 1,600	
		7	loaded / unloaded, rear	kg	850 / 2,830	850 / 2,830	
Tires	Tire Type	8			Pneumatic	Pneumatic	
	Wheels	9	front / rear		2 / 2	2 / 2	
	Wheelbase	10		mm	1,700	1,700	
	Tire Size	11	front		28x9-15-14PR	28x9-15-14PR	
		12	rear		6.50-10-10PR	6.50-10-10PR	
Mast	Tread Width	13	front / rear		1,000 / 980	1,000 / 980	
	Max. Fork Height	14	with std 2-stage mast	mm	3,000	3,000	
	Free lift	15	with std 2-stage mast	mm	145	145	
	Height, Upright Lowered	16	with std 2-stage mast	mm	2,080	2,080	
	Height, Upright Extended	17	with std 2-stage mast	mm	4,146	4,146	
	Mast Tilt, Fwd/Back	18	with std 2-stage mast	deg	6° / 12°	6° / 12°	
	Carriage	19	width	mm	1,100	1,100	
	Fork Spread	20	minimum / maximum	mm	272 / 1,072	272 / 1,072	
	Fork Dimensions	21	T x W x L	mm	50 x 122 x 1,070	50 x 122 x 1,070	
	Chassis	Length to Fork Face	22	with std 2-stage mast	mm	2,743	2,743
Overall Width		23		mm	1,225	1,225	
Overhead Guard Height		24		mm	2,170	2,170	
Turning Radius		25	minimum outside	mm	2,435	2,435	
Fork Overhang		26	with std 2-stage mast	mm	476	476	
Right Angle Stack		27	add load length and clearance	mm	4,176	4,176	
Ground Clearance		28	minimum loaded	mm	135	135	
		29	center of wheelbase	mm	140	140	
Performance	Travel Speed	30	loaded / unloaded	km/h	18.5 / 19	18.5 / 19	
	Lift Speed	31	loaded / unloaded	m/s	0.43 / 0.45	0.43 / 0.45	
	Lower Speed	32	loaded / unloaded	m/s	0.46 / 0.40	0.46 / 0.40	
	Max. Drawbar Pull	33	loaded	kg	1,650	2,000	
	Max. Gradeability	34	loaded / unloaded	%	18 / 20	20 / 20	
Systems	Brakes	35	service		Foot / Hyd	Foot / Hyd	
		36	parking		Hand / Mech	Hand / Mech	
		37	manufacturer		Xinchai	Isuzu	Yanmar
	Engine	38	model		C490BPG	C240-NBKEG	4TNE98-BQFLC
		39	emission compliance		CHN Stage II	EU Stage IIIA	EU Stage IIIA
		40	cylinders		4	4	4
		41	displacement	liters	2.67	2.37	3.32
		42	rated power	kW/rpm	40 / 2,650	35.4 / 2,500	42.1 / 2,300
		43	Max. torque	N · m/rpm	160 / 1,900	137.7 / 1,800	196.3 / 1,700

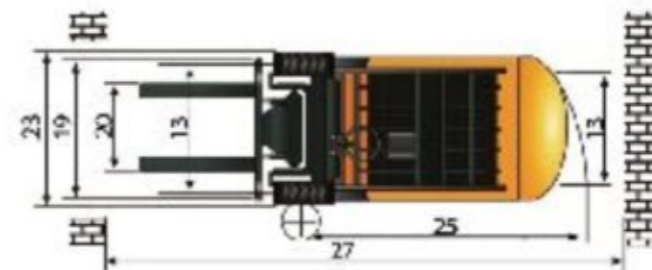
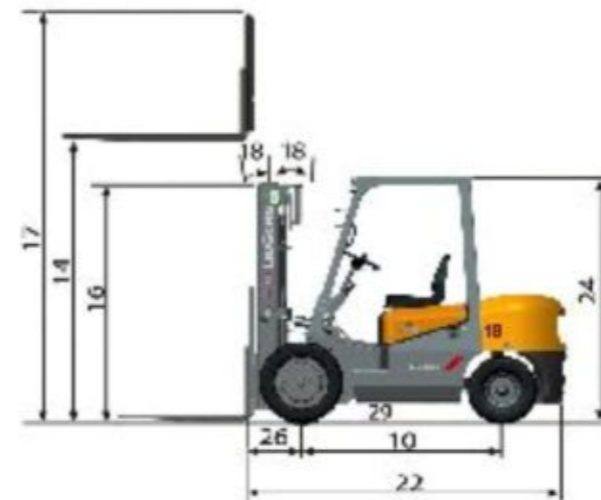
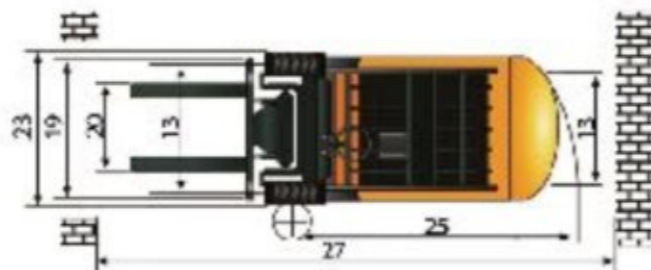
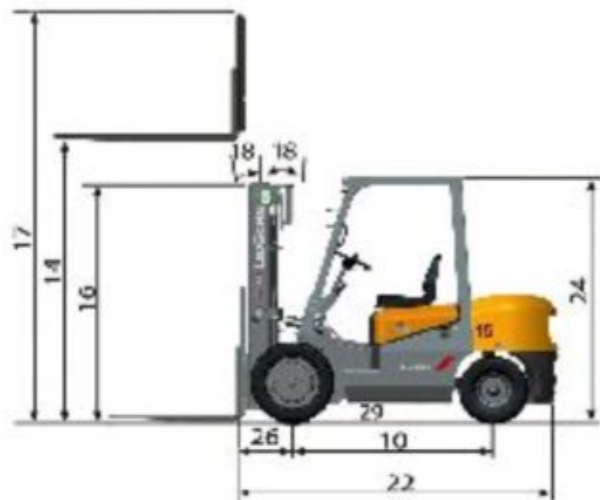

CAPACITY

Mast type	Maximum Fork Height (MFH)	Mast Overall Lowered Height (OAL)	Freee Lift with Load Backrest	Mast Tilt Angle (F/B)	Rated Load Capacity				Total Weight with Standard Forks	
					With Standard Forks		With Sideshifter			
					CPCD15	CPCD18	CPCD15	CPCD18	CPCD15	CPCD18
	mm	mm	mm	degree	kg @ (500mm LC)		kg @ (500mm LC)		Kg	
Standard 2-Stage	3000	2030	135	6 / 12	1500	1800	1400	1700	2700	2920
	3300	2180	135	6 / 12	1500	1800	1400	1700	2715	2935
	3500	2280	135	6 / 12	1500	1800	1400	1700	2725	2945
	4000	2580	135	6 / 6	1500	1800	1350	1650	2756	2976
	4500	2830	135	6 / 6	1370	1670	1200	1500	2781	3001
5000	3130	135	3 / 6	1100	1400	1000	1300	2806	3026	

Mast type	Maximum Fork Height (MFH)	Mast Overall Lowered Height (OAL)	Freee Lift with Load Backrest*	Mast Tilt Angle (F/B)	Rated Load Capacity				Total Weight with Standard Forks	
					With Standard Forks		With Sideshifter			
					CPCD15	CPCD18	CPCD15	CPCD18	CPCD15	CPCD18
	mm	mm	mm	degree	kg @ (500mm LC)		kg @ (500mm LC)		Kg	
Full Free 2-Stage	3000	2030	1095	6 / 12	1500	1800	1400	1700	2720	2940

Mast type	Maximum Fork Height (MFH)	Mast Overall Lowered Height (OAL)	Freee Lift with Load Backrest*	Mast Tilt Angle (F/B)	Rated Load Capacity				Total Weight with Standard Forks	
					With Standard Forks		With Sideshifter			
					CPCD15	CPCD18	CPCD15	CPCD18	CPCD15	CPCD18
	mm	mm	mm	degree	kg @ (500mm LC)		kg @ (500mm LC)		Kg	
Full Free 3-Stage	3600	1730	790	6 / 6	1400	1700	1300	1600	3095	3725
	4500	2030	1095	6 / 6	1300	1600	1200	1500	3170	3760
	4800	2135	1200	6 / 6	1200	1500	1100	1400	3200	3780

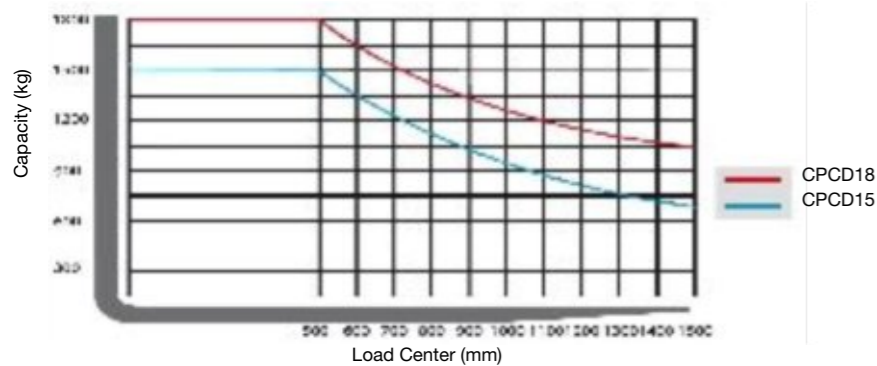

Note:
Vertical axle stands for load capacity while horizontal axle stands for load center, Load center is the distance counted from the front of the fork.,The base point of the standard load is the center point of the cubic with the same 1000mm dimension in length, width and height. The load capacity should be down if mast tilt forward or using non-standard forks of loading goods with extra width. Please realize the different load capacity between different load centers according to load chart.

CAPACITY

Mast type	Maximum Fork Height (MFH)	Mast Overall Lowered Height (OAL)	Freee Lift with Load Backrest	Mast Tilt Angle (F/B)	Rated Load Capacity				Total Weight with Standard Forks	
					With Standard Forks		With Sideshifter			
					CPCD20	CPCD25	CPCD20	CPCD25	CPCD20	CPCD25
	mm	mm	mm	degree	kg @ (500mm LC)		kg @ (500mm LC)		Kg	
Standard 2-Stage	3000	2080	120	6 / 12	2000	2500	1850	2350	3300	3500
	3300	2190	120	6 / 12	2000	2500	1850	2350	3321	3521
	3500	2230	120	6 / 12	2000	2500	1850	2350	3335	3535
	4000	2630	120	6 / 6	2000	2500	1750	2300	3446	3646
	4500	2880	120	6 / 6	1920	2420	1650	2150	3551	3751
5000	3130	120	3 / 6	1660	2160	1450	2050	3655	3855	

Mast type	Maximum Fork Height (MFH)	Mast Overall Lowered Height (OAL)	Freee Lift with Load Backrest*	Mast Tilt Angle (F/B)	Rated Load Capacity				Total Weight with Standard Forks	
					With Standard Forks		With Sideshifter			
					CPCD20	CPCD25	CPCD20	CPCD25	CPCD20	CPCD25
	mm	mm	mm	degree	kg @ (500mm LC)		kg @ (500mm LC)		Kg	
Full Free 2-Stage	2700	1930	830	6 / 12	2000	2500	1850	2350	3330	3530
	3000	2080	980	6 / 12	2000	2500	1850	2350	3351	3551

Mast type	Maximum Fork Height (MFH)	Mast Overall Lowered Height (OAL)	Freee Lift with Load Backrest*	Mast Tilt Angle (F/B)	Rated Load Capacity				Total Weight with Standard Forks	
					With Standard Forks		With Sideshifter			
					CPCD20	CPCD25	CPCD20	CPCD25	CPCD20	CPCD25
	mm	mm	mm	degree	kg @ (500mm LC)		kg @ (500mm LC)		Kg	
Full Free 3-Stage	3600	1820	660	6 / 6	1800	2300	1650	2150	3525	3725
	4000	1950	710	6 / 6	1800	2300	1650	2150	3560	3760
	4300	2050	760	6 / 6	1750	2200	1600	2050	3580	3780
	4500	2120	770	6 / 6	1700	2100	1550	1950	3600	3800
	4700	2190	820	6 / 6	1500	1600	1350	1600	3620	3820
	5000	2290	870	3 / 6	1500	1600	1250	1450	3770	3970

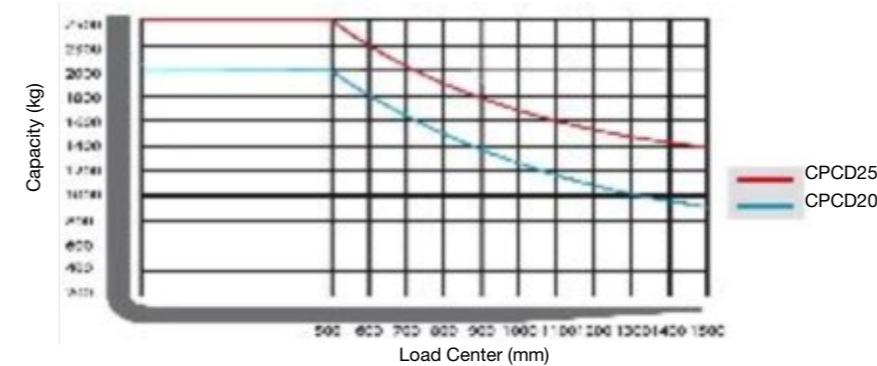

Note:
Vertical axle stands for load capacity while horizontal axle stands for load center, Load center is the distance counted from the front of the fork.,The base point of the standard load is the center point of the cubic with the same 1000mm dimension in length, width and height. The load capacity should be down if mast tilt forward or using non-standard forks of loading goods with extra width. Please realize the different load capacity between different load centers according to load chart.

CAPACITY

Mast type	Maximum Fork Height (MFH)	Mast Overall Lowered Height (OAL)	Freee Lift with Load Backrest	Mast Tilt Angle (F/B)	Rated Load Capacity				Total Weight with Standard Forks	
					With Standard Forks		With Sideshifter			
					mm	mm	mm	degree	CPCD30	CPCD35
Standard 2-Stage					kg @ (500mm LC)		kg @ (500mm LC)		Kg	
	3000	2120	145	6 / 12	3000	3500	2750	3250	4230	4430
	3300	2270	145	6 / 12	3000	3450	2750	3200	4255	4456
	3500	2370	145	6 / 12	2750	3250	2600	3100	4280	4479
	4000	2670	145	6 / 6	2600	3100	2500	3000	4370	4569
	4500	2920	145	6 / 6	2400	2900	2300	2800	4415	4613
	5000	3220	145	3 / 6	2200	2700	2100	2600	4460	4657
	5500	3670	145	3 / 6	2100	2600	2000	2500	4510	4710
6000	4020	145	3 / 6	2000	2500	1900	2400	4555	4755	

Mast type	Maximum Fork Height (MFH)	Mast Overall Lowered Height (OAL)	Freee Lift with Load Backrest*	Mast Tilt Angle (F/B)	Rated Load Capacity				Total Weight with Standard Forks	
					With Standard Forks		With Sideshifter			
					mm	mm	mm	degree	CPCD30	CPCD35
Full Free 2-Stage					kg @ (500mm LC)		kg @ (500mm LC)		Kg	
	3000	2120	964	6 / 12	3000	3500	2750	3250	4270	4470
	3500	2370	1214	6 / 12	2750	3250	2600	3100	4320	4519

Mast type	Maximum Fork Height (MFH)	Mast Overall Lowered Height (OAL)	Freee Lift with Load Backrest*	Mast Tilt Angle (F/B)	Rated Load Capacity				Total Weight with Standard Forks	
					With Standard Forks		With Sideshifter			
					mm	mm	mm	degree	CPCD30	CPCD35
Full Free 3-Stage					kg @ (500mm LC)		kg @ (500mm LC)		Kg	
	3600	1815	659	6 / 6	2650	3150	2450	2950	4365	4655
	4000	1950	794	6 / 6	2450	2950	2250	2750	4400	4690
	4500	2120	964	6 / 6	2250	2750	2050	2550	4440	4730
	4700	2190	1034	6 / 6	2100	2600	1950	2350	4460	4750
	5000	2295	1134	3 / 6	1900	2400	1600	2100	4610	4900
	5500	2450	1304	3 / 6	1700	2200	1450	1950	4790	5080
	6000	2630	1474	3 / 6	1500	2000	1300	1800	4840	5130
7000	3465	2245	3 / 3	-	1100	-	950	-	5190	

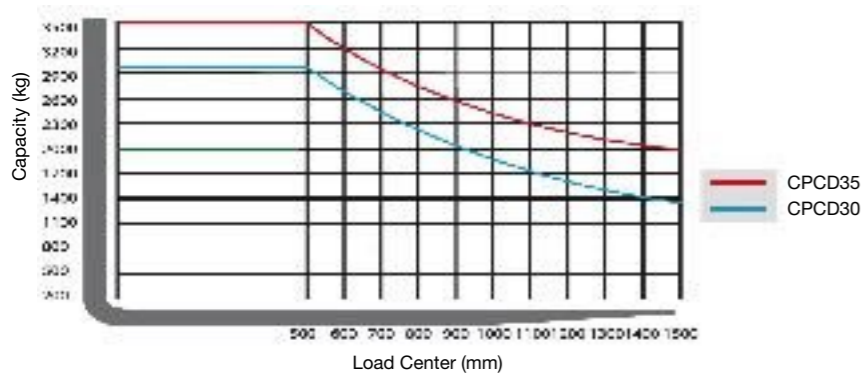

Note:
Vertical axle stands for load capacity while horizontal axle stands for load center, Load center is the distance counted from the front of the fork. The base point of the standard load is the center point of the cubic with the same 1000mm dimension in length, width and height. The load capacity should be down if mast tilt forward or using non-standard forks of loading goods with extra width. Please realize the different load capacity between different load centers according to load chart.

STANDARD CONFIGURATION

POWER SYSTEM

- Xinchai NC485BPG diesel engine (CPCD15-18)
- Xinchai C490BPG diesel engine (CPCD20-35)
- One-speed automatic transmission
- High strength drive axle
- Heavy duty steering axle
- Air filter with dual-elements
- Fuel system pre-filter
- Radiator
- Low exhaust

HYDRAULIC SYSTEM

- 2-funtion hydraulic valve
- Hydrostatic steering
- Oil filter for intake and return
- Hydraulic oil radiator (CPCD30-35 only)

ELECTRIC SYSTEM

- 1 batteries
- Front flood lights
- Front steering lights
- Rear combination lights
- Buzzer for back off

UNDERCARRIAGE

- High strength frame
- 1 piece counterweight
- Tow pin
- Air filled pneumatic drive tires
- Air filled pneumatic steer tires

MAST

- 3.0M Standard 2-stage mast
- 970mm Wide Class II carriage (CPCD15-18)
- 1040mm Wide Class II carriage (CPCD20-25)
- 1100mm Wide Class III carriage (CPCD30-35)
- Load backrest
- 920mm long Class II pallet forks (CPCD15-18)
- 1070mm long Class II pallet forks (CPCD20-25)
- 1070mm long Class III pallet forks (CPCD30-35)

OPERATOR STATION

- Overhead guard
- Locks for engine hood
- Vinyl cushion seat with seat belt
- Ignition lock
- Display with alarms, fuel rate, water temperature, working hour
- Tilt steering column
- Inching, brake and accelerator pedals
- Hand parking
- Floor mat

OPTIONAL CONFIGURATION

POWER SYSTEM

- Xinchai A498BPG or A498BT1 diesel engine (CPCD20-35)
- Isuzu C240 diesel engine (CPCD20-35)
- Isuzu 4JG2 diesel engine (CPCD30-35)
- Yanmar 4TNE92 diesel engine (CPCD15-25)
- Yanmar 4TNE98 diesel engine (CPCD30-35)
- Cummins QSF 2.8 diesel engine (CPCD30-35)
- Nissan K21 engine (Gas/LPG) (CPCD15-18)
- Nissan K25 engine (Gas/LPG) (CPCD20-35)
- Elevated air pre-cleaner
- 2nd refined air filter
- Middle exhaust
- Vertical exhaust

HYDRAULIC SYSTEM

- 3-funtion hydraulic valve
- 4-funtion hydraulic valve

ELECTRIC SYSTEM

- Rear working light
- Amber warning light
- License plate light

UNDERCARRIAGE

- Solid pneumatic drive tires
- Solid pneumatic steer tires

MAST

- Full free 2-stage mast
- Full free 3-stage mast
- Longer Class II or III pallet forks

OPERATION STATION

- Enclosed cabin
- Heater for cabin
- Operator fan
- Cup holder
- Fire extinguisher
- Expansion tank
- Anti-corrosion lifting and tilting cylinde (for Xinchai engine only)
- Protective cover for tilt cylinde
- Oil-water separator
- Master key
- Hydraulic electronic shifting
- Electronic of power off (for Xinchai engine only)
- Half-suspension vinyl seat(tiancheng)
- Grammer full-suspension vinyl seat

WE MAKE IT EASY FOR YOU

OPTIONS TO ENHANCE YOUR PRODUCTIVITY



EASY TO OWN



EASY TO CONTROL



EASY TO SERVICE



EASY TO MAINTAIN



CABIN



2ND REFINED AIR FILTER



DUAL TIRES



FULL FREE 3 STAGE MAST



BLOCK CLAMP



PUSHER



LIFTING HOOK



BALE CLAMP



HINGED CARRIAGE