

4-hour Construction Industry Confined Space Hazard

Awareness Level Training

Workbook

First Edition

Copyright © 2017

Rutgers Biomedical and Health Sciences (RBHS)

School of Public Health

All rights reserved

Table of Contents

Controlling and Managing Dynamic Hazards associated with Confined Spaces in Construction Workbook. Topics will include:

Section One: Introduction: Construction Industry Confined Space

- The New Confined Space Standard for Construction
- Planning, Coordination and Communication
- Relationship and Responsibility Flow Chart
- Exemptions to the Confined Space Construction Industry Standard
- Quick Definitions
- The Construction Industry verses the General Industry
- Construction Industry Confined Spaces vs. General Industry Confined Spaces
- Determining the Code to Follow: General Industry or Construction Industry

Section Two: Rights and Responsibilities

- Constitutional Powers of OSH Act
- Employee general safety and rights under OSH Act, including the right to file a complaint free from discrimination and the elements of a valid complaint.
- Employer responsibilities under the OSH Act General Duty Clause
- Whistleblower protection for workers under OSHA Section 11 (C) of OSHA Act.

Section Three: Confined Space Safety Training Program

Section Four: The Checklist

Section Five: Group Exercises

Section Six: Debriefing Workshop

Appendix A: CFR 1926.1200 Subpart AA Confined Spaces in Construction

Appendix B: Sample SDS

Appendix C: Confined Space Basics

Federal Disclaimer

This material was produced under grant number SH29649SH6 from the Occupational Safety and Health Administration, U.S. Department of Labor. It does not necessarily reflect the views or policies of the U.S. Department of Labor, nor does mention of trade names, commercial products, or organizations imply endorsement by the U.S. Government.

Section One: Introduction: Construction Industry Confined Space

“The Confined spaces rule could protect nearly 800 construction workers a year from serious injuries and reduce life-threatening hazards. Construction protections now match those in manufacturing and general industry”

OSHA National News Release

U.S. Department of Labor, May 1, 2015

In May of 2015, OSHA issued a new Standard for construction work in confined spaces, which became effective on August 3, 2015. Once in effect and followed, government research projects that the new Standard will protect nearly 800 construction workers a year from serious injuries and reduce life-threatening hazards associated with confined spaces found and created on construction sites. This grant was created to help both employers and employees learn about the new standard and understand more about confined spaces and permit required confined spaces (PRCS). Employers and those who manage construction related activities, where confined spaces and PRCS may be found, will find helpful guides to control hazards associated with confined spaces and learn their regulatory expectations and how to coordinate their respective activities with other entities. This grant will help assist employers with typical documentation, communication and coordination necessary for compliance. It includes helpful training modules, and other resources OSHA provides to help employers and workers understand the rule and create their own effective adherence.

This new Standard, Subpart AA of 29 CFR 1926 now provides protections for construction workers similar to those in other industries. Construction protections now match those in manufacturing and general industry, where construction activities often occur. Now, no matter where workers perform construction activities, such as toxic substances, electrocutions, explosions, and asphyxiation, there is a code to help specifically protect them. Typical construction related confined spaces include places such as manholes, crawl spaces, tanks, vessels, vaults, pipes that are not designed for continuous occupancy and are difficult to exit in the event of an emergency.

Planning, Coordination and Communication:

Managing the Construction Industry Confined Space Program

Since planning and coordination between various employers and or entities is essential to implementing an effective confined space program, this grant contains material that will help trainees learn how to plan work activity with multiple employers and share vital safety

information and monitor hazards. The sharing of responsibility between various entities to protect workers is not a new concept in the OSHA standards and in compliance. Precedent exists that requires multiple employers to multilaterally communicate and coordinate their respective activities and share information, concerning the safety and wellbeing, with associated employers. You may recognize such precedent in these areas (not comprehensive):

- Subpart R- Steel Erection: Controlling Contractor, Concrete Employer, Steel Erector.

1910.1200 Hazard Communications: Controlling contractor will share information about chemicals with multiple employers.

- Site-wide control of so called general conditions and the respective delegated responsibilities of controlling contractors on multiple employer worksites.

- Subpart CC- host, controlling Contractor, Crane Employer has the responsibility to inform contractors of existing underground hazards

- NFPA 70E: Host shares locations and specific electrical hazard information.

Relationship and Responsibility Flow Chart

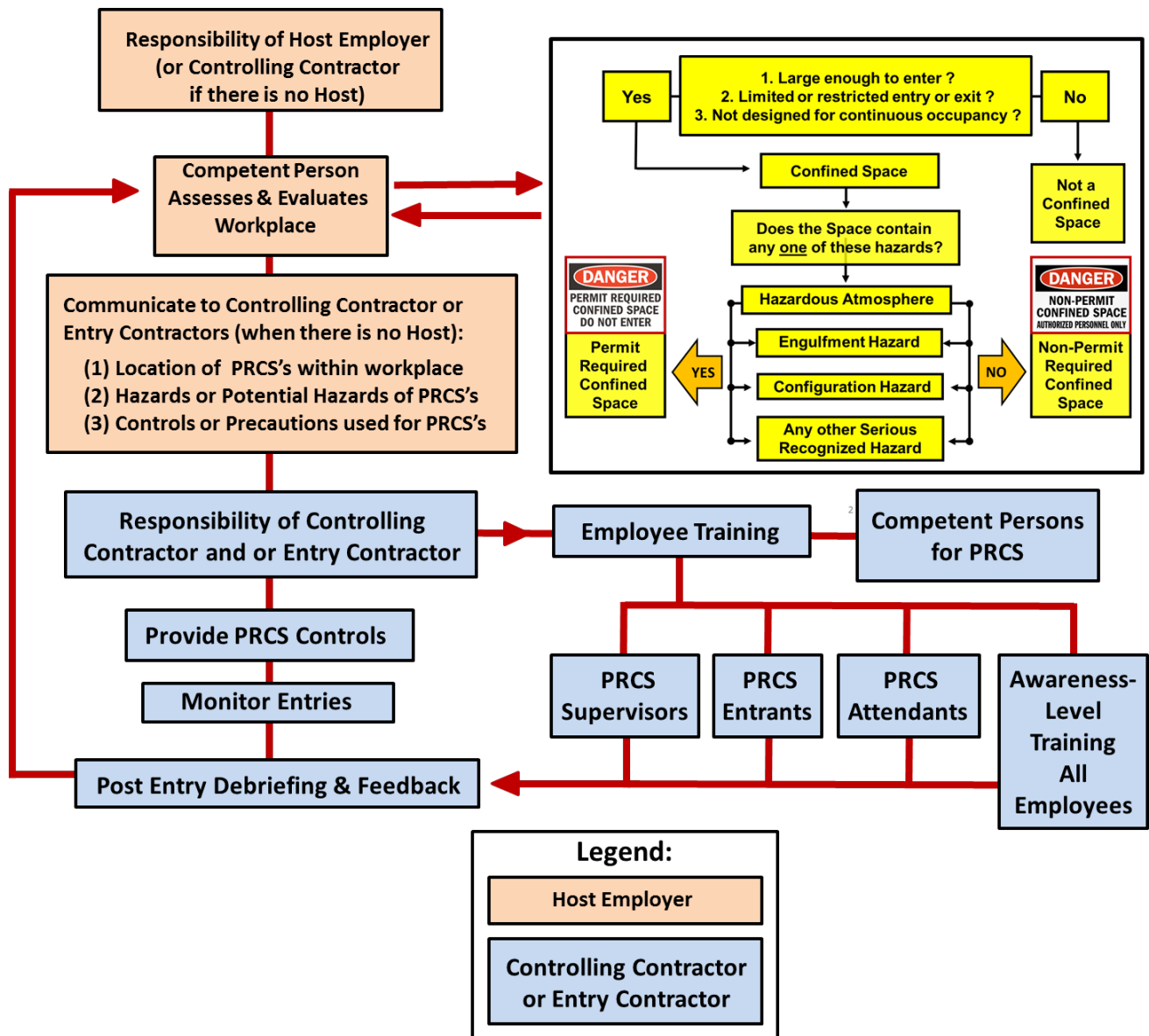

Exceptions to the new Confined Space Rule

It should be noted that this new standard has three exemptions where the standard does not apply. In cases where the standard applies and there is a provision that addresses a confined

space hazard in another applicable OSHA standard, the employer must comply with both that requirement and the applicable provisions of the following standards.

- Construction work regulated by §1926 subpart P—Excavations.
- Construction work regulated by §1926 subpart S—Underground Construction, Caissons, Cofferdams and Compressed Air.
- Construction work regulated by §1926 subpart Y—Diving.

Some Quick Definitions

Competent person means one who is capable of identifying existing and predictable hazards in the surroundings or working conditions which are unsanitary, hazardous, or dangerous to employees, and who has the authorization to take prompt corrective measures to eliminate them.

Confined space means a space that:

- (1) Is large enough and so configured that an employee can bodily enter it;
- (2) Has limited or restricted means for entry and exit; and
- (3) Is not designed for continuous employee occupancy.

Control means the action taken to reduce the level of any hazard inside a confined space using engineering methods (for example, by ventilation), and then using these methods to maintain the reduced hazard level. Control also refers to the engineering methods used for this purpose. Personal protective equipment is not a control.

Controlling Contractor is the employer that has overall responsibility for construction at the worksite.

Entry means the action by which any part of a person passes through an opening into a permit-required confined space. Entry includes ensuing work activities in that space and is considered to have occurred as soon as any part of the entrant's body breaks the plane of an opening into the space, whether or not such action is intentional or any work activities are actually performed in the space.

Entry Employer means any employer who decides that an employee it directs will enter a permit space.

Hazard means a physical hazard or hazardous atmosphere.

Hazardous atmosphere means an atmosphere that may expose employees to the risk of death, incapacitation, impairment of ability to self-rescue (that is, escape unaided from a permit space), injury, or acute illness from one or more of the following causes:

- (1) Flammable gas, vapor, or mist in excess of 10 percent of its lower flammable limit (LFL);
- (2) Airborne combustible dust at a concentration that meets or exceeds its LFL;
- (3) Atmospheric oxygen concentration below 19.5 percent or above 23.5 percent;
- (4) Atmospheric concentration of any substance for which a dose or a permissible exposure limit is published in Subpart D—Occupational Health and Environmental Control, or in Subpart Z—Toxic and Hazardous Substances, of this part and which could result in employee exposure in excess of its dose or permissible exposure limit;

Note. An atmospheric concentration of any substance that is not capable of causing death, incapacitation, impairment of ability to self-rescue, injury, or acute illness due to its health effects is not covered by this definition.

- (5) Any other atmospheric condition that is immediately dangerous to life or health.

Host employer means the employer that owns or manages the property where the construction work is taking place.

Note. If the owner of the property on which the construction activity occurs has contracted with an entity for the general management of that property, and has transferred to that entity the information specified in §1203(h)(1), OSHA will treat the contracted management entity as the host employer for as long as that entity manages the property. Otherwise, OSHA will treat the owner of the property as the host employer. In no case will there be more than one host employer.

Hot work means operations capable of providing a source of ignition (for example, riveting, welding, cutting, burning, and heating).

Immediately dangerous to life or health (IDLH) means any condition that would interfere with an individual's ability to escape unaided from a permit space and that poses a threat to life or that would cause irreversible adverse health effects.

Note. Some materials—hydrogen fluoride gas and cadmium vapor, for example—may produce immediate transient effects that, even if severe, may pass without medical attention, but are followed by sudden, possibly fatal collapse 12-72 hours after exposure. The victim "feels normal" after recovery from transient effects until collapse. Such materials in hazardous quantities are considered to be "immediately" dangerous to life or health.

Limited or restricted means for entry or exit means a condition that has a potential to impede an employee's movement into or out of a confined space. Such conditions include, but are not limited to, trip hazards, poor illumination, slippery floors, inclining surfaces and ladders.

Line breaking means the intentional opening of a pipe, line, or duct that is or has been carrying flammable, corrosive, or toxic material, an inert gas, or any fluid at a volume, pressure, or temperature capable of causing injury.

Lockout means the placement of a lockout device on an energy isolating device, in accordance with an established procedure, ensuring that the energy isolating device and the equipment being controlled cannot be operated until the lockout device is removed.

Lower _ flammable limit or lower explosive limit means the minimum concentration of a substance in air needed for an ignition source to cause a flame or explosion.

Monitor or monitoring means the process used to identify and evaluate the hazards after an authorized entrant enters the space. This is a process of checking for changes that is performed in a periodic or continuous manner after the completion of the initial testing or evaluation of that space.

Non-entry rescue occurs when a rescue service, usually the attendant, retrieves employees in a permit space without entering the permit space.

Non-permit confined space means a confined space that meets the definition of a confined space but does not meet the requirements for a permit-required confined space, as defined in this subpart.

Permit-required confined space (permit space) means a confined space that has one or more of the following characteristics: (1) Contains or has a potential to contain a hazardous atmosphere; (2) Contains a material that has the potential for engulfing an entrant; (3) Has an internal configuration such that an entrant could be trapped or asphyxiated by inwardly converging walls or by a floor which slopes downward and tapers to a smaller cross-section; or (4) Contains any other recognized serious safety or health hazard.

Physical hazard means an existing or potential hazard that can cause death or serious physical damage. Examples include, but are not limited to: explosives (as defined by paragraph (n) of §1926.914, definition of “explosive”); mechanical, electrical, hydraulic and pneumatic energy; radiation; temperature extremes; engulfment; noise; and inwardly converging surfaces. Physical hazard also includes chemicals that can cause death or serious physical damage through skin or eye contact (rather than through inhalation).

Qualified person means one who, by possession of a recognized degree, certificate, or professional standing, or who by extensive knowledge, training, and experience, has successfully demonstrated his ability to solve or resolve problems relating to the subject matter, the work, or the project.

Serious physical damage means an impairment or illness in which a body part is made functionally useless or is substantially reduced in efficiency. Such impairment or illness may be

permanent or temporary and includes, but is not limited to, loss of consciousness, disorientation, or other immediate and substantial reduction in mental efficiency. Injuries involving such impairment would usually require treatment by a physician or other licensed health-care professional.

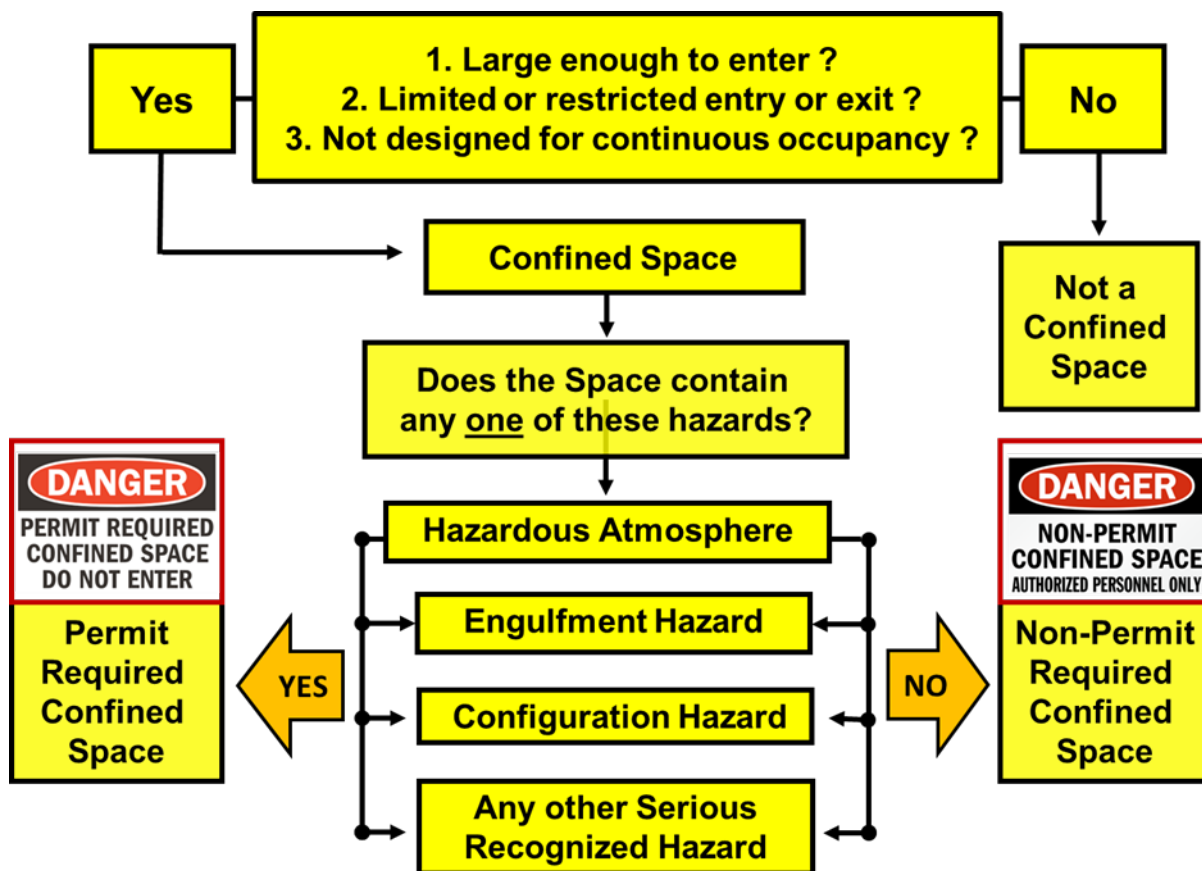

Note: The hazards that would trigger the permit-required confined space provisions: (1) contains or has the potential to contain a hazardous atmosphere; (2) contains a material that has the potential for engulfing an entrant; (3) has an internal configuration such that an entrant could be trapped or asphyxiated by inwardly converging walls or by a floor which slopes downward and tapers to a smaller cross-section; or (4) contains any other recognized serious safety or health hazard (see 1926.1202).

Construction Industry Confined Spaces vs. General Industry Confined Spaces

If you are familiar with the general industry standard regarding confined spaces you should know that there are several key differences between the construction confined space codes. Some of these key differences include:

1. More detailed provisions requiring coordinated activities when there are multiple employers at the worksite (for more detail, see question 16, below). This will ensure hazards are not introduced into a confined space by workers performing tasks outside

the space. An example would be a generator running near the entrance of a confined space causing a buildup of carbon monoxide within the space.

2. Requiring a competent person to evaluate the work site and identify confined spaces, including permit spaces.
3. Requiring continuous atmospheric monitoring whenever possible.
4. Requiring continuous monitoring of engulfment hazards. For example, when workers are performing work in a storm sewer, a storm upstream from the workers could cause flash flooding. An electronic sensor or observer posted upstream from the work site could alert workers in the space at the first sign of the hazard, giving the workers time to evacuate the space safely.
5. Allowing for the suspension of a permit, instead of cancellation, in the event of changes from the entry conditions list on the permit or an unexpected event requiring evacuation of the space. The space must be returned to the entry conditions listed on the permit before re-entry.
6. Requiring that employers who are relying on local entities for emergency services to arrange for those responders to give the employer advance notice if they will be unable to respond for a period of time
7. Requiring employers to provide training in a language and vocabulary that the employee understand

Some Clarifications to the new rule;

In addition, OSHA has added provisions to the new rule that clarifies existing requirements in the General Industry Standard. These include:

1. Requiring that employers who direct workers to enter a space without using a complete permit system prevent workers' exposure to physical hazards through elimination of the hazard or isolation methods such as lockout/tagout.
2. Requiring that employers who are relying on local emergency services for emergency services arrange for responders to give the employer advance notice if they will be unable to respond for a period of time (because they are responding to another emergency, attending department-wide training, etc.).
3. Requiring employers to provide training in a language and vocabulary that the worker understands.
4. Finally, several terms have been added to the definitions for the construction rule, such as "entry employer" to describe the employer who directs workers to enter a space, and "entry rescue", added to clarify the differences in the types of rescue employers can use

Determining the Code to Follow: General Industry or Construction Industry

The difference between construction and maintenance is the activity to be performed. "Maintenance" means keeping equipment or a structure in proper condition through routine, scheduled or anticipated measures without having to significantly alter the structure or equipment in the process. For equipment, this generally means keeping the equipment working properly by taking steps to prevent its failure or degradation. Here are respective examples of maintenance and construction:

Example No. 1: Maintenance

A common household water shut-off valve in a home heating system is removed and replaced. Its replacement is part of the routine maintenance of the system and removing and replacing the valve is done without making major alterations to the heating system. The removal and replacement of the valve would be considered maintenance.

Example No. 2: Construction

A 36 inch valve that is one of three major components in a processing system is removed and replaced. To do the job, 50 percent of all parts in the system have to be cut, unbolted, moved, or otherwise altered or replaced. Removing and replacing this valve would be considered construction because the valve constitutes a major portion of the equipment it is in and much of the rest of the system's parts must be moved or altered in the process of doing the jo

Section Two: Rights and Responsibilities

Responsibilities under the OSH Act: General Duty Clause

It is both wise and mandatory for an employer to start any undertaking with some reasonable anticipation of what hazards and obstacles you may likely encounter because it is essential that in each workplace an employer provides the means of assessing and identifying potential hazards and where applicable utilize measures that seek to eliminate, prevent and protect such hazards from causing harm. It is critical that you perform an assessment of your existing Temporary Worker Safety & Health Program to see if you can benchmark it against, code, best practice and industry Standards.

We must always keep in mind the mandatory nature of program management flows directly from The Williams-Steiger Occupational Safety and Health Act of 1970, which can also be referred to as, “The Occupational Safety and Health Act of 1970” (OSH Act). The primary purpose of the OSH Act is to assure, so far as possible, safe and healthful working conditions for every working man and woman, but in various places the OSH Act or OSHA regulations clearly spells out the responsibility of an employer and employees:

The Occupational Safety and Health Act of 1970: “General Duty Clause”

5. General Duties

(a) Each employer

(1) shall furnish to each of his employees employment and a place of employment which are free from recognized hazards that are causing or are likely to cause death or serious physical harm to his employees;

(2) Shall comply with occupational safety and health Standards promulgated under this Act.

(b) Each employee shall comply with occupational safety and health Standards and all rules, regulations, and orders issued pursuant to this Act which are applicable to his own actions and conduct.

Additional Worker Rights

- Among other employer responsibilities a worker also has the right to:
- Be trained in a language the worker understands
- Work on machines, tools and equipment that are in safe working condition
- Be provided required safety gear, such as gloves or a harness and lifeline for falls
- Be trained and protected from hazardous and toxic chemicals
- Request an OSHA inspection, and speak to the inspector

- Report an injury or illness, and receive copies of their medical records
- See and examine copies of the workplace injury and illness log for the employer
- Review records of work-related injuries and illnesses
- Get copies of test results done to find hazards in the workplace

Employer Responsibility

- Under the OSH law, employers have a responsibility to provide a safe workplace. This is a short summary of key employer responsibilities:
- Provide a workplace free from serious recognized hazards and comply with standards, rules and regulations issued under the OSH Act.
- Examine workplace conditions to make sure they conform to applicable OSHA standards.
- Make sure employees have and use safe tools and equipment and properly maintain this equipment.
- Use color codes, posters, labels or signs to warn employees of potential hazards.
- Establish or update operating procedures and communicate them so that employees follow safety and health requirements.
- Provide safety training in a language and vocabulary workers can understand.
- Employers with hazardous chemicals in the workplace must develop and implement a written hazard communication program and train employees on the hazards they are exposed to and proper precautions (and a copy of safety data sheets must be readily available). See the OSHA page on Hazard Communication.
- Provide medical examinations and training when required by OSHA standards.
- Post, at a prominent location within the workplace, the OSHA poster (or the state-plan equivalent) informing employees of their rights and responsibilities.
- Report to the nearest OSHA office all work-related fatalities within 8 hours, and all work-related inpatient hospitalizations, all amputations and all losses of an eye within 24 hours. Call our toll-free number: 1-800-321-OSHA (6742); TTY 1-877-889-5627. [Employers under federal OSHA's jurisdiction were required to begin reporting by Jan. 1, 2015. Establishments in a state with a state-run OSHA program should contact their state plan for the implementation date].
- Keep records of work-related injuries and illnesses. (Note: Employers with 10 or fewer employees and employers in certain low-hazard industries are exempt from this requirement.
- Provide employees, former employees and their representatives access to the Log of Work-Related Injuries and Illnesses (OSHA Form 300). On February 1, and for three months, covered employers must post the summary of the OSHA log of injuries and illnesses (OSHA Form 300A).
- Provide access to employee medical records and exposure records to employees or their authorized representatives.
- Provide to the OSHA compliance officer the names of authorized employee representatives who may be asked to accompany the compliance officer during an inspection.
- Not discriminate against employees who exercise their rights under the Act. See our "Whistleblower Protection" webpage.

- Post OSHA citations at or near the work area involved. Each citation must remain posted until the violation has been corrected, or for three working days, whichever is longer. Post abatement verification documents or tags.
- Correct cited violations by the deadline set in the OSHA citation and submit required abatement verification documentation.

The Whistleblower Protection Programs: How to File a Discrimination Complaint

File a discrimination complaint if your employer has retaliated against you for exercising your rights as an employee. If you have been punished or retaliated against for exercising your rights under the OSH Act, **you must file a complaint with OSHA within 30 days of the alleged reprisal.** In states with approved state plans, employees may file a complaint under the OSH Act (Section 11(c)) with both the State and Federal OSHA.

- Complaints need to be filed within 30 days after an alleged retaliation.
- You may file complaints by: telephone calling (800) 321-OSHA for situations where you believe there is an immediate risk that threatens life or injury or call a local area office (number listed below) , you can also go online at <http://www.osha.gov/as/opa/worker/complain.html> and download forms for faxing OSHA at: <http://www.osha.gov/oshforms/osha7.pdf> Contact your local OSHA office as soon as possible, because you must file your complaint within the legal time limits. New York (212) 337-2378
- OSHA will conduct an in-depth interview with each complainant. The investigation must reveal that:
 - The employee engaged in protected activity;
 - The employer knew about the protected activity;
 - The employer took an adverse action; and
 - The protected activity was the motivating factor, or under some laws, a contributing factor in the decision to take the adverse action against the employee.
- Letter - You may also send a letter describing your complaint to your local OSHA Regional or Area Office. Please include your name, address and telephone number so we can contact you to follow up.
- OSHA will accept your complaint in any language.
- OSHA conducts an interview with each complainant to determine the need for an investigation. If evidence supports the worker's claim of discrimination, OSHA will ask the employer to restore the worker's job, earnings and benefits.



Right to Be Hard: Your Rights as a Whistleblower

OSHA's Whistleblower Protection Program enforces the whistleblower provisions of more than twenty whistleblower statutes. Rights afforded by these whistleblower acts include, but are not limited to, worker participation in safety and health activities, reporting a work related injury, illness or fatality, or reporting a violation of the statutes.

Protection from discrimination means that an employer cannot retaliate by taking "adverse action" against workers, such as:

- | | |
|--|---|
| <input type="checkbox"/> Firing or laying off | <input type="checkbox"/> Failure to hire or rehire |
| <input type="checkbox"/> Blacklisting | <input type="checkbox"/> Intimidation |
| <input type="checkbox"/> Demoting | <input type="checkbox"/> Making threats |
| <input type="checkbox"/> Denying overtime or promotion | <input type="checkbox"/> Reassignment affecting prospects for promotion |
| <input type="checkbox"/> Disciplining | <input type="checkbox"/> Reducing pay or hours |
| <input type="checkbox"/> Denial of benefits | |

Limited Right to Refuse to Work

REFUSING WORK IS PROTECTED IF: Your right to refuse to do a task is protected if ALL of the following conditions are met:

- Where possible, you have asked the employer to eliminate the danger, and the employer failed to do so; and
- You refused to work in "good faith." This means that you must genuinely believe that an imminent danger exists. Your refusal cannot be a disguised attempt to harass your employer or disrupt business; and
- A reasonable person would agree that there is a real danger of death or serious injury; and
- There isn't enough time, due to the urgency of the hazard, to get it corrected through regular enforcement channels, such as requesting an OSHA inspection.

WHEN CONDITIONS ARE MET, NEXT STEPS: When all of the above conditions are met, you can take the following steps:

- Ask your employer to correct the hazard;
- Ask your employer if there is other work you can perform that is free from hazards;
- Tell your employer that you won't perform the work unless and until the hazard is corrected; and
- Remain at the worksite until ordered to leave by your employer. (If the worksite is unsafe and poses an imminent risk of danger you should remove yourself from the worksite)

How to File a Safety and Health Complaint

The Occupational Safety and Health Act of 1970 gives employees and their representatives the right to file a complaint and request an OSHA inspection of their workplace if they believe there is a serious hazard or their employer is not following OSHA standards. Workers do not have to know whether a specific OSHA standard has been violated in order to file a complaint. The complaint should be filed as soon as possible after noticing the hazard or lack of compliance because OSHA citations may only be issued for violations that currently exist or existed in the past 6 months.

If the worker believes working conditions are unsafe or unhealthful, the worker may file a confidential complaint with OSHA and ask for an inspection. If possible, bring the conditions to the employer's attention. Workers do not have to know whether a specific OSHA standard has been violated in order to file a complaint. The complaint should be filed as soon as possible after noticing the hazard or lack of compliance because OSHA citations may only be issued for violations that currently exist or existed in the past 6 months. Do Not Report an emergency, fatality, or imminent life threatening using a Complaint Form or Email. To report an emergency, fatality, or imminent life threatening situation please contact toll free number 1-800-321-OSHA (6742) TTY 1-877-889-5627 immediately.

The worker also has the right to file a complaint with OSHA if the employer retaliates against them or takes unfavorable personnel action because the employee engaged in protected activity relating to workplace safety and health (See whistleblower program above).

- Online – Go to the Online Complaint Form: Written complaints that are signed by workers or their representative and submitted to an OSHA Area or Regional office are more likely to result in onsite OSHA inspections. Complaints received on line from workers in OSHA-approved state plan states will be forwarded to the appropriate state plan for response.
- Fax/Mail - Download the OSHA complaint form [En Espanol] (or request a copy from your local OSHA Regional or Area Office): Complete it and then fax or mail it back to your local OSHA Regional or Area Office. Written complaints that are signed by a worker or representative and submitted to the closest OSHA Area Office are more likely to result in onsite OSHA inspections. Please include your name, address and telephone number so we can contact you to follow up.
- Telephone – your local OSHA Regional or Area Office: OSHA staff can discuss your complaint and respond to any questions you have. If there is an emergency or the hazard is immediately life-threatening, call your local OSHA Regional or Area Office or 1-800-321-OSHA.

Note: Complaints from workers or their representatives are taken seriously by OSHA. OSHA will keep your information confidential.

Section Three: Confined Space Safety Training Program

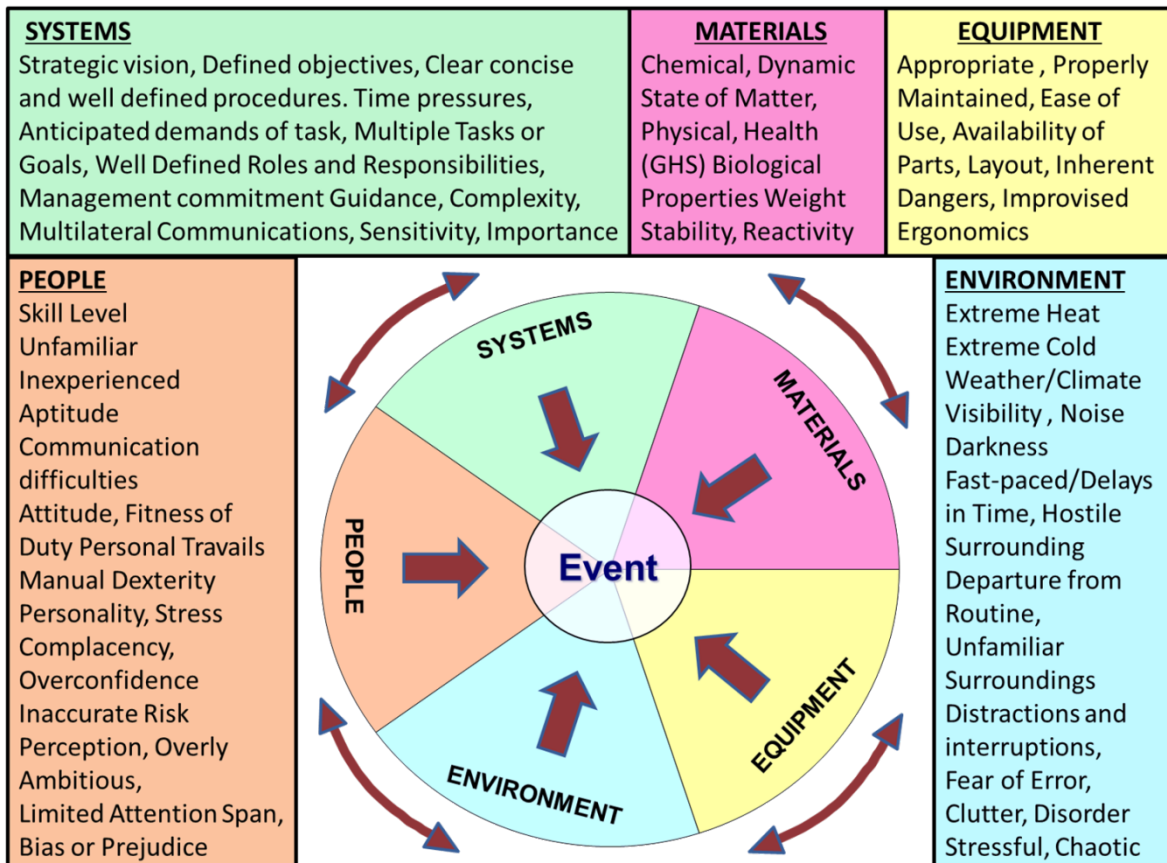

The following sample training modules are for workers to help them better understand what confined spaces are and the nature of hazards associated with these spaces. This training should be provided to all employees who will be exposed to confined spaces and permit required confined spaces. This training is a sample of core elements to cover and must be trained in a language and a aptitude that workers can readily understand so they can readily apply their knowledge and skill in the field. This training is NOT intended for workers who will enter permit required confined spaces, such training must be much more involved and completely specific to the hazards associated with the permit required spaces they will enter.

YOUR COMPANY NAME HERE

Construction Industry Confined Space Training Program (SAMPLE)

Key Elements to Training Employees who will be exposed to Confined Spaces

- 1. General Awareness-level Confined Space Training Module**
- 2. Flammable Atmospheres Module**
- 3. Oxygen Deficient and Enriched Atmospheres Module**
- 4. Vapor Density and Specific Gravity Module**
- 5. The Control of Hazardous Energy Module**
- 6. Oxidizing Agents Module**
- 7. Rescue Module**

1. General Awareness-level Confined Space Training Module

In keeping with recent additions to the United States Department of Labor's Occupational Safety and Health Administration (OSHA) Standards concerning confined spaces in construction, our team at YOUR COMPANY NAME HERE has compiled a self-guided lesson for our workforce and administrators to ensure that we are all aware of what constitutes a confined space and a permit required confined space and how such spaces can be or can become hazardous to your safety and health. Review this exercise with your competent persons. It's important to know that this awareness-level training is intended to make you generally aware of the existence and terms associated with confined spaces, but it DOES NOT provide enough training to make you able to enter such spaces. Worker entry into such spaces requires additional more rigorous space-specific training. The intent here is to teach our team to be able to "RAP," that is, RECOGNIZE, AVOID and PREVENT exposures to these hazardous spaces.

This change in Standard is designed to save lives of construction workers. Unlike most general industry worksites, construction sites are continually evolving, with the number and characteristics of confined spaces changing as work progresses. Occasionally, the materials we work with or the work activities we perform can create dangerous conditions that would classify our working environment as a confined space or worse a permit required confined space. This new OSHA rule emphasizes the necessity of training as well as continuous worksite evaluation and communication. The Standard also holds various entities accountable for our worksites including controlling contractors, hosts and owners of facilities. These entities are required by OSHA to share information of known or foreseeable confined space and the respective hazards that we may encounter while at work.

We should know that the host, controlling contractor (often referred to as the General Contractor) along with YOUR COMPANY NAME HERE competent person MUST make you aware of specific confined spaces at our worksites. They must brief you on the location of specific confined spaces and respective associated hazards in your work environment. If no confined or permit required confined spaces exist at your worksite then the absence of such spaces must be communicated to you.

It's important to know terms surrounding confined spaces. There are exceptionally hazardous confined spaces that OSHA terms Permit Required Confined Spaces that possess, or could possess, conditions within that can cause or possibly cause death, serious injury or illness. The host/owner of the facility you are working at is responsible to maintain a Confined Space Program that inventories these spaces and their respective hazards.

It is critical that we understand the terms and hazards associated with confined spaces in our working environments. This tutorial will be followed by a 20 question exercise.



Confined Space examples: vaults, pipes, ducts, crawl spaces, attics, ceiling plenums, attics, pits, tanks.

What Is a Confined Space?

It's vital that we all know what is meant by a Confined Space. In order for a space to be classified as a confined space it must possess ALL OF THE FOLLOWING 3 CRITERIA.

1. The space must be large enough for a worker to enter that is, it must have a diameter of at least 18 inches round. Keep in mind any opening smaller than an 18 inch diameter round is considered too small to ever enter and shall not ever be entered.

2. The space must have a limited or restricted means of entry and exit. This typically means that a worker has to contort their body to enter, such as crouching, bending, crawling and kneeling to enter the space. A non-Standard doorway a hatchway, scuttle, manhole, inspection port including spaces only accessible by ladders, concrete-mounted rungs or hoisting devices. A space with a limited number of means of egress, such as single way in and out may constitute a limited means of entry and exit.

3. The space was not designed for continuous occupancy. Even if occasionally workers will enter the space for inspection, repair, clean-up and maintenance the space may still not be

designed for continuous occupancy. Product storage areas, enclosed machinery, vessel tanks, ceiling plenums, attics and crawl spaces are NOT designed for continuous occupancy and hence fulfill this prohibiting design criterion. Other typical confined spaces are boilers, furnaces, ceilings, pipelines, ducts, pits, pumping stations, process vessels, septic tanks, trenches, excavations, silos, storage tanks, barges, sewers, utility vaults, shafts and caissons. Such spaces may include areas above ceilings, catwalks, catacomb or maze-like paths or areas below a raised stage or electronic floor, cubbyholes or sub-basements. Our activity or the materials we use may also affect our working environment and create confined spaces or permit required confined spaces. When accessing certain areas to work, we must be deliberate when staging where we work and how we are going to access such work. For example if we were to have to work, as Michelangelo did on the Sistine Chapel, lying on our backs, this area can conceivably become a confined space. Use this as a basis of consideration; if you have to work in a position or location where it would become difficult for rescuers to extricate you from that space in an emergency, then you are probably in a confined space.

We as a team, through our competent persons, must also say something if we see something, that is, if we recognize various spaces in our work environments that resemble what we have described here, we must tell our competent persons and avoid entry until the space is assessed and classified accordingly.

What is a Permit Required Confined Space?

While we can ordinarily deal with typical confined spaces in the workplace the stakes get much greater if the confined spaces possess additional hazards that can cause Immediate Danger of Life or Health, known as an IDLH. These extremely dangerous spaces can only be entered with extreme precautions and under the permission of a permit created specifically for the hazards associated with the space. In these cases, entrants, attendants, supervisors and competent persons must receive extensive site and hazard specific training that effectively teaches workers about the specific hazards and the planning to control the hazard from doing harm. Training will also include how to monitor hazards and emergency measures to be taken to rescue entrants.

In order for a confined space to be classified as a permit required confined space it must ONLY need to possess or have the potential to possess ONE of the following criteria.

1. The space contains or has the potential to contain a hazardous atmosphere. This means the space may have or possess the potential to have an enriched or depleted oxygen atmosphere, a toxic atmosphere containing a harmful substance or chemical, a combustible or harmful dust atmosphere or a flammable atmosphere.

2. The space contains or has the potential to contain a material that can engulf an entrant such as steam, water, sewage, grain or soil.

3. The space contains a design that possess a configuration that could trap or asphyxiate an entrant. Such configuration may include internal walls or baffles, nooks, ducts or obstructions to egress that would make emergency extrication difficult or time consuming.

4. The forth criteria is intentionally open-ended and includes any serious safety or health concern that may be within a space or can potentially come into existence in the space. These hazards pose a threat to life or health (IDLH) and can be electrical hazards, pests, animals, ionizing radiation, impalements, punctures, falls, caught-in-between and struck-by hazards and various non-atmospheric chemicals.

A permit documents the steps taken to control or eliminate the hazard before entry is made, and serves as a guideline for acceptable entry conditions.

Here are some key points and important definitions you MUST remember:

- Before you begin working at a worksite you must be informed by your competent person about confined spaces that you may be directed to work in or near. These spaces must be identified by specific hazards.
- If there are permit required confined spaces at your site they must possess signage or other means of prohibiting unauthorized entry the sign may say “DANGER -- PERMIT-REQUIRED CONFINED SPACE, DO NOT ENTER” or use other similar language.
- Remember the chemicals we use or the activities we perform in a space can introduce a new hazard that would make that space into a confined space or a permit required confined space. For example hot work, which is any task that produces a spark, arc, or any other ignition source such as molten metal.
- Permit required confined spaces possess or can possibly possess hazards that can immediately cause death or serious sickness or injury. We refer to such hazards as “IDLH’s,” which stands for “Immediate Danger of Life or Health.”
- Entry into a confined or permit required confined space means any body part that breaks the plane or opening to the space. Reaching into a space with your hand or arm would constitute an entry.
- A Competent person means one who is capable of identifying existing and predictable hazards in the surroundings or working conditions which are unsanitary, hazardous, or dangerous to employees, and who has the authorization to take prompt corrective measures to eliminate them. You MUST have a competent person at your site at all times.
- The Controlling Contractor is the employer that has overall responsibility for construction at the worksite. This is typically

the General Contractor. If the controlling contractor owns or manages the property, then it is both a controlling employer and a host employer.

- The Host employer means the employer that owns or manages the property where you are working.
- A Hazardous atmosphere means an atmosphere that may expose employees to the risk of death, incapacitation, impairment, injury, or illness from such hazards as flammable gases, combustible dusts, atmospheric oxygen concentration below 19.5 percent or above 23.5 percent and concentrations of recognized toxic and hazardous substance or any other atmospheric condition that is immediately dangerous to life or health.

Confined Space Identification Flow Chart

Here is a simple flow chart that can help you better understand how we classify confined and permit required confined spaces. If you have any questions please ask your competent person.

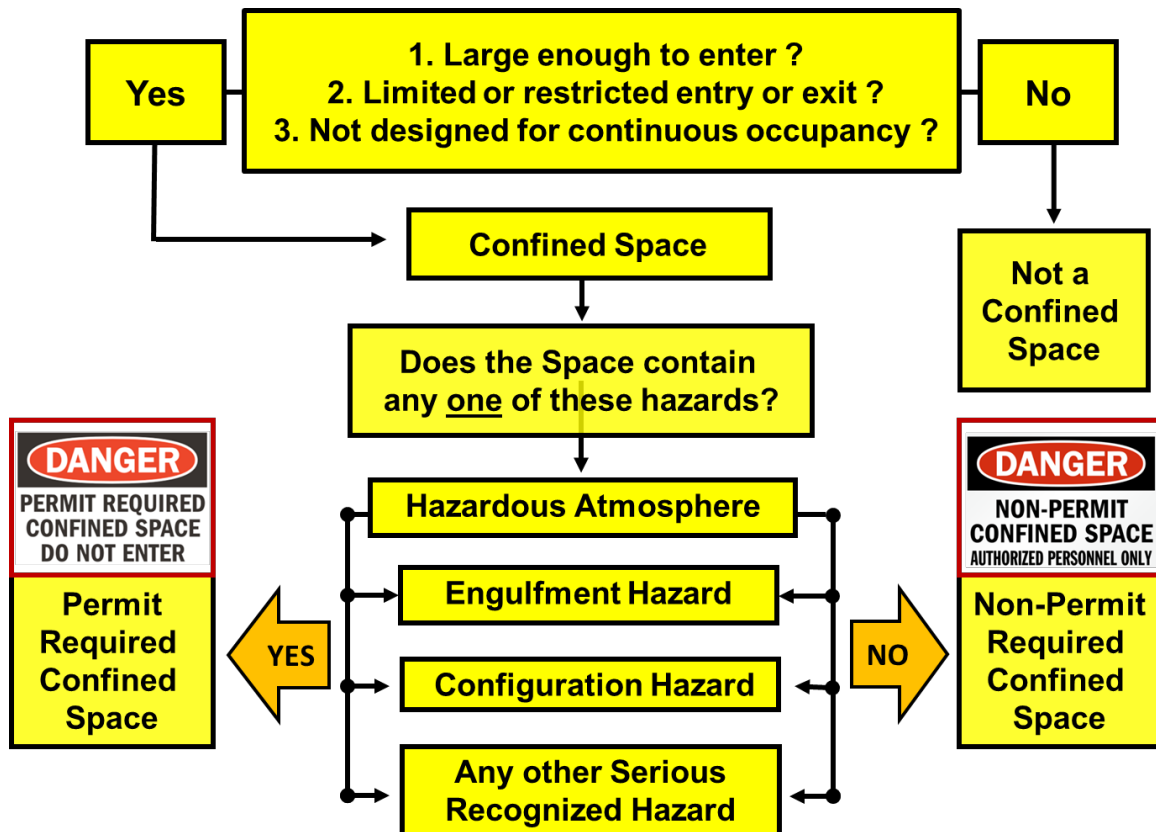

2. Flammable Atmospheres Module

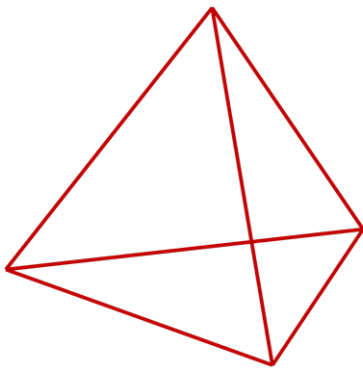

A Tetrahedron

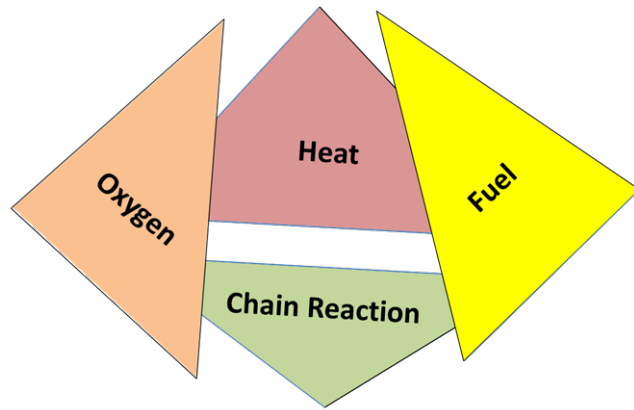

The Fire Tetrahedron

The fire tetrahedron include 4 necessary components

1. Fuel (something that will burn)
2. Heat (enough to make the fuel burn)
3. Oxygen (enough to support combustion)
4. Uninhibited chain reaction

Formerly the use of the fire triangle included on three components fuel, heat, oxygen. These three components must be present to have a fire but an uninhibited chain reaction must also be present. According to the National Fire Protection Association (NFPA) a fire tetrahedron more accurately describes the mechanism of a fire. In a real sense a fire is actually an event.

Fire Classifications

Fires are classified according to the type of fuel that is burning

Class A - ordinary combustibles



Class B - flammable liquids



Class C - electrical fires



Class D - metals fires



Note: A Class K fire is a kitchen fire (grease fire).

The LFL and UFL and The Flammable Range

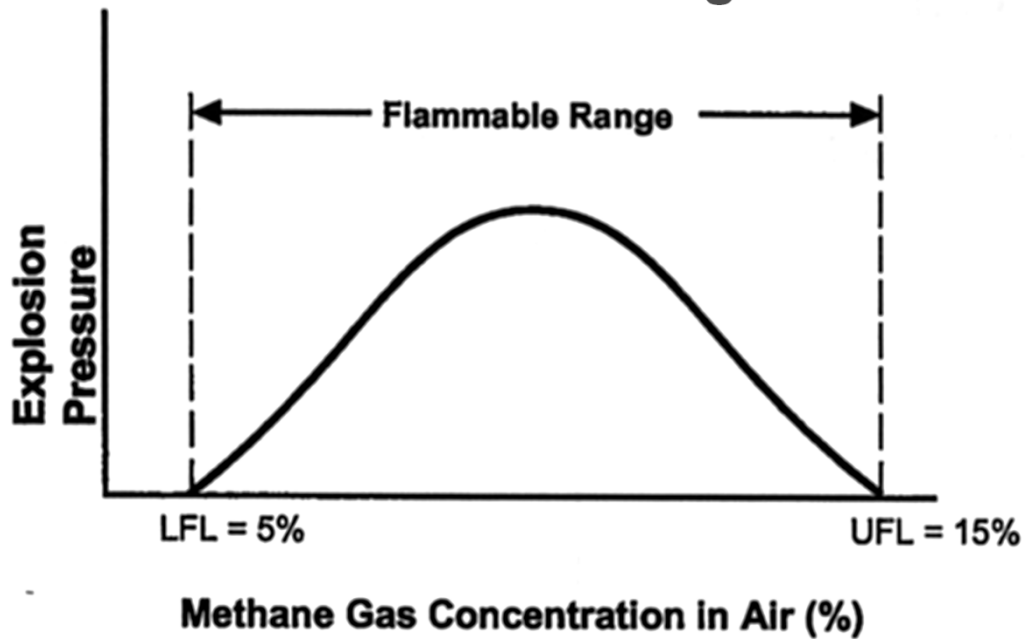

3. Oxygen Deficient and Enriched Atmospheres Module

An oxygen deficient atmosphere means an atmosphere containing less than 19.5 percent oxygen by volume and an oxygen enriched atmosphere means an atmosphere containing more than 23.5 percent oxygen by volume. These two states of concentration have pose different hazards to entrants inside of confined spaces. Oxygen enrichment increase volatility inside the space meaning the atmosphere could become explosive. Oxygen deficient atmospheres impair our breathing and can lead to asphyxiation. Oxygen is a very most important element and is also a fundamental part of combustion.

- Oxygen is essential to life. Its normal concentration in the air we breathe is approximately 21 % (20.9%)
- OSHA 19.5 % to 23.5 %
- We can breathe in a 50-60% oxygen enriched atmosphere for several hours under medical care (oxygen therapy)
- Oxygen is not flammable but supports combustion.
- Most materials burn fiercely sometimes explosively in oxygen.
- As the oxygen concentration in air increases, the potential fire risk increases. Oxygen enrichment cannot be detected by the human senses
- At concentrations above 23.5 % in air, the situation becomes dangerous due to the increased fire hazard.
- Oxygen is colourless, tasteless and has no odour.
- Oxygen is heavier than air, oxygen can accumulate in low lying areas. such as pits or underground rooms especially in cases of liquid spillage.
- 3 Means of losing oxygen
 - Displacement
 - Consumption
 - Reaction

4. Vapor Density and Specific Gravity Module

Specific gravity and relative vapor density

Specific gravity and vapor density comparative measurements based on the respective relative weight of a liquid and a gas or vapor compared to water or air. This “weight” of water or air is an arbitrary value of one (1). If a gas has a vapor density of less than one it will generally rise in air. If the vapor density is greater than one the gas will generally sink in air. Propane for example has a vapor density of 1.554, so it will sink in air, the vapor density of helium is 0.145 so it is significantly lighter than air so it will rise. Acetone is twice as heavy as air so its vapor density is 2. Mercury vapor is nearly seven times heavier the air. As you would imagine, the density of a chemical has great safety and health implications for example storage of chemicals

especially flammables, oxidizers or other highly reactive chemicals that can displace air, possibly presenting hazard to employees.

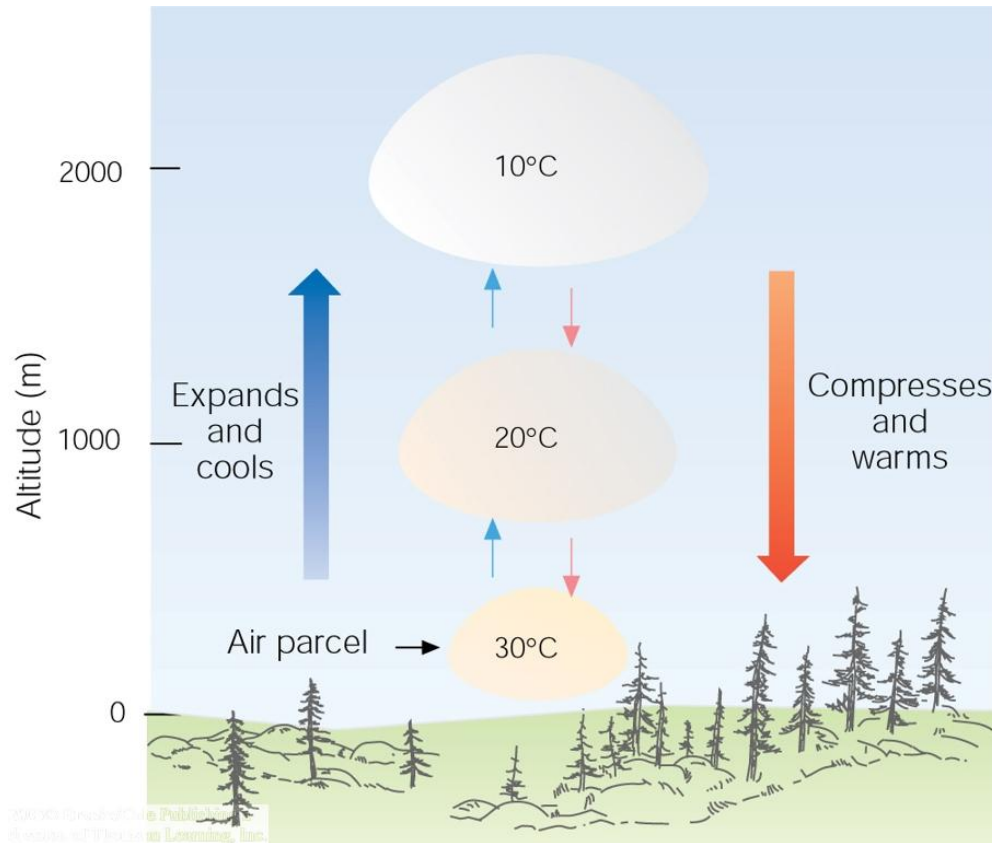

Vapor Density and Specific Gravity are subject to environmental conditions.

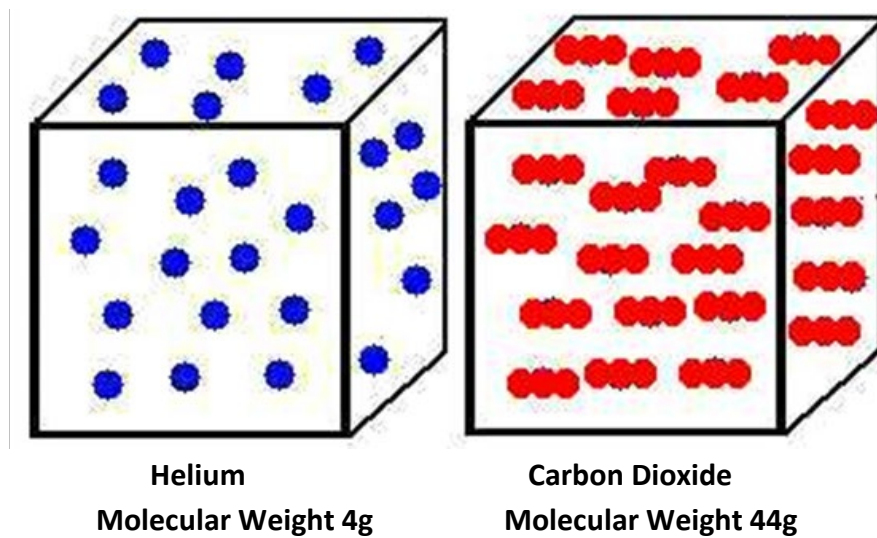

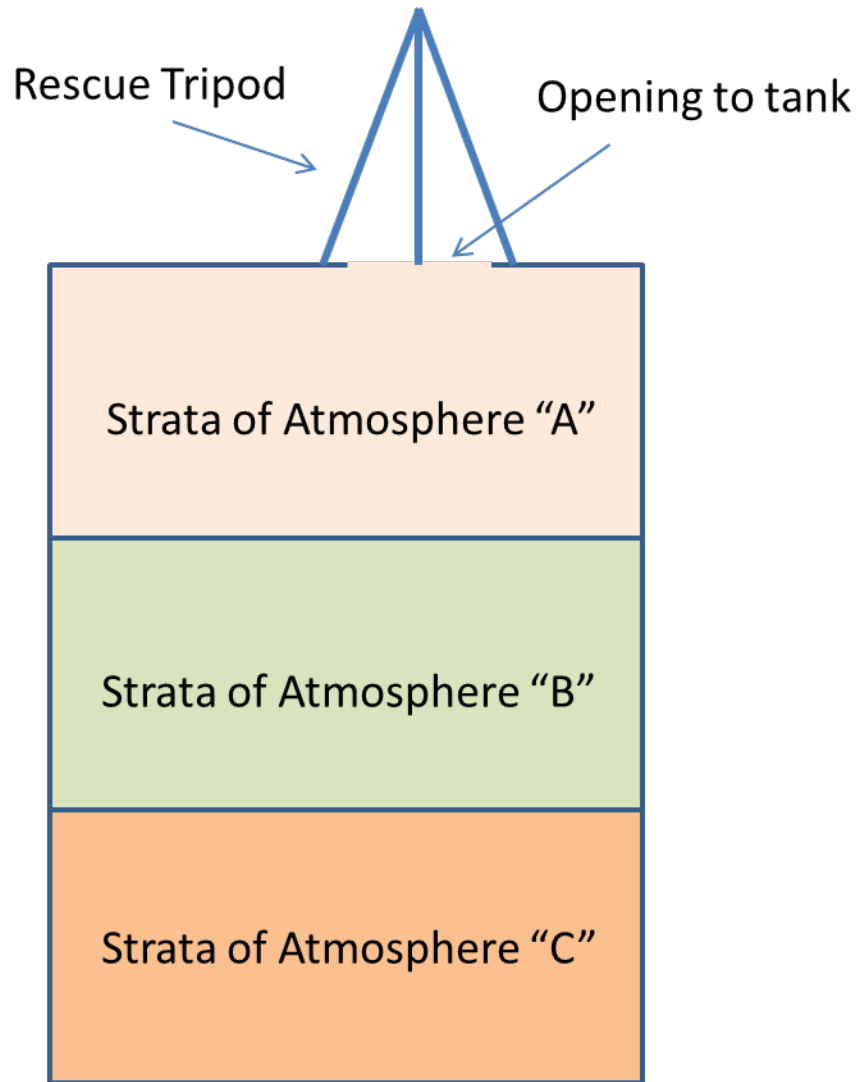

Different Vapor Densities
in a PRCS Tank Entry

5. The Control of Hazardous Energy Module

Dr. William Haddon Jr. a physician with degrees from the Massachusetts Institute of Technology, Harvard Medical School and Harvard School of Public Health and the first director of the National Highway Traffic Safety Administration, proposed a general idea that accidents and injuries involve the transfer of energy. His theory is known as the Energy Release Theory, it poses that objects, events, or environments interaction with people cause harm. Many sources of energy are obvious to us such as the moving parts of a machine, motor vehicles, projectiles, gravity, or even wind and weather systems yet we often overlook the tremendous energy found in chemicals simply because we cannot see the energy. To control hazardous energy we have developed procedures commonly referred to as Lock-out Tag-out or LOTO for short.

Other Physical Hazards Module Isolate or isolation means the process by which employees in a confined space are completely protected against the release of energy and material into the space, and contact with a physical hazard, by such means as: blanking or blinding; misaligning or removing sections of lines, pipes, or ducts; a double block and bleed system; lockout or tagout of all sources of energy; blocking or disconnecting all mechanical linkages; or placement of barriers to eliminate the potential for employee contact with a physical hazard.

Typical Steps to Lockout Tagout Procedure

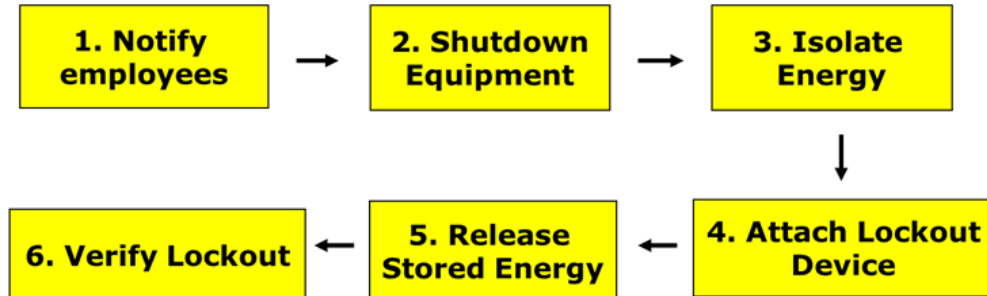

Typical Steps to Remove Lockout Tagout and Reenergize

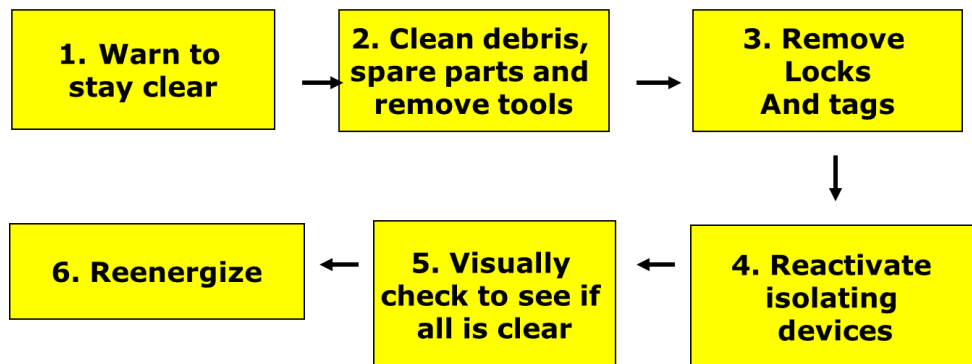

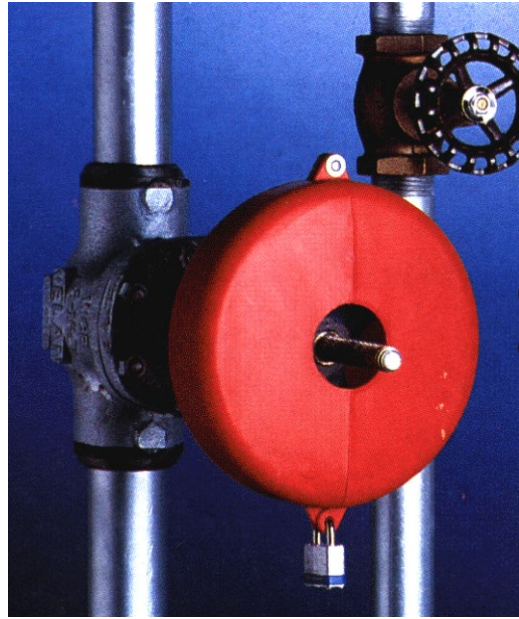

Examples of Isolation Devices

6. Oxidizing Agents Module

An oxidizing agent is a chemical substance that reacts with another chemical called the reactant and results in the removal electrons. This reaction is referred to as a redox chemical reaction and can in some oxidizers release a great deal of chemical energy, which has the potential to cause injury, illness and damage.

Common Oxidizing Agents

Oxygen (O₂)

Ozone (O₃)

Hydrogen peroxide (H₂O₂) and other inorganic peroxides

Fluorine (F₂), chlorine (Cl₂), and other halogens

Hexavalent chromium compounds such as chromic and dichromic acids and chromium trioxide, pyridinium chlorochromate (PCC), and chromate/dichromate compounds

Permanganate compounds such as KMnO₄

Sodium perborate

Nitric acid (HNO₃) and nitrate compounds

Sulfuric acid (H₂SO₄)

Peroxydisulfuric acid (H₂S₂O₈)

Peroxymonosulfuric acid (H₂SO₅)

Chlorite, chlorate, perchlorate, and other analogous halogen compounds

Hypochlorite and other hypohalite compounds, including household bleach (NaClO)

Nitrous oxide (N₂O)

Silver oxide (Ag₂O)

Osmium tetroxide (OsO₄)

7. Rescue Module

There are three types of rescues for a PRCS. Let's discuss the implications of rescue.

1. Self-Rescue
2. Non-Entry Rescue
3. Entry Rescue

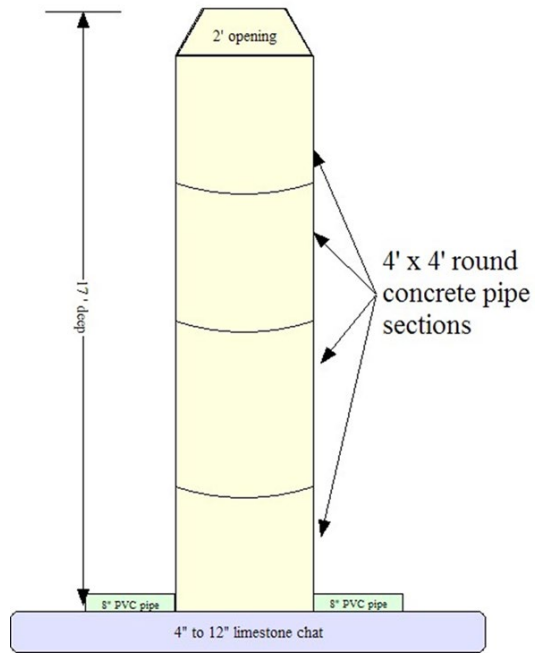

Vertical PRCS

1

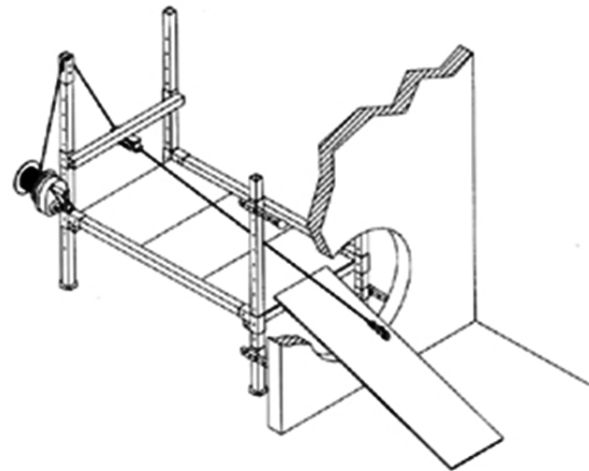

Horizontal PRCS

Section Four: The Checklist

Using checklists has become standard. Other critical industries have made aviation, healthcare, hospitals and other critical industries, managers have turned to utilizing checklists to ensure and hedge against human error. Sometimes there are just too many moving parts to remember so deliberate checklist help keep everyone on the right track.

Make a CHECKLIST based upon code and best practice

Communication and Coordination Checklist		Yes	No
1.	Has the host provided controlling contractor the location of the PRCS?	✓	
2.	Has the host provided controlling contractor with the specific nature of the hazard(s) within the PRCS?	✓	
3.	Has the host employer provided controlling contractor with precautions and controls previously utilized in the PRCS by other controlling and entry contractors?	✓	
4.	Has the host communicated and coordinated with controlling contractor on emergency action plan and provided facility orientation protocol?	✓	
5.	Has controlling contractor received, reviewed and consulted with host on above items 1 through 4?	✓	
6.	Has controlling contractor provided and reviewed the information from the host in items 1 through 4 with entry employer?	✓	
7.	Does the entry employer fully understand the information provided by the controlling contractor?	✓	
8.	Have all workers on site been trained to recognize and avoid permit confined spaces?	✓	
9.	Has a plan of communication during entry been established?	✓	
10.	Are there any barriers of communications between workers i.e. language, impairment etc.?		✓
11.	Have all workers been trained in recognition and avoidance of PRCS?	✓	
12.	Has a qualified rescue team been provided a briefing of facility, hazards and procedures?	✓	
13.	Has a bilateral debriefing between the controlling contractor and the entry employer taken place regarding the performance of the PRCS program followed and any hazards confronted or created in the permit space(s) during entry operations?	✓	
14.	Has the controlling contractor apprised the host employer of the information exchanged with the entry entities pursuant to this subparagraph?	✓	
15.	Has the host reviewed and archived debriefing notes and information within permit?	✓	

When we perform tasks as a matter of routine, such as completing a checklist day after day, sometimes we move too quickly, less deliberate than we should that can lead to making an error or overlooking something important. This is the reason why in a hospital before a surgery medical professionals will ask a series of the same questions often worded a bit differently. Notice the checklist above has one dissimilar answer. This checklist is developed that each of these questions must have the “correct answer” to help guide the applicant through code and best practice compliance. Yet the validating question, which is different from the others, tells us if the checklist was deliberately completed. If a checklist is use often enough, an employer may change the validating question, just to keep everyone on their toes since we tend to take shortcuts.



Thing People Do: College student takes shortcut off the campus planned path.

Make a CHECKLIST based upon code and best practice

This is a “validating” question because it can gauge if the person who performed the checklist paid close attention to each individual question. Atypical answers to validating questions may suggest further review. Employers can periodically shuffle the validating question so competent persons don’t become too comfortable with the format.

	Yes	No
1. Identification of the PRCS?	✓	
2. Specific nature of the hazard(s) within	✓	
3. with precautions and controls and entry contractors?	✓	
4. Controlling contractor on emergency	✓	
5. Consulted with host on above items 1	✓	
6. Information from the host in items 1	✓	
7. Does the entry employer fully understand the information provided by the controlling contractor?	✓	
8. Have all workers on site been trained to recognize and avoid permit confined spaces?	✓	
9. Has a plan of communication during entry been established?	✓	
10. Are there any barriers of communications between workers i.e. language, impairment etc.?		✓
11. Have all workers been trained in recognition and avoidance of PRCS?	✓	
12. Has a qualified rescue team been provided a briefing of facility, hazards and procedures?	✓	
13. Has a bilateral debriefing between the controlling contractor and the entry employer taken place regarding the performance of the PRCS program followed and any hazards confronted or created in the permit space(s) during entry operations?	✓	
14. Has the controlling contractor apprised the host employer of the information exchanged with the entry entities pursuant to this subparagraph	✓	
15. Has the host reviewed and archived debriefing notes and information within permit?	✓	

Section Five: Confined Spaces in Construction Group Exercise

Exercise Option 1:

1. Create your own permit required confined space. Congratulations! You just received a contract for the XYZ Company located in Queens, New York. Each group will act as a different entity in this exercise; the host employer, the controlling contractor, the entry employers, rescue team and others. As a group discuss a means of coordination from “your” perspective and plan a course of action.
2. Choose a PRCS and includes as many hazards as you wish; you can be creative here, this is an exercise.
3. Describe the communications that you will use not only for the entry by throughout the facility and beyond.
4. Describe what means you would use to ensure full coordination.
5. Describe the controls you will utilize and complete a Job Hazard Analysis
6. Describe your emergency action plan and rescue procedures.
7. Describe your debriefing procedures.

Exercise Option 2:

As a group, using the Confined Space Inventory and Checklist matrix below (page 39) try to anticipate other hazards in associated confined spaces throughout the XYZ Company facility. See too if some other construction activity your team may perform in the facility can create another NEW permit required confined space. Be creative with your scenarios.

Job Hazard/Safety Analysis Matrix

Task	Hazard	Control	Means of Implementation
Break tasks down to smaller sub-tasks.	List all possible associated hazards preferably in an order of severity	Use the Hierarchy of Controls 1. Elimination 2. Engineering 3. Mitigation	Should set out procedures that are easy to understand and accomplish in the field. Include the use equipment and requisite training and administrative

A job hazard analysis is a technique that focuses on job tasks as a way to identify hazards before they occur. It focuses on the relationship between the worker, the task, the tools, the work environment and the necessary steps to control a hazard. In a permit required confined space Job Hazard Analysis class to control hazards by eliminating them or engineering them away.

Job Hazard Analysis (JHA) for XYZ Company Queens New York				
#	Step/Task	Hazards	Control	Means of Implementation

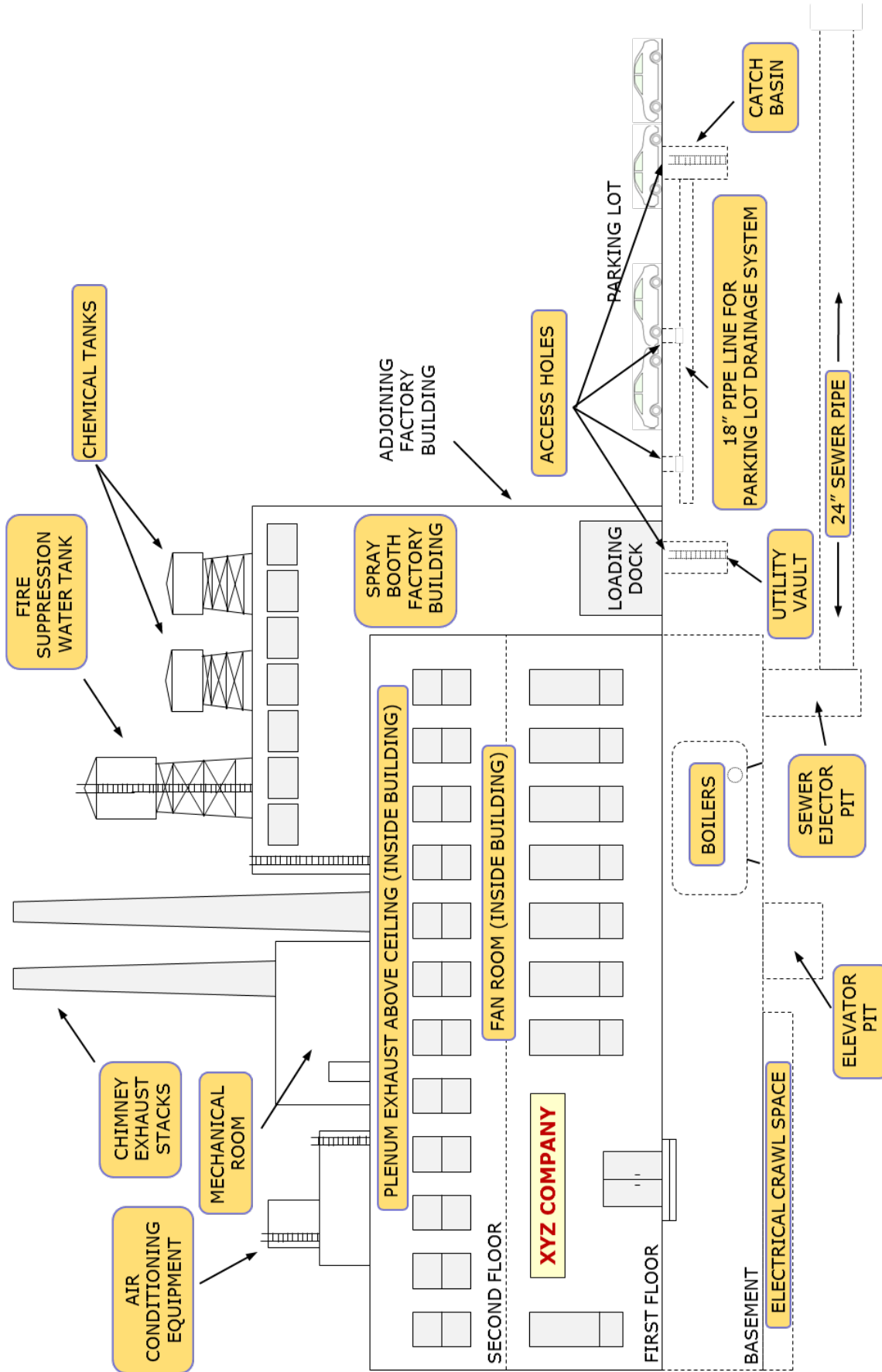

XYZ COMPANY CONFINED SPACE INVENTORY & CHECKLIST										
ID	Confined Space	Location	Permit Required		Employees Informed		Posted Signage		Associated Hazards	Competent Person
			Yes	No	Yes	No	Yes	No		
A	Access Holes	Parking lot	X		X		X		1. Engulfment 2. Hydrogen Sulfide 3. Atmospheric 4. Configuration 5. Health (biological) 6. Animals 7. Falls	John Doe, ABC Plumbing Phone (212) 555-5555 Email: JDOE@ABCPLUMBING.COM
B	Air Conditioning Equipment	Roof	X		X		X		1. Configuration 2. Electrical 3. Legionella 4. Falls 5. Atmospheric 6. Toxic (Cleaners)	Joe SMITH, LMN HVAC Phone (212) 111-1111 Email: Jsmith@LMNHVAC.COM
C	Boilers	Basement	X		X		X		1. Atmospheric (Rust) 2. Explosive 3. Extreme Heat 4. Configuration 5. Toxic (Muck)	John Doe, ABC Plumbing Phone (212) 555-5555 Email: JDOE@ABCPLUMBING.COM
D	Chemical Storage Tanks	Roof	X		X		X		1. Toxic (Chemicals) 2. Explosive 3. Falls 4. Atmospheric (Oxygen)	Tom Harry Smith, CHEMS R US Phone (212) 111-1111 Email: THS@CjemsRus..COM

XYZ COMPANY CONFINED SPACE INVENTORY & CHECKLIST										
ID	Confined Space	Location	Permit Required		Employees Informed		Posted Signage		Associated Hazards	Competent Person
			Yes	No	Yes	No	Yes	No		
E	Fire Suppression Water Tanks									
F	Elevator Pits									

XYZ COMPANY CONFINED SPACE INVENTORY & CHECKLIST										
ID	Confined Space	Location	Permit Required		Employees Informed		Posted Signage		Associated Hazards	Competent Person
			Yes	No	Yes	No	Yes	No		
I	Catch Basin									
J	Utility Vault									

XYZ COMPANY CONFINED SPACE INVENTORY & CHECKLIST										
ID	Confined Space	Location	Permit Required		Employees Informed		Posted Signage		Associated Hazards	Competent Person
			Yes	No	Yes	No	Yes	No		
G	Sewer Ejector Pit									
H	18" Pipe line									

XYZ COMPANY CONFINED SPACE INVENTORY & CHECKLIST

ID	Confined Space	Location	Permit Required		Employees Informed		Posted Signage		Associated Hazards	Competent Person
			Yes	No	Yes	No	Yes	No		
K	Electrical Crawl Space									
L	24 inch Sewer Pipe									

XYZ COMPANY CONFINED SPACE INVENTORY & CHECKLIST										
ID	Confined Space	Location	Permit Required		Employees Informed		Posted Signage		Associated Hazards	Competent Person
			Yes	No	Yes	No	Yes	No		
O	Ceiling Plenums									
?	Create a PRCS									

Appendix A: Subpart AA Confined Spaces in Construction

1926.1200	Reserved
1926.1201	Scope
1926.1202	Definitions
1926.1203	General requirements
1926.1204	Permit-required confined space program
1926.1205	Permitting process
1926.1206	Entry permit
1926.1207	Training
1926.1208	Duties of authorized entrants
1926.1209	Duties of attendants
1926.1210	Duties of entry supervisors
1926.1211	Rescue and emergency services
1926.1212	Employee participation
1926.1213	Provision of documents to Secretary

§1926.1201 Scope.

(a) This Standard sets forth requirements for practices and procedures to protect employees engaged in construction activities at a worksite with one or more confined spaces, subject to the exceptions in paragraph (b) of this section.

Note to paragraph §1926.1201(a). Examples of locations where confined spaces may occur include, but are not limited to, the following: Bins; boilers; pits (such as elevator, escalator, pump, valve or other equipment); manholes (such as sewer, storm drain, electrical, communication, or other utility); tanks (such as fuel, chemical, water, or other liquid, solid or gas); incinerators; scrubbers; concrete pier columns; sewers; transformer vaults; heating, ventilation, and air-conditioning (HVAC) ducts; storm drains; water mains; precast concrete and other pre-formed manhole units; drilled shafts; enclosed beams; vessels; digesters; lift stations;

cesspools; silos; air receivers; sludge gates; air preheaters; step up transformers; turbines; chillers; bag houses; and/or mixers/reactors.

(b) Exceptions. This Standard does not apply to: (1) Construction work regulated by §1926 subpart P—Excavations. (2) Construction work regulated by §1926 subpart S—Underground Construction, Caissons, Cofferdams and Compressed Air. (3) Construction work regulated by §1926 subpart Y—Diving.

(c) Where this Standard applies and there is a provision that addresses a confined space hazard in another applicable OSHA Standard, the employer must comply with both that requirement and the applicable provisions of this Standard.

§1926.1202 Definitions.

The following terms are defined for the purposes of this subpart only:

Acceptable entry conditions means the conditions that must exist in a permit space, before an employee may enter that space, to ensure that employees can safely enter into, and safely work within, the space.

Attendant means an individual stationed outside one or more permit spaces who assesses the status of authorized entrants and who must perform the duties specified in §1926.1209.

Authorized entrant means an employee who is authorized by the entry supervisor to enter a permit space.

Barrier means a physical obstruction that blocks or limits access.

Blanking or blinding means the absolute closure of a pipe, line, or duct by the fastening of a solid plate (such as a spectacle blind or a skillet blind) that completely covers the bore and that is capable of withstanding the maximum pressure of the pipe, line, or duct with no leakage beyond the plate.

Competent person means one who is capable of identifying existing and predictable hazards in the surroundings or working conditions which are unsanitary, hazardous, or dangerous to employees, and who has the authorization to take prompt corrective measures to eliminate them.

Confined space means a space that:

- (1) Is large enough and so configured that an employee can bodily enter it;
- (2) Has limited or restricted means for entry and exit; and
- (3) Is not designed for continuous employee occupancy.

Control means the action taken to reduce the level of any hazard inside a confined space using engineering methods (for example, by ventilation), and then using these methods to maintain the reduced hazard level. Control also refers to the engineering methods used for this purpose. Personal protective equipment is not a control.

Controlling Contractor is the employer that has overall responsibility for construction at the worksite.

Note. If the controlling contractor owns or manages the property, then it is both a controlling employer and a host employer.

Double block and bleed means the closure of a line, duct, or pipe by closing and locking or tagging two in-line valves and by opening and locking or tagging a drain or vent valve in the line between the two closed valves.

Early-warning system means the method used to alert authorized entrants and attendants that an engulfment hazard may be developing. Examples of early-warning systems include, but are not limited to: alarms activated by remote sensors; and lookouts with equipment for immediately communicating with the authorized entrants and attendants.

Emergency means any occurrence (including any failure of power, hazard control or monitoring equipment) or event, internal or external, to the permit space that could endanger entrants.

Engulfment means the surrounding and effective capture of a person by a liquid or finely divided (flowable) solid substance that can be aspirated to cause death by filling or plugging the respiratory system or that can exert enough force on the body to cause death by strangulation, constriction, crushing, or suffocation.

Entry means the action by which any part of a person passes through an opening into a permit-required confined space. Entry includes ensuing work activities in that space and is considered to have occurred as soon as any part of the entrant's body breaks the plane of an opening into the space, whether or not such action is intentional or any work activities are actually performed in the space.

Entry Employer means any employer who decides that an employee it directs will enter a permit space.

Note. An employer cannot avoid the duties of the Standard merely by refusing to decide whether its employees will enter a permit space, and OSHA will consider the failure to so decide to be an implicit decision to allow employees to enter those spaces if they are working in the proximity of the space.

Entry permit (permit) means the written or printed document that is provided by the employer who designated the space a permit space to allow and control entry into a permit space and that contains the information specified in §1926.1206 of this Standard.

Entry rescue occurs when a rescue service enters a permit space to rescue one or more employees.

Entry supervisor means the qualified person (such as the employer, foreman, or crew chief) responsible for determining if acceptable entry conditions are present at a permit space where entry is planned, for authorizing entry and overseeing entry operations, and for terminating entry as required by this Standard.

Note. An entry supervisor also may serve as an attendant or as an authorized entrant, as long as that person is trained and equipped as required by this Standard for each role he or she fills. Also, the duties of entry supervisor may be passed from one individual to another during the course of an entry operation.

Hazard means a physical hazard or hazardous atmosphere. See definitions below.

Hazardous atmosphere means an atmosphere that may expose employees to the risk of death, incapacitation, impairment of ability to self-rescue (that is, escape unaided from a permit space), injury, or acute illness from one or more of the following causes:

- (1) Flammable gas, vapor, or mist in excess of 10 percent of its lower flammable limit (LFL);
- (2) Airborne combustible dust at a concentration that meets or exceeds its LFL;

Note: This concentration may be approximated as a condition in which the combustible dust obscures vision at a distance of 5 feet (1.52 meters) or less.

- (3) Atmospheric oxygen concentration below 19.5 percent or above 23.5 percent;
- (4) Atmospheric concentration of any substance for which a dose or a permissible exposure limit is published in Subpart D—Occupational Health and Environmental Control, or in Subpart Z—Toxic and Hazardous Substances, of this part and which could result in employee exposure in excess of its dose or permissible exposure limit;

Note. An atmospheric concentration of any substance that is not capable of causing death, incapacitation, impairment of ability to self-rescue, injury, or acute illness due to its health effects is not covered by this definition.

- (5) Any other atmospheric condition that is immediately dangerous to life or health.

Note. For air contaminants for which OSHA has not determined a dose or permissible exposure limit, other sources of information, such as Safety Data Sheets that comply with the Hazard

Communication Standard, §1926.59 of this part, published information, and internal documents can provide guidance in establishing acceptable atmospheric conditions.

Host employer means the employer that owns or manages the property where the construction work is taking place.

Note. If the owner of the property on which the construction activity occurs has contracted with an entity for the general management of that property, and has transferred to that entity the information specified in §1203(h)(1), OSHA will treat the contracted management entity as the host employer for as long as that entity manages the property. Otherwise, OSHA will treat the owner of the property as the host employer. In no case will there be more than one host employer.

Hot work means operations capable of providing a source of ignition (for example, riveting, welding, cutting, burning, and heating).

Immediately dangerous to life or health (IDLH) means any condition that would interfere with an individual's ability to escape unaided from a permit space and that poses a threat to life or that would cause irreversible adverse health effects.

Note. Some materials—hydrogen fluoride gas and cadmium vapor, for example—may produce immediate transient effects that, even if severe, may pass without medical attention, but are followed by sudden, possibly fatal collapse 12-72 hours after exposure. The victim "feels normal" after recovery from transient effects until collapse. Such materials in hazardous quantities are considered to be "immediately" dangerous to life or health.

Inerting means displacing the atmosphere in a permit space by a noncombustible gas (such as nitrogen) to such an extent that the resulting atmosphere is noncombustible.

Note. This procedure produces an IDLH oxygen-deficient atmosphere.

Isolate or isolation means the process by which employees in a confined space are completely protected against the release of energy and material into the space, and contact with a physical hazard, by such means as: blanking or blinding; misaligning or removing sections of lines, pipes, or ducts; a double block and bleed system; lockout or tagout of all sources of energy; blocking or disconnecting all mechanical linkages; or placement of barriers to eliminate the potential for employee contact with a physical hazard.

Limited or restricted means for entry or exit means a condition that has a potential to impede an employee's movement into or out of a confined space. Such conditions include, but are not limited to, trip hazards, poor illumination, slippery floors, inclining surfaces and ladders.

Line breaking means the intentional opening of a pipe, line, or duct that is or has been carrying flammable, corrosive, or toxic material, an inert gas, or any fluid at a volume, pressure, or temperature capable of causing injury.

Lockout means the placement of a lockout device on an energy isolating device, in accordance with an established procedure, ensuring that the energy isolating device and the equipment being controlled cannot be operated until the lockout device is removed.

Lower _ flammable limit or lower explosive limit means the minimum concentration of a substance in air needed for an ignition source to cause a flame or explosion.

Monitor or monitoring means the process used to identify and evaluate the hazards after an authorized entrant enters the space. This is a process of checking for changes that is performed in a periodic or continuous manner after the completion of the initial testing or evaluation of that space.

Non-entry rescue occurs when a rescue service, usually the attendant, retrieves employees in a permit space without entering the permit space.

Non-permit confined space means a confined space that meets the definition of a confined space but does not meet the requirements for a permit-required confined space, as defined in this subpart.

Oxygen deficient atmosphere means an atmosphere containing less than 19.5 percent oxygen by volume.

Oxygen enriched atmosphere means an atmosphere containing more than 23.5 percent oxygen by volume.

Permit-required confined space (permit space) means a confined space that has one or more of the following characteristics: (1) Contains or has a potential to contain a hazardous atmosphere; (2) Contains a material that has the potential for engulfing an entrant; (3) Has an internal configuration such that an entrant could be trapped or asphyxiated by inwardly converging walls or by a floor which slopes downward and tapers to a smaller cross-section; or (4) Contains any other recognized serious safety or health hazard.

Permit-required confined space program (permit space program) means the employer's overall program for controlling, and, where appropriate, for protecting employees from, permit space hazards and for regulating employee entry into permit spaces.

Physical hazard means an existing or potential hazard that can cause death or serious physical damage. Examples include, but are not limited to: explosives (as defined by paragraph (n) of §1926.914, definition of "explosive"); mechanical, electrical, hydraulic and pneumatic energy; radiation; temperature extremes; engulfment; noise; and inwardly converging surfaces.

Physical hazard also includes chemicals that can cause death or serious physical damage through skin or eye contact (rather than through inhalation).

Prohibited condition means any condition in a permit space that is not allowed by the permit during the period when entry is authorized. A hazardous atmosphere is a prohibited condition unless the employer can demonstrate that personal protective equipment (PPE) will provide effective protection for each employee in the permit space and provides the appropriate PPE to each employee.

Qualified person means one who, by possession of a recognized degree, certificate, or professional standing, or who by extensive knowledge, training, and experience, has successfully demonstrated his ability to solve or resolve problems relating to the subject matter, the work, or the project.

Representative _permit space means a mock-up of a confined space that has entrance openings that are similar to, and is of similar size, configuration, and accessibility to, the permit space that authorized entrants enter.

Rescue means retrieving, and providing medical assistance to, one or more employees who are in a permit space.

Rescue service means the personnel designated to rescue employees from permit spaces.

Retrieval system means the equipment (including a retrieval line, chest or full body harness, wristlets or anklets, if appropriate, and a lifting device or anchor) used for non-entry rescue of persons from permit spaces.

Serious physical damage means an impairment or illness in which a body part is made functionally useless or is substantially reduced in efficiency. Such impairment or illness may be permanent or temporary and includes, but is not limited to, loss of consciousness, disorientation, or other immediate and substantial reduction in mental efficiency. Injuries involving such impairment would usually require treatment by a physician or other licensed health-care professional.

Tagout means:(1) Placement of a tagout device on a circuit or equipment that has been deenergized, in accordance with an established procedure, to indicate that the circuit or equipment being controlled may not be operated until the tagout device is removed; and (2) The employer ensures that (i) tagout provides equivalent protection to lockout, or (ii) that lockout is infeasible and the employer has relieved, disconnected, restrained and otherwise rendered safe stored (residual) energy.

Test or testing means the process by which the hazards that may confront entrants of a permit space are identified and evaluated. Testing includes specifying the tests that are to be performed in the permit space.

Note. Testing enables employers both to devise and implement adequate control measures for the protection of authorized entrants and to determine if acceptable entry conditions are present immediately prior to, and during, entry.

Ventilate or ventilation means controlling a hazardous atmosphere using continuous forced-air mechanical systems that meet the requirements of §1926.57—Ventilation.

§1926.1203 General requirements.

(a) Before it begins work at a worksite, each employer must ensure that a competent person identifies all confined spaces in which one or more of the employees it directs may work, and identifies each space that is a permit space, through consideration and evaluation of the elements of that space, including testing as necessary.

(b) If the workplace contains one or more permit spaces, the employer who identifies, or who receives notice of, a permit space must:

(1) Inform exposed employees by posting danger signs or by any other equally effective means, of the existence and location of, and the danger posed by, each permit space; and

Note to paragraph §1926.1203(b)(1). A sign reading “DANGER -- PERMIT- REQUIRED CONFINED SPACE, DO NOT ENTER” or using other similar language would satisfy the requirement for a sign.

(2) Inform, in a timely manner and in a manner other than posting, its employees’ authorized representatives and the controlling contractor of the existence and location of, and the danger posed by, each permit space.

(c) Each employer who identifies, or receives notice of, a permit space and has not authorized employees it directs to work in that space must take effective measures to prevent those employees from entering that permit space, in addition to complying with all other applicable requirements of this Standard.

(d) If any employer decides that employees it directs will enter a permit space, that employer must have a written permit space program that complies with §1926.1204 implemented at the construction site. The written program must be made available prior to and during entry operations for inspection by employees and their authorized representatives.

(e) An employer may use the alternate procedures specified in paragraph §1926.1203(e)(2) for entering a permit space only under the conditions set forth in paragraph §1926.1203(e)(1).

(1) An employer whose employees enter a permit space need not comply with §§1926.1204 through 1206 and §§1926.1208 through 1211, provided that all of the following conditions are met:

- (i) The employer can demonstrate that all physical hazards in the space are eliminated or isolated through engineering controls so that the only hazard posed by the permit space is an actual or potential hazardous atmosphere;
- (ii) The employer can demonstrate that continuous forced air ventilation alone is sufficient to maintain that permit space safe for entry, and that, in the event the ventilation system stops working, entrants can exit the space safely;
- (iii) The employer develops monitoring and inspection data that supports the demonstrations required by paragraphs §1926.1203(e)(1)(i) and §1926.1203(e)(1)(ii);
- (iv) If an initial entry of the permit space is necessary to obtain the data required by paragraph §1926.1203(e)(1)(iii), the entry is performed in compliance with §§1926.1204 through 1211 of this Standard;
- (v) The determinations and supporting data required by paragraphs §1926.1203(e)(1)(i), (e)(1)(ii), and (e)(1)(iii) are documented by the employer and are made available to each employee who enters the permit space under the terms of paragraph §1926.1203(e) or to that employee's authorized representative; and
- (vi) Entry into the permit space under the terms of paragraph §1926.1203(e)(1) is performed in accordance with the requirements of paragraph §1926.1203(e)(2).

Note to paragraph §1926.1203(e)(1). See paragraph §1926.1203(g) for reclassification of a permit space after all hazards within the space have been eliminated.

- (2) The following requirements apply to entry into permit spaces that meet the conditions set forth in paragraph §1926.1203(e)(1):
 - (i) Any conditions making it unsafe to remove an entrance cover must be eliminated before the cover is removed.
 - (ii) When entrance covers are removed, the opening must be immediately guarded by a railing, temporary cover, or other temporary barrier that will prevent an accidental fall through the opening and that will protect each employee working in the space from foreign objects entering the space.
 - (iii) Before an employee enters the space, the internal atmosphere must be tested, with a calibrated direct-reading instrument, for oxygen content, for flammable gases and vapors, and for potential toxic air contaminants, in that order. Any employee who enters the space, or that employee's authorized representative, must be provided an opportunity to observe the pre-entry testing required by this paragraph.

- (iv) No hazardous atmosphere is permitted within the space whenever any employee is inside the space.
- (v) Continuous forced air ventilation must be used, as follows:
 - (A) An employee must not enter the space until the forced air ventilation has eliminated any hazardous atmosphere;
 - (B) The forced air ventilation must be so directed as to ventilate the immediate areas where an employee is or will be present within the space and must continue until all employees have left the space;
 - (C) The air supply for the forced air ventilation must be from a clean source and must not increase the hazards in the space.
- (vi) The atmosphere within the space must be continuously monitored unless the entry employer can demonstrate that equipment for continuous monitoring is not commercially available or periodic monitoring is sufficient. If continuous monitoring is used, the employer must ensure that the monitoring equipment has an alarm that will notify all entrants if a specified atmospheric threshold is achieved, or that an employee will check the monitor with sufficient frequency to ensure that entrants have adequate time to escape. If continuous monitoring is not used, periodic monitoring is required. All monitoring must ensure that the continuous forced air ventilation is preventing the accumulation of a hazardous atmosphere. Any employee who enters the space, or that employee's authorized representative, must be provided with an opportunity to observe the testing required by this paragraph.
- (vii) If a hazard is detected during entry:
 - (A) Each employee must leave the space immediately;
 - (B) The space must be evaluated to determine how the hazard developed; and
 - (C) The employer must implement measures to protect employees from the hazard before any subsequent entry takes place.
- (viii) The employer must ensure a safe method of entering and exiting the space. If a hoisting system is used, it must be designed and manufactured for personnel hoisting; however, a job-made hoisting system is permissible if it is approved for personnel hoisting by a registered professional engineer, in writing, prior to use.
- (ix) The employer must verify that the space is safe for entry and that the pre-entry measures required by paragraph §1926.1203(e)(2) have been taken, through a written certification that contains the date, the location of the space, and the signature of the person

providing the certification. The certification must be made before entry and must be made available to each employee entering the space or to that employee's authorized representative.

(f) When there are changes in the use or configuration of a non-permit confined space that might increase the hazards to entrants, or some indication that the initial evaluation of the space may not have been adequate, each entry employer must have a competent person reevaluate that space and, if necessary, reclassify it as a permit- required confined space.

(g) A space classified by an employer as a permit-required confined space may only be reclassified as a non-permit confined space when a competent person determines that all of the applicable requirements in paragraphs §1926.1203(g)(1) through (g)(4) have been met:

(1) If the permit space poses no actual or potential atmospheric hazards and if all hazards within the space are eliminated or isolated without entry into the space (unless the employer can demonstrate that doing so without entry is infeasible), the permit space may be reclassified as a non-permit confined space for as long as the non-atmospheric hazards remain eliminated or isolated;

(2) The entry employer must eliminate or isolate the hazards without entering the space, unless it can demonstrate that this is infeasible. If it is necessary to enter the permit space to eliminate or isolate hazards, such entry must be performed under §§1926.1204 through 1211 of this Standard. If testing and inspection during that entry demonstrate that the hazards within the permit space have been eliminated or isolated, the permit space may be reclassified as a non-permit confined space for as long as the hazards remain eliminated or isolated;

Note to paragraph §1926.1203(g)(2). Control of atmospheric hazards through forced air ventilation does not constitute elimination or isolation of the hazards. Paragraph §1926.1203(e) covers permit space entry where the employer can demonstrate that forced air ventilation alone will control all hazards in the space.

(3) The entry employer must document the basis for determining that all hazards in a permit space have been eliminated or isolated, through a certification that contains the date, the location of the space, and the signature of the person making the determination. The certification must be made available to each employee entering the space or to that employee's authorized representative; and

(4) If hazards arise within a permit space that has been reclassified as a non-permit space under paragraph §1926.1203(g), each employee in the space must exit the space. The entry employer must then reevaluate the space and reclassify it as a permit space as appropriate in accordance with all other applicable provisions of this Standard.

(h) Permit Space Entry Communication and Coordination:

- (1) Before entry operations begin, the host employer must provide the following information, if it has it, to the controlling contractor:
 - (i) The location of each known permit space;
 - (ii) The hazards or potential hazards in each space or the reason it is a permit space; and
 - (iii) Any precautions that the host employer or any previous controlling contractor or entry employer implemented for the protection of employees in the permit space.
- (2) Before entry operations begin, the controlling contractor must:
 - (i) Obtain the host employer's information about the permit space hazards and previous entry operations; and
 - (ii) Provide the following information to each entity entering a permit space and any other entity at the worksite whose activities could foreseeably result in a hazard in the permit space:
 - (A) The information received from the host employer;
 - (B) Any additional information the controlling contractor has about the subjects listed in paragraph (h)(1) of this section; and
 - (C) The precautions that the host employer, controlling contractor, or other entry employers implemented for the protection of employees in the permit spaces.
- (3) Before entry operations begin, each entry employer must:
 - (i) Obtain all of the controlling contractor's information regarding permit space hazards and entry operations; and
 - (ii) Inform the controlling contractor of the permit space program that the entry employer will follow, including any hazards likely to be confronted or created in each permit space.
- (4) The controlling contractor and entry employer(s) must coordinate entry operations when:
 - (i) More than one entity performs permit space entry at the same time; or
 - (ii) Permit space entry is performed at the same time that any activities that could foreseeably result in a hazard in the permit space are performed.
- (5) After entry operations:
 - (i) The controlling contractor must debrief each entity that entered a permit space regarding the permit space program followed and any hazards confronted or created in the permit space(s) during entry operations;

(ii) The entry employer must inform the controlling contractor in a timely manner of the permit space program followed and of any hazards confronted or created in the permit space(s) during entry operations; and

(iii) The controlling contractor must apprise the host employer of the information exchanged with the entry entities pursuant to this subparagraph.

Note to paragraph §1926.1203(h). Unless a host employer or controlling contractor has or will have employees in a confined space, it is not required to enter any confined space to collect the information specified in this paragraph (h).

(iv) If there is no controlling contractor present at the worksite, the requirements for, and role of, controlling contractors in §1926.1203 must be fulfilled by the host employer or other employer who arranges to have employees of another employer perform work that involves permit space entry.

§1926.1204 Permit-Required Confined Space Program.

Each entry employer must:

- (a) Implement the measures necessary to prevent unauthorized entry;
- (b) Identify and evaluate the hazards of permit spaces before employees enter them;
- (c) Develop and implement the means, procedures, and practices necessary for safe permit space entry operations, including, but not limited to, the following:
 - (1) Specifying acceptable entry conditions;
 - (2) Providing each authorized entrant or that employee's authorized representative with the opportunity to observe any monitoring or testing of permit spaces;
 - (3) Isolating the permit space and physical hazard(s) within the space;
 - (4) Purging, inerting, flushing, or ventilating the permit space as necessary to eliminate or control atmospheric hazards;

Note to paragraph §1204(c)(4). When an employer is unable to reduce the atmosphere below 10 percent LFL, the employer may only enter if the employer inertes the space so as to render the entire atmosphere in the space noncombustible, and the employees use PPE to address any other atmospheric hazards (such as oxygen deficiency), and the employer eliminates or isolates all physical hazards in the space.

- (5) Determining that, in the event the ventilation system stops working, the monitoring procedures will detect an increase in atmospheric hazard levels in sufficient time for the entrants to safely exit the permit space;
 - (6) Providing pedestrian, vehicle, or other barriers as necessary to protect entrants from external hazards;
 - (7) Verifying that conditions in the permit space are acceptable for entry throughout the duration of an authorized entry, and ensuring that employees are not allowed to enter into, or remain in, a permit space with a hazardous atmosphere unless the employer can demonstrate that personal protective equipment (PPE) will provide effective protection for each employee in the permit space and provides the appropriate PPE to each employee; and
 - (8) Eliminating any conditions (for example, high pressure) that could make it unsafe to remove an entrance cover.
- (d) Provide the following equipment (specified in paragraphs §1926.1204(d)(1) through (d) (9)) at no cost to each employee, maintain that equipment properly, and ensure that each employee uses that equipment properly:
- (1) Testing and monitoring equipment needed to comply with paragraph §1926.1204(e);
 - (2) Ventilating equipment needed to obtain acceptable entry conditions;
 - (3) Communications equipment necessary for compliance with paragraphs §1926.1208(c) and §1926.1209(e), including any necessary electronic communication equipment for attendants assessing entrants' status in multiple spaces;
 - (4) Personal protective equipment insofar as feasible engineering and work-practice controls do not adequately protect employees;

Note to paragraph §1926.1204(d)(4). The requirements of subpart E of this part and other PPE requirements continue to apply to the use of PPE in a permit space. For example, if employees use respirators, then the respirator requirements in §1926.103 (Respiratory protection) must be met.

- (5) Lighting equipment that meets the minimum illumination requirements in §1926.56, that is approved for the ignitable or combustible properties of the specific gas, vapor, dust, or fiber that will be present, and that is sufficient to enable employees to see well enough to work safely and to exit the space quickly in an emergency;
- (6) Barriers and shields as required by paragraph §1926.1204(c)(4);
- (7) Equipment, such as ladders, needed for safe ingress and egress by authorized entrants;

- (8) Rescue and emergency equipment needed to comply with paragraph §1926.1204(i), except to the extent that the equipment is provided by rescue services; and
- (9) Any other equipment necessary for safe entry into, safe exit from, and rescue from, permit spaces.
- (e) Evaluate permit space conditions in accordance with the following paragraphs (e)(1) through (6) of this section when entry operations are conducted:
 - (1) Test conditions in the permit space to determine if acceptable entry conditions exist before changes to the space's natural ventilation are made, and before entry is authorized to begin, except that, if an employer demonstrates that isolation of the space is infeasible because the space is large or is part of a continuous system (such as a sewer), the employer must:
 - (i) Perform pre-entry testing to the extent feasible before entry is authorized; and,
 - (ii) If entry is authorized, continuously monitor entry conditions in the areas where authorized entrants are working, except that employers may use periodic monitoring in accordance with paragraph §1926.1204(e)(2) for monitoring an atmospheric hazard if they can demonstrate that equipment for continuously monitoring that hazard is not commercially available;
 - (iii) Provide an early-warning system that continuously monitors for non-isolated engulfment hazards. The system must alert authorized entrants and attendants in sufficient time for the authorized entrants to safely exit the space.
 - (2) Continuously monitor atmospheric hazards unless the employer can demonstrate that the equipment for continuously monitoring a hazard is not commercially available or that periodic monitoring is of sufficient frequency to ensure that the atmospheric hazard is being controlled at safe levels. If continuous monitoring is not used, periodic monitoring is required with sufficient frequency to ensure that acceptable entry conditions are being maintained during the course of entry operations;
 - (3) When testing for atmospheric hazards, test first for oxygen, then for combustible gases and vapors, and then for toxic gases and vapors;
 - (4) Provide each authorized entrant or that employee's authorized representative an opportunity to observe the pre-entry and any subsequent testing or monitoring of permit spaces;
 - (5) Reevaluate the permit space in the presence of any authorized entrant or that employee's authorized representative who requests that the employer conduct such reevaluation because there is some indication that the evaluation of that space may not have been adequate; and

- (6) Immediately provide each authorized entrant or that employee's authorized representative with the results of any testing conducted in accordance with §1926.1204 of this Standard.
- (f) Provide at least one attendant outside the permit space into which entry is authorized for the duration of entry operations;
 - (1) Attendants may be assigned to more than one permit space provided the duties described in §1926.1209 of this Standard can be effectively performed for each permit space.
 - (2) Attendants may be stationed at any location outside the permit space as long as the duties described in §1926.1209 of this Standard can be effectively performed for each permit space to which the attendant is assigned.
- (g) If multiple spaces are to be assigned to a single attendant, include in the permit program the means and procedures to enable the attendant to respond to an emergency affecting one or more of those permit spaces without distraction from the attendant's responsibilities under §1926.1209 of this Standard;
- (h) Designate each person who is to have an active role (as, for example, authorized entrants, attendants, entry supervisors, or persons who test or monitor the atmosphere in a permit space) in entry operations, identify the duties of each such employee, and provide each such employee with the training required by §1926.1207 of this Standard;
- (i) Develop and implement procedures for summoning rescue and emergency services (including procedures for summoning emergency assistance in the event of a failed non-entry rescue), for rescuing entrants from permit spaces, for providing necessary emergency services to rescued employees, and for preventing unauthorized personnel from attempting a rescue;
- (j) Develop and implement a system for the preparation, issuance, use, and cancellation of entry permits as required by this Standard, including the safe termination of entry operations under both planned and emergency conditions;
- (k) Develop and implement procedures to coordinate entry operations, in consultation with the controlling contractor, when employees of more than one employer are working simultaneously in a permit space or elsewhere on the worksite where their activities could, either alone or in conjunction with the activities within a permit space, foreseeably result in a hazard within the confined space, so that employees of one employer do not endanger the employees of any other employer;
- (l) Develop and implement procedures (such as closing off a permit space and canceling the permit) necessary for concluding the entry after entry operations have been completed;

(m) Review entry operations when the measures taken under the permit space program may not protect employees and revise the program to correct deficiencies found to exist before subsequent entries are authorized; and the occurrence of an injury or near-miss during entry, a change in the use or configuration of a permit space, and employee complaints about the effectiveness of the program.

(n) Review the permit space program, using the canceled permits retained under paragraph §1926.1205(f), within 1 year after each entry and revise the program as necessary to ensure that employees participating in entry operations are protected from permit space hazards.

Note to paragraph §1926.1204(m). Examples of circumstances requiring the review of the permit space program include, but are not limited to: any unauthorized entry of a permit space, the detection of a permit space hazard not covered by the permit, the detection of a condition prohibited by the permit,

Note to paragraph §1926.1204(n). Employers may perform a single annual review covering all entries performed during a 12-month period. If no entry is performed during a 12-month period, no review is necessary.

§1926.1205 Permitting Process.

(a) Before entry is authorized, each entry employer must document the completion of measures required by paragraph §1926.1204(c) of this Standard by preparing an entry permit.

(b) Before entry begins, the entry supervisor identified on the permit must sign the entry permit to authorize entry.

(c) The completed permit must be made available at the time of entry to all authorized entrants or their authorized representatives, by posting it at the entry portal or by any other equally effective means, so that the entrants can confirm that pre-entry preparations have been completed.

(d) The duration of the permit may not exceed the time required to complete the assigned task or job identified on the permit in accordance with paragraph §1926.1206(b) of this Standard.

(e) The entry supervisor must terminate entry and take the following action when any of the following apply:

(1) Cancel the entry permit when the entry operations covered by the entry permit have been completed; or

(2) Suspend or cancel the entry permit and fully reassess the space before allowing reentry when a condition that is not allowed under the entry permit arises in or near the permit space

and that condition is temporary in nature and does not change the configuration of the space or create any new hazards within it; and

(3) Cancel the entry permit when a condition that is not allowed under the entry permit arises in or near the permit space and that condition is not covered by subparagraph (e)(2) of this section.

(f) The entry employer must retain each canceled entry permit for at least 1 year to facilitate the review of the permit-required confined space program required by paragraph §1926.1204(n) of this Standard. Any problems encountered during an entry operation must be noted on the pertinent permit so that appropriate revisions to the permit space program can be made.

§1926.1206 Entry permit.

The entry permit that documents compliance with this section and authorizes entry to a permit space must identify:

- (a) The permit space to be entered;
- (b) The purpose of the entry;
- (c) The date and the authorized duration of the entry permit;
- (d) The authorized entrants within the permit space, by name or by such other means (for example, through the use of rosters or tracking systems) as will enable the attendant to determine quickly and accurately, for the duration of the permit, which authorized entrants are inside the permit space;

Note to paragraph §1926.1206(d). This requirement may be met by inserting a reference on the entry permit as to the means used, such as a roster or tracking system, to keep track of the authorized entrants within the permit space.

- (e) Means of detecting an increase in atmospheric hazard levels in the event the ventilation system stops working;
- (f) Each person, by name, currently serving as an attendant;
- (g) The individual, by name, currently serving as entry supervisor, and the signature or initials of each entry supervisor who authorizes entry;
- (h) The hazards of the permit space to be entered;
- (i) The measures used to isolate the permit space and to eliminate or control permit space hazards before entry;

Note to paragraph §1926.1206(i). Those measures can include, but are not limited to, the lockout or tagging of equipment and procedures for purging, inerting, ventilating, and flushing permit spaces.

- (j) The acceptable entry conditions;
- (k) The results of tests and monitoring performed under paragraph §1926.1204(e) of this Standard, accompanied by the names or initials of the testers and by an indication of when the tests were performed;
- (l) The rescue and emergency services that can be summoned and the means (such as the equipment to use and the numbers to call) for summoning those services;
- (m) The communication procedures used by authorized entrants and attendants to maintain contact during the entry;
- (n) Equipment, such as personal protective equipment, testing equipment, communications equipment, alarm systems, and rescue equipment, to be provided for compliance with this Standard;
- (o) Any other information necessary, given the circumstances of the particular confined space, to ensure employee safety; and
- (p) Any additional permits, such as for hot work, that have been issued to authorize work in the permit space.

§1926.1207 Training.

- (a) The employer must provide training to each employee whose work is regulated by this Standard, at no cost to the employee, and ensure that the employee possesses the understanding, knowledge, and skills necessary for the safe performance of the duties assigned under this Standard. This training must result in an understanding of the hazards in the permit space and the methods used to isolate, control or in other ways protect employees from these hazards, and for those employees not authorized to perform entry rescues, in the dangers of attempting such rescues.
 - (b) Training required by this section must be provided to each affected employee:
 - (1) In both a language and vocabulary that the employee can understand;
 - (2) Before the employee is first assigned duties under this Standard;
 - (3) Before there is a change in assigned duties;

(4) Whenever there is a change in permit space entry operations that presents a hazard about which an employee has not previously been trained; and

(5) Whenever there is any evidence of a deviation from the permit space entry procedures required by paragraph §1926.1204(c) of this Standard or there are inadequacies in the employee's knowledge or use of these procedures.

(c) The training must establish employee proficiency in the duties required by this Standard and must introduce new or revised procedures, as necessary, for compliance with this Standard.

(d) The employer must maintain training records to show that the training required by paragraphs §1926.1207(a) through (c) of this Standard has been accomplished. The training records must contain each employee's name, the name of the trainers, and the dates of training. The documentation must be available for inspection by employees and their authorized representatives, for the period of time the employee is employed by that employer.

§1926.1208 Duties of authorized entrants.

The entry employer must ensure that all authorized entrants:

(a) Are familiar with and understand the hazards that may be faced during entry, including information on the mode, signs or symptoms, and consequences of the exposure;

(b) Properly use equipment as required by paragraph §1926.1204(d) of this Standard;

(c) Communicate with the attendant as necessary to enable the attendant to assess entrant status and to enable the attendant to alert entrants of the need to evacuate the space as required by paragraph §1926.1209(f) of this Standard;

(d) Alert the attendant whenever:

(1) There is any warning sign or symptom of exposure to a dangerous situation; or

(2) The entrant detects a prohibited condition; and

(e) Exit from the permit space as quickly as possible whenever:

(1) An order to evacuate is given by the attendant or the entry supervisor;

(2) There is any warning sign or symptom of exposure to a dangerous situation;

(3) The entrant detects a prohibited condition; or

(4) An evacuation alarm is activated.

§1926.1209 Duties of attendants.

The entry employer must ensure that each attendant:

- (a) Is familiar with and understands the hazards that may be faced during entry, including information on the mode, signs or symptoms, and consequences of the exposure;
- (b) Is aware of possible behavioral effects of hazard exposure in authorized entrants;
- (c) Continuously maintains an accurate count of authorized entrants in the permit space and ensures that the means used to identify authorized entrants under paragraph 1926.1206(d) of this Standard accurately identifies who is in the permit space;
- (d) Remains outside the permit space during entry operations until relieved by another attendant;

Note to paragraph §1926.1209(d). Once an attendant has been relieved by another attendant, the relieved attendant may enter a permit space to attempt a rescue when the employer's permit space program allows attendant entry for rescue and the attendant has been trained and equipped for rescue operations as required by paragraph §1926.1211(a).

- (e) Communicates with authorized entrants as necessary to assess entrant status and to alert entrants of the need to evacuate the space under paragraph §1926.1208(e);
- (f) Assesses activities and conditions inside and outside the space to determine if it is safe for entrants to remain in the space and orders the authorized entrants to evacuate the permit space immediately under any of the following conditions:
 - (1) If there is a prohibited condition;
 - (2) If the behavioral effects of hazard exposure are apparent in an authorized entrant;
 - (3) If there is a situation outside the space that could endanger the authorized entrants; or
 - (4) If the attendant cannot effectively and safely perform all the duties required under §1926.1209 of this Standard;
- (g) Summons rescue and other emergency services as soon as the attendant determines that authorized entrants may need assistance to escape from permit space hazards;
- (h) Takes the following actions when unauthorized persons approach or enter a permit space while entry is underway:
 - (1) Warns the unauthorized persons that they must stay away from the permit space;
 - (2) Advises the unauthorized persons that they must exit immediately if they have entered the permit space; and

(3) Informs the authorized entrants and the entry supervisor if unauthorized persons have entered the permit space;

(i) Performs non-entry rescues as specified by the employer's rescue procedure; and

(j) Performs no duties that might interfere with the attendant's primary duty to assess and protect the authorized entrants.

§1926.1210 Duties of entry supervisors.

The entry employer must ensure that each entry supervisor:

(a) Is familiar with and understands the hazards that may be faced during entry, including information on the mode, signs or symptoms, and consequences of the exposure;

(b) Verifies, by checking that the appropriate entries have been made on the permit, that all tests specified by the permit have been conducted and that all procedures and equipment specified by the permit are in place before endorsing the permit and allowing entry to begin;

(c) Terminates the entry and cancels or suspends the permit as required by paragraph 1926.1205(e) of this Standard;

(d) Verifies that rescue services are available and that the means for summoning them are operable, and that the employer will be notified as soon as the services become unavailable;

(e) Removes unauthorized individuals who enter or who attempt to enter the permit space during entry operations; and

(f) Determines, whenever responsibility for a permit space entry operation is transferred, and at intervals dictated by the hazards and operations performed within the space, that entry operations remain consistent with terms of the entry permit and that acceptable entry conditions are maintained.

§1926.1211 Rescue and emergency services.

(a) An employer who designates rescue and emergency services, pursuant to paragraph §1926.1204(i) of this Standard, must:

(1) Evaluate a prospective rescuer's ability to respond to a rescue summons in a timely manner, considering the hazard(s) identified;

Note to paragraph §1926.1211(a)(1). What will be considered timely will vary according to the specific hazards involved in each entry. For example,

§1926.103—Respiratory Protection requires that employers provide a standby person or persons capable of immediate action to rescue employee(s) wearing respiratory protection while in work areas defined as IDLH atmospheres.

- (2) Evaluate a prospective rescue service's ability, in terms of proficiency with rescue-related tasks and equipment, to function appropriately while rescuing entrants from the particular permit space or types of permit spaces identified;
 - (3) Select a rescue team or service from those evaluated that:
 - (i) Has the capability to reach the victim(s) within a time frame that is appropriate for the permit space hazard(s) identified;
 - (ii) Is equipped for, and proficient in, performing the needed rescue services;
 - (iii) Agrees to notify the employer immediately in the event that the rescue service becomes unavailable;
 - (4) Inform each rescue team or service of the hazards they may confront when called on to perform rescue at the site; and
 - (5) Provide the rescue team or service selected with access to all permit spaces from which rescue may be necessary so that the rescue team or service can develop appropriate rescue plans and practice rescue operations.
- (b) An employer whose employees have been designated to provide permit space rescue and/or emergency services must take the following measures and provide all equipment and training at no cost to those employees:
- (1) Provide each affected employee with the personal protective equipment (PPE) needed to conduct permit space rescues safely and train each affected employee so the employee is proficient in the use of that PPE;
 - (2) Train each affected employee to perform assigned rescue duties. The employer must ensure that such employees successfully complete the training required and establish proficiency as authorized entrants, as provided by §§1926.1207 and 1926.1208 of this Standard;
 - (3) Train each affected employee in basic first aid and cardiopulmonary resuscitation (CPR). The employer must ensure that at least one member of the rescue team or service holding a current certification in basic first aid and CPR is available; and
 - (4) Ensure that affected employees practice making permit space rescues before attempting an actual rescue, and at least once every 12 months, by means of simulated rescue operations in which they remove dummies, manikins, or actual persons from the actual permit

spaces or from representative permit spaces, except practice rescue is not required where the affected employees properly performed a rescue operation during the last 12 months in the same permit space the authorized entrant will enter, or in a similar permit space.

Representative permit spaces must, with respect to opening size, configuration, and accessibility, simulate the types of permit spaces from which rescue is to be performed.

(c) Non-entry rescue is required unless the retrieval equipment would increase the overall risk of entry or would not contribute to the rescue of the entrant. The employer must designate an entry rescue service whenever non-entry rescue is not selected. Whenever non-entry rescue is selected, the entry employer must ensure that retrieval systems or methods are used whenever an authorized entrant enters a permit space, and must confirm, prior to entry, that emergency assistance would be available in the event that non-entry rescue fails. Retrieval systems must meet the following requirements:

(1) Each authorized entrant must use a chest or full body harness, with a retrieval line attached at the center of the entrant's back near shoulder level, above the entrant's head, or at another point which the employer can establish presents a profile small enough for the successful removal of the entrant. Wristlets or anklets may be used in lieu of the chest or full body harness if the employer can demonstrate that the use of a chest or full body harness is infeasible or creates a greater hazard and that the use of wristlets or anklets is the safest and most effective alternative.

(2) The other end of the retrieval line must be attached to a mechanical device or fixed point outside the permit space in such a manner that rescue can begin as soon as the rescuer becomes aware that rescue is necessary. A mechanical device must be available to retrieve personnel from vertical type permit spaces more than 5 feet (1.52 meters) deep.

(3) Equipment that is unsuitable for retrieval must not be used, including, but not limited to, retrieval lines that have a reasonable probability of becoming entangled with the retrieval lines used by other authorized entrants, or retrieval lines that will not work due to the internal configuration of the permit space.

(d) If an injured entrant is exposed to a substance for which a Safety Data Sheet (SDS) or other similar written information is required to be kept at the worksite, that SDS or written information must be made available to the medical facility treating the exposed entrant.

§1926.1212 Employee participation.

(a) Employers must consult with affected employees and their authorized representatives on the development and implementation of all aspects of the permit space program required by §1926.1203 of this Standard.

(b) Employers must make available to each affected employee and his/her authorized representatives all information required to be developed by this Standard.

§1926.1213 Provision of documents to Secretary.

For each document required to be retained in this Standard, the retaining employer must make the document available on request to the Secretary of Labor or the Secretary's designee.

Appendix B: Sample SDS

Appendix C: Confined Space Basics

Question: What is a Confined Space?

Answer: A confined space means a space that:

- (1) Is large enough and so configured that an employee can bodily enter it;**
- (2) Has limited or restricted means for entry and exit; and**
- (3) Is not designed for continuous employee occupancy.**

Examples of typical Confined Spaces:



Pipes and pipelines

Possible Hazards:

Engulfment

Atmospheric

Configuration



Attics

Possible Hazards:

Extreme Temperature

Configuration

Electrical

Falls

Animals

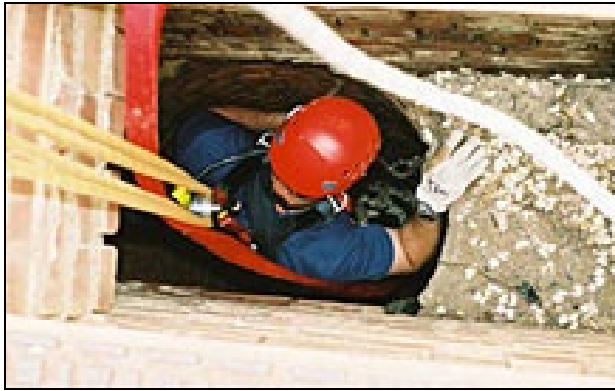

Vaults

Possible Hazards:

- Engulfment**
- Atmospheric**
- Configuration**
- Electrical**
- Explosion**
- Stored Energy**
- Struck-by**



Crawspaces and Ducts

Possible Hazards:

- Configuration**
- Atmospheric**
- Electrical**
- Animals**
- Engulfment**

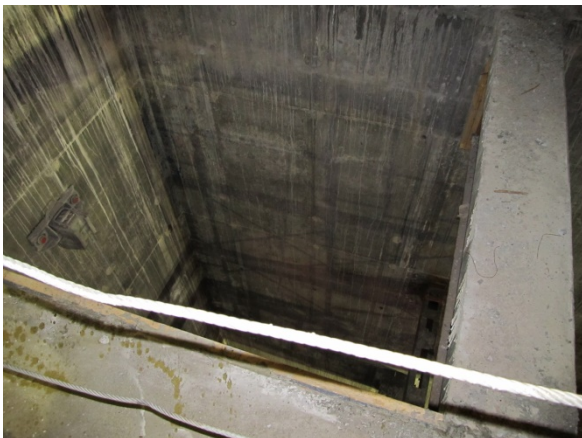

Pits and Shafts

Possible Hazards:

- Engulfment**
- Atmospheric**
- Struck-by**
- Electrical**
- Explosion**
- Stored Energy**
- Falls**



Manholes

Possible Hazards:

- Configuration**
- Atmospheric**
- Electrical**
- Engulfment**
- Stored Energy**
- Struck-by**
- Falls**



Tanks Vessel

Possible Hazards:

Engulfment

Atmospheric

Explosion

Stored Energy



Concrete Mixers

Possible Hazards:

Configuration

Atmospheric

Stored Energy

Configuration

Question: In a permit required confined space, what is a hazard?

Answer: A hazard in permit required confined space means a physical hazard or hazardous atmosphere:

Question: What is a physical hazard?

Answer: A physical hazard means an existing or potential hazard that can cause death or serious physical damage. Examples include, but are not limited to: explosives (as defined by paragraph (n) of §1926.914, definition of “explosive”); mechanical, electrical, hydraulic and pneumatic energy; radiation; temperature extremes; engulfment; noise; and inwardly converging surfaces. Physical hazard also includes chemicals that can cause death or serious physical damage through skin or eye contact (rather than through inhalation).

Question: What is a Hazardous Atmosphere?

Answer: A Hazardous atmosphere means an atmosphere that may expose employees to the risk of death, incapacitation, impairment of ability to self-rescue (that is, escape unaided from a permit space), injury, or acute illness from one or more of the following causes:

(1) Flammable gas, vapor, or mist in excess of 10 percent of its lower flammable limit (LFL);

- (2) Airborne combustible dust at a concentration that meets or exceeds its LFL;
- (3) Atmospheric oxygen concentration below 19.5 percent or above 23.5 percent;
- (4) Atmospheric concentration of any substance for which a dose or a permissible exposure limit is published in Subpart D—Occupational Health and Environmental Control, or in Subpart Z—Toxic and Hazardous Substances, of this part and which could result in employee exposure in excess of its dose or permissible exposure limit;

Note. An atmospheric concentration of any substance that is not capable of causing death, incapacitation, impairment of ability to self-rescue, injury, or acute illness due to its health effects is not covered by this definition.

- (5) Any other atmospheric condition that is immediately dangerous to life or health.
- Host employer means the employer that owns or manages the property where the construction work is taking place.

Examples of Permit Required Confined Space Hazards:



Physical: Hazards include moving parts and uncontrolled energy.



Physical: Hazards exposed electrical



Physical: Paint mixing/spray booths/chemicals



Atmospheric: Hazards may include a toxic or flammable atmosphere or an atmosphere that is oxygen enriched or oxygen deficient.

Question: What is a permit required confined space?

Answer: A permit-required confined space (permit space) means a confined space that has one or more of the following characteristics:

- (1) Contains or has a potential to contain a hazardous atmosphere;**

- (2) Contains a material that has the potential for engulfing an entrant;
- (3) Has an internal configuration such that an entrant could be trapped or asphyxiated by inwardly converging walls or by a floor which slopes downward and tapers to a smaller cross-section; or
- (4) Contains any other recognized serious safety or health hazard.

Physical hazard means an existing or potential hazard that can cause death or serious physical damage. Examples include, but are not limited to: explosives (as defined by paragraph (n) of §1926.914, definition of “explosive”); mechanical, electrical, hydraulic and pneumatic energy; radiation; temperature extremes; engulfment; noise; and inwardly converging surfaces. Physical hazard also includes chemicals that can cause death or serious physical damage through skin or eye contact (rather than through inhalation).

