

PLASTIC BOTTLE CORPORATION

28055 North Ashley Circle, Suite 110
Libertyville, IL 60048 9635
847 367 1900
fax: 847 367 1990
www.plasticbottle.com

Mission Statement

Plastic Bottle Corporation:

- ✓ Strives to be the premier company that customers look to for responsiveness and attentive service.
- ✓ Provides you with the solutions you need to get your products to market.
- ✓ Is poised to service both large and small customers.
- ✓ Takes pride in the level of personal service that your technically-trained staff provides.
- ✓ Continually expands our variety and selection.

Where great ideas take shape.

PLASTIC BOTTLE CORPORATION

28055 North Ashley Circle
Libertyville, IL 60048-9459

847-367-1900
Fax: 847-367-1990

Founded in 1981, Plastic Bottle Corporation has become a leading supplier of plastic bottles and jugs, all of which are produced in North America.

Plastic Bottle Corporation specializes in containers ranging from 1 oz to 10 Liter and we are always designing and building new molds to add to our stock product line. We also produce custom and private molds to meet our customers' specific requirements. Be it personal, household, automotive, lawn, pet care or other markets, we can help!

To those of you who are already customers of ours, we thank you. For those of you who have not worked with us yet, the next time that you're looking for something better, different or unique, contact us! We look forward to assisting you with your specialized packaging requirements.



Stuart Feen / President

INDEX

Size	Neck	Material	Description	Page #
1 oz	24-410	HDPE / LDPE	Boston Round	9.00
1 oz	33-400	HDPE	Wide Mouth Packer Round	53.50
1 oz	20-410	PVC / PETG	Straight Sided Cylinder	62.00
1 oz	24-410	PVC / PETG	Straight Sided Cylinder	62.00
30 cc	33-400	HDPE	Wide Mouth Packer Round	53.50
40/45 cc	33-400	HDPE	Tablet Round	53.75
40/45 cc	33mm Line Up Arrow	HDPE	Tablet Round	54.00
1.7 oz	24-410	HDPE	Pocket Oval	80.80
2 oz	18-415	PVC	Bullet Top Boston Round	1.00
2 oz	20-410	PVC	Bullet Top Boston Round	1.00
2 oz	20-415	PVC	Bullet Top Boston Round	1.00
2 oz	24-410	HDPE / LDPE	Bullet Top Boston Round	3.50
2 oz	20-410	OPET	Bullet Top Boston Round	6.00
2 oz	20-415	OPET	Bullet Top Boston Round	6.00
2 oz	24-410	OPET	Footed Bullet Top Boston Round	6.75
2 oz	20-415	PVC	Boston Round	7.00
2 oz	20-415	PVC	Philly Round	12.00
2 oz	20-410	HDPE	Bella Round	18.00
2 oz	20-410	HDPE	TK Round	22.00
2 oz	22-415	HDPE	TK Round	22.00
2 oz	Special Neck	HDPE	Fleur de lis Tottle	74.15
2 oz	20-410	PVC	Faceted Oval	75.00
2 oz	20-415	PVC	Faceted Oval	75.00
2 oz	R4/20	PVC	Faceted Oval	75.00
2 oz	20-415	PVC	Laura Oval	76.00
2 oz	20-410	OPET	Vale Oval	77.10
2 oz	20-415	OPET	Vale Oval	77.10
2 oz	20-410	OPET	Olympian Oval	77.50
2 oz	20-415	OPET	Olympian Oval	77.50
2 oz	20-415	PVC	Ashley Oval	80.00
2 oz	20-410	HDPE	Soft Tapered Oval	81.00
2 oz	20-415	HDPE	Soft Tapered Oval	81.00

Remember, our product line is constantly changing...
Please call us if you do not see what you are looking for !!

INDEX

Size	Neck	Material	Description	Page #
2 oz	20-415	PVC	Beveled Oblong	123.00
2 oz	20-410	OPET	HS Oblong	127.19
2 oz	20-415	OPET	HS Oblong	127.19
2.5 oz	20-410	HDPE / MDPE	Lab Flask	14.40
2.7 oz	24-410 Ramp	HDPE	Pocket Oval	80.80
3 oz	24-410	OPET	Rocky Round	6.90
3 oz	24-415	OPET	Rocky Round	6.90
3 oz	20-410	OPET	Boston Round	7.00
3 oz	20-415	OPET	Boston Round	7.00
4 oz	24-410	PVC	Bullet Top Boston Round	1.00
4 oz	24-415	PVC	Bullet Top Boston Round	1.00
4 oz	24-410	HDPE	Bullet Top Boston Round	3.50
4 oz	20-410	OPET	Bullet Top Boston Round	6.00
4 oz	20-415	OPET	Bullet Top Boston Round	6.00
4 oz	24-410	OPET	Bullet Top Boston Round	6.00
4 oz	24-410	PVC	Boston Round	7.00
4 oz	24-415	PVC	Boston Round	7.00
4 oz	24-400	HDPE	Boston Round	9.00
4 oz	24-410	HDPE	Boston Round	9.00
4 oz	24-415	PVC	Philly Round	12.00
4 oz	24-410	HDPE / LDPE	TK Round	22.00
4 oz	24-410	HDPE	Modern Round	57.00
4 oz	28-410	HDPE	Modern Round	57.00
4 oz	24-400	HDPE	Straight Sided Cylinder	62.00
4 oz	24-410	HDPE	Straight Sided Cylinder	62.00
4 oz	24mm Dab	HDPE	Straight Sided Cylinder	62.00
4 oz	24-415	PVC	Laura Oval	77.00
4 oz	20-410	OPET	Vale Oval	77.10
4 oz	20-415	OPET	Vale Oval	77.10
4 oz	20-410	PVC	Custom Oval	78.00
4 oz	20-415	PVC	Custom Oval	78.00
4 oz	24-415	HDPE	Soft Tapered Oval	81.00

Remember, our product line is constantly changing....
Please call us if you do not see what you are looking for !!

INDEX

Size	Neck	Material	Description	Page #
4 oz	20-410	HDPE	New Flat Oval	108.00
4 oz	22mm PDG	PVC	Beveled Oblong	123.00
4 oz	24-400	HDPE	Graduated Oblong	124.50
4 oz	24-410	OPET	HS Oblong	127.19
4 oz	28-400	HDPE	Center Neck Oblong	137.90
120 ml	24-400	HDPE	Graduated Oblong	124.50
140 ml	43mm Foamer	OPET	Straight Sided Cylinder	63.60
5 oz	24-410	OPET	Tall Slim Cylinder	63.50
5 oz	24-410	OPET	Olympian Oval	77.50
150 ml	24-410	OPET	Tall Slim Cylinder	63.50
6 oz	24-410	OPET	Bullet Top Boston Round	6.25
6 oz	24-415	OPET	Bullet Top Boston Round	6.25
6 oz	24-410	HDPE / LDPE	Philly Round	13.00
6 oz	24-415	HDPE / LDPE	Philly Round	13.00
6 oz	22-400	OPET	Lab Flask	14.50
6 oz	24-410	OPET	Lab Flask	14.50
6 oz	24-410	HDPE	Bella Round	18.00
6 oz	24-415	HDPE	Bella Round	18.00
6 oz	24mm Jazz	HDPE	Bella Round	18.25
6 oz	33mm Drop-Lok	HDPE	Sculpted Round	18.50
6 oz	22-400	PVC	#709 Additive Round	28.00
6 oz	22-414	PVC	#709 Additive Round	28.00
6 oz	22mm Special	OPET	Austin Round Capless Compatible	29.35
6 oz	53-400	OPET	Paneled Round Jar	59.90
6 oz	70-400	HDPE	Wide Mouth Jar	60.00
6 oz	22-400	HDPE	Fleur de lis Tottle	74.25
6 oz	24-410	OPET	Olympian Oval	77.50
6 oz	24-415	OPET	Olympian Oval	77.50
6 oz	22-400	HDPE / MDPE / LDPE	Malibu Tottle	80.50
6 oz	1.5" 22-400	HDPE	Parisian Oval	82.00
6 oz	24-410	HDPE	Parisian Oval	82.00

Remember, our product line is constantly changing....
Please call us if you do not see what you are looking for !!

INDEX

Size	Neck	Material	Description	Page #
6 oz	24-410	HDPE	Beveled Oblong	123.00
6 oz	43-485	PETG	Spicer Oblong	123.50
6 oz	22-400	HDPE	Tall Liberty Oblong	129.00
7 oz	20mm Crimp	PVC	Bullet Top Boston Round	2.00
7 oz	20mm PVCrimp	PVC	Bullet Top Boston Round	2.00
7 oz	22-415	PVC	Bullet Top Boston Round	2.00
7 oz	24-415	PVC	Bullet Top Boston Round	2.00
7 oz	24-410	OPET	Jubilation Round	44.80
220 ml	24-410	OPET	Jubilation Round	44.80
8 oz	24-410	PVC	Bullet Top Boston Round	3.00
8 oz	24-415	PVC	Bullet Top Boston Round	3.00
8 oz	24-410	HDPE	Bullet Top Boston Round	3.50
8 oz	24-410	OPET	Bullet Top Boston Round	6.25
8 oz	24-415	OPET	Bullet Top Boston Round	6.25
8 oz	24-410	PVC	Boston Round	8.00
8 oz	24-415	PVC	Boston Round	8.00
8 oz	24-410	HDPE	Boston Round	9.00
8 oz	24-410	PVC	Footed Boston Round	10.00
8 oz	24-415	PVC	Footed Boston Round	10.00
8 oz	24-410	PVC / OPET	Philly Round	13.00
8 oz	24-415	PVC / OPET	Philly Round	13.00
8 oz	24-400 Special	PVC	Philly Round	13.00
8 oz	28-400	PVC	Philly Round	13.00
8 oz	28-400	HDPE	Celebrity Round	19.00
8 oz	28-410	HDPE	Celebrity Round	19.00
8 oz	20-410	HDPE	TK Round	22.00
8 oz	22-415	HDPE	TK Round	22.00
8 oz	24-410	HDPE	TK Round	22.00
8 oz	22-400	OPET	Austin Round	29.30
8 oz	22mm Special	OPET	Austin Round Capless Compatible	29.35
8 oz	33-400	PVC / PETG	Austin Round	29.50
8 oz	22-400	PVC / PETG	Austin Round	30.00
8 oz	22-400	HDPE	Austin Round	30.10

Remember, our product line is constantly changing....
Please call us if you do not see what you are looking for !!

INDEX

Size	Neck	Material	Description	Page #
8 oz	22-400	HDPE	Austin Round/Long Neck	30.12
8 oz	22mm SPCC	HDPE	Austin Round/Long Neck	30.12
8 oz	28-400	HDPE	Cone Top Round	32.00
8 oz	28-400	HDPE	Modern Round	57.00
8 oz	28-410	HDPE	Modern Round	57.00
8 oz	28mm Jigger	PVC / PETG	Harbour Round	59.50
8 oz	24-410	HDPE	Straight Sided Cylinder	63.00
8 oz	24-415	HDPE	Straight Sided Cylinder	63.00
8 oz	38-400	HDPE	Straight Sided Cylinder	63.00
8 oz	24-410	PVC	Straight Sided Cylinder	63.00
8 oz	24-410	OPET	Straight Sided Cylinder	64.00
8 oz	24-415	OPET	Straight Sided Cylinder	64.00
8 oz	22-400	PVC	#639 Additive Oval	72.00
8 oz	22-415	PVC	#639 Additive Oval	72.00
8 oz	24-410	PVC	Fleur de lis Oval	74.50
8 oz	24-415	PVC	Fleur de lis Oval	74.50
8 oz	24-415	PVC	Footed Fleur de lis Oval	74.75
8 oz	24-410	PVC	Faceted Oval	75.00
8 oz	24-415	PVC	Faceted Oval	75.00
8 oz	R4/24	PVC	Faceted Oval	75.00
8 oz	24-410	PVC	Laura Oval	77.00
8 oz	24-415	PVC	Laura Oval	77.00
8 oz	24-410	OPET	Vale Oval	77.10
8 oz	24-415	OPET	Vale Oval	77.10
8 oz	24-410	OPET	Olympian Oval	77.50
8 oz	24-415	OPET	Olympian Oval	77.50
8 oz	24-415	PVC	Ashley Oval	80.00
8 oz	24-415	HDPE	Soft Tapered Oval	81.00
8 oz	24mm	HDPE	Soft Tapered Oval	81.00
8 oz	24-410	HDPE	Ocular Oval	82.50
8 oz	24-410	PVC	New Vienna Oval	83.00
8 oz	24-415	PVC	New Vienna Oval	83.00
8 oz	20-410	HDPE	Symphony Oval	84.00
8 oz	28-400 Ramp	HDPE	Rounded Pistol Grip Sprayer Oval	87.80
8 oz	28-410 Ramp	HDPE	Rounded Pistol Grip Sprayer Oval	87.80
8 oz	28mm WestRock Ratchet	HDPE	Rounded Pistol Grip Sprayer Oval	87.80

Remember, our product line is constantly changing....
Please call us if you do not see what you are looking for !!

INDEX

Size	Neck	Material	Description	Page #
8 oz	24-415	PVC	Beveled Oblong	123.00
8 oz	30mm Foamer	HDPE	Eclipse Oblong	123.10
8 oz	33-400	HDPE	Ideal Oblong	124.70
8 oz	33mm PTI Sifter	HDPE	Ideal Oblong	124.75
8 oz	24-410	OPET	HS Oblong	127.20
8 oz	24-410	HDPE	Elite Oblong	127.50
8 oz	24-415	HDPE	Elite Oblong	127.50
8 oz	22-400	HDPE	Tall Liberty Oblong	129.00
8 oz	22-400	PVC	Liberty Oblong	129.50
8 oz	28-400	HDPE	Offset Neck Oblong	138.00
8 oz	28mm Drop-Lok	HDPE	Offset Neck Oblong	138.00
8 oz	28-400	HDPE	Concave / Convex Flask	147.00
8 oz	28-400	PVC / HDPE	F Style Jug	152.00
8 oz	28-400	HDPE	F Style Jug	153.00
8 oz	33-400	HDPE	F Style Jug	153.00
250 ml	28-410	OPET	Footed Bullet Top Boston Round	6.75
250 ml	22-400	OPET	Austin Round	29.30
250 ml	28-400	HDPE	Cone Top Round	32.00
250 ml	24-410	OPET	Straight Sided Cylinder	64.00
250 ml	24-415	OPET	Straight Sided Cylinder	64.00
250 ml	28-400 Ramp	HDPE	Rounded Pistol Grip Sprayer Oval	87.80
250 ml	28-410 Ramp	HDPE	Rounded Pistol Grip Sprayer Oval	87.80
250 ml	28mm WestRock Ratchet	HDPE	Rounded Pistol Grip Sprayer Oval	87.80
250 ml	30mm Foamer	HDPE	Eclipse Oblong	123.10
250 ml	33-400	HDPE	Ideal Oblong	124.70
250 ml	33mm PTI Sifter	HDPE	Ideal Oblong	124.75
250 ml	24-410	HDPE	Elite Oblong	127.50
250 ml	24-415	HDPE	Elite Oblong	127.50
250 ml	28-400	HDPE	Offset Neck Oblong	138.00
250 ml	28mm Drop-Lok	HDPE	Offset Neck Oblong	138.00
250 ml	28-400	PVC / HDPE	F Style Jug	152.00
250 ml	28-400	HDPE	F Style Jug	153.00
250 ml	33-400	HDPE	F Style Jug	153.00
10 oz	24-410	HDPE	Paneled Cylinder	68.50

Remember, our product line is constantly changing....
Please call us if you do not see what you are looking for !!

INDEX

Size	Neck	Material	Description	Page #
10 oz	24-410	OPET	Optimum Oval	77.75
10 oz	24-415	OPET	Optimum Oval	77.75
10 oz	28-415	PVC	Rectangular	151.00
350 ml	28-400	HDPE	Cone Top Round	32.00
350 ml	28-400	HDPE	Cone Top Round II	32.50
350 ml	28mm Ratchet	OPET	Pistol Gripper Sprayer Oval	86.25
350 ml	24-410	HDPE	EZ Grip Oblong	124.00
350 ml	24-415	HDPE	EZ Grip Oblong	124.00
350 ml	28-400	HDPE	EZ Grip Oblong	124.00
12 oz	24-410	OPET	Bullet Top Boston Round	6.25
12 oz	24-415	OPET	Bullet Top Boston Round	6.25
12 oz	28-410	HDPE	Boston Round	9.00
12 oz	28-410	OPET	Cheshire Round	10.10
12 oz	28mm Ratchet	OPET	Cheshire Round	10.10
12 oz	28-400	PVC	Philly Round	13.00
12 oz	22-400	OPET	Lab Flask	14.50
12 oz	28-410	OPET	Lab Flask	14.50
12 oz	24-415	PVC	Bell Round	15.00
12 oz	24-410	HDPE	TK Round	22.00
12 oz	24-400	PVC	#709 Additive Round	28.00
12 oz	20-400	HDPE	#709 Additive Round	29.00
12 oz	21mm Snap	HDPE	#709 Additive Round	29.00
12 oz	24-400	HDPE	#709 Additive Round	29.00
12 oz	22mm Special	PVC / OPET	Austin Round Capless Compatible	29.35
12 oz	21mm Snap	PVC	Austin Round	30.00
12 oz	22-400	PVC	Austin Round	30.00
12 oz	20mm SPCC	HDPE	Austin Round	30.10
12 oz	22mm SPCC	HDPE	Austin Round	30.10
12 oz	22-400	HDPE	Austin Round	30.10
12 oz	24-410	OPET	Roman Round	30.25
12 oz	24-415	OPET	Roman Round	30.25
12 oz	28-400	HDPE	Cone Top Round	32.00
12 oz	28-400	HDPE	Cone Top Round II	32.50
12 oz	24-400	HDPE	Plastic Can	34.00

Remember, our product line is constantly changing....
Please call us if you do not see what you are looking for !!

INDEX

Size	Neck	Material	Description	Page #
12 oz	24-410	PVC	Straight Sided Cylinder	64.00
12 oz	24-410	HDPE	Paneled Cylinder	69.00
12 oz	28-410	HDPE	Paneled Cylinder	69.00
12 oz	22-400	PVC	#639 Additive Oval	73.00
12 oz	24-410	OPET	Vale Oval	77.10
12 oz	24-415	OPET	Vale Oval	77.10
12 oz	24-410	OPET	Straight Sided Oval	77.25
12 oz	24-415	OPET	Straight Sided Oval	77.25
12 oz	24-410	HDPE	Pinched Oval	82.80
12 oz	28mm Ratchet	OPET	Pistol Gripper Sprayer Oval	86.25
12 oz	28-400 Ramp	HDPE	Euro Twist Grip® Sprayer Oval	94.50
12 oz	28mm Ratchet	HDPE	Euro Twist Grip® Sprayer Oval	94.50
12 oz	28-410 Low H	OPET	Euro Twist Grip® Sprayer Oval	94.60
12 oz	28mm Ratchet	OPET	Euro Twist Grip® Sprayer Oval	94.60
12 oz	24-415	HDPE	Wide High Brow Oval	109.00
12 oz	22-400	PVC	Liberty Oblong	130.00
12 oz	22-400	Mono or Tri-Layer HDPE	Liberty Oblong	130.00
12 oz	24-410	PVC	Liberty Oblong	130.00
12 oz	33-400	PVC	Liberty Oblong	130.00
12 oz	22-400	PVC	Footed Liberty Oblong	135.00
12 oz	22-400	Mono or Tri-Layer HDPE	Footed Liberty Oblong	135.00
12 oz	28mm Drop-Lok	Mono or Tri-Layer HDPE	Footed Liberty Oblong	135.00
12 oz	22-400	PVC	Steady Grip® Offset Neck Oblong	136.00
12 oz	33-400	PVC	Steady Grip® Offset Neck Oblong	137.00
13 oz	28-410	PVC / PETG	Memphis Oblong	127.00
13 oz	22-400	HDPE / PP	Liberty Oblong	131.00
13 oz	28-400	PVC / HDPE / PP	Liberty Oblong	131.00
13 oz	33-400	HDPE / PP	Liberty Oblong	131.00
13.5 oz	28-410	HDPE	Reverse Tapered Oval	81.25
13.5 oz	26mm Snap-On	PVC	Cosmopolitan Oblong	125.00
400 ml	24-410	OPET	Venus Round	10.25
400 ml	24-415	OPET	Venus Round	10.25
400 ml	24-410	OPET	5 th Avenue Oval	84.25

Remember, our product line is constantly changing....
Please call us if you do not see what you are looking for !!

INDEX

Size	Neck	Material	Description	Page #
400 ml	24-415	OPET	5 th Avenue Oval	84.25
14 oz	63-485	HDPE	Paneled Cylinder	65.50
14 oz	28-410	OPET	Serenity Oval	84.75
14 oz	28-415	OPET	Serenity Oval	84.75
14 oz	33-400	PVC	Liberty Oblong	132.00
440 ml	24-410	HDPE	EZ Grip Oblong	124.00
440 ml	24-415	HDPE	EZ Grip Oblong	124.00
440 ml	28-400	HDPE	EZ Grip Oblong	124.00
15 oz	24-410	OPET	Capitol Round	10.50
15 oz	24-415	OPET	Capitol Round	10.50
15 oz	24-415	HDPE	Straight Sided Cylinder	64.00
15 oz	33-400	PVC	Ringed Cylinder	70.00
15 oz	24-410	OPET	Venetian Oval	84.50
15 oz	24-415	OPET	Venetian Oval	84.50
15 oz	28-410	OPET	Memphis Oblong	127.00
15 oz	28-415	OPET	Memphis Oblong	127.00
15 oz	22-400	PVC	Liberty Oblong	132.00
15 oz	24-400	PVC	Liberty Oblong	132.00
15 oz	33-400	PVC	Liberty Oblong	132.00
16 oz	24-410	HDPE	Bullet Top Boston Round	3.50
16 oz	24-415	HDPE	Bullet Top Boston Round	3.50
16 oz	28-410	HDPE	Bullet Top Boston Round	3.50
16 oz	24-410	OPET	Bullet Top Boston Round	6.30
16 oz	28-410	OPET / PVC	Bullet Top Boston Round	6.30
16 oz	28-415	OPET	Bullet Top Boston Round	6.30
16 oz	28-410	OPET	Footed Bullet Top Boston Round	6.75
16 oz	28-415	OPET	Footed Bullet Top Boston Round	6.75
16 oz	24-415	HDPE	TK Round	22.00
16 oz	22-400	OPET	Austin Round	29.40
16 oz	33-400	PVC	Austin Round	29.60
16 oz	20-400	PVC	Austin Round	30.00
16 oz	21mm Snap	PVC	Austin Round	30.00

Remember, our product line is constantly changing....
Please call us if you do not see what you are looking for !!

INDEX

Size	Neck	Material	Description	Page #
16 oz	22-400	PVC	Austin Round	30.00
16 oz	20mm SPCC	HDPE	Austin Round	30.11
16 oz	22mm SPCC	HDPE	Austin Round	30.11
16 oz	22-400	HDPE	Austin Round	30.11
16 oz	28-400	HDPE	Cone Top Round	32.00
16 oz	28-400	OPET	Cone Top Round	33.00
16 oz	38-400	OPET	Fluted Round	35.60
16 oz	28-400	PVC	Ringed Carafe	36.00
16 oz	28-400	HDPE	Ringed Carafe	36.00
16 oz	28-410	HDPE	Ringed Carafe	36.00
16 oz	38mm LT	HDPE	Ringed Carafe	36.00
16 oz	28-400	PVC	Giraffe Carafe	44.00
16 oz	28-400	HDPE	Fluted Decanter	48.00
16 oz	28-410	HDPE	Fluted Decanter	48.00
16 oz	38mm LT	HDPE	Fluted Decanter	48.00
16 oz	28-410	HDPE	Modern Round	57.20
16 oz	28mm TE	HDPE	Modern Round	57.20
16 oz	28-410	HDPE	The Classic Modern Round	58.00
16 oz	28mm Jigger	PVC / PETG	Harbour Round	59.50
16 oz	63-485	HDPE	Modified Round	60.40
16 oz	24-410	HDPE	Straight Sided Cylinder	64.00
16 oz	28-410	HDPE / OPET	Straight Sided Cylinder	64.00
16 oz	28-415	OPET	Straight Sided Cylinder	64.00
16 oz	63-485	HDPE	Straight Sided Cylinder	66.00
16 oz	28-400	HDPE / LDPE	Paneled Cylinder	69.00
16 oz	28-410	HDPE / LDPE	Paneled Cylinder	69.00
16 oz	28-410	OPET	Ribbed Oval	77.20
16 oz	28-415	OPET	Ribbed Oval	77.20
16 oz	28-410	OPET	Straight Sided Oval	77.25
16 oz	28-415	OPET	Straight Sided Oval	77.25
16 oz	28-410	OPET	Santa Fe Oval	77.30
16 oz	28-415	OPET	Santa Fe Oval	77.30
16 oz	28-400	OPET	Pistol Gripper Sprayer Oval	86.50
16 oz	28mm Ratchet	OPET	Pistol Gripper Sprayer Oval	86.50
16 oz	28-400 Ramp	HDPE	Twist Grip® 2000 Sprayer Oval	94.00
16 oz	28mm WestRock Ratchet	HDPE	Twist Grip® 2000 Sprayer Oval	94.00

Remember, our product line is constantly changing...
Please call us if you do not see what you are looking for !!

INDEX

Size	Neck	Material	Description	Page #
16 oz	28mm Guala Ratchet	HDPE	Twist Grip® 2000 Sprayer Oval	94.00
16 oz	28-400 Ramp	HDPE	Euro Twist Grip® Sprayer Oval	94.50
16 oz	28mm 6Ratchet	HDPE	Euro Twist Grip® Sprayer Oval	94.50
16 oz	28mm 8Ratchet	HDPE	Euro Twist Grip® Sprayer Oval	94.50
16 oz	28mm Special	OPET	Euro Twist Grip® Sprayer Oval	94.60
16 oz	28mm Ratchet	OPET	Euro Twist Grip® Sprayer Oval	94.60
16 oz	28-400 Ramp	HDPE	Gripped Sprayer Oval	94.70
16 oz	28-400	OPET	Millennium Twist Grip® Sprayer Oval	96.00
16 oz	28-400	OPET	PBC Twist Grip® Sprayer Oval	96.50
16 oz	28mm Ratchet	OPET	PBC Twist Grip® Sprayer Oval	96.50
16 oz	28-400 .450" H	PVC	Viper Sprayer Oval	97.50
16 oz	28mm anti-backoff	PVC	Viper Sprayer Oval	97.50
16 oz	28-400 Ramp	PVC	Sprayer Oval	98.00
16 oz	28mm Anti Back Off	PVC	Sprayer Oval	98.00
16 oz	28-400 Ramp	HDPE	Sprayer Oval	100.00
16 oz	28mm Antirotation	HDPE	Sprayer Oval	100.00
16 oz	28mm Ratchet	HDPE	Sprayer Oval	100.00
16 oz	28-400	PVC	Wide High Brow Oval	110.00
16 oz	28-410	PVC	Wide High Brow Oval	110.00
16 oz	28-415	PVC	Wide High Brow Oval	110.00
16 oz	28mm Jigger	PVC	Wide High Brow Oval	110.25
16 oz	28-400	PVC	Tall High Brow Oval	111.00
16 oz	28-410	PVC	Tall High Brow Oval	111.00
16 oz	28-415	PVC	Tall High Brow Oval	111.00
16 oz	28-410	PP / HDPE	Royal Oval	116.00
16 oz	28-400	HDPE	Graduated Oblong	124.50
16 oz	28-400	OPET	Sierra Oblong	128.00
16 oz	22-400	PVC	Liberty Oblong	132.10
16 oz	28-400	PVC	Liberty Oblong	132.10
16 oz	28-400	HDPE	Offset Neck Oblong	138.00
16 oz	28-410	HDPE	Offset Neck Oblong	138.00
16 oz	28mm Drop-Lok	HDPE	Offset Neck Oblong	138.00
16 oz	28mm Uni-Lok	HDPE	Offset Neck Oblong	139.00
16 oz	33-400	HDPE	Offset Neck Oblong	139.00
16 oz	28-410	HDPE	Dover Oblong	139.10
16 oz	30mm Foamer	HDPE	Dover Oblong	139.10

Remember, our product line is constantly changing...
Please call us if you do not see what you are looking for !!

INDEX

Size	Neck	Material	Description	Page #
16 oz	33-400	HDPE	Daytona Oblong	142.00
16 oz	33-400	HDPE	Galaxy Oblong	148.25
16 oz	28mm Drop-Lok	HDPE	Pharma Oblong	148.50
16 oz	28-400	HDPE	Pinch Waist Oblong	149.00
16 oz	38-400	OPET	Simple Square	149.80
16 oz	28-400	HDPE	F Style Jug	153.00
16 oz	33-400	HDPE	F Style Jug	153.00
500 ml	28-410	OPET	Footed Bullet Top Boston Round	6.75
500 ml	28-415	OPET	Footed Bullet Top Boston Round	6.75
500 ml	22-400	OPET	Austin Round	29.40
500 ml	33-400	PVC	Austin Round	29.60
500 ml	28-400	HDPE	Cone Top Round	32.00
500 ml	28-400	OPET	Cone Top Round	33.00
500 ml	28-400	PVC	Highland Round	35.00
500 ml	28-400	PVC	Ringed Carafe	36.00
500 ml	63-485	HDPE	Modified Round	60.40
500 ml	24-410sp	HDPE	Straight Sided Cylinder	64.00
500 ml	28-410sp	HDPE	Straight Sided Cylinder	64.00
500 ml	28-410	OPET	Straight Sided Cylinder	64.00
500 ml	28-415	OPET	Straight Sided Cylinder	64.00
500 ml	28-410	OPET	Santa Fe Oval	77.30
500 ml	28-415	OPET	Santa Fe Oval	77.30
500 ml	28-400	OPET	Pistol Gripper Sprayer Oval	86.50
500 ml	28mm Ratchet	OPET	Pistol Gripper Sprayer Oval	86.50
500 ml	28-400 Ramp	HDPE	Twist Grip® Sprayer Oval	93.00
500 ml	28mm Ratchet	HDPE	Twist Grip® Sprayer Oval	93.00
500 ml	28-400 Ramp	HDPE	Twist Grip® 2000 Sprayer Oval	94.00
500 ml	28mm WestRock Ratchet	HDPE	Twist Grip® 2000 Sprayer Oval	94.00
500 ml	28mm Guala Ratchet	HDPE	Twist Grip® 2000 Sprayer Oval	94.00
500 ml	28-400 Ramp	HDPE	Euro Twist Grip® Sprayer Oval	94.50
500 ml	28mm 6Ratchet	HDPE	Euro Twist Grip® Sprayer Oval	94.50
500 ml	28mm 8Ratchet	HDPE	Euro Twist Grip® Sprayer Oval	94.50
500 ml	28-400 Ramp	HDPE	Gripped Sprayer Oval	94.70
500 ml	28-400	OPET	Millennium Twist Grip® Sprayer Oval	96.00
500 ml	28-400 Ramp	PVC	Sprayer Oval	99.00

Remember, our product line is constantly changing....

Please call us if you do not see what you are looking for !!

INDEX

Size	Neck	Material	Description	Page #
500 ml	28mm Anti Back Off	PVC	Sprayer Oval	99.00
500 ml	28-400 Ramp	HDPE	Sprayer Oval	100.00
500 ml	28mm Antirotation	HDPE	Sprayer Oval	100.00
500 ml	28mm Ratchet	HDPE	Sprayer Oval	100.00
500 ml	28-400	PVC	Wide High Brow Oval	110.00
500 ml	28-410	PVC	Wide High Brow Oval	110.00
500 ml	28-415	PVC	Wide High Brow Oval	110.00
500 ml	28-400	HDPE	Graduated Oblong	124.50
500 ml	28-400	OPET	Sierra Oblong	128.00
500 ml	28-400	HDPE	Offset Neck Oblong	138.00
500 ml	28-410	HDPE	Offset Neck Oblong	138.00
500 ml	28mm Drop-Lok	HDPE	Offset Neck Oblong	138.00
500 ml	28mm Uni-Lok	HDPE	Offset Neck Oblong	139.00
500 ml	33-400	HDPE	Offset Neck Oblong	139.00
500 ml	33-400	HDPE	Daytona Oblong	142.00
500 ml	58-400	HDPE	Nautical Square	149.70
500 ml	58mm Pano T/E	HDPE	Nautical Square	149.70
500 ml	28-400	HDPE	F Style Jug	153.00
500 ml	33-400	HDPE	F Style Jug	153.00
17 oz	28-400 Ramp	HDPE	Twist Grip® Sprayer Oval	93.00
17 oz	28mm Ratchet	HDPE	Twist Grip® Sprayer Oval	93.00
17 oz	28-400 Ramp	PVC	Sprayer Oval	99.00
17 oz	28mm Anti Back Off	PVC	Sprayer Oval	99.00
17 oz	22-400	PVC	Liberty Oblong	134.00
17 oz	28-400	PVC	Liberty Oblong	134.00
17 oz	58-400	HDPE	Nautical Square	149.70
17 oz	58mm Pano T/E	HDPE	Nautical Square	149.70
525 ml	28-410	HDPE	Modern Round	57.20
530 ml	24-410	HDPE	EZ Grip Oblong	124.10
530 ml	24-415	HDPE	EZ Grip Oblong	124.10
530 ml	28-400	HDPE	EZ Grip Oblong	124.10
18 oz	28-410	OPET	Footed Bullet Top Boston Round	6.75

Remember, our product line is constantly changing...
Please call us if you do not see what you are looking for !!

INDEX

Size	Neck	Material	Description	Page #
18 oz	28-415	OPET	Footed Bullet Top Boston Round	6.75
18 oz	24-410	HDPE	Straight Sided Cylinder	65.00
18 oz	38-400	HDPE	Straight Sided Cylinder	65.00
18 oz	22-400	PVC	Steady Grip® Offset Neck Oblong	136.00
19 oz	24-410	HDPE	Boston Round	9.0
19 oz	33-400	HDPE	Tall Oval	113.00
19 oz	33mm Magenta	HDPE	Tall Oval	113.00
20 oz	28-400 Ramp	PVC	Original Pistol Grip Sprayer Oval	89.00
20 oz	24-410	HDPE	Flask	115.00
20 oz	28-400	HDPE	Offset Neck Oblong	139.00
22 oz	28-410	OPET	Cone Top Round	32.60
22 oz	28mm Snap-On	HDPE	Empress Oval	82.90
22 oz	28-400 .465H	OPET	Pistol Gripper Sprayer Oval	87.00
22 oz	28mm Ratchet	OPET	Pistol Gripper Sprayer Oval	87.00
22 oz	28-400 Ramp	HDPE	Original Pistol Grip Sprayer Oval	89.00
22 oz	28-400	HDPE	Vernon Sprayer Oval	97.00
22 oz	28mm Anti-rotation	HDPE	Vernon Sprayer Oval	97.00
22 oz	28mm Ratchet	HDPE	Vernon Sprayer Oval	97.00
22 oz	28-400 .440" H	HDPE	Panther Sprayer Oval	101.50
22 oz	28mm anti-backoff	HDPE	Panther Sprayer Oval	101.50
22 oz	28-400	HDPE	Rondout Oval	104.00
22 oz	28-410	HDPE	Rondout Oval	104.00
22 oz	33-430	PVC	Handleware Oval	118.00
22 oz	38-400	PVC	Handleware Oval	118.00
22 oz	38-430	PVC	Handleware Oval	118.00
22 oz	40mm	PVC	Handleware Oval	118.00
22 oz	28-415	OPET	Custom Oblong	127.40
700 ml	63-485	HDPE	Straight Sided Cylinder	66.00
700 ml	24-410	HDPE	EZ Grip Oblong	124.10
700 ml	24-415	HDPE	EZ Grip Oblong	124.10
700 ml	28-400	HDPE	EZ Grip Oblong	124.10

Remember, our product line is constantly changing....
Please call us if you do not see what you are looking for !!

INDEX

Size	Neck	Material	Description	Page #
24 oz	28-400 Ramp	HDPE	Graduated Service Round	41.00
24 oz	38-400	OPET	Sassy Round	43.50
24 oz	63-485	HDPE	Straight Sided Cylinder	66.00
24 oz	28-400 Ramp	HDPE	Rounded Pistol Grip Sprayer Oval	88.30
24 oz	28mm WestRock Ratchet	HDPE	Rounded Pistol Grip Sprayer Oval	88.30
24 oz	28mm K2K Hose End Sprayer	HDPE	Rounded Pistol Grip Sprayer Oval	88.30
24 oz	28mm Special HP2/HP3 Hose End	HDPE	Rounded Pistol Grip Sprayer Oval	88.40
24 oz	28-400	HDPE	Sunny Twist Grip® Sprayer Oval	92.80
24 oz	28-400 Ramp	HDPE	Twist Grip® Sprayer Oval	93.00
24 oz	28-400	OPET	Twist Grip® Sprayer Oval	93.00
24 oz	28mm 4Rat WTB	OPET	Twist Grip® Sprayer Oval	93.00
24 oz	28mm 8Rat WSR	OPET	Twist Grip® Sprayer Oval	93.00
24 oz	28mm WestRock Ratchet	HDPE	Metro Sprayer Oval	93.50
24 oz	28-400 Ramp	HDPE	Twist Grip® 2000 Sprayer Oval	94.00
24 oz	28-400 Ramp	HDPE	Euro Twist Grip® Sprayer Oval	94.50
24 oz	28-400	OPET	Euro Twist Grip® Sprayer Oval	94.60
24 oz	28mm Ratchet	OPET	Euro Twist Grip® Sprayer Oval	94.60
24 oz	28-400 Ramp	HDPE	Sprayer Oval	100.00
24 oz	28mm Ratchet	HDPE	Sprayer Oval	100.00
24 oz	28mm 6Ratchet Mixer	HDPE	Sprayer Oval	100.00
24 oz	28-410	HDPE	Original Ludington Oval	114.00
24 oz	28mm PS211	HDPE	Original Ludington Oval	114.00
24 oz	33-400	HDPE	Original Ludington Oval	114.00
24 oz	33-480	HDPE	New Ludington Oval	114.15
24 oz	38-400	HDPE	Daytona Oblong	142.00
24 oz	28mm	HDPE	Tilt-Neck Oblong	145.00
24 oz	33-400	HDPE	F Style Jug	153.00
24 oz	33-400	HDPE	Slant Handle F Style Jug	155.00
750 ml	28-400	HDPE	Sunny Twist Grip® Sprayer Oval	92.80
750 ml	28-400 Ramp	HDPE	Twist Grip® 2000 Sprayer Oval	94.00
750 ml	38-400	HDPE	Daytona Oblong	142.00

Remember, our product line is constantly changing...
Please call us if you do not see what you are looking for !!

INDEX

Size	Neck	Material	Description	Page #
26 oz	28-400	OPET	Pistol Gripper Sprayer Oval	87.20
26 oz	28-400 Ramp	PVC	Millennium Twist Grip® Sprayer Oval	95.00
26 oz	28-400 .475"	OPET	Millennium Twist Grip® Sprayer Oval	96.00
26 oz	28mm Ratchet	OPET	Millennium Twist Grip® Sprayer Oval	96.00
27 oz	28-400 Ramp	PVC	Original Pistol Grip Sprayer Oval	90.00
27 oz	28mm Antirotation	PVC	Original Pistol Grip Sprayer Oval	90.00
27 oz	28-400 Ramp	HDPE	Twist Grip® 2000 Sprayer Oval	94.00
27 oz	28-400 Ramp	HDPE	Euro Twist Grip® Sprayer Oval	94.51
27 oz	28-410	HDPE	Original Ludington Oval	114.00
27 oz	28mm PS211	HDPE	Original Ludington Oval	114.00
27 oz	33-400	HDPE	Original Ludington Oval	114.00
800 ml	28-400 Ramp	PVC	Original Pistol Grip Sprayer Oval	90.00
800 ml	28mm Antirotation	PVC	Original Pistol Grip Sprayer Oval	90.00
800 ml	28-400 Ramp	HDPE	Twist Grip® 2000 Sprayer Oval	94.00
800 ml	28-400 Ramp	HDPE	Euro Twist Grip® Sprayer Oval	94.51
28 oz	28-400	HDPE	Ultra Oval	106.00
28 oz	28P100	HDPE	Ultra Oval	106.00
28 oz	33-400	HDPE	Barrington Oblong	146.00
30 oz	89-400	HDPE	Pinch Grip Square	149.60
32 oz	28-400	OPET	Bullet Top Boston Round	6.50
32 oz	28-410	OPET	Bullet Top Boston Round	6.50
32 oz	28-410	OPET	Cosmo Round	6.60
32 oz	38-430	HDPE	Smooth Buttress Boston Round	20.00
32 oz	38-430	HDPE	Boston Round Buttress	20.50
32 oz	28-410	HDPE	TK Round	23.00
32 oz	28-400	OPET	Roman Round	30.25
32 oz	28mm Kerr Tamper Evident	OPET	Roman Round	30.25
32 oz	28-400	HDPE	Cone Top Round II	32.50
32 oz	38-400	OPET	Fluted Round	35.60
32 oz	28-400	PVC	Ringed Carafe	37.00

Remember, our product line is constantly changing...
Please call us if you do not see what you are looking for !!

INDEX

Size	Neck	Material	Description	Page #
32 oz	28-410	PVC	Ringed Carafe	37.00
32 oz	28-400	OPET	Ringed Carafe	38.00
32 oz	28-410	OPET	Ringed Carafe	38.00
32 oz	28mm Ratchet	OPET	Ringed Carafe	39.00
32 oz	28-400 Ramp	PVC	Ringed Ribbed Carafe	40.00
32 oz	28-400 Ramp	HDPE	#503242 Fluted Carafe	42.00
32 oz	28-410	HDPE	#503242 Fluted Carafe	42.00
32 oz	28mm PS211	HDPE	#503242 Fluted Carafe	42.00
32 oz	28-400 Ramp	HDPE	#503242 Ringed Carafe	43.00
32 oz	28-410	HDPE	#503242 Ringed Carafe	43.00
32 oz	28mm PS211	HDPE	#503242 Ringed Carafe	43.00
32 oz	28-400T	OPET	Hybrid Round	44.50
32 oz	28mm Ratchet	OPET	Hybrid Round	44.50
32 oz	28-400	OPET	MXR Round	44.75
32 oz	28mm KERR Tamper Evident	OPET	MXR Round	44.75
32 oz	28-400	OPET	Jubilation Round	44.80
32 oz	28mm KERR Tamper Evident	OPET	Jubilation Round	44.80
32 oz	38-400	OPET	Jubilation II Round	44.85
32 oz	28-400	HDPE	#101 Ringed Top Round	45.00
32 oz	33-400	HDPE	#101 Ringed Top Round	45.00
32 oz	28-400 Ramp	HDPE	#102 Ringed Carafe	46.00
32 oz	28-410	HDPE	#102 Ringed Carafe	46.00
32 oz	28-400 Ramp	HDPE	#102 Fluted Carafe	47.00
32 oz	28-410	HDPE	#102 Fluted Carafe	47.00
32 oz	28mm PS211	HDPE	Fluted Decanter	48.00
32 oz	38-400	HDPE	Fluted Decanter	48.00
32 oz	28-400 sp	HDPE	#710 Bulb Top Round	49.00
32 oz	28-410	HDPE	#710 Bulb Top Round	49.00
32 oz	28-400	HDPE	Big Gripper	50.00
32 oz	28mm PS211	HDPE	Big Gripper	50.00
32 oz	28-410	HDPE	Modern Round	59.00
32 oz	28mm HP2/HP3 Hose End	HDPE	Modern Round	59.00
32 oz	38-400	HDPE	Modern Round	59.00
32 oz	53-400	HDPE	Packer Round	60.10

Remember, our product line is constantly changing...
Please call us if you do not see what you are looking for !!

INDEX

Size	Neck	Material	Description	Page #
32 oz	28-410	HDPE	Straight Sided Cylinder	67.00
32 oz	38-400	HDPE	Straight Sided Cylinder	67.00
32 oz	48-400	HDPE	Straight Sided Cylinder	67.00
32 oz	28-400	OPET	Tall Slim Cylinder	68.00
32 oz	28-400	HDPE	#639 Additive Oval	74.00
32 oz	28-400	OPET	Pistol Gripper Sprayer Oval	87.20
32 oz	28-400	OPET	Ringed Grip Sprayer Oval	87.50
32 oz	28mm Ratchet	OPET	Ringed Grip Sprayer Oval	87.50
32 oz	28-400	OPET	Rounded Pistol Grip Sprayer Oval	88.00
32 oz	28mm Ratchet	OPET	Rounded Pistol Grip Sprayer Oval	88.00
32 oz	28-400 Ramp	HDPE	Twist Grip® 2000 Sprayer Oval	94.10
32 oz	28-400 Ramp	HDPE	Euro Twist Grip® Sprayer Oval	94.51
32 oz	28mm 6Ratchet	HDPE	Euro Twist Grip® Sprayer Oval	94.51
32 oz	28mm 8Ratchet	HDPE	Euro Twist Grip® Sprayer Oval	94.51
32 oz	28mm HP2/HP3 Hose End	HDPE	Euro Twist Grip® Sprayer Oval	94.51
32 oz	28-400 Ramp	HDPE	Premier Pistol Grip Sprayer Oval	94.75
32 oz	28mm 6Ratchet	HDPE	Premier Pistol Grip Sprayer Oval	94.75
32 oz	28mm 8Ratchet	HDPE	Premier Pistol Grip Sprayer Oval	94.75
32 oz	28mm HP2/HP3 Hose End	HDPE	Premier Pistol Grip Sprayer Oval	94.75
32 oz	28-400	OPET	Millennium Twist Grip® Sprayer Oval	96.00
32 oz	28mm Ratchet	OPET	Millennium Twist Grip® Sprayer Oval	96.00
32 oz	28-400 Ramp	HDPE	Sprayer Oval	101.00
32 oz	28-400	HDPE	Rondout Oval	105.00
32 oz	28P100	HDPE	Rondout Oval	105.00
32 oz	28-415	HDPE	Rondout Oval	105.00
32 oz	28mm Stull P/P	HDPE	Tall High Brow Oval	112.00
32 oz	28-410	HDPE	Tall High Brow Oval	112.00
32 oz	33-430	PVC	Royal Oval	116.00
32 oz	33-430	HDPE / PP	Royal Handleware Oval	117.00
32 oz	33-400 Anti-Glug	HDPE	Klean-Pour® Handleware Oval	119.00
32 oz	28-410	HDPE	Award Handleware Oval	121.00
32 oz	33-400	HDPE	Wave Gripped Oval	122.50
32 oz	28-400	OPET	Sierra Oblong	128.00
32 oz	28-400	HDPE	Center Neck Oblong w/Graduations	137.95
32 oz	28-400	HDPE	Offset Neck Oblong	139.00

Remember, our product line is constantly changing....

Please call us if you do not see what you are looking for !!

INDEX

Size	Neck	Material	Description	Page #
32 oz	28-400	PVC	Offset Neck Oblong	140.00
32 oz	33-400	PVC	Offset Neck Oblong	140.00
32 oz	28-400	PVC	Octane Oblong	140.50
32 oz	28-400	PVC	Center Neck Oblong	141.00
32 oz	33-400	PVC	Center Neck Oblong	141.00
32 oz	38-400	HDPE	Daytona Oblong	142.00
32 oz	28-400	HDPE	Andover Oblong	143.00
32 oz	38-400	HDPE	Exeter Oblong	144.00
32 oz	28-400	OPET	Super Grip Oblong	149.25
32 oz	28mm KERR Tamper Evident	OPET	Textured Square	149.90
32 oz	28-400	OPET	Textured Square	149.90
32 oz	32mm Bericap	OPET	Textured Square	149.90
32 oz	28-410	HDPE	Beveled Square	150.00
32 oz	28mm Tall	PVC	F Style Jug	152.00
32 oz	33-400	PVC / PETG	F Style Jug	152.00
32 oz	38-400	PVC / PETG	F Style Jug	152.00
32 oz	33-400	HDPE	F Style Jug	153.00
32 oz	38-400	HDPE	F Style Jug	153.00
32 oz	33-400	HDPE	Slant Handle F Style Jug	155.00
1 liter	28-400	OPET	Bullet Top Boston Round	6.50
1 liter	28-410	OPET	Bullet Top Boston Round	6.50
1 liter	28-410	OPET	Cosmo Round	6.60
1 liter	38-430	HDPE	Boston Round Buttress	20.50
1 liter	28-410	HDPE	TK Round	23.00
1 liter	28-400	OPET	Roman Round	30.25
1 liter	28mm Kerr Tamper Evident	OPET	Roman Round	30.25
1 liter	28-400	HDPE	Cone Top Round II	32.50
1 liter	28-410	PVC	Ringed Carafe	37.00
1 liter	28-400 Ramp	PVC	Ringed Ribbed Carafe	40.00
1 liter	28-400T	OPET	Hybrid Round	44.50
1 liter	28mm Ratchet	OPET	Hybrid Round	44.50
1 liter	28-400	OPET	MXR Round	44.75
1 liter	28mm KERR Tamper Evident	OPET	MXR Round	44.75

Remember, our product line is constantly changing...
Please call us if you do not see what you are looking for !!

INDEX

Size	Neck	Material	Description	Page #
1 liter	28-400	OPET	Jubilation Round	44.80
1 liter	28mm KERR Tamper Evident	OPET	Jubilation Round	44.80
1 liter	38-400	OPET	Jubilation II Round	44.85
1 liter	28-400	HDPE	Big Gripper	50.00
1 liter	28mm PS211	HDPE	Big Gripper	50.00
1 liter	28-410	HDPE	Modern Round	59.00
1 liter	38-400	HDPE	Modern Round	59.00
1 liter	53-400	HDPE	Packer Round	60.10
1 liter	28-410	PVC	Straight Sided Cylinder	67.00
1 liter	28-480	PVC	Straight Sided Cylinder	67.00
1 liter	28-410	HDPE	Straight Sided Cylinder	67.00
1 liter	38-400	HDPE	Straight Sided Cylinder	67.00
1 liter	48-400	HDPE	Straight Sided Cylinder	67.00
1 liter	28-400	OPET	Tall Slim Cylinder	68.00
1 liter	28-400	HDPE	#639 Additive Oval	74.00
1 liter	28-400	OPET	Pistol Gripper Sprayer Oval	87.20
1 liter	28-400	OPET	Ringed Grip Sprayer Oval	87.50
1 liter	28mm Ratchet	OPET	Ringed Grip Sprayer Oval	87.50
1 liter	28-400	OPET	Rounded Pistol Grip Sprayer Oval	88.00
1 liter	28mm Ratchet	OPET	Rounded Pistol Grip Sprayer Oval	88.00
1 liter	28-400 Ramp	HDPE	Twist Grip® 2000 Sprayer Oval	94.10
1 liter	28-400 Ramp	HDPE	Euro Twist Grip® Sprayer Oval	94.51
1 liter	28mm 6Ratchet	HDPE	Euro Twist Grip® Sprayer Oval	94.51
1 liter	28mm 8Ratchet	HDPE	Euro Twist Grip® Sprayer Oval	94.51
1 liter	28mm HP2/HP3 Hose End	HDPE	Euro Twist Grip® Sprayer Oval	94.51
1 liter	28-400 Ramp	HDPE	Premier Pistol Grip Sprayer Oval	94.75
1 liter	28mm 6Ratchet	HDPE	Premier Pistol Grip Sprayer Oval	94.75
1 liter	28mm 8Ratchet	HDPE	Premier Pistol Grip Sprayer Oval	94.75
1 liter	28mm HP2/HP3 Hose End	HDPE	Premier Pistol Grip Sprayer Oval	94.75
1 liter	33-400 Anti-Glug	HDPE	Klean-Pour® Handleware Oval	119.00
1 liter	28-400	OPET	Sierra Oblong	128.00
1 liter	28-400	HDPE	Center Neck Oblong w/Graduations	137.95
1 liter	28-400	HDPE	Offset Neck Oblong	139.00
1 liter	28-400	PVC	Offset Neck Oblong	140.00

Remember, our product line is constantly changing....

20

Please call us if you do not see what you are looking for !!

INDEX

Size	Neck	Material	Description	Page #
1 liter	33-400	PVC	Offset Neck Oblong	140.00
1 liter	28-400	PVC	Octane Oblong	140.50
1 liter	28-400	PVC	Center Neck Oblong	141.00
1 liter	33-400	PVC	Center Neck Oblong	141.00
1 liter	28-400	PVC	Brickyard Oblong	141.50
1 liter	38-400	HDPE	Daytona Oblong	142.00
1 liter	28-400	HDPE	Andover Oblong	143.00
1 liter	38-400	HDPE	Exeter Oblong	144.00
1 liter	28mm KERR Tamper Evident	OPET	Textured Square	149.90
1 liter	28-400	OPET	Textured Square	149.90
1 liter	32mm Bericap	OPET	Textured Square	149.90
1 liter	28-410	HDPE	Beveled Square	150.00
1 liter	38-400	HDPE	F Style Jug	153.10
1 liter	33-400	HDPE	Slant Handle F Style Jug	155.00
34 oz	89-400	HDPE	Modified Round	60.50
34 oz	81mm Snap On Finish	HDPE	Round Canister with Lid	60.60
40 oz	28-400 Ramp	HDPE	Rounded Pistol Grip Sprayer Oval	88.25
40 oz	28mm Ratchet	HDPE	Rounded Pistol Grip Sprayer Oval	88.25
42 oz	28P100	PVC / HDPE	Rondout Handleware Oval	107.00
42 oz	28-400	HDPE	Rondout Handleware Oval	107.00
48 oz	38-400	OPET	Super Grip Oblong	149.25
48 oz	63-485 Tall	HDPE	Handleware Oblong	149.30
56 oz	105mm Snap On Finish	HDPE	Round Canister with Lid	60.60
64 oz	51mm Berry Cap & Spout	HDPE	Handleware Round	50.50
64 oz	38-400	HDPE	High Handle Half Industrial Round	51.00
64 oz	33-400 Anti-Glug	HDPE	Klean-Pour® Handleware Oval	119.00
64 oz	33-400 Anti-Glug	HDPE	Klean-Pour® II Handleware Oval	120.00
64 oz	28-410	HDPE	Award Handleware Oval	121.00

Remember, our product line is constantly changing...
Please call us if you do not see what you are looking for !!

INDEX

Size	Neck	Material	Description	Page #
64 oz	38-400	OPET	Super Grip Oblong	149.25
64 oz	28-400 .485"	PVC	F Style Jug	152.10
64 oz	28mm Tall	PVC	F Style Jug	152.10
64 oz	28mm .515"	PVC	F Style Jug	152.10
64 oz	38-400	PVC	F Style Jug	152.10
64 oz	33-400	HDPE	F Style Jug with Graduations	154.00
64 oz	38-400	HDPE	F Style Jug with Graduations	154.00
64 oz	38-400	HDPE	F Style Jug-Tall	154.50
64 oz	28-480	PVC	Industrial Square Jug	157.00
64 oz	38-400	PVC	Industrial Square Jug	157.00
64 oz	38-400	OPET	Sure Grip Square	158.00
2 liter	43mm Menshen one2dose	HDPE	Handleware Round	50.50
2 liter	51mm Berry Cap & Spout	HDPE	Handleware Round	50.50
2 liter	33-400 Anti-Glug	HDPE	Klean-Pour® Handleware Oval	119.00
2 liter	33-400 Anti-Glug	HDPE	Klean-Pour® II Handleware Oval	120.00
2 liter	33-400	HDPE	F Style Jug with Graduations	154.00
2 liter	38-400	HDPE	F Style Jug with Graduations	154.00
2 liter	110MM Pano Tamper Evident	HDPE	Wide Mouth Square	156.50
2 liter	28-480	PVC	Industrial Square Jug	157.00
2 liter	38-400	PVC	Industrial Square Jug	157.00
2 liter	38-400	OPET	Sure Grip Square	158.00
75 oz	100-400	HDPE	Wide Mouth Round	61.00
100 oz	38-400	OPET	Sure Grip Square	158.10
3 liter	38-400	HDPE	F Style Jug	153.10
128 oz	33-400	HDPE	Great Lakes Handleware Oblong	149.50
128 oz	38-400	HDPE	Great Lakes Handleware Oblong	149.50
128 oz	28mm Tall	PVC	F Style Jug	152.10
128 oz	38-400	PVC	F Style Jug	152.10
128 oz	33-400	HDPE	Slant Handle F Style Jug	156.00

Remember, our product line is constantly changing...
Please call us if you do not see what you are looking for !!

INDEX

Size	Neck	Material	Description	Page #
128 oz	38-400	HDPE	Slant Handle F Style Jug	156.00
128 oz	53-400	HDPE	Slant Handle F Style Jug	156.00
128 oz	63-485 Rieke	HDPE	Slant Handle F Style Jug	156.00
128 oz	38-400	HDPE	Gripped Slant Handle F Style Jug	156.10
128 oz	38-400	PVC	Industrial Square Jug	157.00
128 oz	48mm Bericap	OPET	Sure Square	158.20
128 oz	33-400	HDPE	Great Plains Industrial Square Jug	159.00
128 oz	38-400	HDPE	Great Plains Industrial Square Jug	159.00
4 liter	33-400	HDPE	Great Lakes Handleware Oblong	149.50
4 liter	38-400	HDPE	Great Lakes Handleware Oblong	149.50
4 liter	33-400	HDPE	Slant Handle F Style Jug	156.00
4 liter	38-400	HDPE	Slant Handle F Style Jug	156.00
4 liter	53-400	HDPE	Slant Handle F Style Jug	156.00
4 liter	63-485 Rieke	HDPE	Slant Handle F Style Jug	156.00
4 liter	38-400	HDPE	Gripped Slant Handle F Style Jug	156.10
4 liter	38-400	PVC	Industrial Square Jug	157.00
4 liter	48mm Bericap	OPET	Sure Square	158.20
160 oz	38-400	HDPE	Gripped Slant Handle F Style Jug	156.10
5 liter	38-400	HDPE	Gripped Slant Handle F Style Jug	156.10
2.5 gallon	63mm AntiGlug	HDPE	Slant Handle F Style Jug	156.40
10 liter	63mm AntiGlug	HDPE	Slant Handle F Style Jug	156.40

Remember, our product line is constantly changing....
Please call us if you do not see what you are looking for !!



ROUNDS

Where great ideas take shape.

BULLET TOP BOSTON ROUNDS

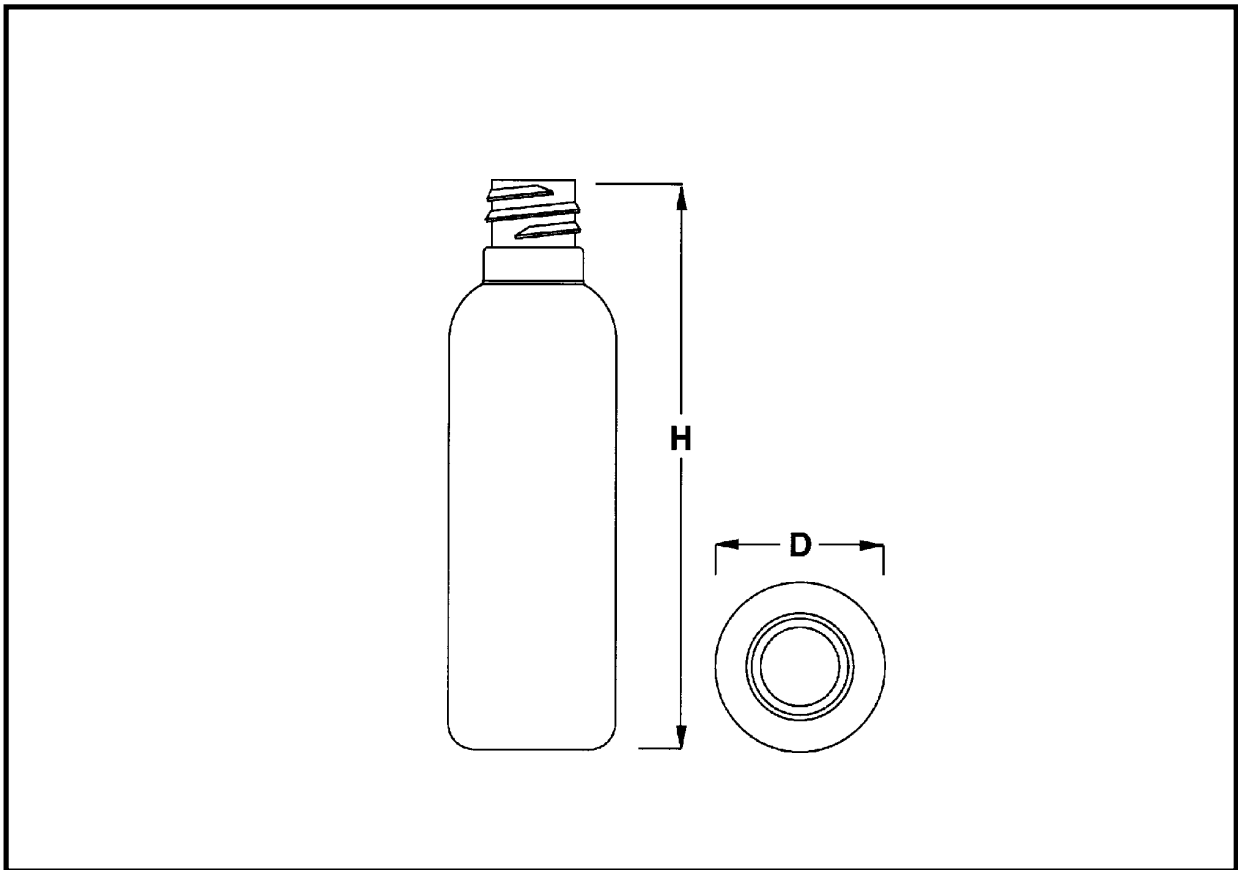

BULLET TOP BOSTON ROUNDS

CAPACITY	NECKS	MATERIAL	HEIGHT	DIAMETER
2 / 2.20 oz	18 - 415	PVC	4.20"	1.29"
2 / 2.20 oz	20 - 410	PVC	4.02"	1.29"
2 / 2.20 oz	20 - 415	PVC	4.20"	1.29"
4 / 4.52 oz	24 - 410	PVC	5.50"	1.54"
4 / 4.52 oz	24 - 415	PVC	5.83"	1.54"

Secondary capacity measurement represents cosmetic fill point to base of neck.

BULLET TOP BOSTON ROUNDS

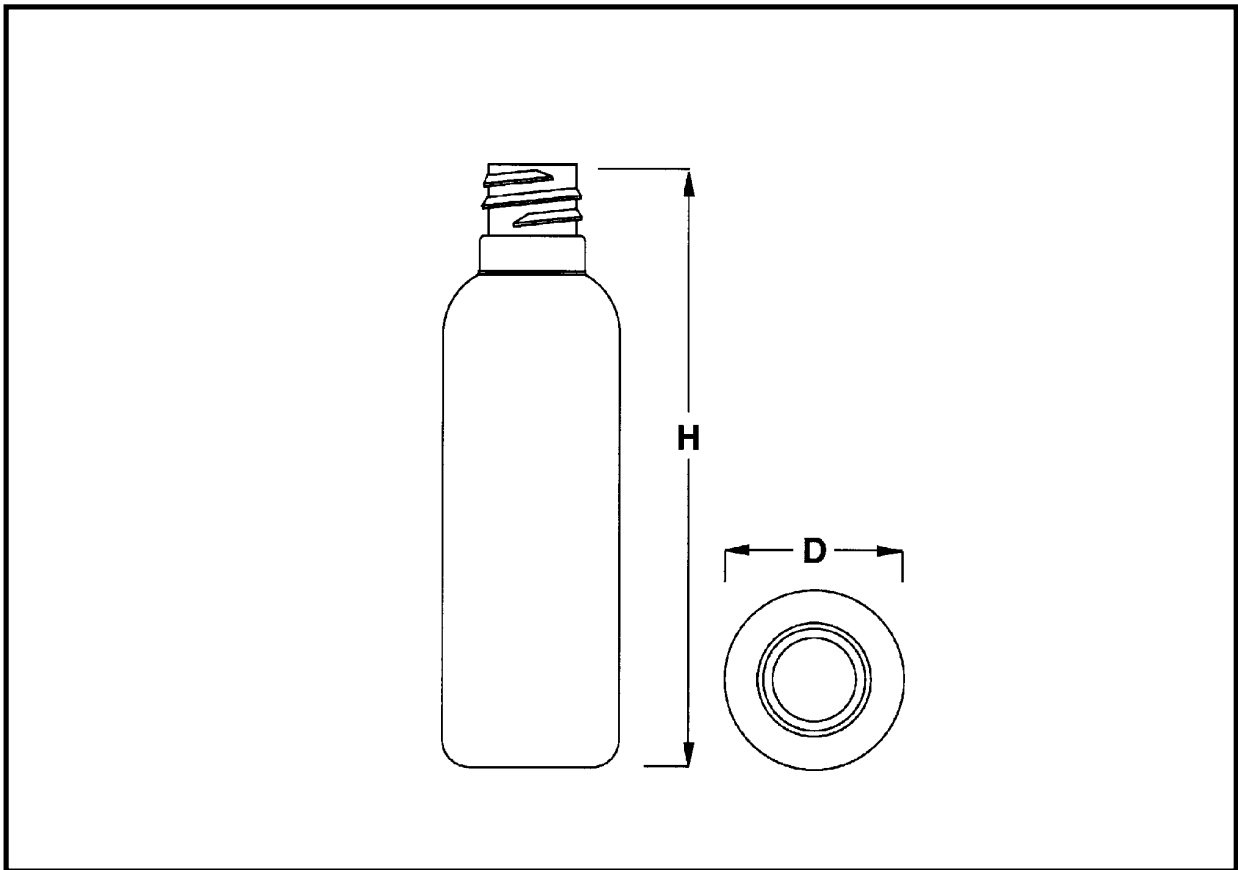

BULLET TOP BOSTON ROUNDS

CAPACITY	NECKS	MATERIAL	HEIGHT	DIAMETER
7 / 7.18 oz	20mm Crimp**	PVC	5.58"	1.93"
7 / 7.18 oz	20mm PVCrimp*	PVC	5.52"	1.93"
7 / 7.18 oz	22-415	PVC	5.92"	1.93"
7 / 7.18 oz	24-415	PVC	5.92"	1.93"

Secondary capacity measurement represents cosmetic fill point to base of neck.

** Works with Emson Crimp neck pump

* Works with Precision Valve Crimp neck pump

BULLET TOP BOSTON ROUNDS

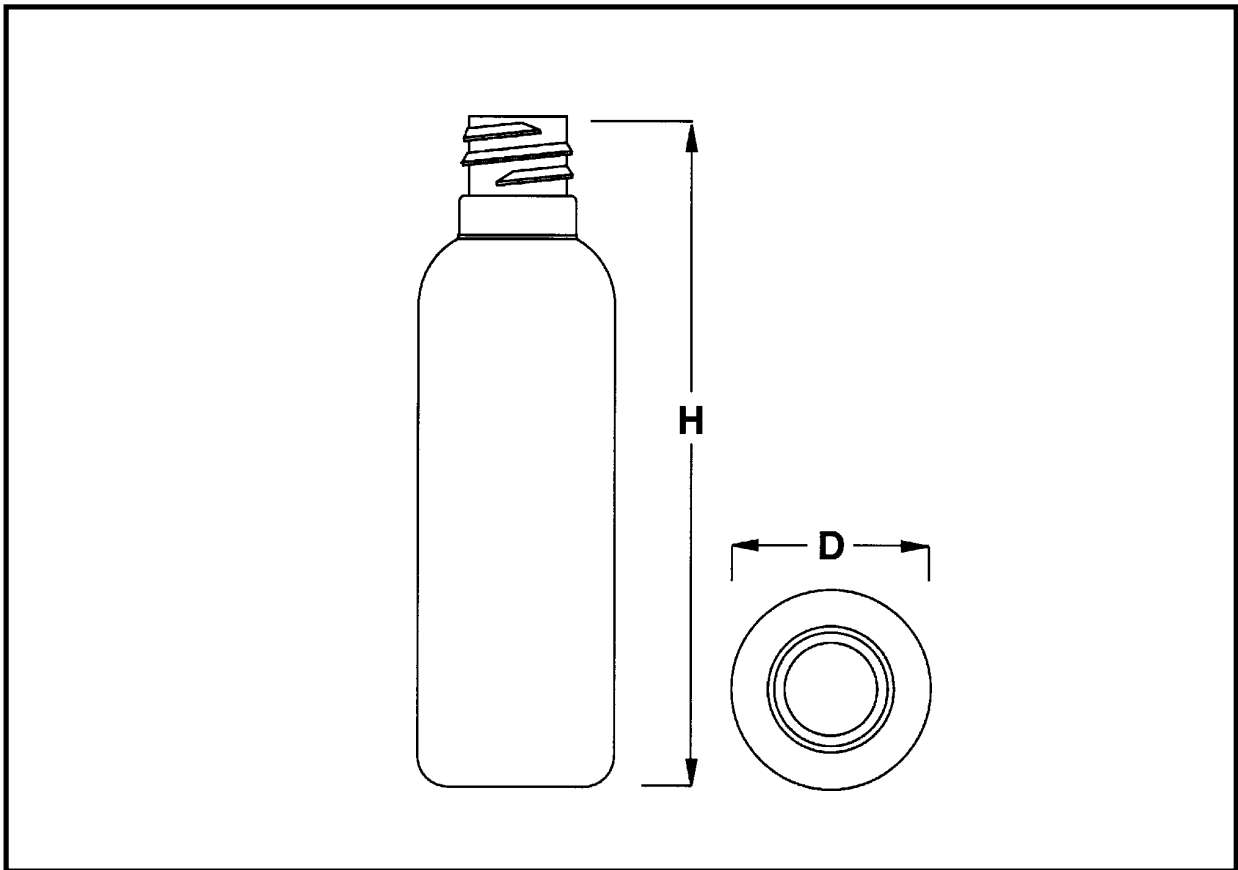

BULLET TOP BOSTON ROUNDS

CAPACITY	NECKS	MATERIAL	HEIGHT	DIAMETER
8 / 8.8 oz	24 - 410	PVC	6.85"	1.90"
8 / 8.8 oz	24 - 415	PVC	7.15"	1.90"

Secondary capacity measurement represents cosmetic fill point to base of neck.

BULLET TOP BOSTON ROUNDS

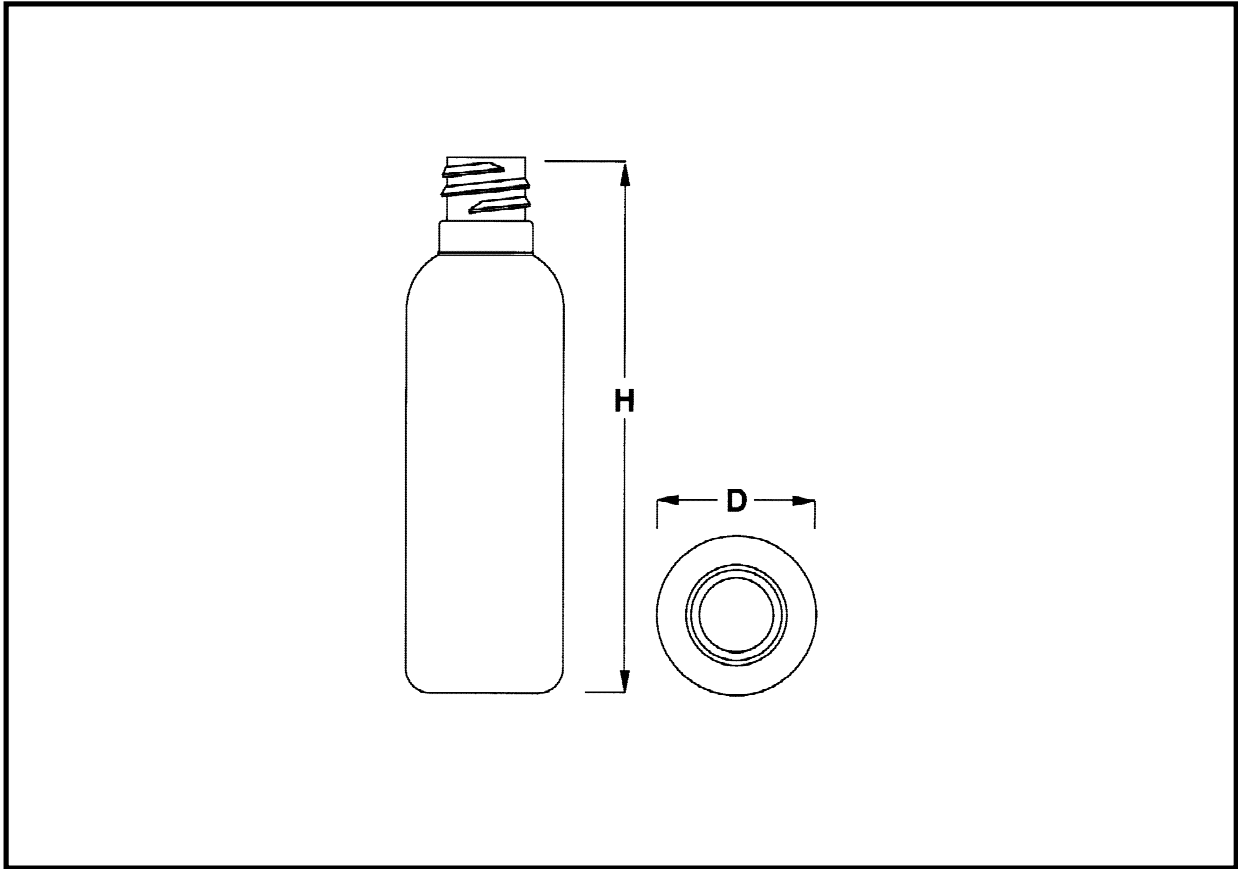

BULLET TOP BOSTON ROUNDS

CAPACITY	NECKS	MATERIAL	HEIGHT	DIAMETER
2 oz	24-410	HDPE or LDPE	3.655"	1.365"
4 oz	24-410	HDPE	5.375"	1.55"
8 oz	24-410	HDPE	6.604"	1.947"
16 oz	24-410	HDPE	7.733"	2.46"
16 oz	24-415	HDPE	7.733"	2.46"
16 oz	28-410	HDPE	7.703"	2.46"

BULLET TOP BOSTON ROUNDS

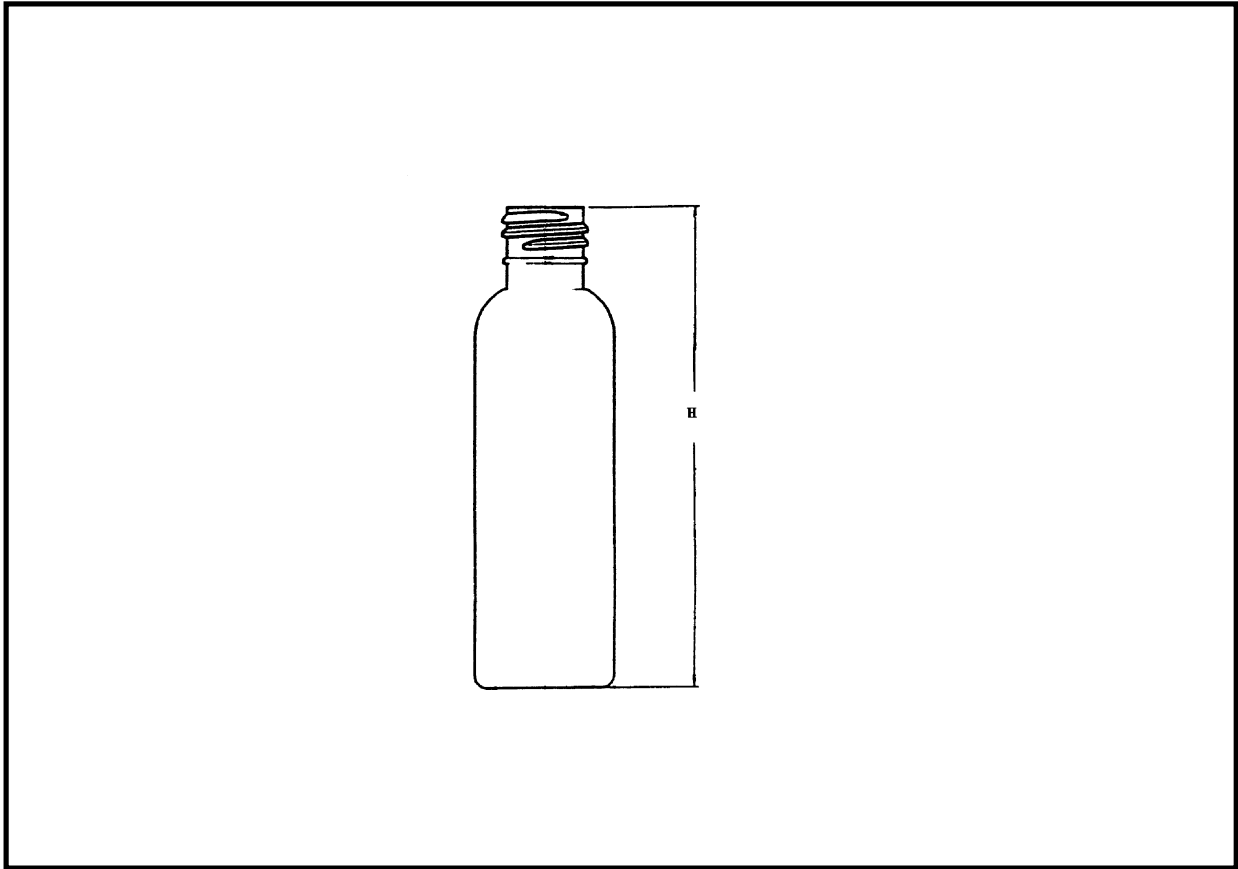

BULLET TOP BOSTON ROUNDS

CAPACITY	NECKS	MATERIAL	HEIGHT	DIAMETER
2 oz	20-410	OPET	4.114"	1.264"
2 oz	20-415	OPET	4.299"	1.264"
4 oz	20-410	OPET	5.366"	1.551"
4 oz	20-415	OPET	5.551"	1.551"
4 oz	24-410	OPET	5.394"	1.551"

BULLET TOP BOSTON ROUNDS

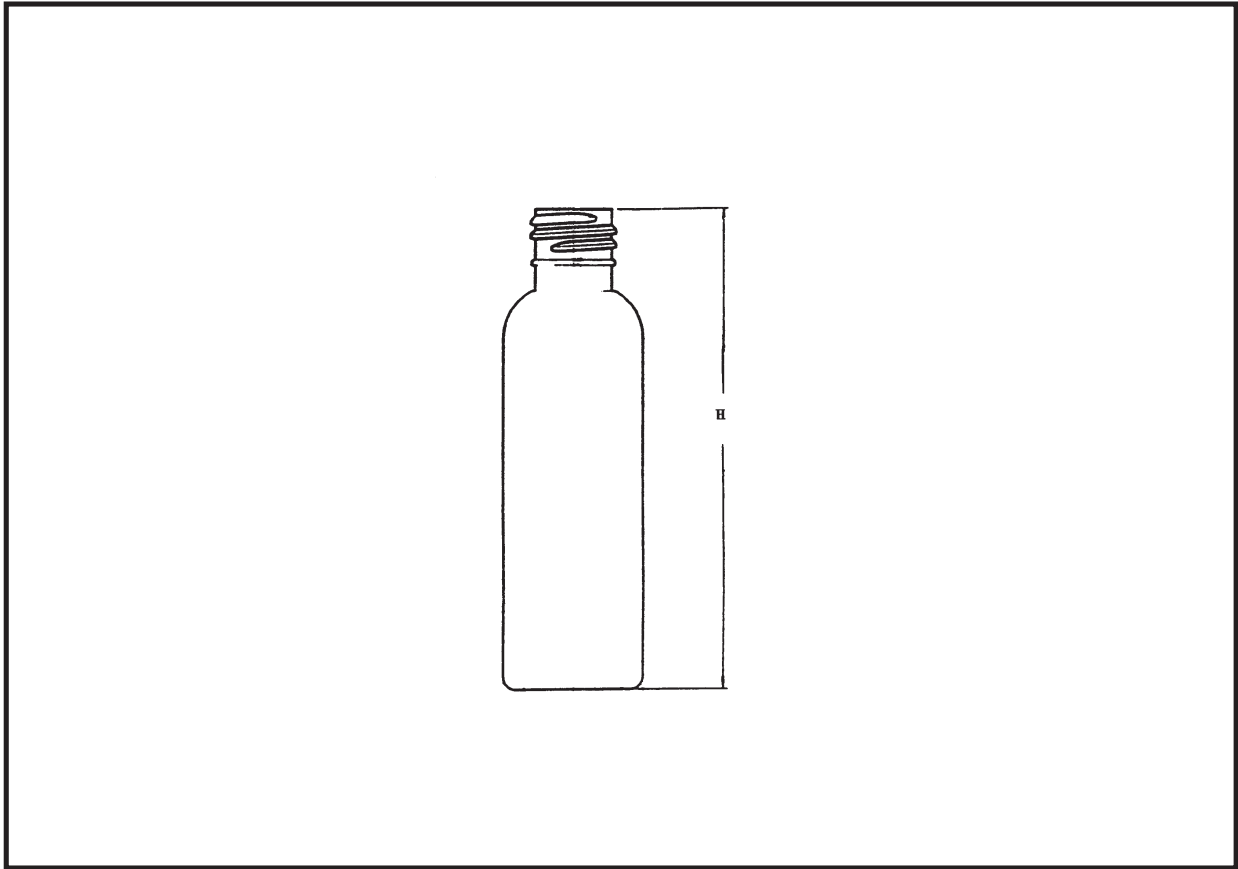

BULLET TOP BOSTON ROUNDS

CAPACITY	NECKS	MATERIAL	HEIGHT	DIAMETER
6 oz	24-410	OPET	6.146"	1.72"
6 oz	24-415	OPET	6.457"	1.72"
8 oz	24-410	OPET	6.85"	1.90"
8 oz	24-415	OPET	7.15"	1.90"
8 oz	24-410	OPET	6.813"	1.862"
8 oz	24-415	OPET	7.124"	1.862"
12 oz	24-410	OPET	7.134"	2.193"
12 oz	24-415	OPET	7.445"	2.193"

BULLET TOP BOSTON ROUNDS

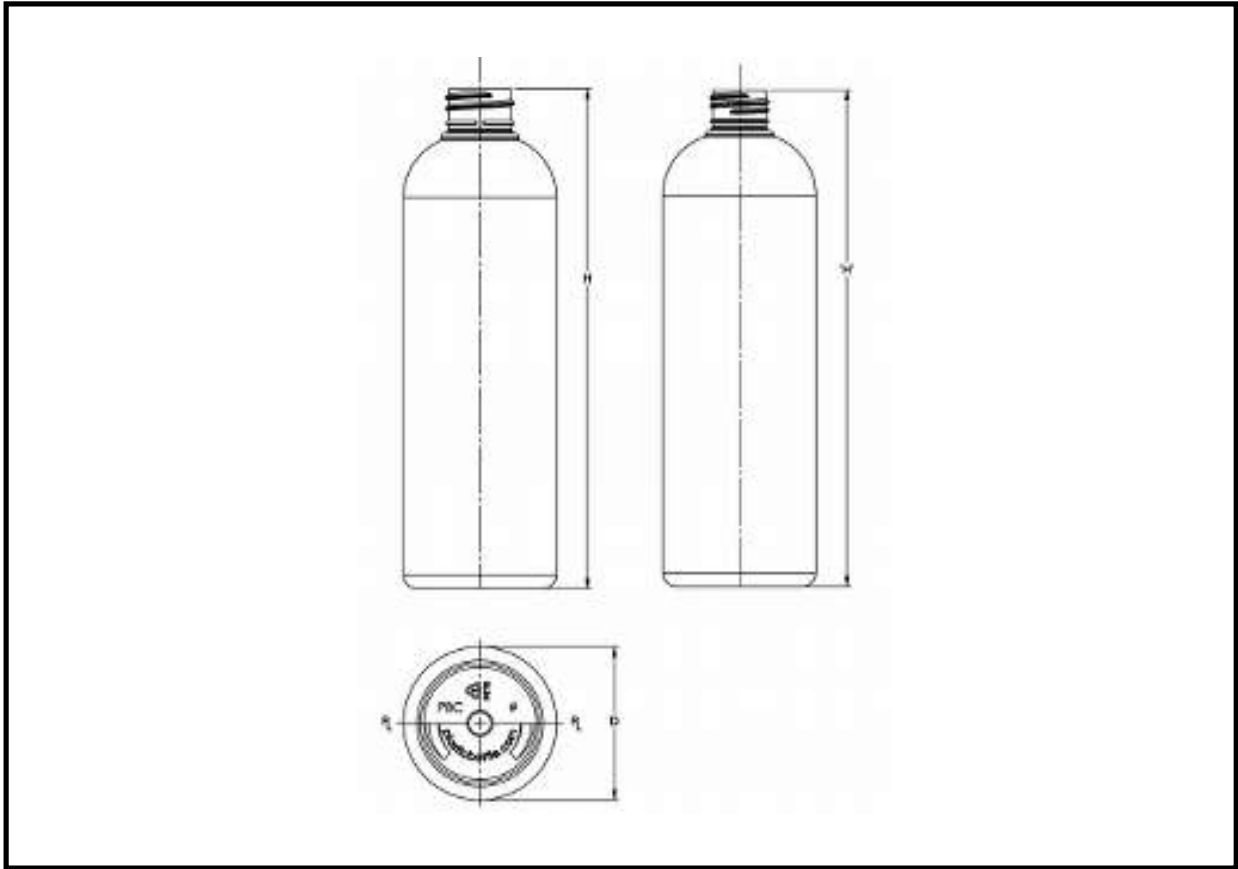

BULLET TOP BOSTON ROUNDS

CAPACITY	NECKS	MATERIAL	HEIGHT	DIAMETER
16 oz	24-410	OPET	7.913"	2.44"
16 oz	28-410	OPET	7.963"	2.44"
16 oz	28-410	PVC	7.963"	2.44"
16 oz	28-415	OPET	8.337"	2.44"

BULLET TOP BOSTON ROUNDS

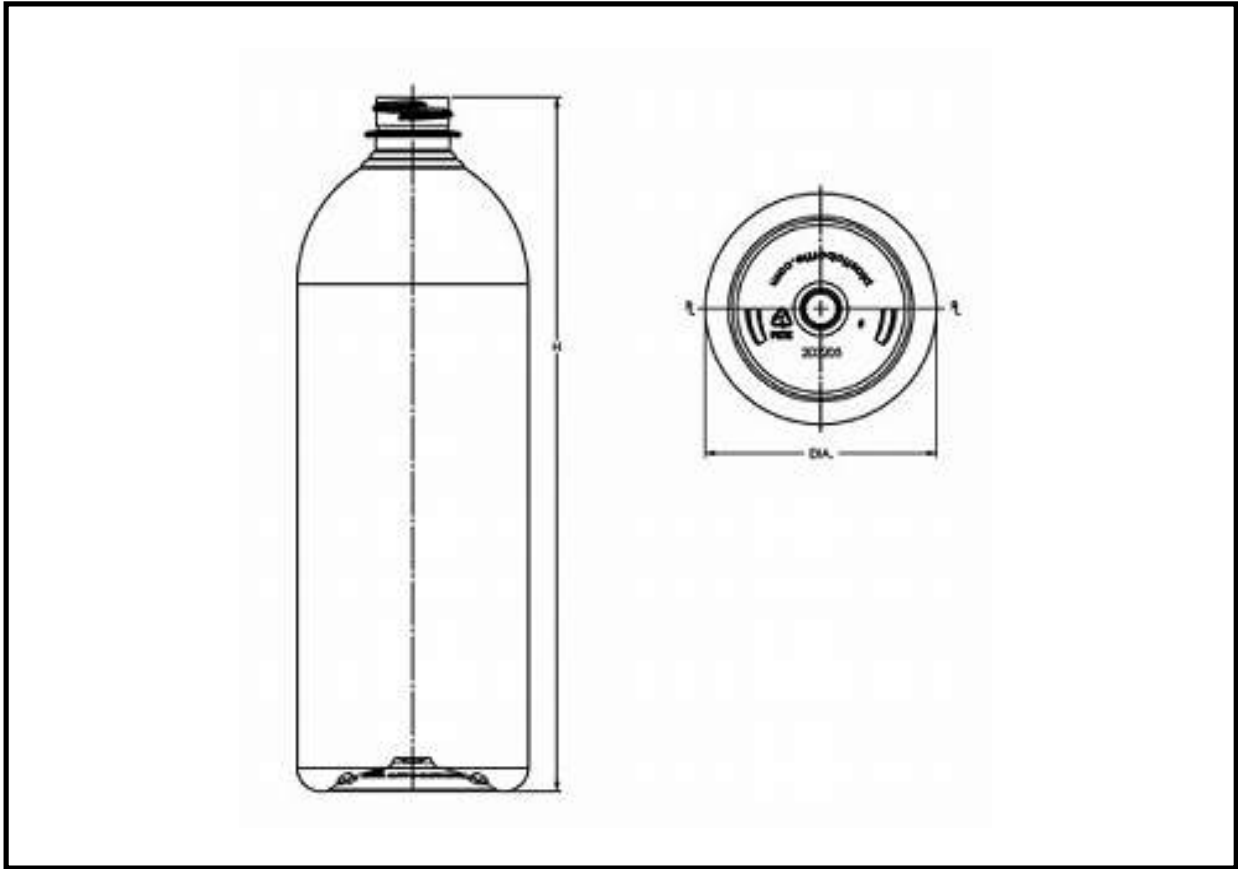

BULLET TOP BOSTON ROUNDS

CAPACITY	NECKS	MATERIAL	HEIGHT	DIAMETER
32 oz	28-400 .460" H	OPET	9.455"	3.150"
32 oz	28-400 .475" H	OPET	9.440"	3.150"
32 oz	28-410	OPET	9.715"	3.150"
1 Liter	28-400 .460" H	OPET	9.843"	3.150"
1 Liter	28-400 .475" H	OPET	9.843"	3.150"
1 Liter	28-410	OPET	10.105"	3.150"

COSMO ROUNDS

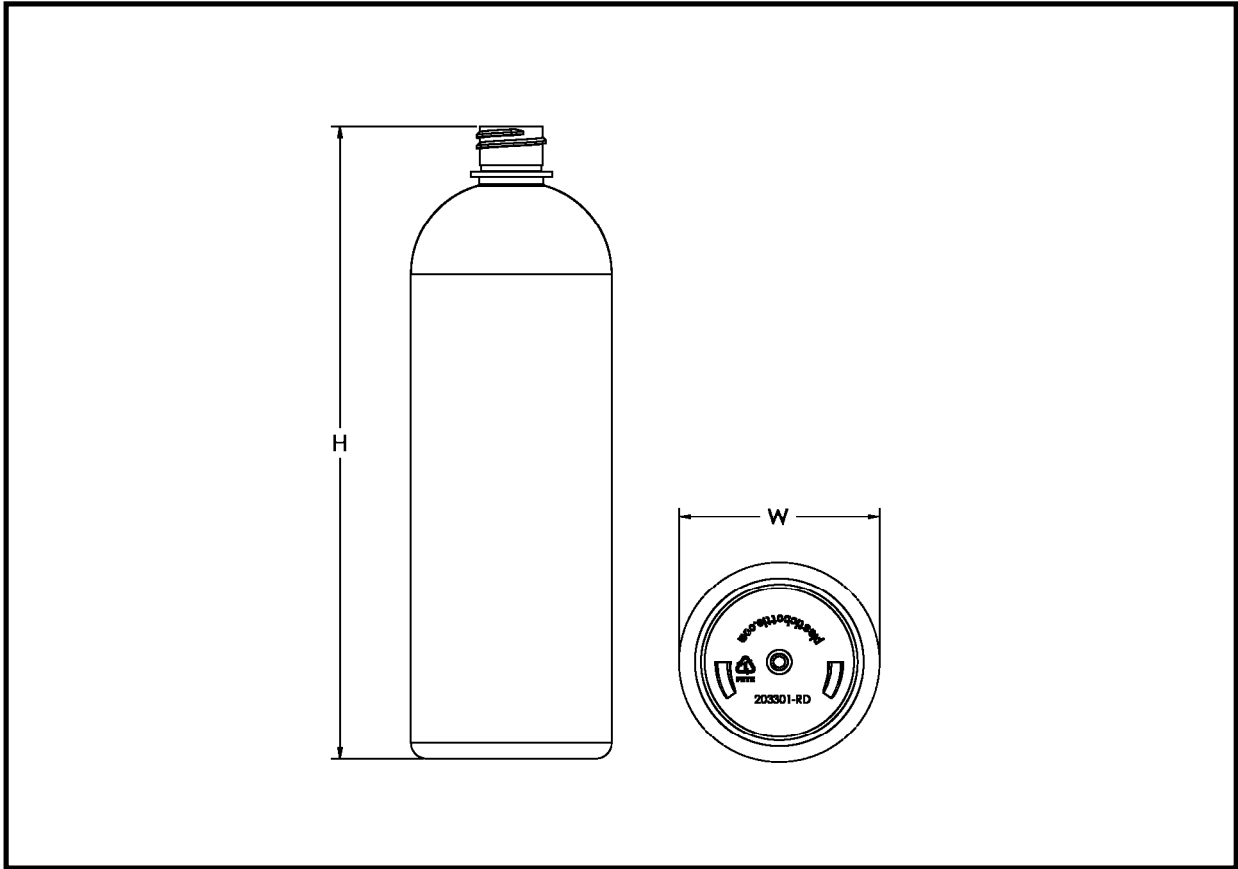

COSMO ROUNDS

CAPACITY	NECKS	MATERIAL	HEIGHT	DIAMETER
32 oz / 1 Liter	28-410	OPET	9.873"	3.135"

FOOTED BULLET TOP BOSTON ROUNDS

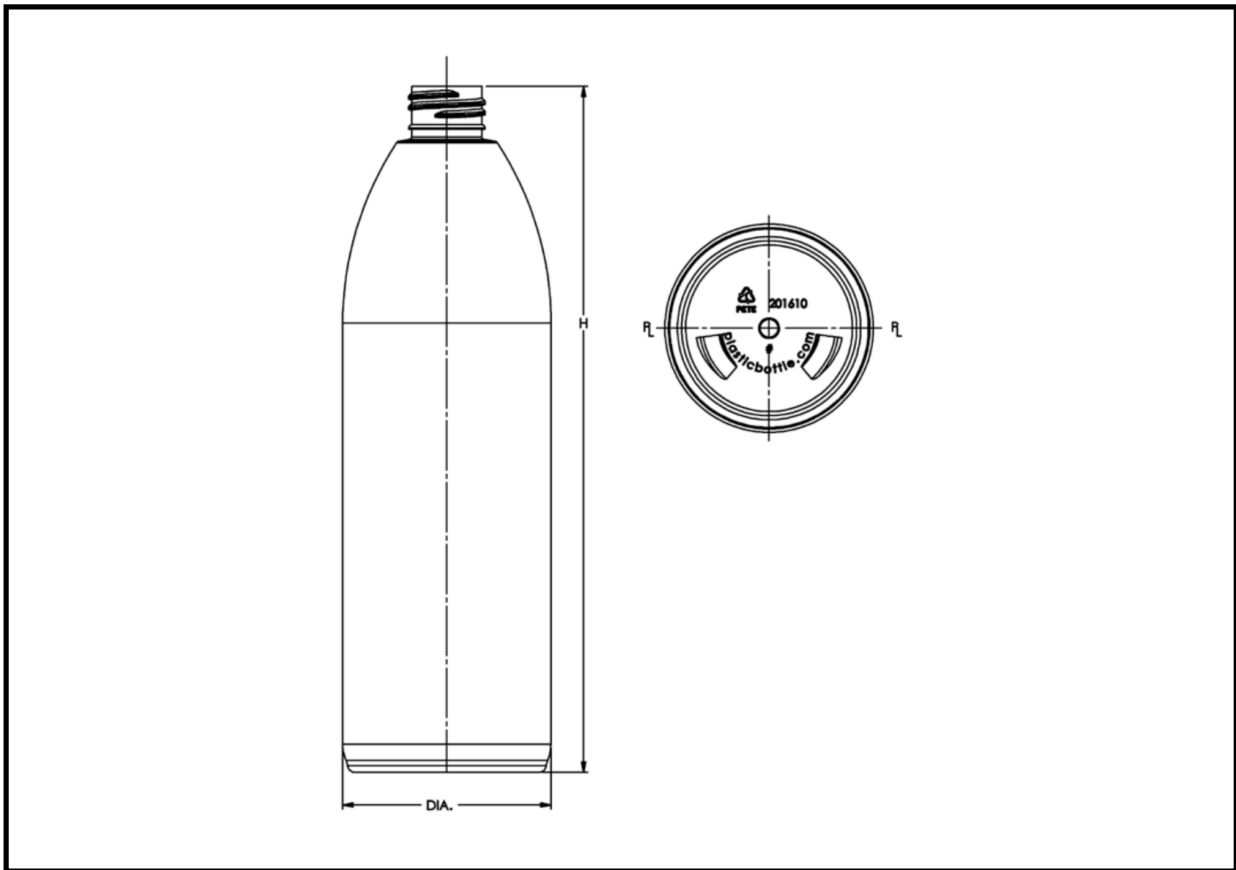

FOOTED BULLET TOP BOSTON ROUNDS

CAPACITY	NECKS	MATERIAL	HEIGHT	DIAMETER
2 oz	24-410	OPET	3.51"	1.44"
250 ml	28-410	OPET	6.335"	2.052"
16 oz / 500 ml	28-410	OPET	8.205"	2.525"
16 oz / 500 ml	28-415	OPET	8.579"	2.525"
18 oz*	28-410	OPET	8.365"	2.550"
18 oz*	28-415	OPET	8.729"	2.550"

*Some restrictions apply

ROCKY ROUND

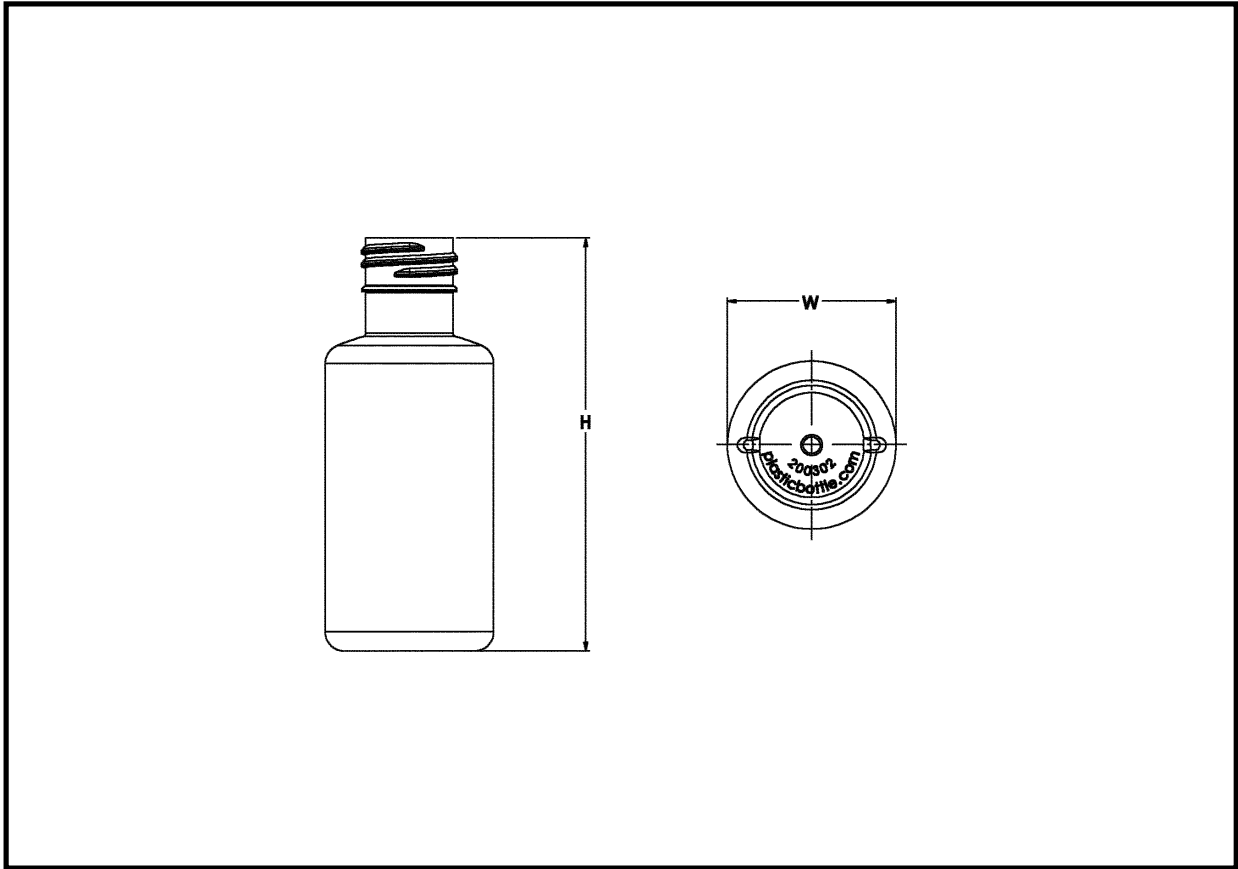

ROCKY ROUND

CAPACITY	NECKS	MATERIAL	HEIGHT	DIAMETER
3 oz	24-410	OPET	3.694"	1.635"
3 oz	24-415	OPET	4.005"	1.635"

BOSTON ROUNDS

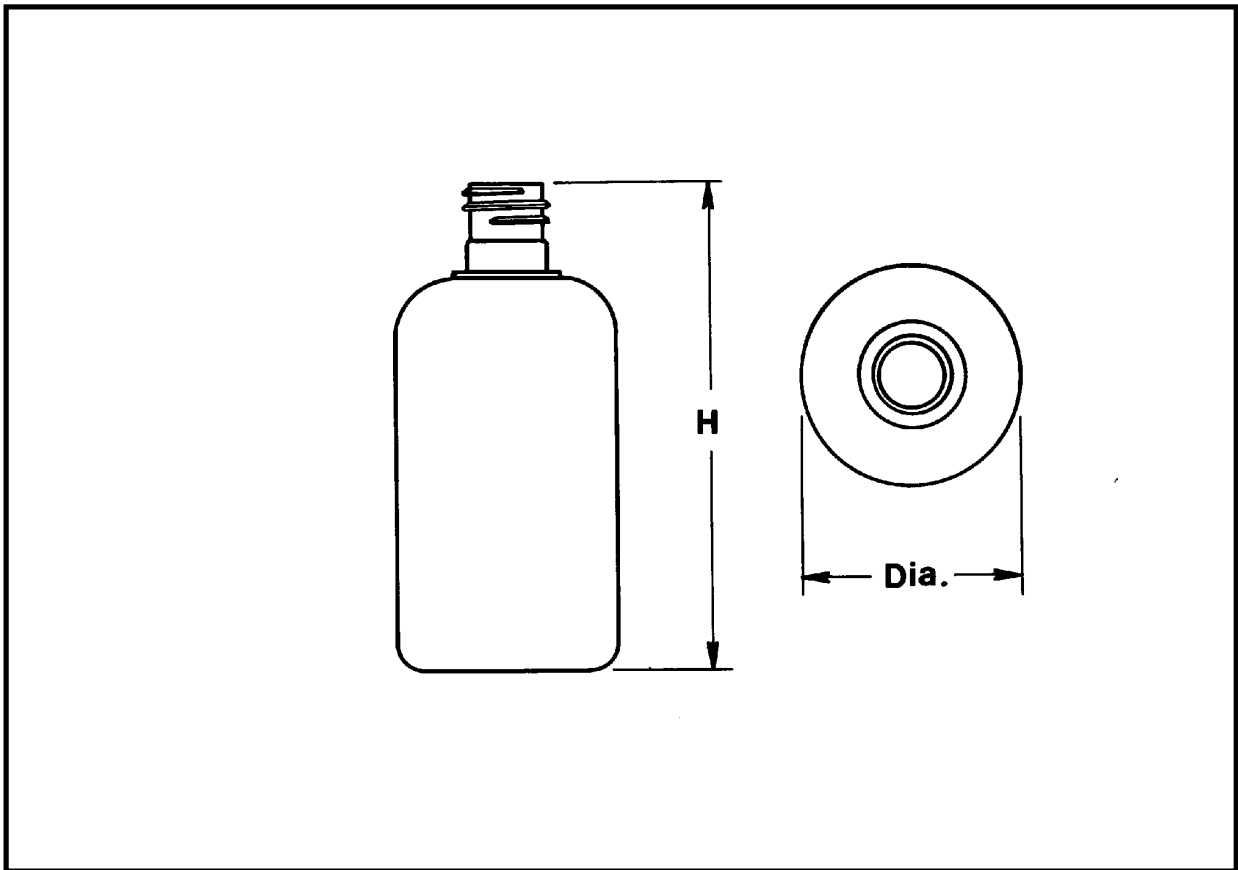

BOSTON ROUNDS

CAPACITY	NECKS	MATERIAL	HEIGHT	DIAMETER
2 1/2.56 oz	20-415	PVC	3.56"	1.55"
3 oz	20-410	OPET	3.455"	1.735"
3 oz	20-415	OPET	3.643"	1.735"
4 1/4.28 oz	24-410	PVC	3.91"	1.85"
4 1/4.28 oz	24-415	PVC	4.24"	1.85"

Secondary capacity measurement represents cosmetic fill point to base of neck.

BOSTON ROUNDS

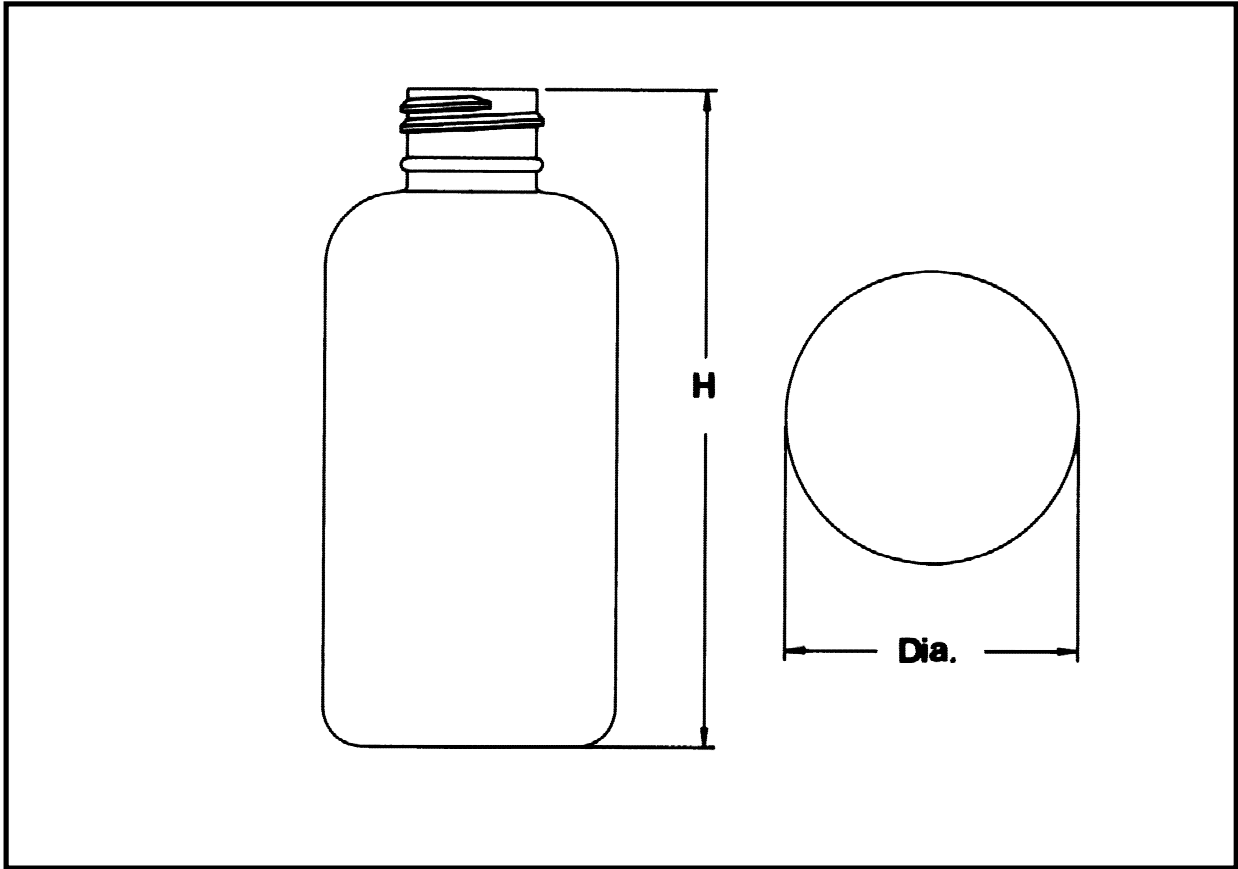

BOSTON ROUNDS

CAPACITY	NECKS	MATERIAL	HEIGHT	DIAMETER
8 / 8.60 oz	24-410	PVC	4.98"	2.28"
8 / 8.60 oz	24-415	PVC	5.29"	2.28"

Secondary capacity measurement represents cosmetic fill point to base of neck.

BOSTON ROUNDS

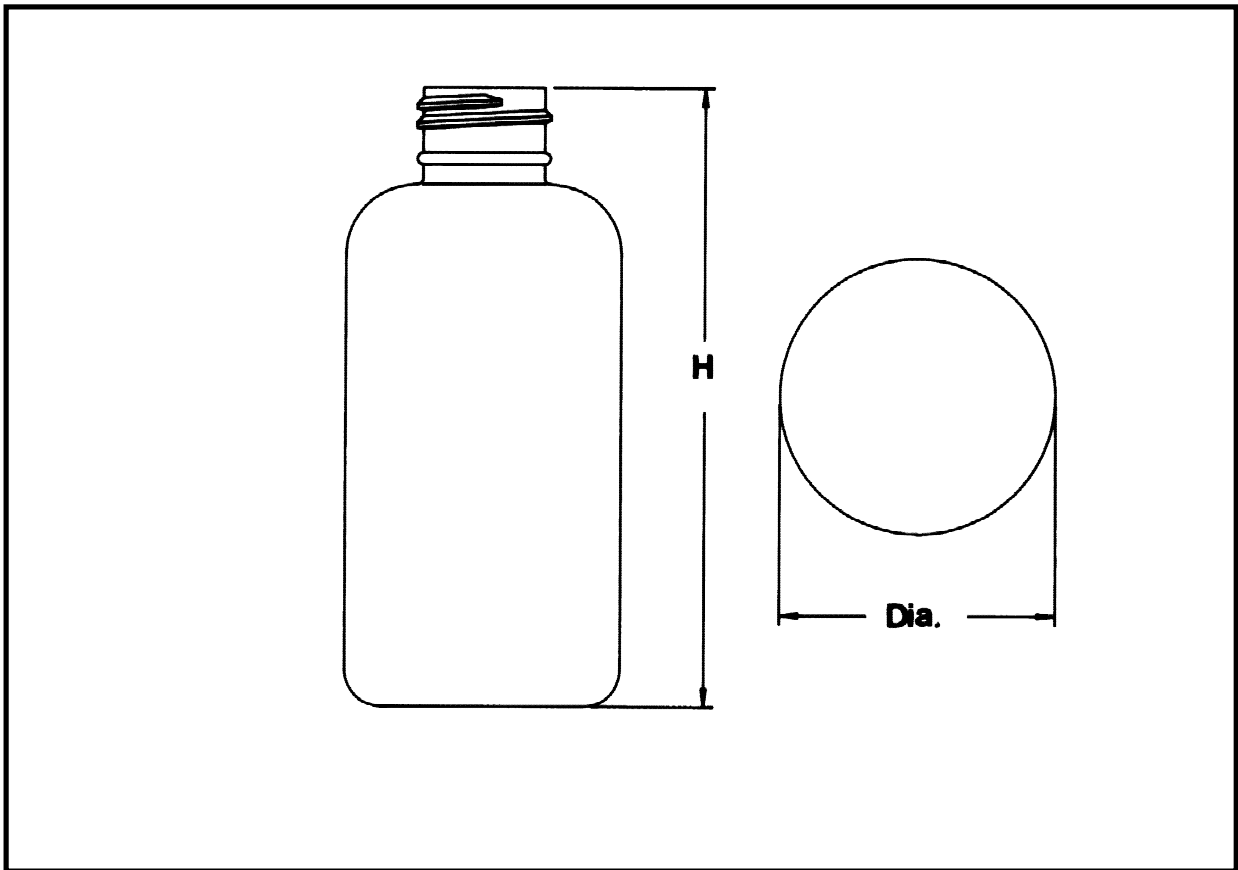

BOSTON ROUNDS

CAPACITY	NECKS	MATERIAL	HEIGHT	DIAMETER
1 oz	24-410	HDPE or LDPE	2.375"	1.365"
4 oz*	24-400**	HDPE	4.24"	1.88"
4 oz*	24-410	HDPE	4.24"	1.88"
8 oz*	24-410	HDPE	5.162"	2.322"
12 oz	28-410	HDPE	6.34"	2.45"
19 oz*	24-410	HDPE	7.907"	2.765"

*Available with or without view stripe

** Tamper Evident Bead

FOOTED BOSTON ROUND

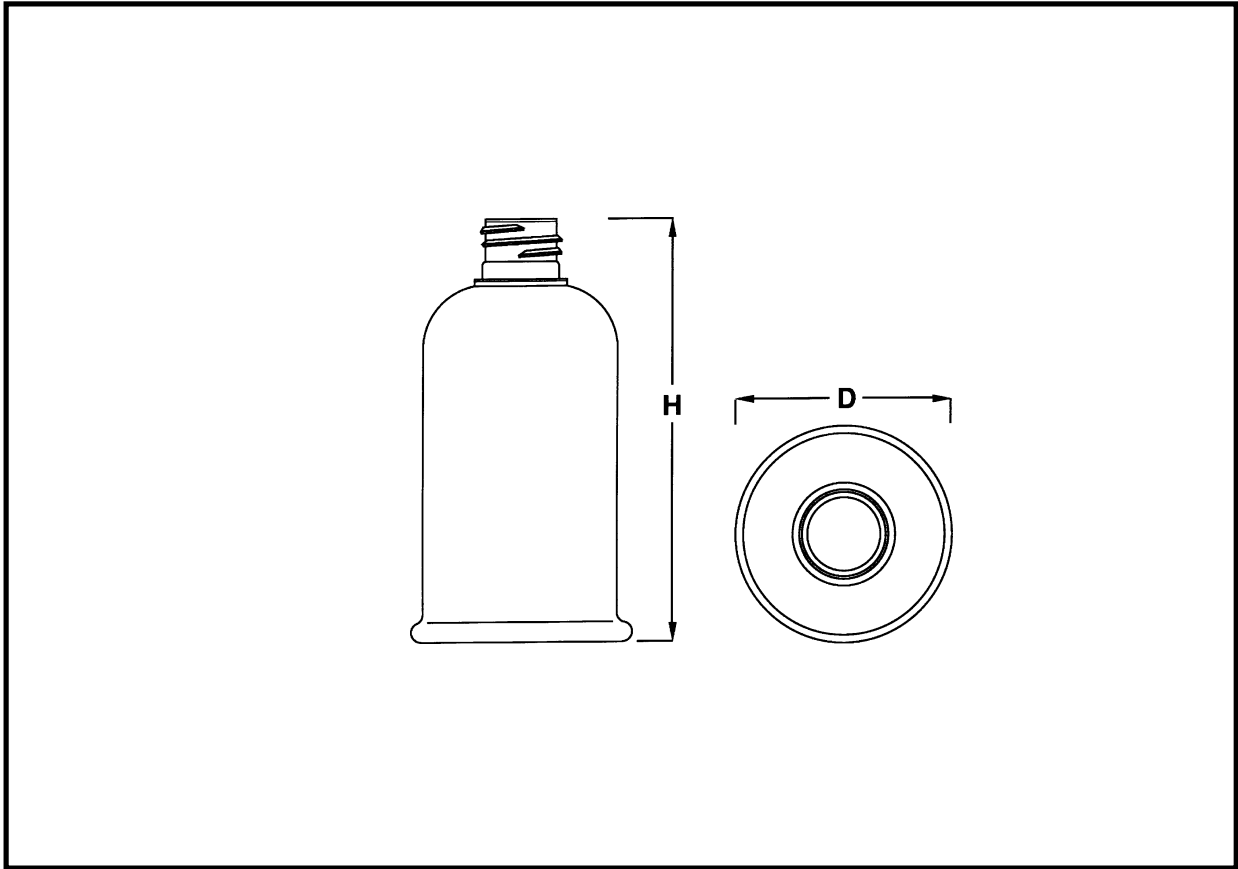

FOOTED BOSTON ROUND

CAPACITY	NECKS	MATERIAL	HEIGHT	DIAMETER
8 / 8.72 oz	24-410	PVC	4.93"	2.49"
8 / 8.72 oz	24-415	PVC	5.30"	2.49"

Secondary capacity measurement represents cosmetic fill point to base of neck.
 For a 50,000 piece order, we could look at building an OPET version.

CHESHIRE ROUNDS

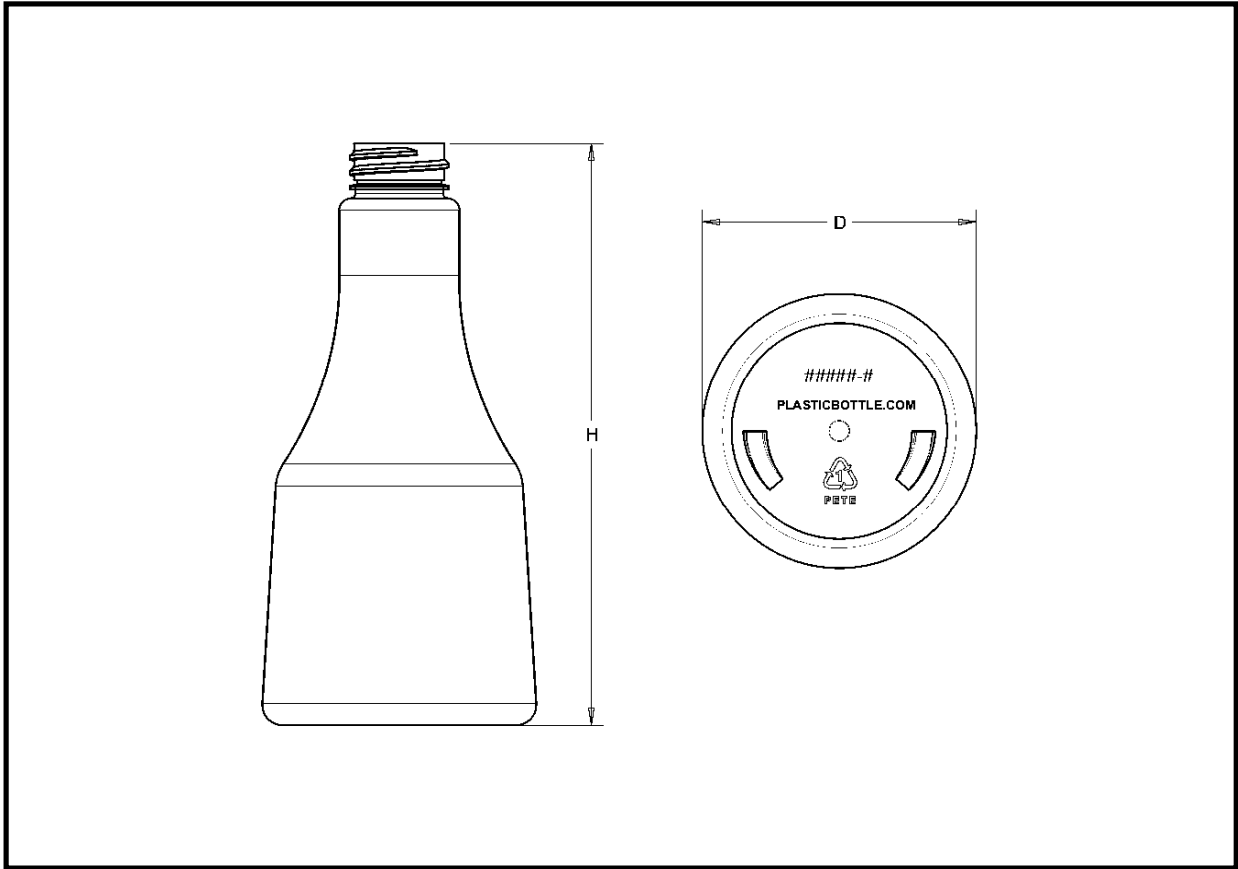

CHESHIRE ROUNDS

CAPACITY	NECKS	MATERIAL	HEIGHT	DIAMETER
12 oz	28-410 Low H .597" H	OPET	6.348"	2.99"
12 oz	28mm Ratchet	OPET	6.43"	2.99"

VENUS ROUNDS

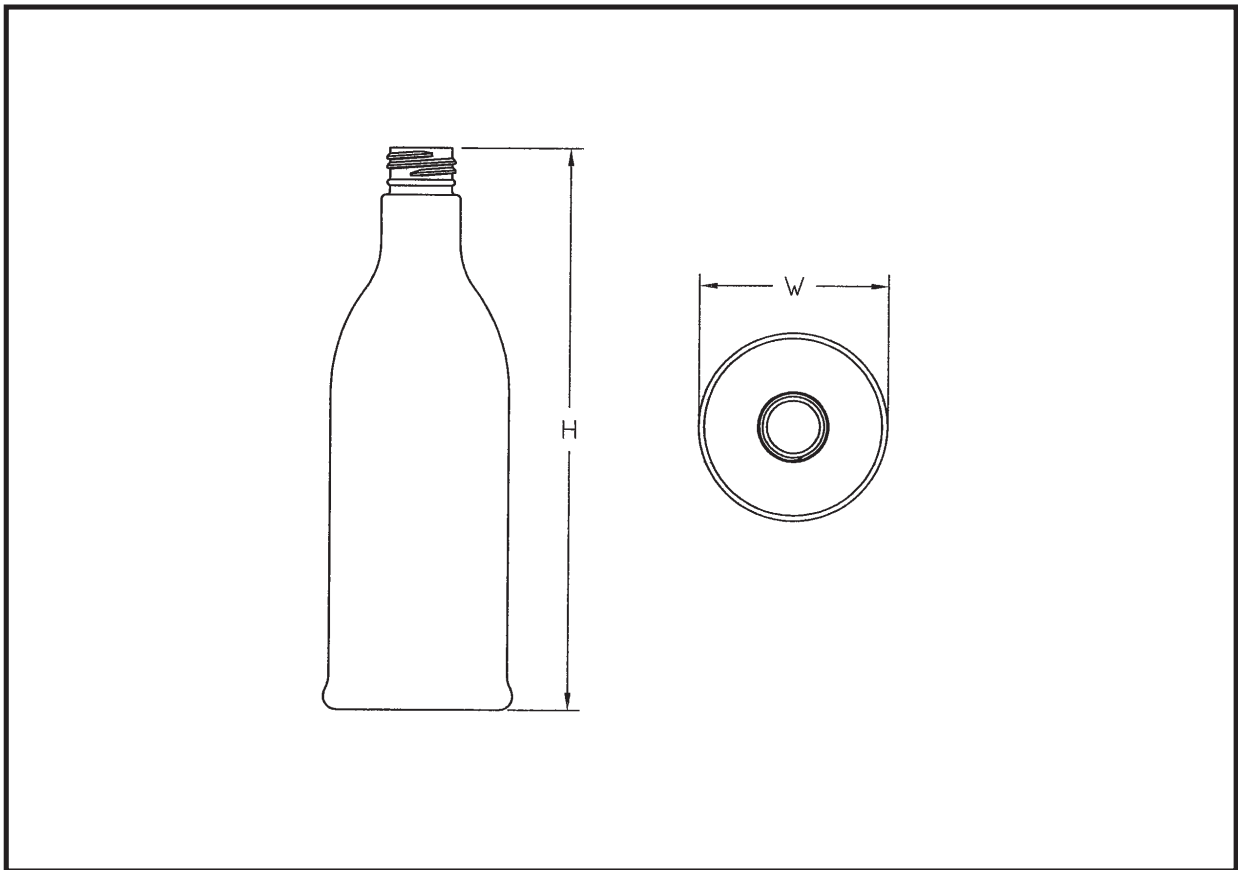

VENUS ROUNDS

CAPACITY	NECKS	MATERIAL	HEIGHT	DIAMETER
400 ml	24-410	OPET	7.75"	2.598"
400 ml	24-415	OPET	8.061"	2.598"

CAPITOL ROUNDS

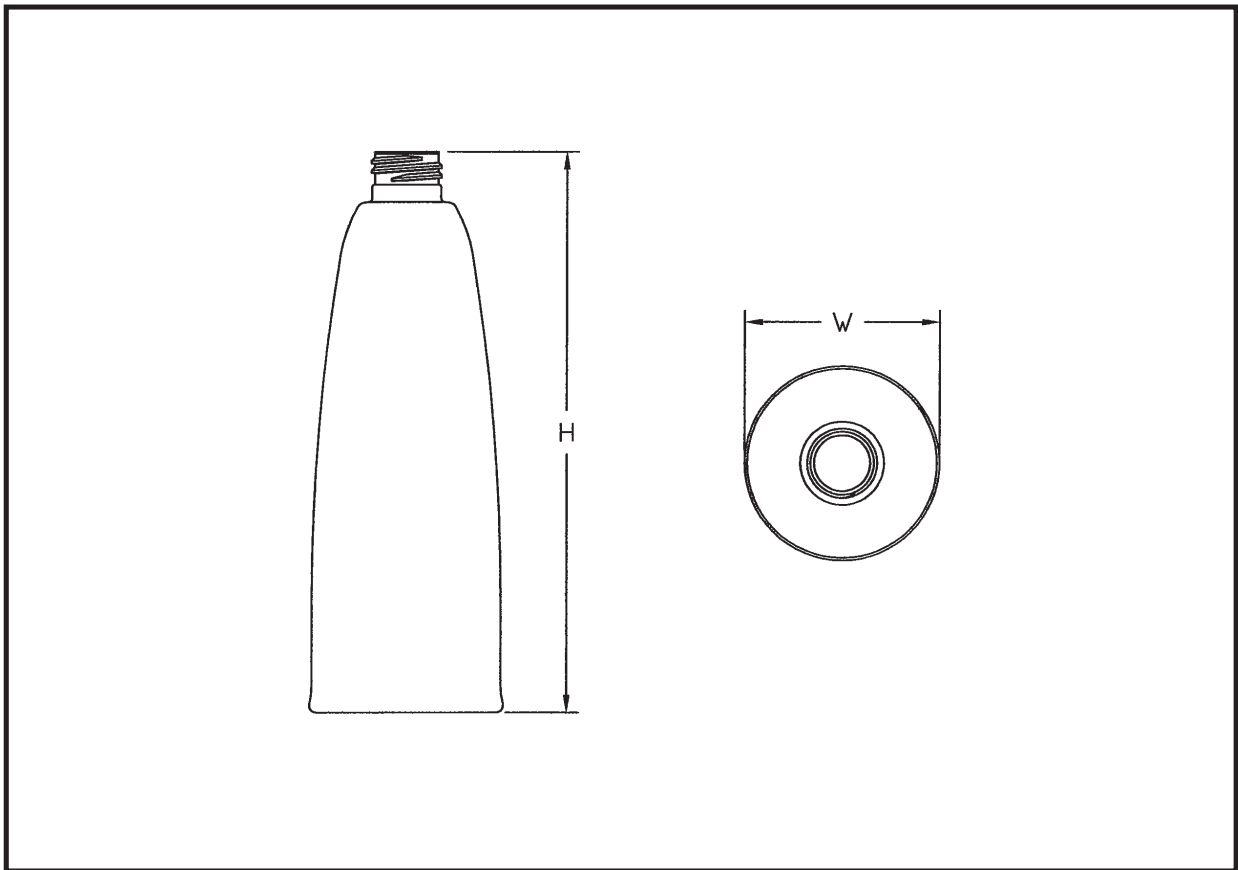

CAPITOL ROUNDS

CAPACITY	NECKS	MATERIAL	HEIGHT	DIAMETER
15 oz	24-410	OPET	7.75"	2.60"
15 oz	24-415	OPET	8.061"	2.60"

PHILLY ROUNDS

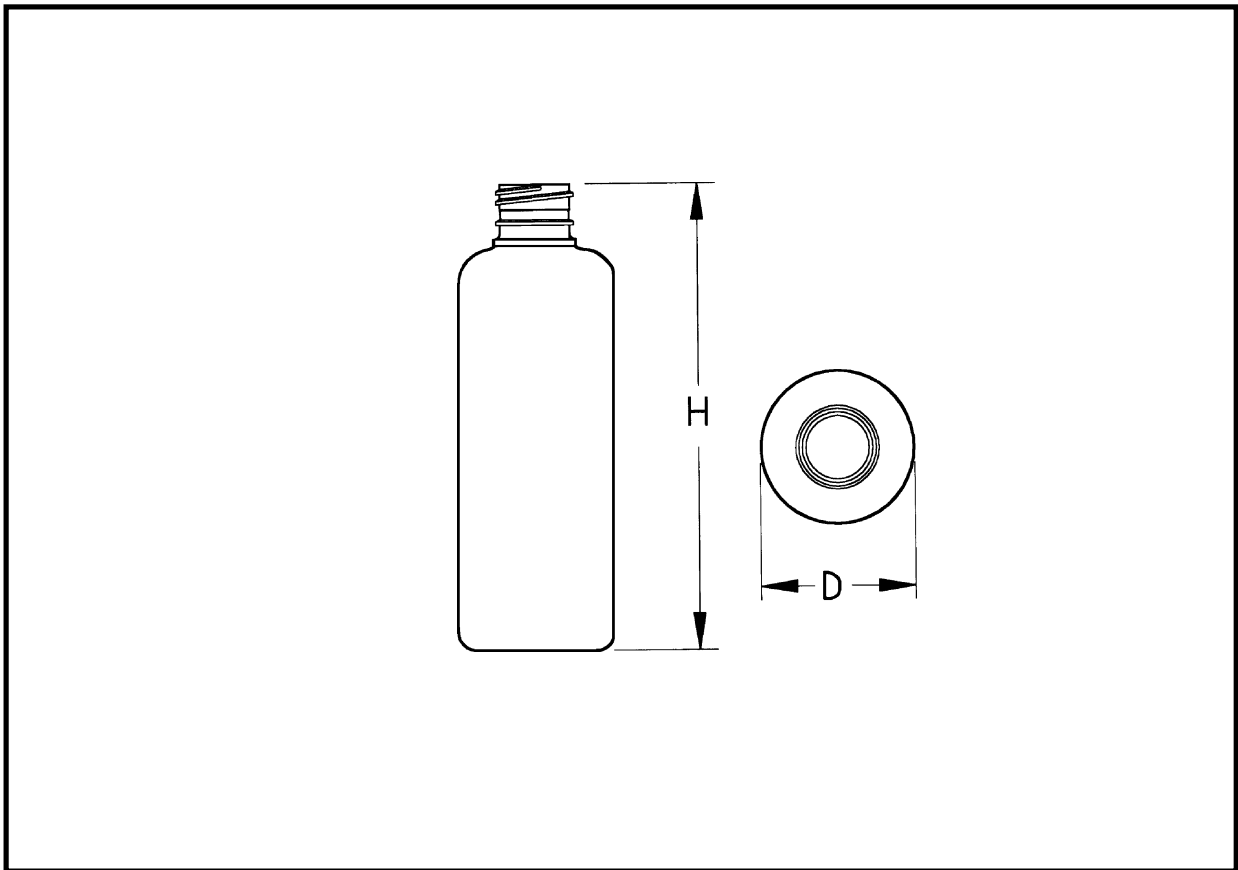

PHILLY ROUNDS

CAPACITY	NECKS	MATERIAL	HEIGHT	DIAMETER
2 / 2.46 oz	20-415	PVC	3.95"	1.42"
4 / 4.70 oz	24-415	PVC	5.51"	1.64"

Secondary capacity measurement represents cosmetic fill point to base of neck.
 For a 50,000 piece order, we could look at building an OPET version.

PHILLY ROUNDS

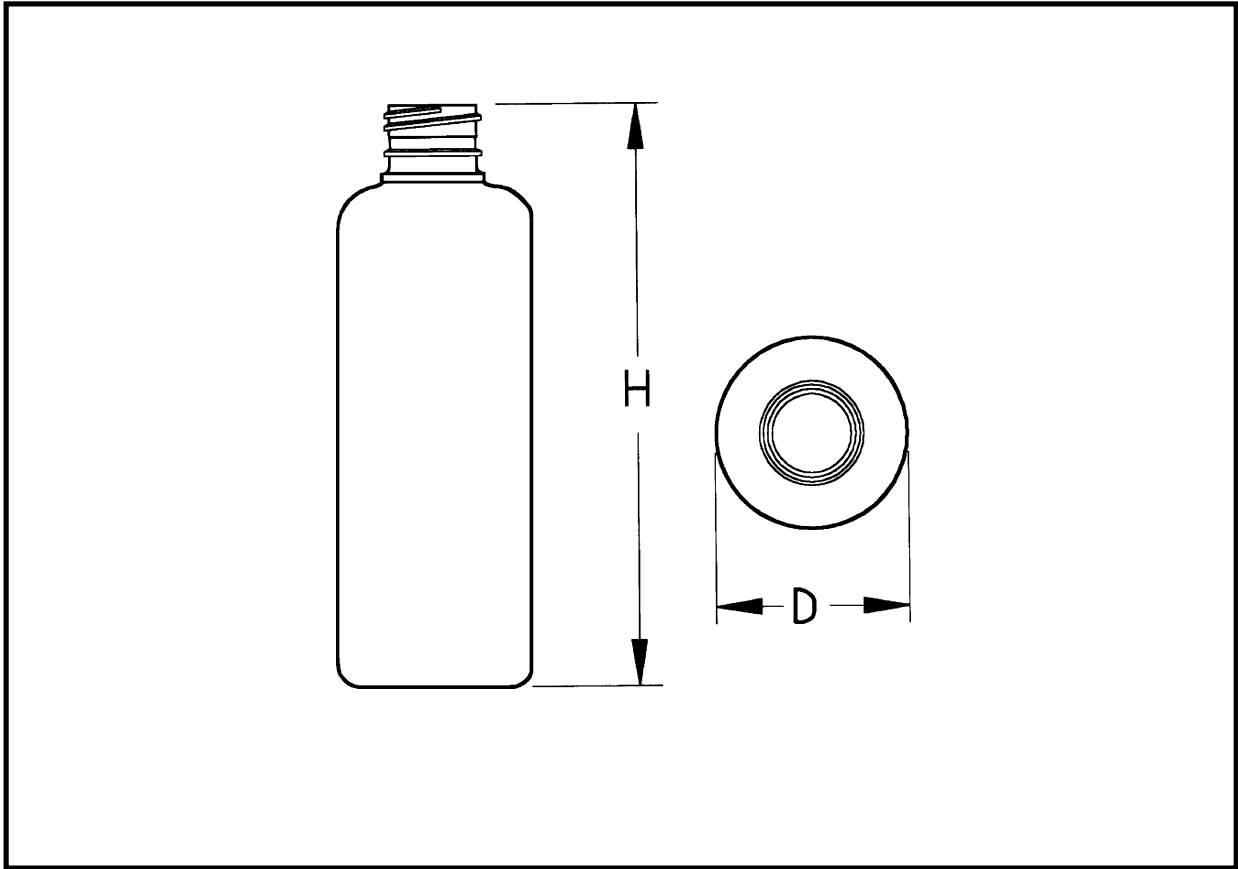

PHILLY ROUNDS

CAPACITY	NECKS	MATERIAL	HEIGHT	DIAMETER
6 /6.79 oz	24-410	HDPE, LDPE	5.65"	1.87"
6 /6.79 oz	24-415	HDPE, LDPE	5.95"	1.87"
8 /8.71 oz	24-410	PVC or OPET	6.29"	1.99"
8 /8.71 oz	24-415	PVC or OPET	6.60"	1.99"
8 /8.71 oz*	24-400 Special	PVC	6.576"	1.99"
8 oz*	28-400	PVC	6.03"	1.99"
12 oz*	28-400	PVC	7.30"	2.135"

Secondary capacity measurement represents cosmetic fill point to base of neck.

*For a 50,000 piece order, we could look at building an OPET version.

LAB FLASK

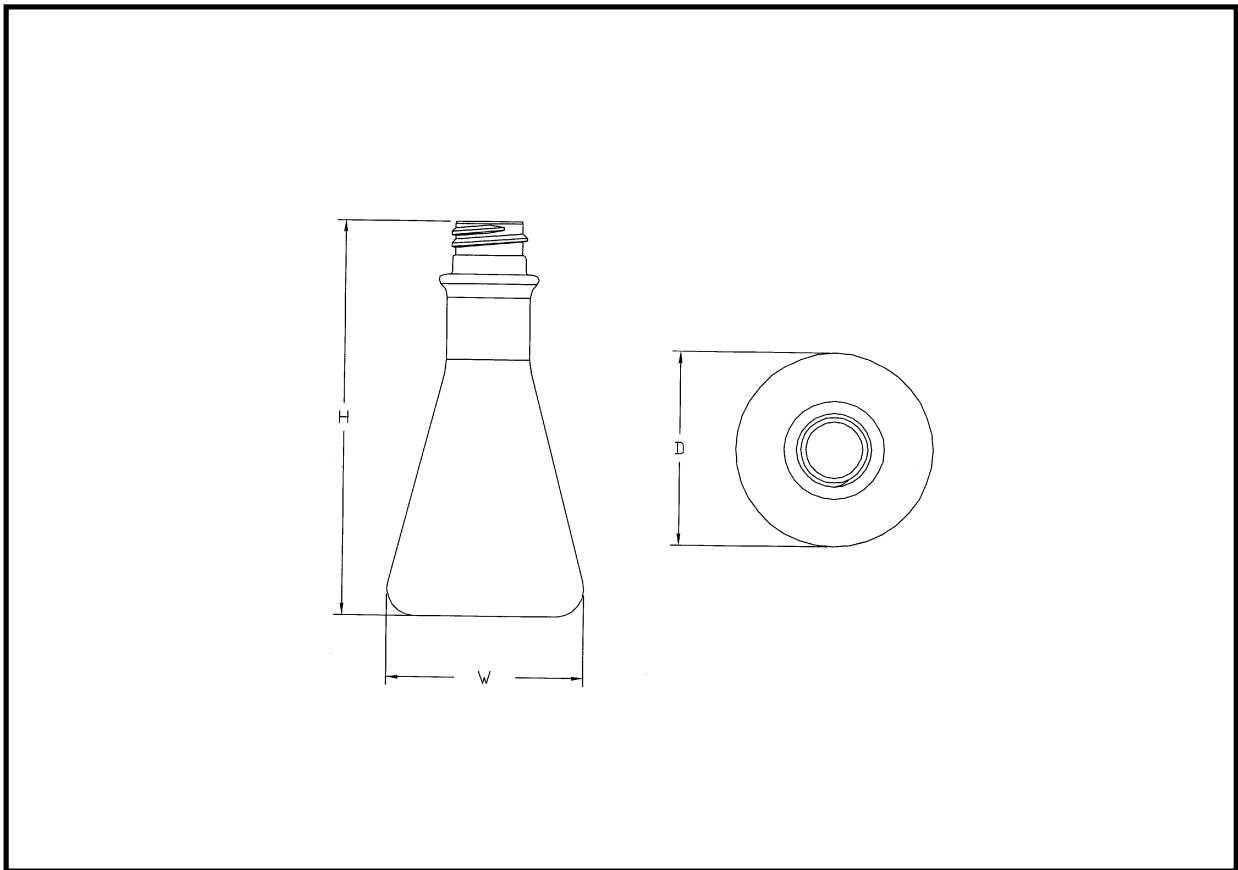

LAB FLASK

CAPACITY	NECKS	MATERIAL	HEIGHT	DIAMETER
2.5 oz	20-410	HDPE or MDPE	4.131"	2.035"

LAB FLASKS

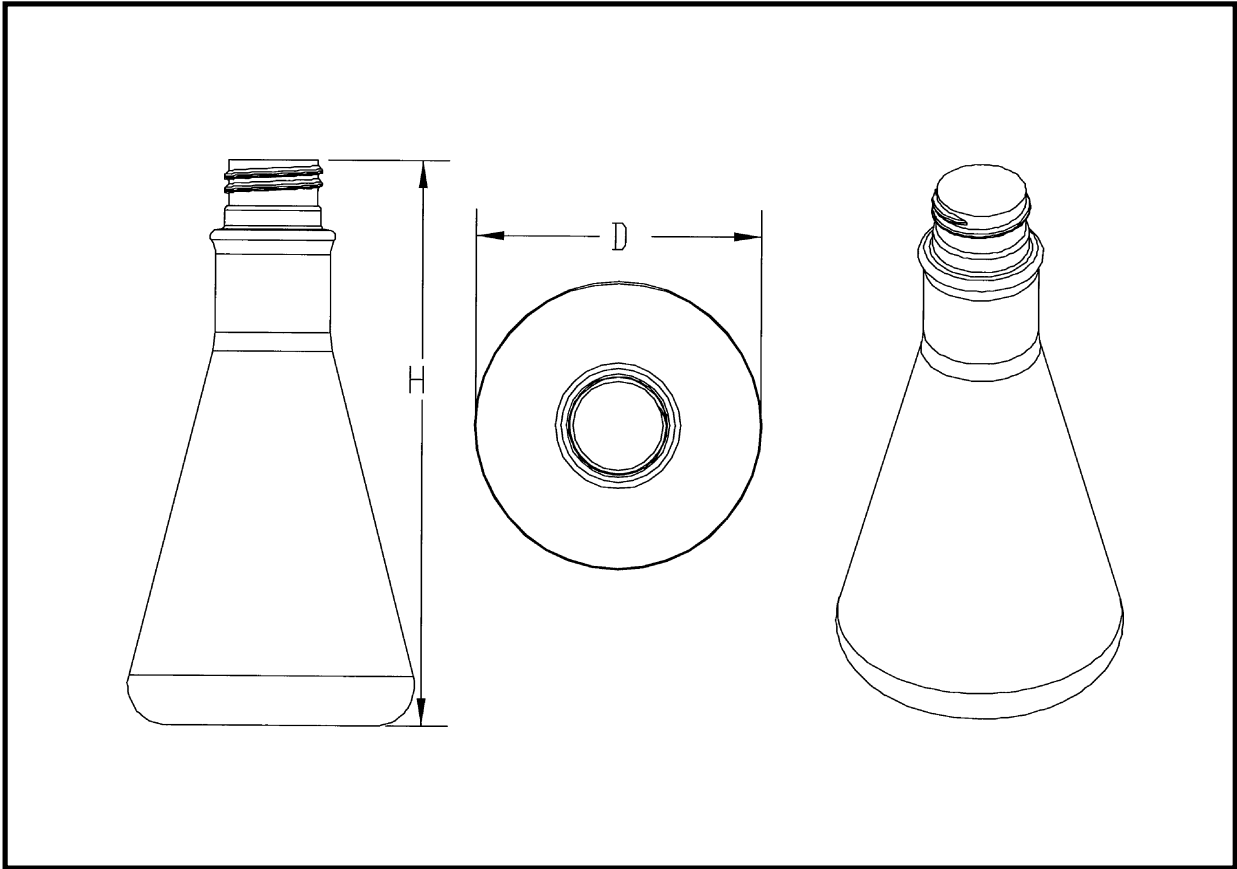

LAB FLASKS

CAPACITY	NECKS	MATERIAL	HEIGHT	DIAMETER
6 oz	22-400	OPET	5.37"	2.725"
6 oz	24-410	OPET	5.35"	2.725"
12 oz	22-400 .470" H	OPET	6.38"	3.43"
12 oz	28-410	OPET	6.44"	3.43"

BELL ROUND

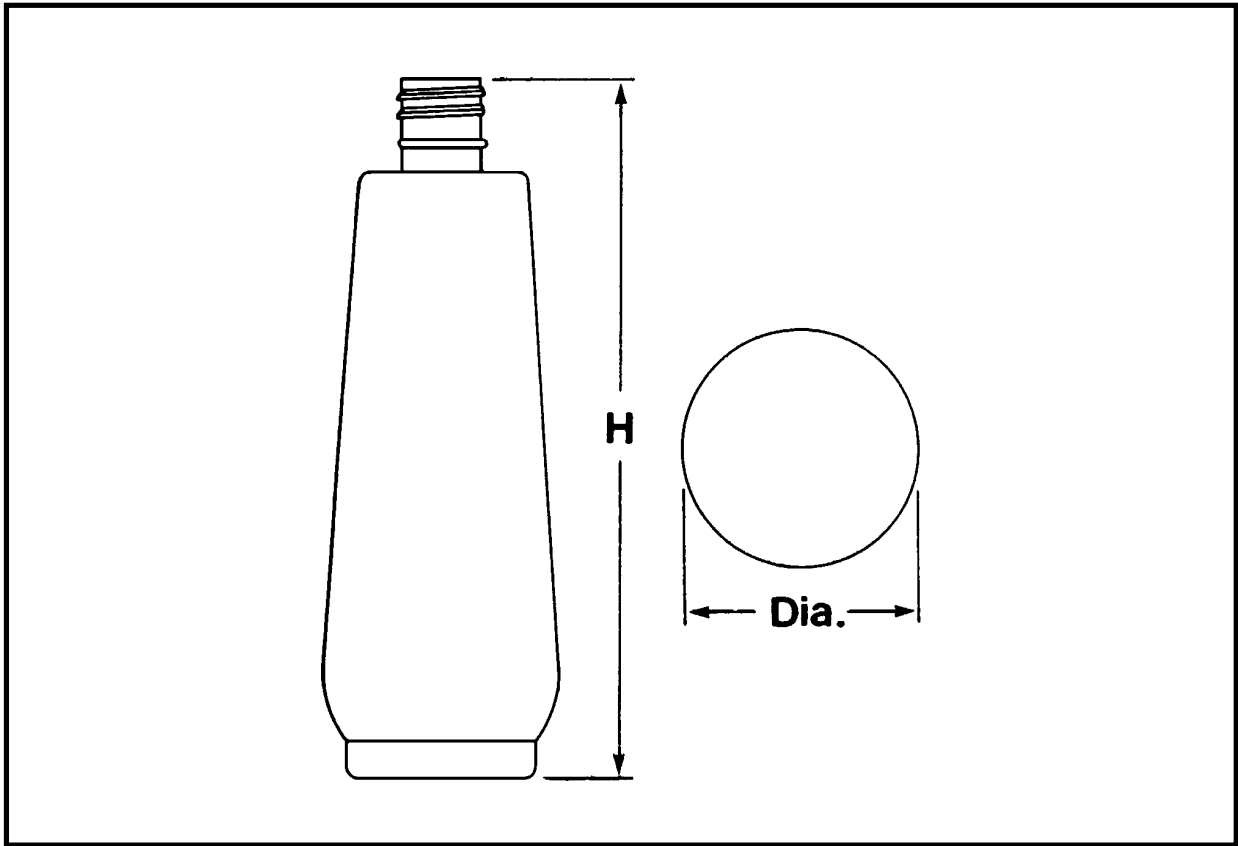

BELL ROUND

CAPACITY	NECKS	MATERIAL	HEIGHT	DIAMETER
12 /12.11 oz	24-415	PVC	7.00"	2.49"

Secondary capacity measurement represents cosmetic fill point to base of neck.
 For a 50,000 piece order, we could look at building an OPET version.

BELLA ROUNDS

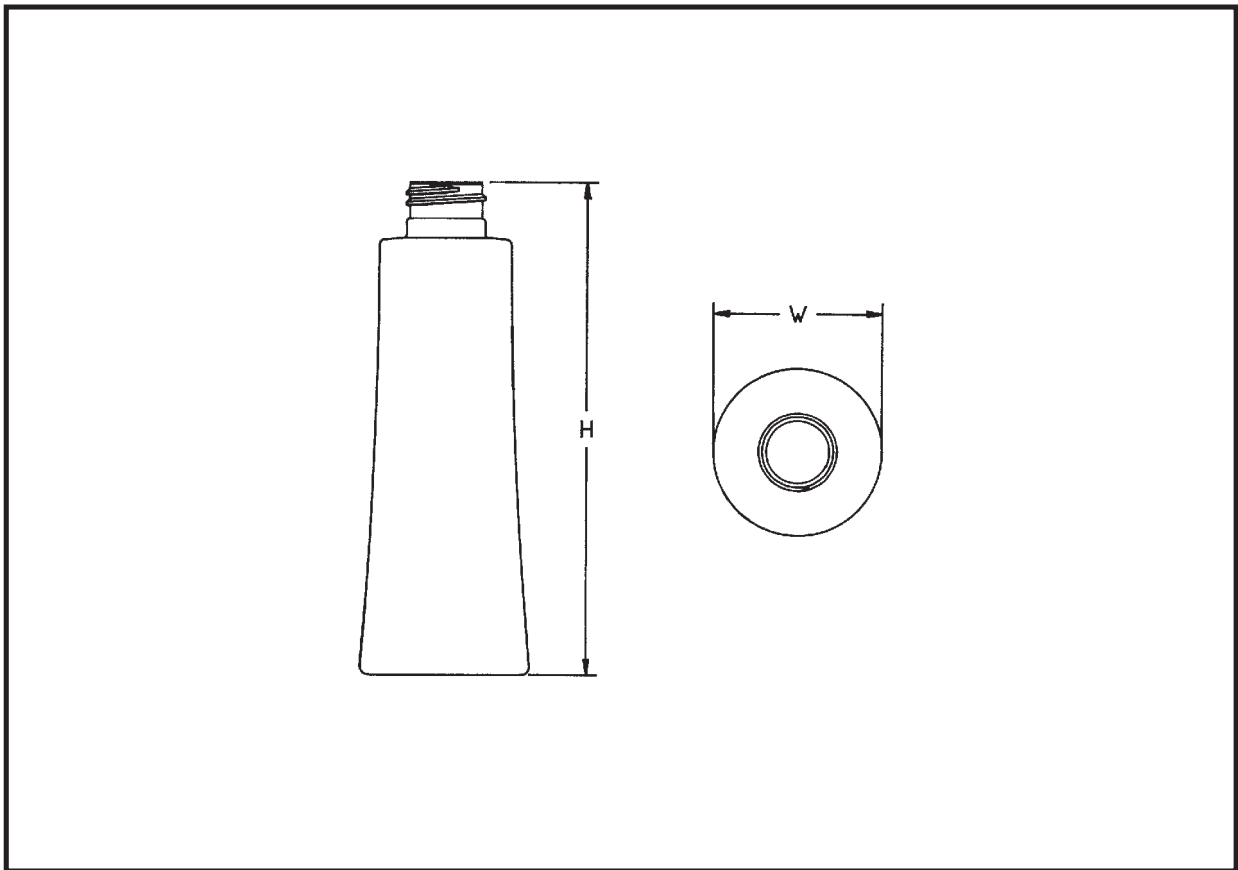

BELLA ROUNDS

CAPACITY	NECKS	MATERIAL	HEIGHT	DIAMETER
2 oz	20-410	HDPE	4.1"	1.45"
6 oz	24-410	HDPE	5.893"	2.00"
6 oz	24-415	HDPE	6.204"	2.00"

BELLA ROUND

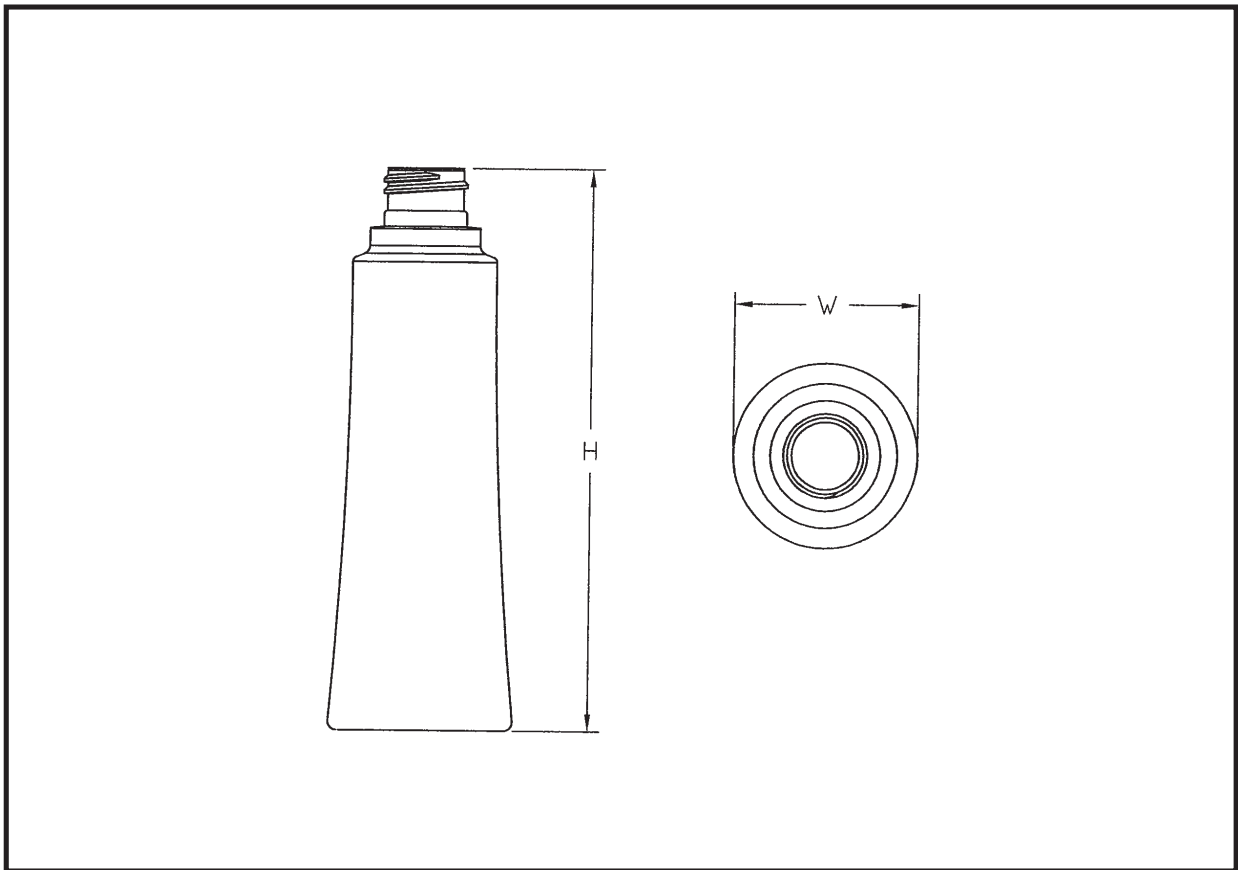

BELLA ROUND

CAPACITY	NECKS	MATERIAL	HEIGHT	DIAMETER
6 oz	24mm Jazz	HDPE	5.893"	2.056"

24mm Jazz Sprayer is available through SeaquistPerfect

SCULPTED ROUND

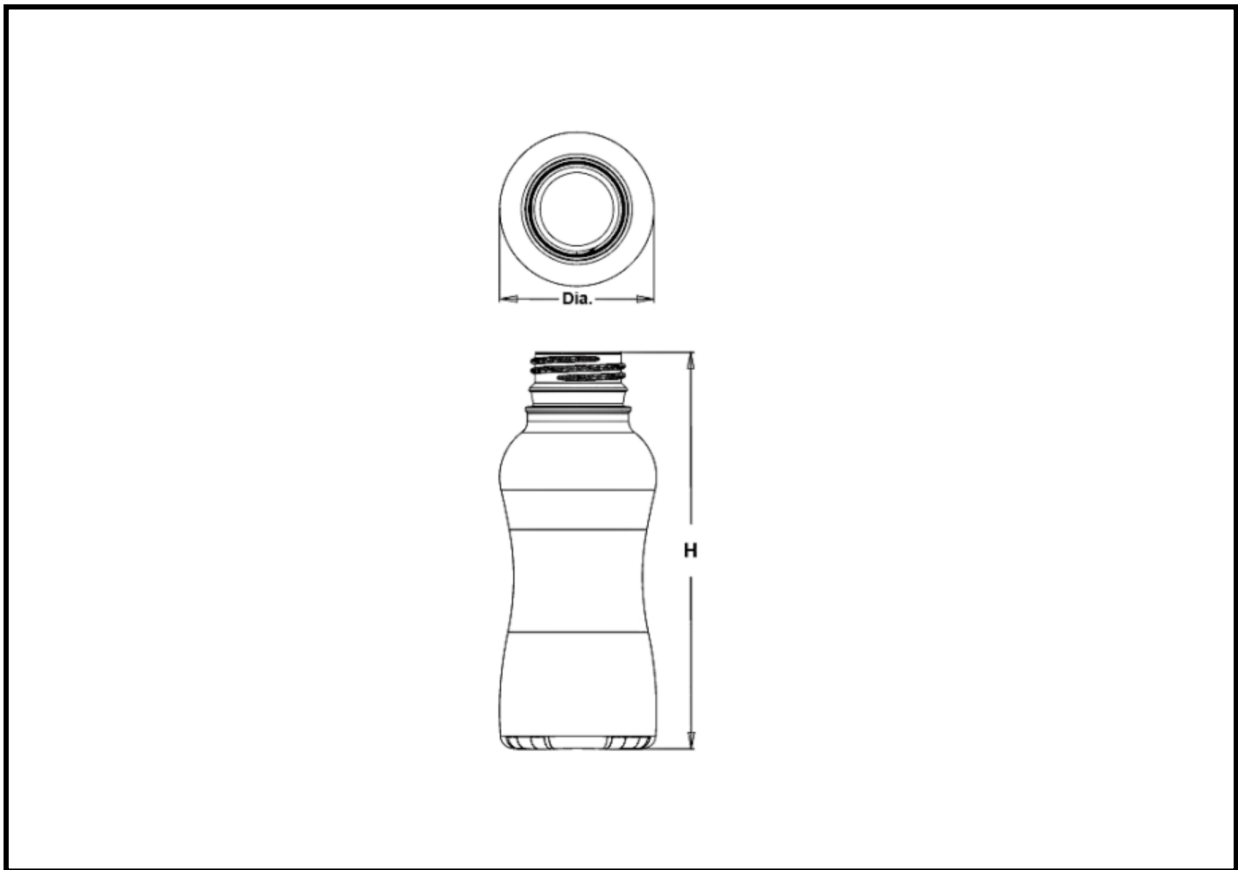

SCULPTED ROUND

CAPACITY	NECKS	MATERIAL	HEIGHT	DIAMETER
6 oz	33mm Drop-Lok	HDPE	5.29"	2.085"

CELEBRITY ROUND

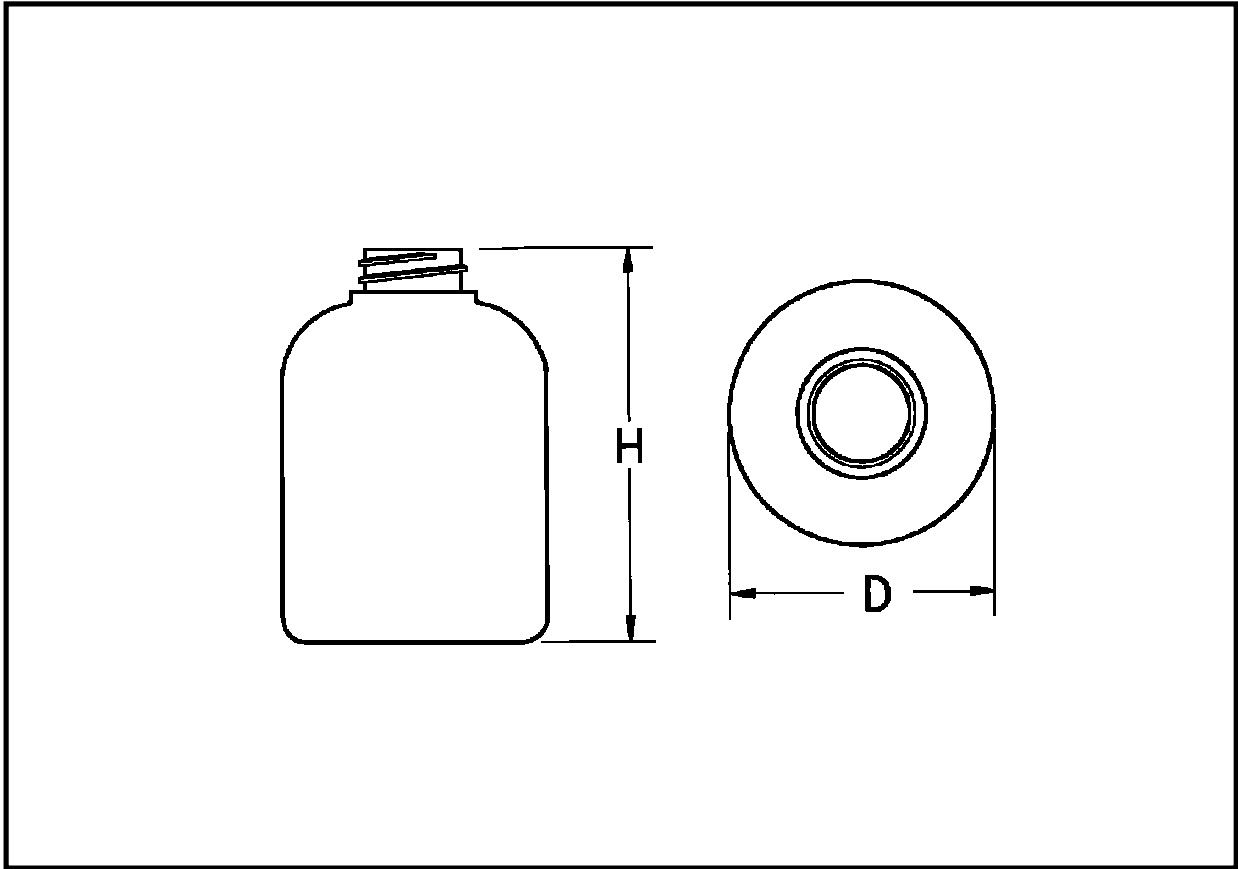

CELEBRITY ROUND

CAPACITY	NECKS	MATERIAL	HEIGHT	DIAMETER
8 / 9.26 oz	28-400	HDPE	4.01"	2.68"
8 / 9.26 oz	28-410	HDPE	4.32"	2.68"

Secondary capacity measurement represents cosmetic fill point to base of neck.
 Available with or without view stripe.

SMOOTH BUTTRESS BOSTON ROUND

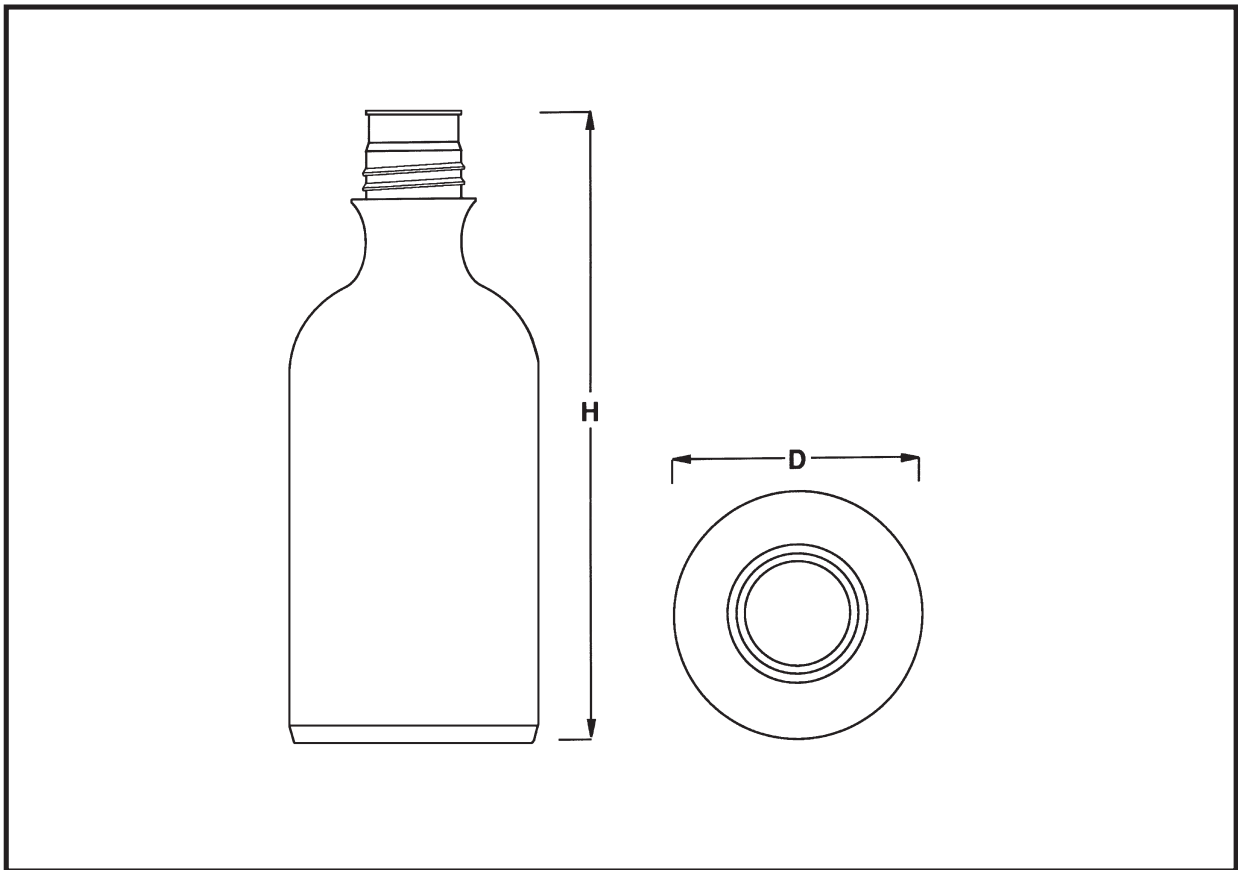

SMOOTH BUTTRESS BOSTON ROUND

CAPACITY	NECKS	MATERIAL	HEIGHT	DIAMETER
32 oz	38-430	HDPE	9.03"	3.54"

38-430V closures available through Plastic Bottle Corporation

BOSTON ROUND BUTTRESS

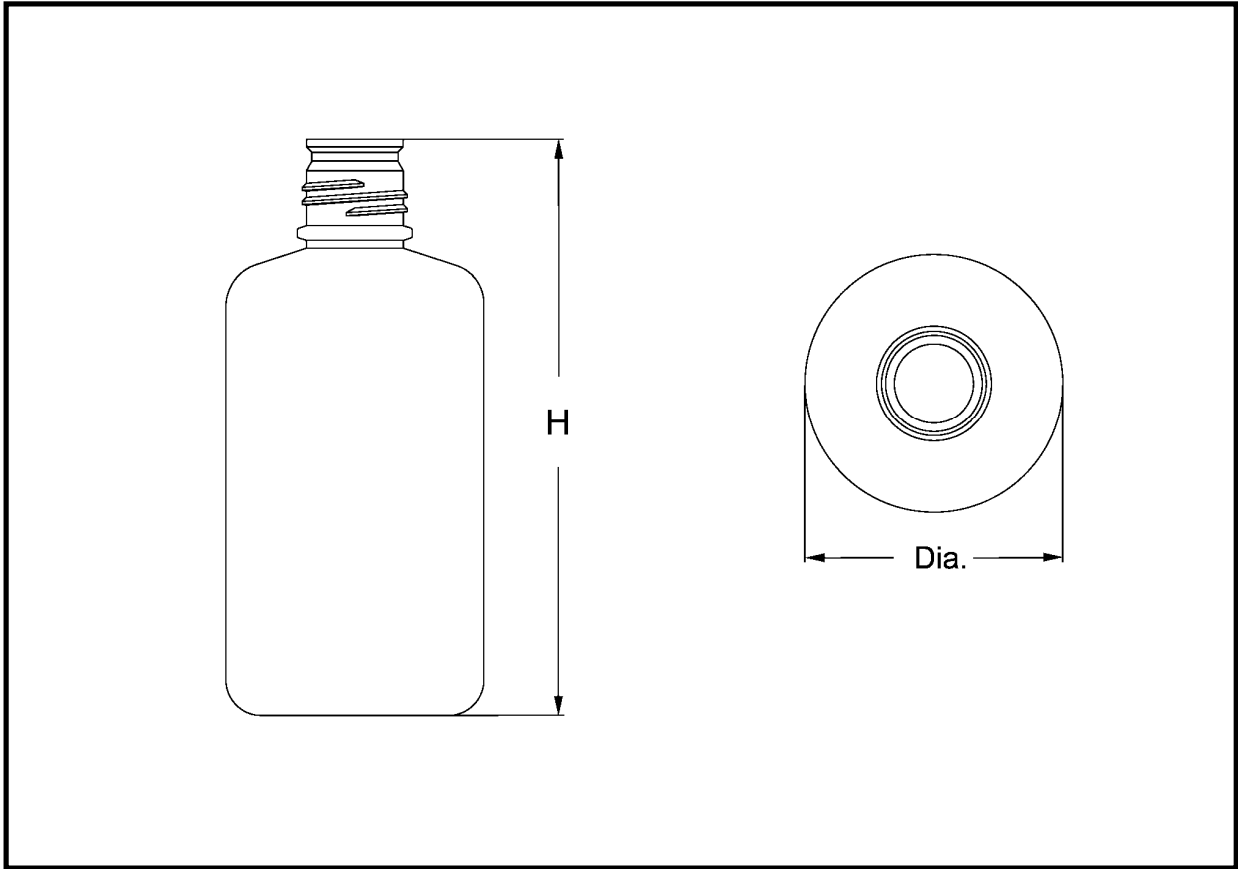

BOSTON ROUND BUTTRESS

CAPACITY	NECKS	MATERIAL	HEIGHT	DIAMETER
32 oz / 1 Liter	38-430	HDPE	8.175"	3.665"

TK ROUNDS

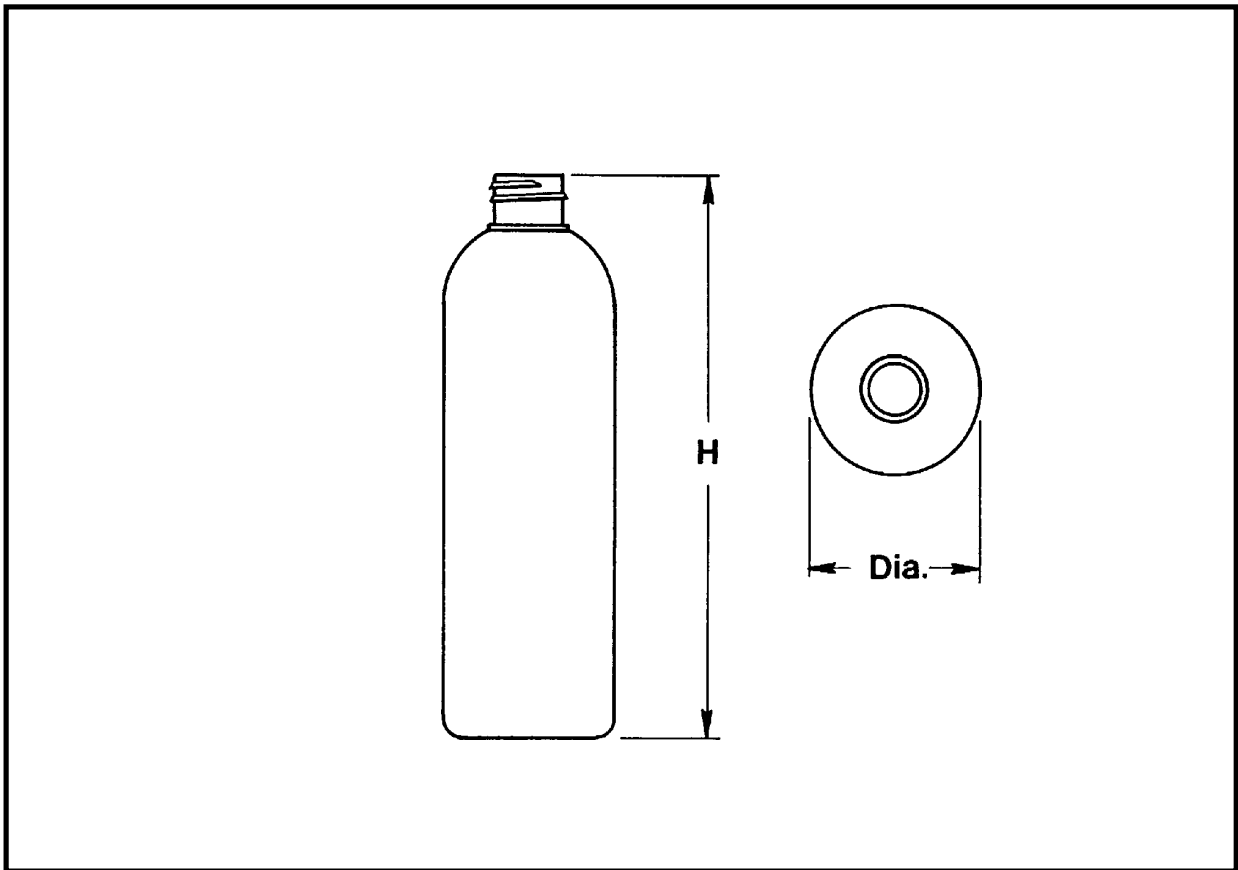

TK ROUNDS

CAPACITY	NECKS	MATERIAL	HEIGHT	DIAMETER
2 oz	20-410	HDPE	3.80"	1.40"
2 oz	22-415	HDPE	4.00"	1.40"
4 oz	24-410	HDPE or LDPE	4.76"	1.75"
8 oz	20-410	HDPE	6.481"	1.94"
8 oz	22-415	HDPE	6.98"	1.94"
8 oz	24-410	HDPE	6.80"	1.94"
12 oz	24-410	HDPE	7.54"	2.206"
16 oz	24-415	HDPE	8.05"	2.44"

Available with and without view striping.

TK ROUNDS

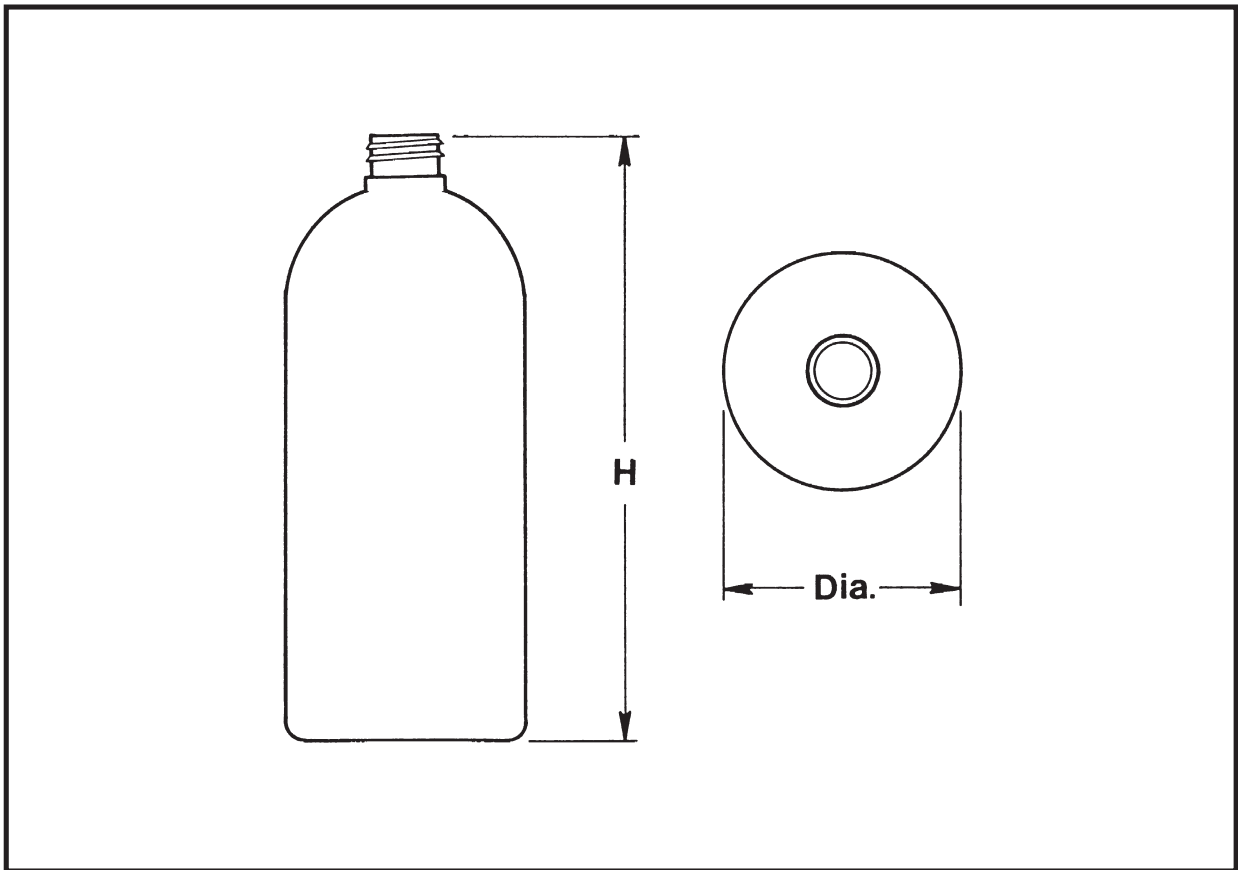

TK ROUNDS

CAPACITY	NECKS	MATERIAL	HEIGHT	DIAMETER
32 oz/1 liter	28-410	HDPE	8.74"	3.41"

#709 ADDITIVE ROUNDS

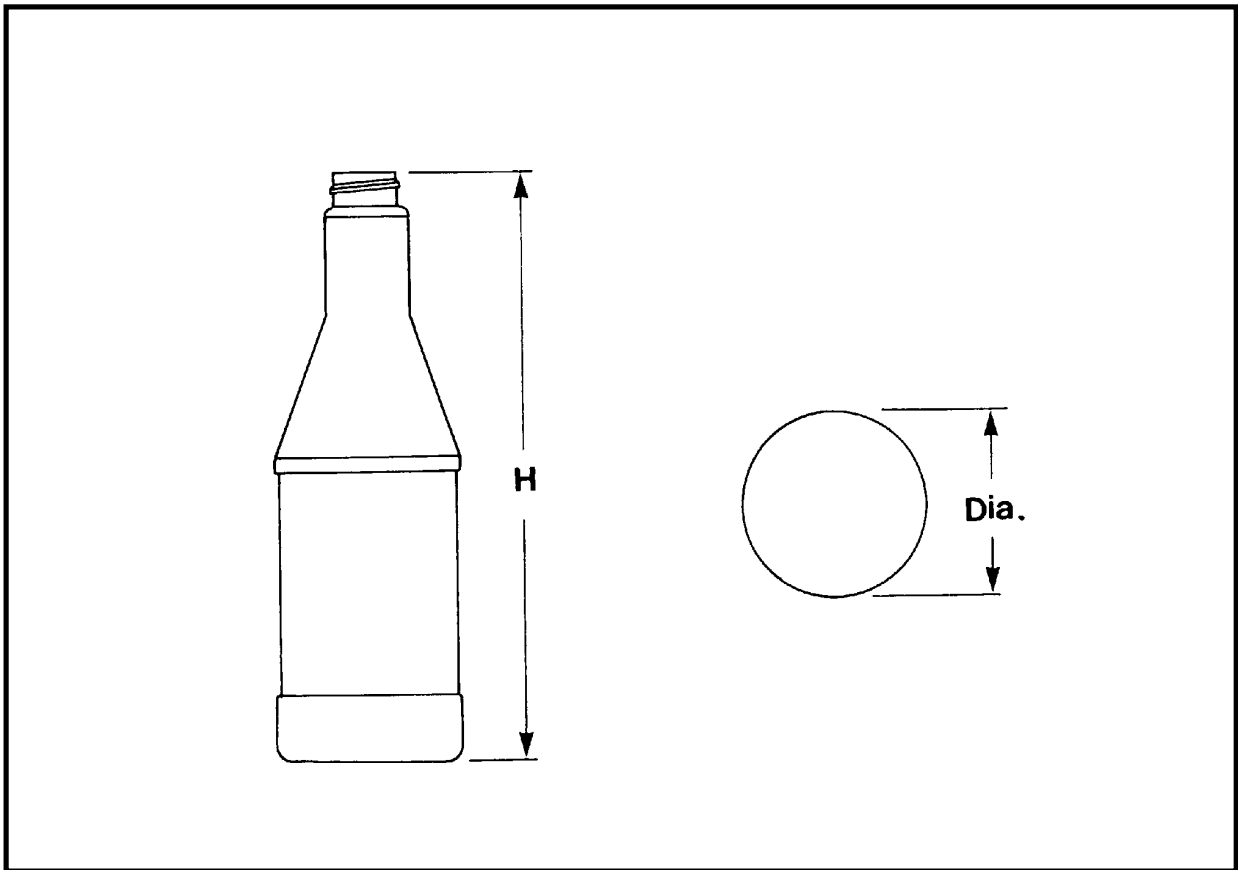

#709 ADDITIVE ROUNDS

CAPACITY	NECKS	MATERIAL	HEIGHT	DIAMETER
6 oz	22-400 .417H	PVC	6.403"	1.865"
6 oz	22-400 .484H	PVC	6.47"	1.865"
6 oz	22-414	PVC	6.533"	1.865"
12 oz	24-400	PVC	7.79"	2.52"

#709 ADDITIVE ROUNDS

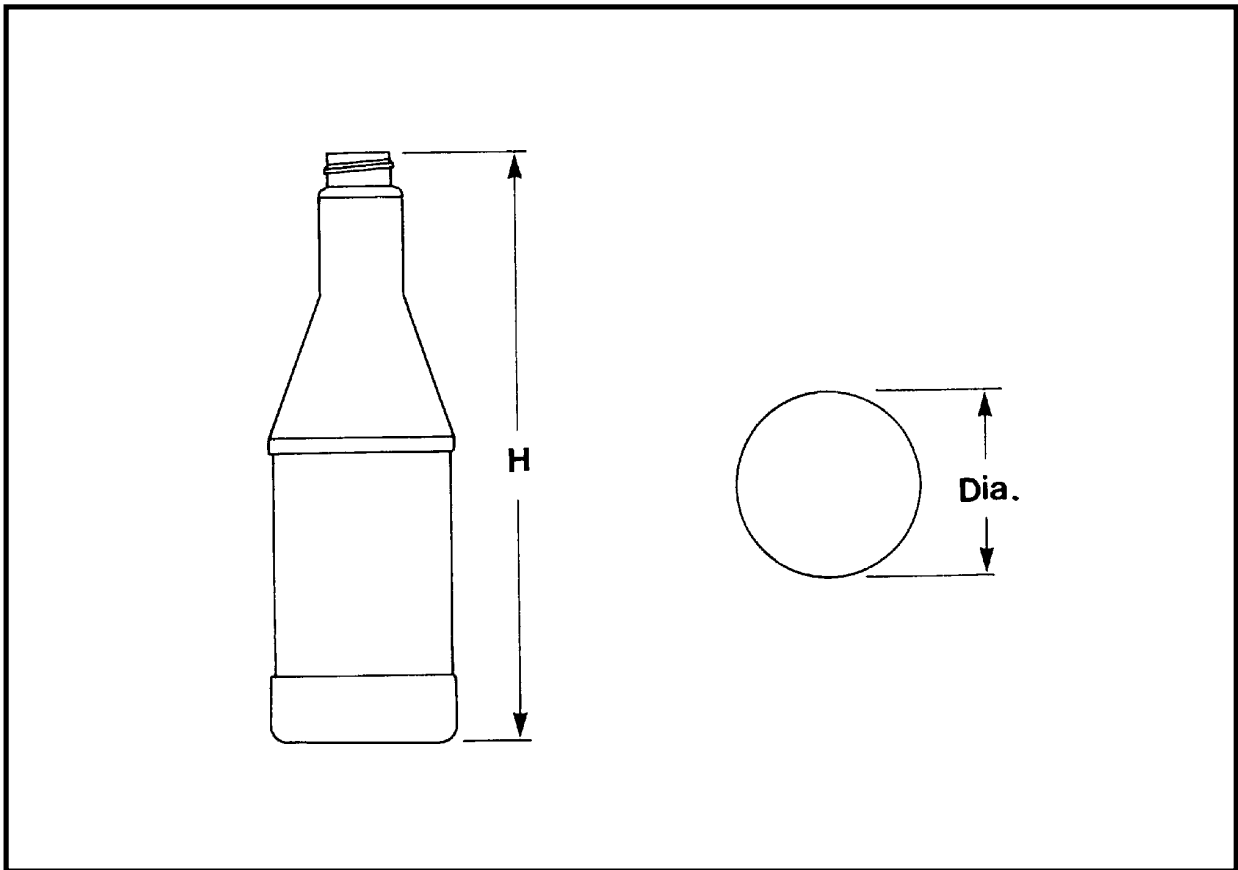

#709 ADDITIVE ROUNDS

CAPACITY	NECKS	MATERIAL	HEIGHT	DIAMETER
12 oz	20-400	HDPE	7.71"	2.46"
12 oz	21mm Snap	HDPE	7.71"	2.46"
12 oz	24-400	HDPE	7.631"	2.46"

AUSTIN ROUND

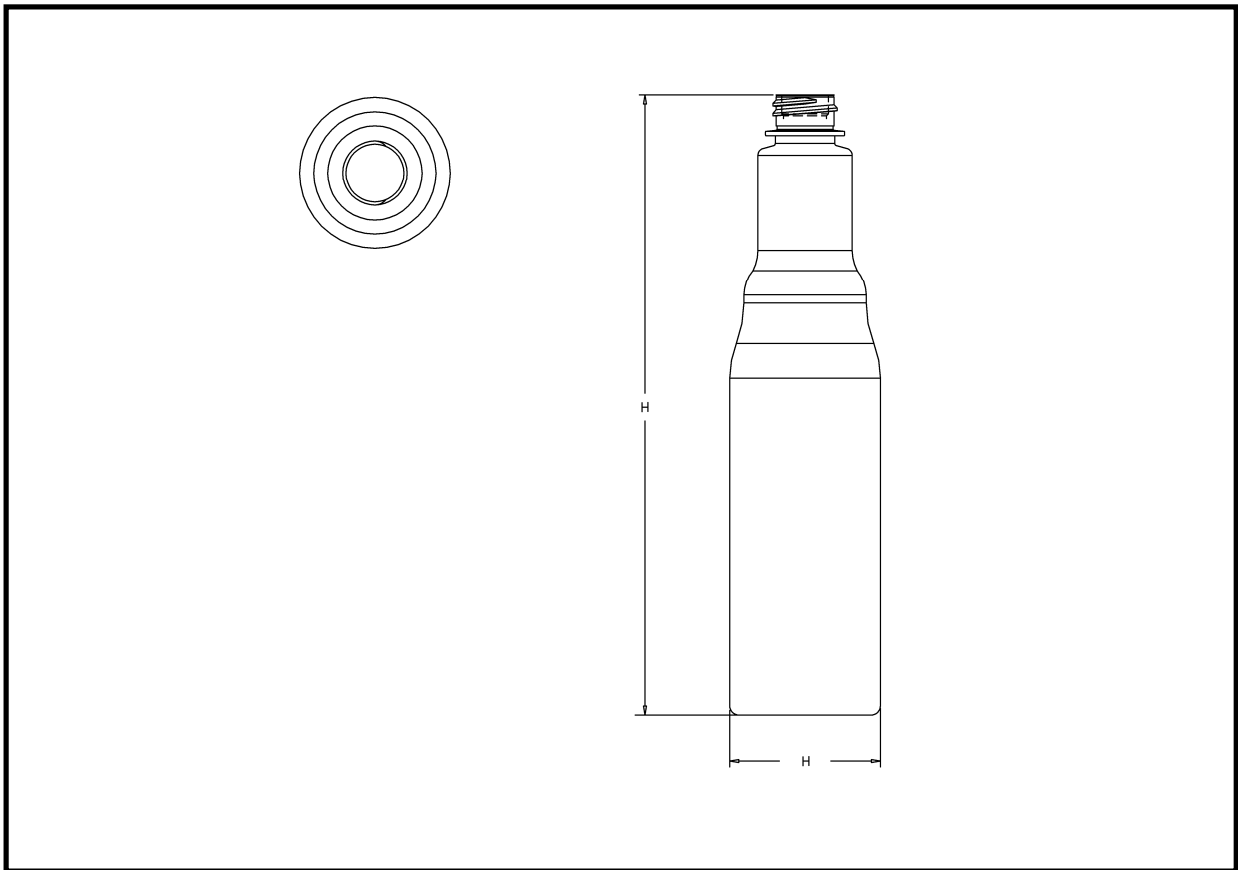

AUSTIN ROUND

CAPACITY	NECKS	MATERIAL	HEIGHT	DIAMETER
8 oz / 250 ml	22-400 .471" H	OPET	8.246"	2.00"

AUSTIN ROUND CAPLESS COMPATIBLE

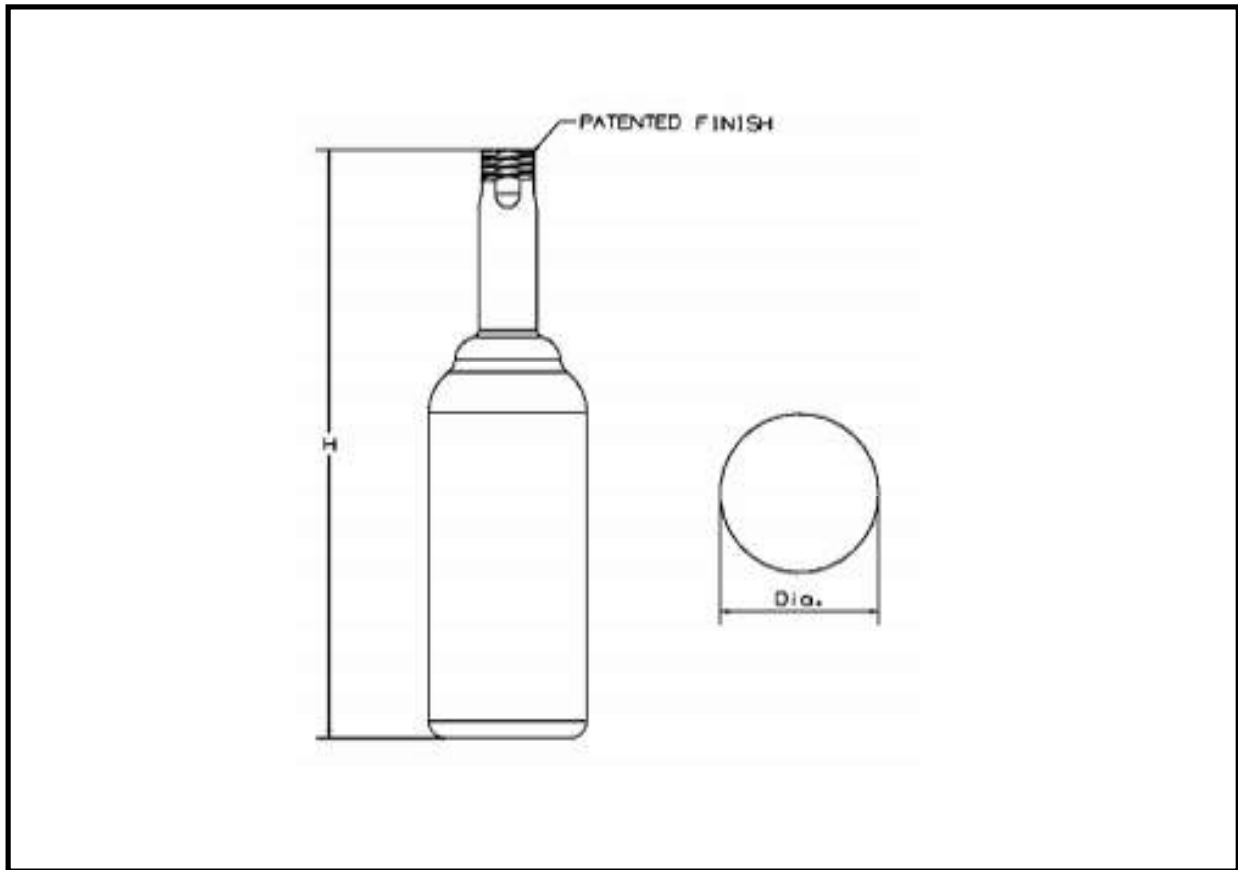

AUSTIN ROUND CAPLESS COMPATIBLE

CAPACITY	NECKS	MATERIAL	HEIGHT	DIAMETER
6 oz	22mm Special*	OPET	8.375"	1.65"
8 oz	22mm Special*	OPET	8.375"	1.90"
12 oz	22mm Special*	OPET and PVC	8.678"	2.34"

*22mm Special Capless Compatible Neck Finish, Neck Patent Number 9,878,989

AUSTIN ROUND

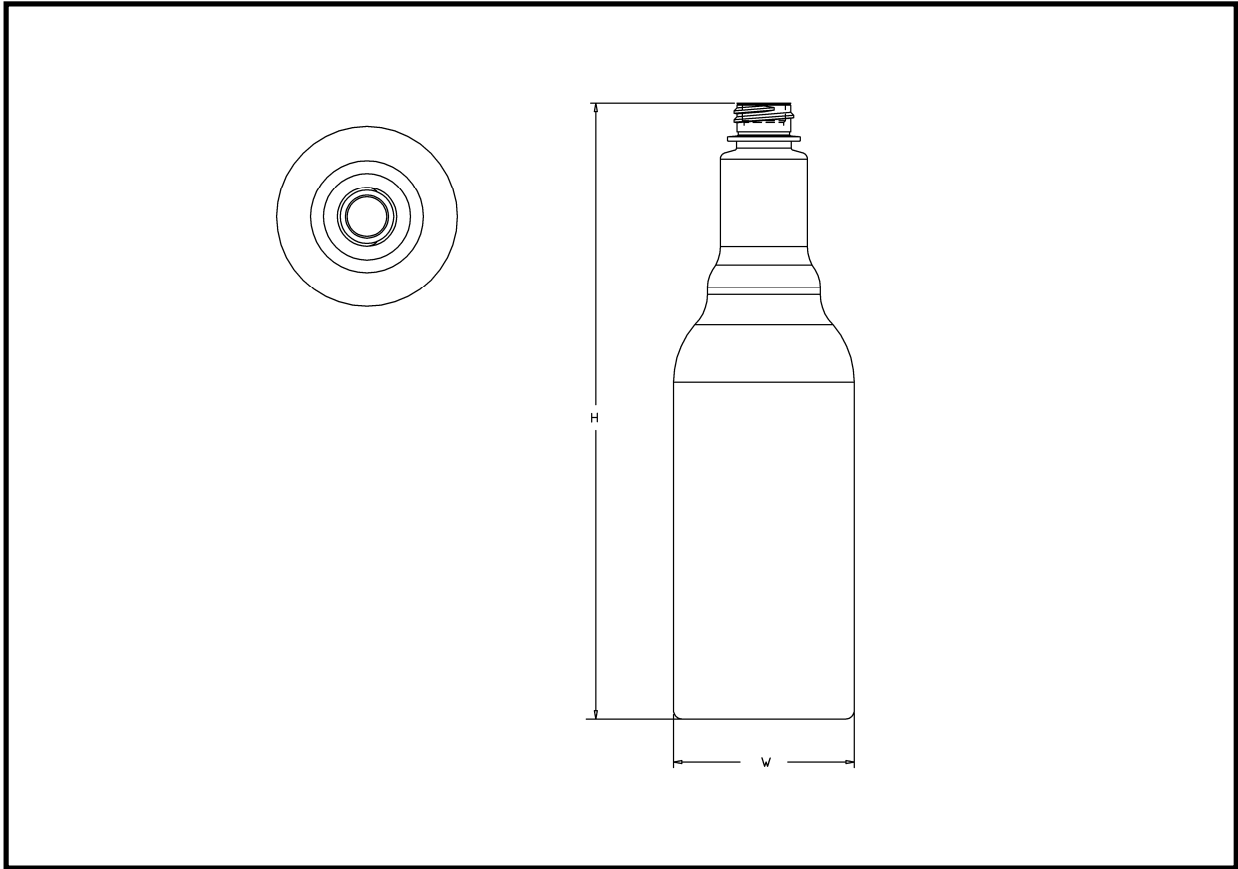

AUSTIN ROUND

CAPACITY	NECKS	MATERIAL	HEIGHT	DIAMETER
16 oz / 500 ml	22-400 .471" H	OPET	8.875"	2.60"

AUSTIN ROUND

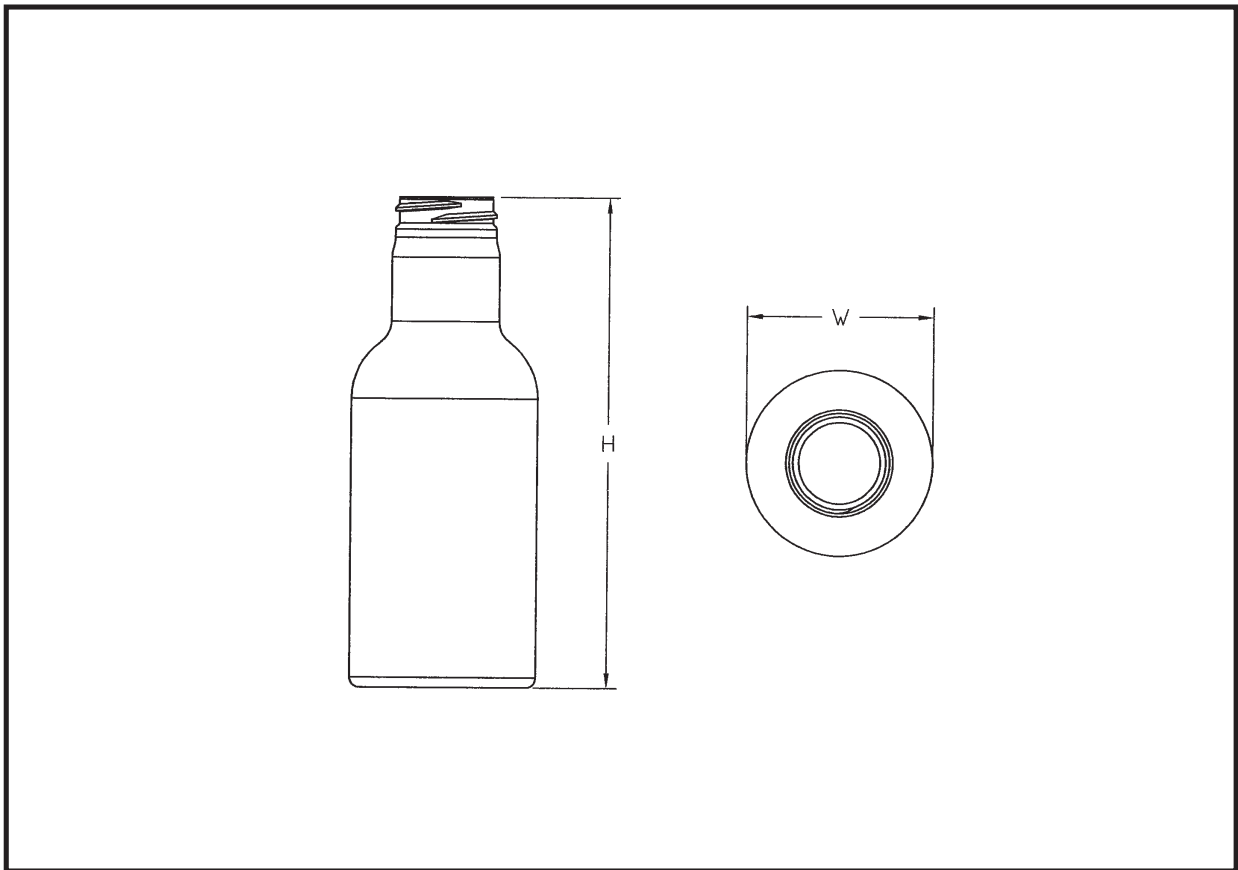

AUSTIN ROUND

CAPACITY	NECKS	MATERIAL	HEIGHT	DIAMETER
8 oz	33-400	PVC or PETG	6.115"	2.32"

AUSTIN ROUNDS

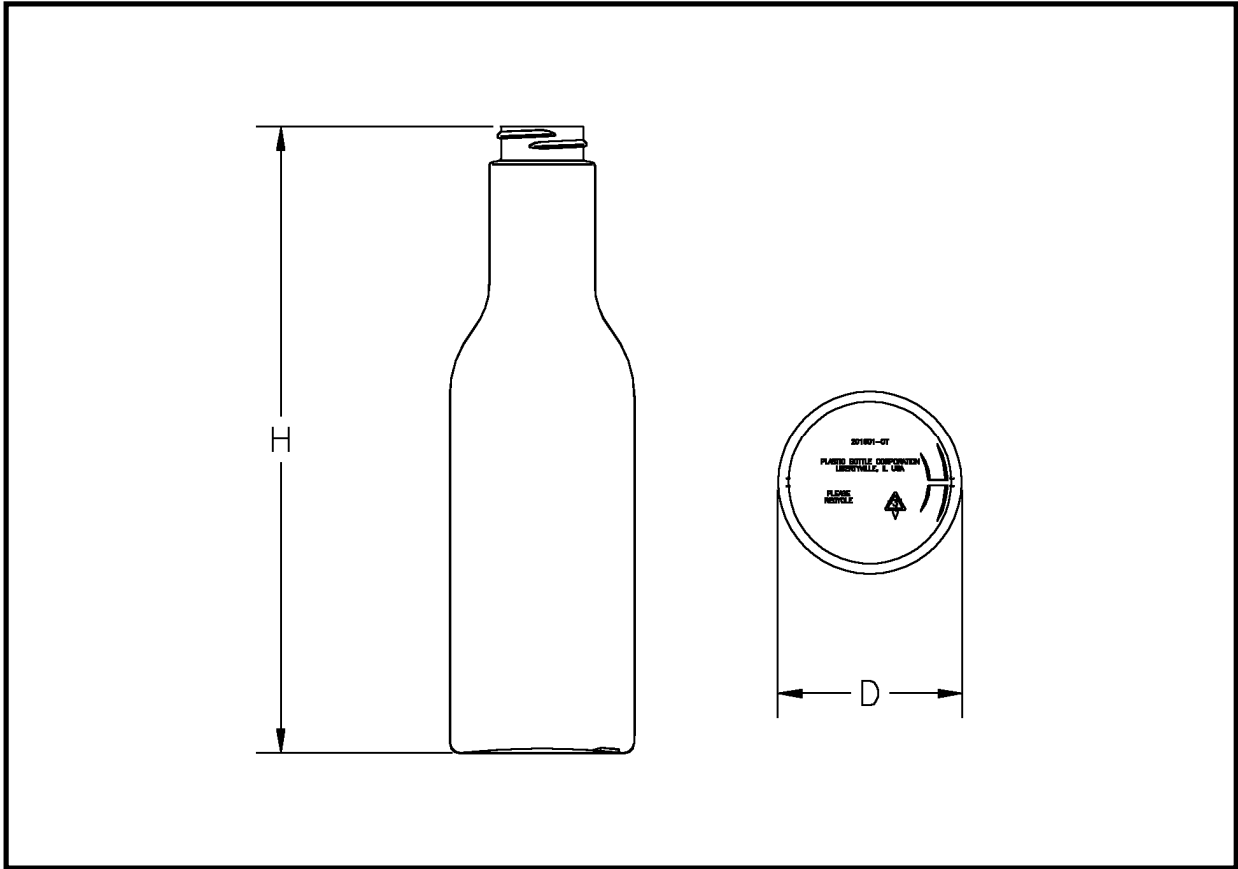

AUSTIN ROUNDS

CAPACITY	NECKS	MATERIAL	HEIGHT	DIAMETER
16 oz / 500 ml	33-400	PVC	8.85"	2.60"

AUSTIN ROUNDS

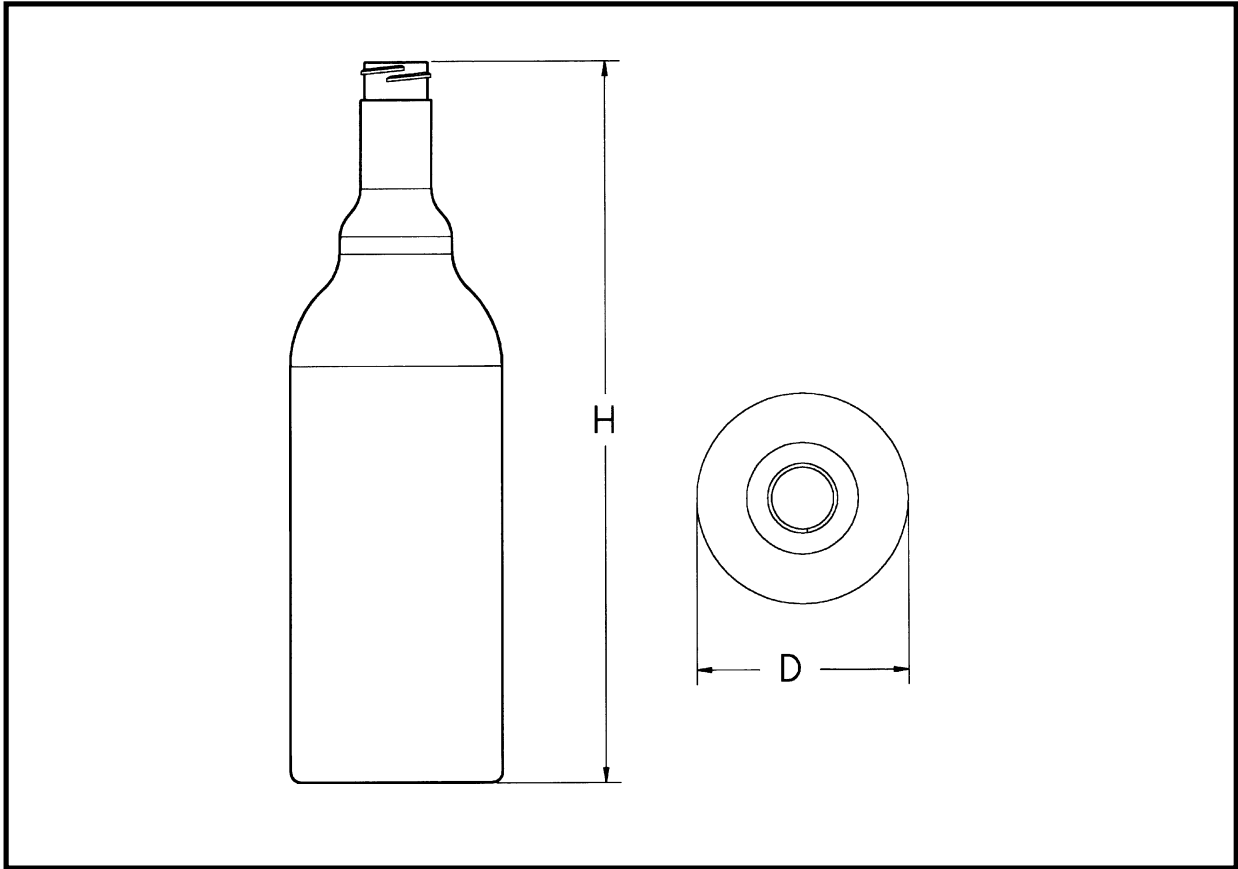

AUSTIN ROUNDS

CAPACITY	NECKS	MATERIAL	HEIGHT	DIAMETER
8 oz	22-400	PVC or PETG	6.75"	2.32"
12 oz	21mm Snap	PVC	7.35"	2.60"
12 oz	22-400*	PVC	7.49"	2.60"
16 oz	20-400 .460" H	PVC	8.908"	2.60"
16 oz	21mm Snap	PVC	8.75"	2.60"
16 oz	22-400*	PVC	8.89"	2.60"

* Available with either .371" or .450" H dimensions

AUSTIN ROUNDS

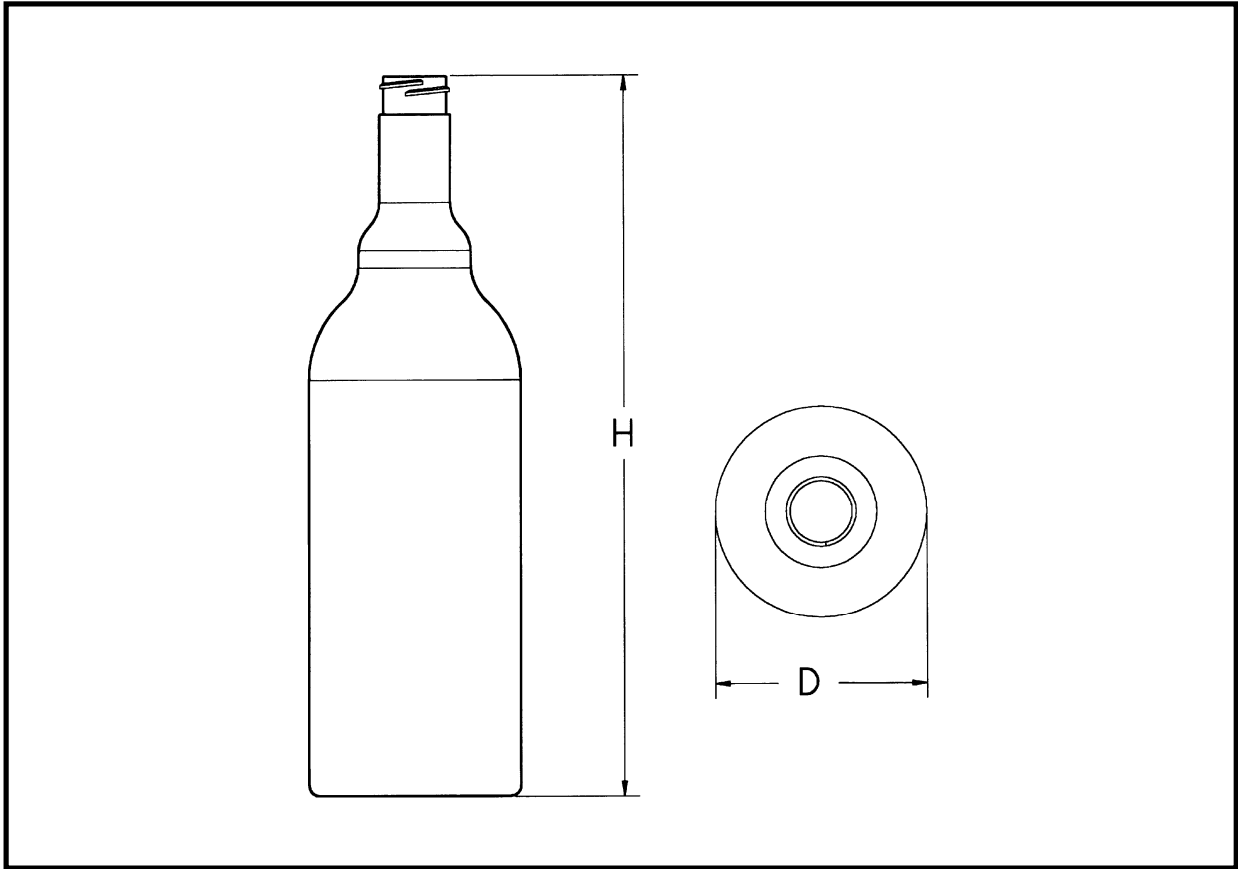

AUSTIN ROUNDS

CAPACITY	NECKS	MATERIAL	HEIGHT	DIAMETER
8 oz	22-400	HDPE	6.75"	2.32"
12 oz	20mm SPCC*	HDPE	7.50"	2.60"
12 oz	22mm SPCC*	HDPE	7.50"	2.60"
12 oz	22-400 .450" H	HDPE	7.50"	2.60"

Available with or without view stripe

*SPCC: These necks work with regular screw and child resistant closures. Samples are available for customer testing with currently available capless compatible fuel filler systems.

Where great ideas take shape.

AUSTIN ROUNDS

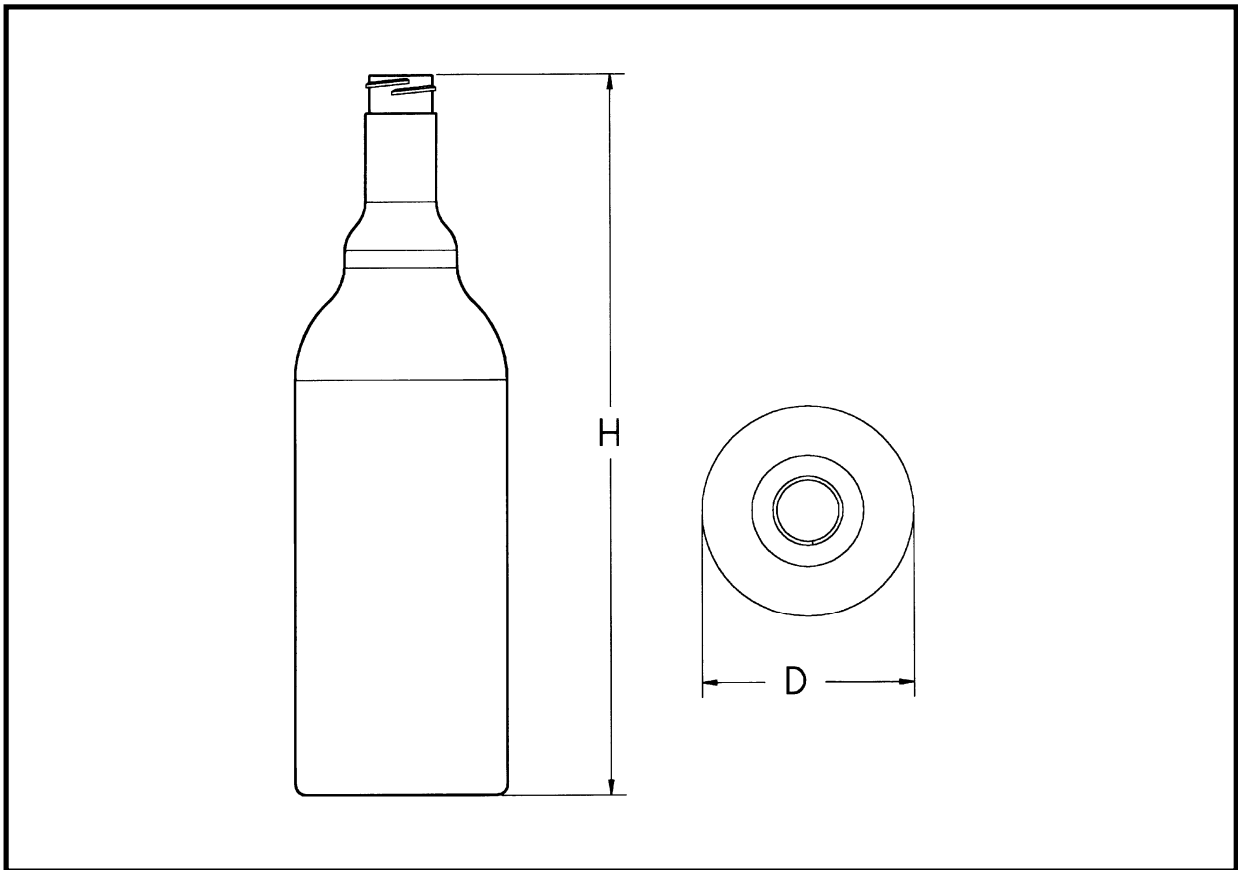

AUSTIN ROUNDS

CAPACITY	NECKS	MATERIAL	HEIGHT	DIAMETER
16 oz	20mm SPCC*	HDPE	8.875"	2.60"
16 oz	22mm SPCC*	HDPE	8.875"	2.60"
16 oz	22-400	HDPE	8.81"	2.60"

Available with or without view stripe

*SPCC: These necks work with regular screw and child resistant closures. Samples are available for customer testing with currently available capless compatible fuel filler systems.

AUSTIN ROUND/LONG NECK

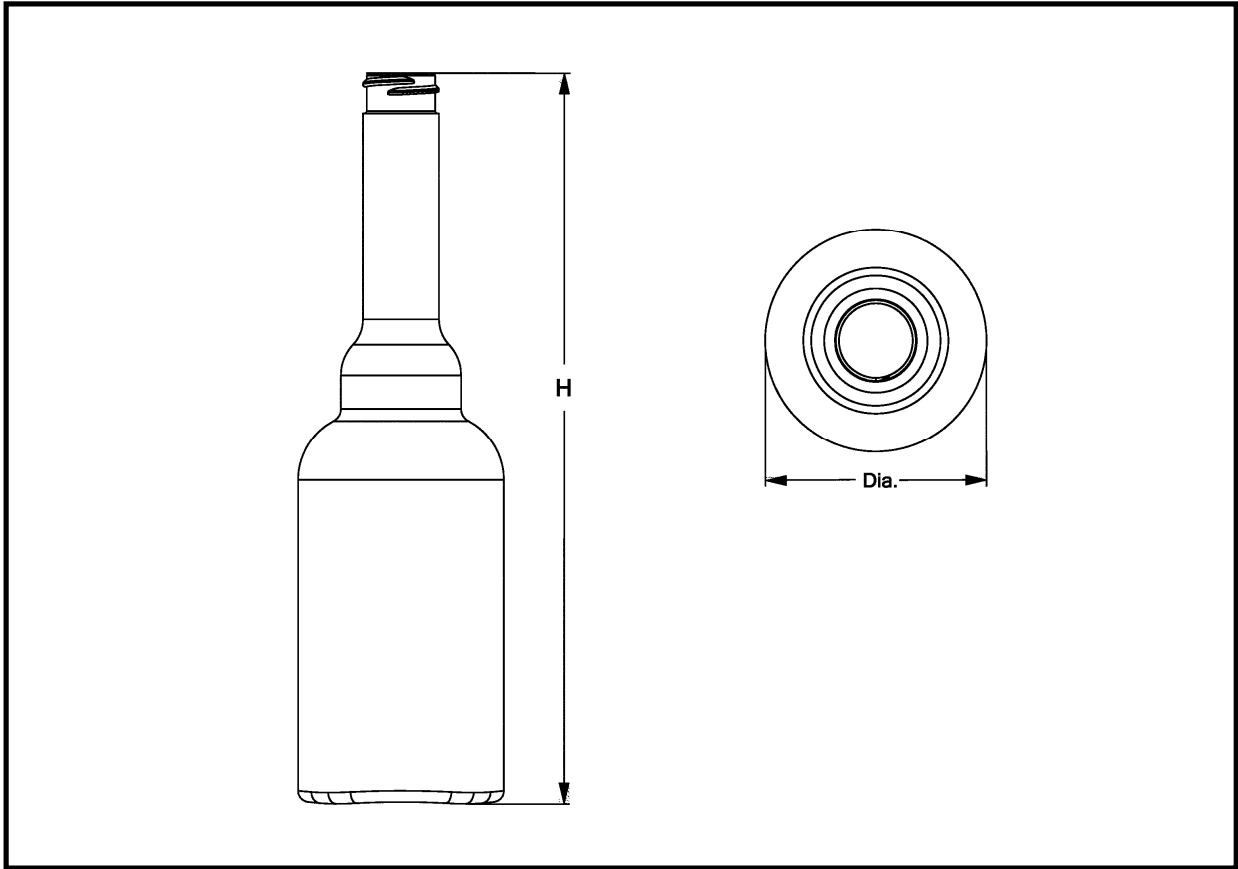

AUSTIN ROUND/LONG NECK

CAPACITY	NECKS	MATERIAL	HEIGHT	DIAMETER
8 oz	22-400	HDPE	8.175"	2.311"
8 oz	22mm SPCC*	HDPE	8.175"	2.311"

*SPCC: This neck works with regular screw and child resistant closures. Samples are available for customer testing with currently available capless compatible fuel filler systems.

ROMAN ROUND

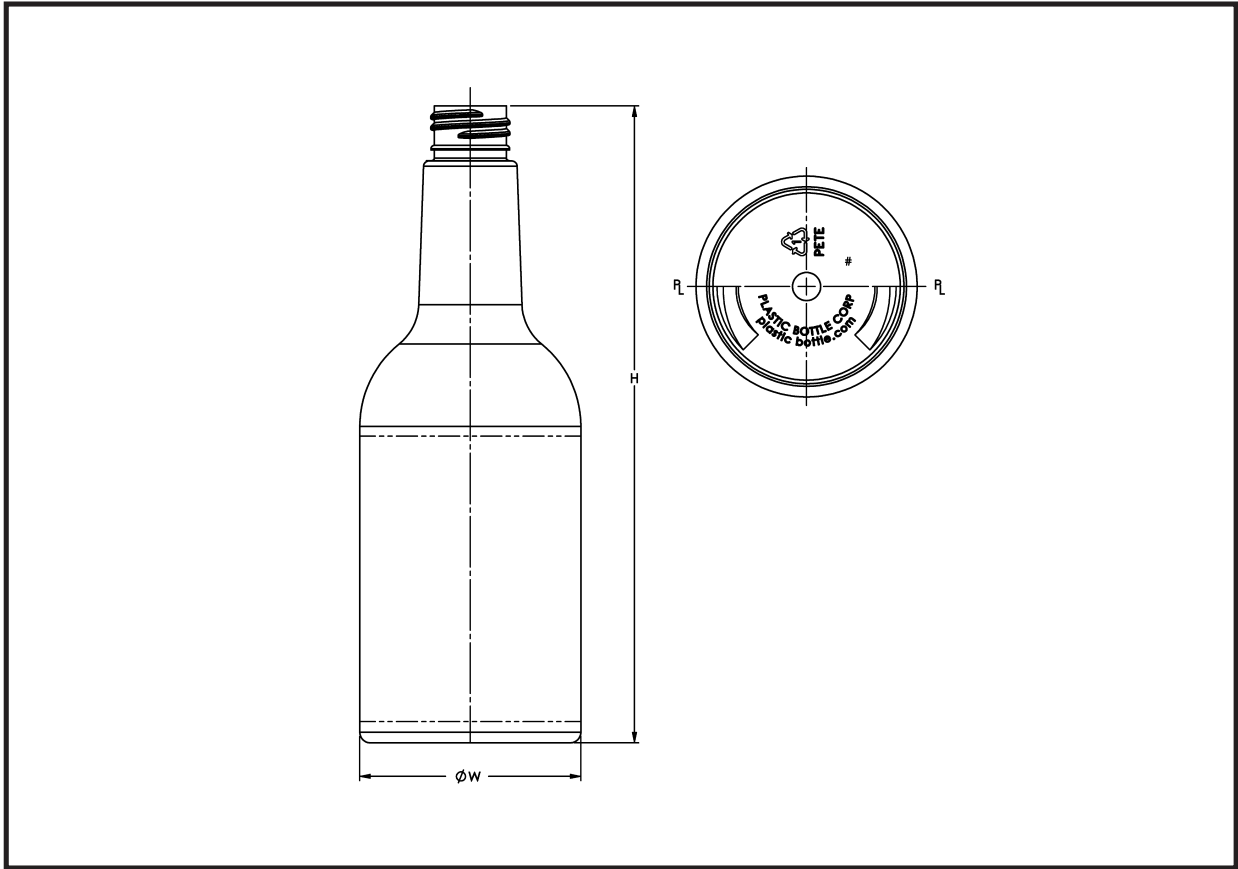

ROMAN ROUND

CAPACITY	NECKS	MATERIAL	HEIGHT	DIAMETER
12 oz	24-410	OPET	7.5"	2.60"
12 oz	24-415	OPET	7.881"	2.60"
32 oz / 1 Liter	28-400	OPET	10.70"	3.425"
32 oz / 1 Liter	28mm Kerr Tamper Evident	OPET	10.994"	3.425"

CONE TOP ROUNDS

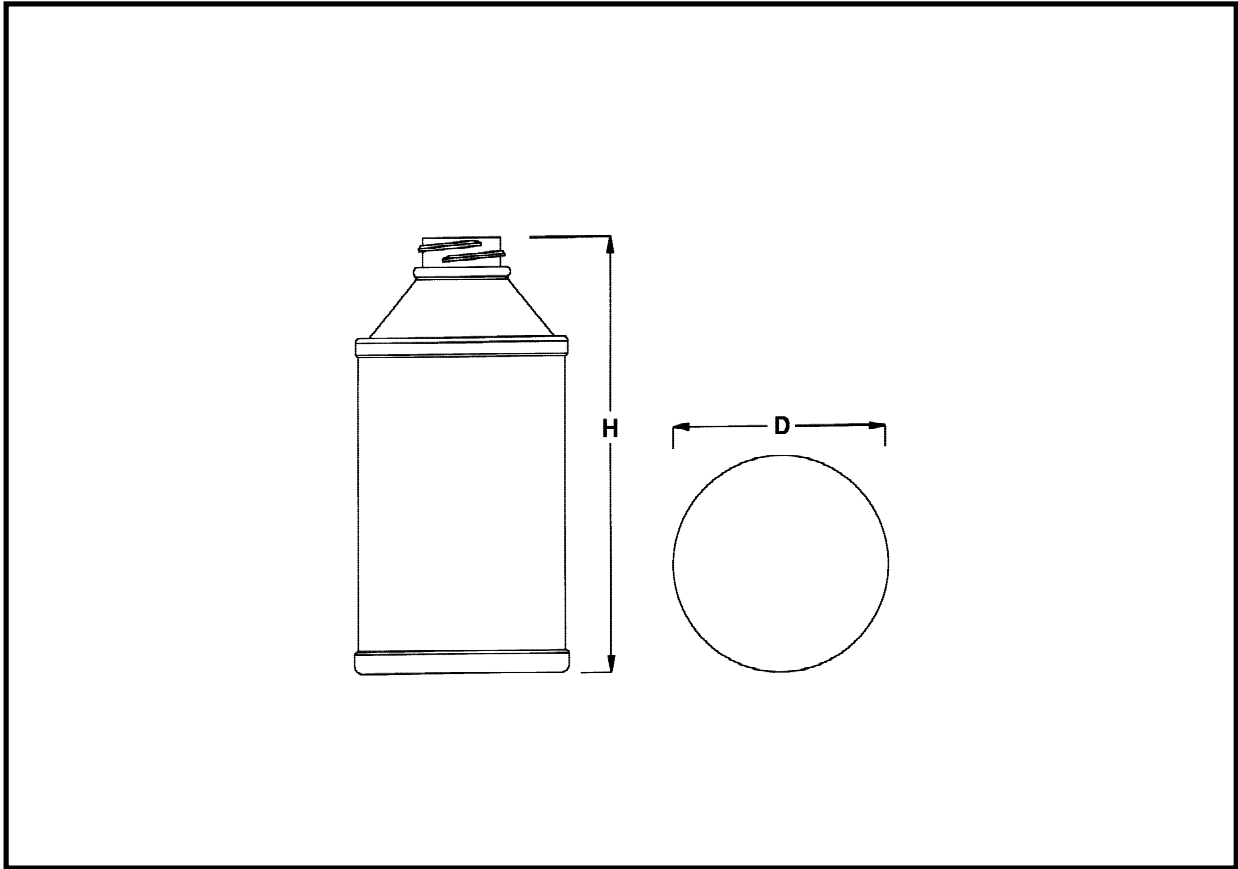

CONE TOP ROUNDS

CAPACITY	NECKS	MATERIAL	HEIGHT	DIAMETER
8 oz* / 250 ml*	28-400	HDPE	4.58"	2.74"
12 oz / 350 ml	28-400	HDPE	5.65"	2.74"
16 oz* / 500 ml*	28-400	HDPE	7.29≈	2.74≈

* Available with or without view stripe.

CONE TOP ROUND II

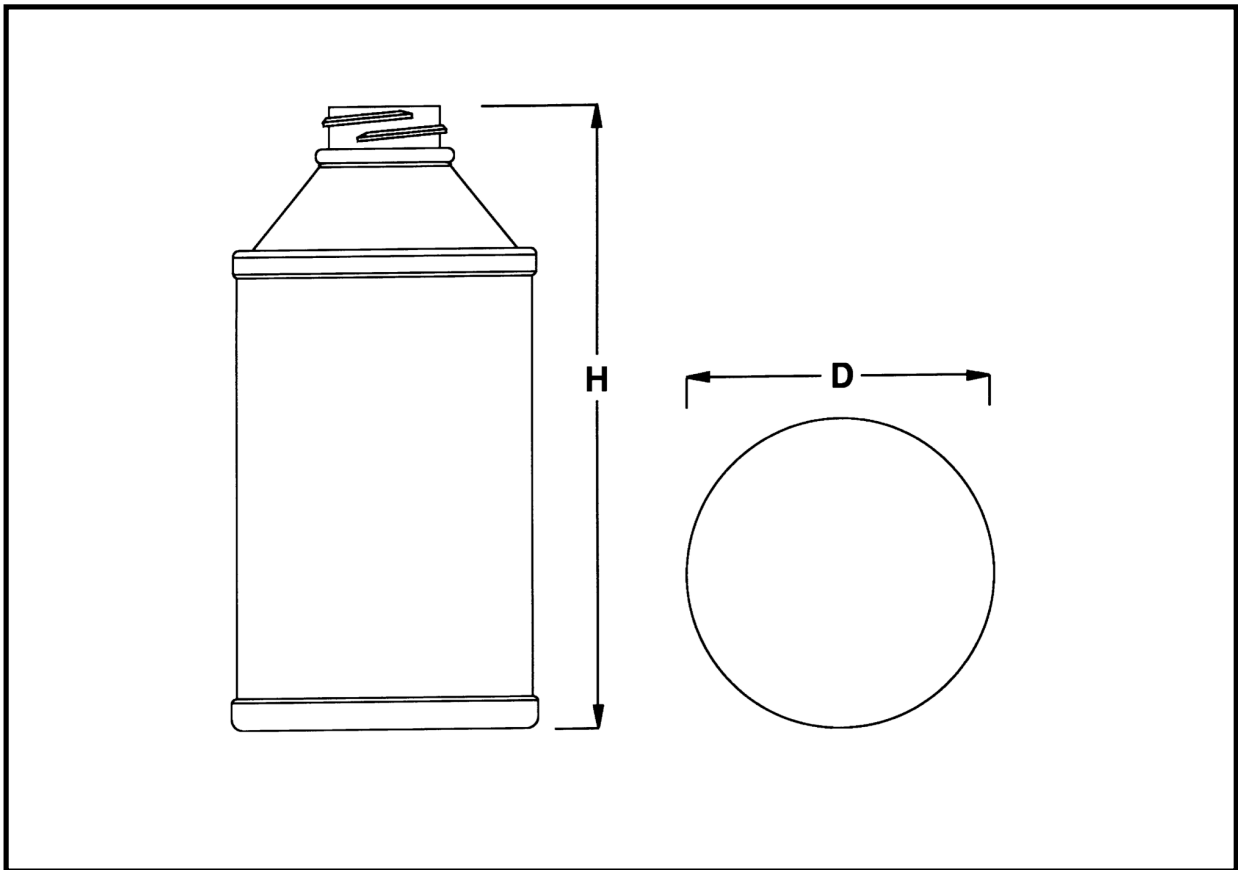

CONE TOP ROUND II

CAPACITY	NECKS	MATERIAL	HEIGHT	DIAMETER
12 oz / 350 ml	28-400	HDPE	5.72"	2.75"
32 oz / 1 Liter	28-400	HDPE	8.755"	3.486"

CONE TOP ROUND

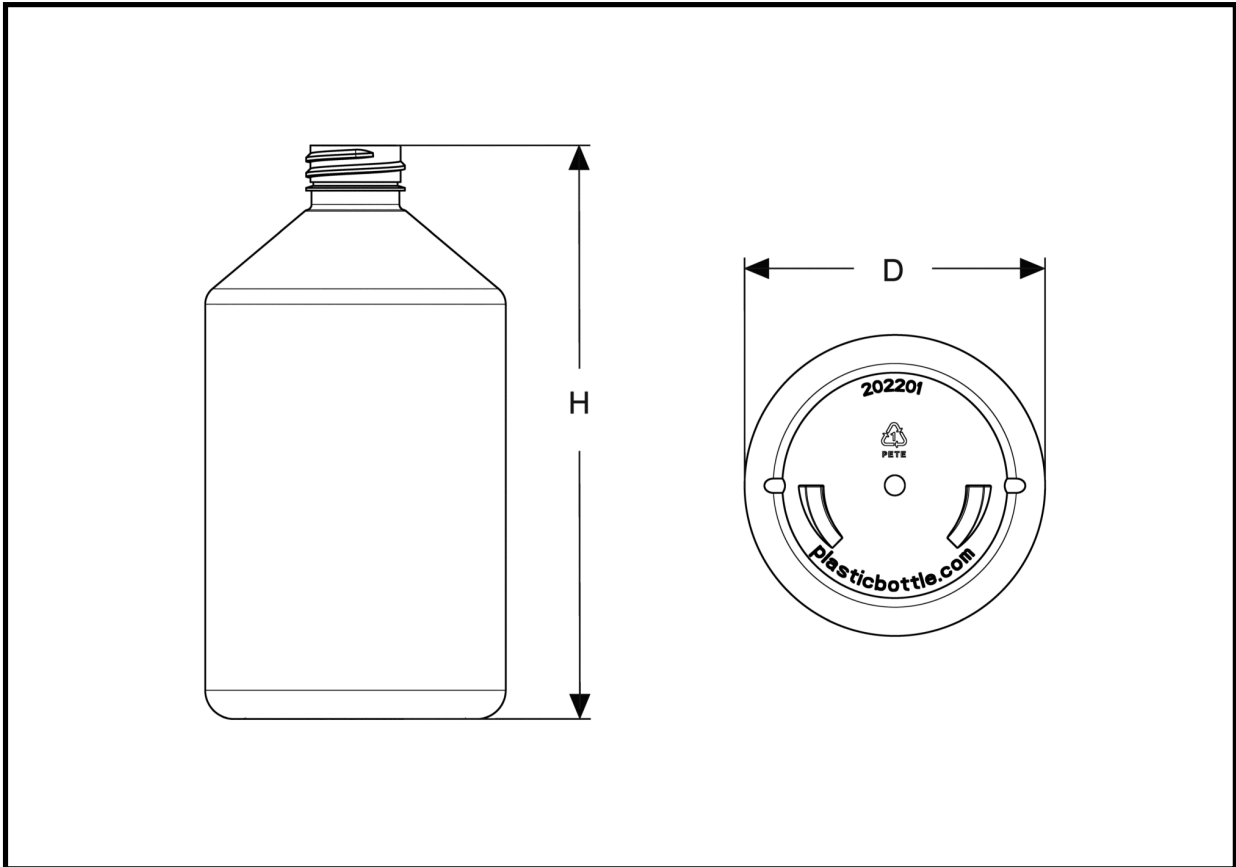

CONE TOP ROUND

CAPACITY	NECKS	MATERIAL	HEIGHT	DIAMETER
22 oz	28-410	OPET	6.25"	3.28"

CONE TOP ROUNDS

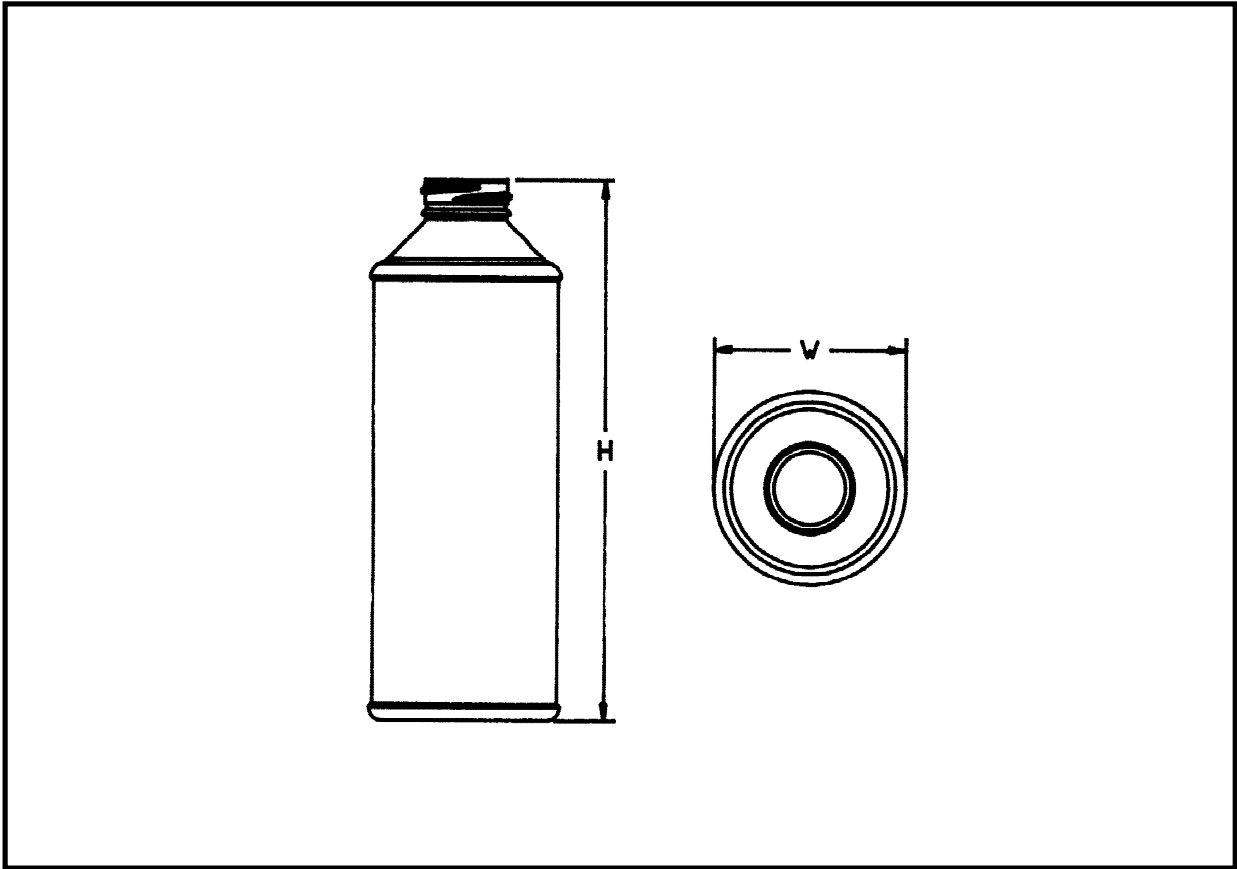

CONE TOP ROUNDS

CAPACITY	NECKS	MATERIAL	HEIGHT	DIAMETER
16 oz / 500ml	28-400	OPET	7.64"	2.685"

PLASTIC CAN

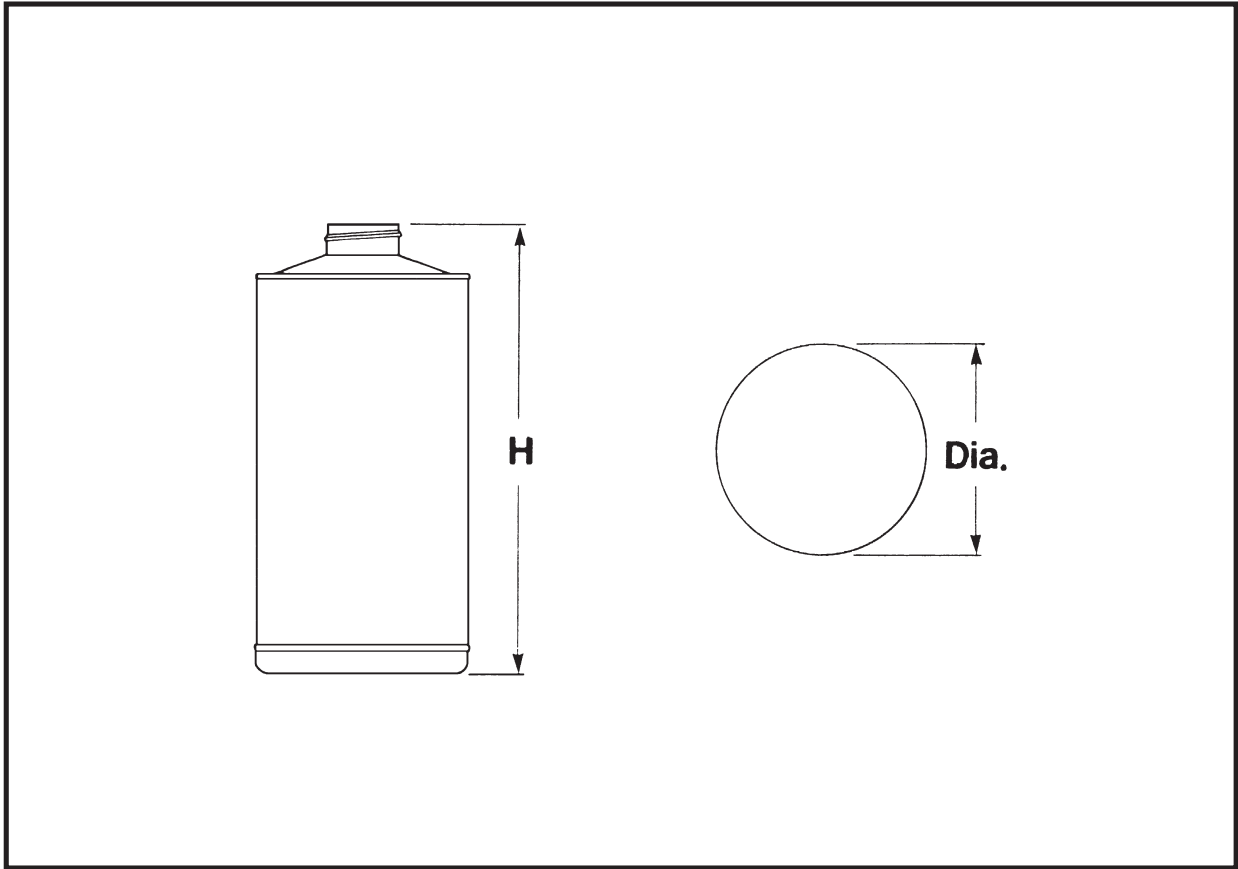

PLASTIC CAN

CAPACITY	NECKS	MATERIAL	HEIGHT	DIAMETER
12 oz	24-400	HDPE	5.83"	2.55"

FLUTED ROUND

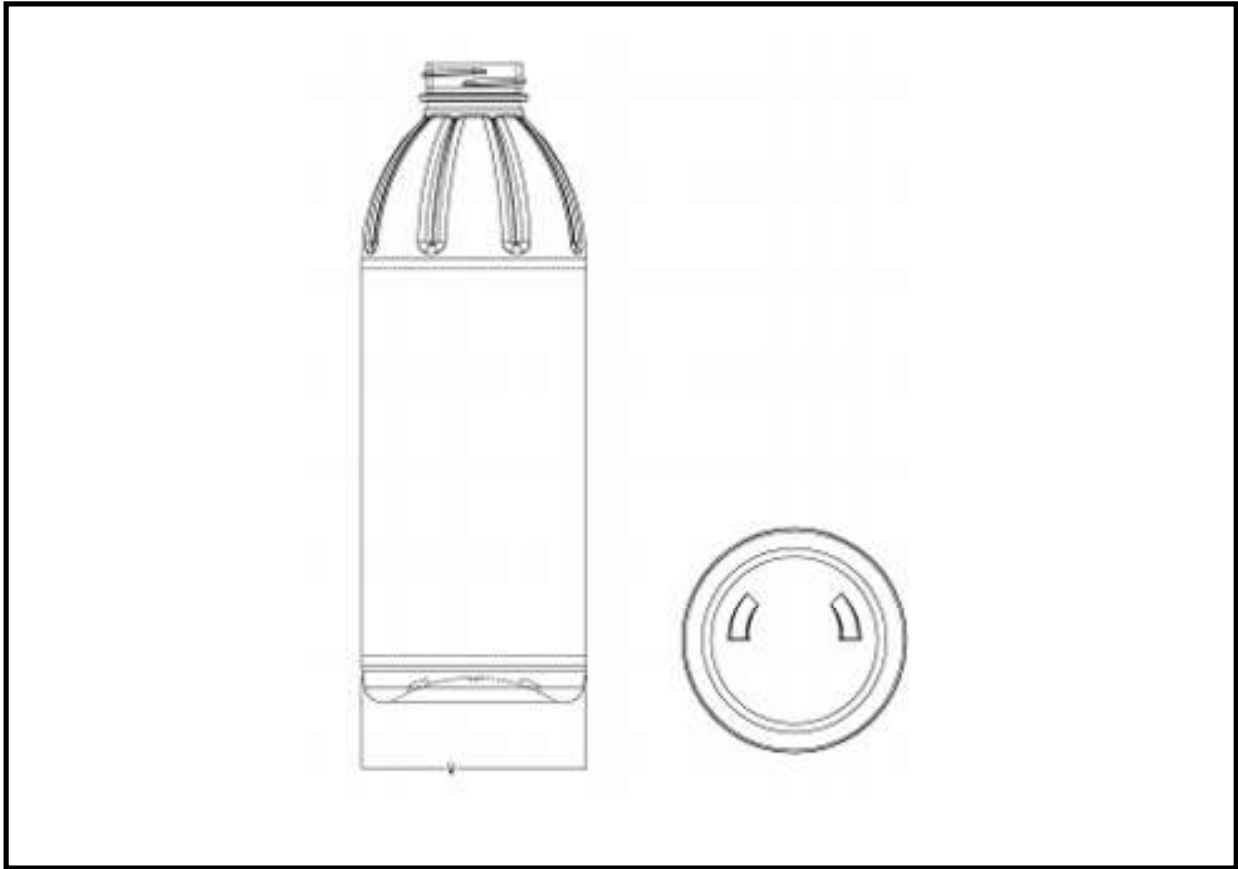

FLUTED ROUND

CAPACITY	NECKS	MATERIAL	HEIGHT	DIAMETER
16 oz	38-400	OPET	7.22"	2.60"
32 oz	38-400	OPET	9.13"	3.208"

RINGED CARAFES

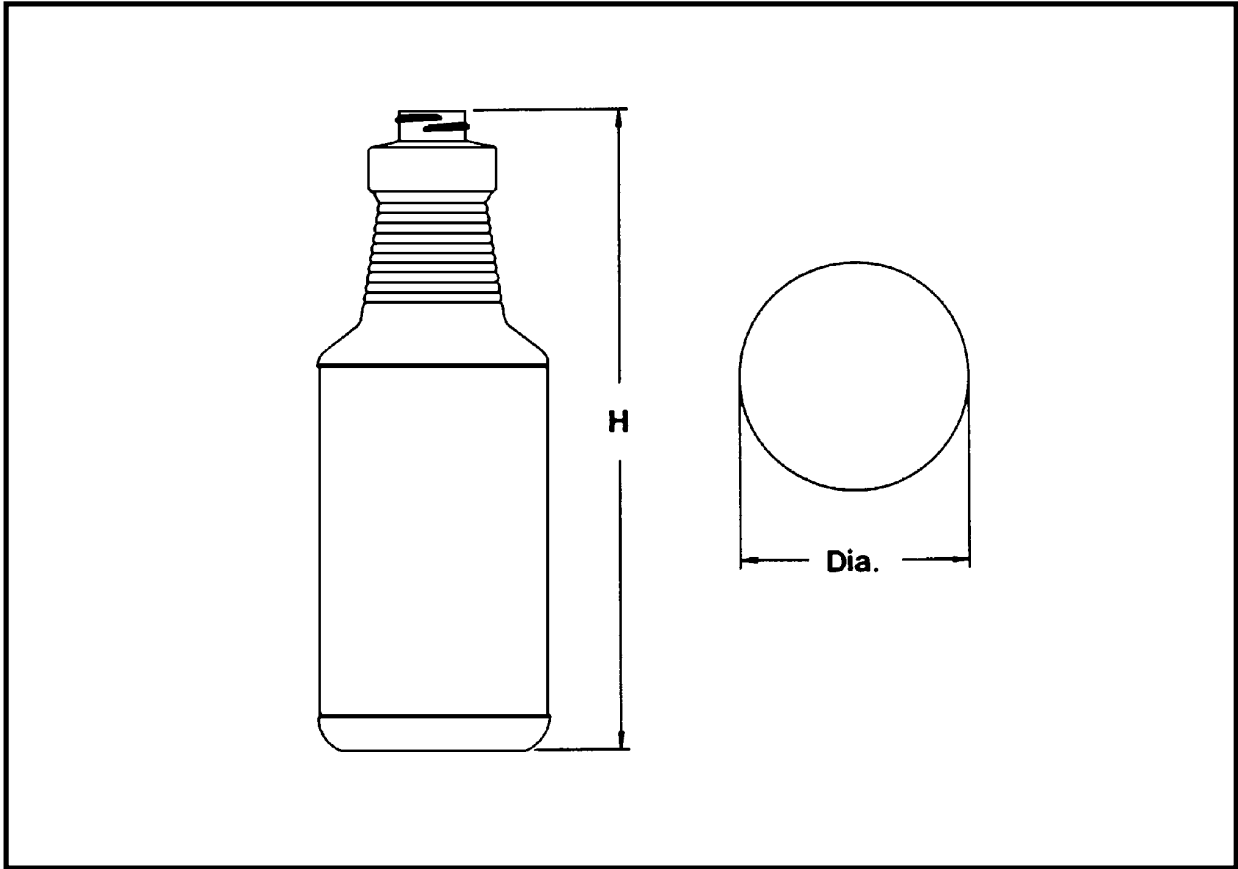

RINGED CARAFES

CAPACITY	NECKS	MATERIAL	HEIGHT	DIAMETER
16 oz	28-400	PVC	7.84"	2.74"
500 ml	28-400	PVC	8.12"	2.74"
16 oz*	28-400 .415" H	HDPE	7.63"	2.74"
16 oz*	28-400 .460" H	HDPE	7.675"	2.74"
16 oz*	28-410	HDPE	7.90"	2.74"
16 oz*	38mm LT	HDPE	7.63"	2.74"

* Available with and without view striping

RINGED CARAFES

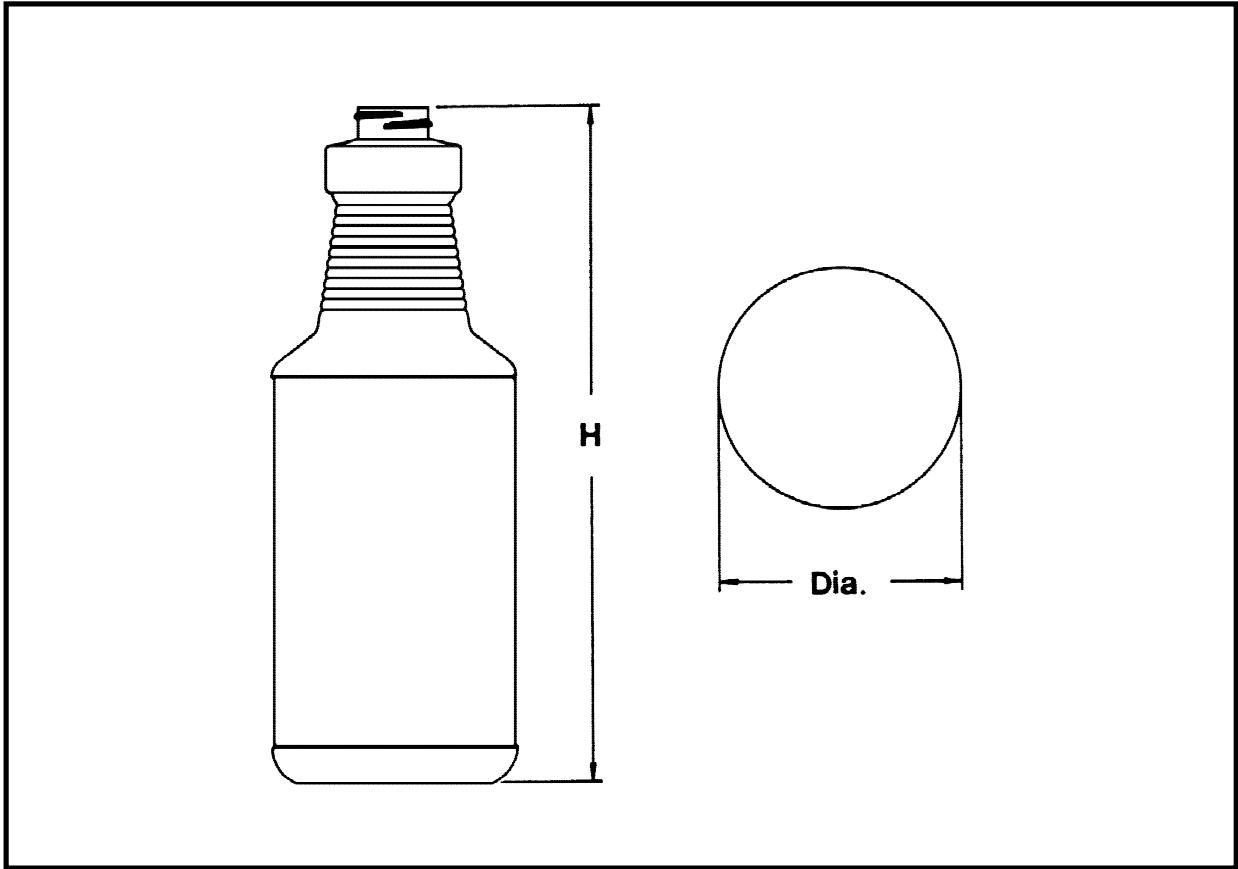

RINGED CARAFES

CAPACITY	NECKS	MATERIAL	HEIGHT	DIAMETER
32 oz / 1 Liter	28-400	PVC	9.67"	3.44"
32 oz	28-410	PVC	9.97"	3.44"

See pages 43 and 46 for additional HDPE Ringed choices.

RINGED CARAFES

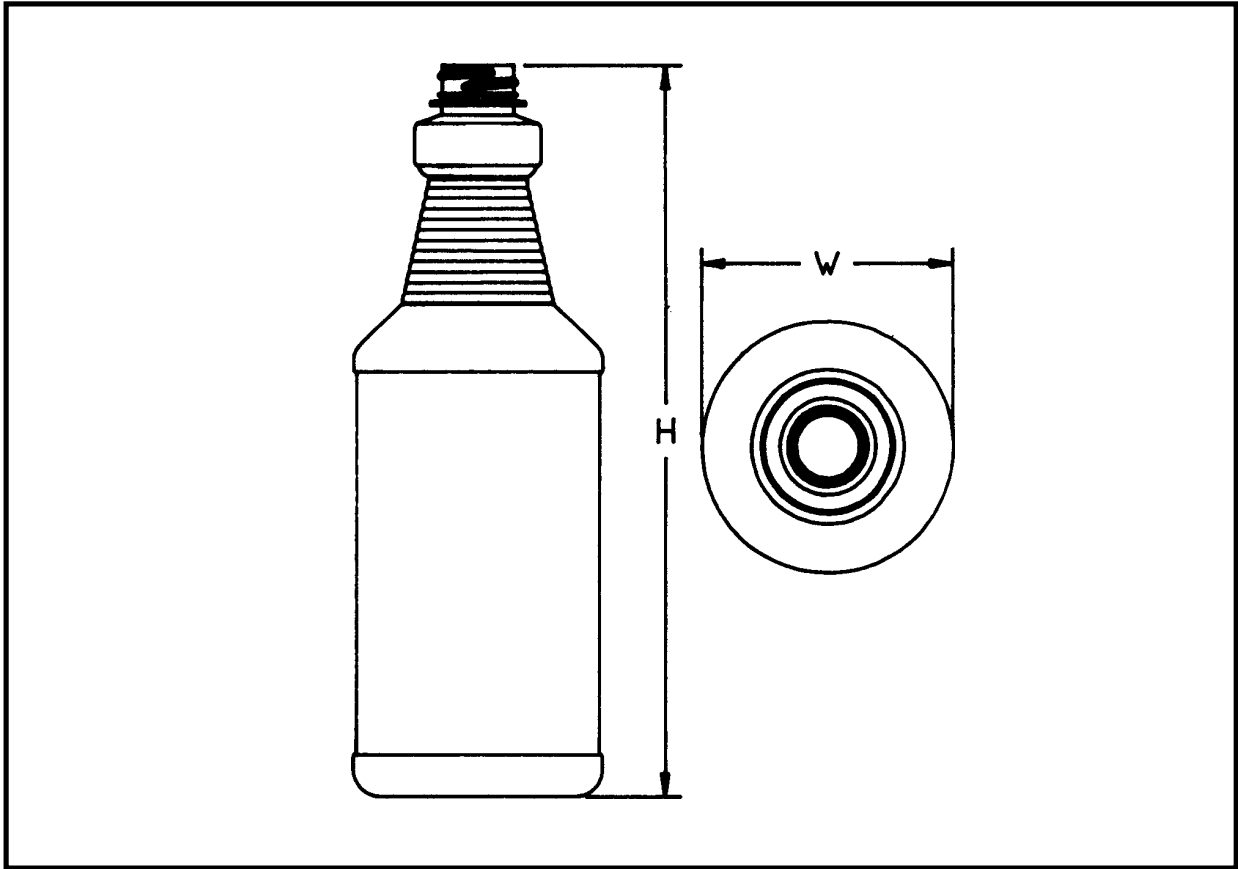

RINGED CARAFES

CAPACITY	NECKS	MATERIAL	HEIGHT	DIAMETER
32 oz	28-400	OPET	10.028"	3.406"
32 oz	28-410	OPET	10.27"	3.406"

RINGED CARAFES

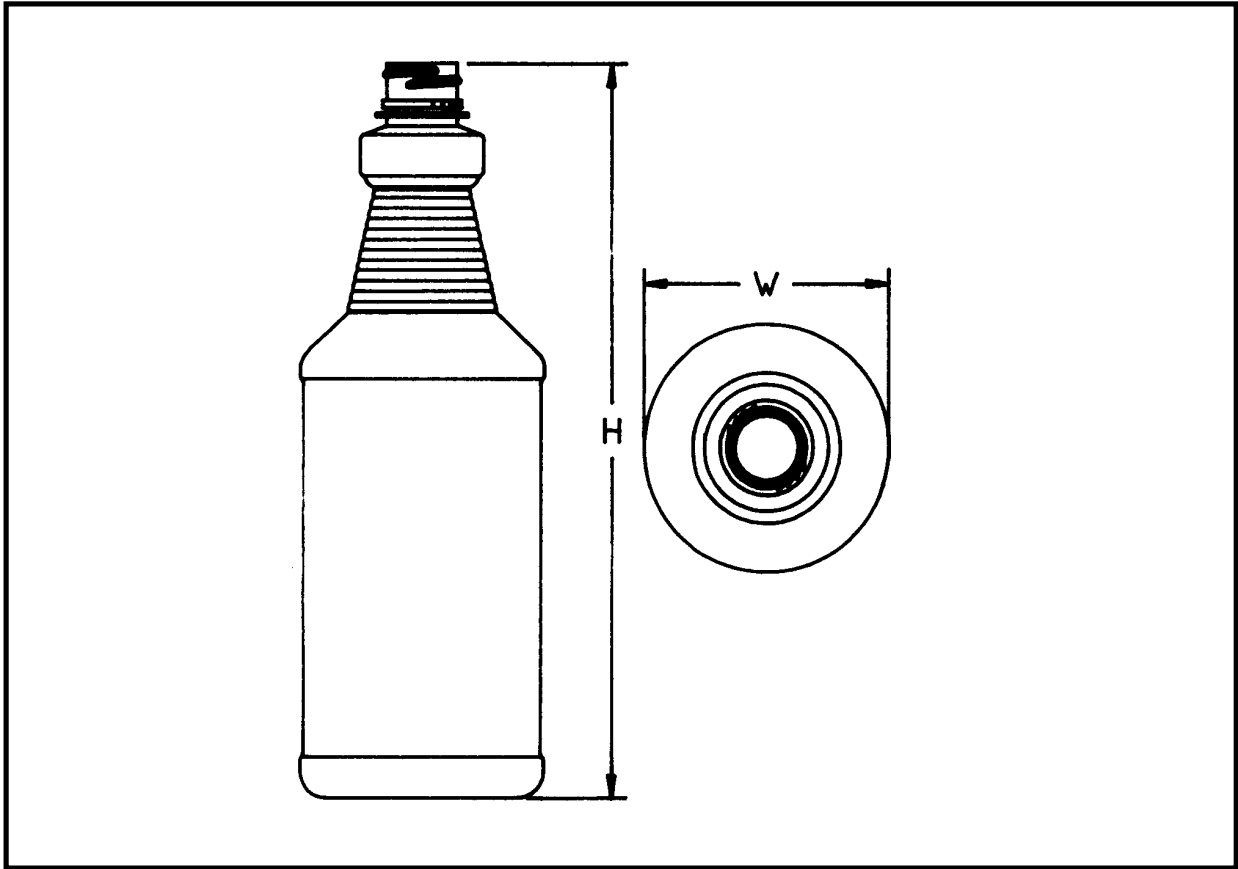

RINGED CARAFES

CAPACITY	NECKS	MATERIAL	HEIGHT	DIAMETER
32 oz	28mm Ratchet	OPET	10.22"	3.406"

RINGED RIBBED CARAFE

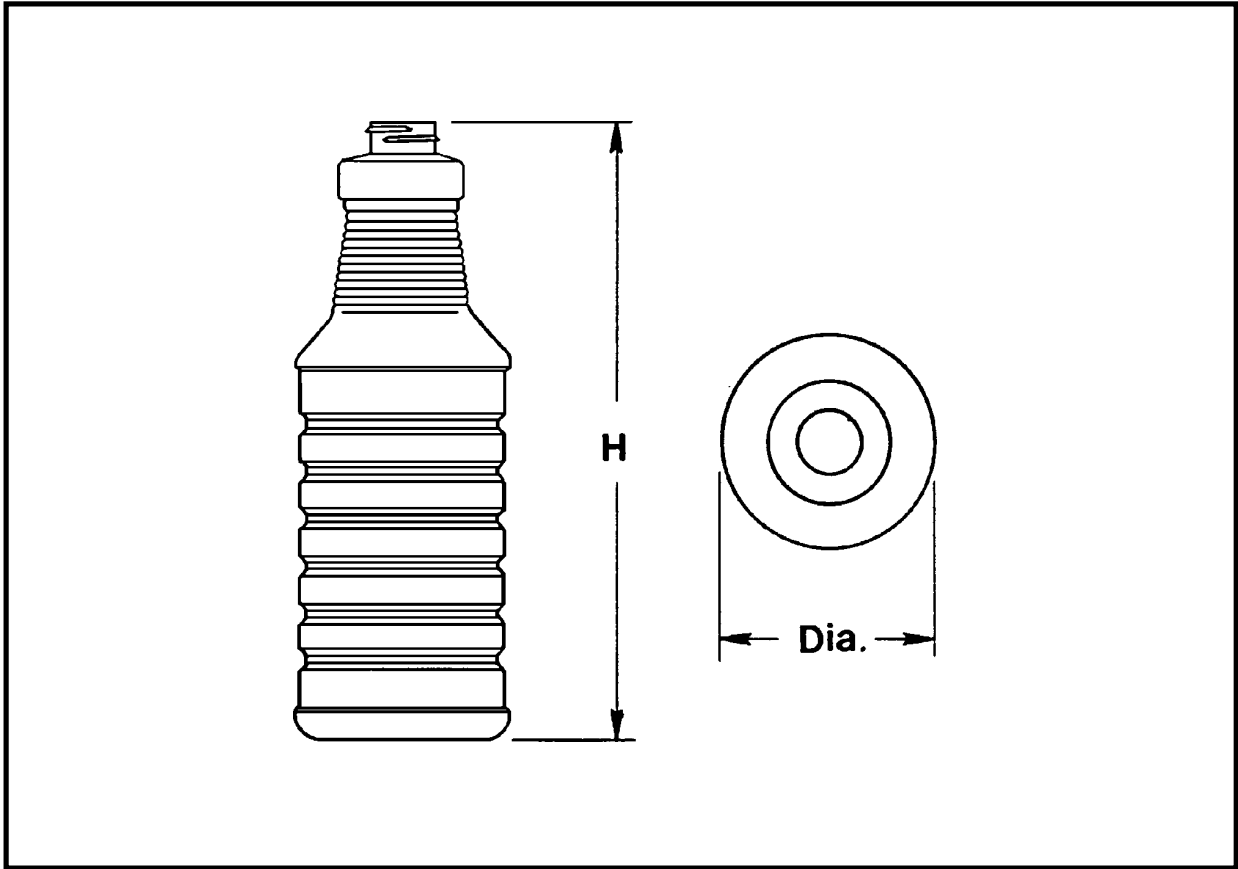

RINGED RIBBED CARAFE

CAPACITY	NECKS	MATERIAL	HEIGHT	DIAMETER
32 oz	28-400 Ramp	PVC	9.67"	3.44"
1 Liter	28-400 Ramp	PVC	9.67"	3.44"

GRADUATED SERVICE ROUND

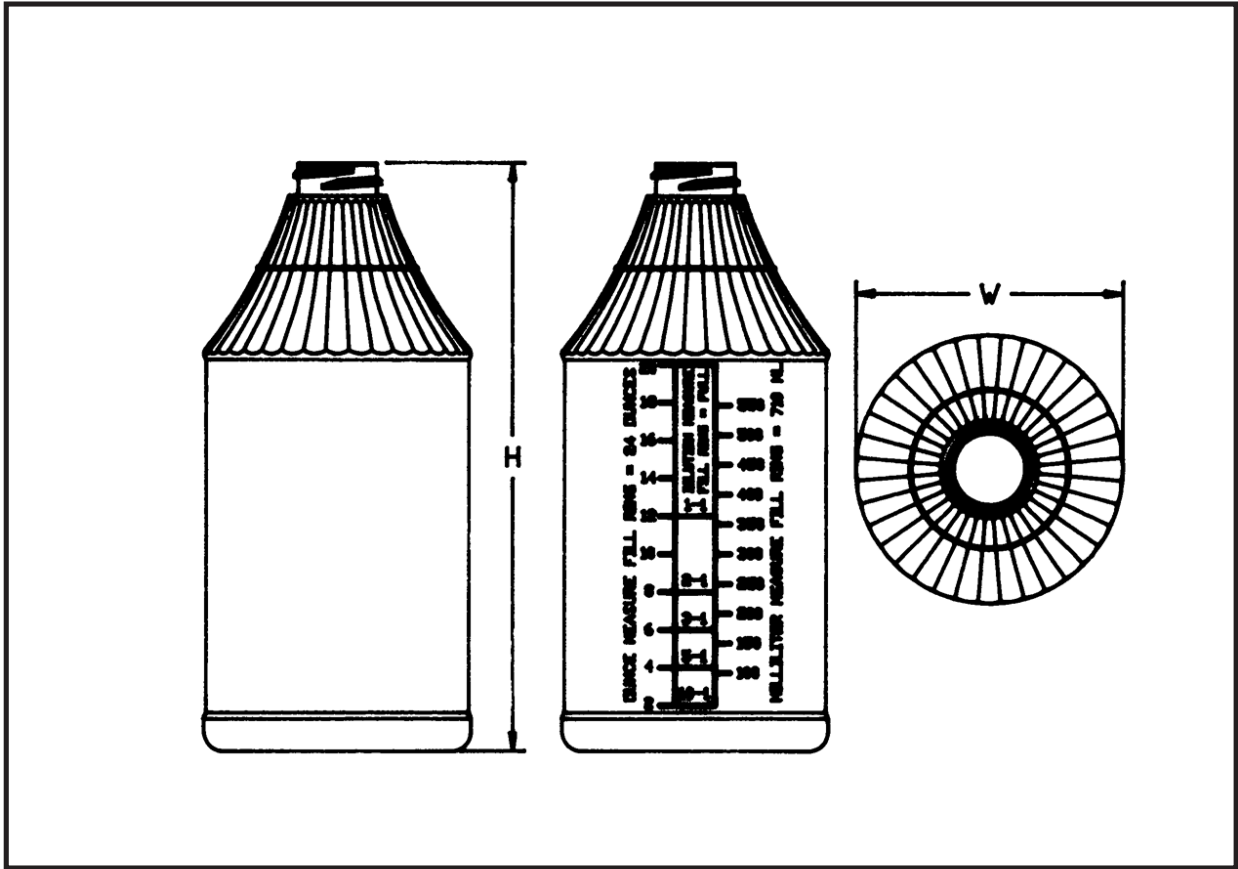

GRADUATED SERVICE ROUND

CAPACITY	NECKS	MATERIAL	HEIGHT	DIAMETER
24 oz	28-400 Ramp	HDPE	7.25"	3.31"

#503242 FLUTED CARAFE

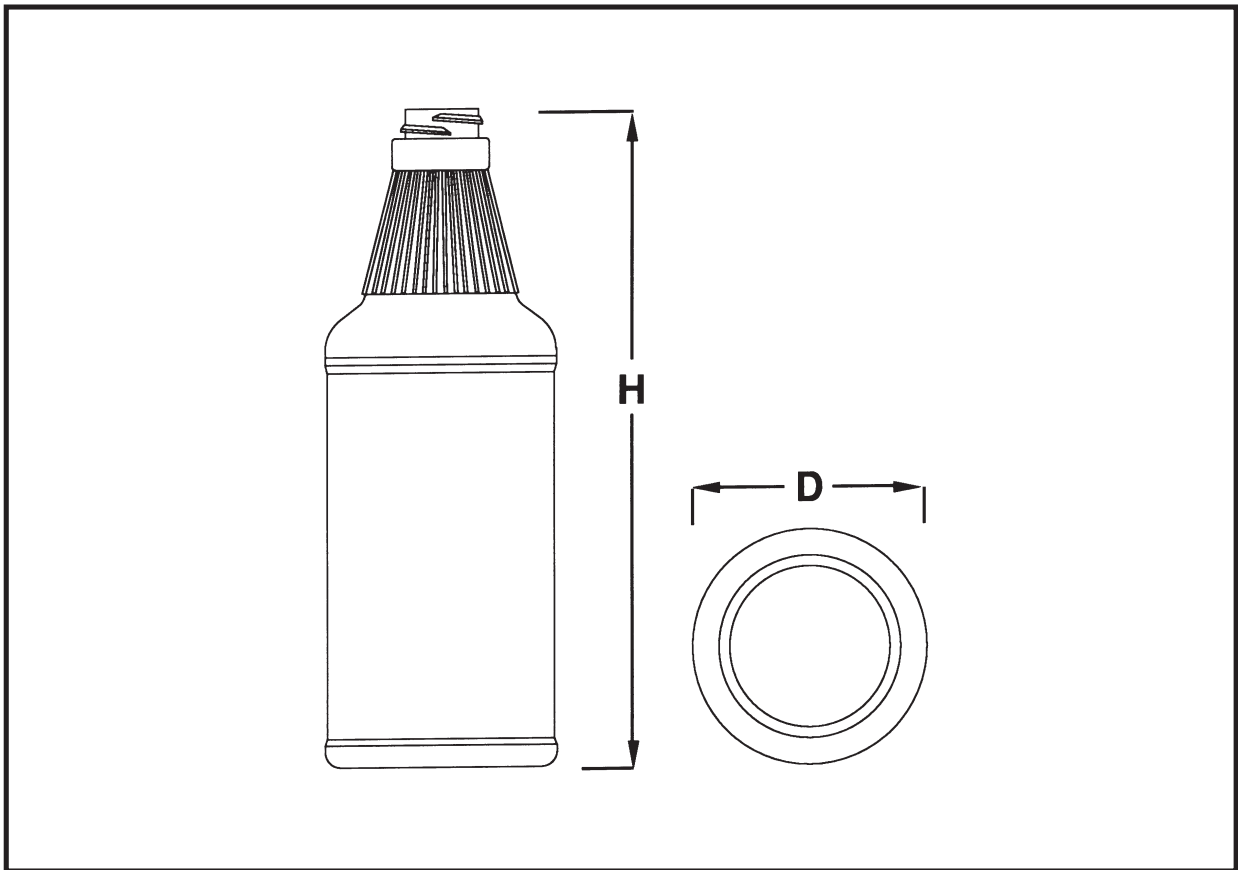

#503242 FLUTED CARAFE

CAPACITY	NECKS	MATERIAL	HEIGHT	DIAMETER
32 oz	28-400 Ramp	HDPE	9.62"	3.43"
32 oz	28-400 Ramp .450" H	HDPE	9.675"	3.43"
32 oz	28-410	HDPE	9.93"	3.43"
32 oz	28mm PS211	HDPE	9.86"	3.43"

#503242 RINGED CARAFE

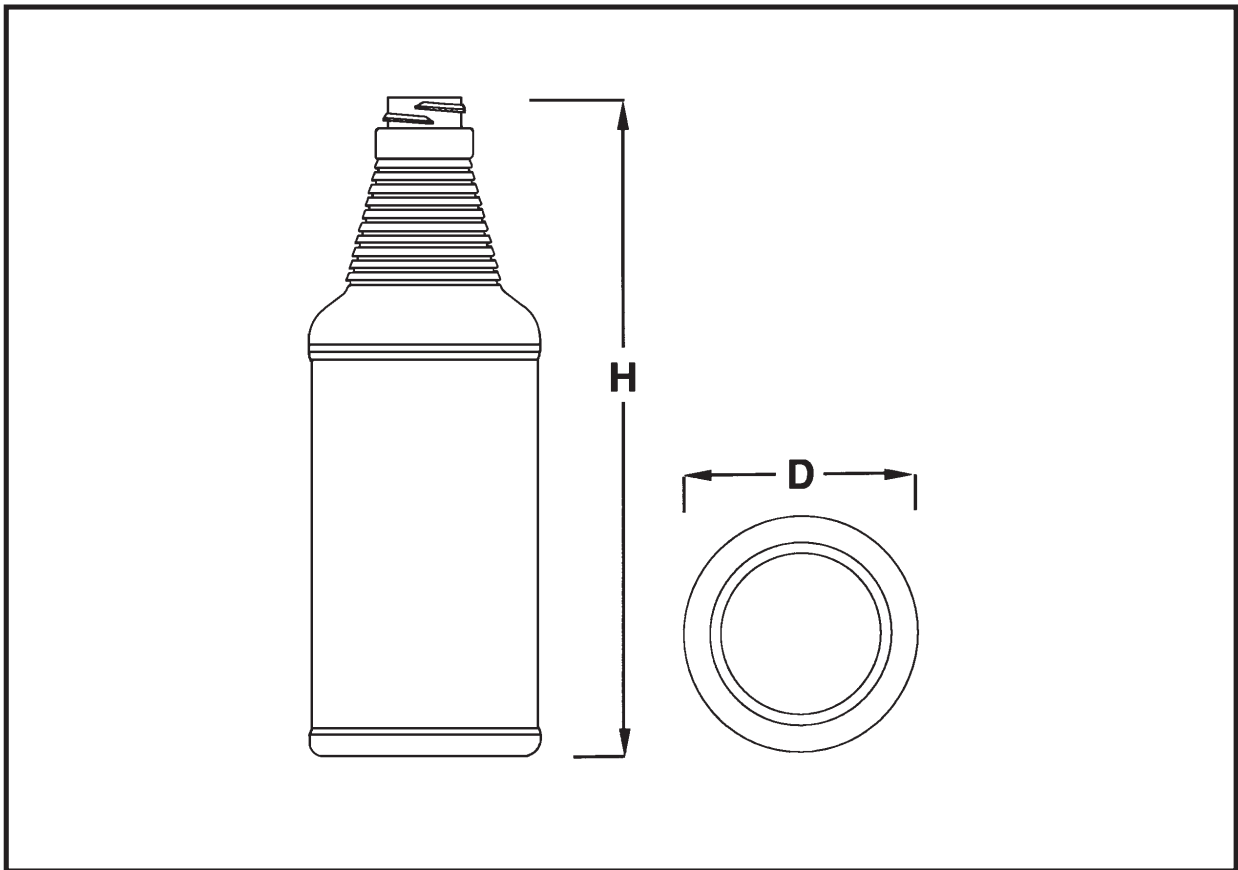

#503242 RINGED CARAFE

CAPACITY	NECKS	MATERIAL	HEIGHT	DIAMETER
32 oz	28-400 Ramp	HDPE	9.62"	3.43"
32 oz	28-400 Ramp .450" H	HDPE	9.675"	3.43"
32 oz	28-410	HDPE	9.93"	3.43"
32 oz	28mm PS211	HDPE	9.86"	3.43"

SASSY ROUND

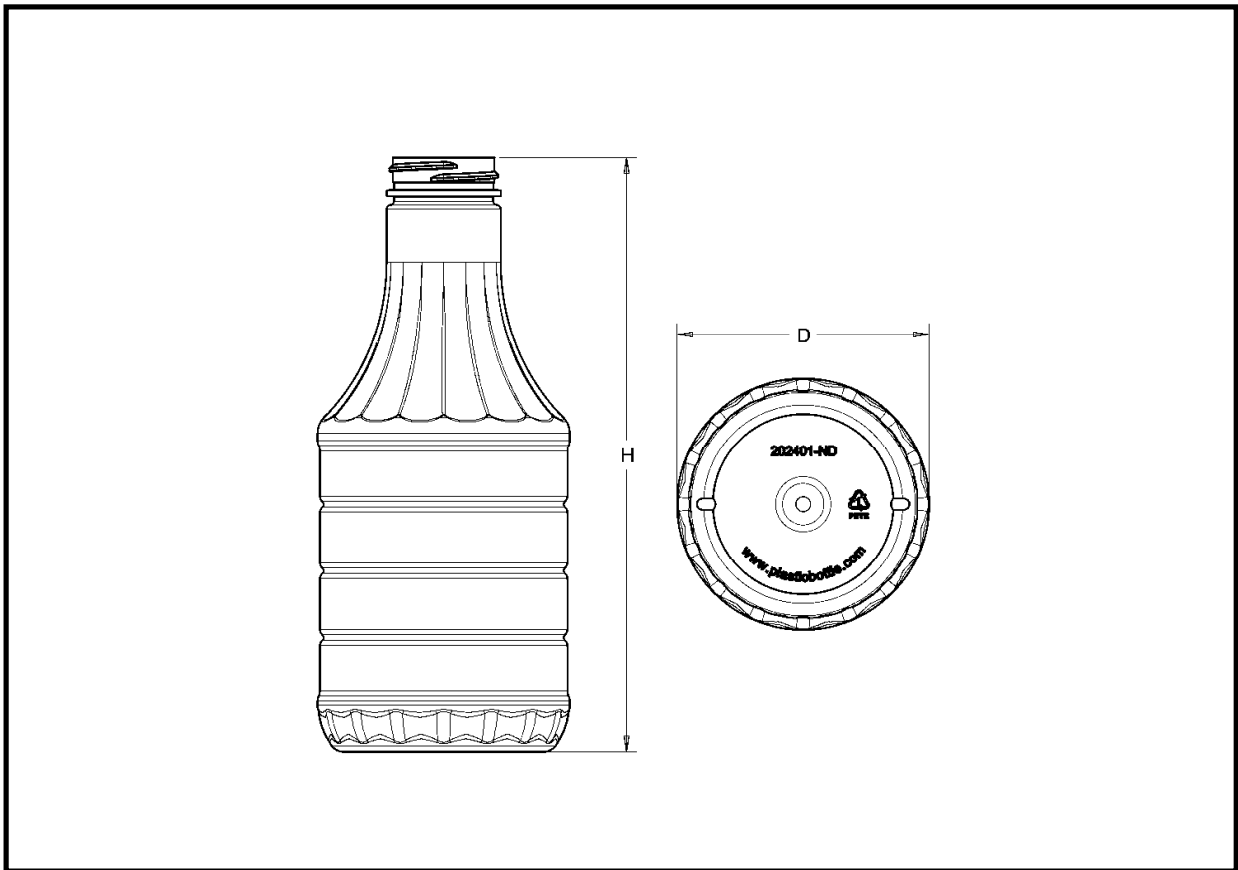

SASSY ROUND

CAPACITY	NECKS	MATERIAL	HEIGHT	DIAMETER
24 oz	38-400	OPET	8.014"	3.40"

GIRAFFE CARAFE

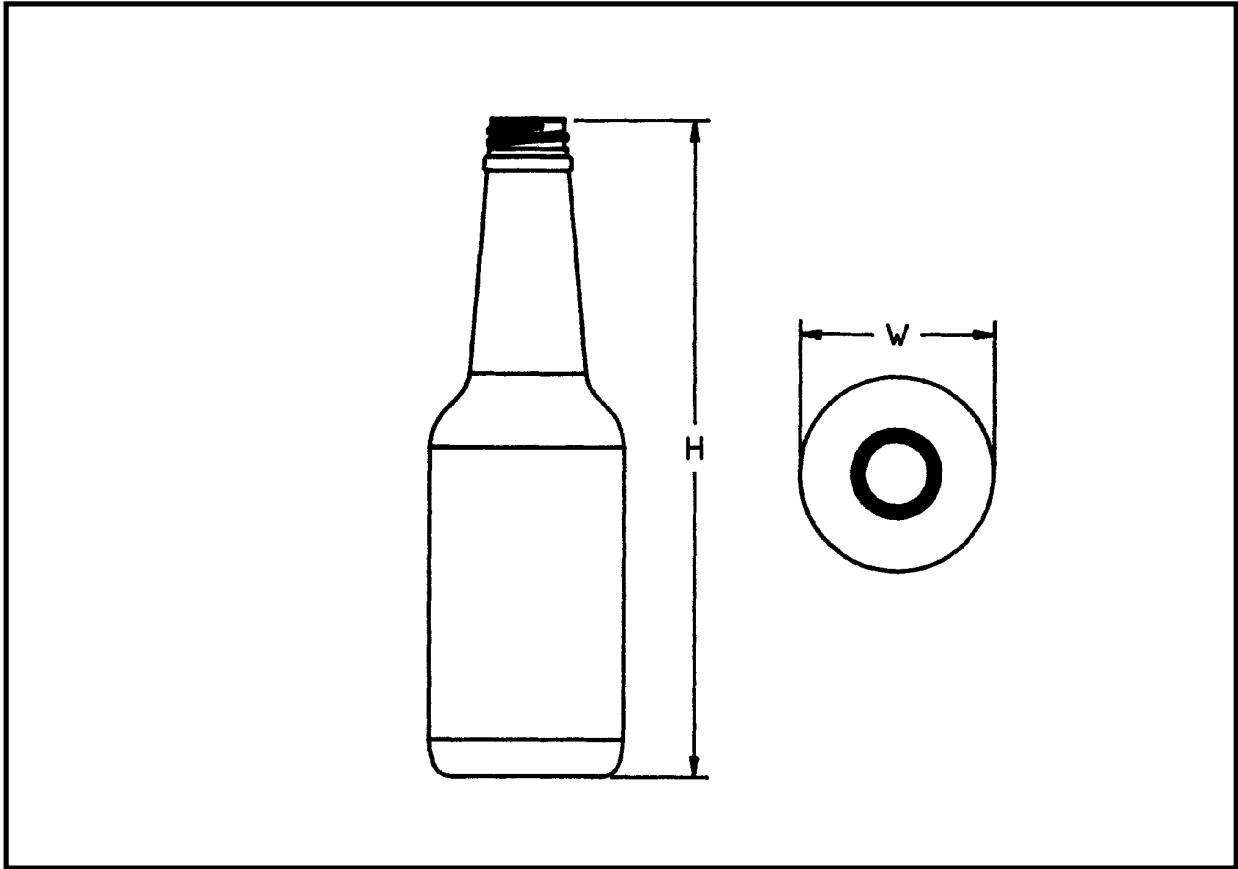

GIRAFFE CARAFE

CAPACITY	NECKS	MATERIAL	HEIGHT	DIAMETER
16 oz	28-400	PVC	8.85"	2.625"

For a 50,000 piece order, we could look at building an OPET version.

HYBRID ROUNDS

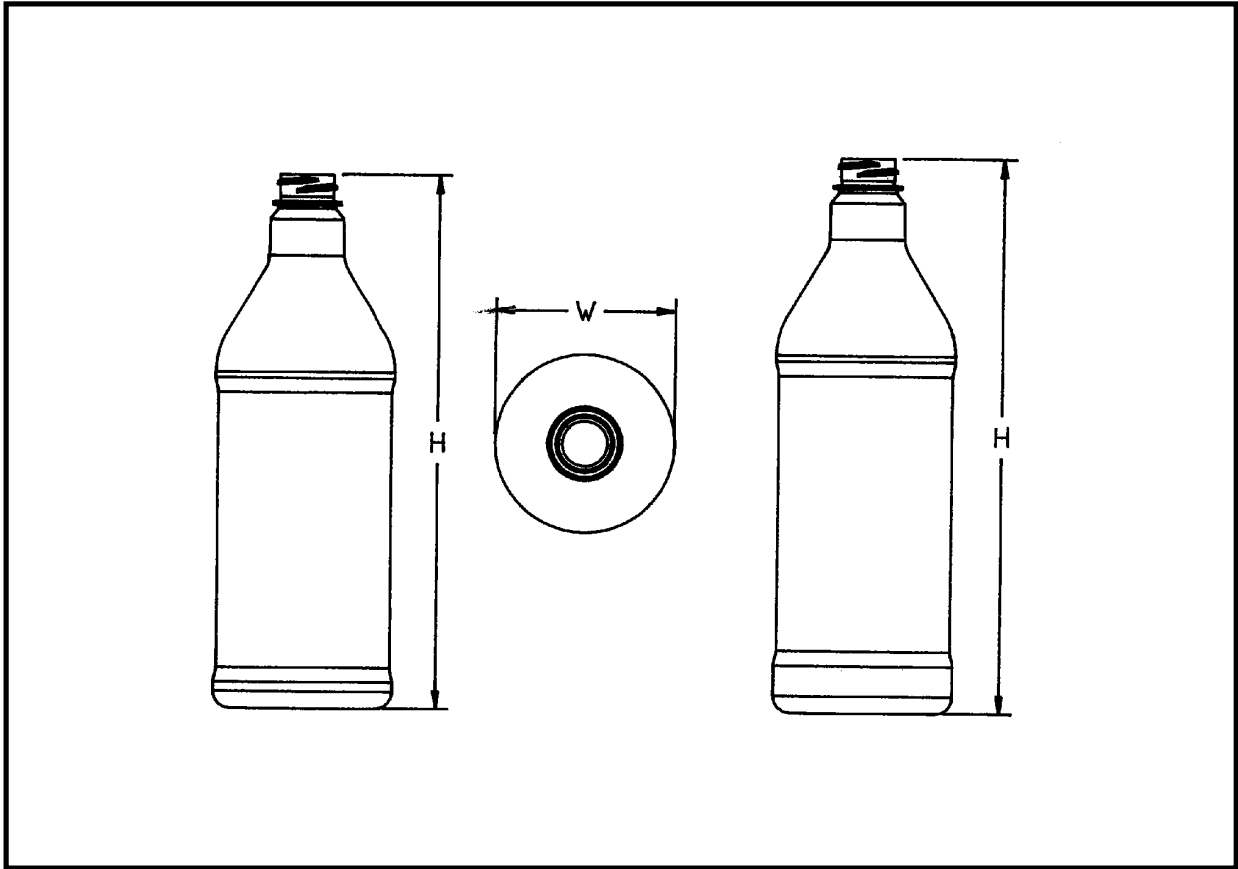

HYBRID ROUNDS

CAPACITY	NECKS	MATERIAL	HEIGHT	DIAMETER
32 oz	28-400T .460" H	OPET	9.888"	3.3"
32 oz	28mm Ratchet	OPET	10.11"	3.3"
1 Liter	28-400	OPET	10.278"	3.3"
1 Liter	28mm Ratchet	OPET	10.50"	3.3"

MXR ROUNDS

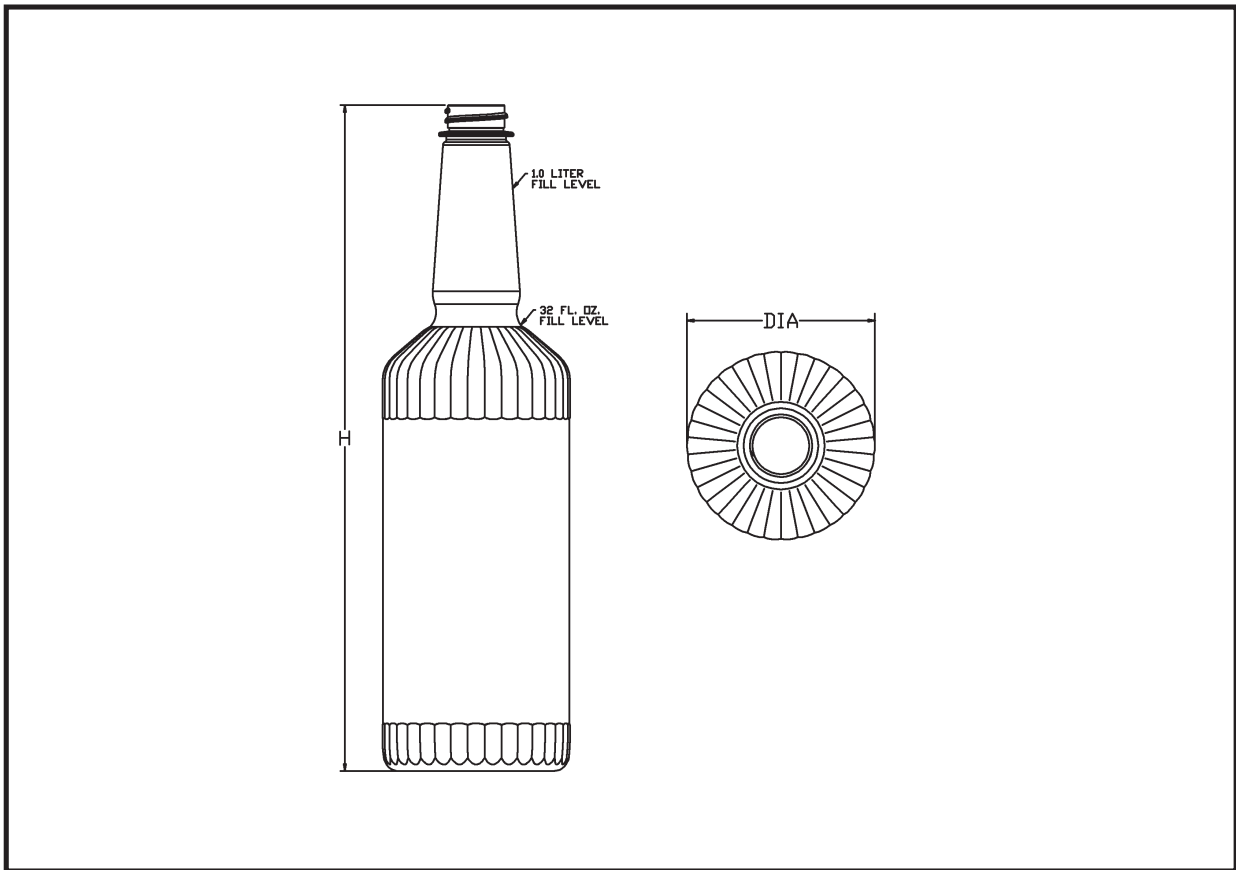

MXR ROUNDS

CAPACITY	NECKS	MATERIAL	HEIGHT	DIAMETER
32 oz / 1 Liter	28-400 .465"	OPET	11.5"	3.25"
32 oz / 1 Liter	28mm KERR Tamper Evident	OPET	11.791"	3.25"

JUBILATION ROUNDS

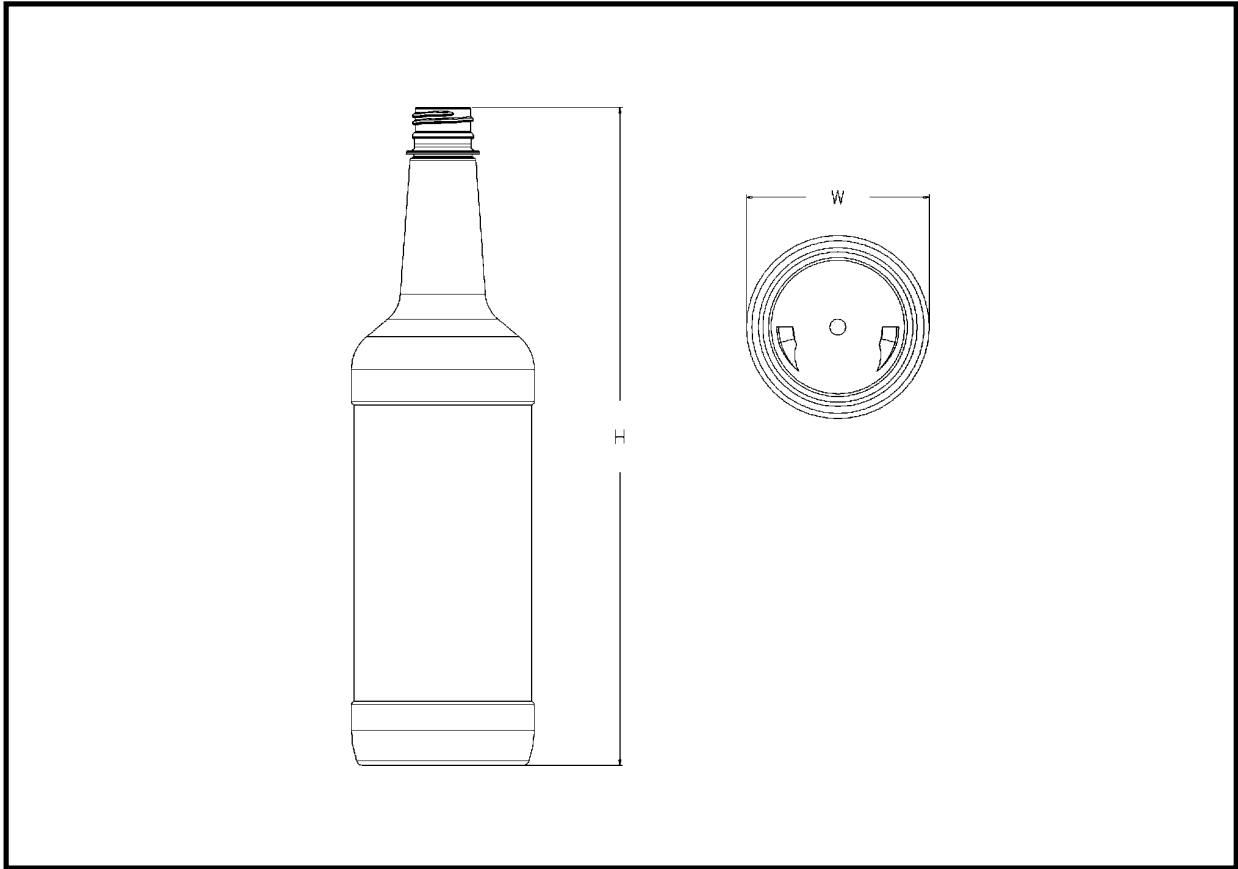

JUBILATION ROUNDS

CAPACITY	NECKS	MATERIAL	HEIGHT	DIAMETER
7 oz / 220 ml	24-410	OPET	7.313"	1.965"
32 oz / 1 Liter	28-400	OPET	11.381"	3.25"
32 oz / 1 Liter	28mm KERR Tamper Evident	OPET	11.675"	3.25"

JUBILATION II ROUND

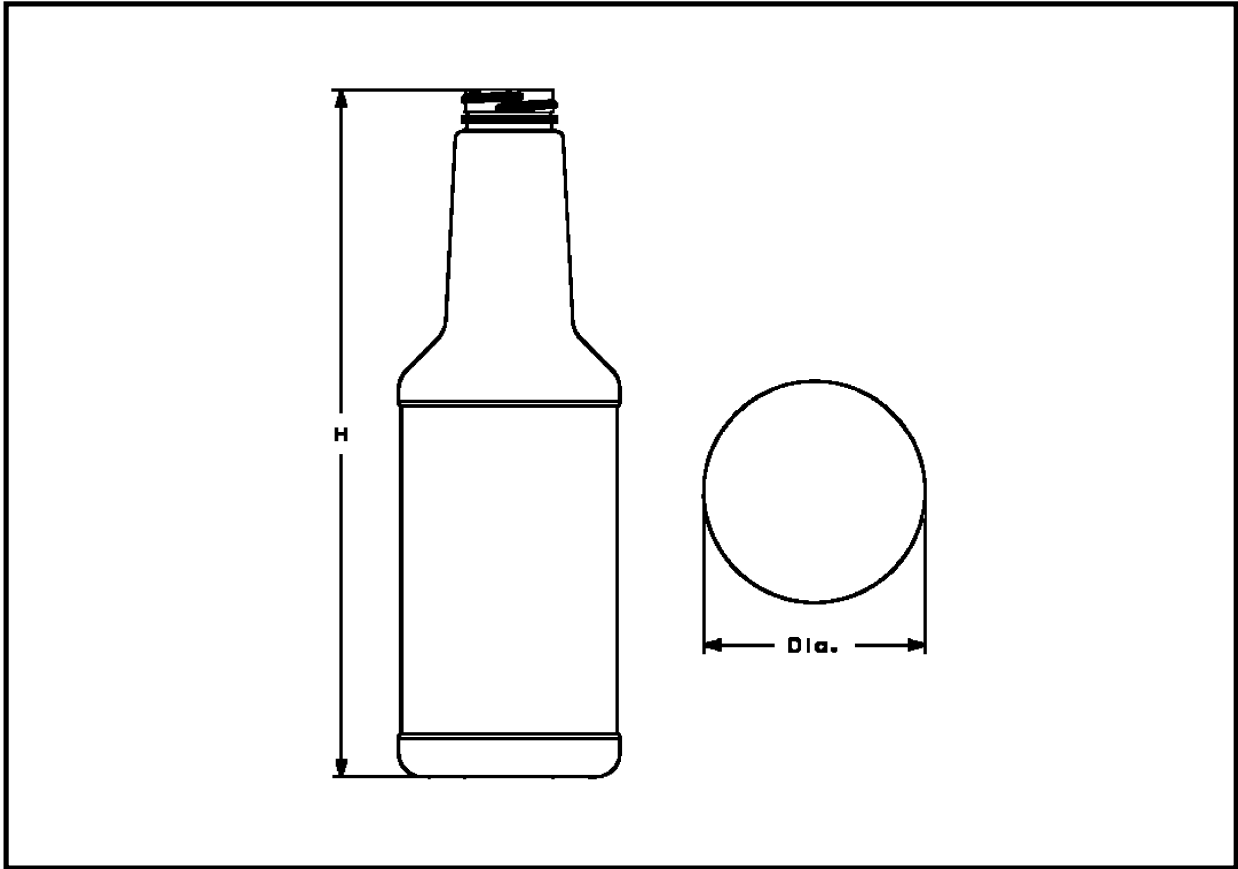

JUBILATION II ROUND

CAPACITY	NECKS	MATERIAL	HEIGHT	DIAMETER
32 oz / 1 Liter	38-400	OPET	10.7"	3.455"

#101 RINGED TOP ROUNDS

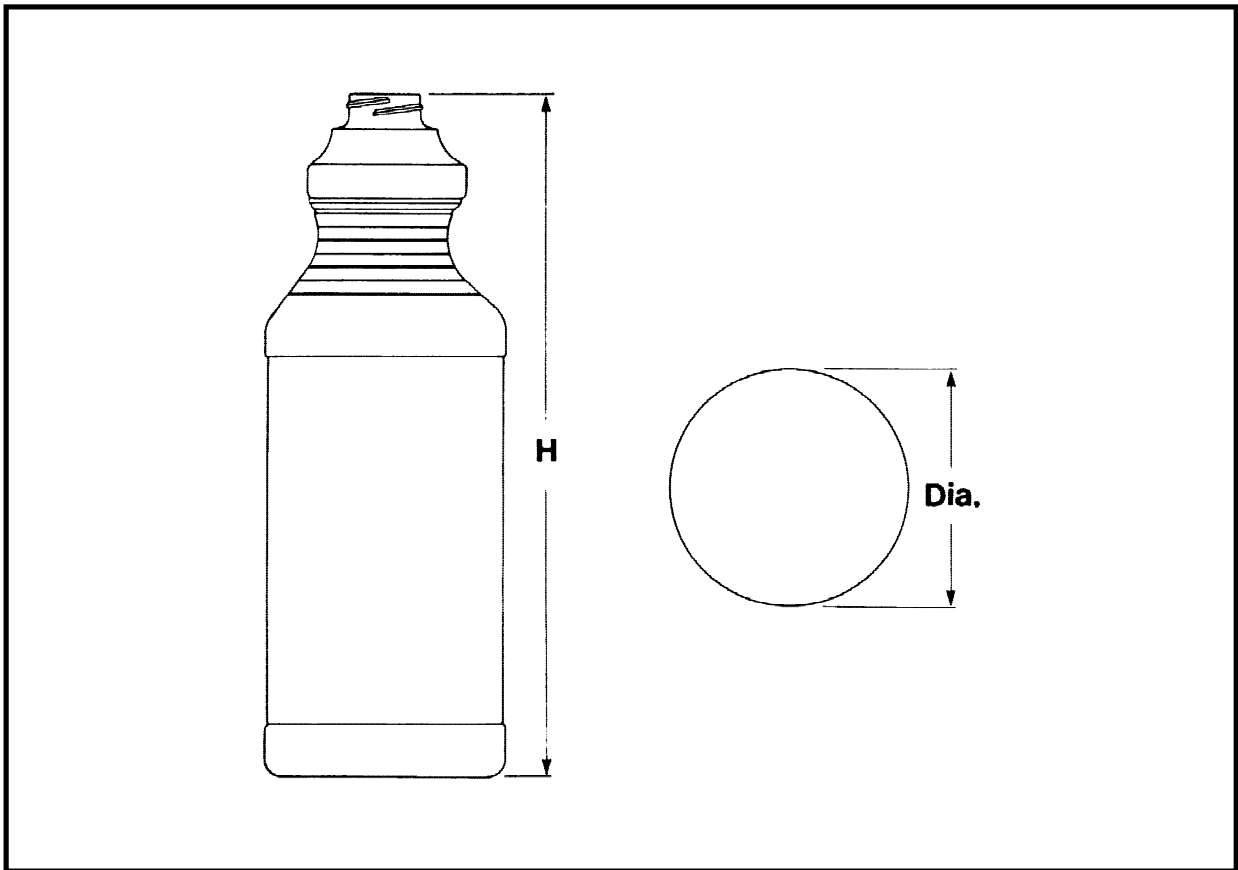

#101 RINGED TOP ROUNDS

CAPACITY	NECKS	MATERIAL	HEIGHT	DIAMETER
32 oz	28-400 .450≈H	HDPE	9.509"	3.40"
32 oz	33-400	HDPE	9.47"	3.40"

#102 RINGED CARAFES

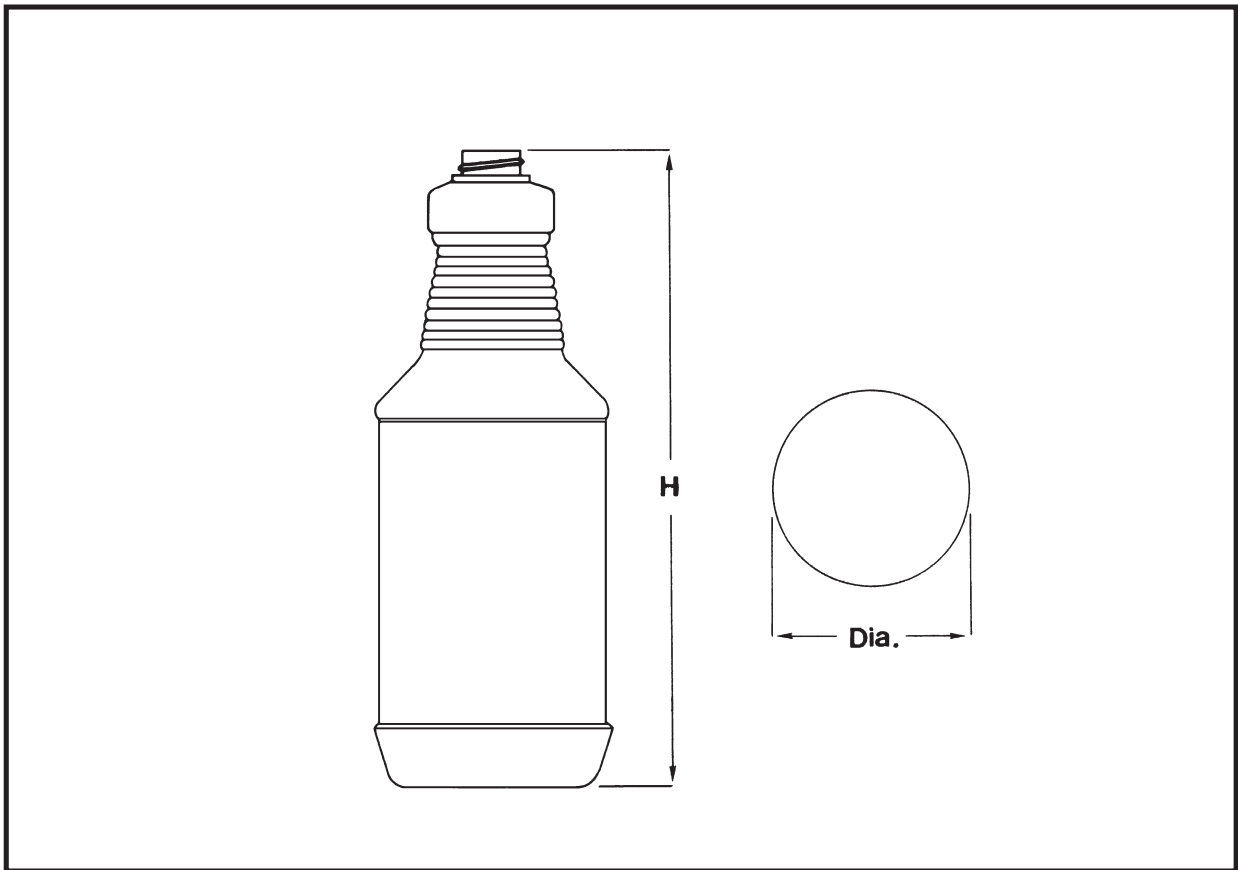

#102 RINGED CARAFES

CAPACITY	NECKS	MATERIAL	HEIGHT	DIAMETER
32 oz	28-400 Ramp	HDPE	9.59"	3.49"
32 oz	28-410	HDPE	9.87"	3.49"

Available with and without view striping.

#102 FLUTED CARAFES

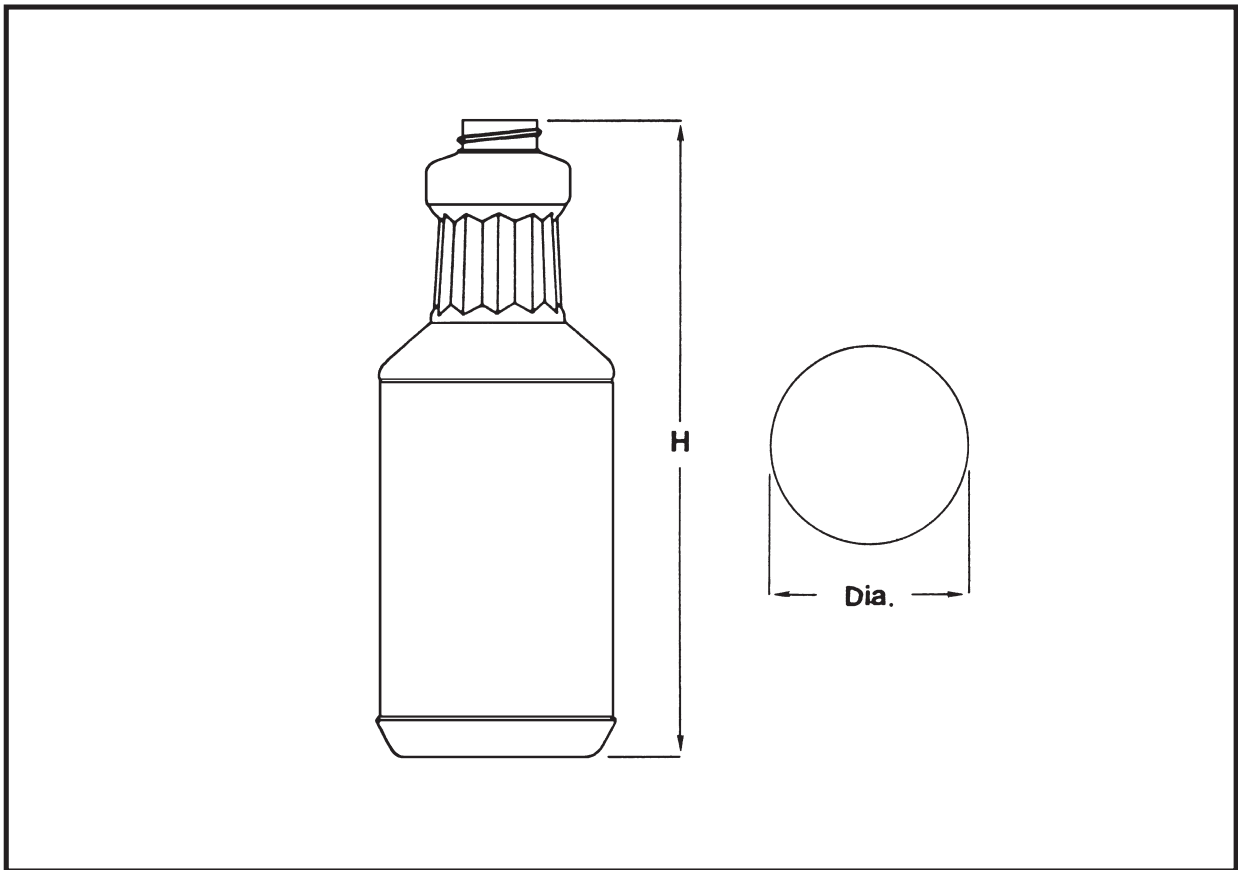

#102 FLUTED CARAFES

CAPACITY	NECKS	MATERIAL	HEIGHT	DIAMETER
32 oz	28-400 Ramp	HDPE	9.59"	3.49"
32 oz	28-410	HDPE	9.87"	3.49"

Available with and without view striping.

FLUTED DECANTER

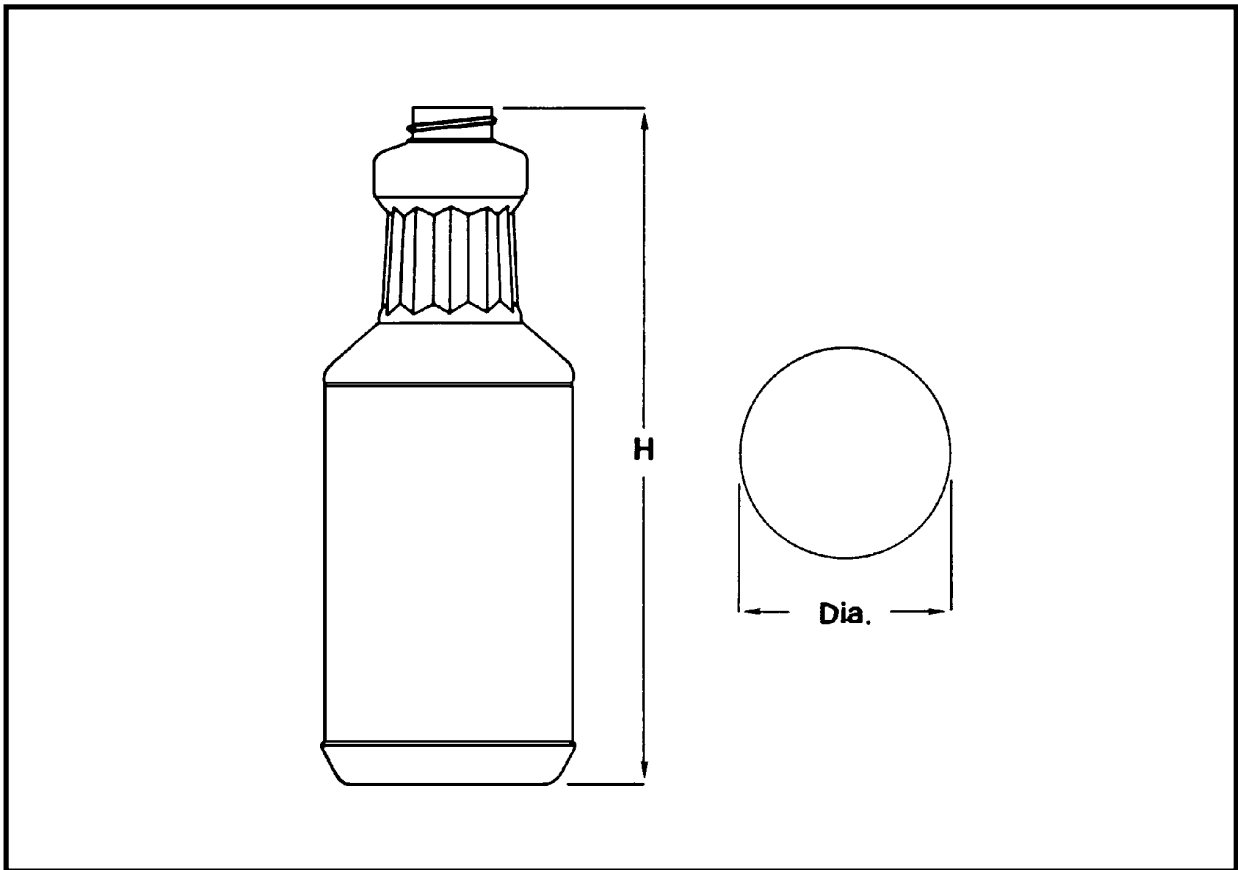

FLUTED DECANTER

CAPACITY	NECKS	MATERIAL	HEIGHT	DIAMETER
16 oz	28-400 .415" H	HDPE	7.59"	2.74"
16 oz	28-400 .460" H	HDPE	7.635"	2.74"
16 oz	28-410	HDPE	7.90"	2.74"
16 oz	38mm LT	HDPE	7.59"	2.74"
32 oz	28mm PS211	HDPE	9.88"	3.44"
32 oz	38-400	HDPE	9.88"	3.44"

Available with and without view striping

#710 BULB TOP ROUNDS

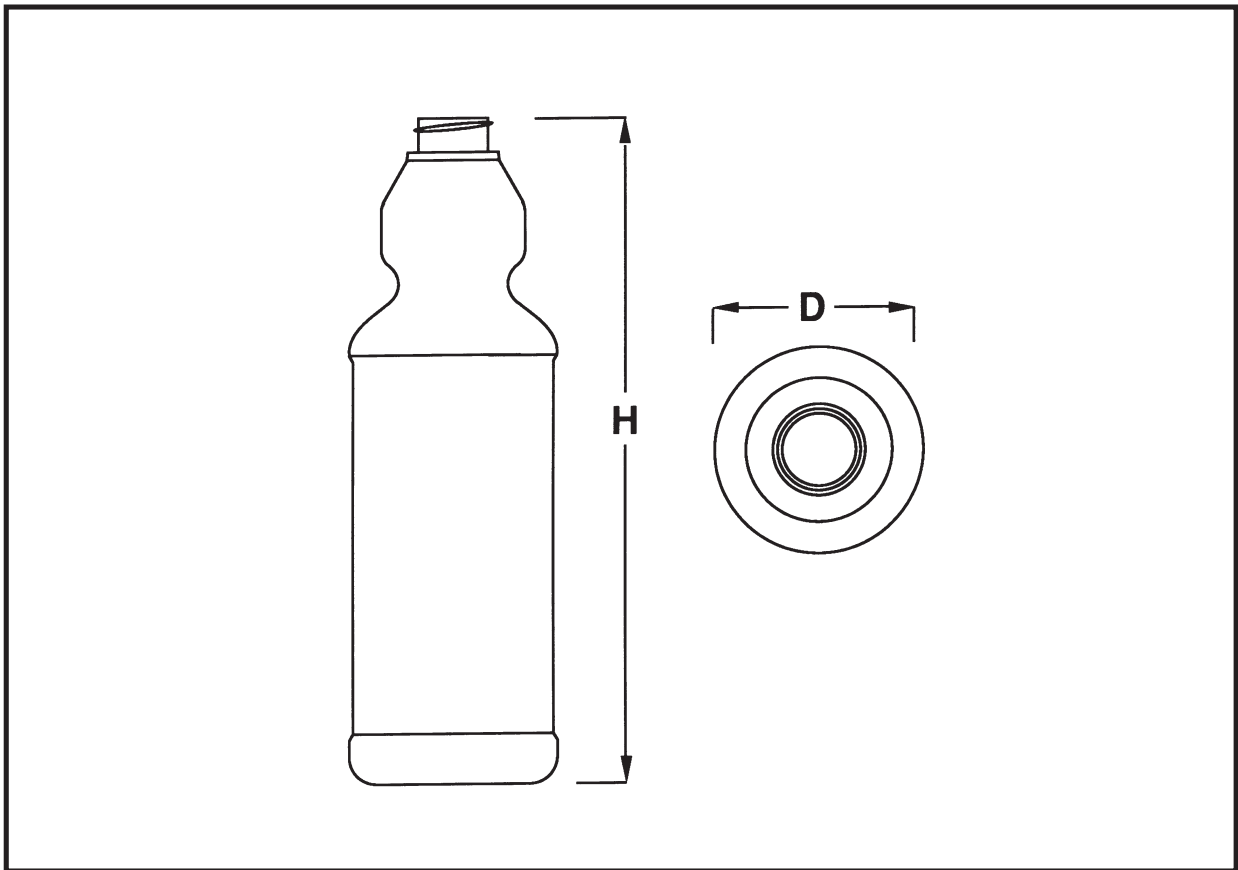

#710 BULB TOP ROUNDS

CAPACITY	NECKS	MATERIAL	HEIGHT	DIAMETER
32 oz	28-400sp	HDPE	9.84"	3.38"
32 oz	28-410	HDPE	10.13"	3.38"

BIG GRIPPER

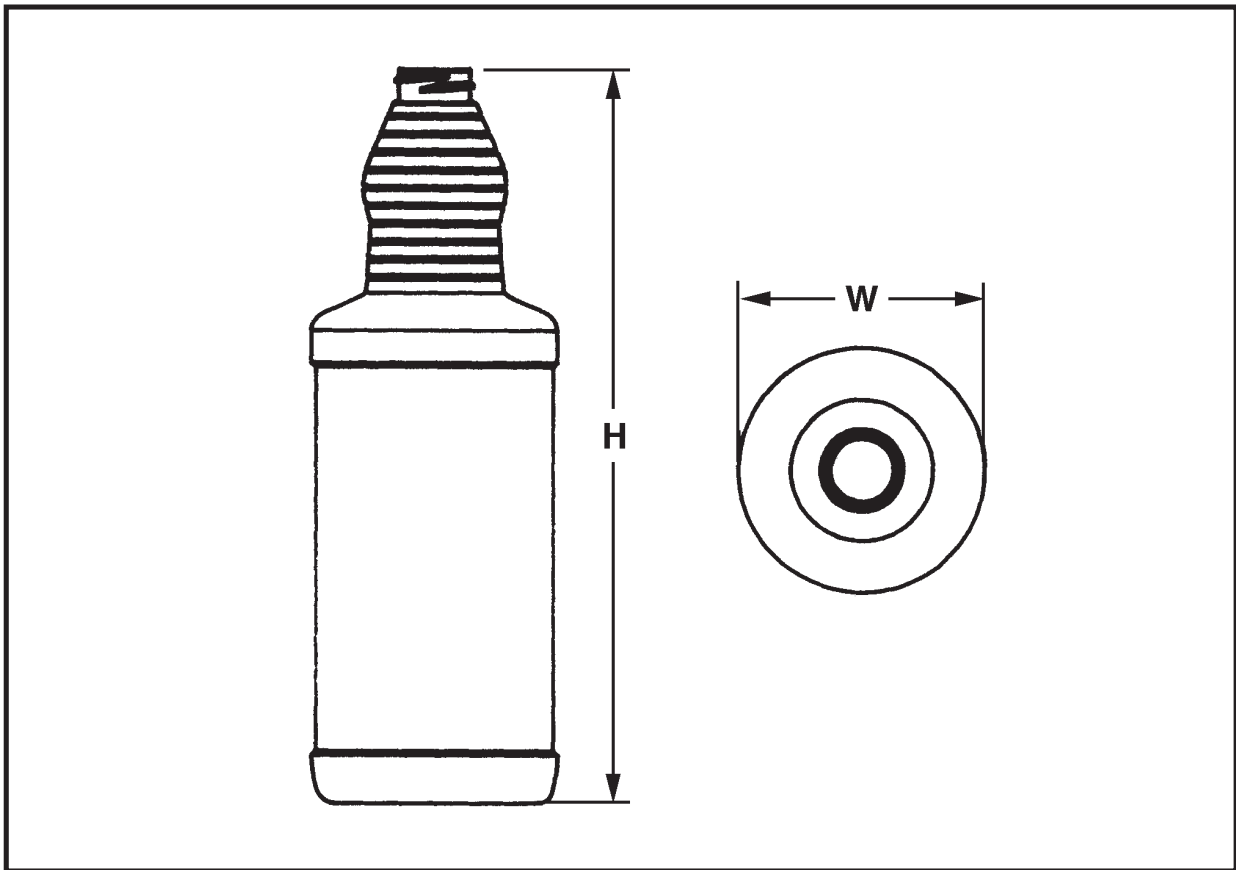

BIG GRIPPER

CAPACITY	NECKS	MATERIAL	HEIGHT	DIAMETER
32 oz / 1 L	28-400	HDPE	10.255"	3.42"
32 oz / 1 L	28mm PS211	HDPE	10.43"	3.42"

HANDLEWARE ROUNDS

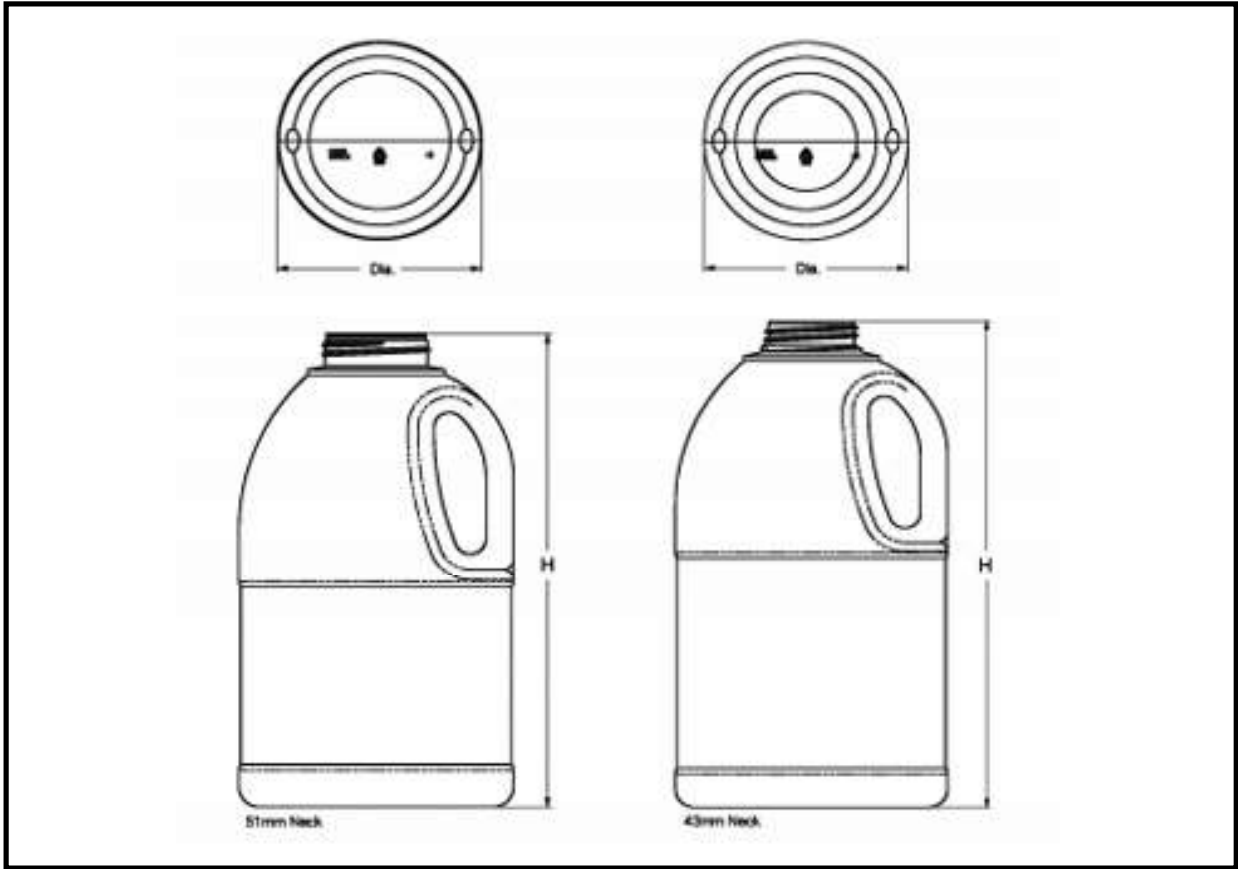

HANDLEWARE ROUNDS

CAPACITY	NECKS	MATERIAL	HEIGHT	DIAMETER
2 Liter	43mm Menshen*	HDPE	9.879"	5.00"
64 oz / 2 Liter	51mm Berry**	HDPE	8.929"	5.00"

*Works specifically with the Menshen 43mm one2dose closure

**Works specifically with the Berry Global 51mm detergent cap & spout

HIGH HANDLE HALF INDUSTRIAL ROUND

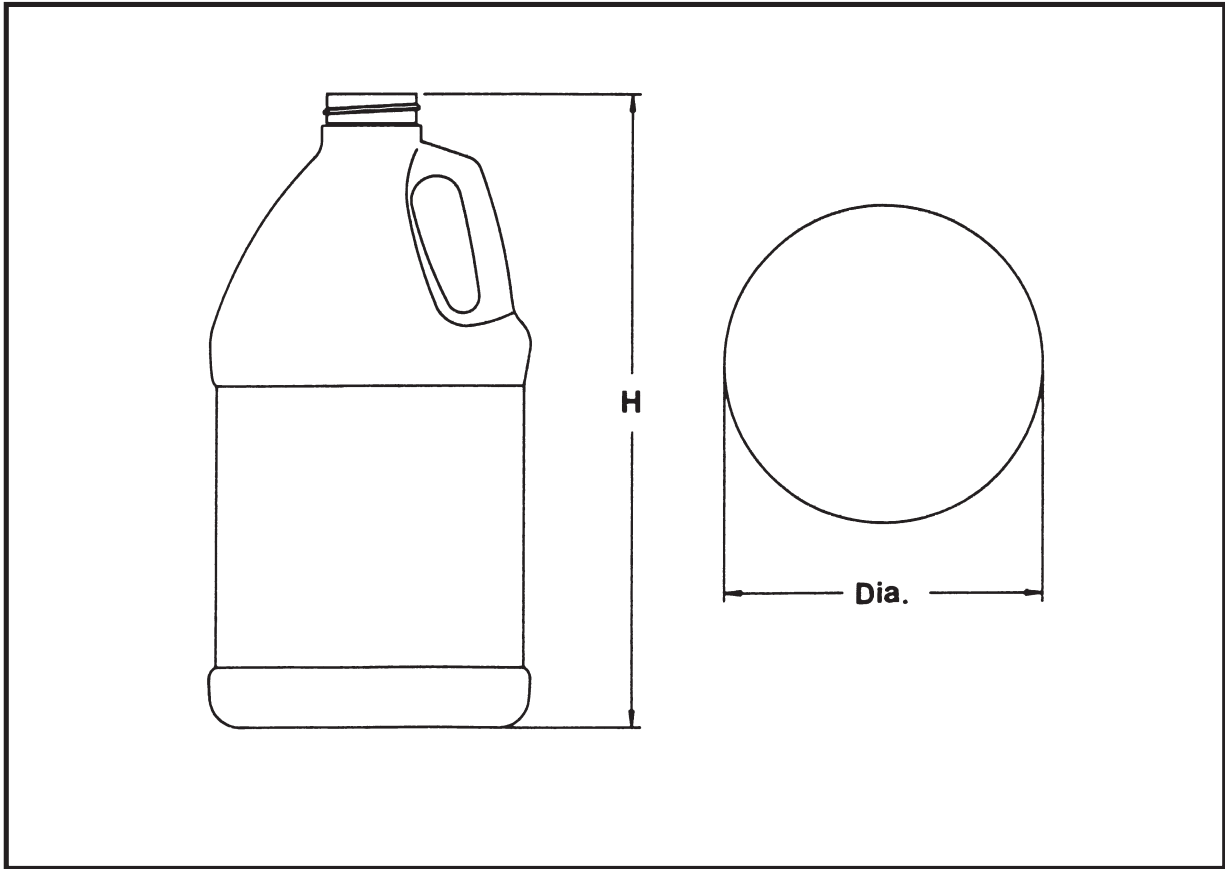

HIGH HANDLE HALF INDUSTRIAL ROUND

CAPACITY	NECKS	MATERIAL	HEIGHT	DIAMETER
64 oz	38-400	HDPE	9.68"	4.88"

WIDE MOUTH PACKER ROUND

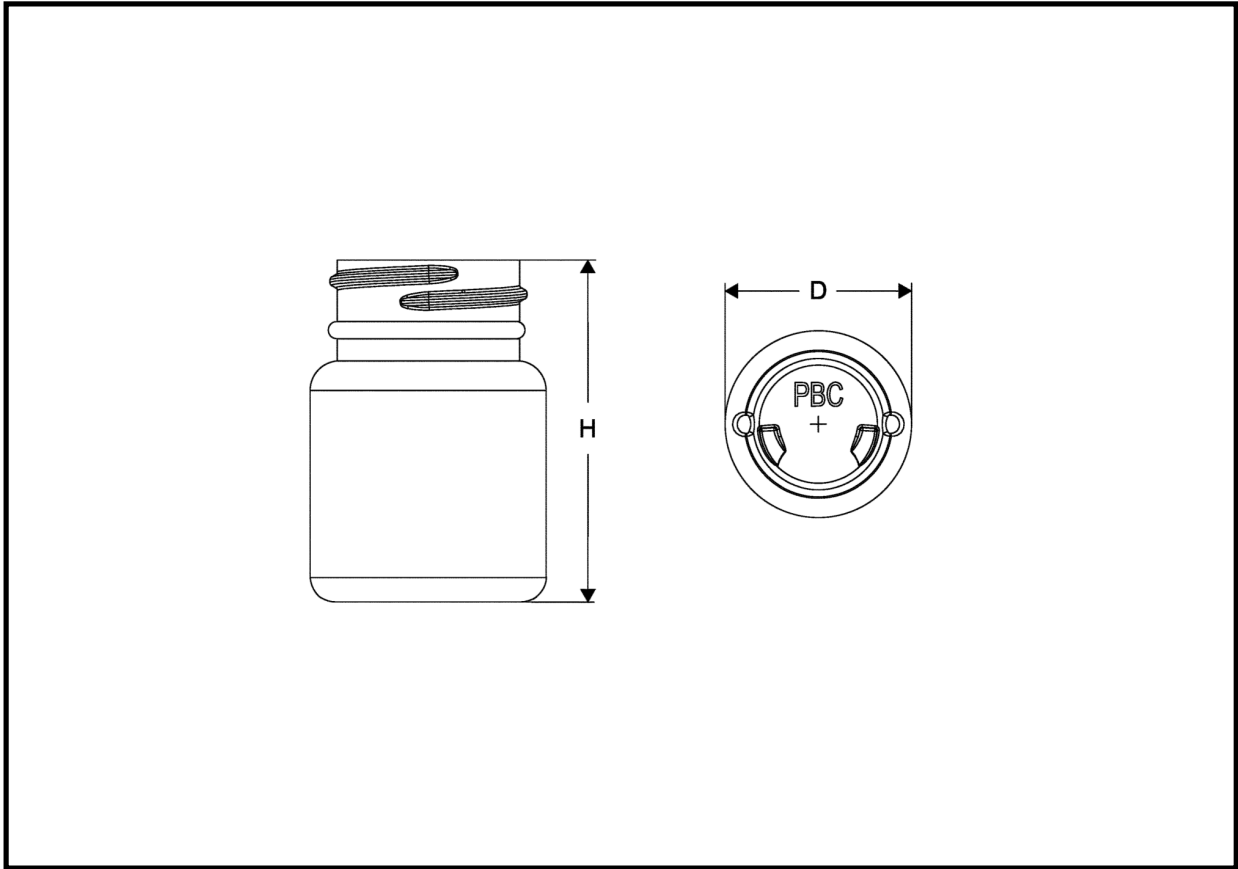

WIDE MOUTH PACKER ROUND

CAPACITY	NECKS	MATERIAL	HEIGHT	DIAMETER
1 oz	33-400	HDPE	2.17"	1.50"
30 cc	33-400	HDPE	2.17"	1.50"

TABLET ROUND

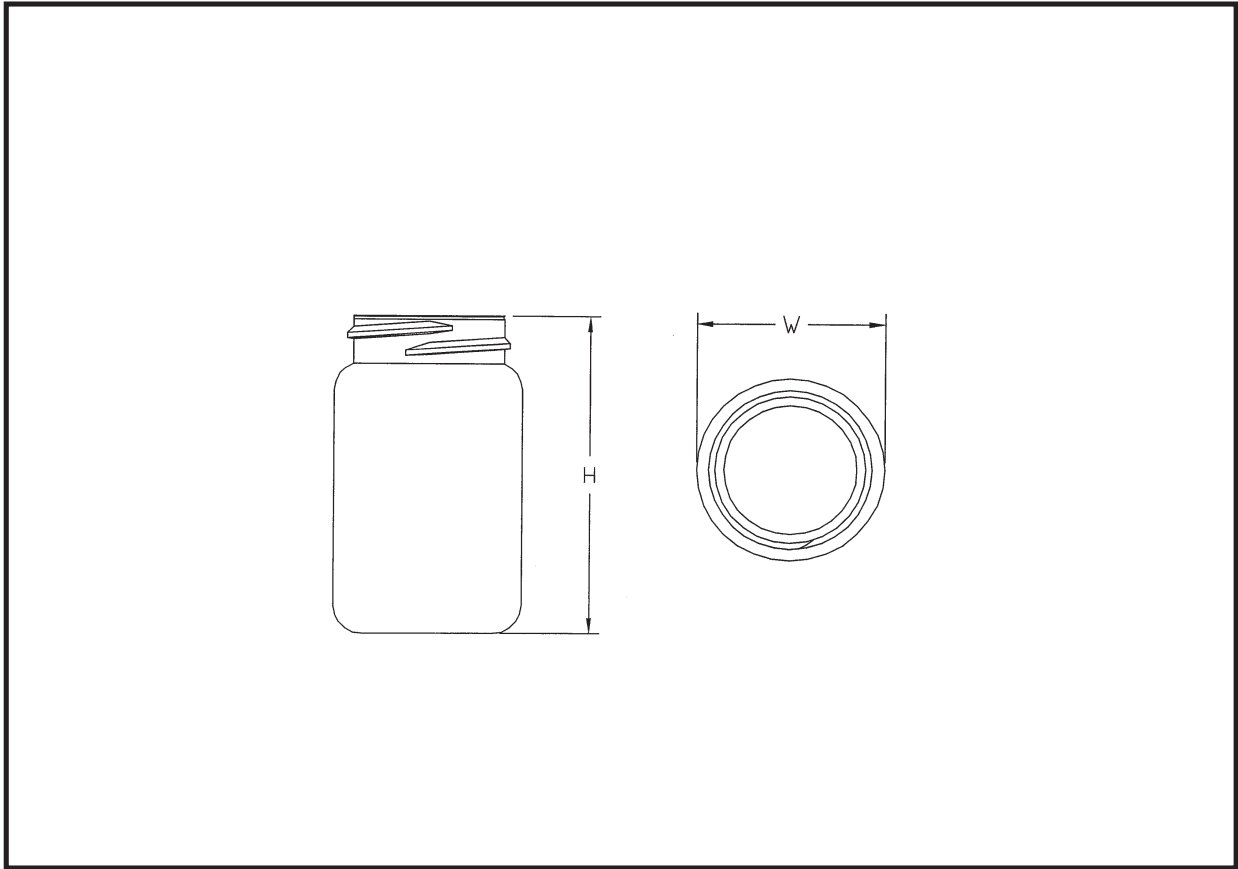

TABLET ROUND

CAPACITY	NECKS	MATERIAL	HEIGHT	DIAMETER
40/45 CC	33-400	HDPE	2.494"	1.44"

28mm finish can be developed as required.

TABLET ROUND

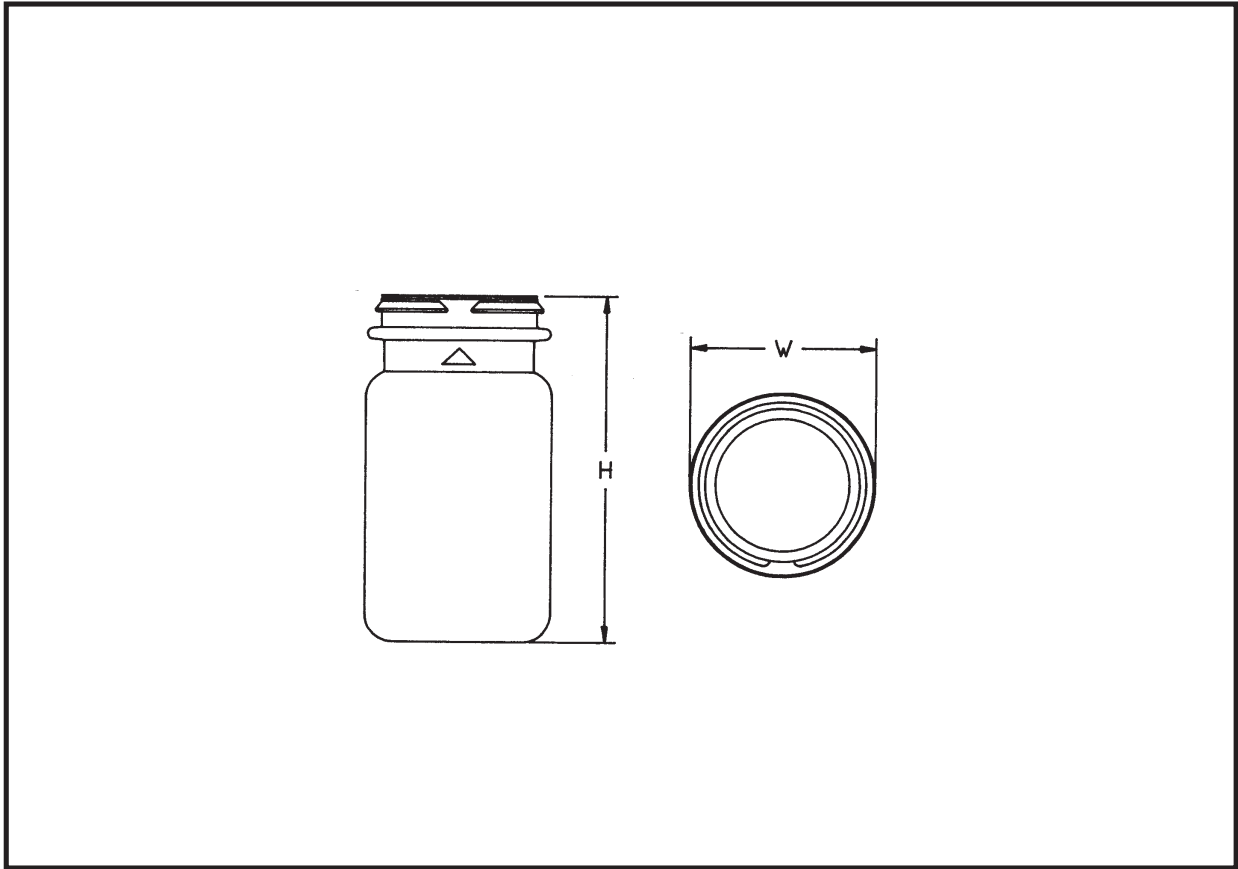

TABLET ROUND

CAPACITY	NECKS	MATERIAL	HEIGHT	DIAMETER
40/45 CC	33mm Line Up Arrow	HDPE	2.71"	1.44"

28mm finish can be developed as required.

MODERN ROUNDS

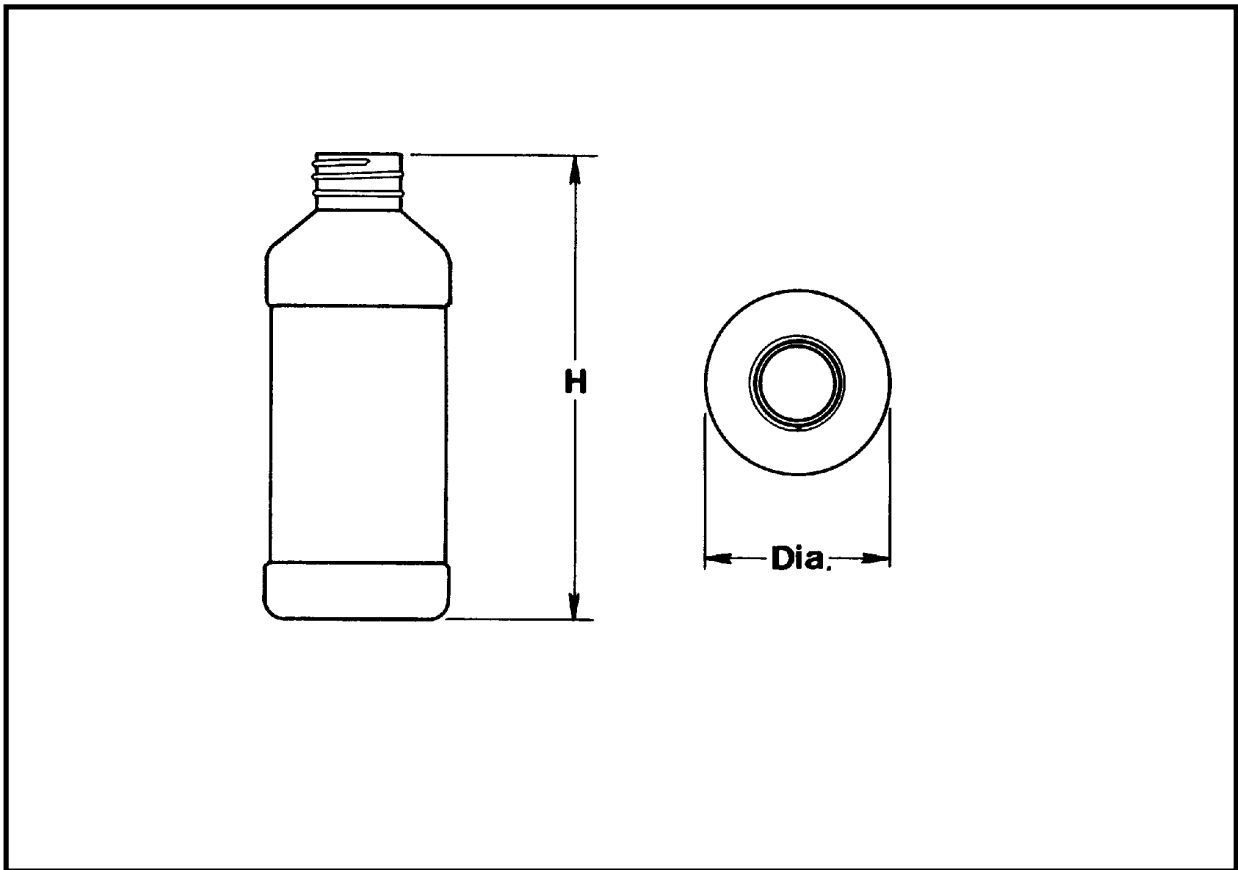

MODERN ROUNDS

CAPACITY	NECKS	MATERIAL	HEIGHT	DIAMETER
4 oz	24-410	HDPE	4.66"	1.75"
4 oz	28-410	HDPE	4.64"	1.75"
8 oz	28-400	HDPE	5.46"	2.24"
8 oz	28-410	HDPE	5.72"	2.24"

Available with and without view striping

MODERN ROUNDS

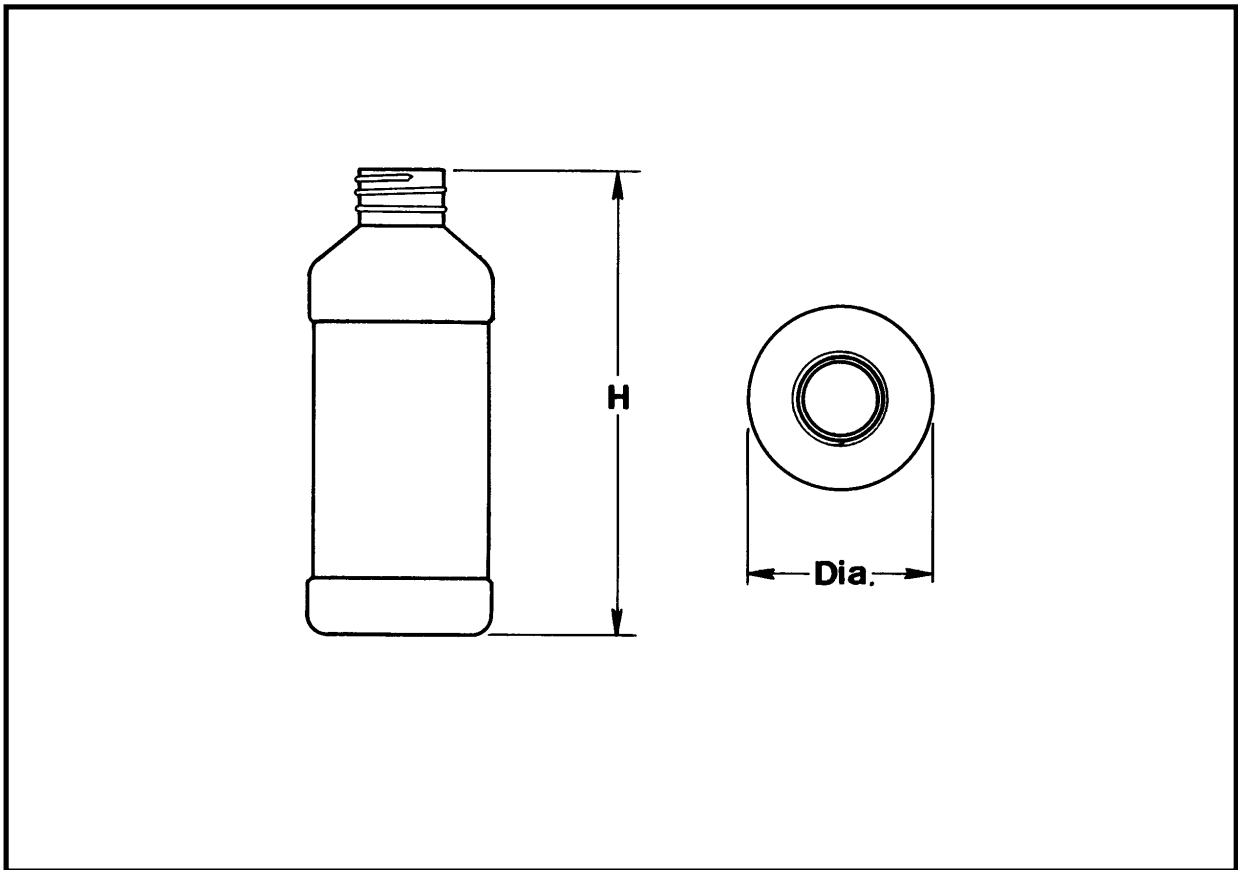

MODERN ROUNDS

CAPACITY	NECKS	MATERIAL	HEIGHT	DIAMETER
16 oz	28-410	HDPE	6.90"	2.78"
16 oz	28mm TE	HDPE	6.90"	2.78"
525 ml	28-410	HDPE	7.10"	2.78"

Available with and without view striping

THE CLASSIC MODERN ROUND

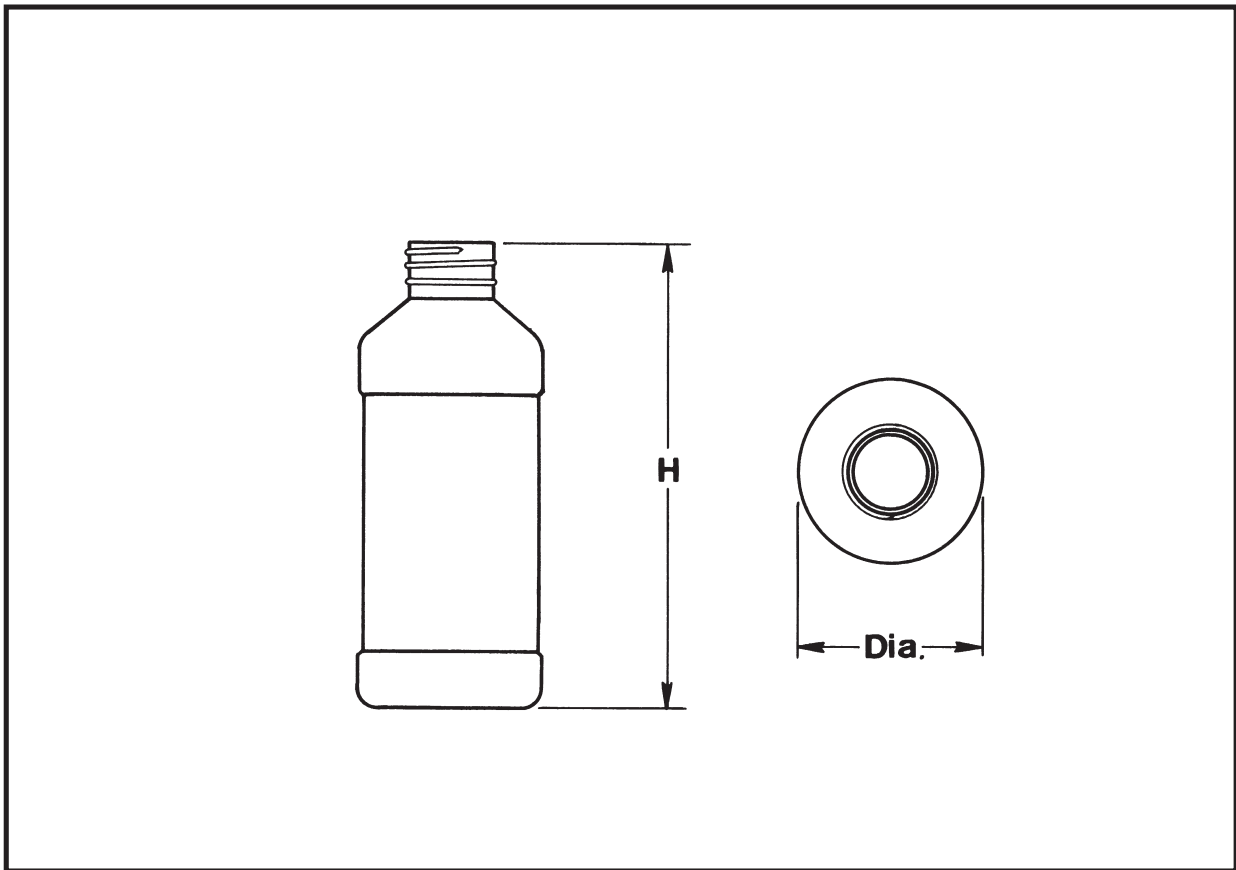

THE CLASSIC MODERN ROUND

CAPACITY	NECKS	MATERIAL	HEIGHT	DIAMETER
16 oz	28-410	HDPE	6.86"	2.77"

MODERN ROUNDS

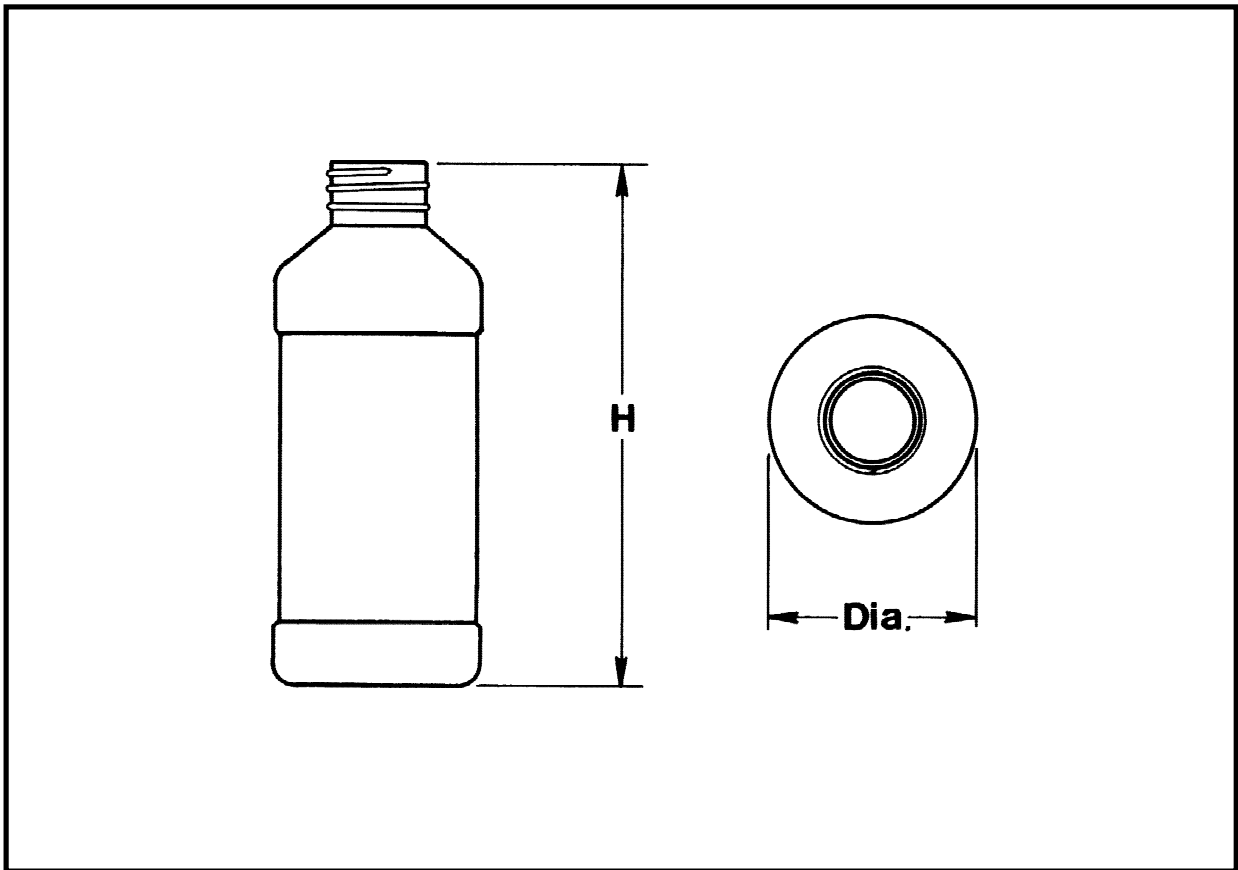

MODERN ROUNDS

CAPACITY	NECKS	MATERIAL	HEIGHT	DIAMETER
32 oz	28-410*	HDPE	8.525"	3.435"
32 oz	28-410	HDPE	8.86"	3.40"
32 oz	28mm HP2/HP3 Hose End**	HDPE	8.93"	3.435"
32 oz	38-400	HDPE	8.80"	3.40"
1 Liter	28-410	HDPE	9.07"	3.40"
1 Liter	38-400	HDPE	9.05"	3.40"

*This neck finish is available with view striping.

**Only to be used with a WestRock/MWW/Calmar Hose End Ratcheted Closure.

HARBOUR ROUNDS

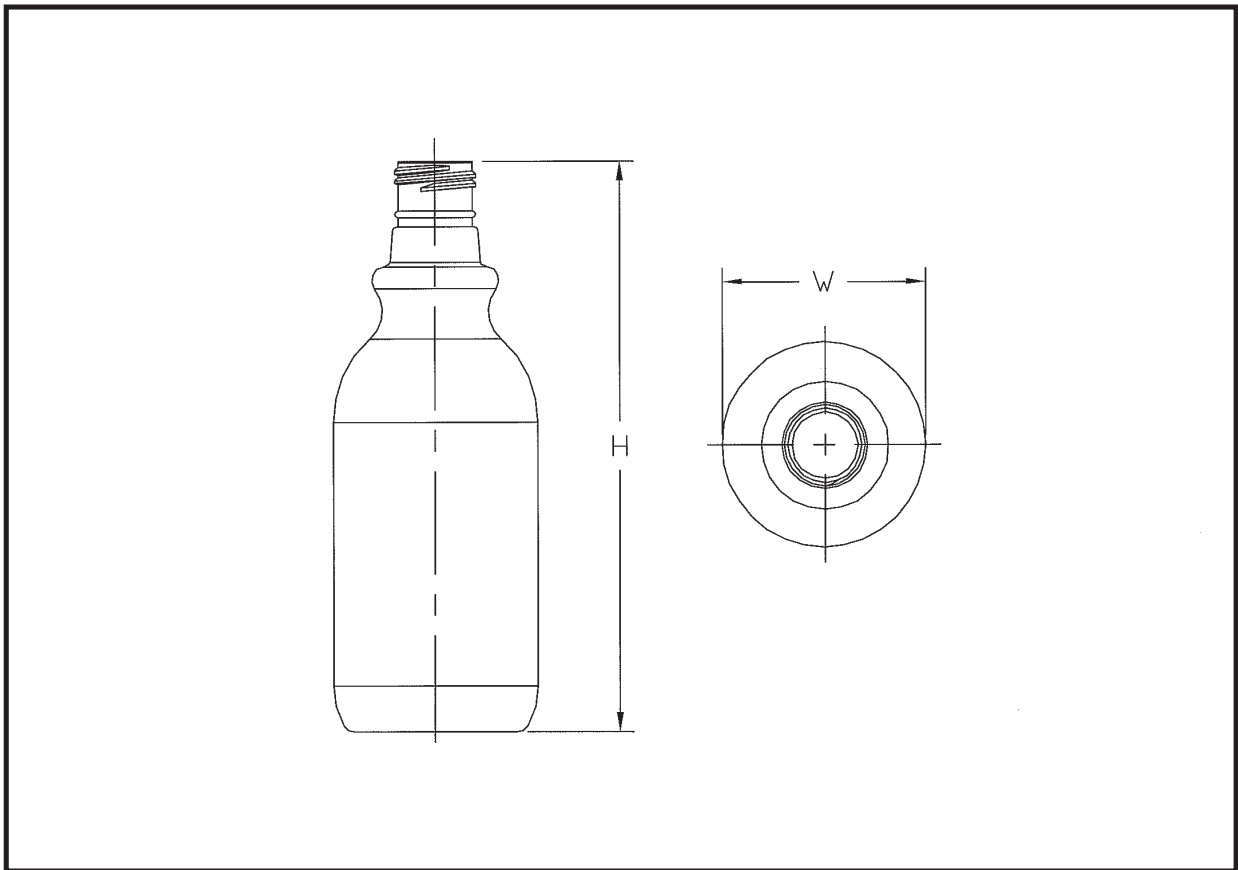

HARBOUR ROUNDS

CAPACITY	NECKS	MATERIAL	HEIGHT	DIAMETER
8 oz	28mm Jigger	PVC or PETG	6.295"	2.2"
16 oz	28mm Jigger	PVC or PETG	7.585"	2.74"

PANELED ROUND JAR

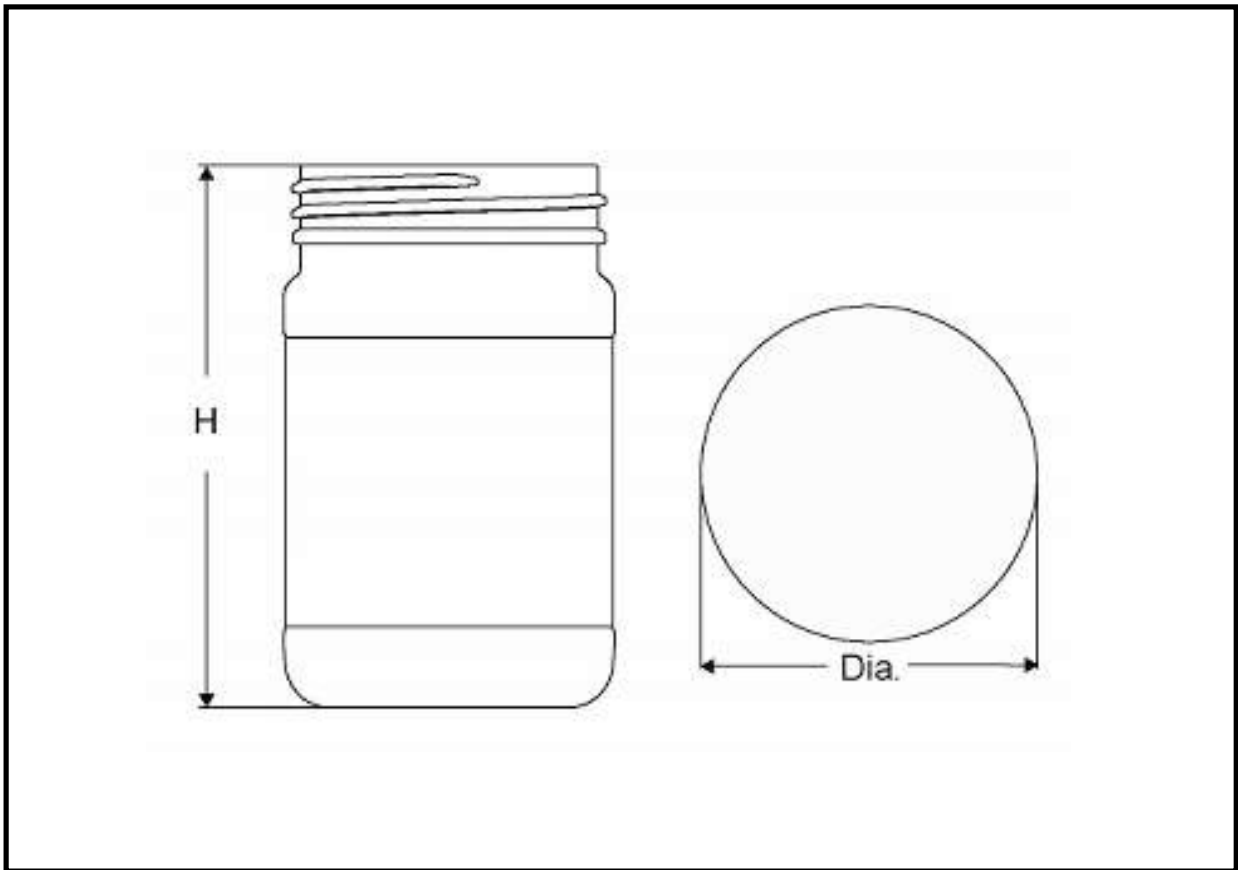

PANELED ROUND JAR

CAPACITY	NECKS	MATERIAL	HEIGHT	DIAMETER
6 oz	53-400	OPET	3.551"	2.177"

WIDE MOUTH JAR

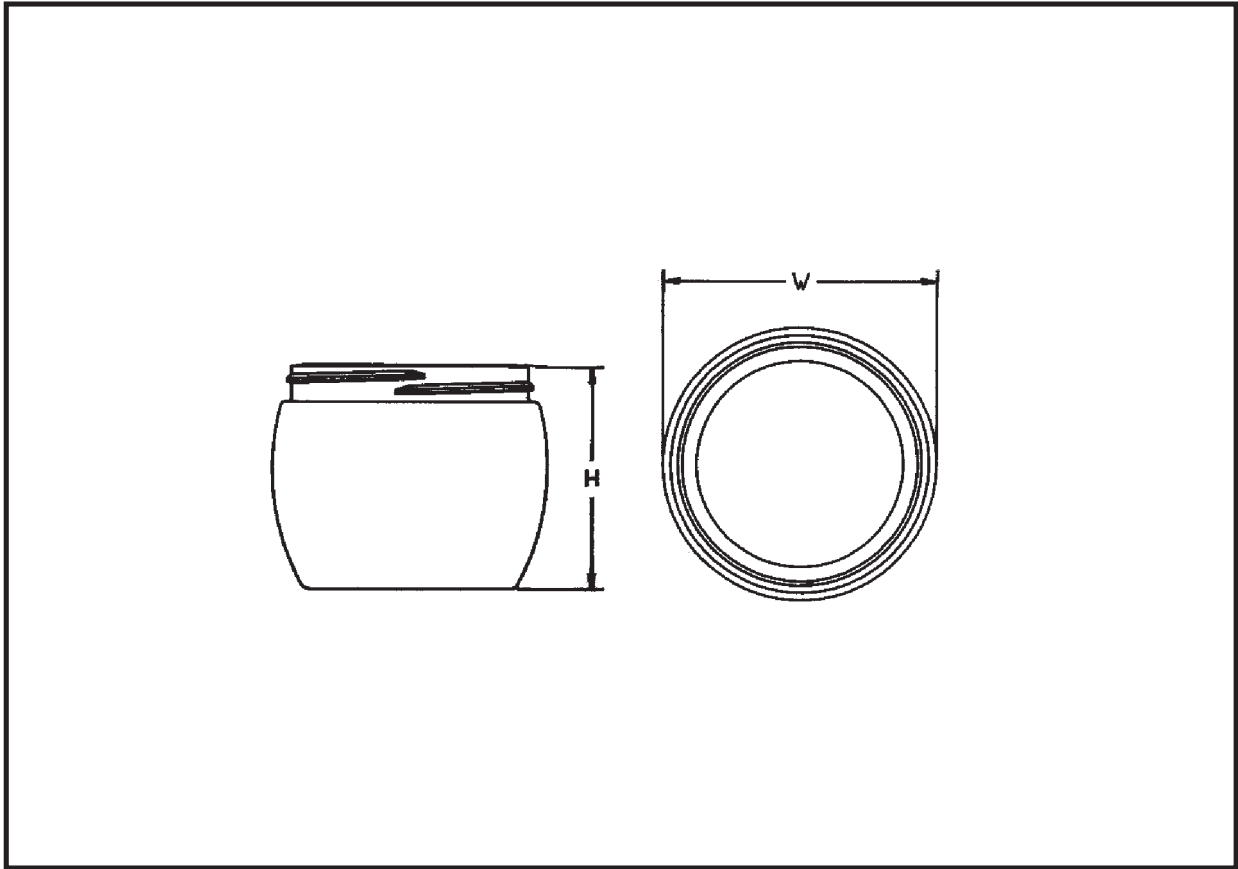

WIDE MOUTH JAR

CAPACITY	NECKS	MATERIAL	HEIGHT	DIAMETER
6 oz	70-400	HDPE	2.486"	3.050"

PACKER ROUND

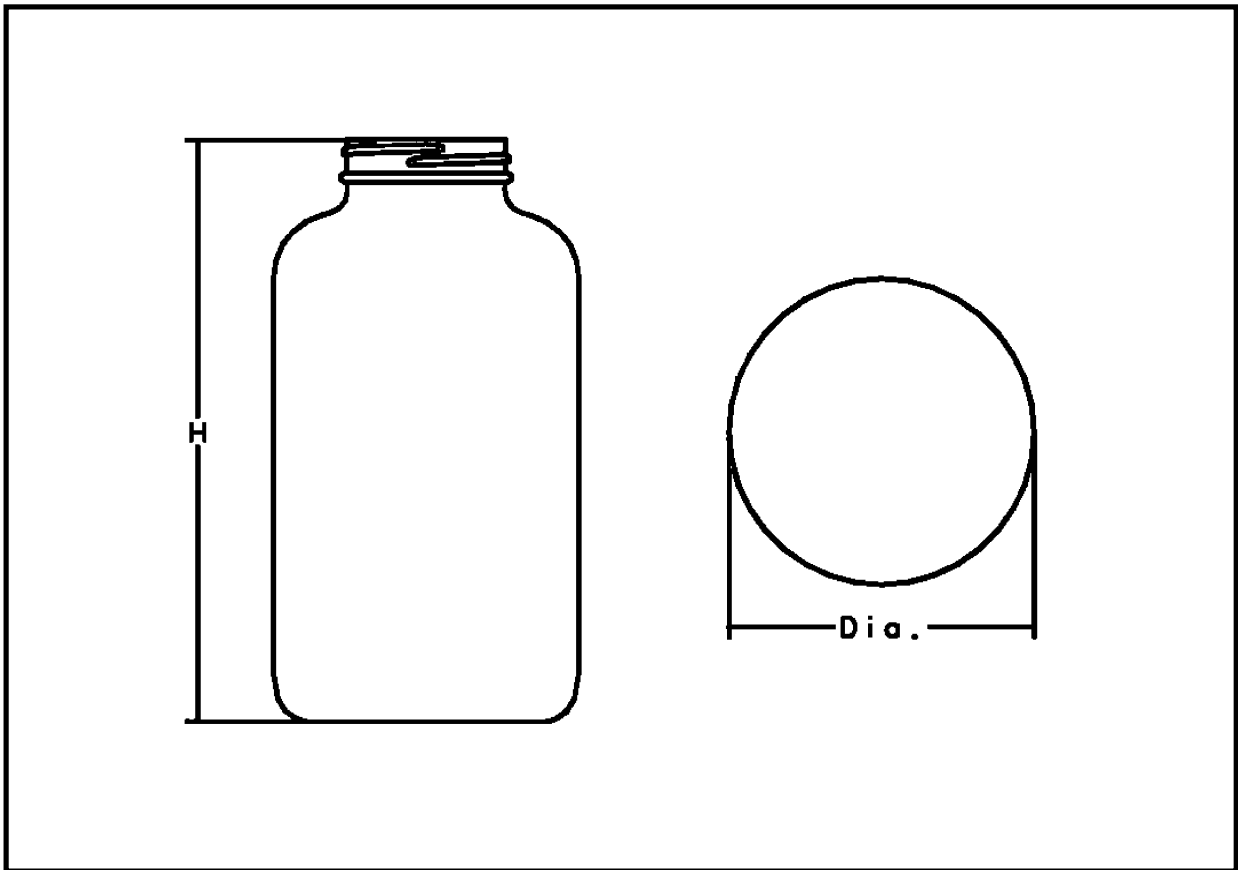

PACKER ROUND

CAPACITY	NECKS	MATERIAL	HEIGHT	DIAMETER
32 oz / 1 Liter	53-400	HDPE	7.14"	3.75"

MODIFIED ROUND

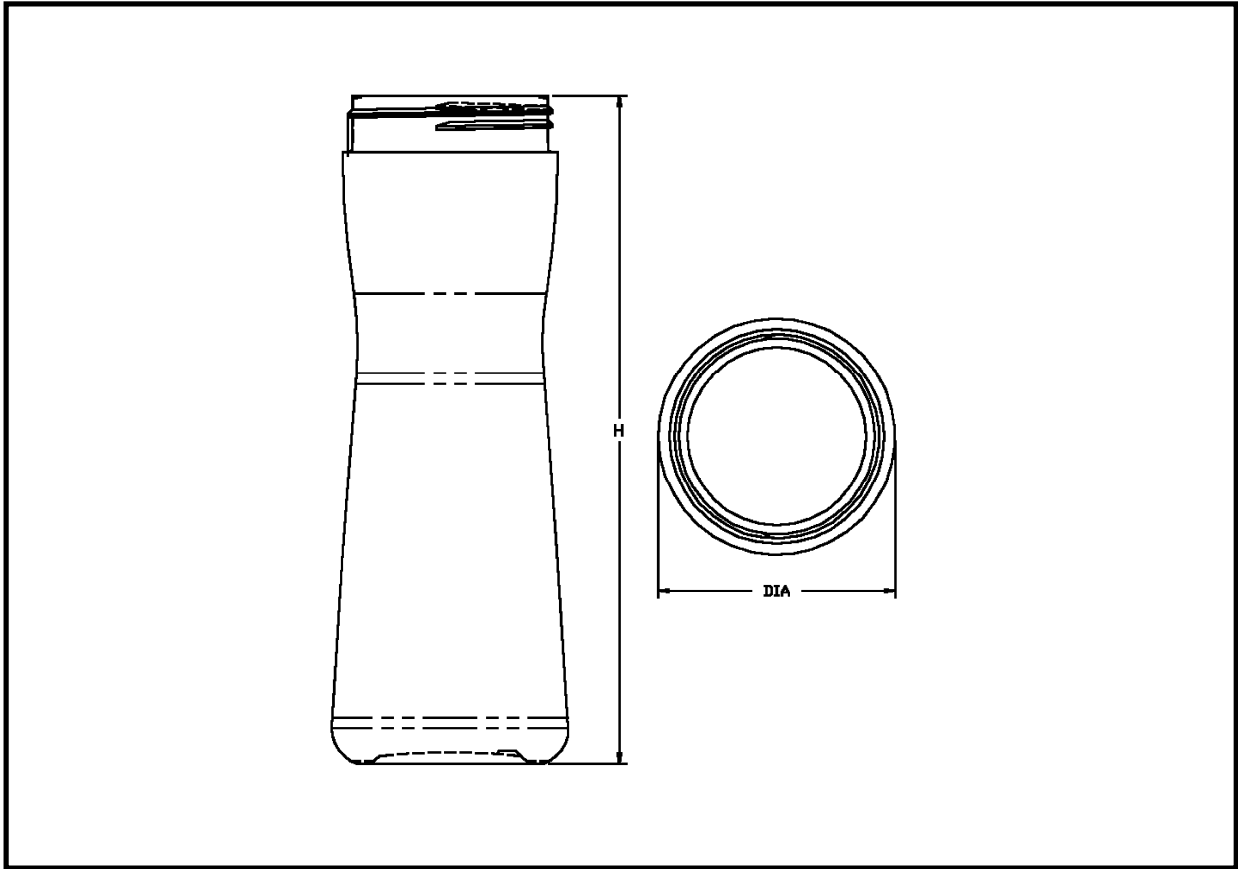

MODIFIED ROUND

CAPACITY	NECKS	MATERIAL	HEIGHT	DIAMETER
16 oz / 500 ml	63-485	HDPE	7.965"	2.819"

This neck is built to accommodate a Weatherchem dispensing closure.

MODIFIED ROUND

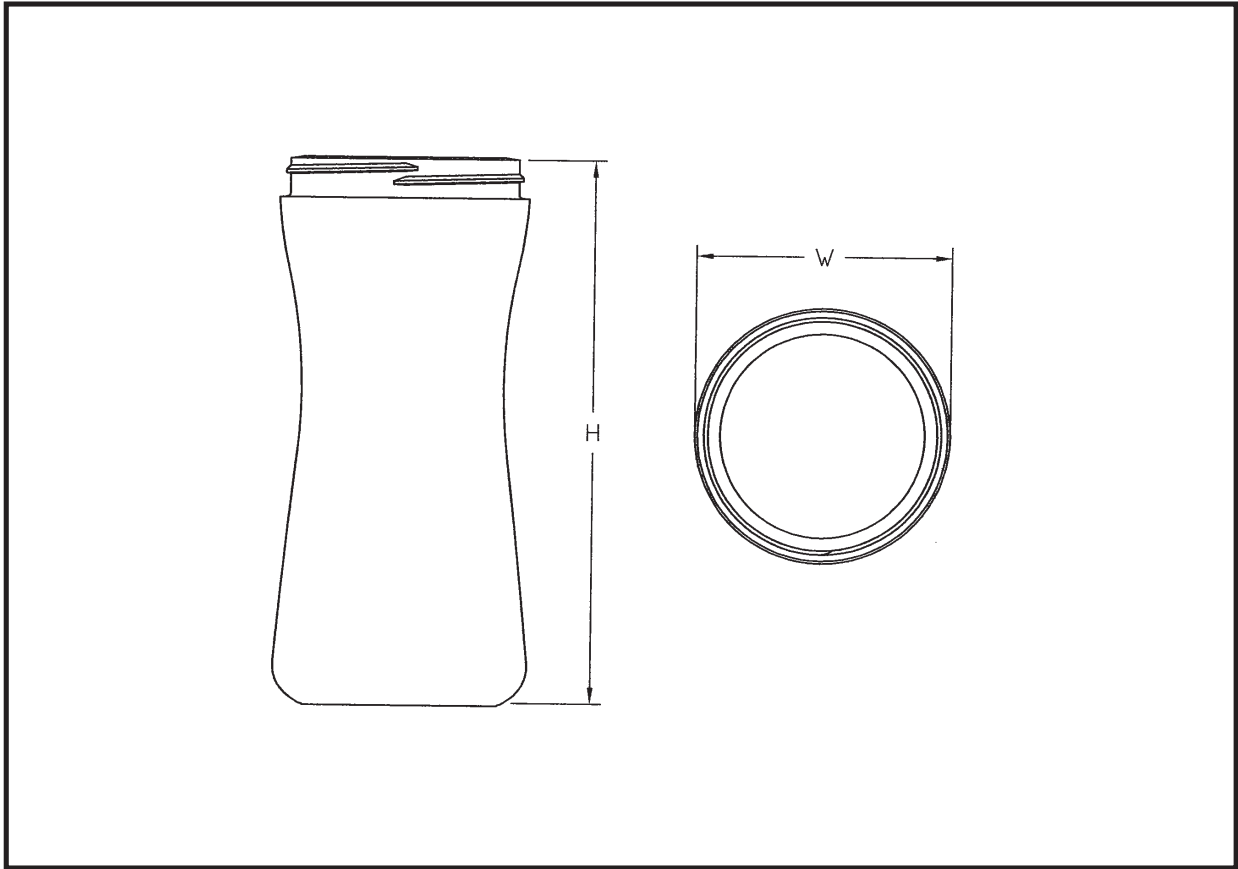

MODIFIED ROUND

CAPACITY	NECKS	MATERIAL	HEIGHT	DIAMETER
34 oz	89-400	HDPE	8.00"	3.75"

Closures are available through Plastic Bottle Corporation.

ROUND CANISTERS WITH LIDS

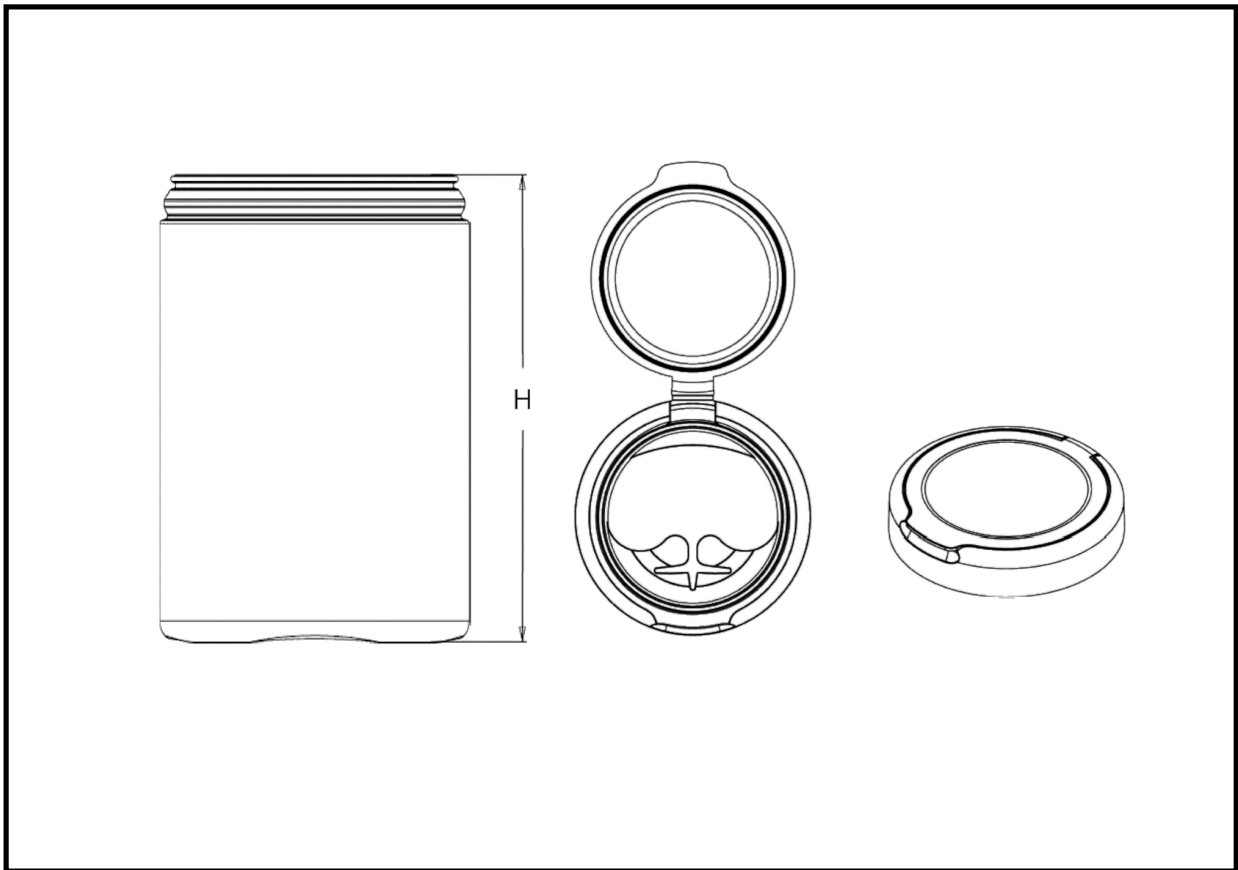

ROUND CANISTERS WITH LIDS

CAPACITY	NECKS	MATERIAL	HEIGHT	DIAMETER
34 oz	81mm Snap On Finish	HDPE	8.25"	3.31"
56 oz	105mm Snap On Finish	HDPE	8.25"	4.25"

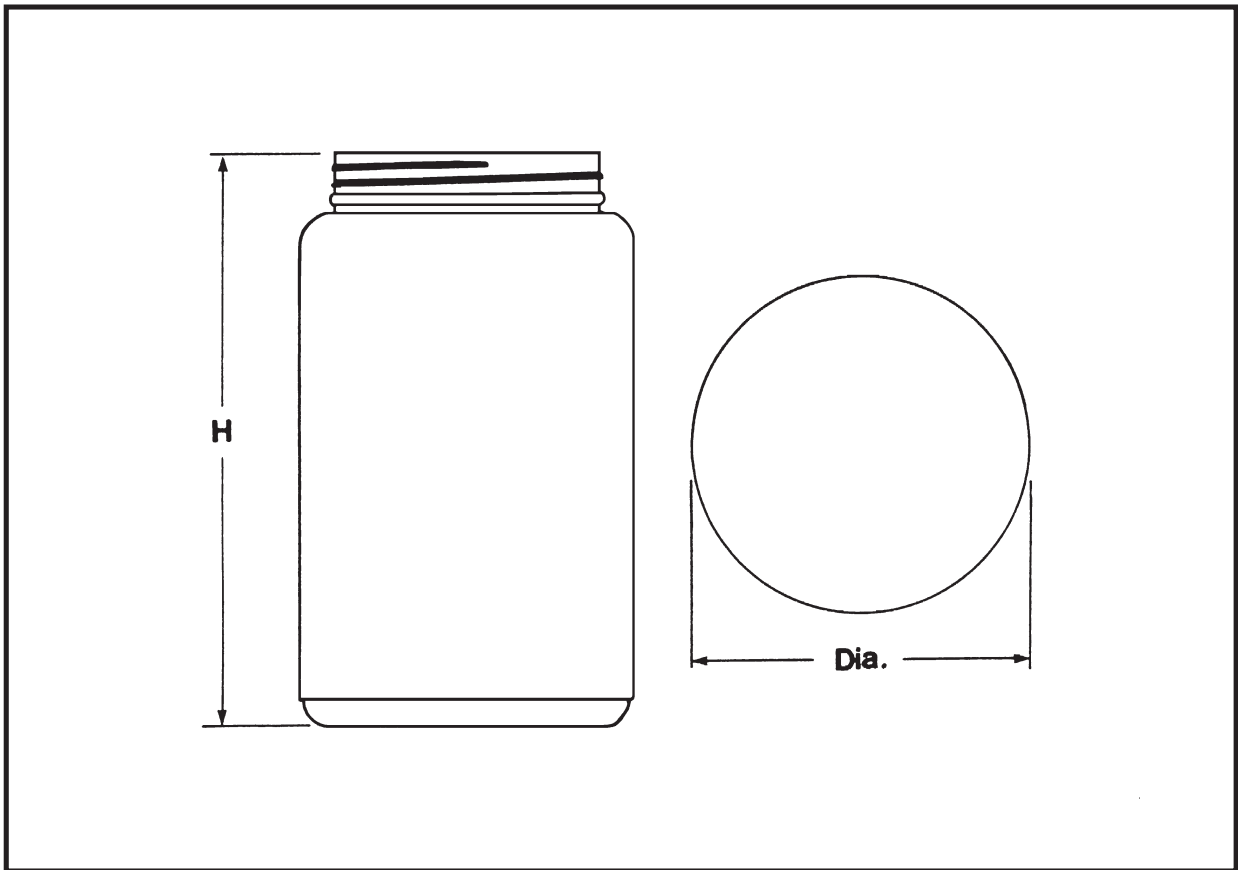
WIDE MOUTH ROUND**WIDE MOUTH ROUND**

CAPACITY	NECKS	MATERIAL	HEIGHT	DIAMETER
75 oz/2250 cc	100-400	HDPE	8.50"	4.90"



CYLINDERS

Where great ideas take shape.

STRAIGHT SIDED CYLINDERS

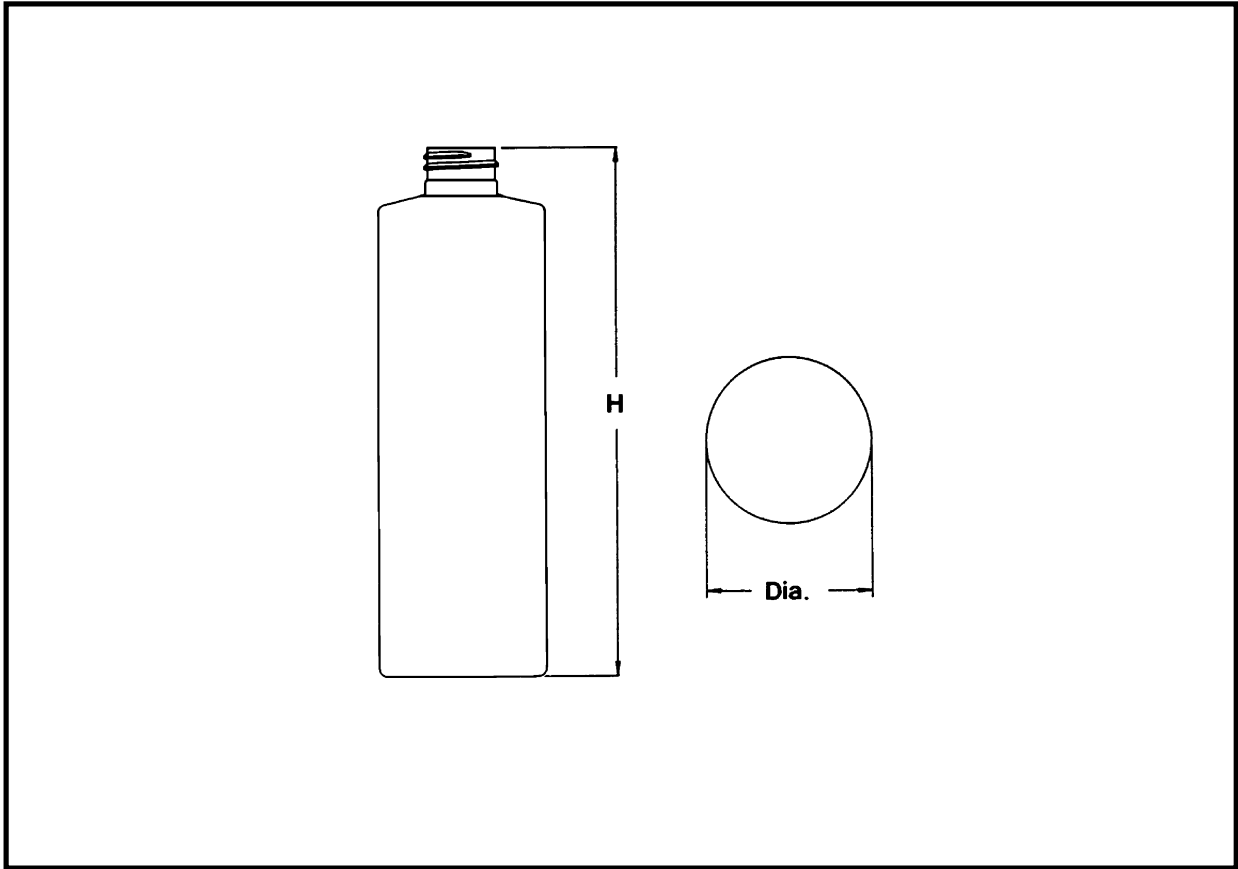

STRAIGHT SIDED CYLINDERS

CAPACITY	NECKS	MATERIAL	HEIGHT	DIAMETER
1 oz	20-410	PVC or PETG	2.789"	1.18"
1 oz	24-410	PVC or PETG	2.82"	1.18"
4 oz	24-400	HDPE	4.48"	1.65"
4 oz	24-410	HDPE	4.83"	1.65"
4 oz	24 mm Dab-O-Matic	HDPE	4.56"	1.65"

STRAIGHT SIDED CYLINDERS

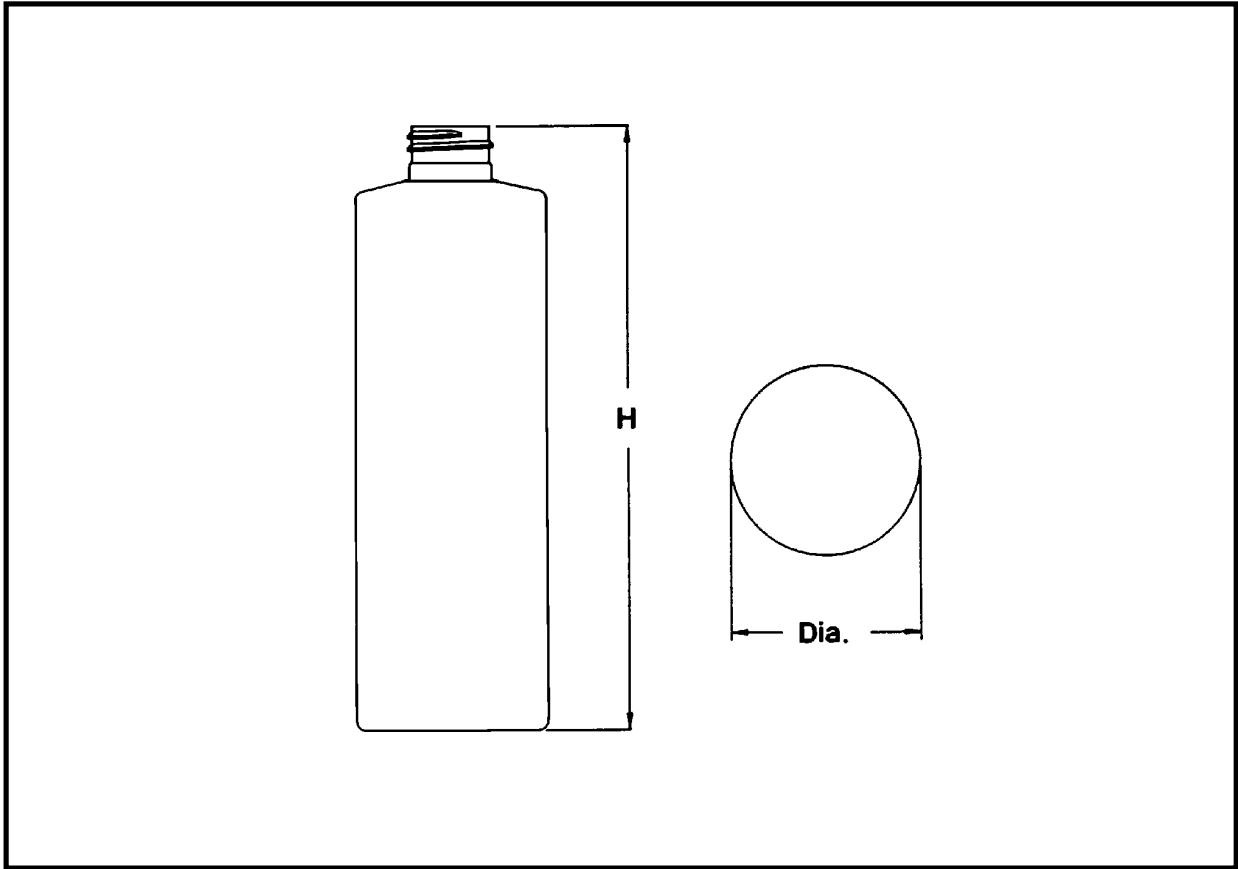

STRAIGHT SIDED CYLINDERS

CAPACITY	NECKS	MATERIAL	HEIGHT	DIAMETER
8 oz	24-410	HDPE	6.09"	2.10"
8 oz*	24-410	HDPE	6.14"	1.99"
8 oz*	24-415	HDPE	6.514"	1.99"
8 oz	38-400	HDPE	5.77"	2.10"
8 oz*	38-400	HDPE	5.832"	1.99"
8 oz	24-410	PVC	6.31"	1.93"

*When the bottle is blown at 18 grams the capacity will hold 250ml.

TALL SLIM CYLINDERS

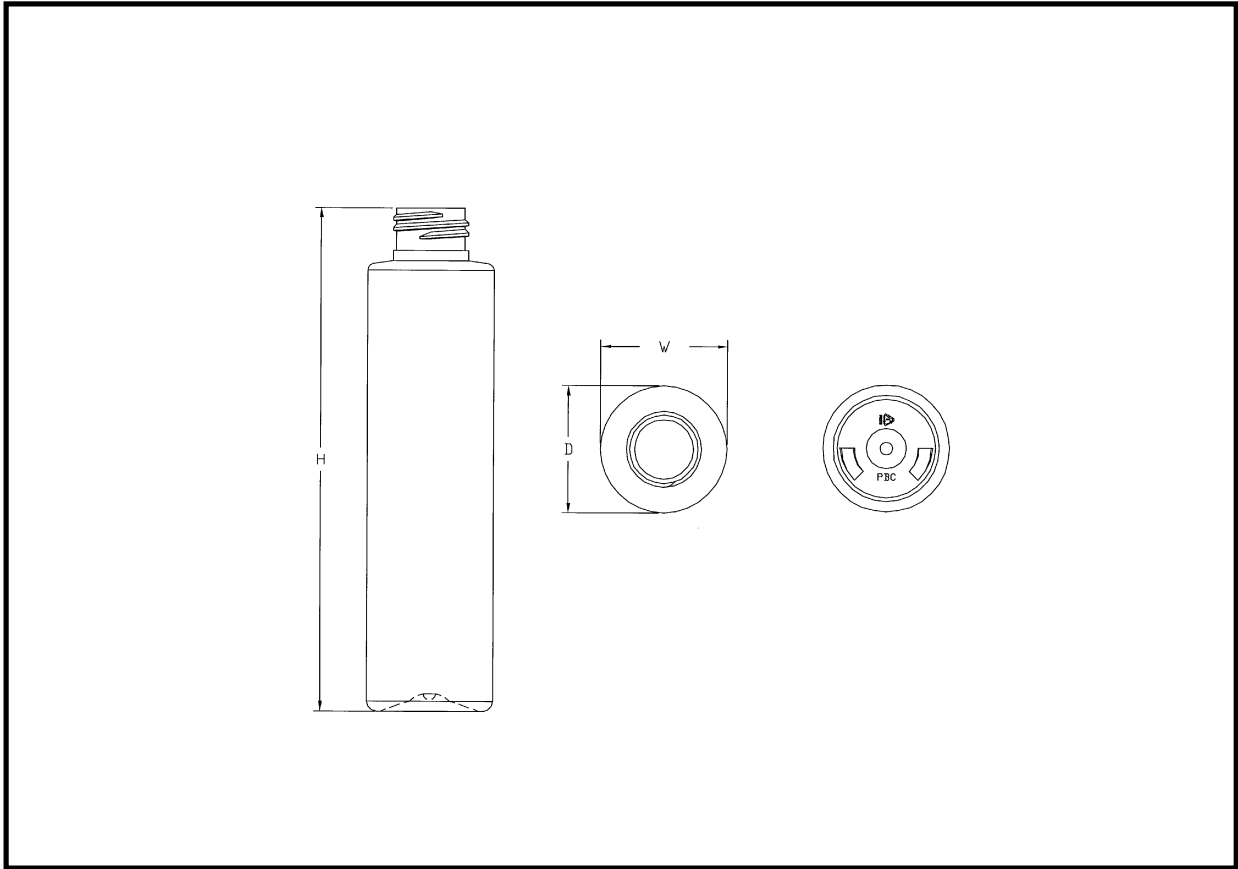

TALL SLIM CYLINDERS

CAPACITY	NECKS	MATERIAL	HEIGHT	DIAMETER
5 oz / 150 ml	24-410	OPET	5.032"	1.565"

STRAIGHT SIDED CYLINDER

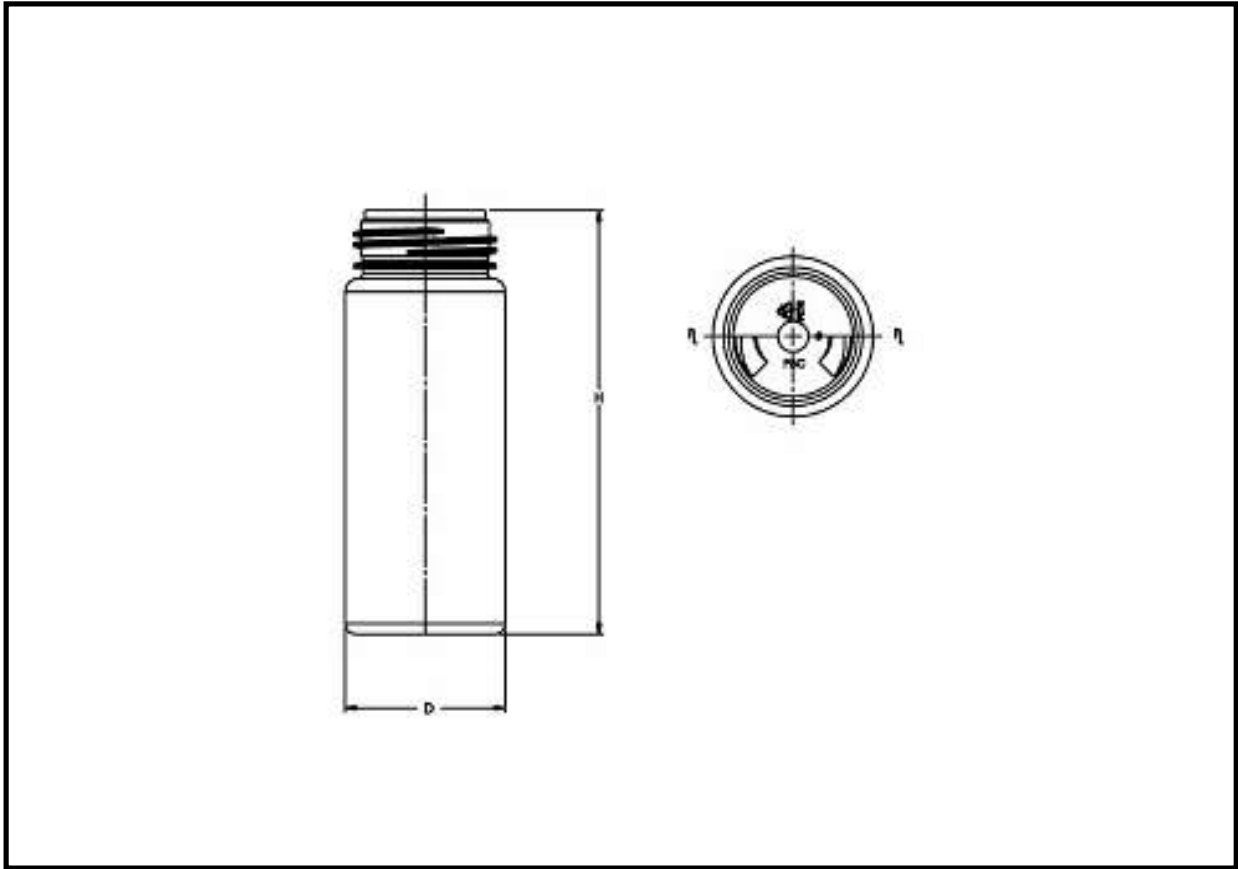

STRAIGHT SIDED CYLINDER

CAPACITY	NECKS	MATERIAL	HEIGHT	DIAMETER
140 ml	43mm Foamer	OPET	4.98"	1.88"

STRAIGHT SIDED CYLINDERS

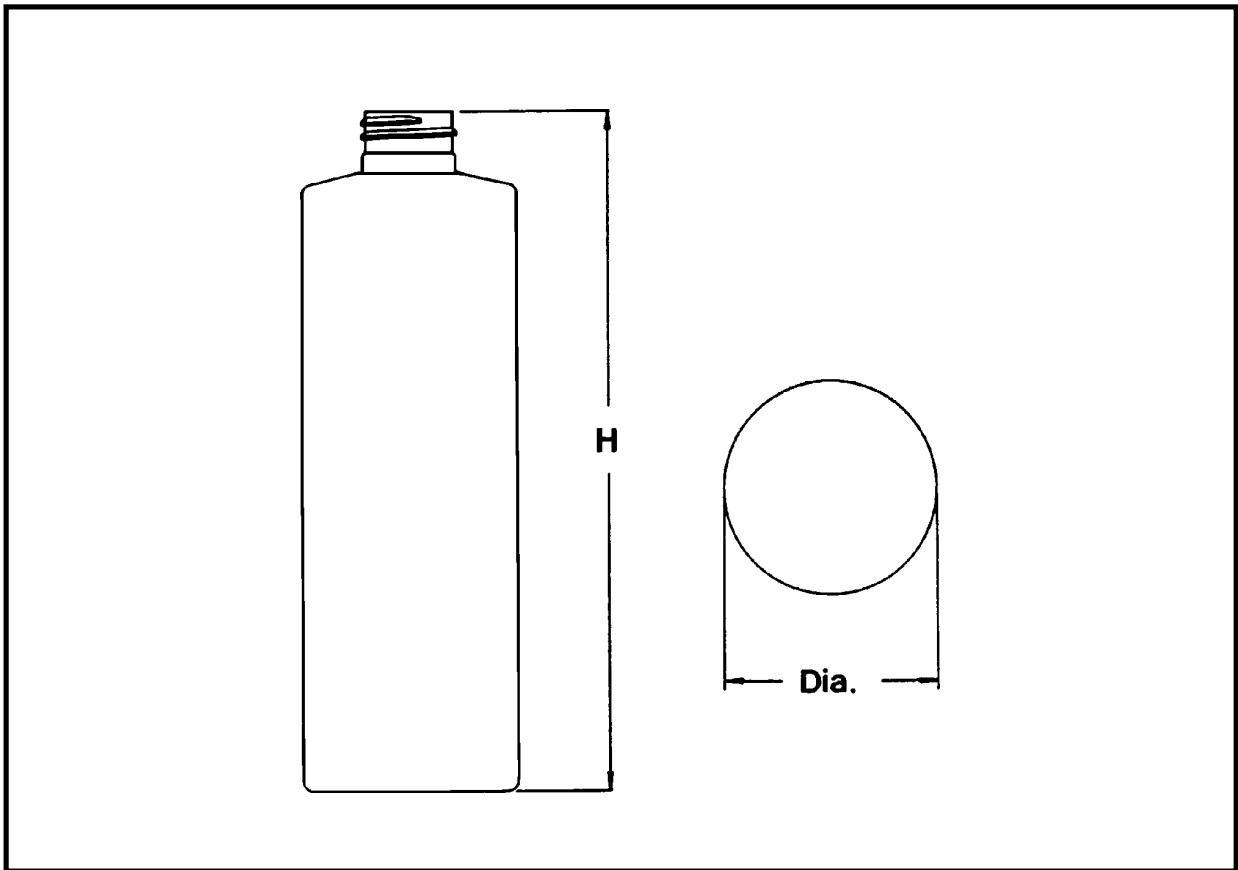

STRAIGHT SIDED CYLINDERS

CAPACITY	NECKS	MATERIAL	HEIGHT	DIAMETER
8 oz / 250 ml	24-410	OPET	6.136"	2.00"
8 oz / 250 ml	24-415	OPET	6.447"	2.00"
12 oz	24-410	PVC	7.08"	2.23"
15 oz	24-415	HDPE	8.07"	2.38"
16 oz / 500 ml	24-410sp	HDPE	7.75"	2.50"
16 oz / 500 ml	28-410sp	HDPE	7.75"	2.50"
16 oz / 500 ml	28-410	OPET	7.775"	2.45"
16 oz / 500 ml	28-415	OPET	8.15"	2.45"

STRAIGHT SIDED CYLINDERS

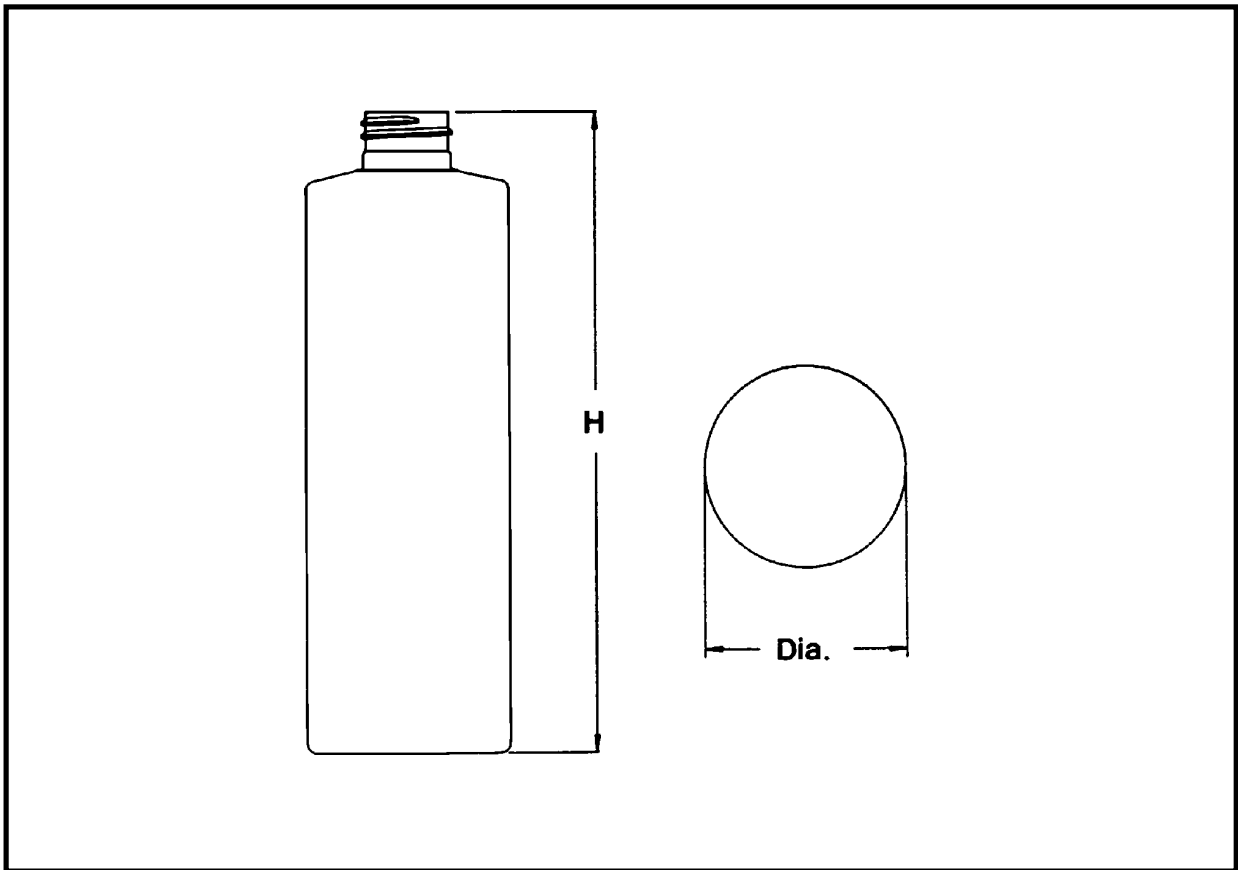

STRAIGHT SIDED CYLINDERS

CAPACITY	NECKS	MATERIAL	HEIGHT	DIAMETER
18 oz	24-410	HDPE	8.40"	2.50"
18 oz	38-400	HDPE	7.98"	2.50"

PANELED CYLINDER

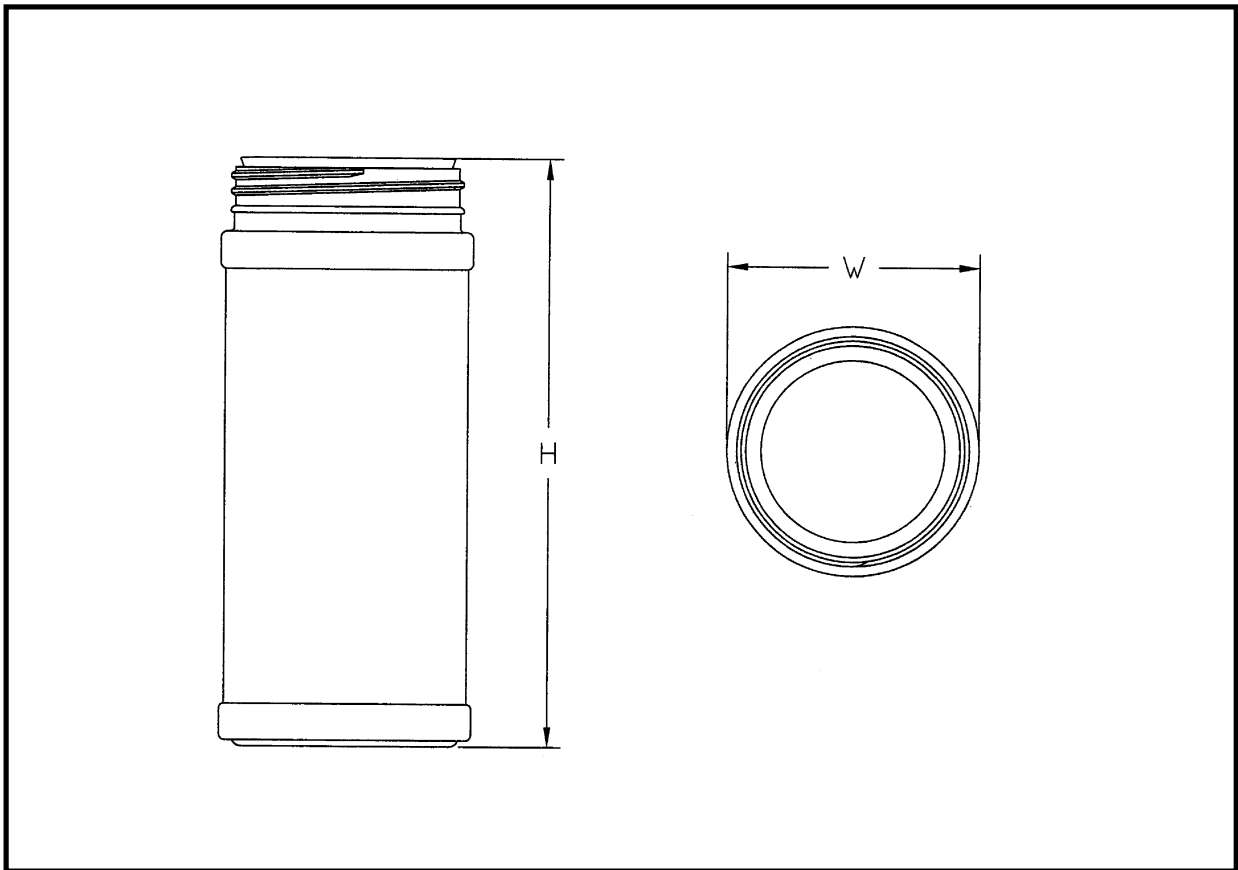

PANELED CYLINDER

CAPACITY	NECKS	MATERIAL	HEIGHT	DIAMETER
14 oz	63-485	HDPE	6.225"	2.65"

Works with a 63-485 Spice Cap and 63mm sifter fitment available from Plastic Bottle Corporation.

STRAIGHT SIDED CYLINDER

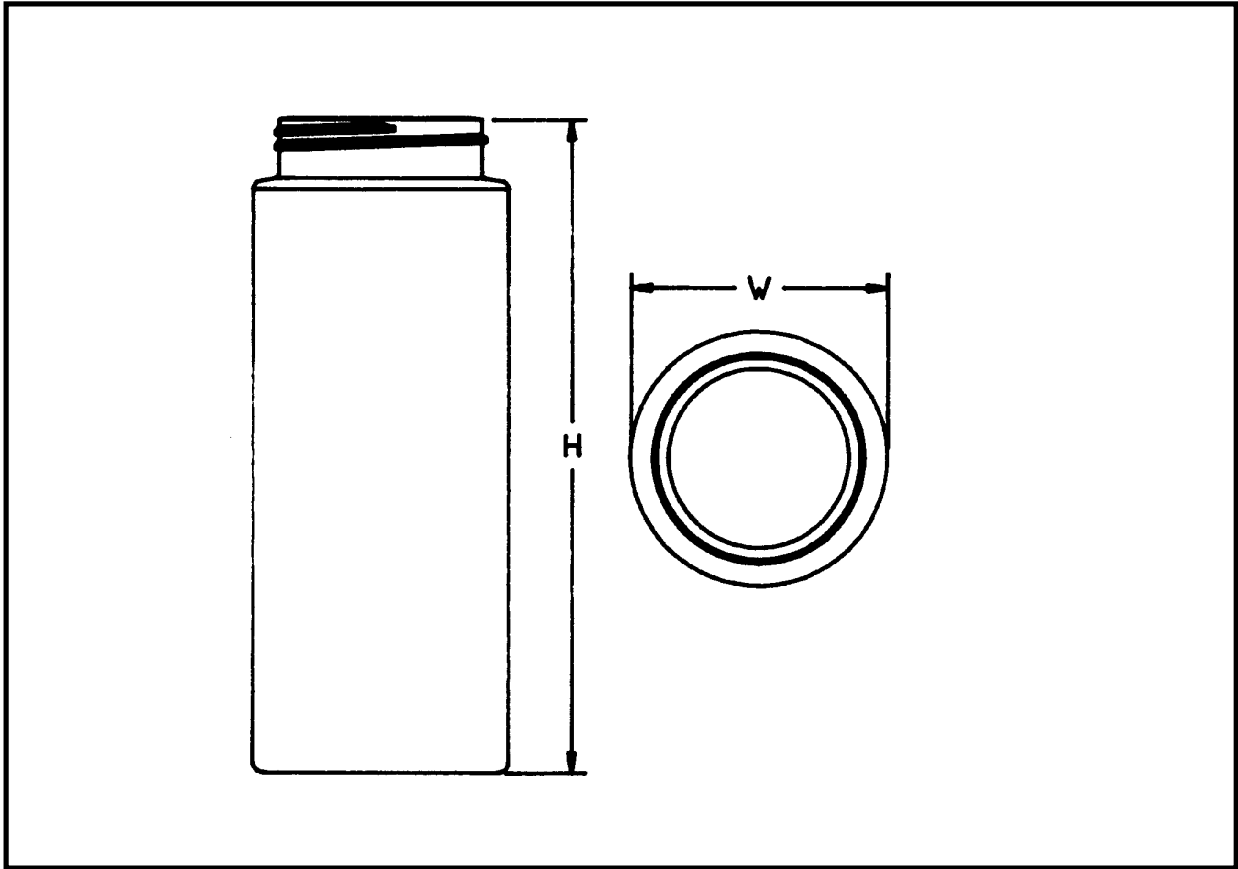

STRAIGHT SIDED CYLINDERS

CAPACITY	NECKS	MATERIAL	HEIGHT	DIAMETER
16 oz	63-485	HDPE	6.21"	2.73"
24 oz / 700 ml	63-485	HDPE	7.565"	2.96"

STRAIGHT SIDED CYLINDERS

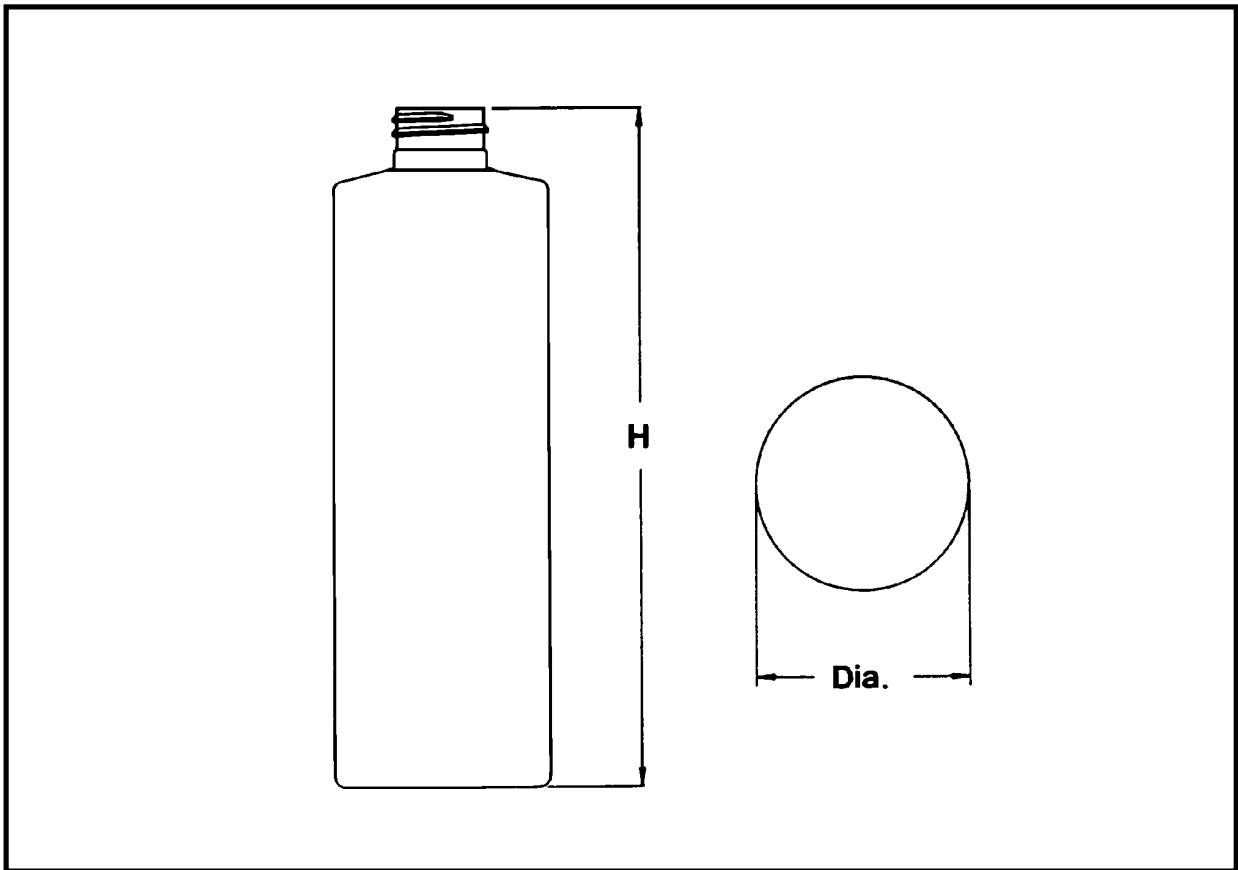

STRAIGHT SIDED CYLINDERS

CAPACITY	NECKS	MATERIAL	HEIGHT	DIAMETER
32 oz / 1 Liter	28-410	HDPE	9.21"	3.22"
32 oz / 1 Liter	38-400	HDPE	8.81"	3.22"
32 oz / 1 Liter	48-400	HDPE	8.81"	3.22"

TALL SLIM CYLINDERS

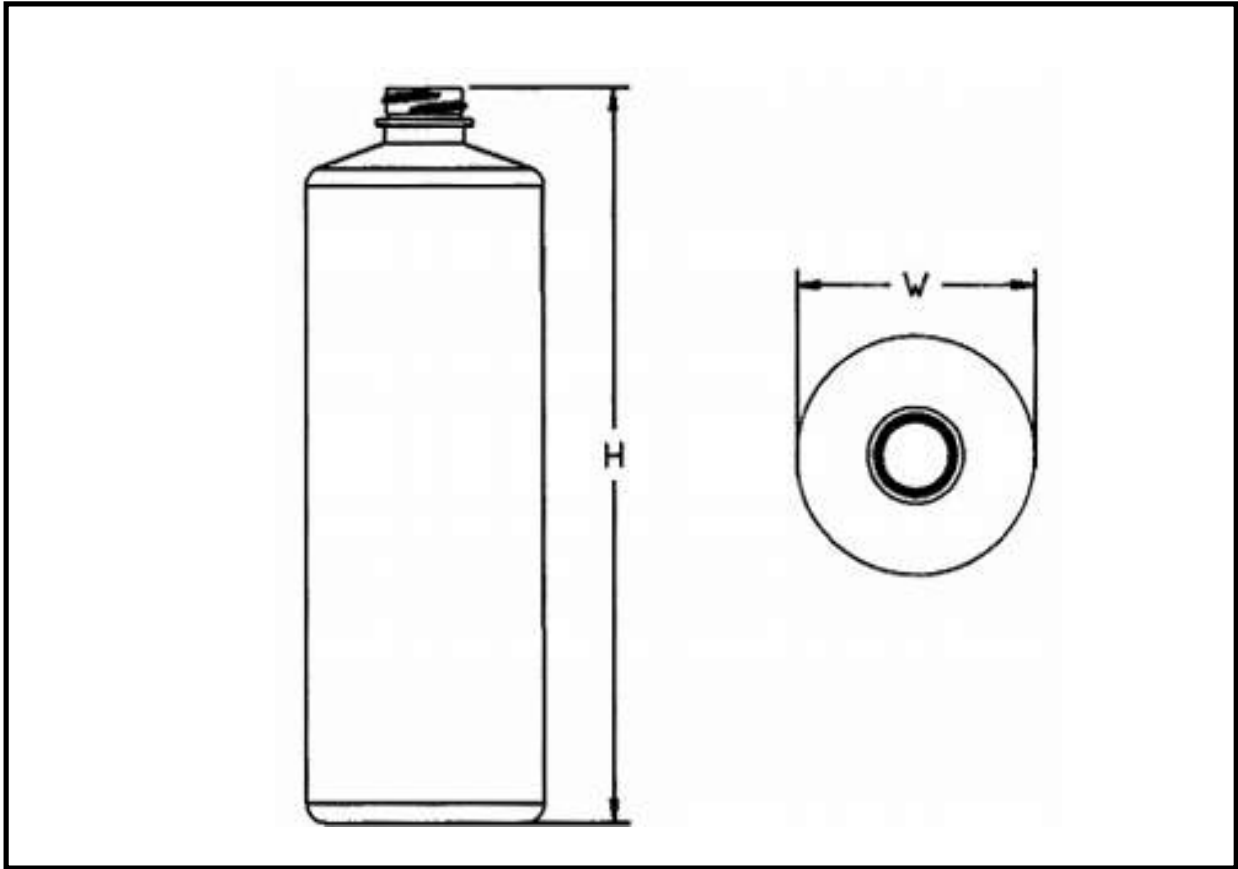

TALL SLIM CYLINDERS

CAPACITY	NECKS	MATERIAL	HEIGHT	DIAMETER
32 oz / 1 Liter	28-400	OPET	9.57"	3.11"

PANELED CYLINDER

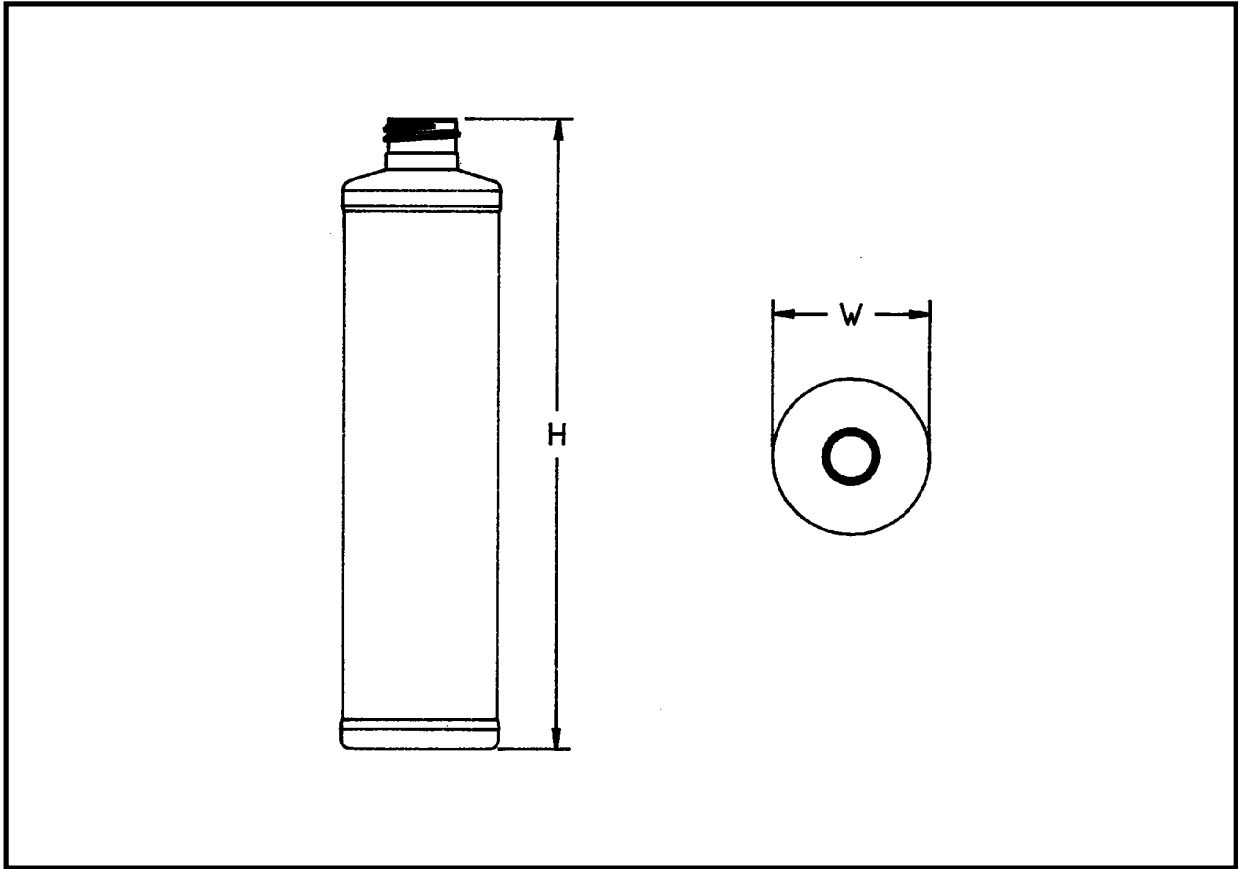

PANELED CYLINDER

CAPACITY	NECKS	MATERIAL	HEIGHT	DIAMETER
10 oz	24-410	HDPE	8.00"	1.975"

PANELED CYLINDERS

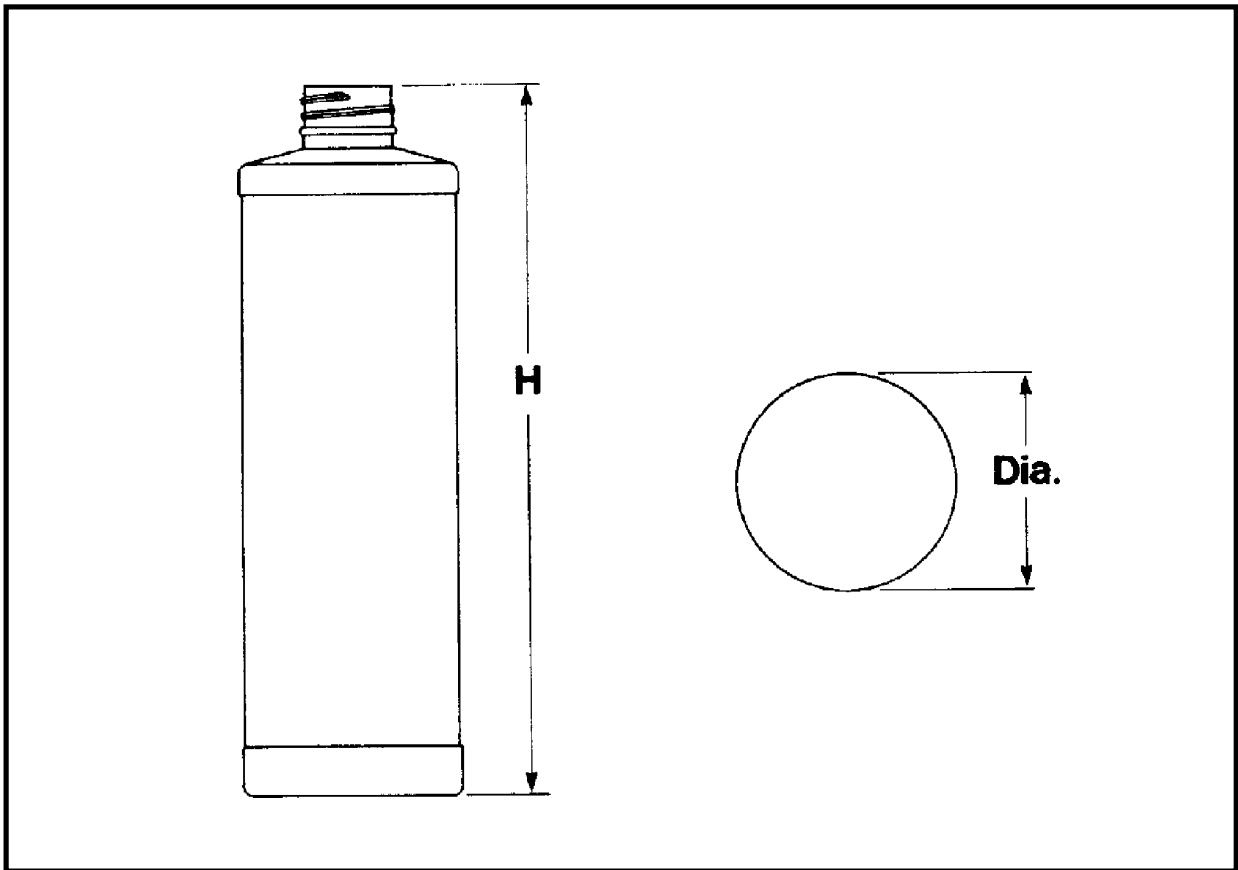

PANELED CYLINDERS

CAPACITY	NECKS	MATERIAL	HEIGHT	DIAMETER
12 oz	24-410	HDPE	7.46"	2.27"
12 oz	28-410	HDPE	7.55"	2.25"
16 oz	28-400sp	HDPE or LDPE	8.00"	2.50"
16 oz	28-410	HDPE or LDPE	8.17"	2.50"

RINGED CYLINDERS

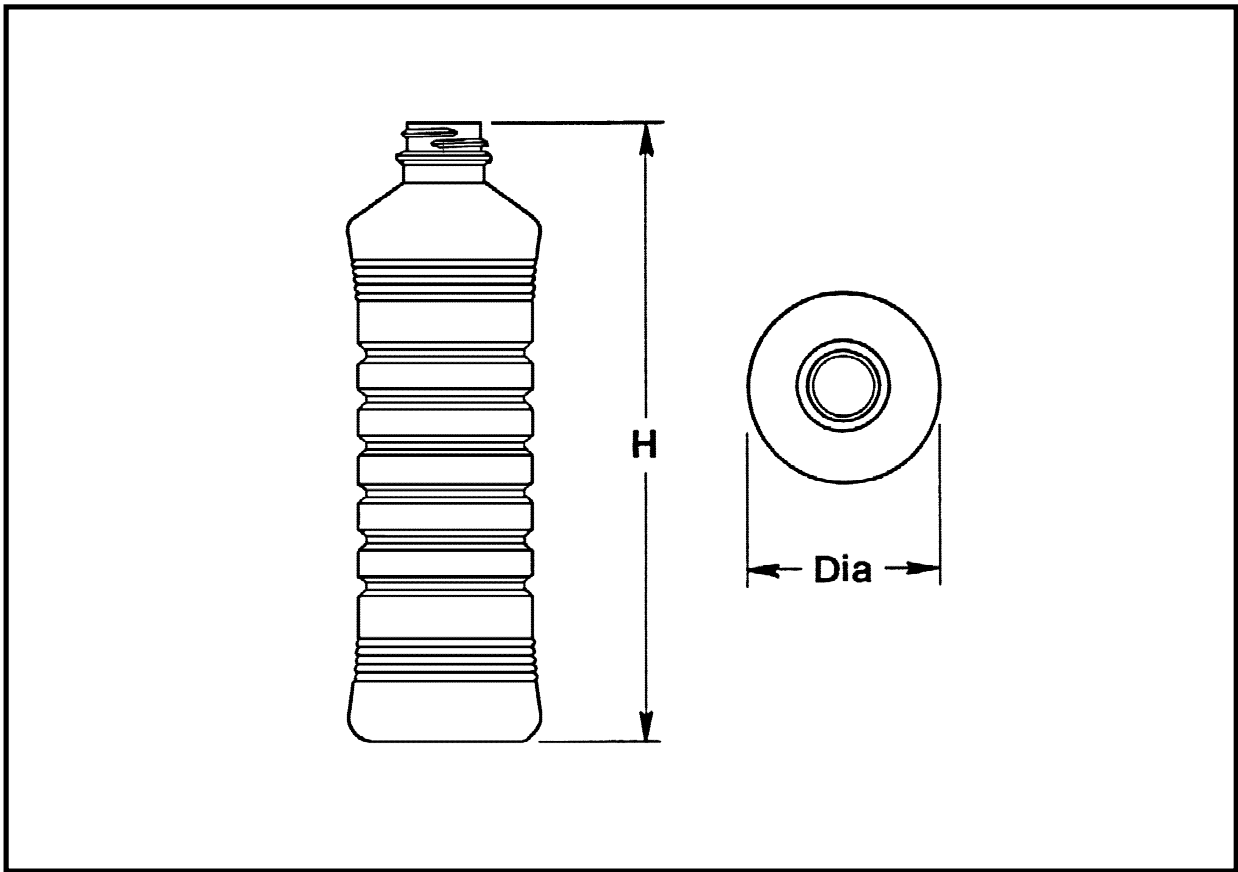

RINGED CYLINDERS

CAPACITY	NECKS	MATERIAL	HEIGHT	DIAMETER
15 oz	33-400	PVC	8.00"	2.50"



OVALS

Where great ideas take shape.

#639 ADDITIVE OVALS

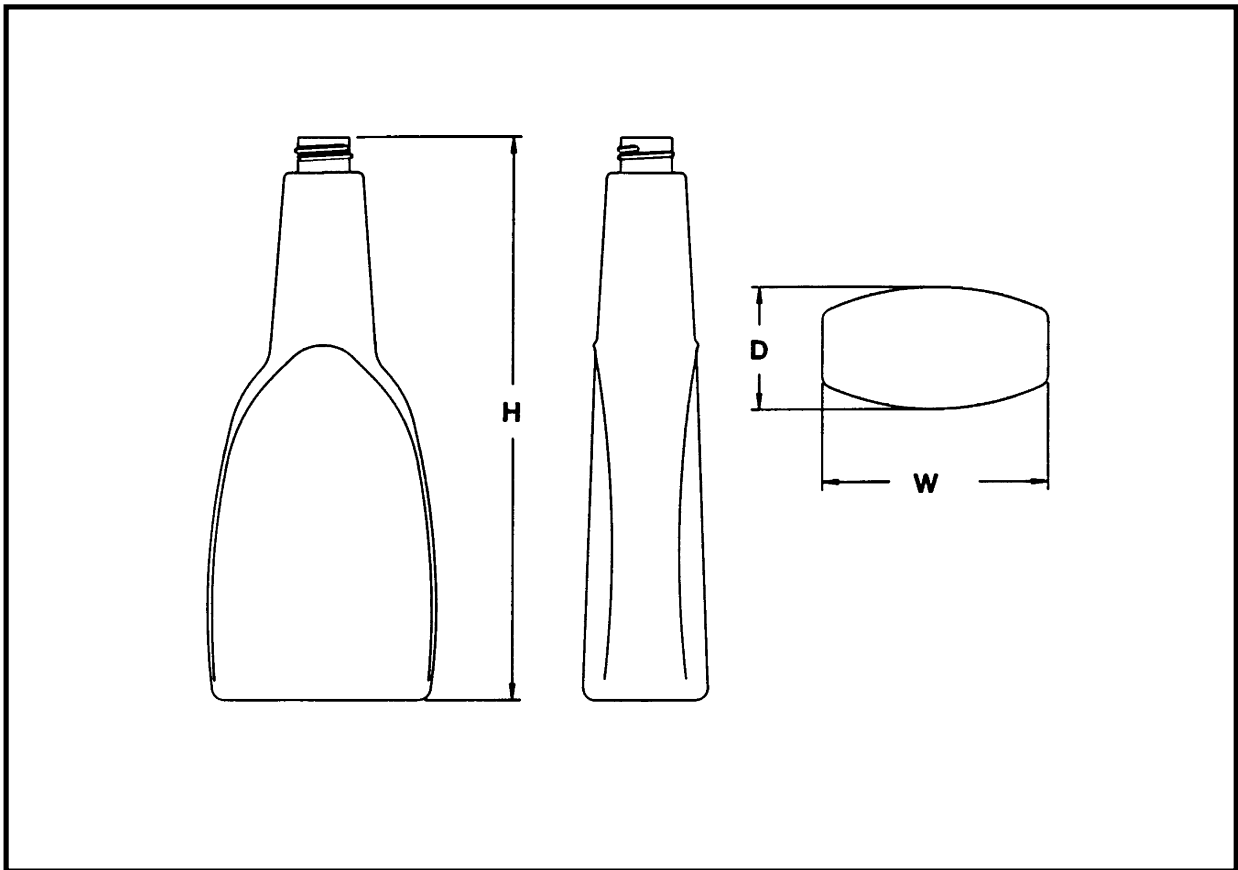

#639 ADDITIVE OVALS

CAPACITY	NECKS	MATERIAL	HEIGHT	WIDTH	DEPTH
8 oz	22-400 .371"H +/- .015"	PVC	8.00"	2.96"	1.56"
8 oz	22-400 .480"H +/- .015"	PVC	8.08"	2.96"	1.56"
8 oz	22-415	PVC	8.00"	2.96"	1.56"

#639 ADDITIVE OVAL

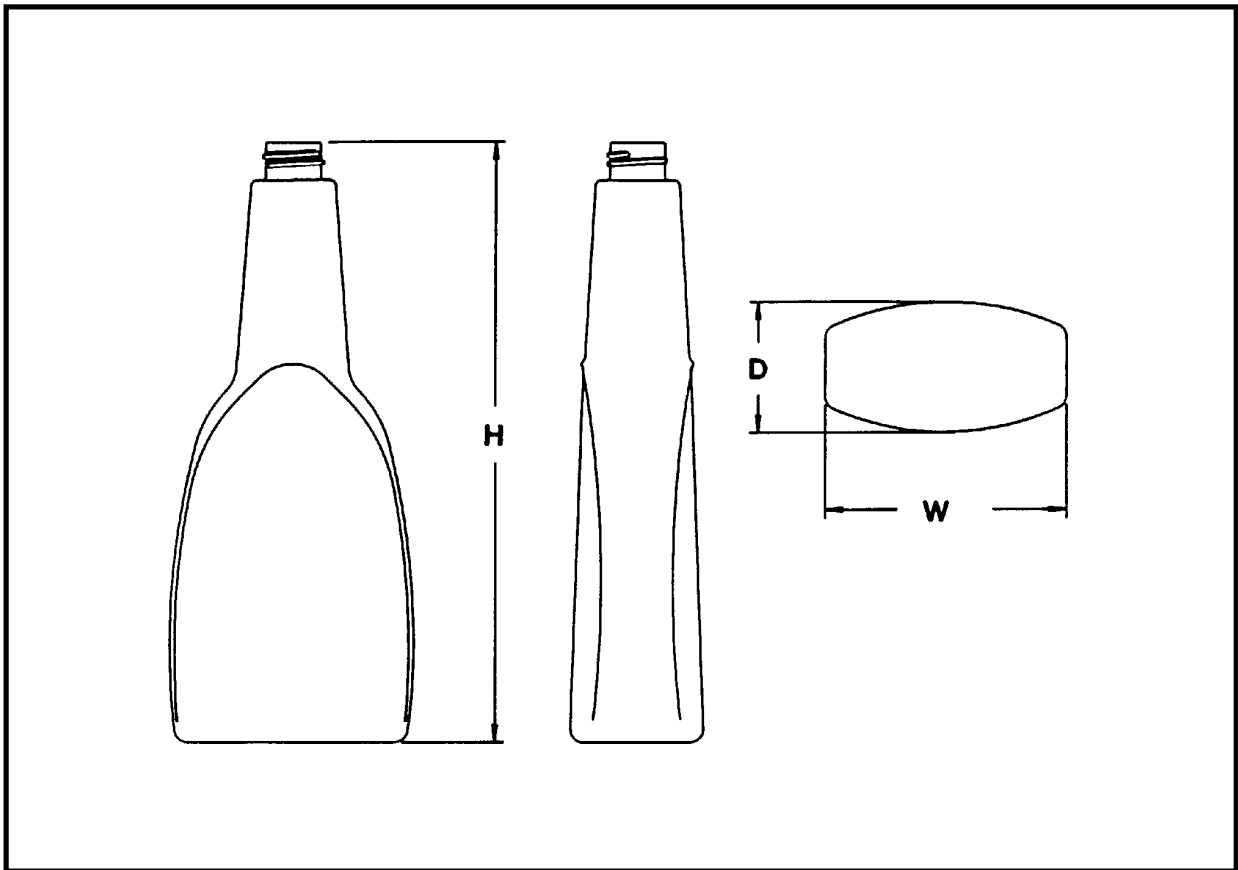

#639 ADDITIVE OVAL

CAPACITY	NECKS	MATERIAL	HEIGHT	WIDTH	DEPTH
12 oz	22-400 .475" H"	PVC	8.425"	3.39"	1.86"

#639 ADDITIVE OVALS

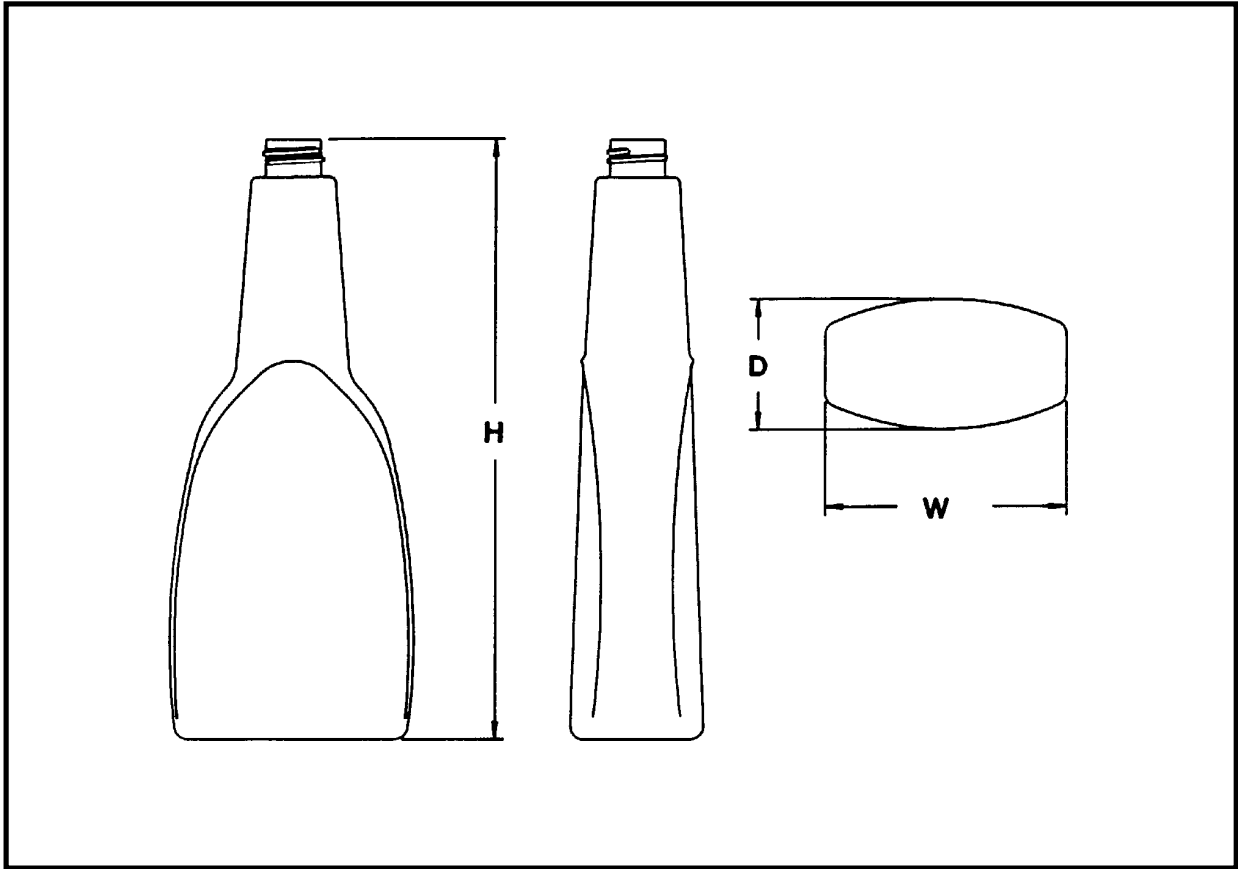

#639 ADDITIVE OVALS

CAPACITY	NECKS	MATERIAL	HEIGHT	WIDTH	DEPTH
32 oz / 1 liter	28-400*	HDPE	10.144"	4.47"	2.94"
32 oz / 1 liter	28-400**	HDPE	10.18"	4.47"	2.94"

* .385"-.415" "H" Dimension

** .421"-.451" "H" Dimension

FLEUR DE LIS TOTTLE

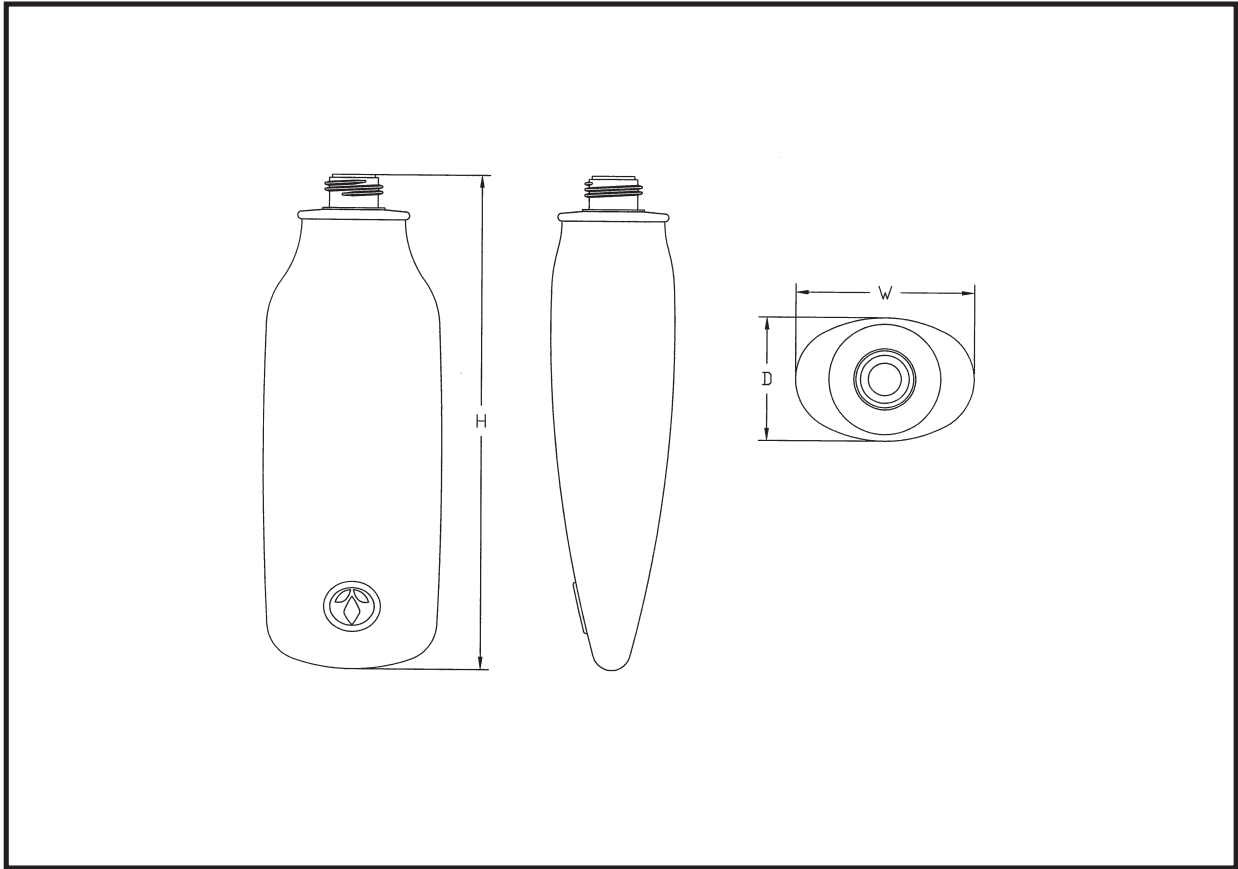

FLEUR DE LIS TOTTLE

CAPACITY	NECKS	MATERIAL	HEIGHT	WIDTH	DEPTH
2 oz	Special Neck*	HDPE	4.813"	1.728"	1.21"

*Special neck, others can be built based upon customer request.

FLEUR DE LIS TOTTLE

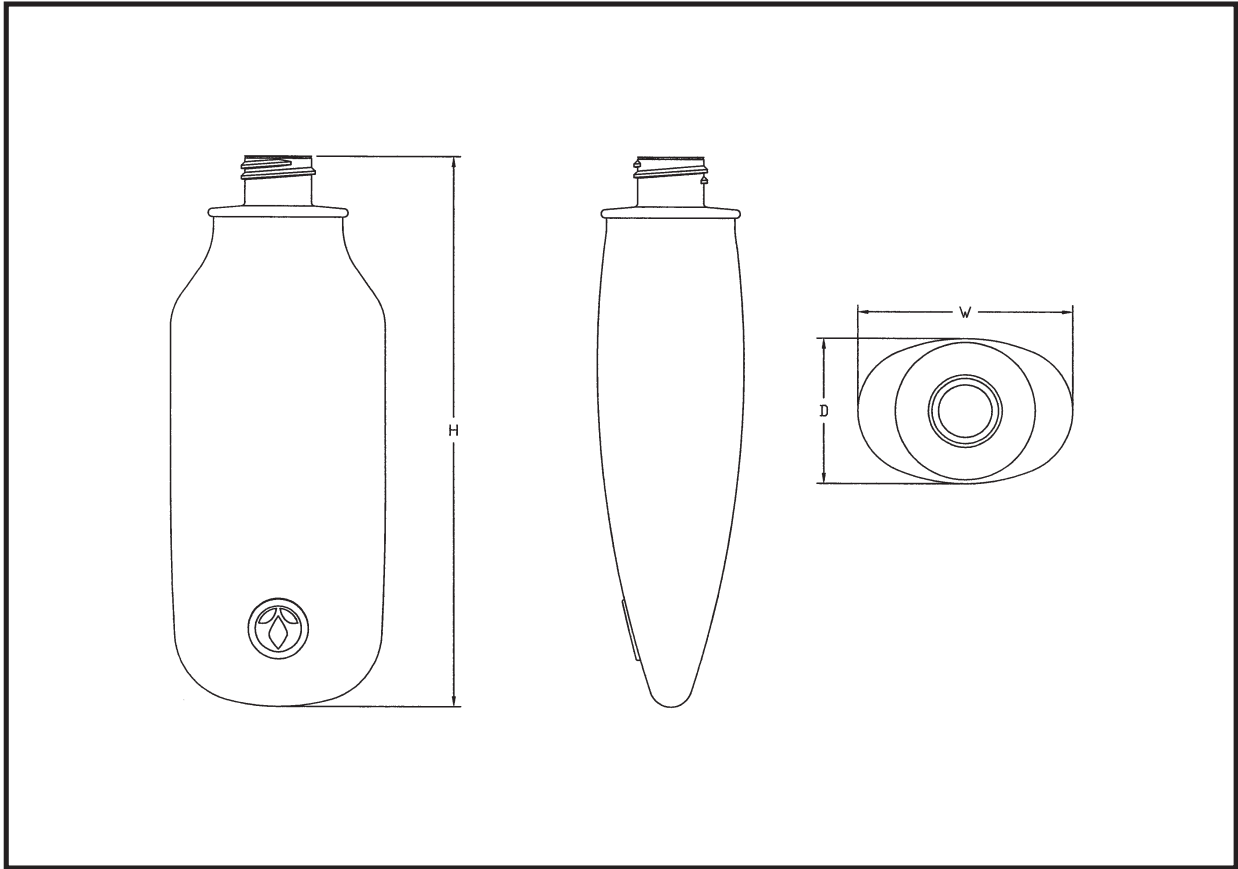

FLEUR DE LIS TOTTLE

CAPACITY	NECKS	MATERIAL	HEIGHT	WIDTH	DEPTH
6 oz	22-400	HDPE	6.224"	2.485"	1.71"

FLEUR DE LIS OVALS

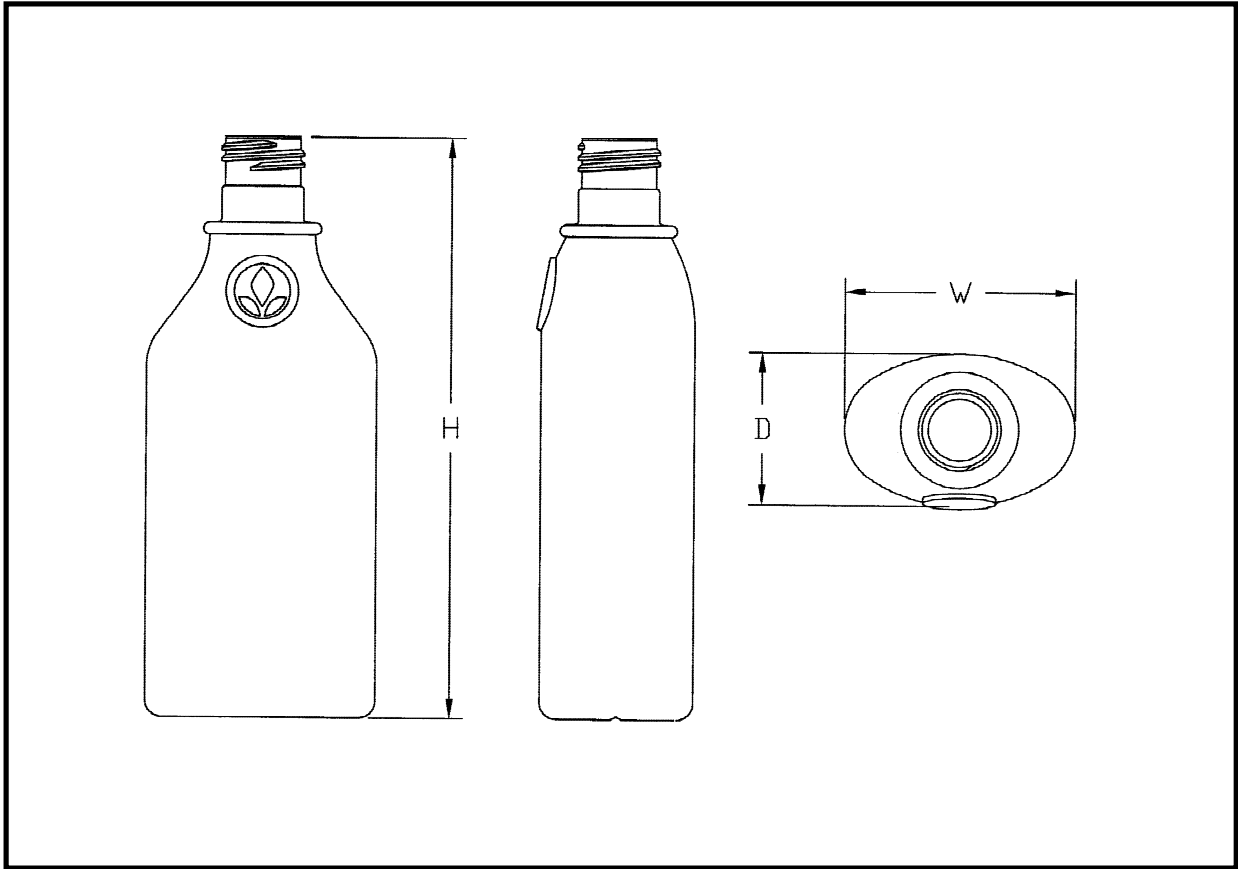

FLEUR DE LIS OVALS

CAPACITY	NECKS	MATERIAL	HEIGHT	WIDTH	DEPTH
8 oz	24-410	PVC	6.288"	2.595"	1.742"
8 oz	24-415	PVC	6.599"	2.595"	1.742"

*Uses 20mm Tall fl= valve seal closure from Berry Plastics or Packaging Design Group.
 For a 50,000 piece order, we could look at building an OPET version.

FOOTED FLEUR DE LIS OVAL

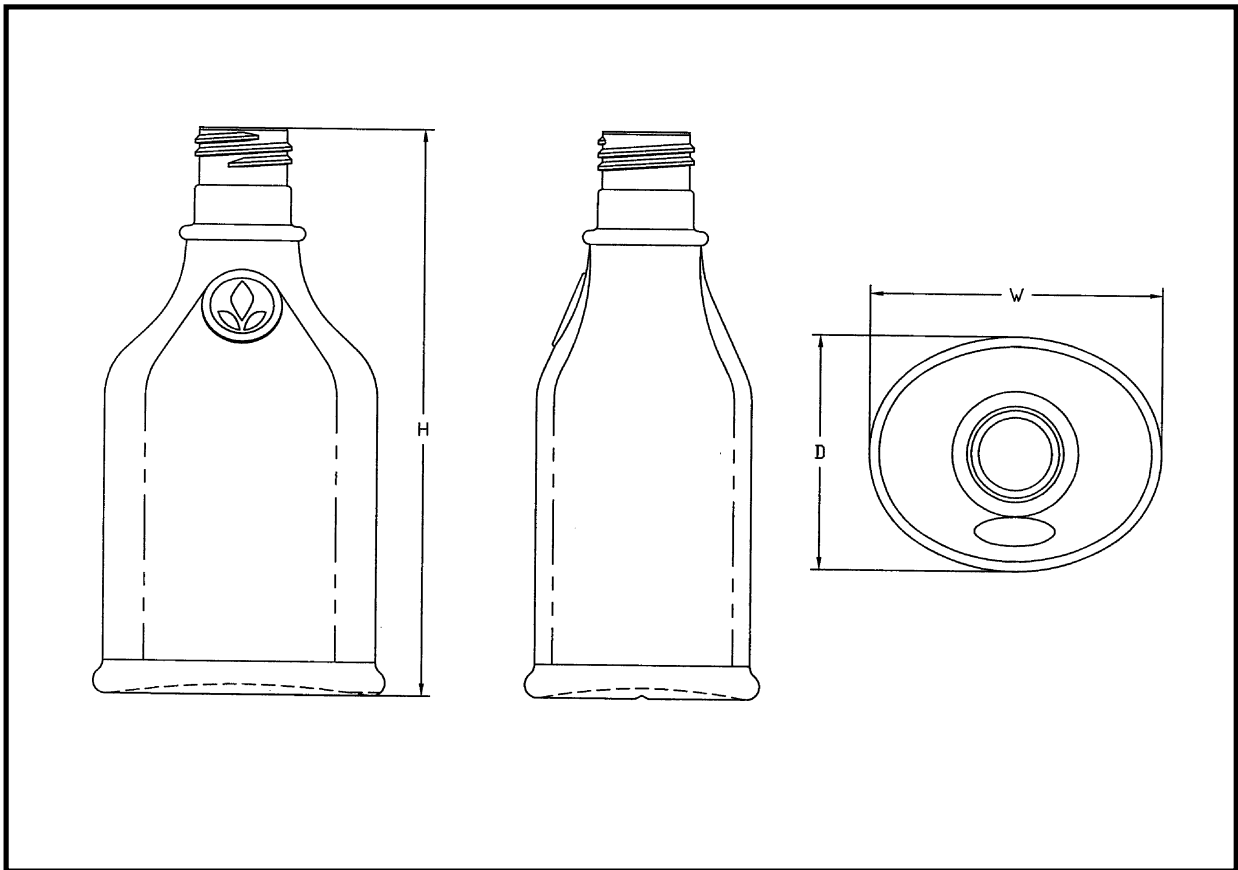

FOOTED FLEUR DE LIS OVAL

CAPACITY	NECKS	MATERIAL	HEIGHT	WIDTH	DEPTH
8 oz	24-415	PVC	5.506"	2.82"	2.28"

For a 50,000 piece order, we could look at building an OPET version.

FACETED OVALS

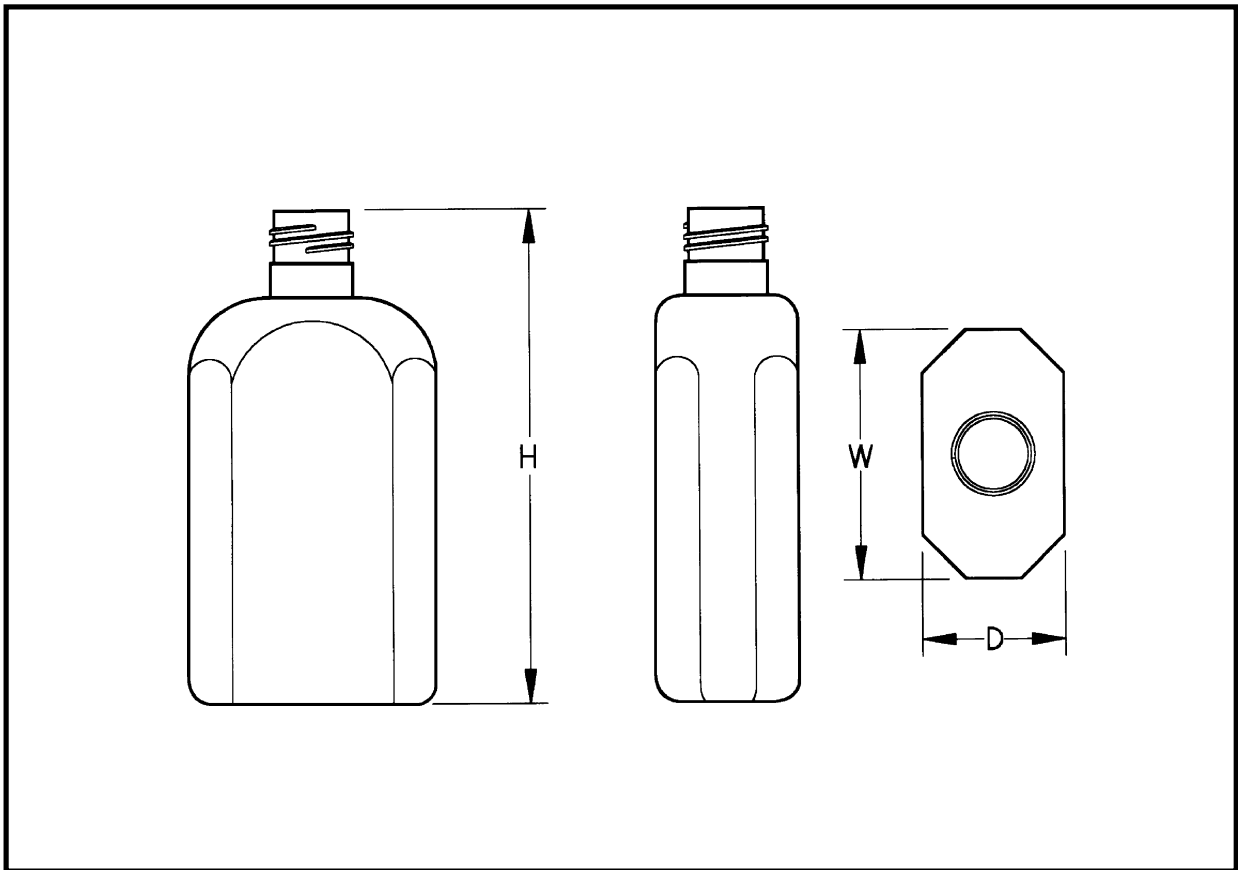

FACETED OVALS

CAPACITY	NECKS	MATERIAL	HEIGHT	WIDTH	DEPTH
2 oz/2.75	20-410	PVC	3.40"	1.91"	1.13"
2 oz/2.75	20-415	PVC	3.67"	1.91"	1.13"
2 oz/2.75	R4/20	PVC	4.02"	1.91"	1.13"
8 oz/8.50	24-410	PVC	5.25"	2.80"	1.61"
8 oz/8.50	24-415 + R4/24	PVC	5.54"	2.80"	1.61"

Secondary capacity measurement represents cosmetic fill point to base of neck.
 For a 50,000 piece order, we could look at building an OPET version.

LAURA OVAL

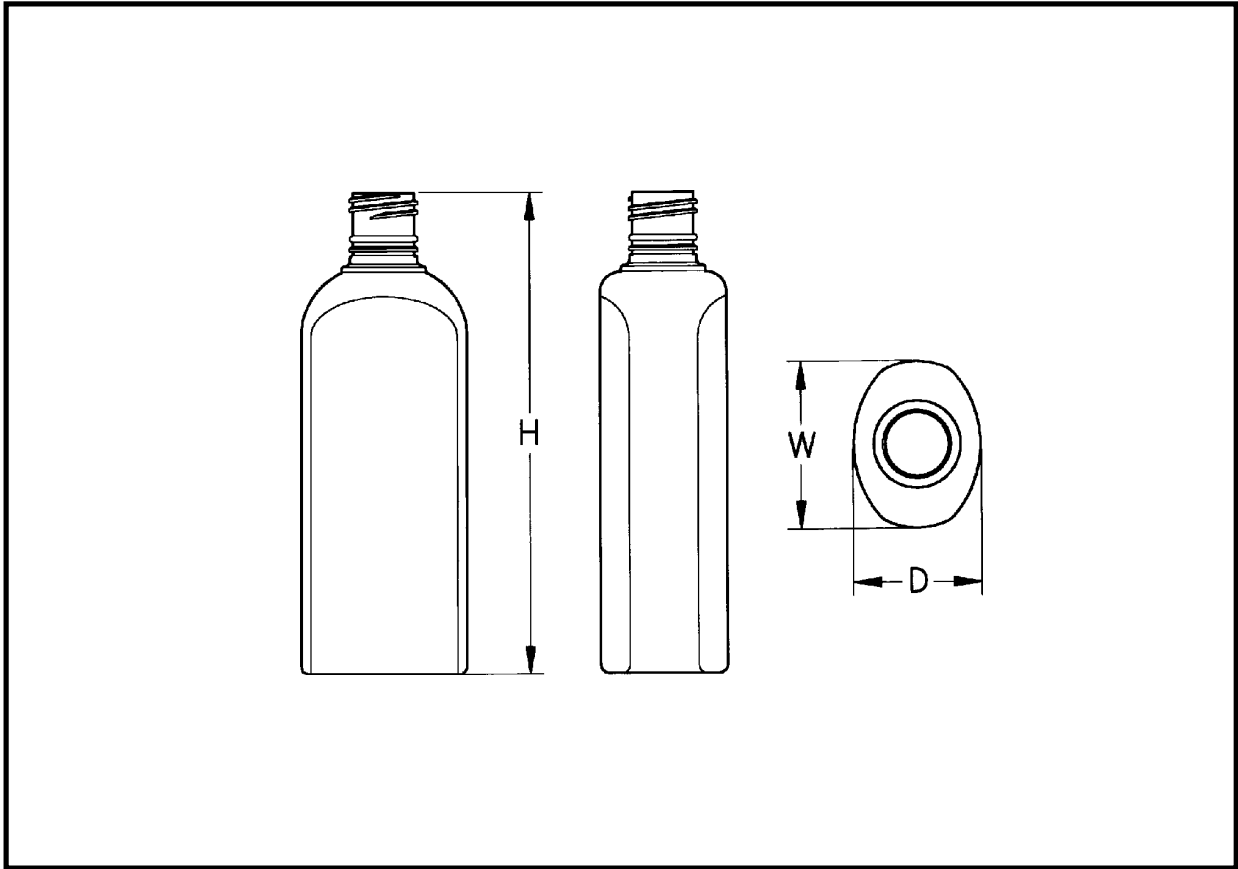

LAURA OVAL

CAPACITY	NECKS	MATERIAL	HEIGHT	WIDTH	DEPTH
2 / 2.76 oz	20-415	PVC	4.38"	1.67"	1.27"

Secondary capacity measurement represents cosmetic fill point to base of neck.
 For a 50,000 piece order, we could look at building an OPET version.

LAURA OVALS

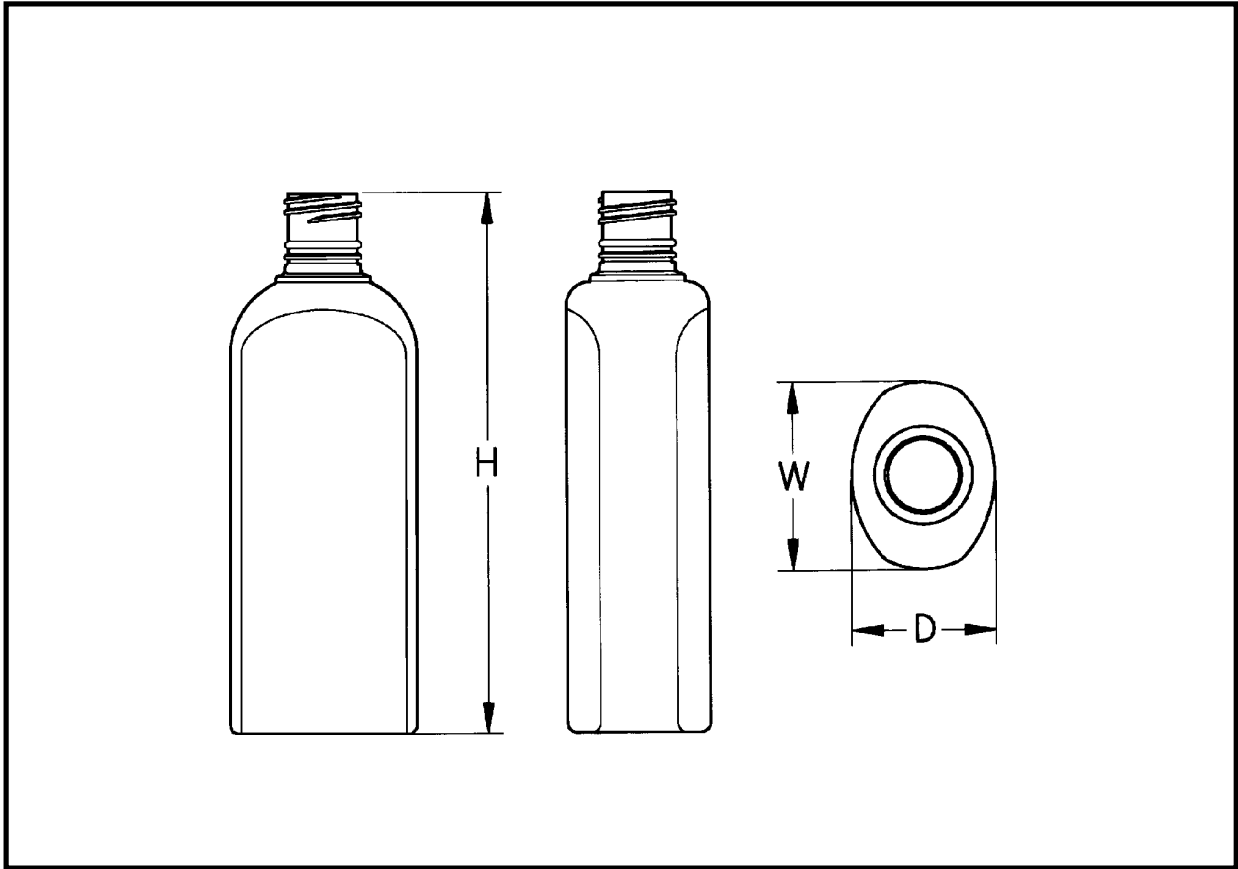

LAURA OVALS

CAPACITY	NECKS	MATERIAL	HEIGHT	WIDTH	DEPTH
4 /4.79 oz	24-415	PVC	5.10"	1.95"	1.50"
8 /9.11 oz	24-410	PVC	6.25"	2.28"	1.75"
8 /9.11 oz	24-415	PVC	6.58"	2.28"	1.75"

Secondary capacity measurement represents cosmetic fill point to base of neck.
 For a 50,000 piece order, we could look at building an OPET version.

VALE OVALS

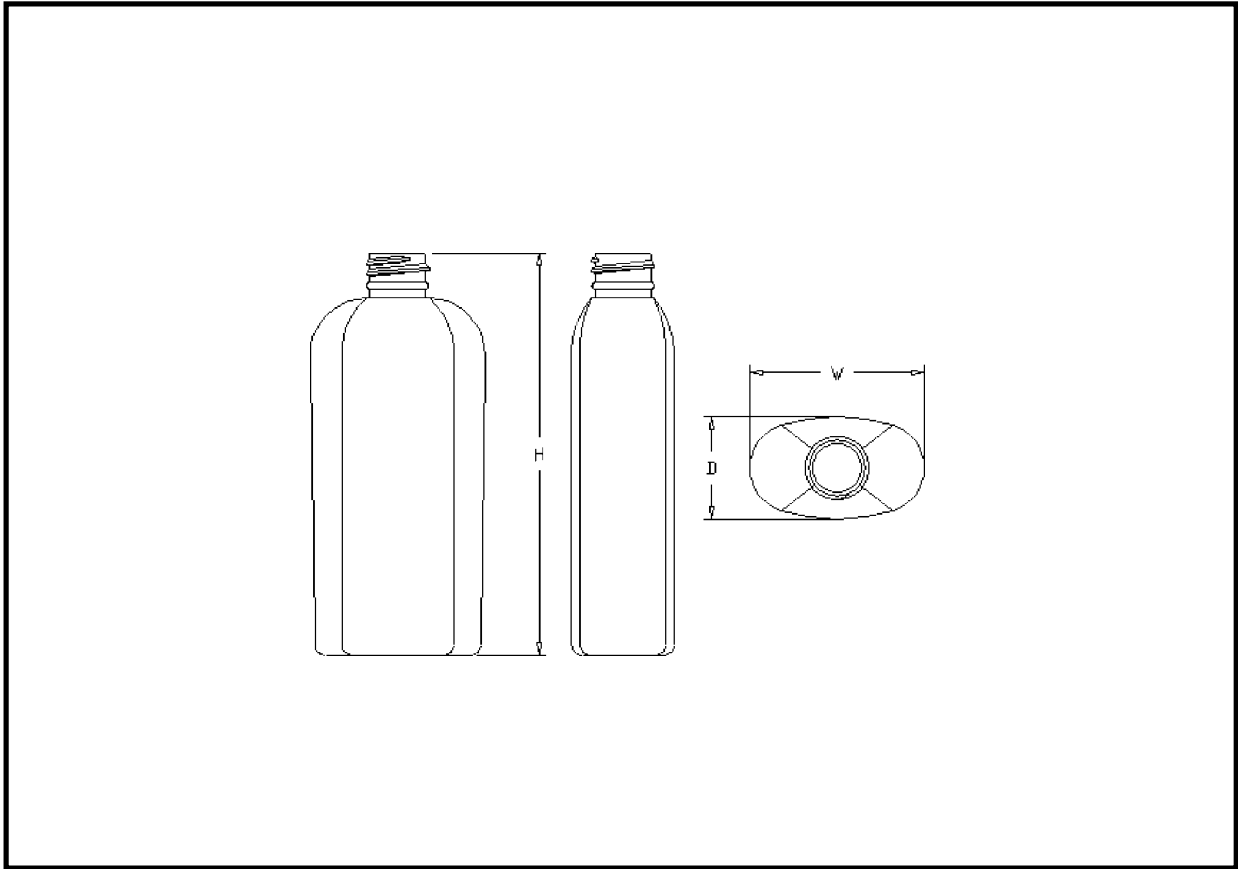

VALE OVALS

CAPACITY	NECKS	MATERIAL	HEIGHT	WIDTH	DEPTH
2 oz	20-410	OPET	4.1"	1.675"	1.050"
2 oz	20-415	OPET	4.285"	1.675"	1.050"
4 oz	20-410	OPET	4.933"	2.14"	1.296"
4 oz	20-415	OPET	5.125"	2.14"	1.296"
8 oz	24-410	OPET	6.195"	2.575"	1.624"
8 oz	24-415	OPET	6.511"	2.575"	1.624"
12 oz	24-410	OPET	6.996"	2.785"	1.63"
12 oz	24-415	OPET	7.307"	2.785"	1.63"

RIBBED OVALS

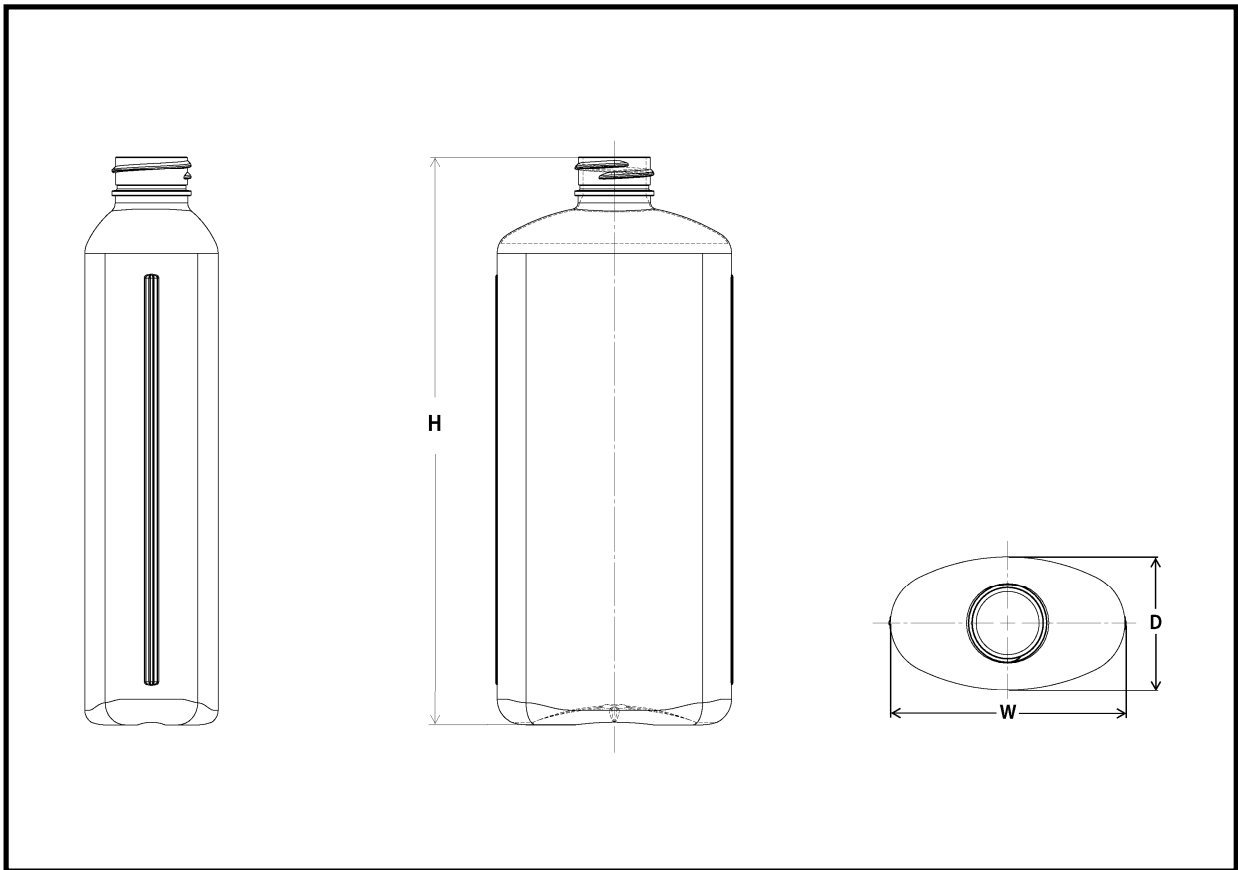

RIBBED OVALS

CAPACITY	NECKS	MATERIAL	HEIGHT	WIDTH	DEPTH
16 oz	28-410	OPET	7.77"	3.24"	1.82"
16 oz	28-415	OPET	8.16"	3.24"	1.82"

STRAIGHT SIDED OVAL

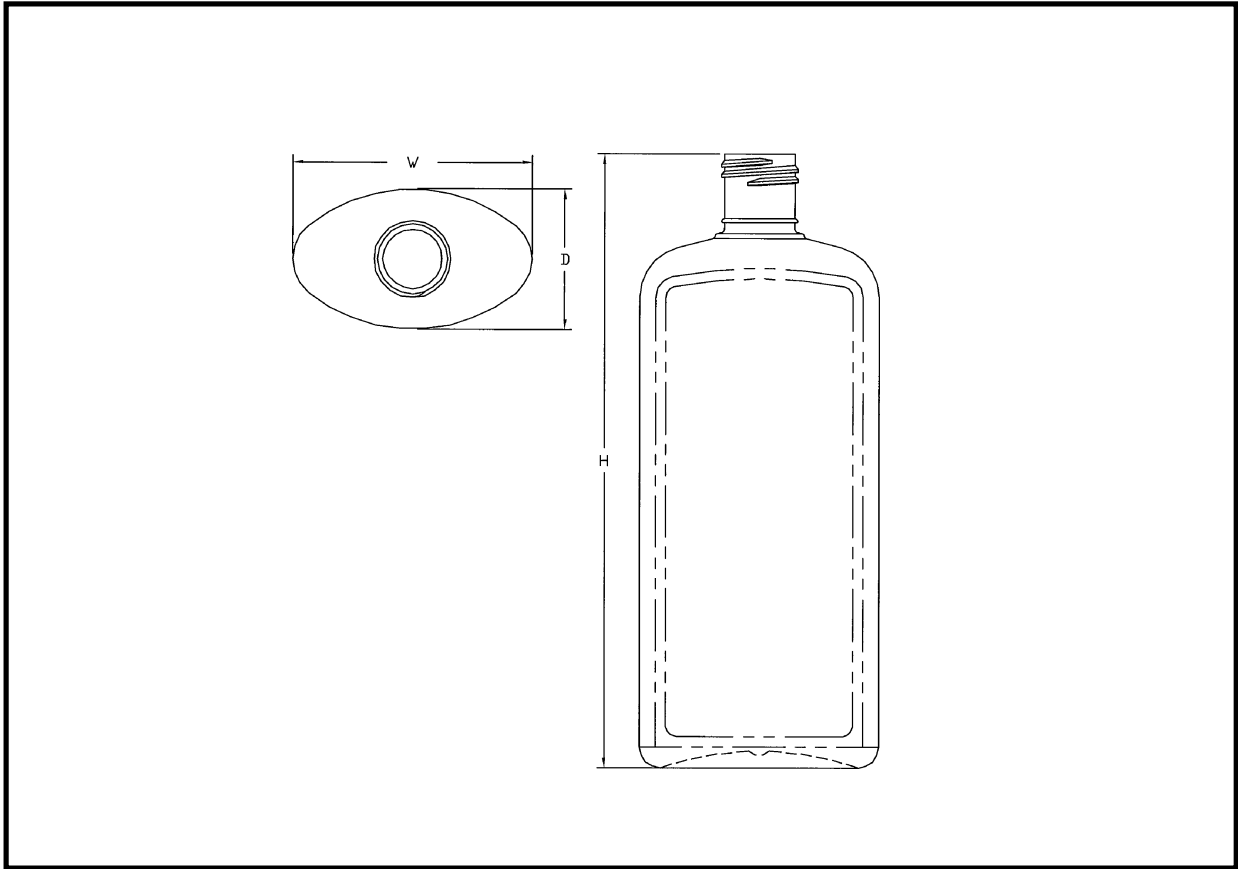

STRAIGHT SIDED OVAL

CAPACITY	NECKS	MATERIAL	HEIGHT	WIDTH	DEPTH
12 oz	24-410	OPET	7.119"	2.90"	1.70"
12 oz	24-415	OPET	7.43"	2.90"	1.70"
16 oz	28-410	OPET	8.012"	3.20"	1.844"
16 oz	28-415	OPET	8.386"	3.20"	1.844"

SANTA FE OVAL

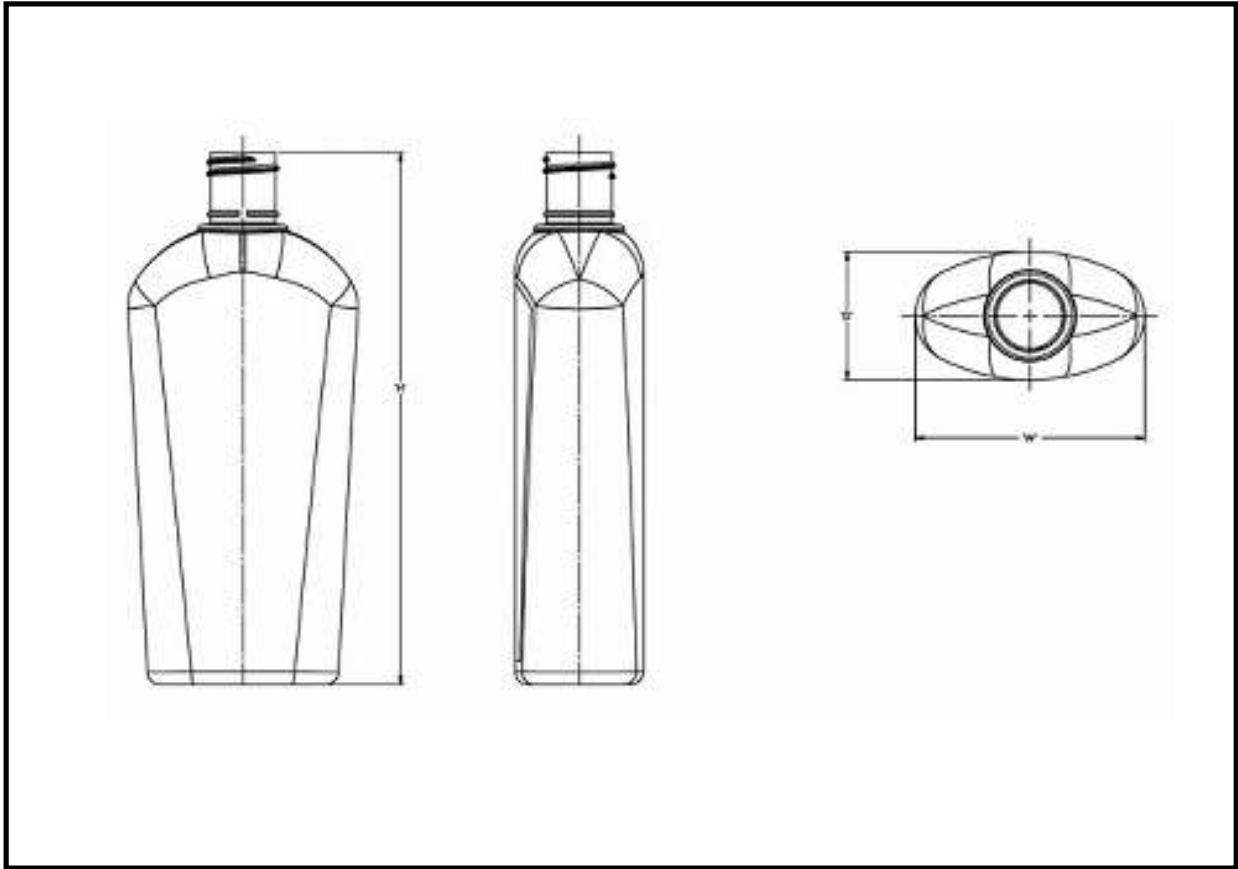

SANTA FE OVAL

CAPACITY	NECKS	MATERIAL	HEIGHT	WIDTH	DEPTH
16 oz / 500 ml	28-410	OPET	7.626"	2.875"	1.929"
16 oz / 500 ml	28-415	OPET	8.00"	2.875"	1.929"

OLYMPIAN OVALS

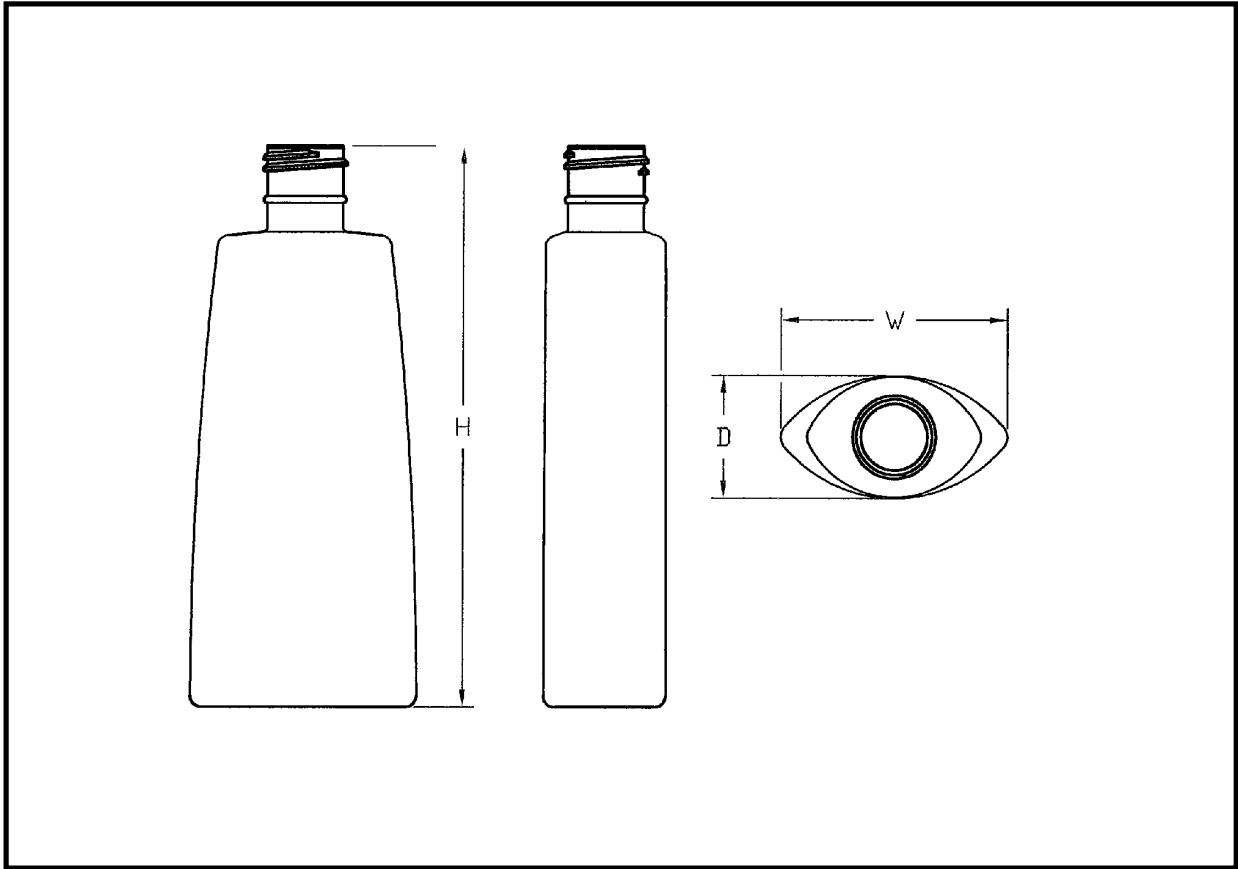

OLYMPIAN OVALS

CAPACITY	NECKS	MATERIAL	HEIGHT	WIDTH	DEPTH
2 oz	20-410	OPET	4.062"	1.70"	0.944"
2 oz	20-415	OPET	4.25"	1.70"	0.944"
5 oz	24-410	OPET	5.62"	2.421"	1.347"
6 oz	24-410	OPET	5.95"	2.527"	1.37"
6 oz	24-415	OPET	6.261"	2.527"	1.37"
8 oz	24-410	OPET	6.4"	2.813"	1.474"
8 oz	24-415	OPET	6.71"	2.813"	1.474"

OPTIMUM OVAL

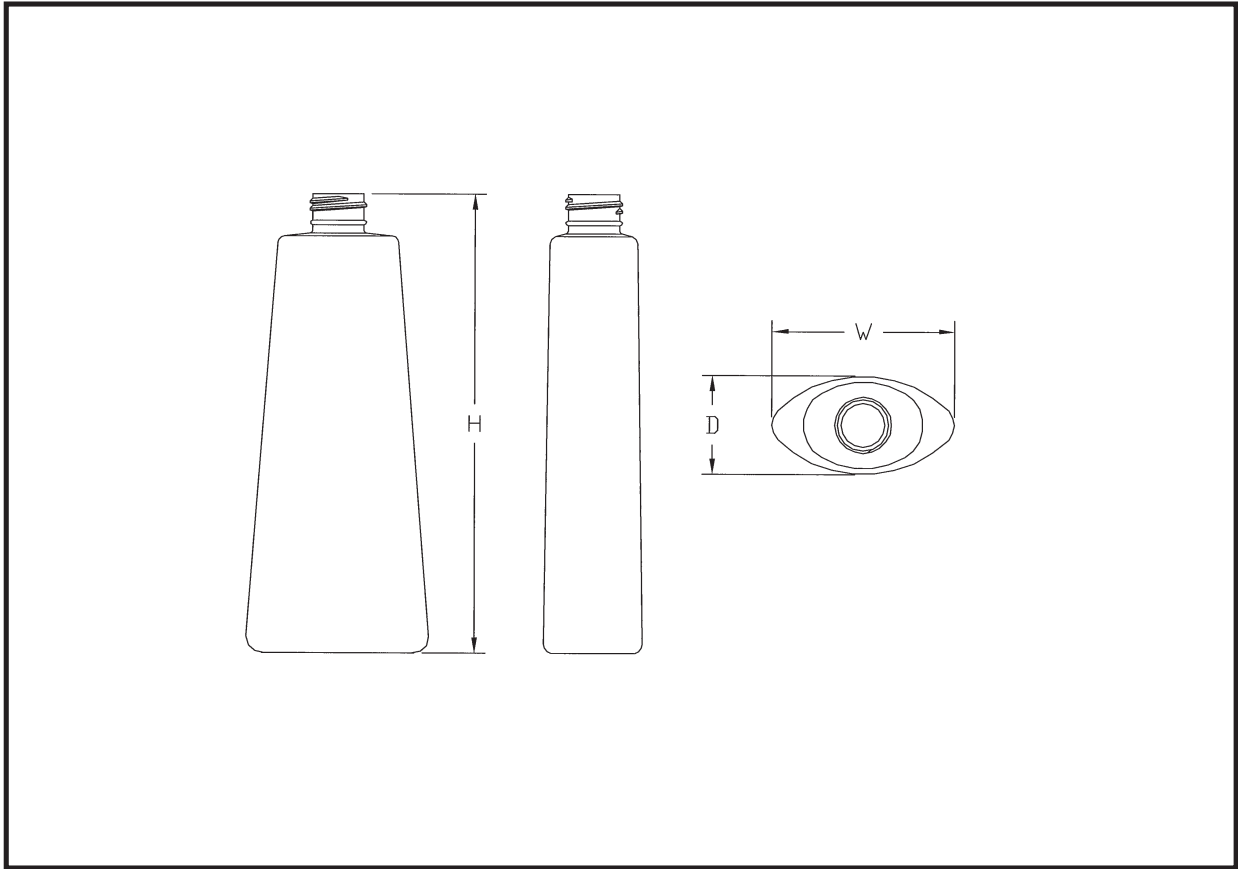

OPTIMUM OVAL

CAPACITY	NECKS	MATERIAL	HEIGHT	WIDTH	DEPTH
10 oz	24-410	OPET	7.55"	3.09"	1.625"
10 oz	24-415	OPET	7.861"	3.09"	1.625"

CUSTOM OVALS

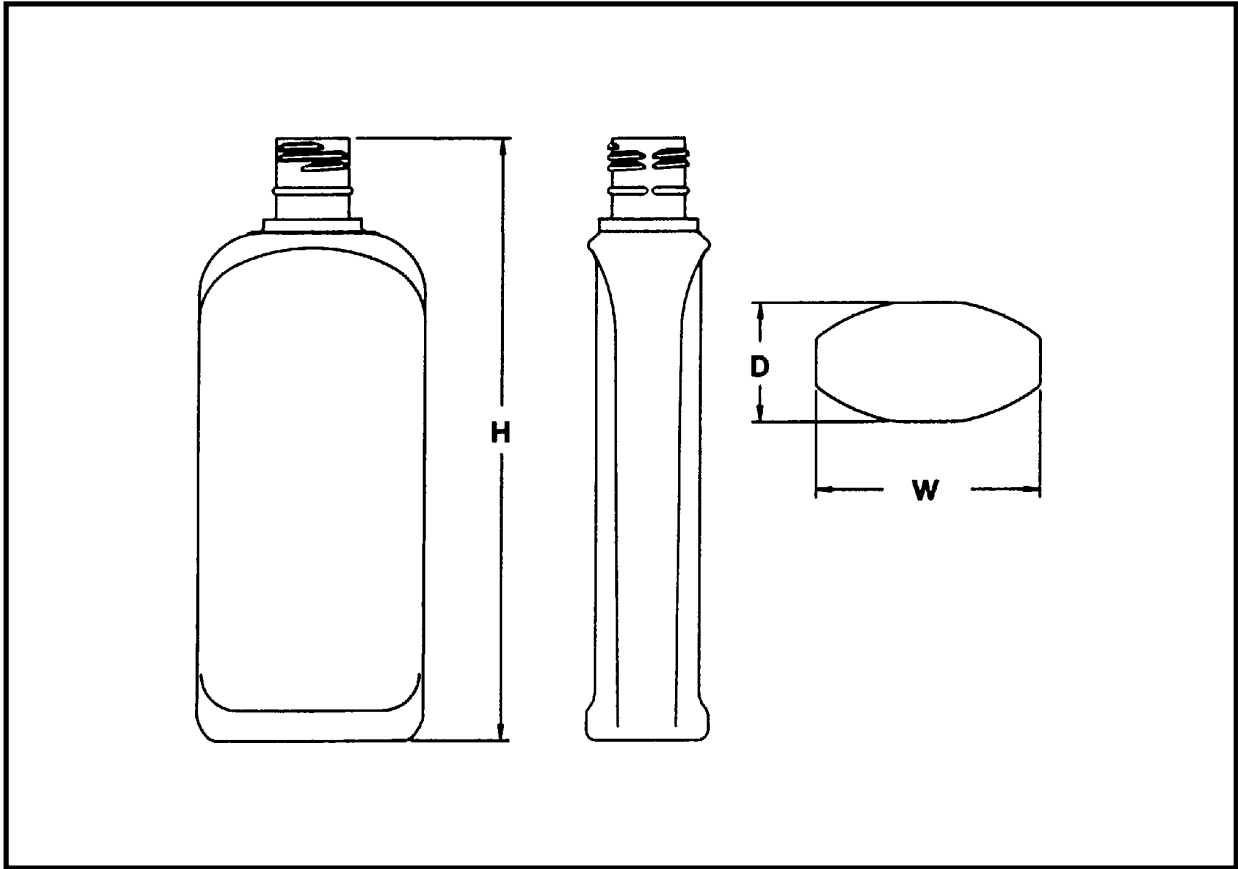

CUSTOM OVALS

CAPACITY	NECKS	MATERIAL	HEIGHT	WIDTH	DEPTH
4 /4.24 oz	20-410	PVC	5.46"	2.08"	1.15"
4 /4.24 oz	20-415	PVC	5.66"	2.08"	1.15"

Secondary capacity measurement represents cosmetic fill point to base of neck.

ASHLEY OVALS

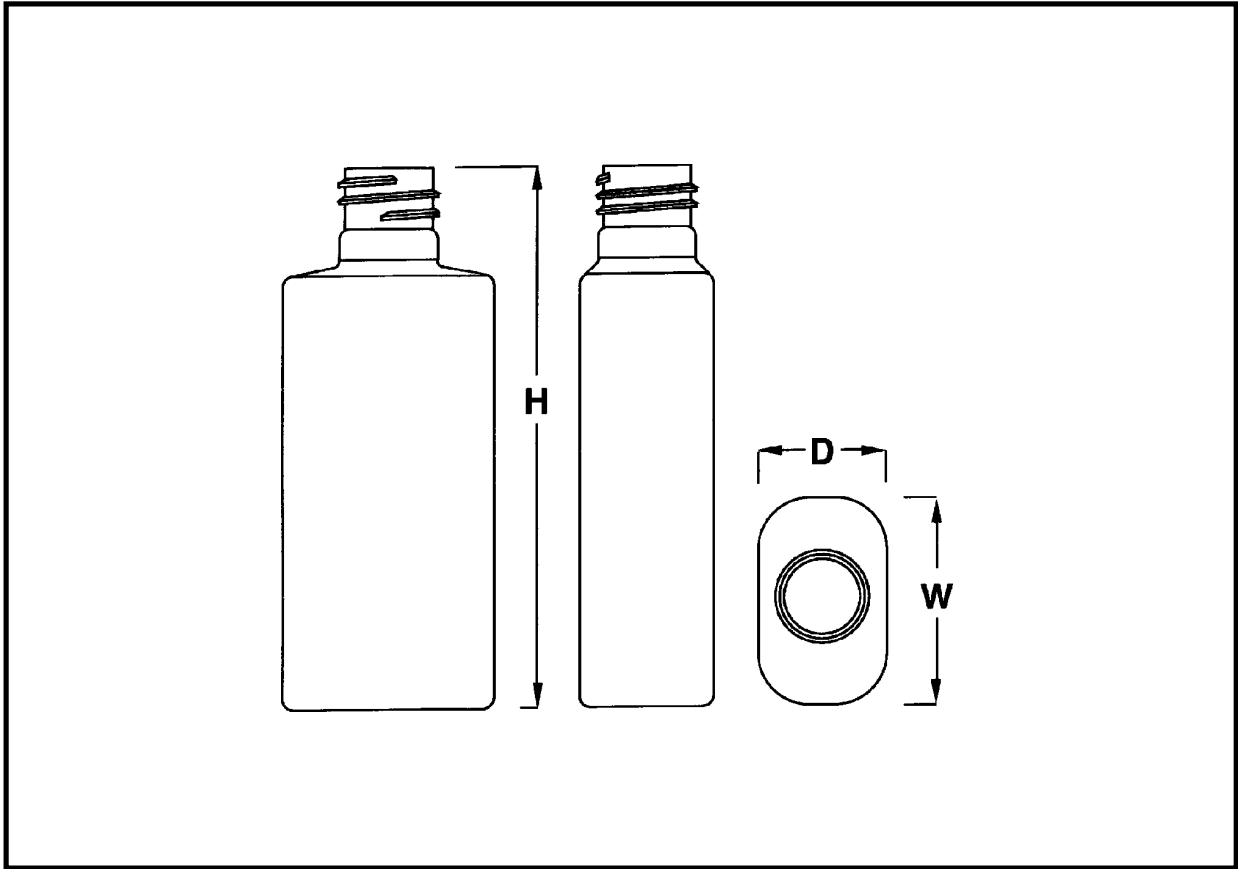

ASHLEY OVALS

CAPACITY	NECKS	MATERIAL	HEIGHT	WIDTH	DEPTH
2 /2.57 oz	20-415	PVC	4.28"	1.61"	1.04"
8 /8.69 oz	24-415	PVC	5.82"	2.44"	1.69"

Secondary capacity measurement represents cosmetic fill point to base of neck.
 For a 50,000 piece order, we could look at building an OPET version.

MALIBU TOTTLE

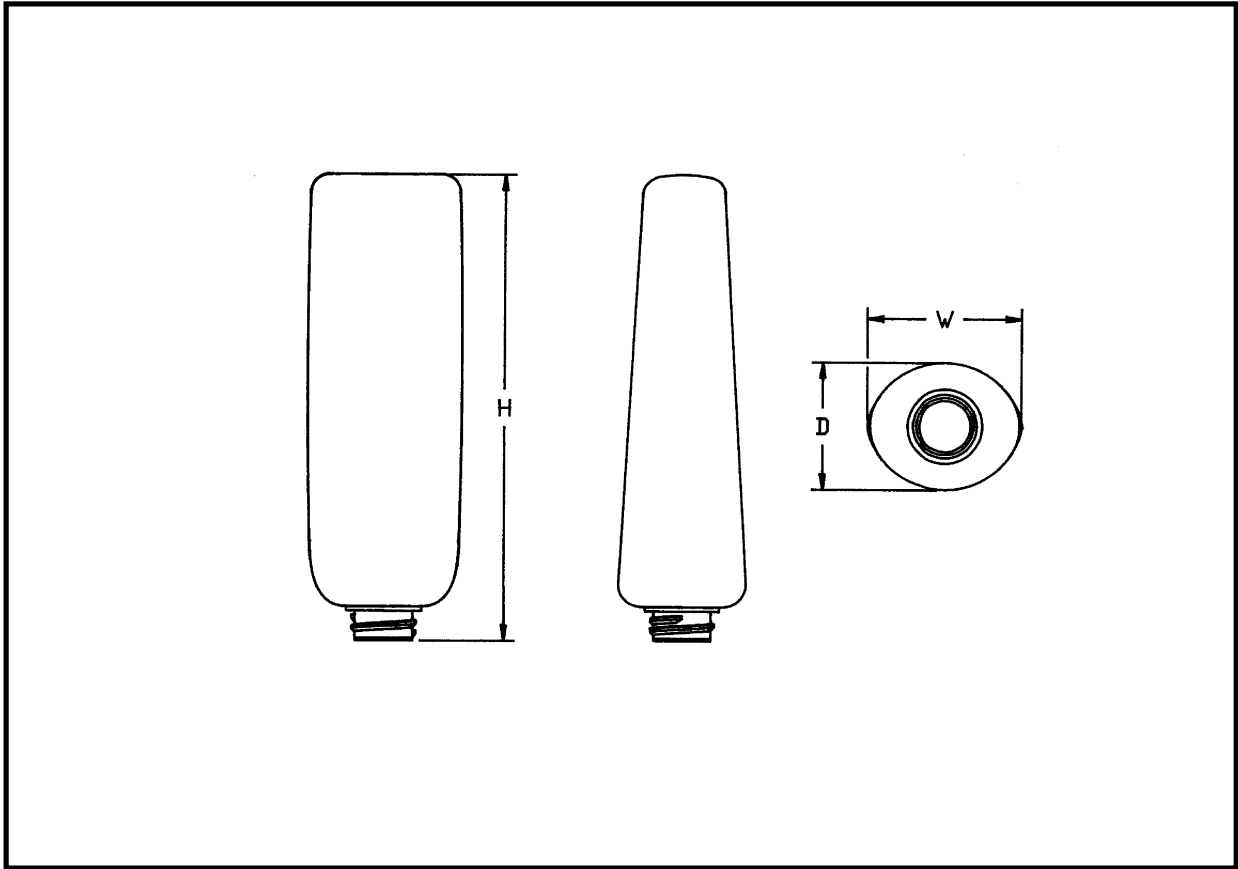

MALIBU TOTTLE

CAPACITY	NECKS	MATERIAL	HEIGHT	WIDTH	DEPTH
6 oz	22-400	HDPE, LDPE or MDPE	6.267"	2.055"	1.71"

POCKET OVAL

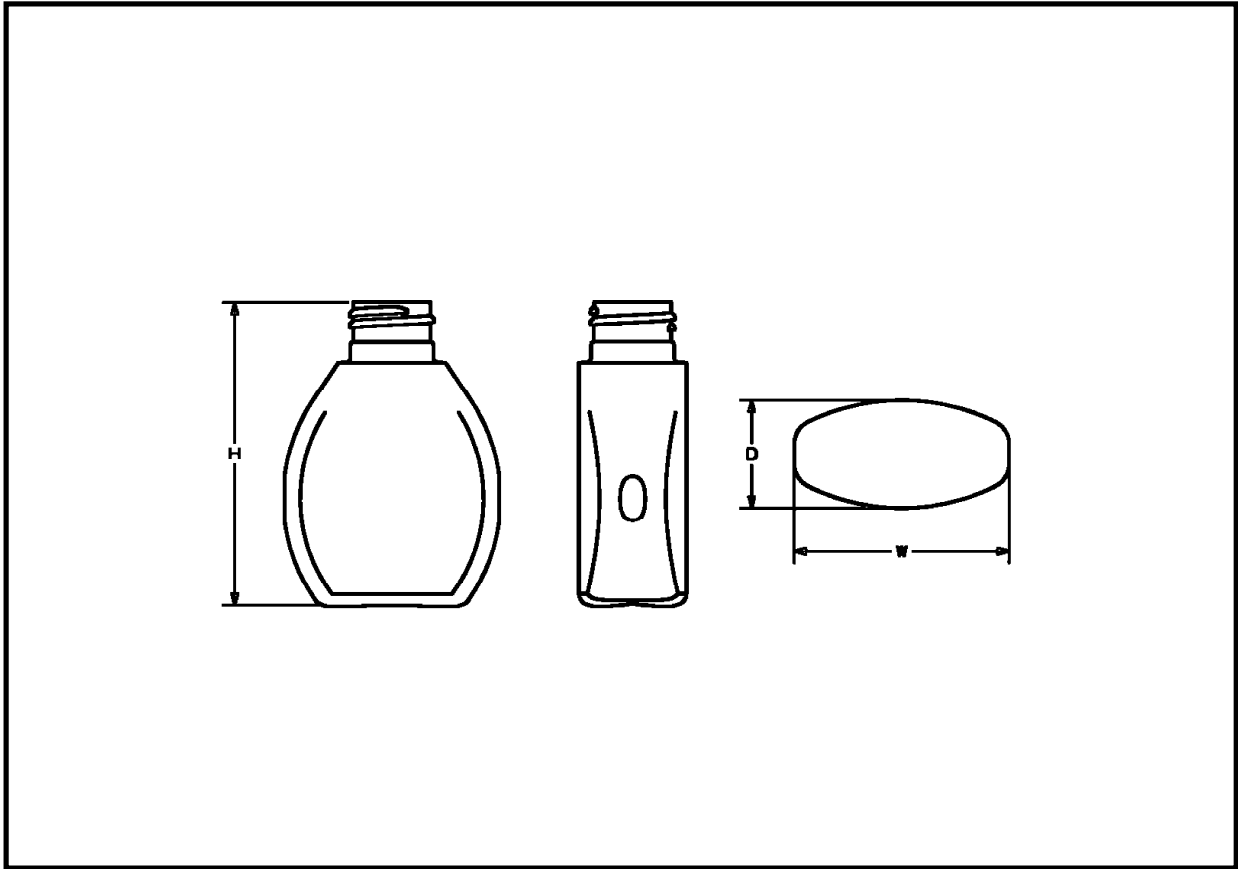

POCKET OVAL

CAPACITY	NECKS	MATERIAL	HEIGHT	WIDTH	DEPTH
1.7 oz	24-410	HDPE	2.835"	1.915"	1.181"
2.7 oz	24-410 Ramp	HDPE	3.341"	2.362"	1.181"

Some exclusions may apply.

SOFT TAPERED OVALS

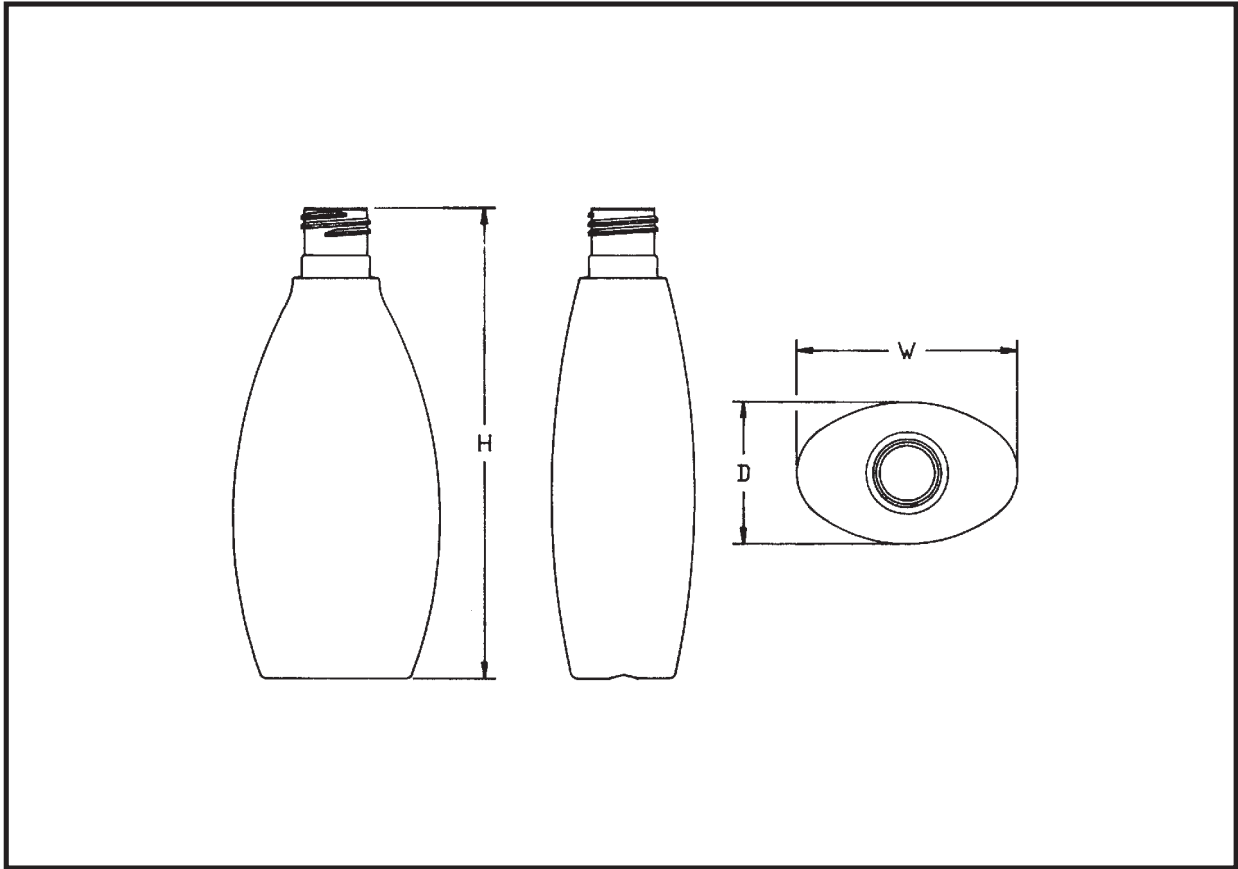

SOFT TAPERED OVALS

CAPACITY	NECKS	MATERIAL	HEIGHT	WIDTH	DEPTH
2 oz	20-410	HDPE	3.885"	1.89"	1.5"
2 oz	20-415	HDPE	4.073"	1.89"	1.5"
4 oz	24-415	HDPE	4.852"	2.108"	1.59"
8 oz	24-415	HDPE	6.434"	2.806"	1.94"
8 oz	24mm*	HDPE	6.434"	2.806"	1.94"

*.920"-.950" H. Mushroom flip top closure is available from Plastic Bottle Corporation.

REVERSE TAPERED OVAL

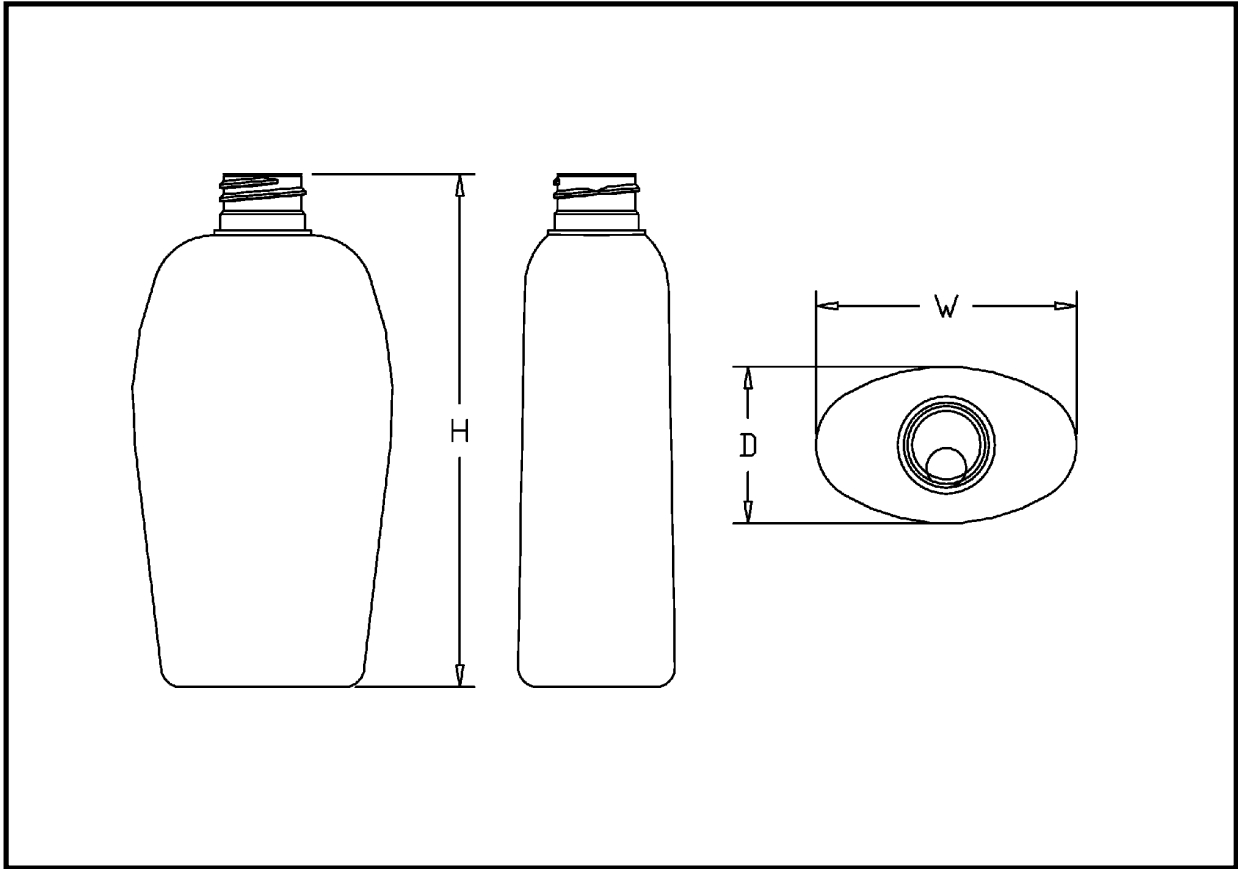

REVERSE TAPERED OVAL

CAPACITY	NECKS	MATERIAL	HEIGHT	WIDTH	DEPTH
13.5 oz	28-410	HDPE	6.5"	3.3"	1.985"

PARISIAN OVAL

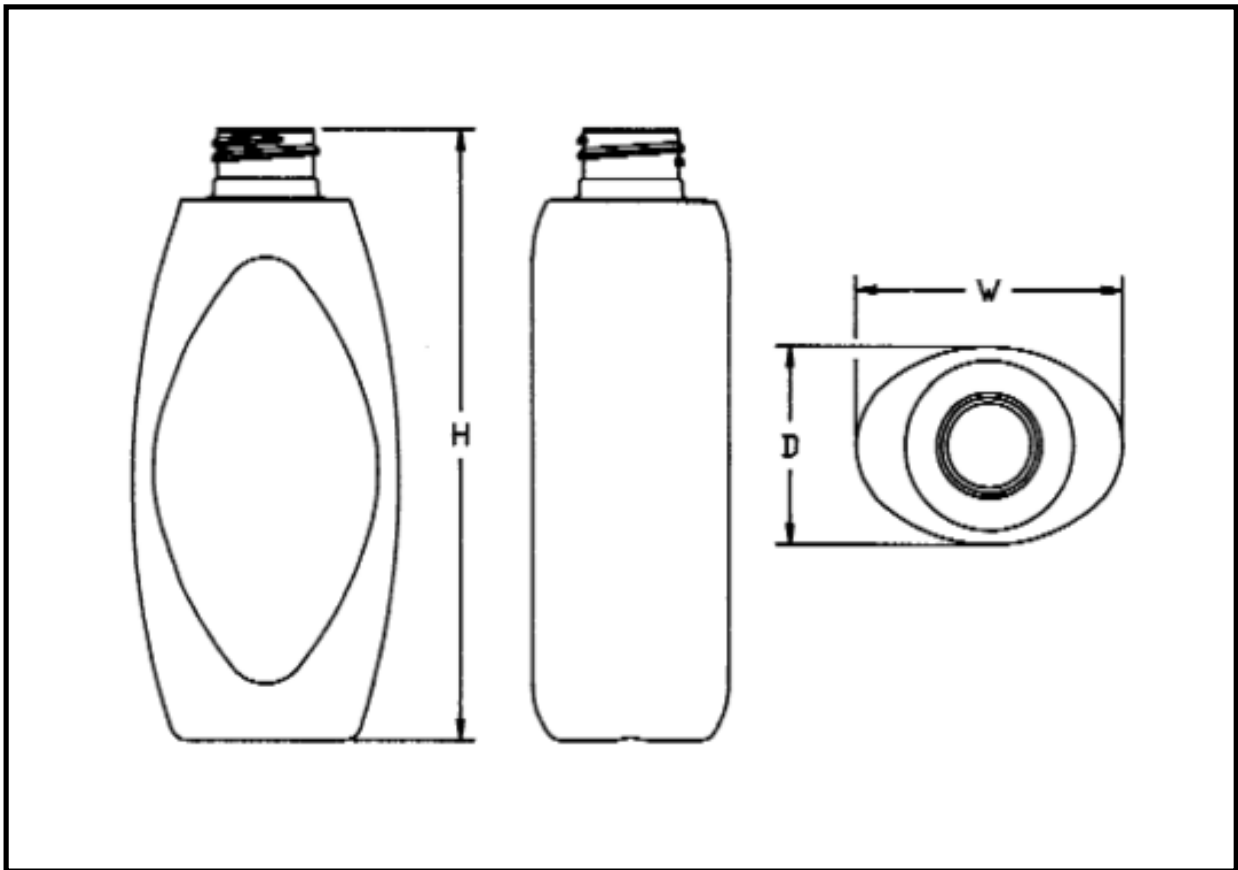

PARISIAN OVAL

CAPACITY	NECKS	MATERIAL	HEIGHT	WIDTH	DEPTH
6 oz	1.5" 22-400 Zeller Closure Reference #1118	HDPE	5.38"	2.38"	1.75"
6 oz	24-410	HDPE	5.46"	2.38"	1.75"

OCULAR OVAL

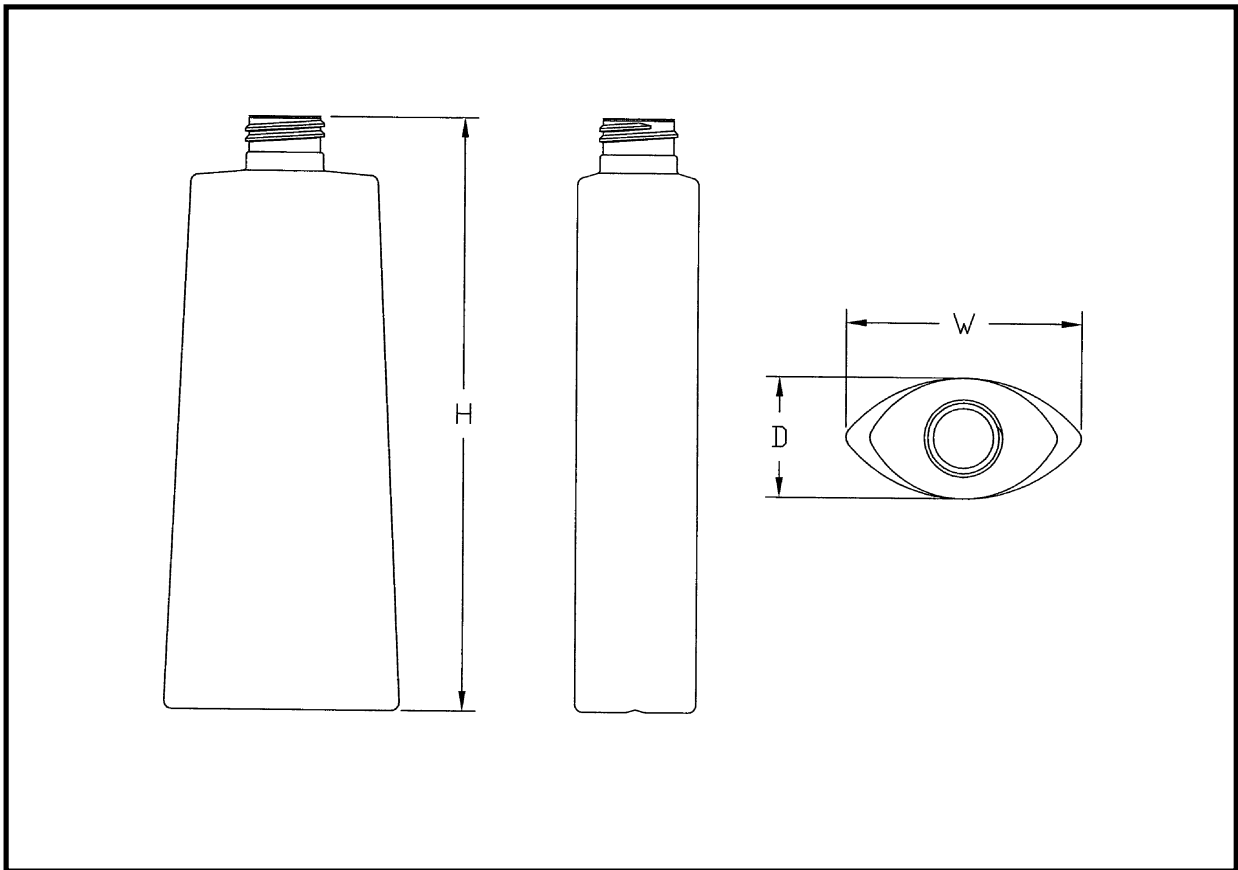

OCULAR OVAL

CAPACITY	NECKS	MATERIAL	HEIGHT	WIDTH	DEPTH
8 oz	24-410	HDPE	7.133"	2.8"	1.452"

Design Patent #507,185
 Available with or without view stripe.

PINCHED OVAL

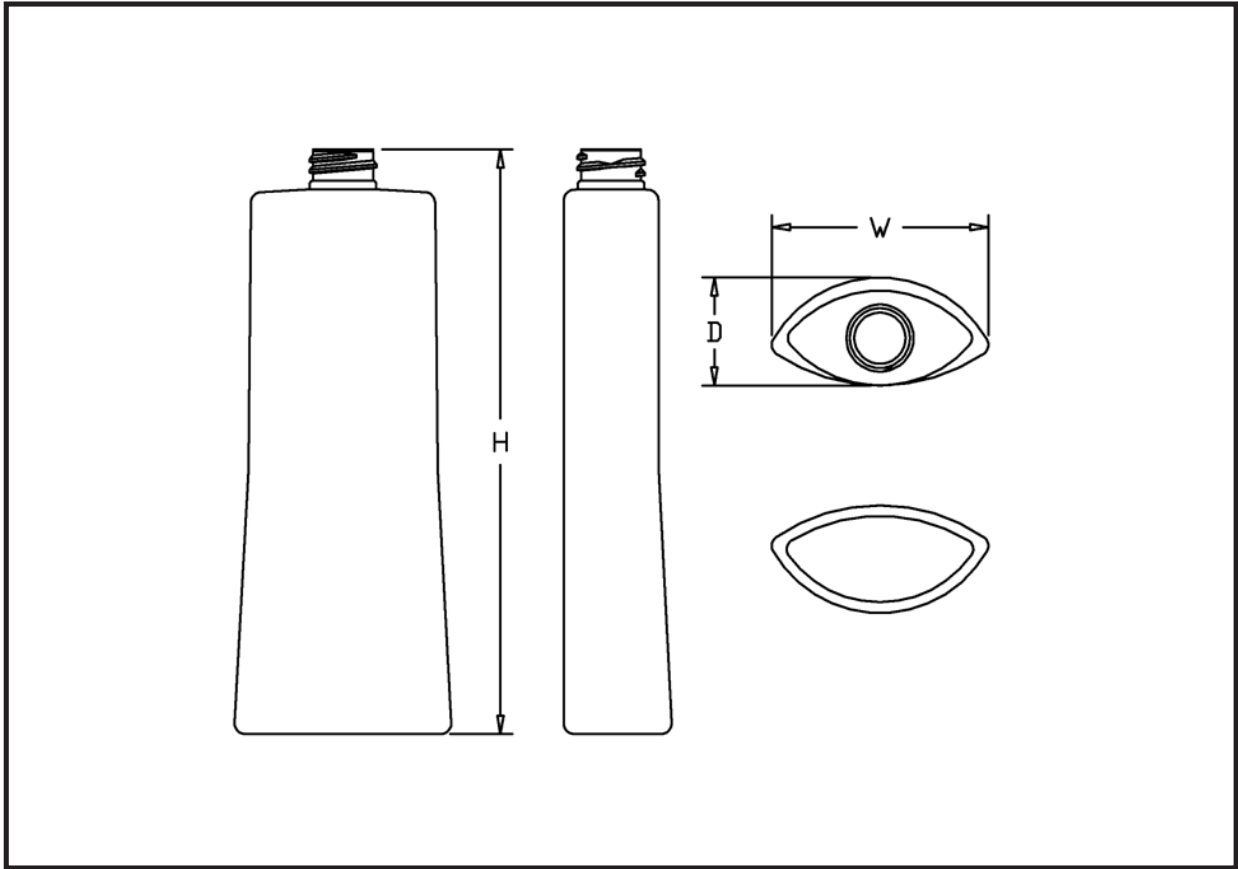

PINCHED OVAL

CAPACITY	NECKS	MATERIAL	HEIGHT	WIDTH	DEPTH
12 oz	24-410	HDPE	8.681"	3.25"	1.8"

EMPRESS OVAL

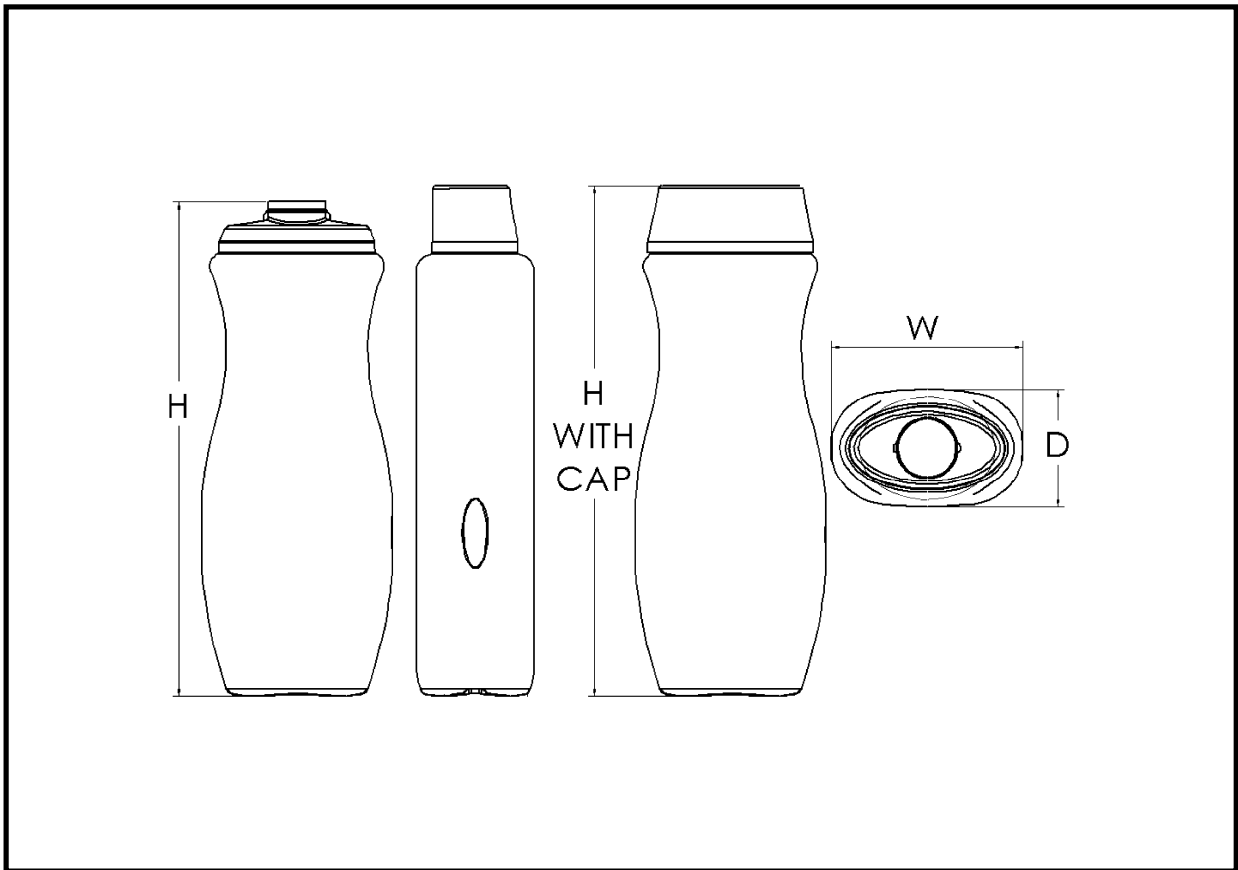

EMPRESS OVAL

CAPACITY	NECKS	MATERIAL	HEIGHT	WIDTH	DEPTH
22 oz	28mm Snap-On	HDPE	9.07"	3.50"	2.234"

Snap-On Closure is available from Plastic Bottle Corporation
 Some exclusions apply

NEW VIENNA OVAL

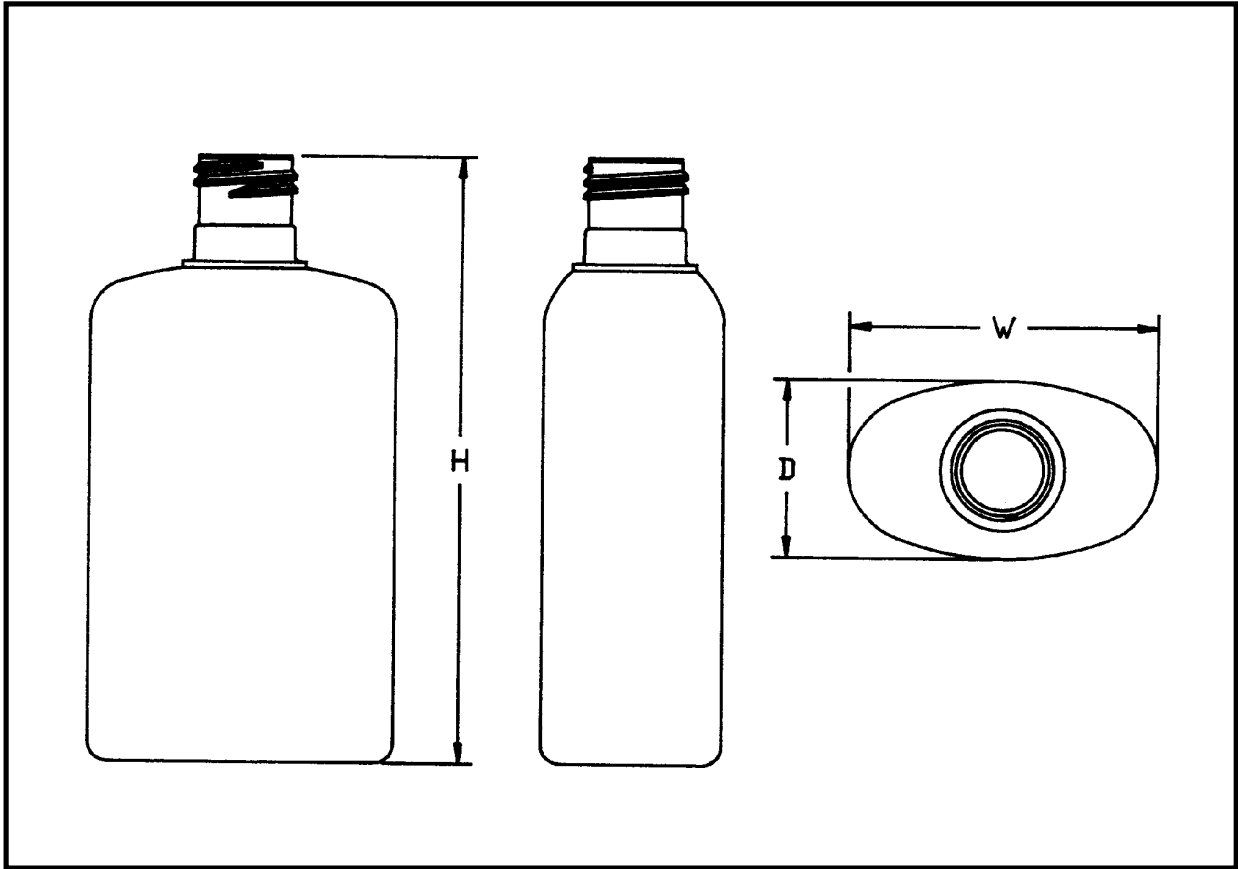

NEW VIENNA OVAL

CAPACITY	NECKS	MATERIAL	HEIGHT	WIDTH	DEPTH
8 oz	24-410	PVC	5.32"	2.79"	1.65"
8 oz	24-415	PVC	5.62"	2.79"	1.65"

For a 50,000 piece order, we could look at building an OPET version.

SYMPHONY OVAL

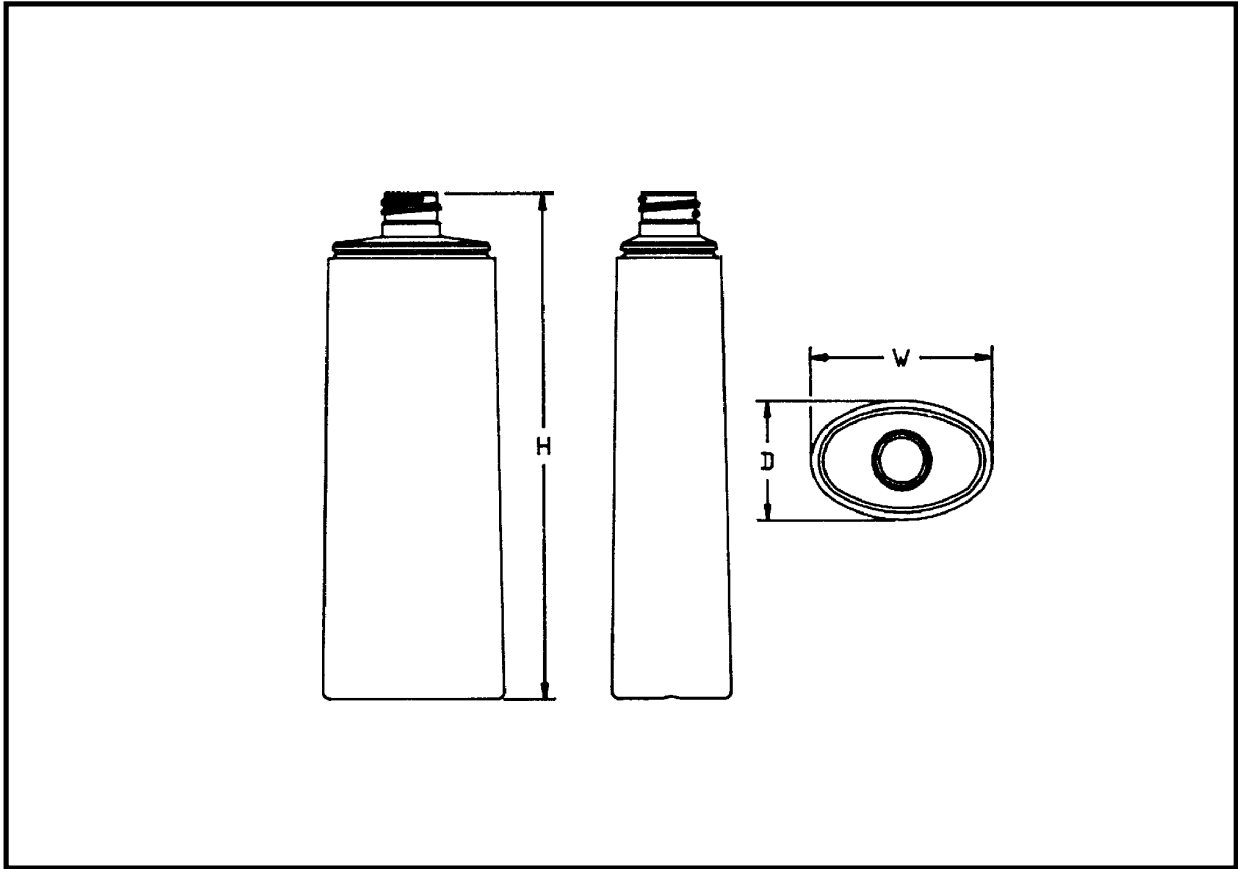

SYMPHONY OVAL

CAPACITY	NECKS	MATERIAL	HEIGHT	WIDTH	DEPTH
8 oz	20-410	HDPE	6.705"	2.432"	1.612"

5th AVENUE OVALS

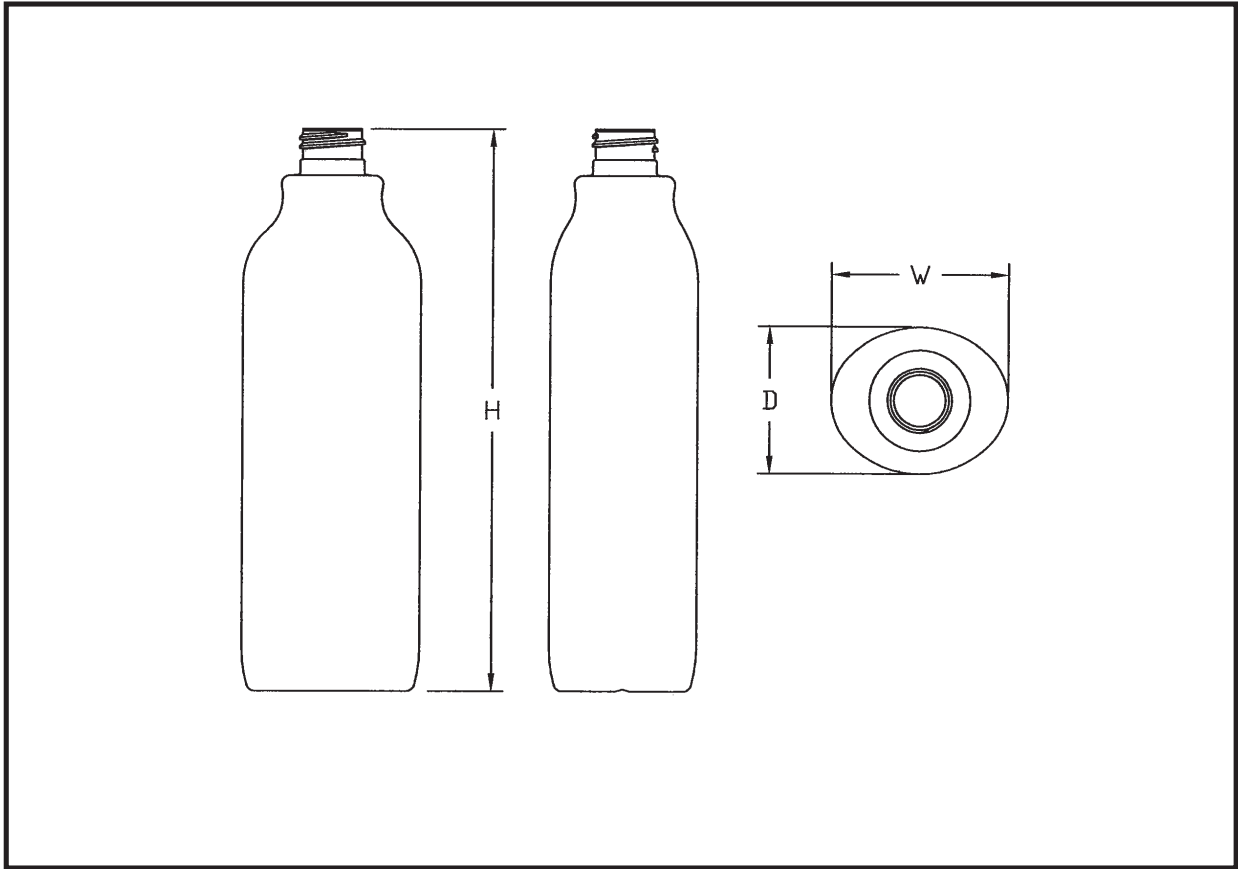

5th AVENUE OVALS

CAPACITY	NECKS	MATERIAL	HEIGHT	WIDTH	DEPTH
400 ml	24-410	OPET	7.75"	2.55"	2.126"
400 ml	24-415	OPET	8.061"	2.55"	2.126"

VENETIAN OVALS

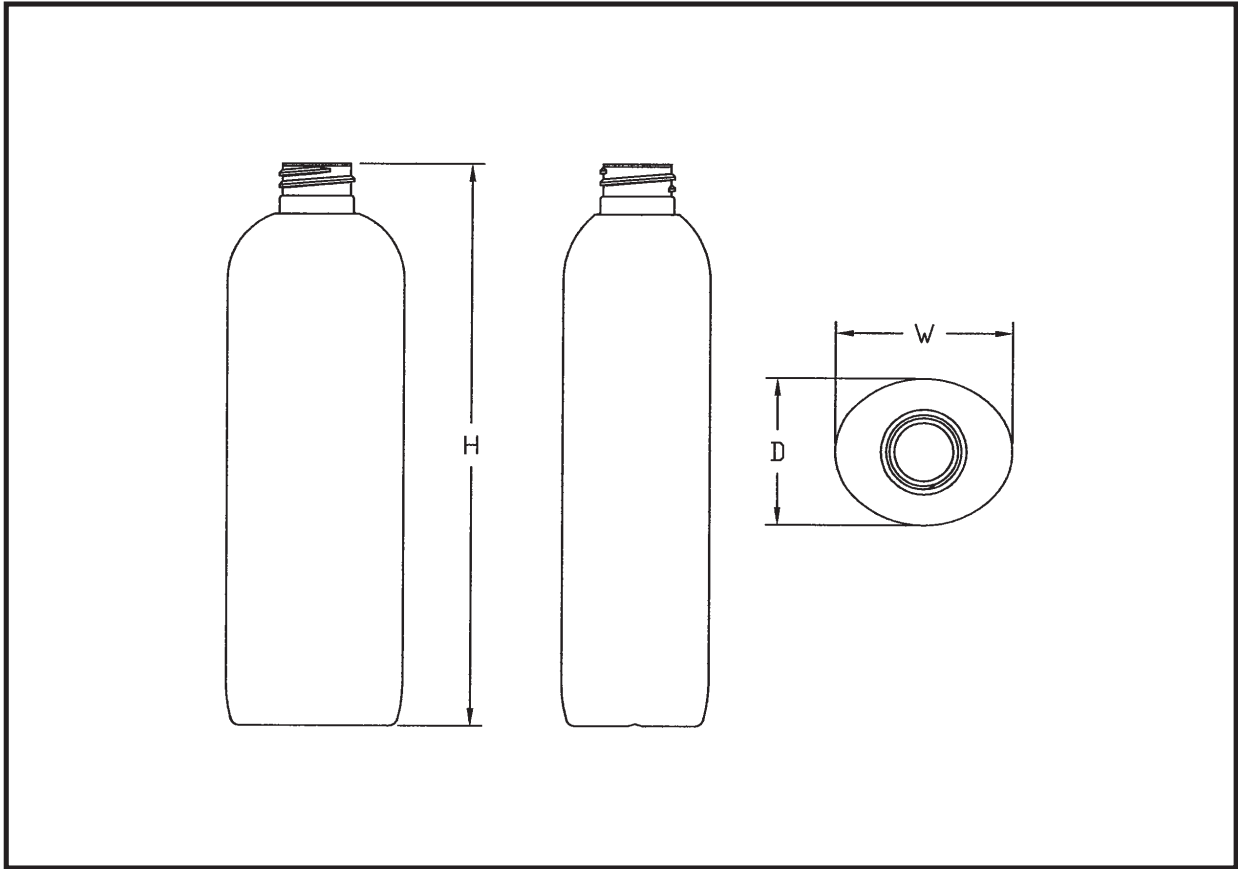

VENETIAN OVALS

CAPACITY	NECKS	MATERIAL	HEIGHT	WIDTH	DEPTH
15 oz	24-410	OPET	7.75"	2.55"	2.126"
15 oz	24-415	OPET	8.061"	2.55"	2.126"

SERENITY(R) OVAL

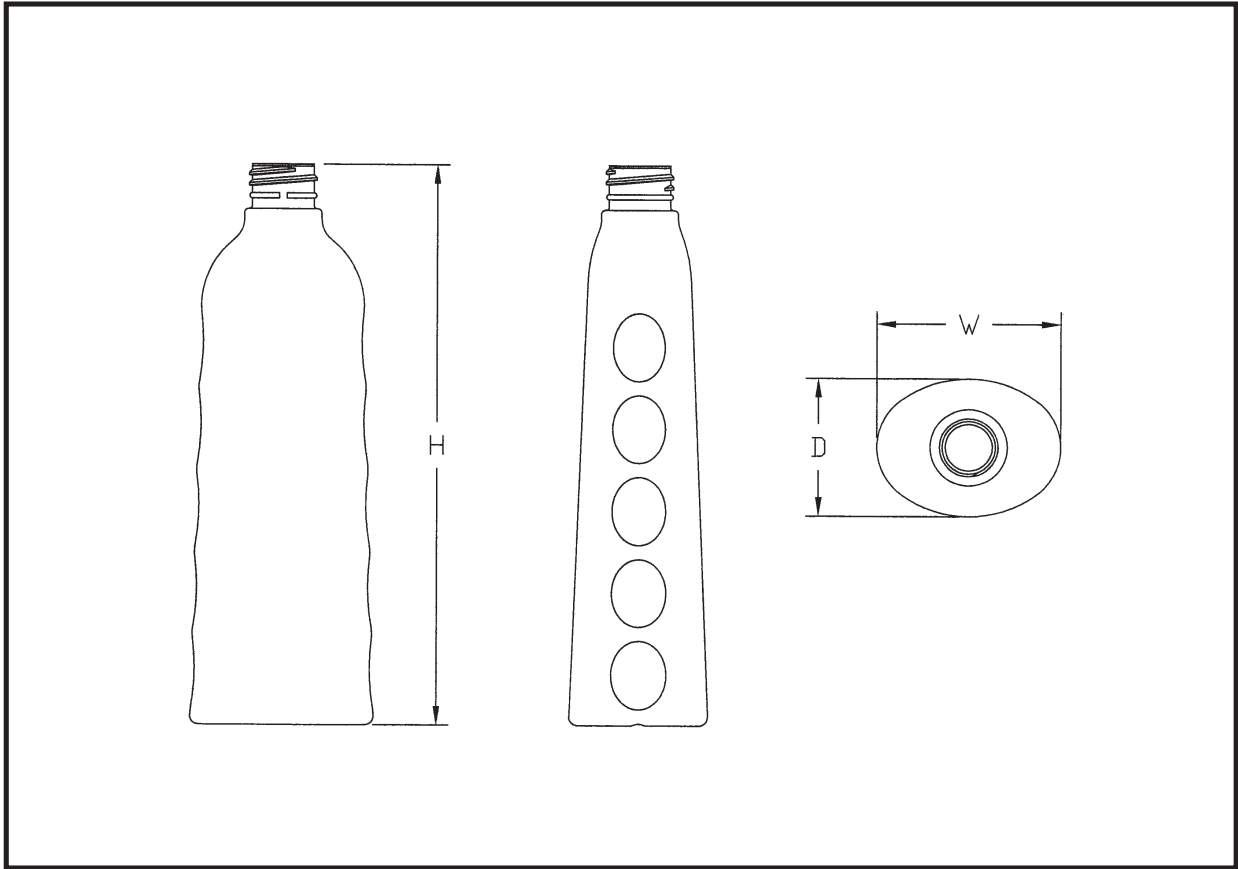

SERENITY(R) OVAL

CAPACITY	NECKS	MATERIAL	HEIGHT	WIDTH	DEPTH
14 oz	28-410	OPET	8.55"	2.769"	2.10"
14 oz	28-415	OPET	8.924"	2.769"	2.10"

Design Patent #D567,662
 Please inquire for other sizes.

PISTOL GRIPPER SPRAYER OVALS

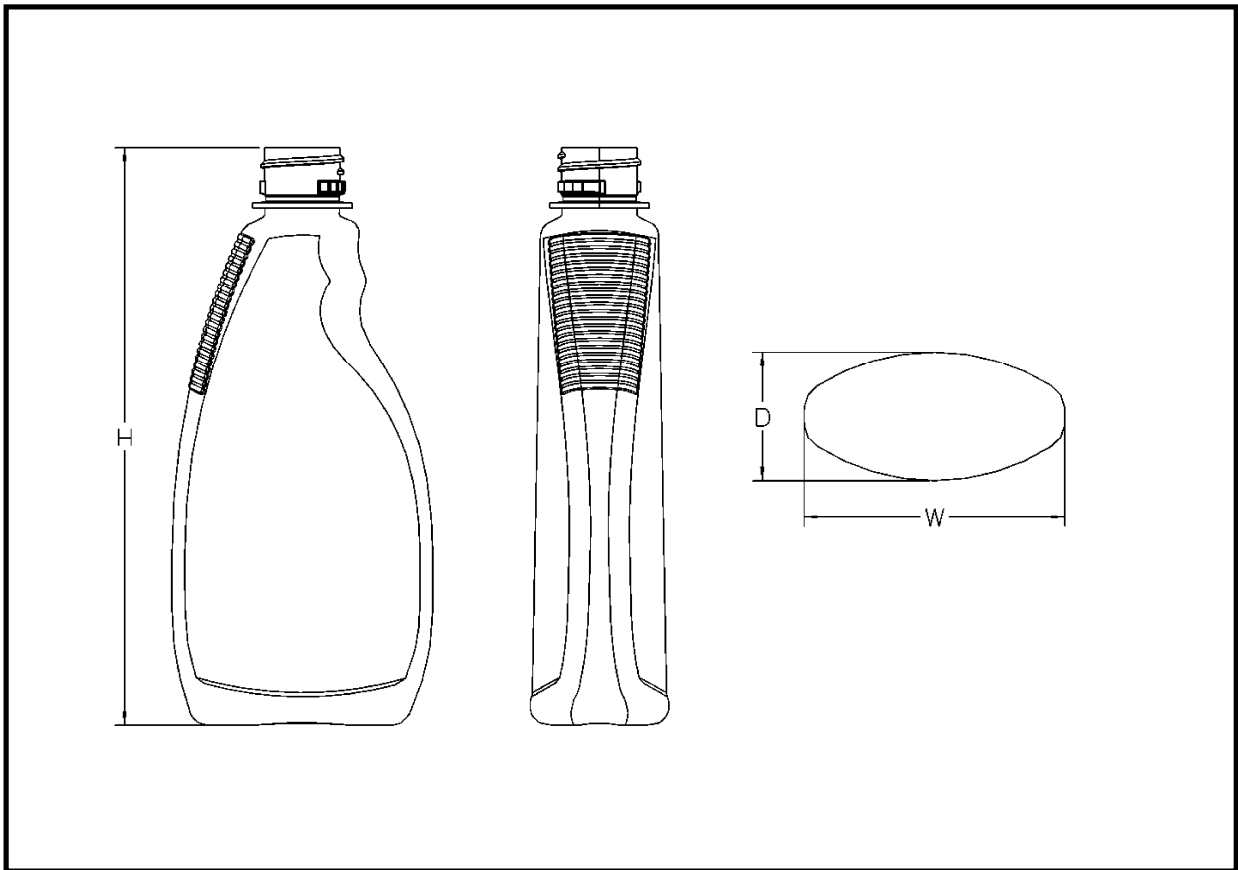

PISTOL GRIPPER SPRAYER OVALS

CAPACITY	NECKS	MATERIAL	HEIGHT	WIDTH	DEPTH
12 oz / 350 ml	28mm Ratchet	OPET	7.532"	3.4"	1.805"

PISTOL GRIPPER SPRAYER OVAL

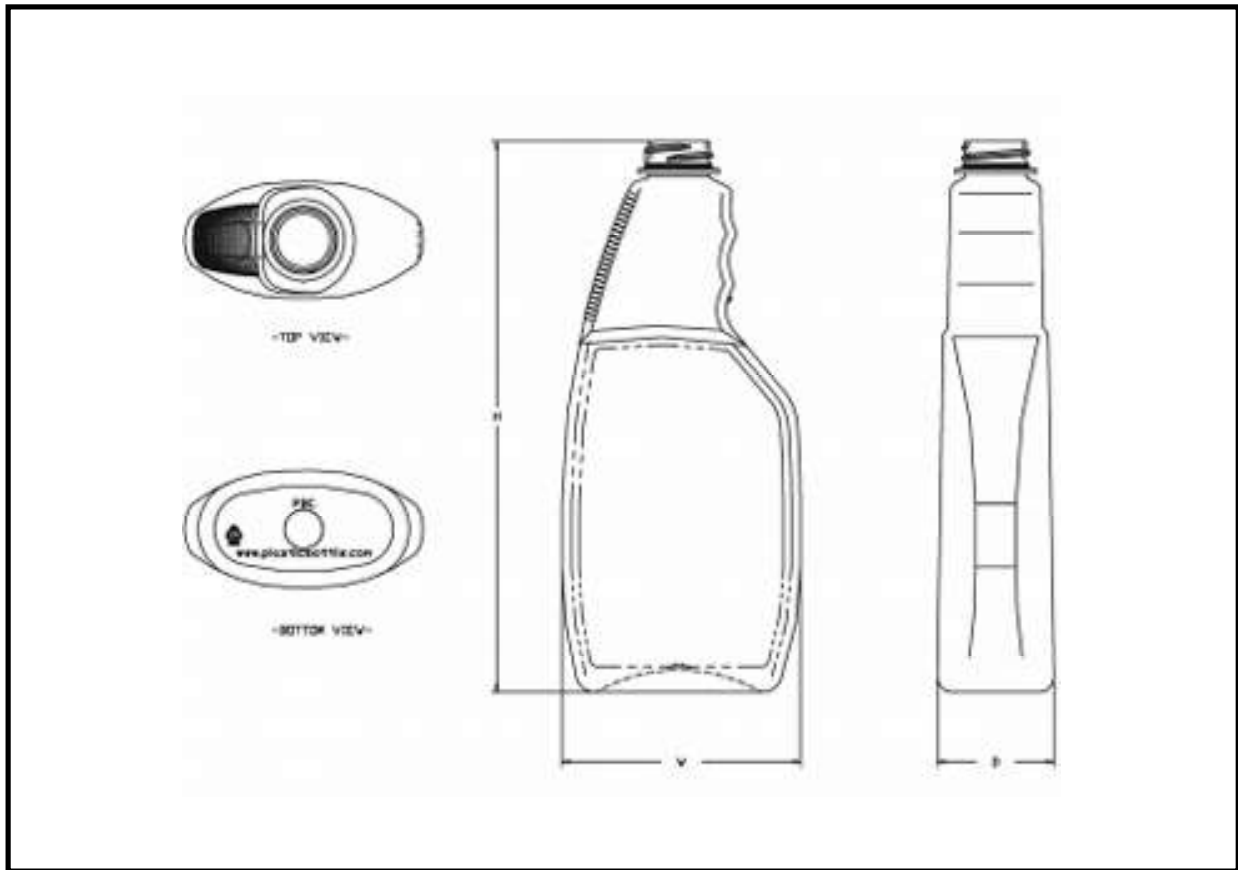

PISTOL GRIPPER SPRAYER OVAL

CAPACITY	NECKS	MATERIAL	HEIGHT	WIDTH	DEPTH
16 oz / 500 ml	28-400	OPET	8.783"	3.797"	1.858"
16 oz / 500 ml	28mm Ratchet	OPET	8.975"	3.797"	1.858"

PISTOL GRIPPER SPRAYER OVAL

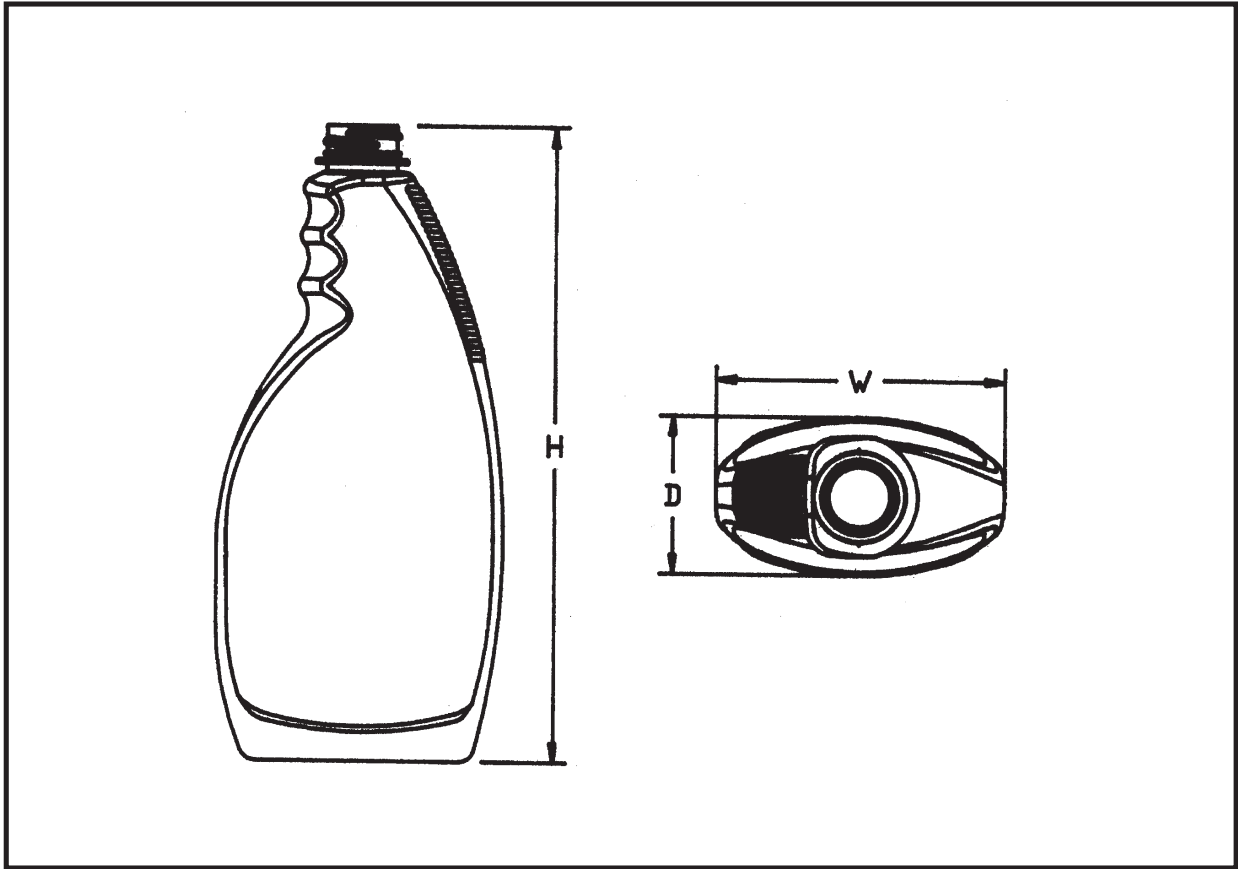

PISTOL GRIPPER SPRAYER OVAL

CAPACITY	NECKS	MATERIAL	HEIGHT	WIDTH	DEPTH
22 oz	28-400 .465"	OPET	9.00"	4.025"	2.25"
22 oz	28mm Ratchet	OPET	9.192"	4.025"	2.25"

PISTOL GRIPPER SPRAYER OVALS

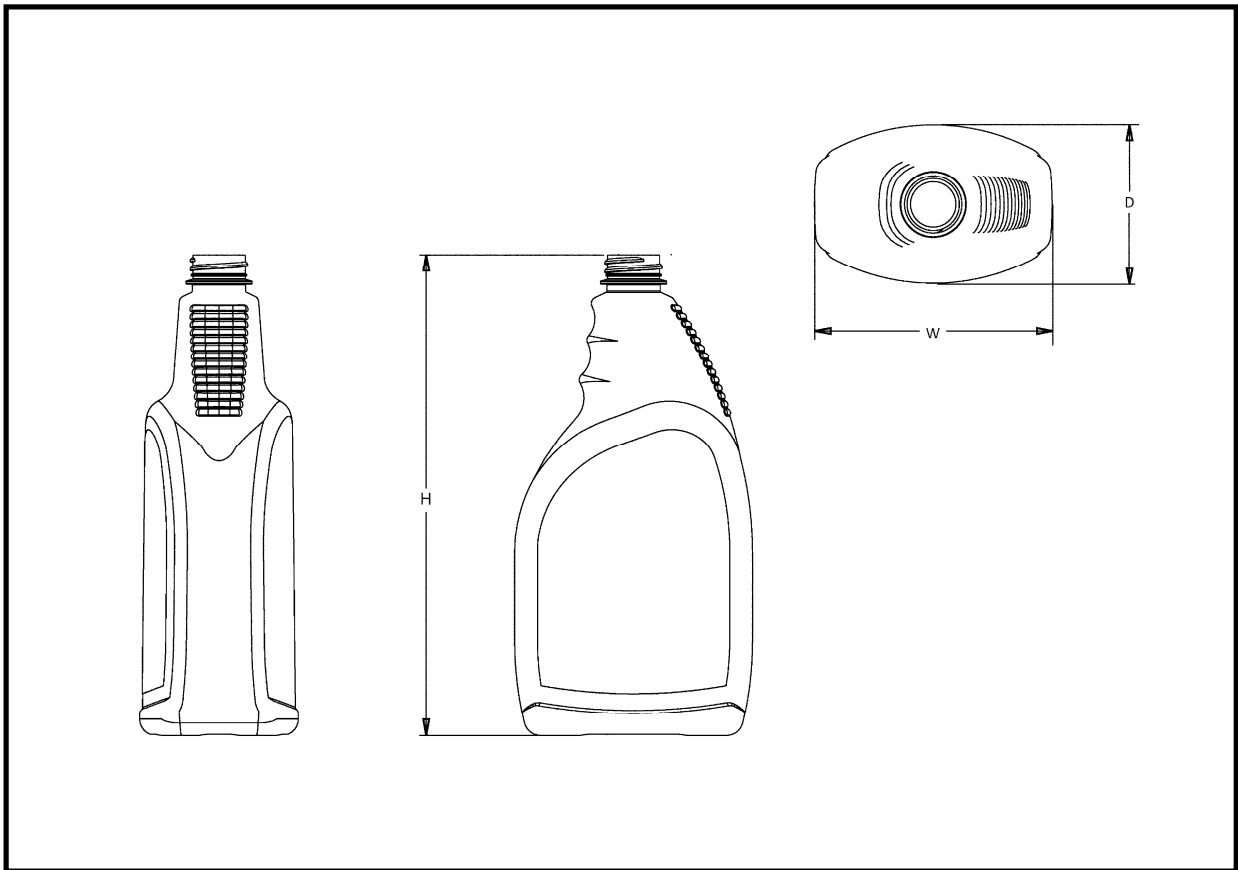

PISTOL GRIPPER SPRAYER OVALS

CAPACITY	NECKS	MATERIAL	HEIGHT	WIDTH	DEPTH
26 oz	28-400	OPET	8.97"	4.275"	2.49"
32 oz / 1 Liter	28-400	OPET	9.041"	4.465"	2.98"

RINGED GRIP SPRAYER OVAL

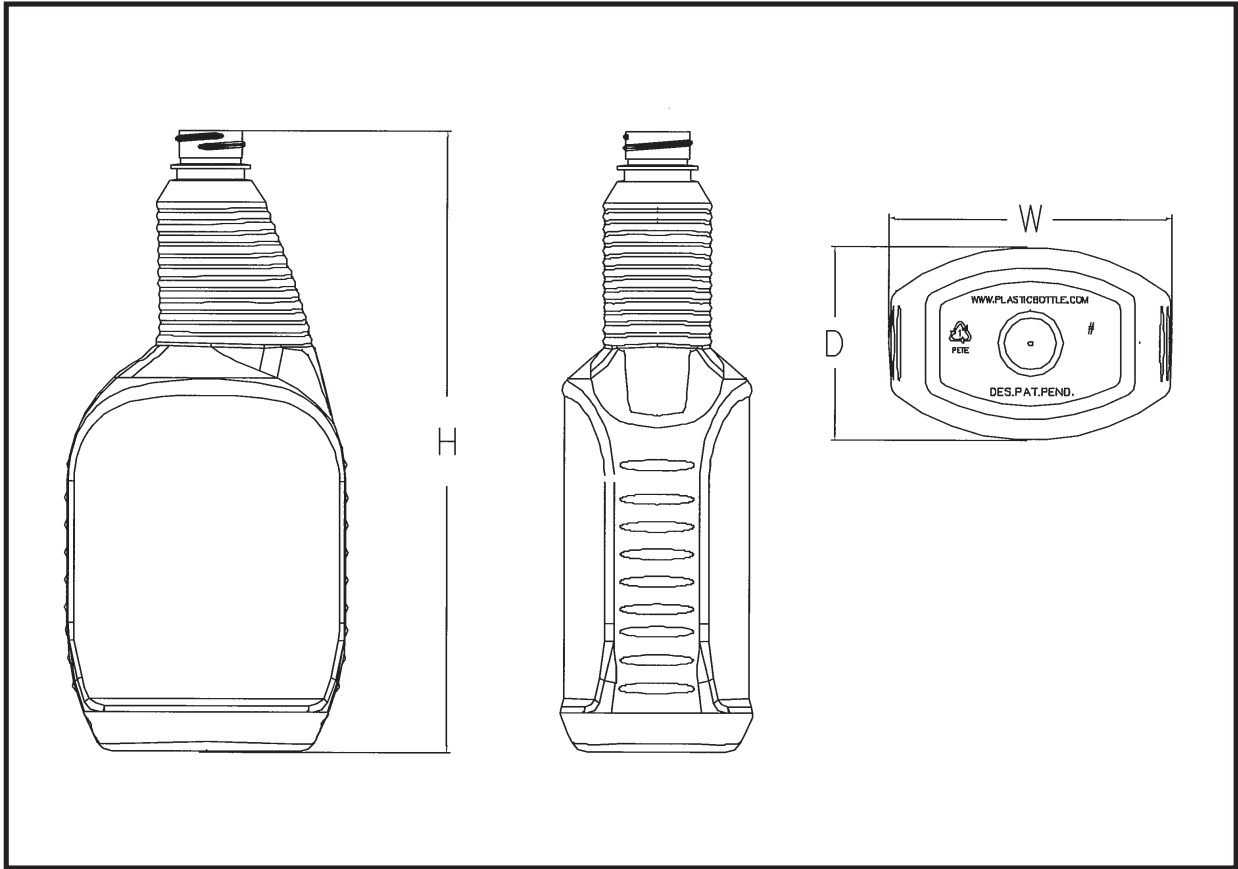

RINGED GRIP SPRAYER OVAL

CAPACITY	NECKS	MATERIAL	HEIGHT	WIDTH	DEPTH
32 oz / 1 Liter	28-400	OPET	9.62"	4.363"	3.02"
32 oz / 1 Liter	28mm Ratchet	OPET	9.812"	4.363"	3.02"

Design Patent #551,981

ROUNDED PISTOL GRIP SPRAYER OVAL

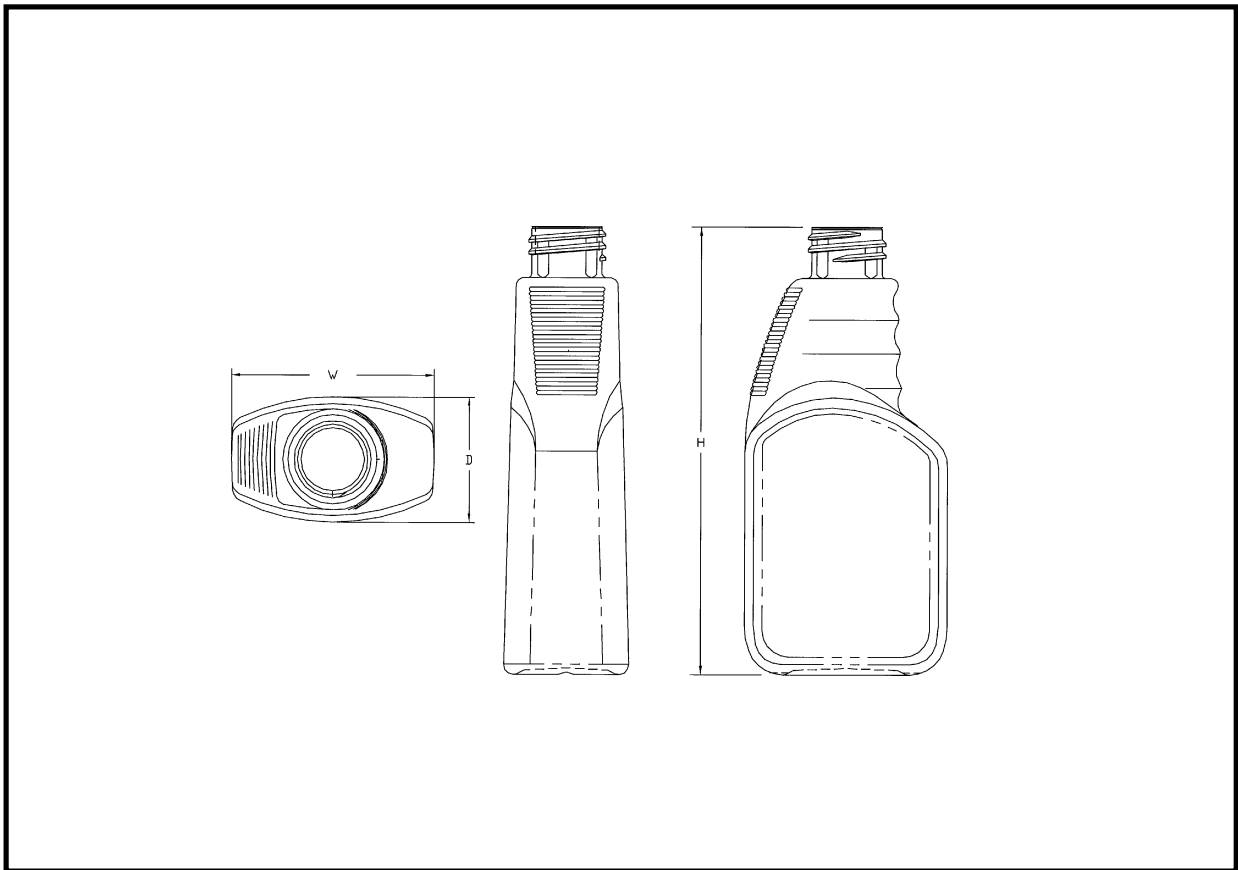

ROUNDED PISTOL GRIP SPRAYER OVAL

CAPACITY	NECKS	MATERIAL	HEIGHT	WIDTH	DEPTH
8 oz / 250 ml	28-400 Ramp	HDPE	5.978"	2.834"	1.75"
8 oz / 250 ml	28-410 Ramp	HDPE	6.25"	2.834"	1.75"
8 oz / 250 ml	28mm WestRock Ratchet*	HDPE	6.224"	2.834"	1.75"

*Use with WestRock Ratchet Trigger Sprayer.

ROUNDED PISTOL GRIP SPRAYER OVALS

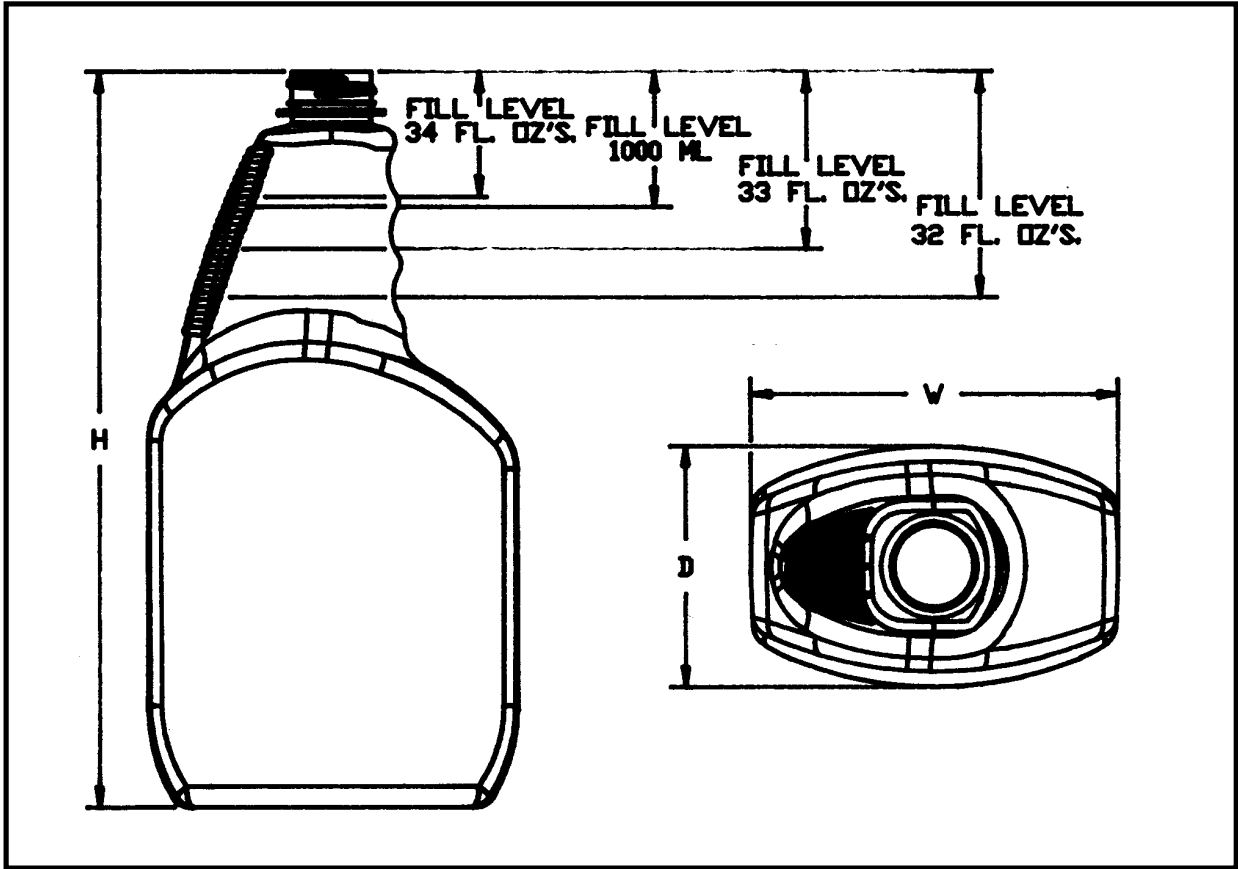

ROUNDED PISTOL GRIP SPRAYER OVALS

CAPACITY	NECKS	MATERIAL	HEIGHT	WIDTH	DEPTH
32 oz / 1 Liter	28-400	OPET	9.10"	4.50"	3.00"
32 oz / 1 Liter	28mm Ratchet	OPET	9.196"	4.50"	3.00"

ROUNDED PISTOL GRIP SPRAYER OVALS

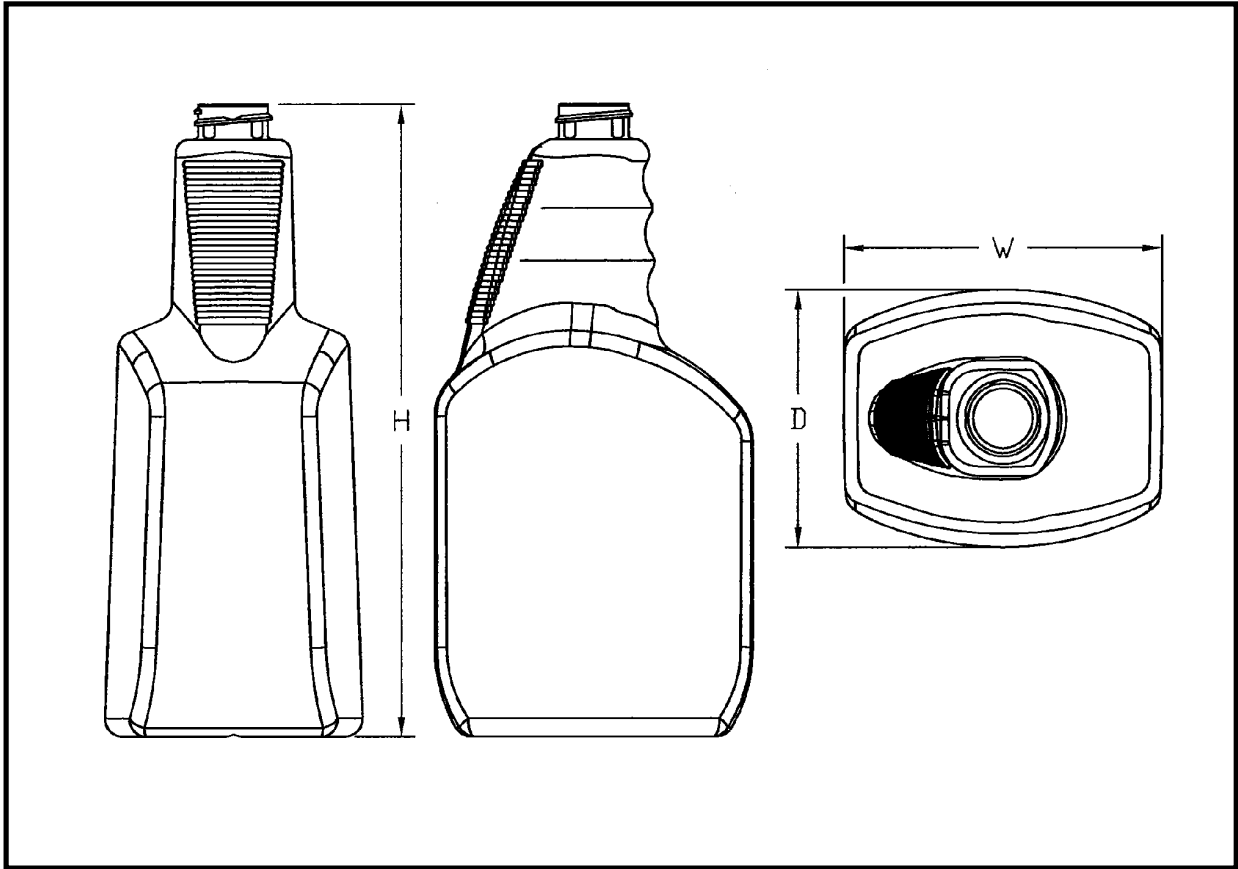

ROUNDED PISTOL GRIP SPRAYER OVALS

CAPACITY	NECKS	MATERIAL	HEIGHT	WIDTH	DEPTH
40 oz	28-400 Ramp	HDPE	8.98"	4.50"	3.636"
40 oz	28mm Ratchet	HDPE	9.164"	4.50"	3.636"

ROUNDED PISTOL GRIP SPRAYER OVALS

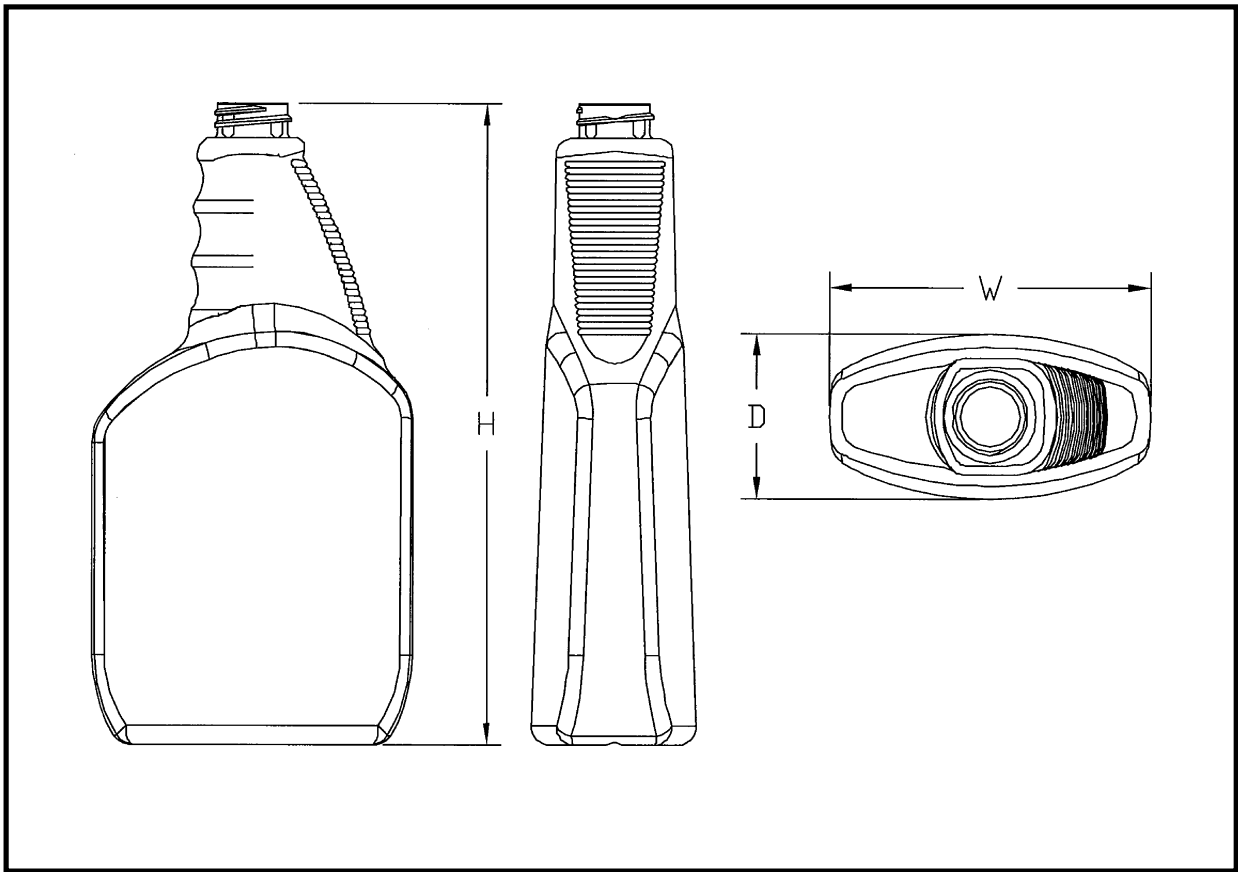

ROUNDED PISTOL GRIP SPRAYER OVALS

CAPACITY	NECKS	MATERIAL	HEIGHT	WIDTH	DEPTH
24 oz	28-400 Ramp	HDPE	8.98"	4.50"	2.32"
24 oz	28mm WestRock Ratchet*	HDPE	9.183"	4.50"	2.32"
24 oz	28mm K2K Hose End Sprayer	HDPE	9.183"	4.50"	2.32"

*Use with WestRock Ratchet Trigger Sprayer.

ROUNDED PISTOL GRIP SPRAYER OVAL

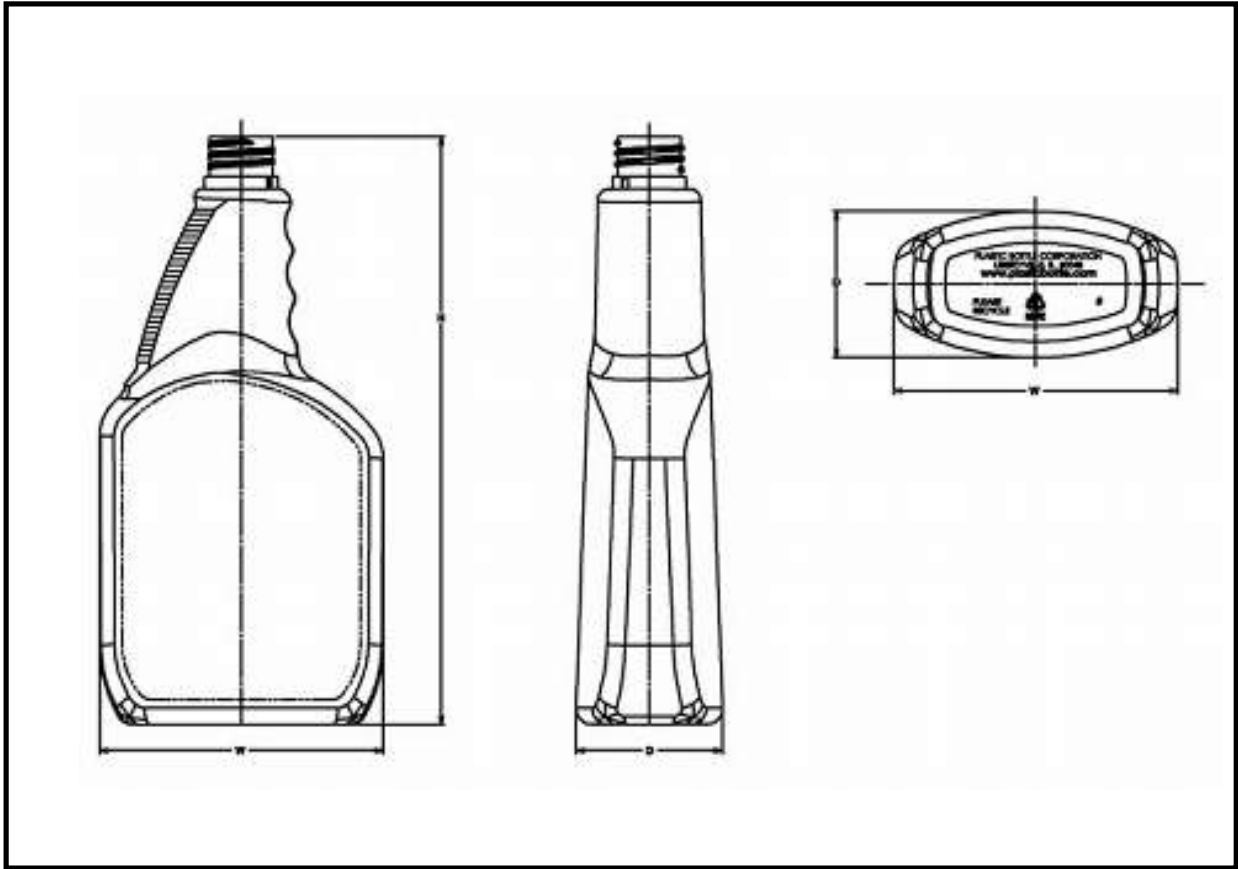

ROUNDED PISTOL GRIP SPRAYER OVAL

CAPACITY	NECKS	MATERIAL	HEIGHT	WIDTH	DEPTH
24 oz	28mm Special HP2/HP3 Hose End	HDPE	9.31"	4.50"	2.32"

Only to be used with the WestRock/MWW/Calmar Hose End Ratcheted Closure.

ORIGINAL PISTOL GRIP SPRAYER OVALS

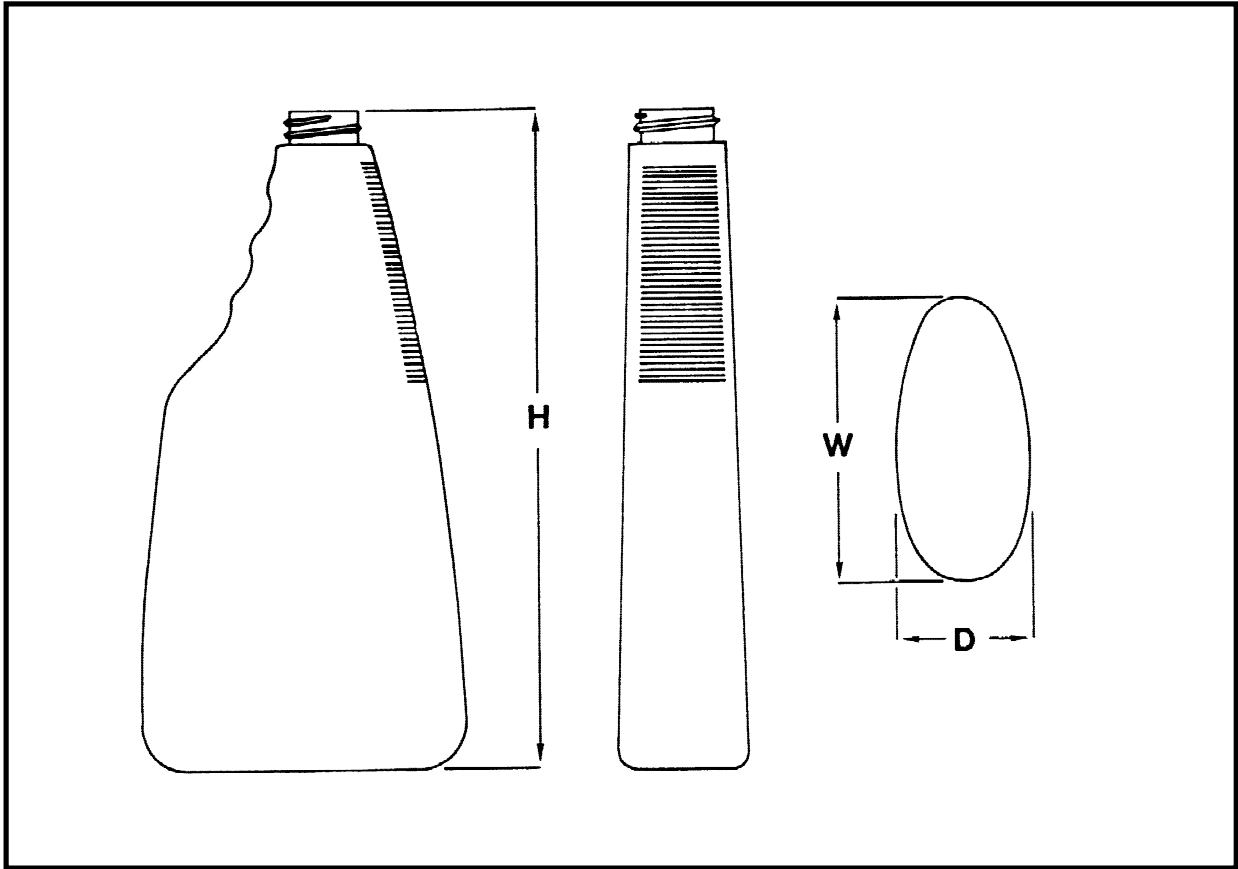

ORIGINAL PISTOL GRIP SPRAYER OVALS

CAPACITY	NECKS	MATERIAL	HEIGHT	WIDTH	DEPTH
20 oz*	28-400 Ramp	PVC	9.02"	4.45"	2.06"
22 oz	28-400 Ramp	HDPE	9.36"	4.45"	2.35"

*For a 50,000 piece order, we could look at building an OPET version.

ORIGINAL PISTOL GRIP SPRAYER OVALS

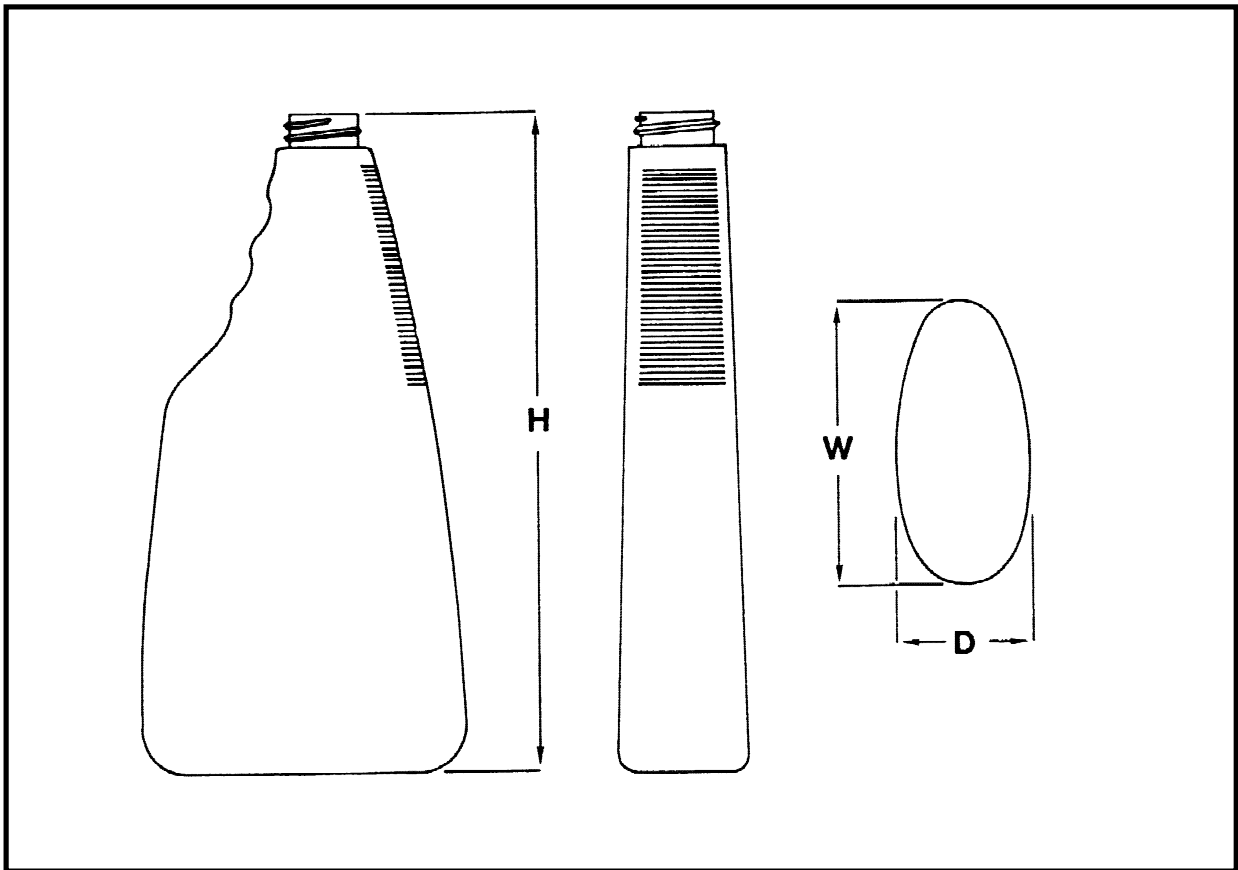

ORIGINAL PISTOL GRIP SPRAYER OVALS

CAPACITY	NECKS	MATERIAL	HEIGHT	WIDTH	DEPTH
27 oz / 800 ml	28-400 Ramp	PVC	9.00"	5.03"	2.60"
27 oz / 800 ml	28mm Anti-Rotational	PVC	9.00"	5.03"	2.60"

For a 50,000 piece order, we could look at building an OPET version.

SUNNY TWIST GRIP(R) SPRAYER OVAL

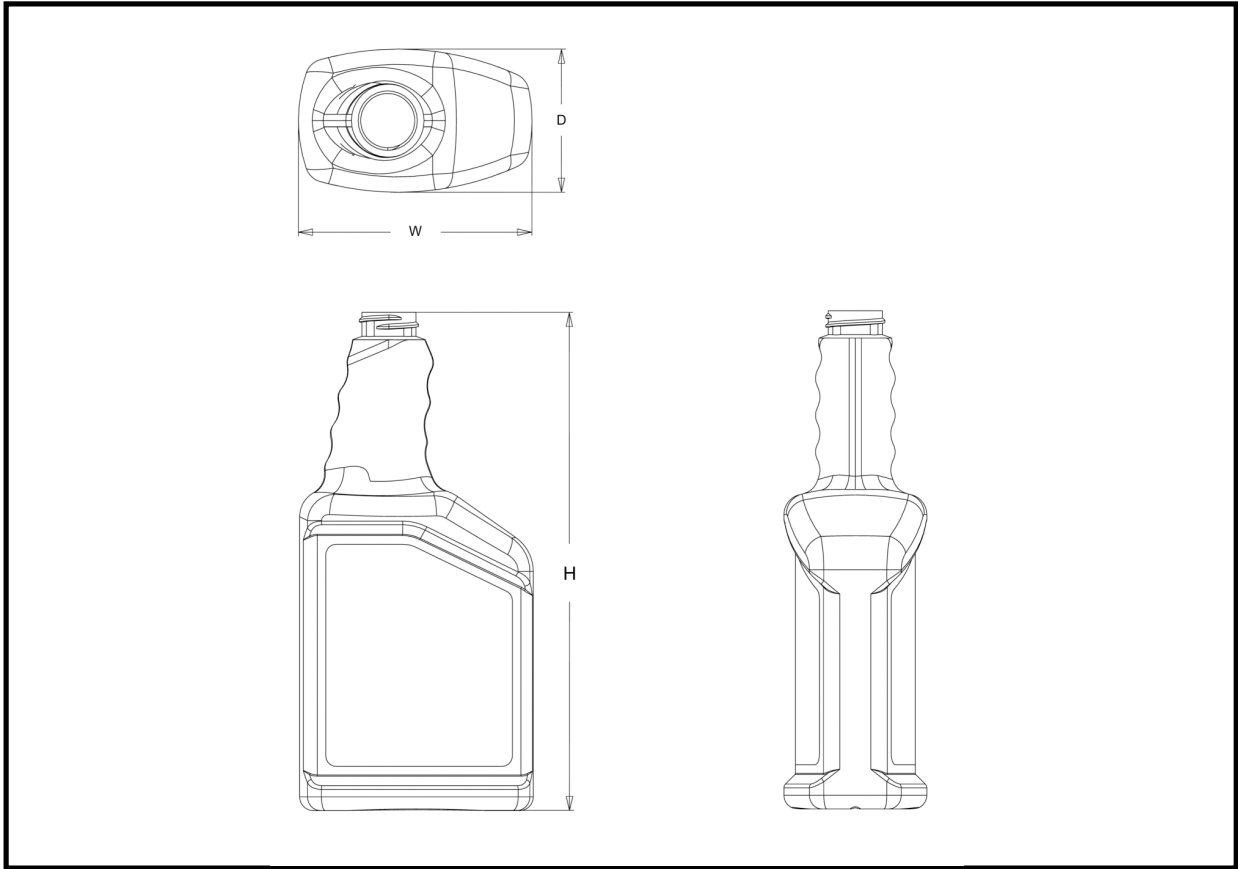

SUNNY TWIST GRIP(R) SPRAYER OVAL

CAPACITY	NECKS	MATERIAL	HEIGHT	WIDTH	DEPTH
24 oz / 750 ml	28-400	HDPE	9.038"	4.25"	2.18"

TWIST GRIP® SPRAYER OVALS

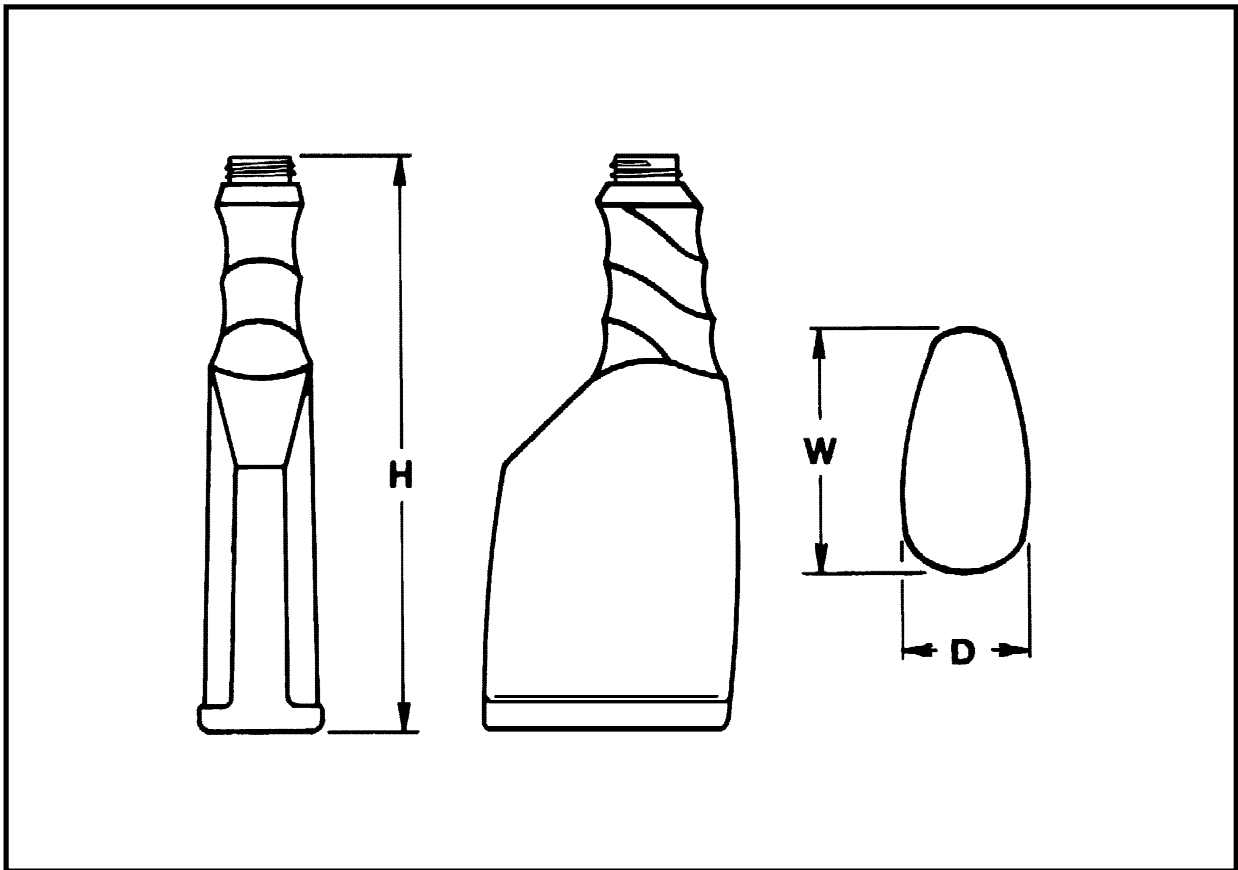

TWIST GRIP® SPRAYER OVALS

CAPACITY	NECKS	MATERIAL	HEIGHT	WIDTH	DEPTH
17 oz / 500 ml	28-400 Ramp .440H	HDPE	8.98"	3.86"	2.06"
17 oz / 500 ml	28mm Ratchet	HDPE	9.282"	3.86"	2.06"
24 oz	28-400 Ramp	HDPE	9.51"	4.37"	2.25"
24 oz	28-400	OPET	9.403"	4.25"	2.21"
24 oz	28mm 4Rat WTB*	OPET	9.45"	4.25"	2.21"
24 oz	28mm 8Rat WSR**	OPET	9.595"	4.25"	2.21"

* WTB is with Transfer Bead

** WSR is with Support Ring

Design patent #345,917.

Where great ideas take shape.

METRO SPRAYER OVAL

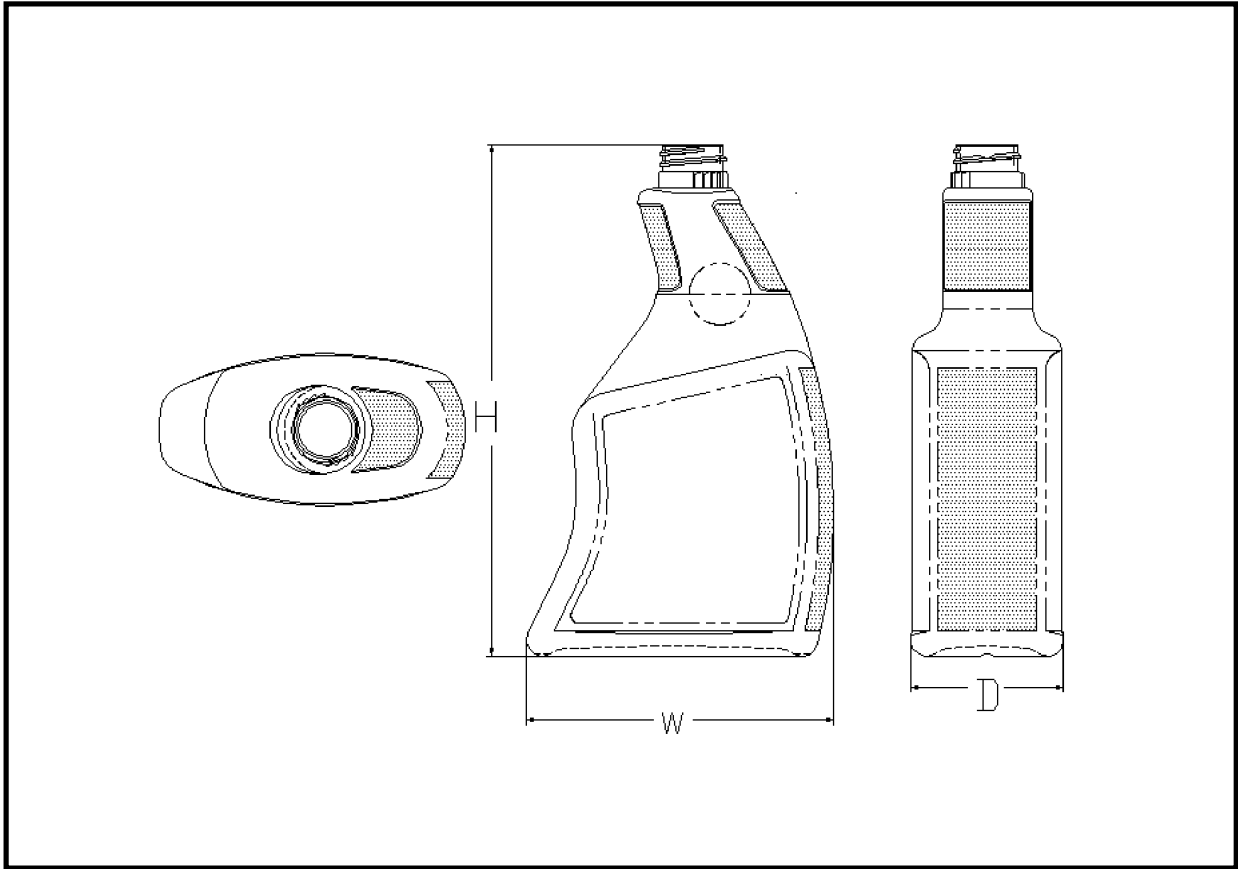

METRO SPRAYER OVAL

CAPACITY	NECKS	MATERIAL	HEIGHT	WIDTH	DEPTH
24 oz	28mm WestRock Ratchet	HDPE	8.335"	5.0"	2.484"

Available with and without custom inserts.
 Use with WestRock Ratchet Trigger Sprayer.

TWIST GRIP® 2000 SPRAYER OVALS

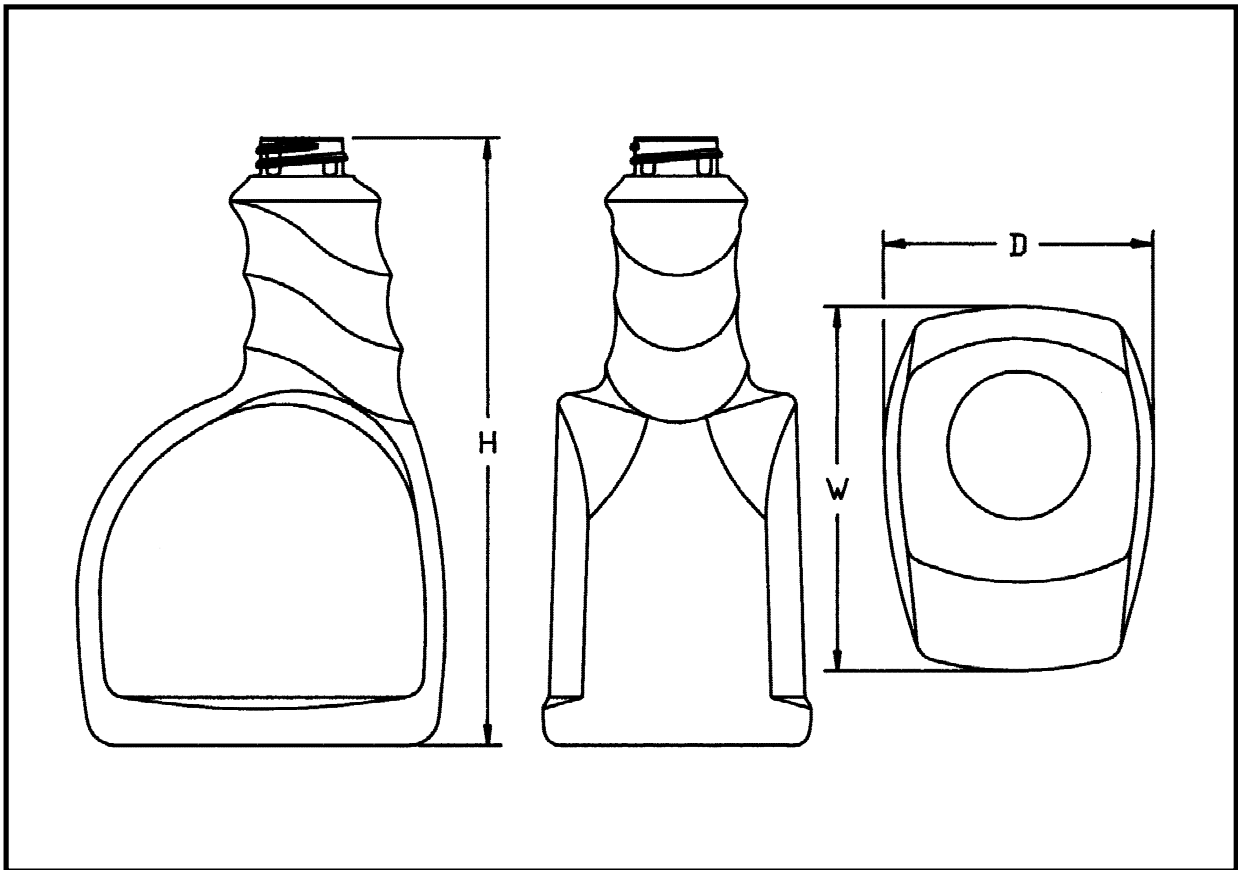

TWIST GRIP® 2000 SPRAYER OVALS

CAPACITY	NECKS	MATERIAL	HEIGHT	WIDTH	DEPTH
16 oz / 500 ml*	28-400 Ramp	HDPE	7.40"	3.608"	2.65"
16 oz / 500 ml	28mm WestRock Ratchet**	HDPE	7.617"	3.608"	2.65"
16 oz / 500 ml	28mm Guala Ratchet	HDPE	7.535"	3.608"	2.65"
24 oz / 750 ml	28-400 Ramp	HDPE	7.40"	4.400"	3.22"
27 oz / 800 ml	28-400 Ramp	HDPE	7.375"	4.426"	3.517"

Design Patented

*Available with and without view stripe

**Use with WestRock Ratchet Trigger Sprayer

TWIST GRIP(R) 2000 SPRAYER OVALS

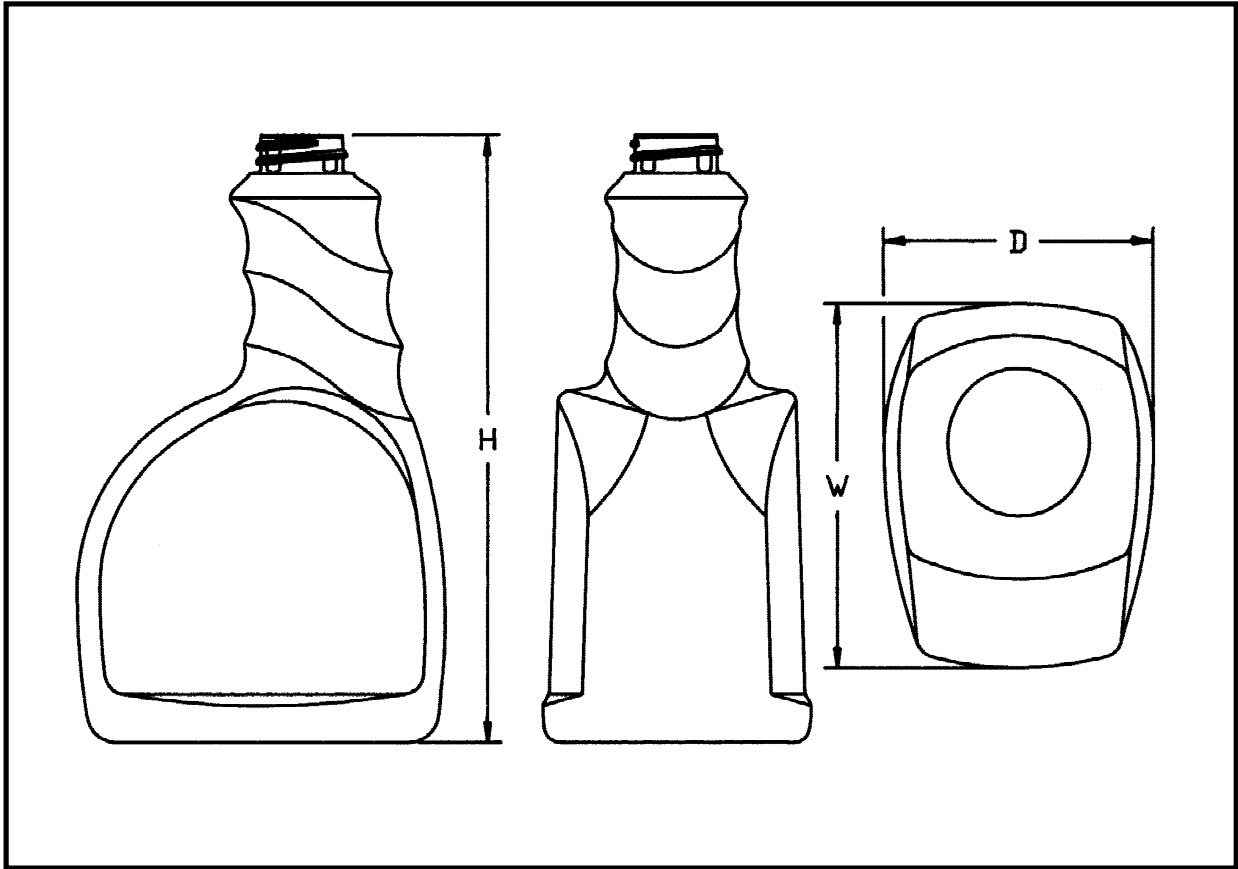

TWIST GRIP(R) 2000 SPRAYER OVALS

CAPACITY	NECKS	MATERIAL	HEIGHT	WIDTH	DEPTH
32 oz / 1 Liter	28-400 Ramp	HDPE	7.40"	4.950"	3.63"

Design Patented

EURO TWIST GRIP^(R) SPRAYER OVALS

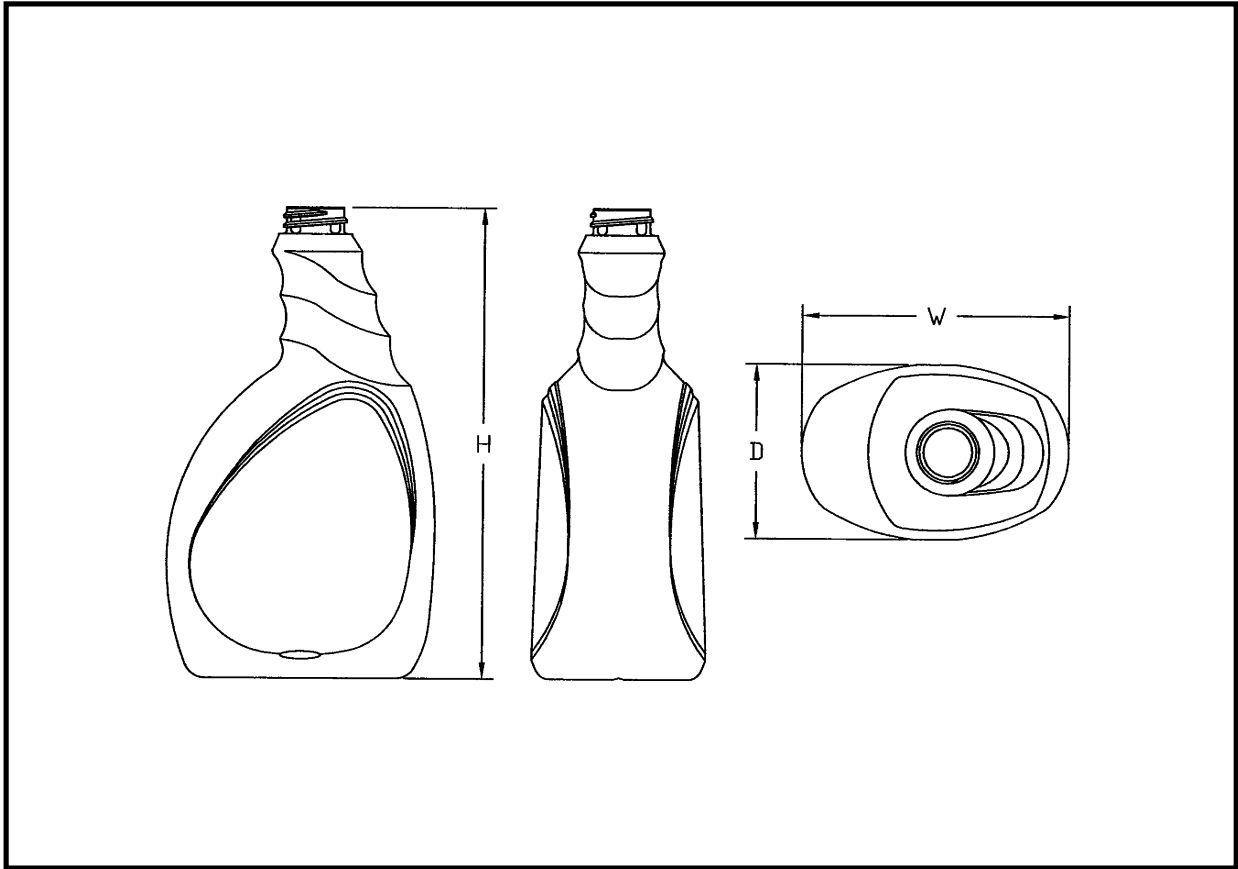

EURO TWIST GRIP^(R) SPRAYER OVALS

CAPACITY	NECKS	MATERIAL	HEIGHT	WIDTH	DEPTH
12 oz*	28-400 Ramp	HDPE	6.505"	3.326"	2.516"
12 oz*	28mm Ratchet	HDPE	6.807"	3.326"	2.516"
16 oz / 500 ml*	28-400 Ramp	HDPE	7.19"	3.706"	2.642"
16 oz / 500 ml*	28mm 6Ratchet	HDPE	7.417"	3.706"	2.642"
16 oz / 500 ml*	28mm 8Ratchet	HDPE	7.417"	3.706"	2.642"
24 oz*	28-400 Ramp	HDPE	8.13"	4.08"	2.988"

Design Patent # US D548,093 S
 *Available with or without view stripe
 Other sizes available upon request

EURO TWIST GRIP^(R) SPRAYER OVALS

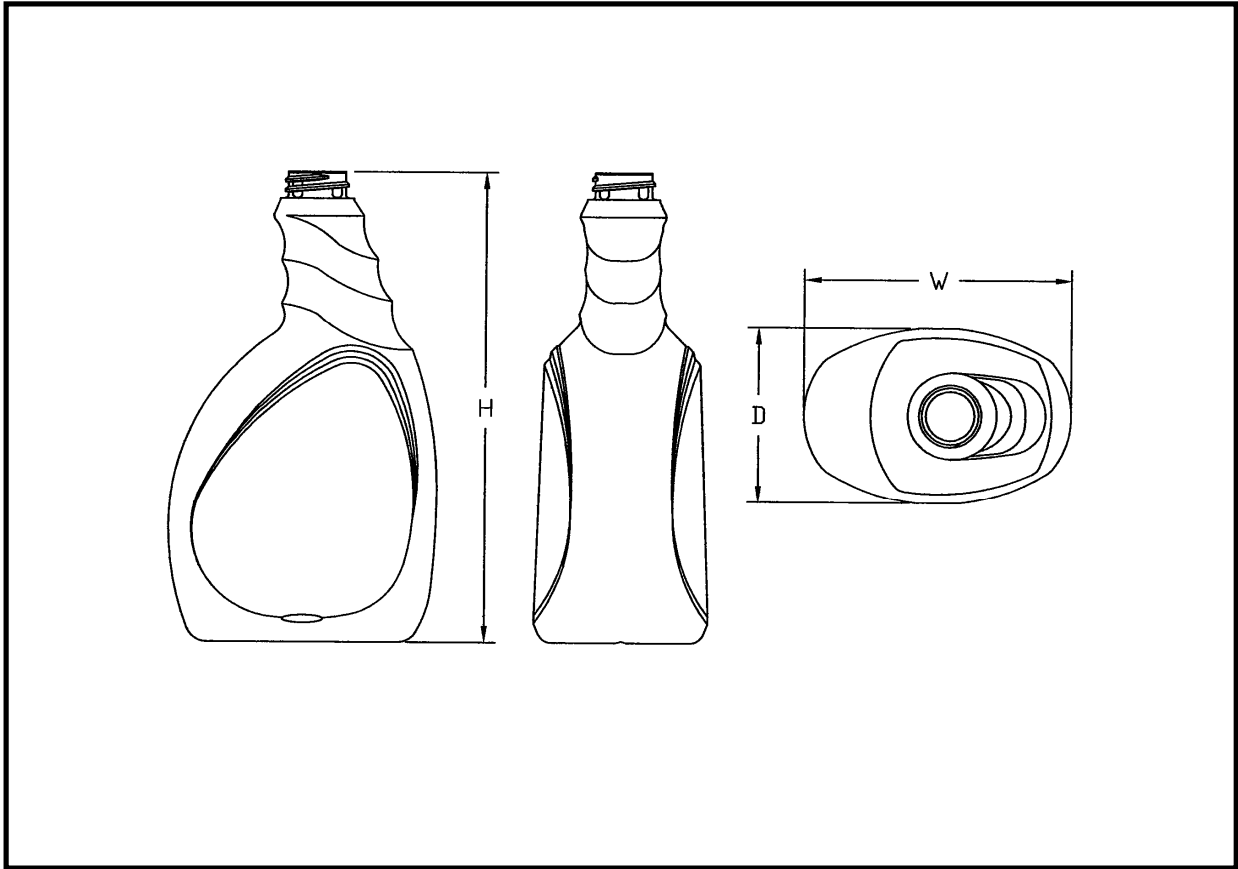

EURO TWIST GRIP^(R) SPRAYER OVALS

CAPACITY	NECKS	MATERIAL	HEIGHT	WIDTH	DEPTH
27 oz / 800 ml*	28-400 Ramp	HDPE	8.21"	4.61"	3.08"
32 oz / 1 Liter	28-400 Ramp	HDPE	8.602"	4.965"	3.253"
32 oz / 1 Liter	28mm 6Ratchet	HDPE	8.829"	4.965"	3.253"
32 oz / 1 Liter	28mm 8Ratchet	HDPE	8.829"	4.965"	3.253"
32 oz / 1 Liter	28mm HP2/HP3 Hose End**	HDPE	8.99"	4.965"	3.253"

Design Patent # US D548,093 S

*Available with or without view stripe.

**Only to be used with a WestRock/MWW/Calmar Hose End Ratcheted Closure.

Other sizes available upon request.

EURO TWIST GRIP^(R) SPRAYER OVAL

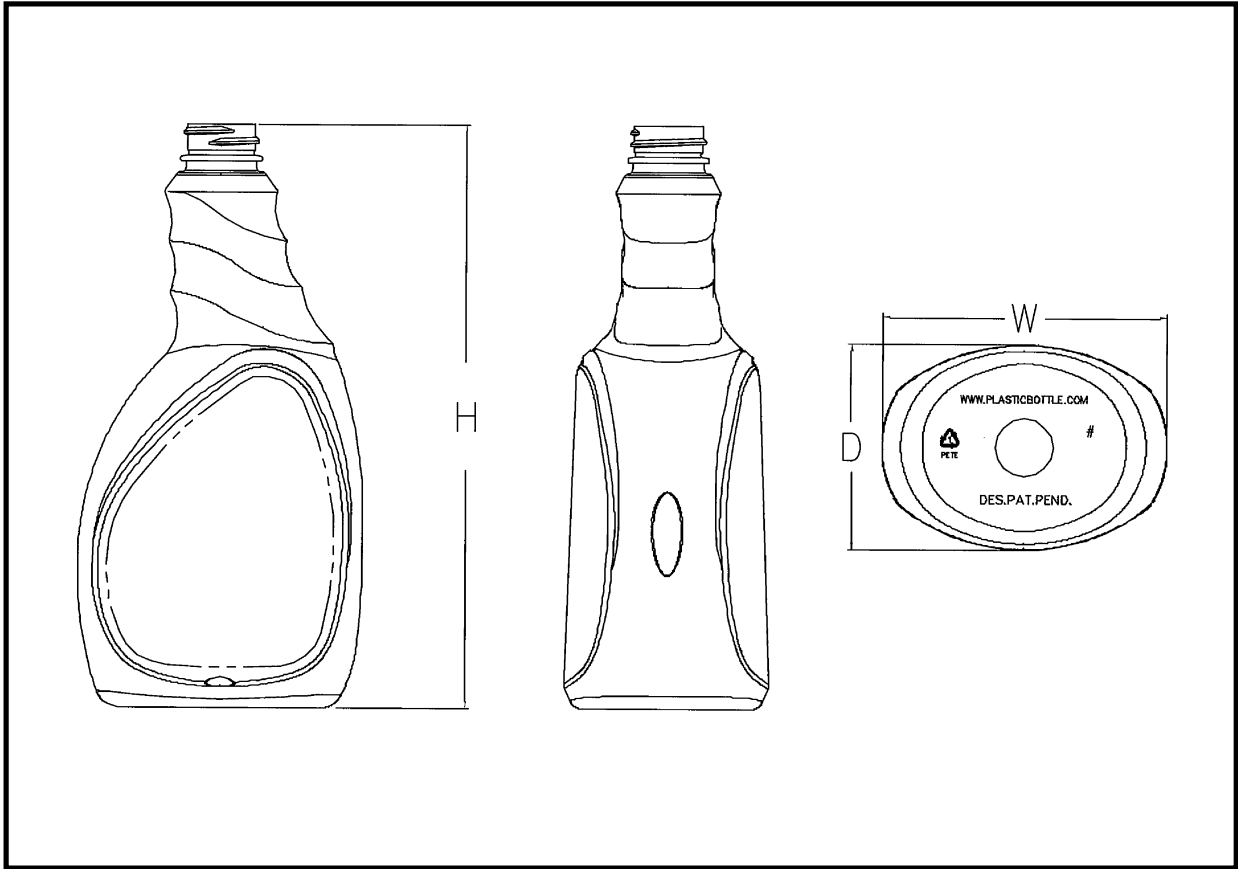

EURO TWIST GRIP^(R) SPRAYER OVAL

CAPACITY	NECKS	MATERIAL	HEIGHT	WIDTH	DEPTH
12 oz	28-410 Low H .615" H	OPET	6.62"	3.326"	2.434"
12 oz	28mm Ratchet	OPET	6.702"	3.326"	2.434"
16 oz	28mm Special .600" H	OPET	7.365"	3.668"	2.615"
16 oz	28mm Ratchet	OPET	7.447"	3.668"	2.615"
24 oz	28-400	OPET	8.347"	4.08"	2.94"
24 oz	28mm Ratchet	OPET	8.634"	4.08"	2.94"

Design Patent # US D548,093 S

GRIPPED SPRAYER OVAL

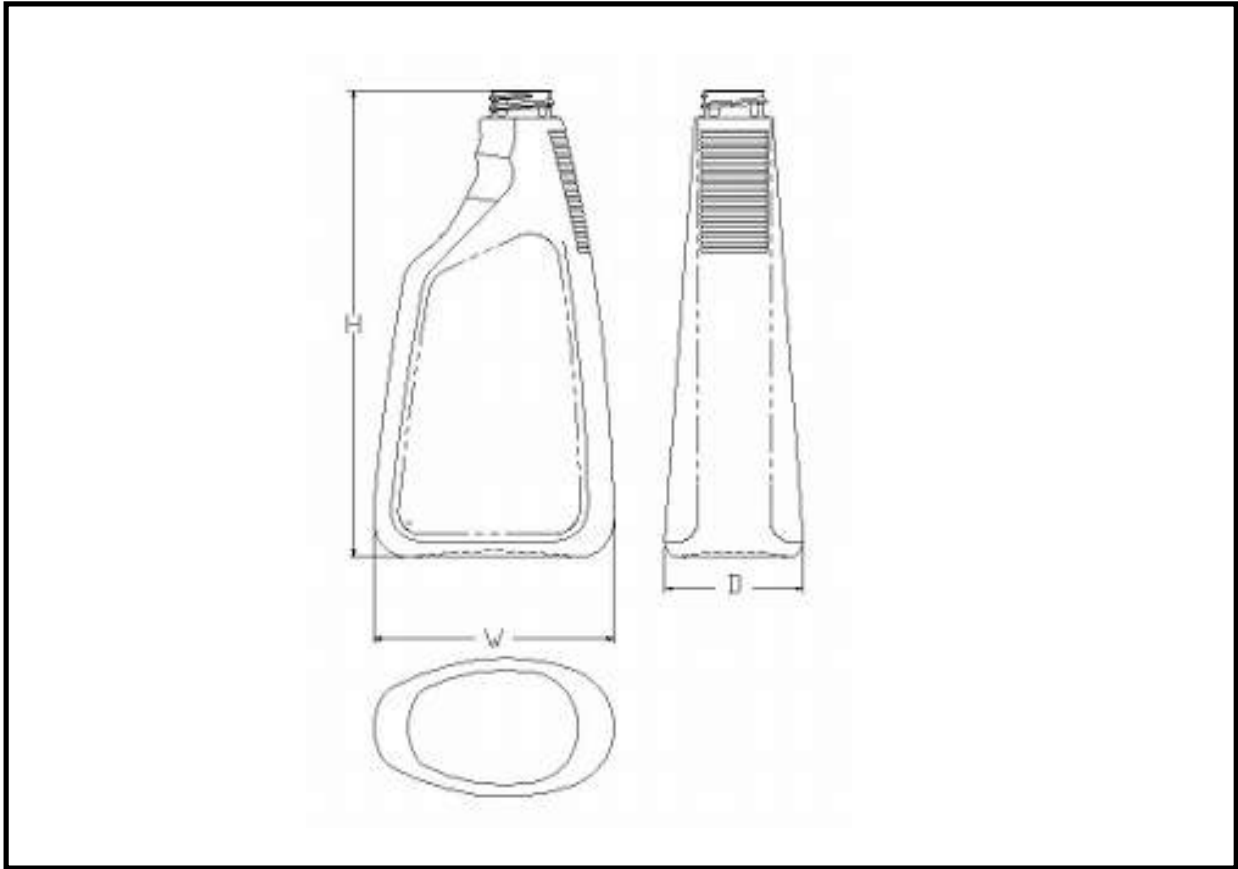

GRIPPED SPRAYER OVAL

CAPACITY	NECKS	MATERIAL	HEIGHT	WIDTH	DEPTH
16 oz / 500 ml	28-400 Ramp	HDPE	7.789"	3.997"	2.307"

PREMIER PISTOL GRIP SPRAYER OVALS

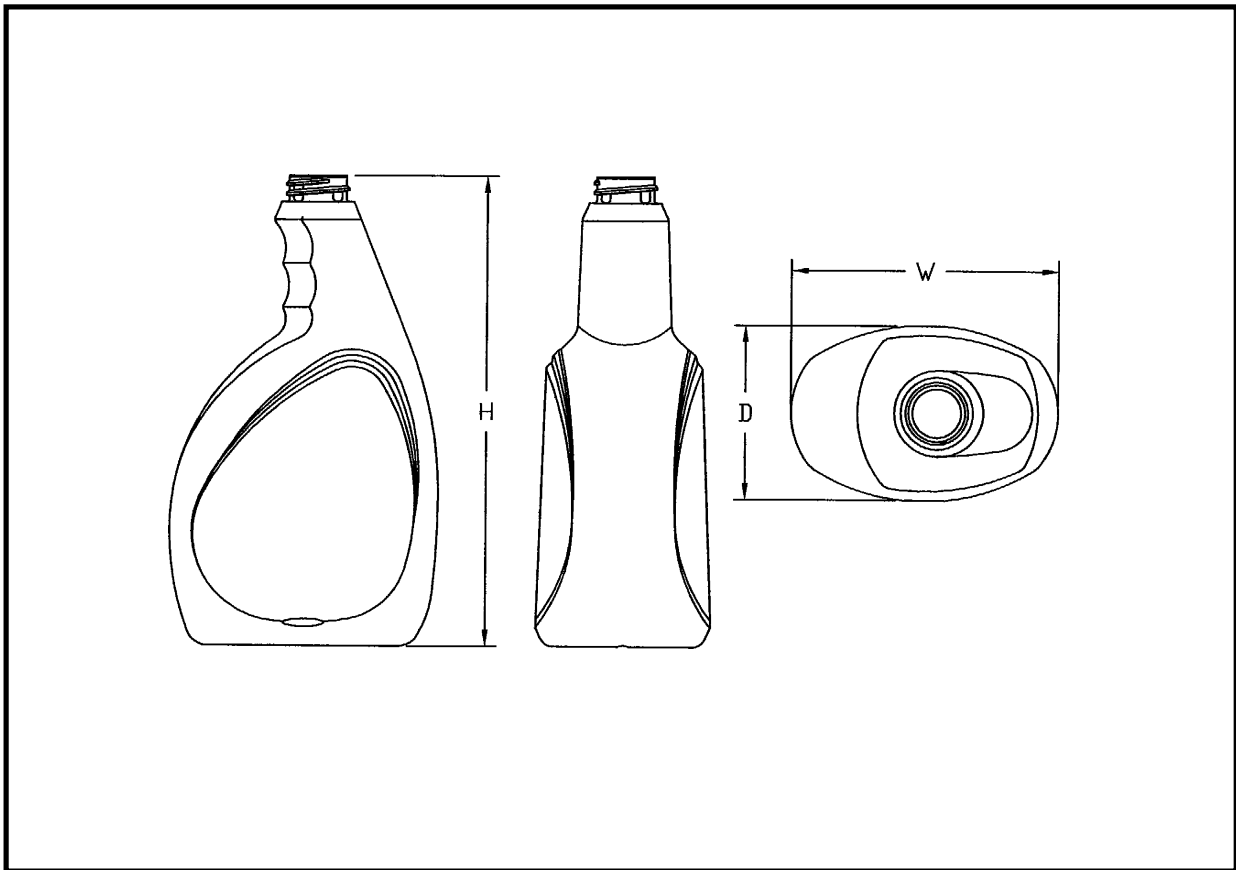

PREMIER PISTOL GRIP SPRAYER OVALS

CAPACITY	NECKS	MATERIAL	HEIGHT	WIDTH	DEPTH
32 oz / 1 Liter	28-400 Ramp	HDPE	8.602"	4.965"	3.253"
32 oz / 1 Liter	28mm 6Ratchet	HDPE	8.829"	4.965"	3.253"
32 oz / 1 Liter	28mm 8Ratchet	HDPE	8.829"	4.965"	3.253"
32 oz / 1 Liter	28mm HP2/HP3 Hose End*	HDPE	8.99"	4.965"	3.253"

Design Patent #429,159

*Only to be used with a WestRock/MWW/Calmar Hose End Ratcheted Closure

MILLENNIUM TWIST GRIP^(R) SPRAYER OVAL

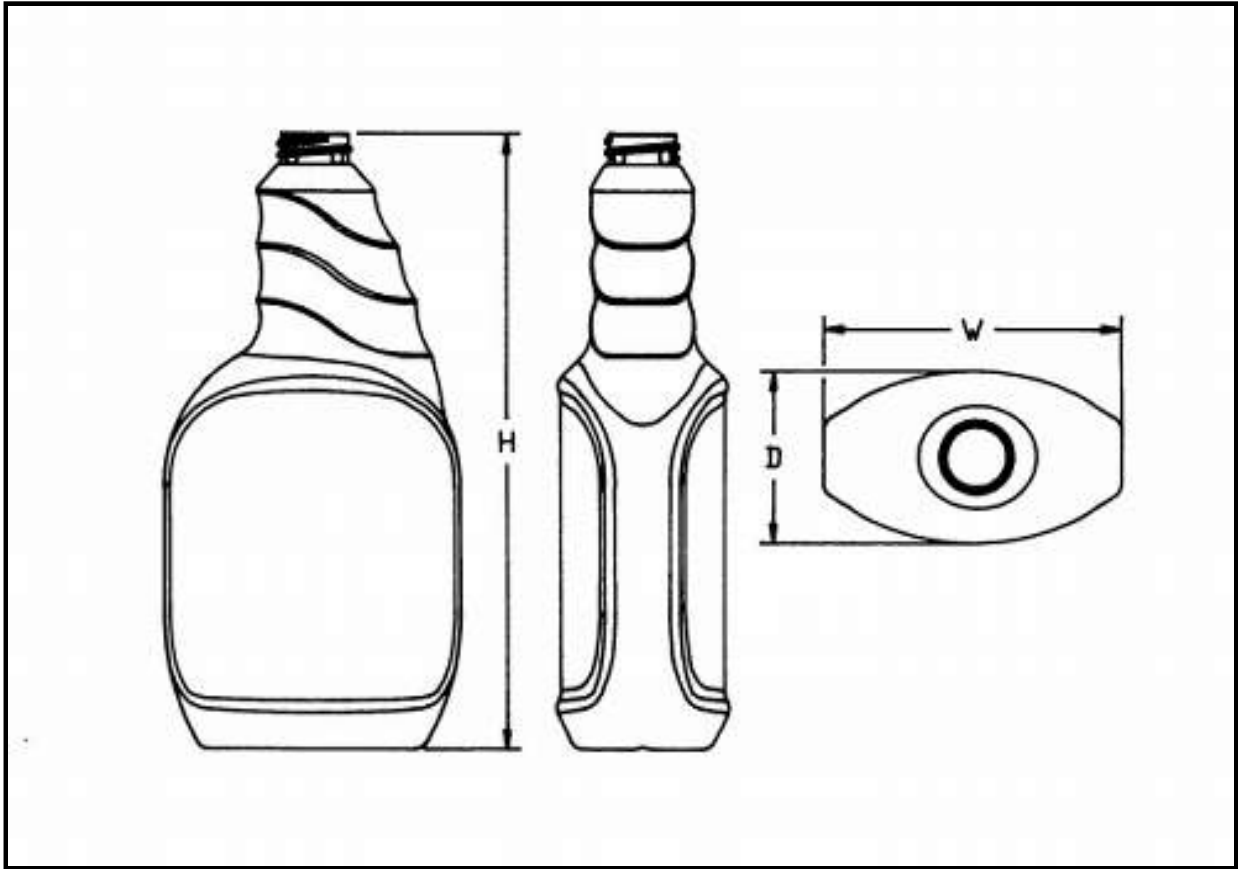

MILLENNIUM TWIST GRIP^(R) SPRAYER OVAL

CAPACITY	NECKS	MATERIAL	HEIGHT	WIDTH	DEPTH
26 oz	28-400 Ramp	PVC	9.03"	4.362"	2.48"

MILLENNIUM TWIST GRIP^(R) SPRAYER OVAL

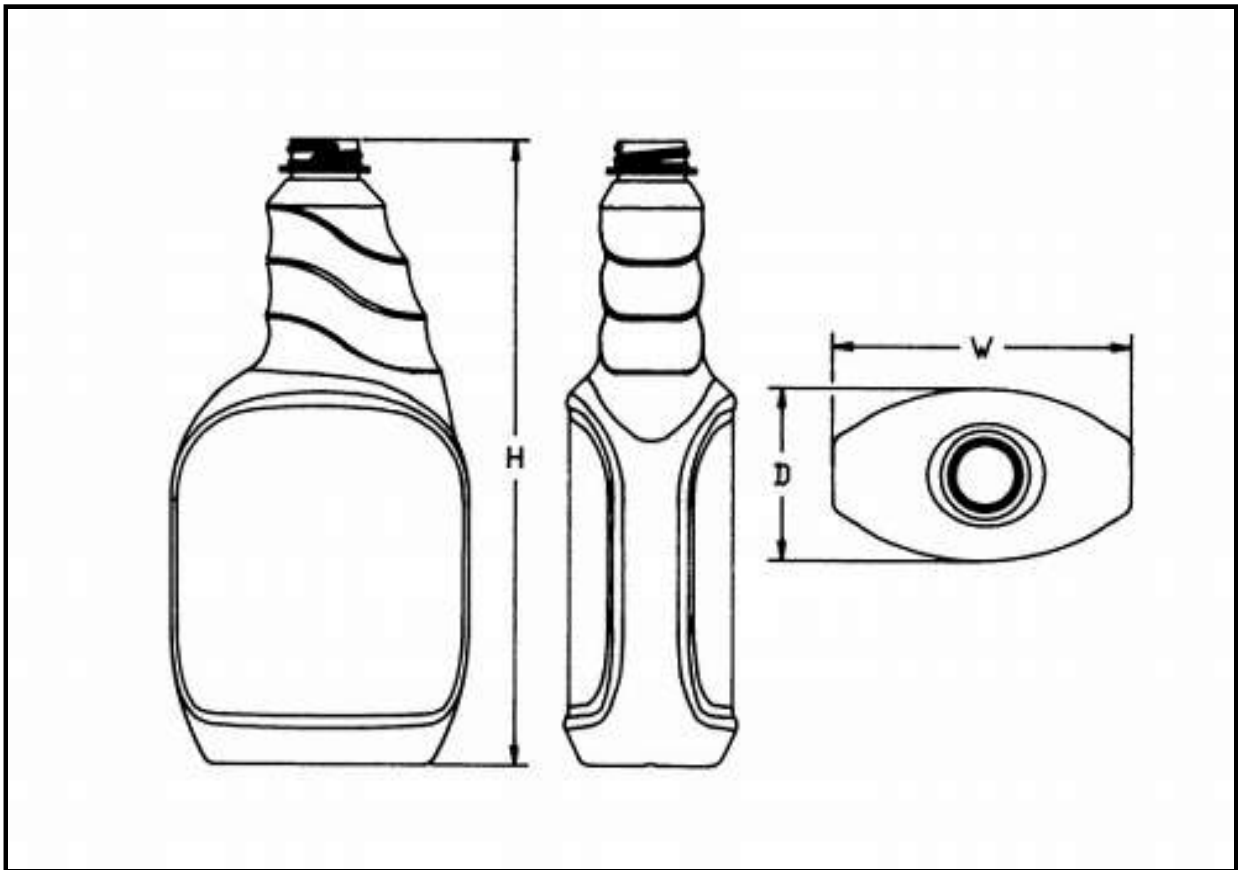

MILLENNIUM TWIST GRIP^(R) SPRAYER OVAL

CAPACITY	NECKS	MATERIAL	HEIGHT	WIDTH	DEPTH
16 oz / 500 ml	28-400 .460" H	OPET	7.953"	4.362"	2.026"
26 oz	28-400 .475"	OPET	9.228"	4.362"	2.53"
26 oz	28mm Ratchet	OPET	9.42"	4.362"	2.53"
32 oz	28-400	OPET	9.228"	4.362"	3.02"
32 oz	28mm Ratchet	OPET	9.49"	4.362"	3.02"

PBC TWIST GRIP^(R) SPRAYER OVALS

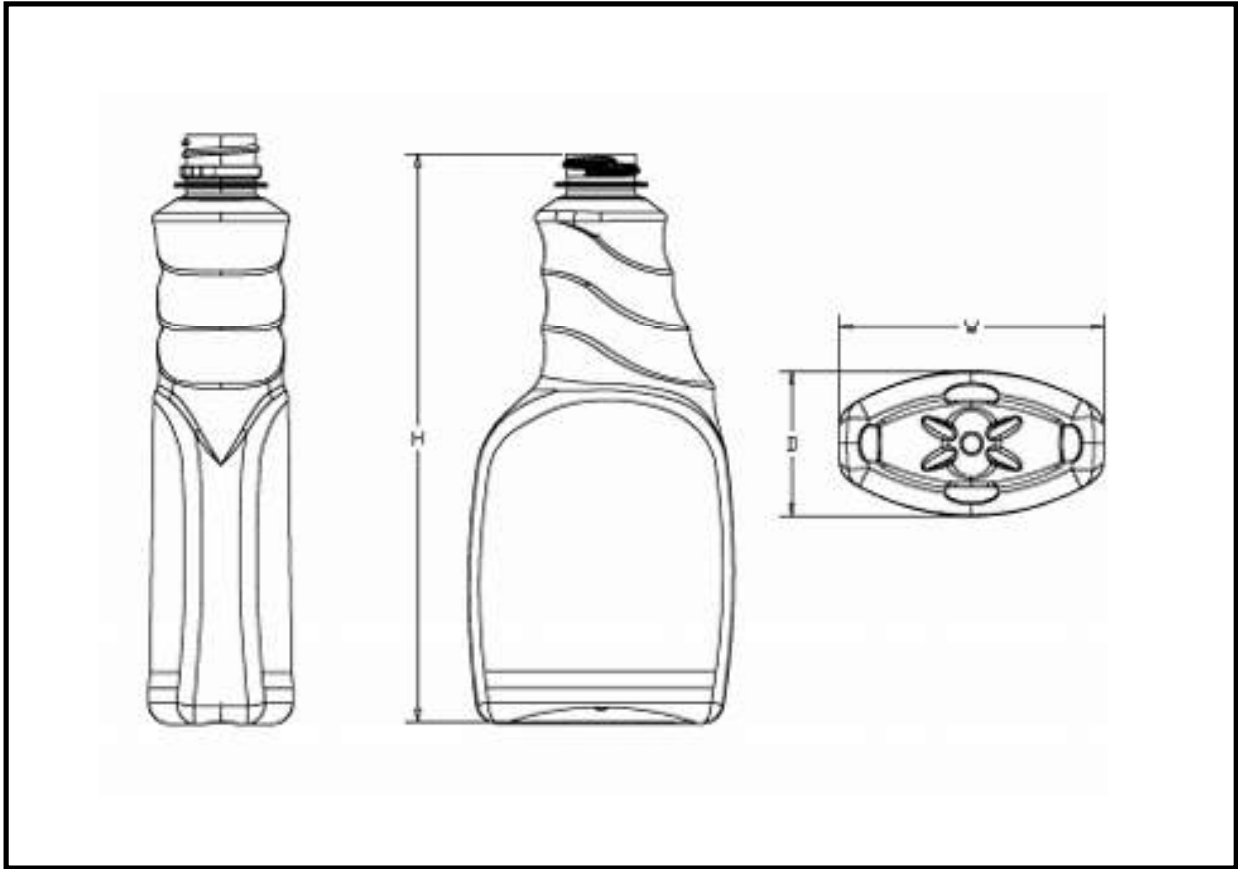

PBC TWIST GRIP^(R) SPRAYER OVALS

CAPACITY	NECKS	MATERIAL	HEIGHT	WIDTH	DEPTH
16 oz	28-400	OPET	8.057"	3.74"	2.04"
16 oz	28mm Ratchet	OPET	8.325"	3.74"	2.04"

VERNON SPRAYER OVALS

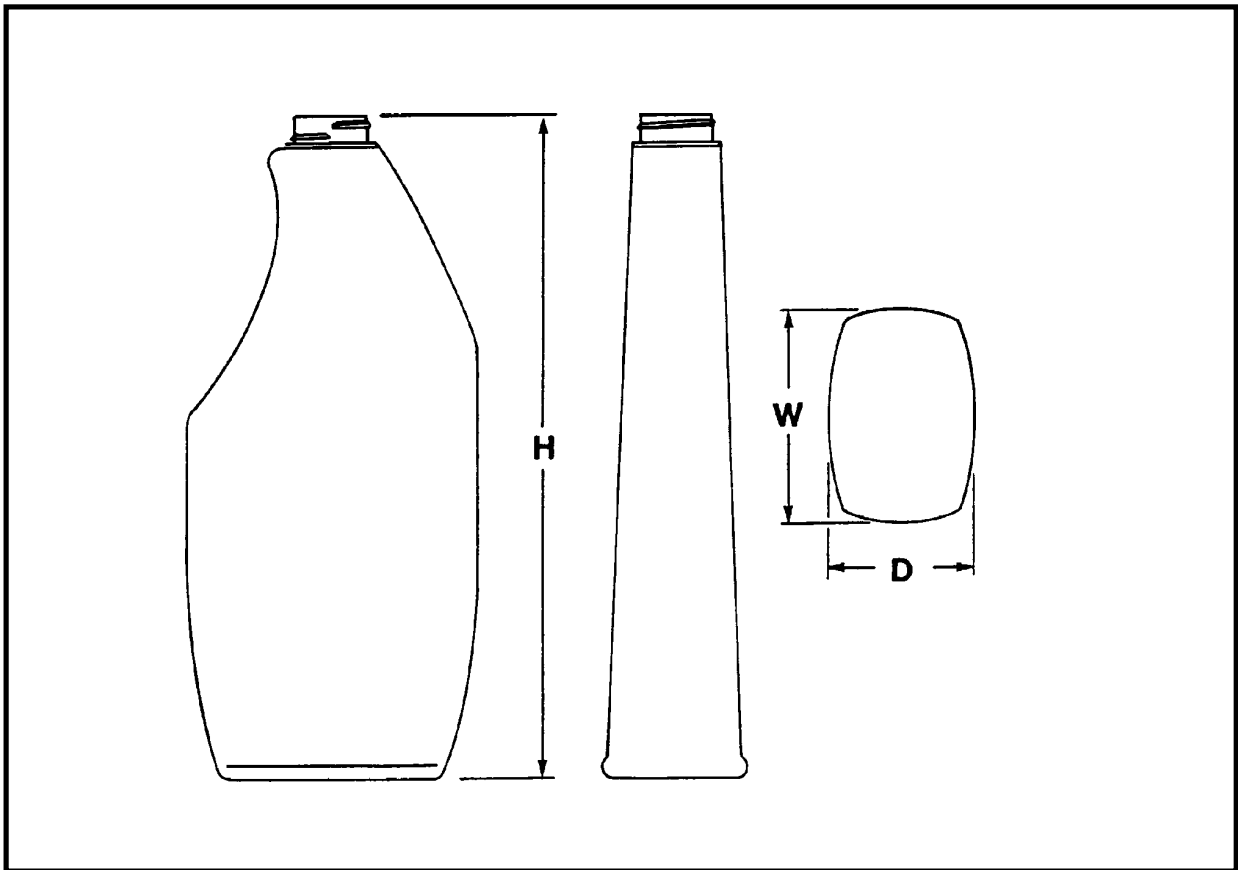

VERNON SPRAYER OVALS

CAPACITY	NECKS	MATERIAL	HEIGHT	WIDTH	DEPTH
22 oz	28-400	HDPE	9.33"	4.11"	2.10"
22 oz	28-400 .465"	HDPE	9.41"	4.11"	2.10"
22 oz	28mm Anti-Rotational	HDPE	9.37"	4.11"	2.10"
22 oz	28-400 Ratchet	HDPE	9.58"	4.11"	2.10"

Available with and without view striping.

VIPER SPRAYER OVALS

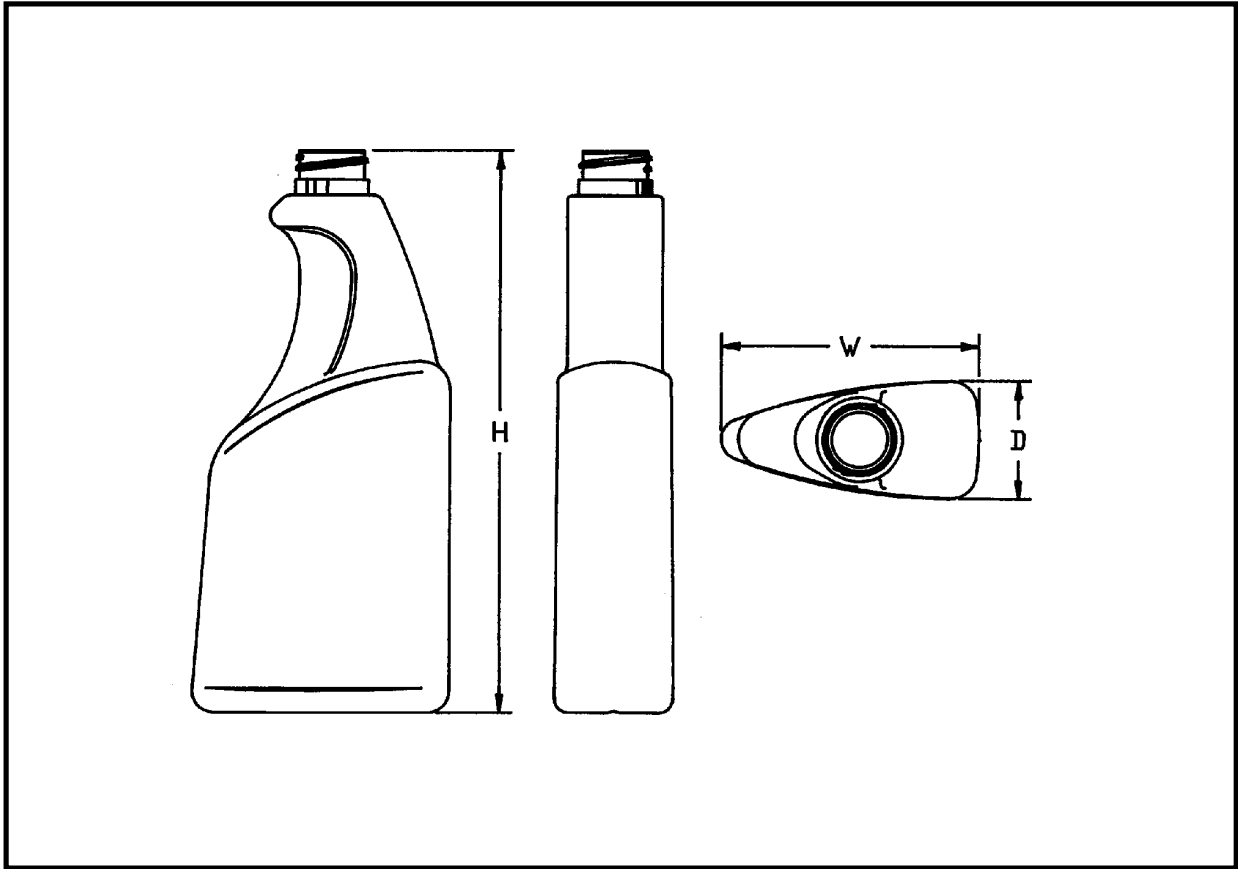

VIPER SPRAYER OVALS

CAPACITY	NECKS	MATERIAL	HEIGHT	WIDTH	DEPTH
16 oz	28-400 .450" H	PVC	8.407"	3.917"	1.903"
16 oz	28mm Anti-Backoff	PVC	8.67"	3.917"	1.903"

SPRAYER OVALS

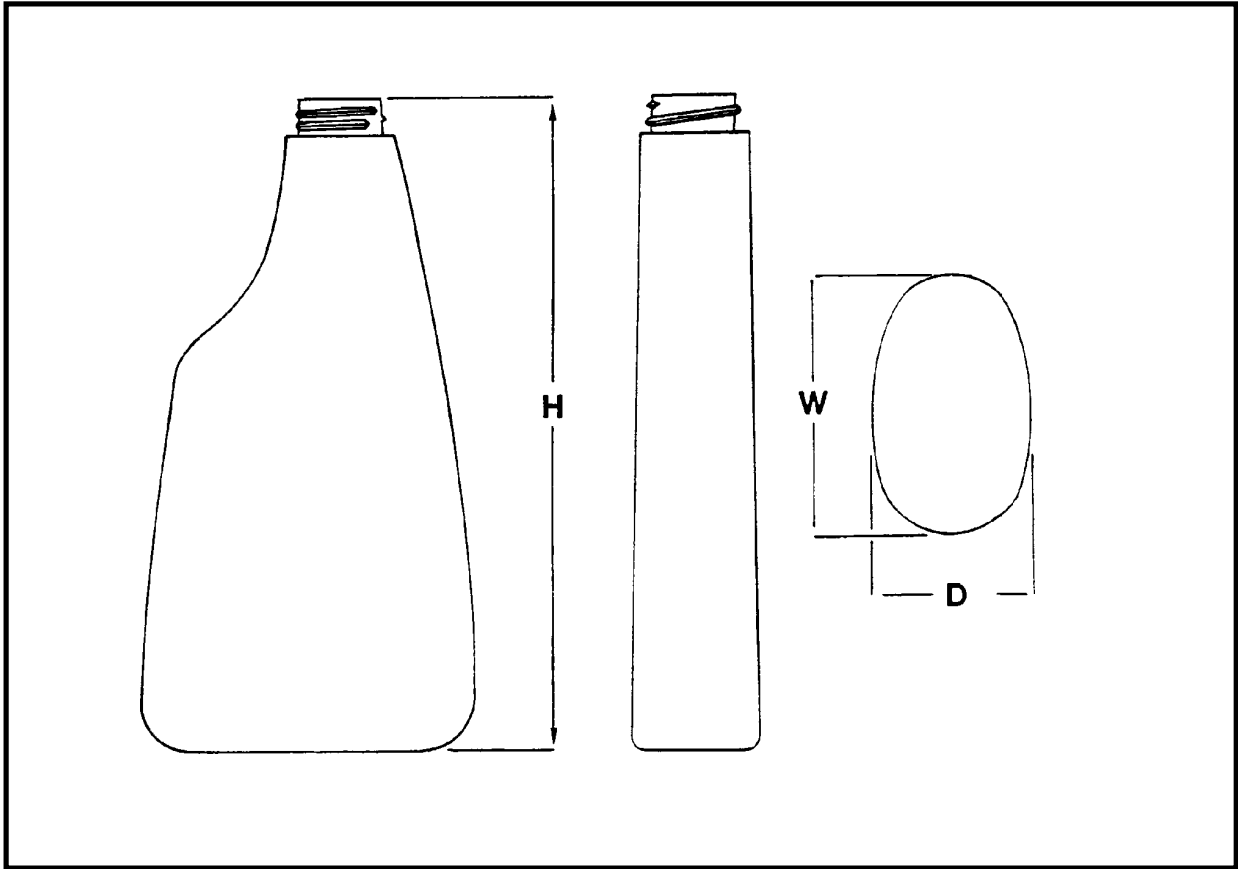

SPRAYER OVALS

CAPACITY	NECKS	MATERIAL	HEIGHT	WIDTH	DEPTH
16 oz	28-400 Ramp .420" H	PVC	7.695"	3.95"	2.27"
16 oz	28-400 Ramp .450" H	PVC	7.725"	3.95"	2.27"
16 oz	28-400 .616" H	PVC	7.891"	3.95"	2.27"
16 oz	28mm Anti Back Off	PVC	8.02"	3.95"	2.27"

SPRAYER OVALS

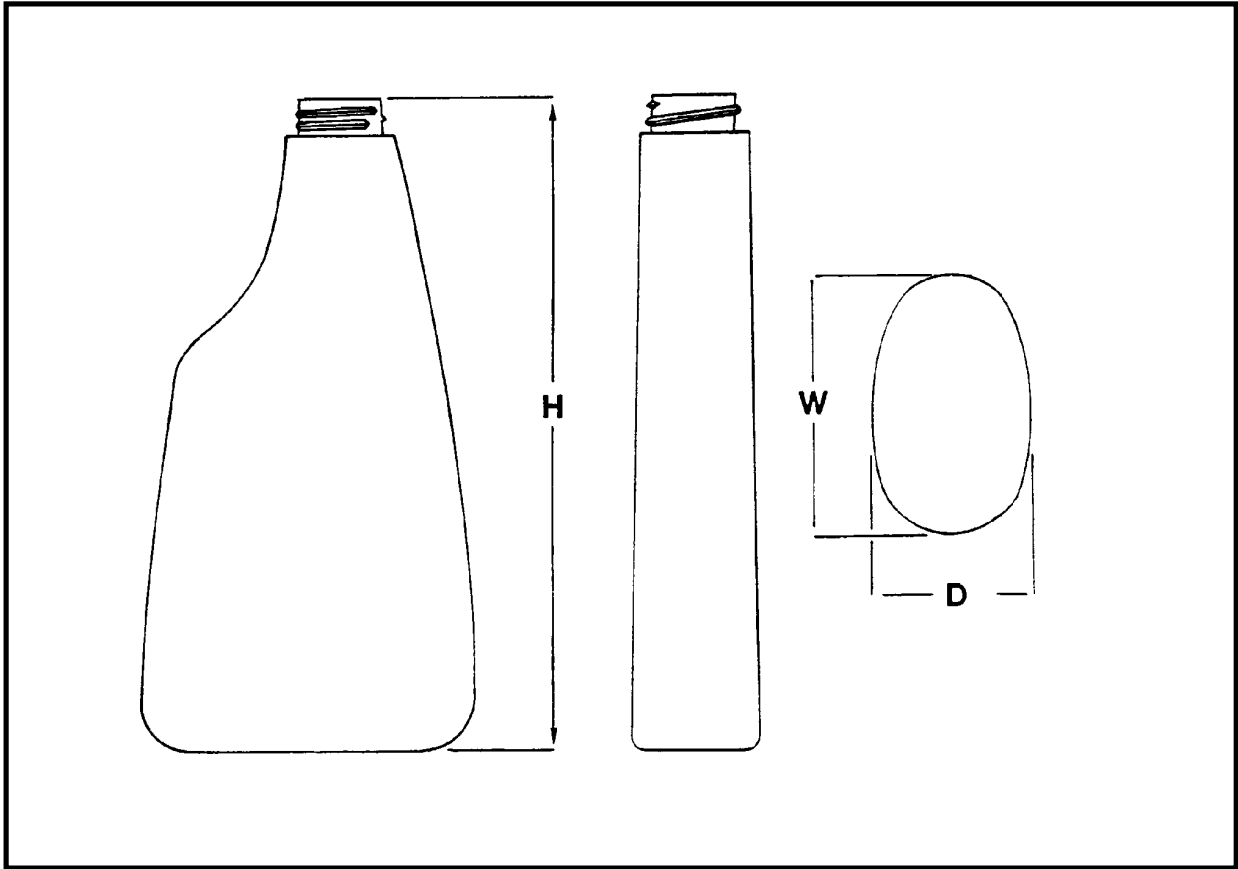

SPRAYER OVALS

CAPACITY	NECKS	MATERIAL	HEIGHT	WIDTH	DEPTH
17 oz / 500 ml*	28-400 Ramp .420" H	PVC	7.695"	4.02"	2.36"
17 oz / 500 ml*	28-400 Ramp .450" H	PVC	7.725"	4.02"	2.36"
17 oz / 500 ml*	28-400 .616" H	PVC	7.891"	4.02"	2.36"
17 oz / 500 ml*	28mm Anti Back Off	PVC	8.02"	4.02"	2.36"

*18 oz overflow

SPRAYER OVALS

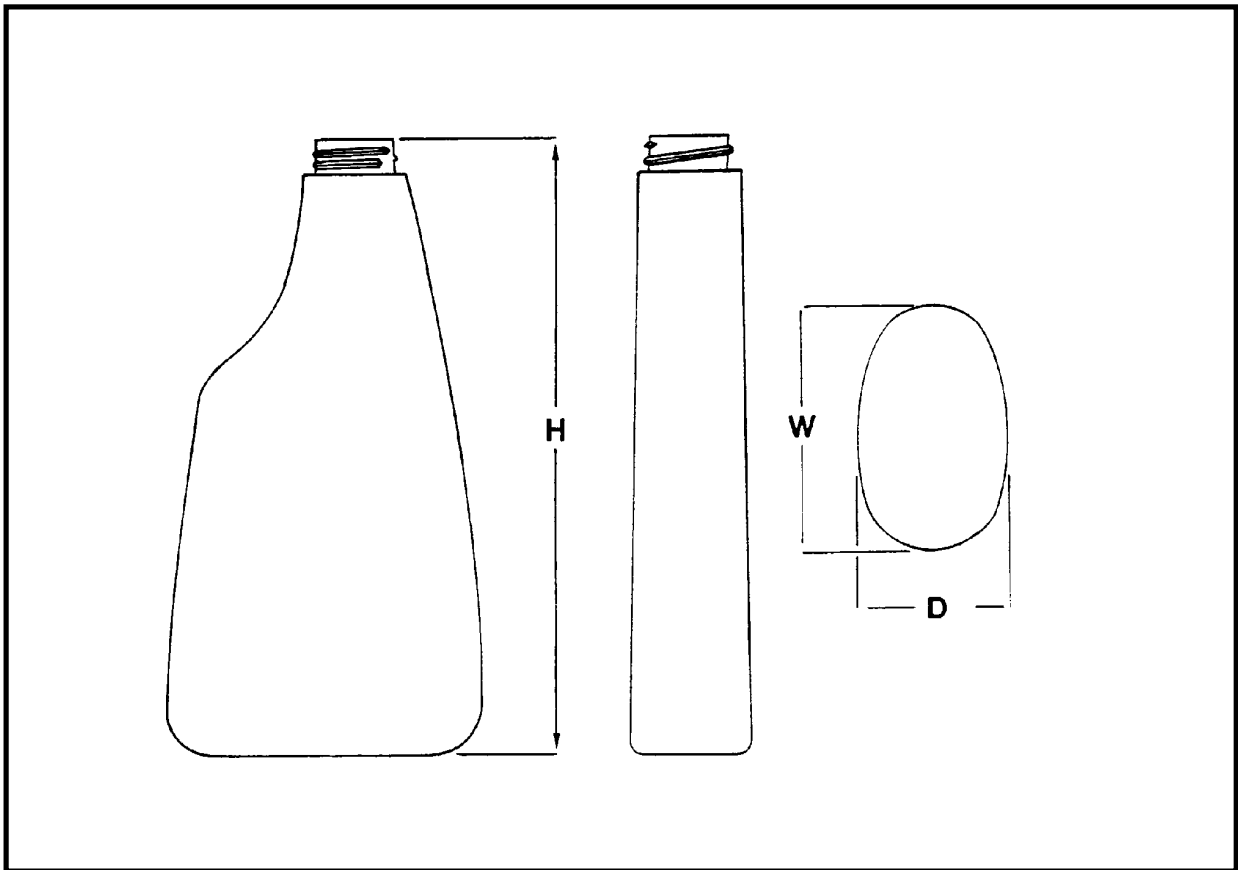

SPRAYER OVALS

CAPACITY	NECKS	MATERIAL	HEIGHT	WIDTH	DEPTH
16 oz/500 ml	28-400 Ramp .450"	HDPE	7.80"	4.11"	2.35"
16 oz/500 ml	28mm Anti-Rotational	HDPE	7.80"	4.11"	2.35"
16 oz/500 ml	28mm Ratchet	HDPE	7.98"	4.11"	2.35"
24 oz	28-400 Ramp .450"	HDPE	9.14"	4.19"	2.68"
24 oz	28mm Ratchet	HDPE	9.32"	4.19"	2.68"
24 oz	28mm 6Ratchet Mixor*	HDPE	9.363"	4.19"	2.68"

*Use with WestRock Ratchet Trigger Sprayer

SPRAYER OVALS

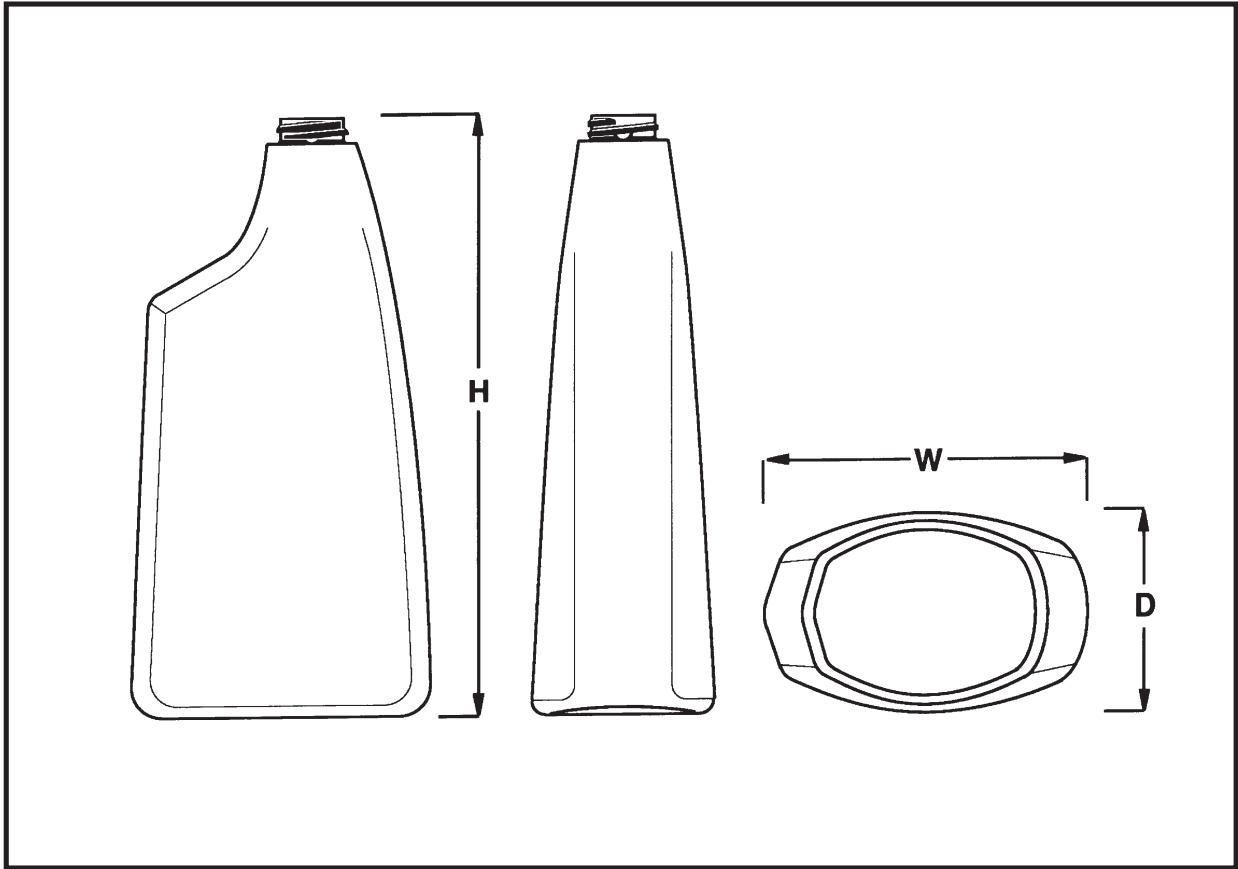

SPRAYER OVALS

CAPACITY	NECKS	MATERIAL	HEIGHT	WIDTH	DEPTH
32 oz	28-400 Ramp	HDPE	9.54"	4.78"	2.92"

PANTHER SPRAYER OVALS

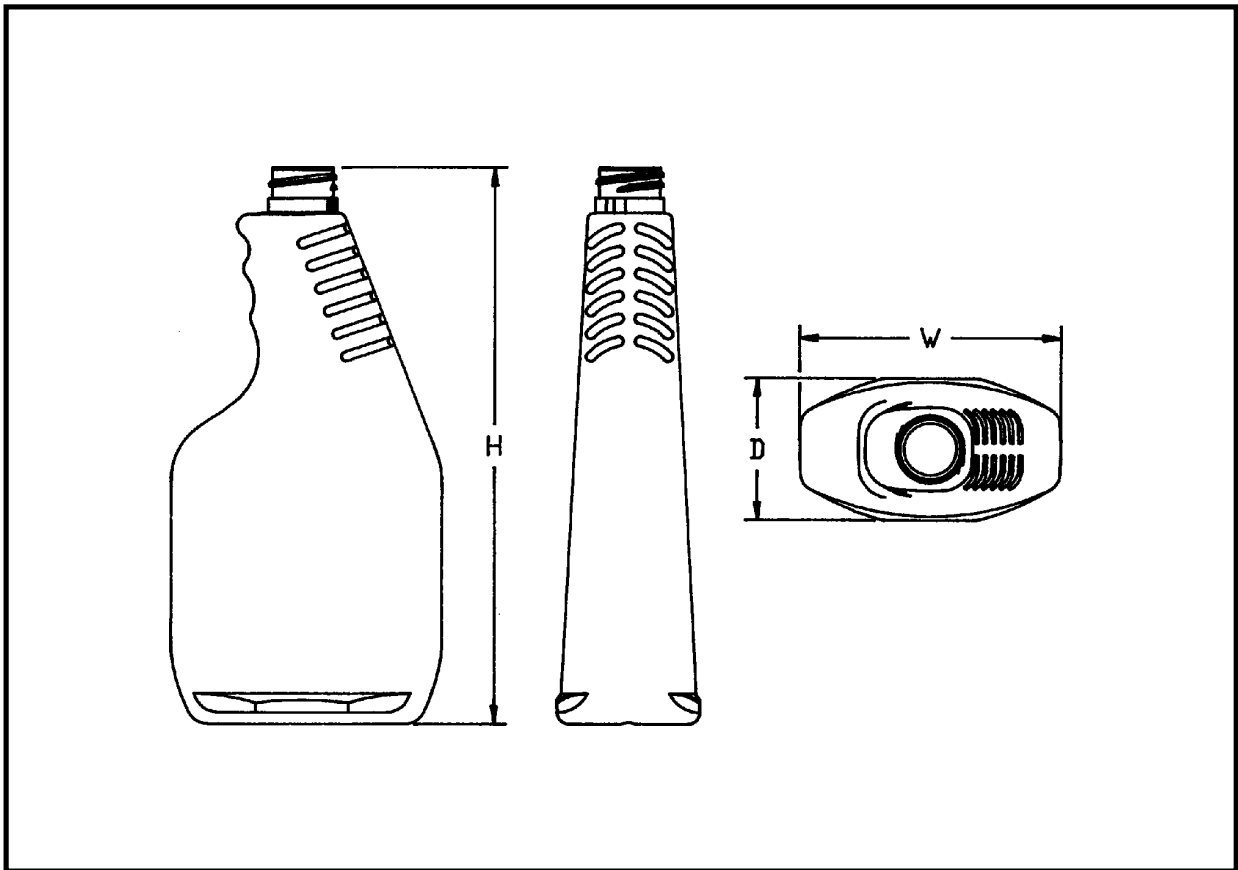

PANTHER SPRAYER OVALS

CAPACITY	NECKS	MATERIAL	HEIGHT	WIDTH	DEPTH
22 oz	28-400 .440" H	HDPE	9.00"	4.37"	2.315"
22 oz	28mm Anti-Backoff	HDPE	9.085"	4.37"	2.315"

RONDOUT OVALS

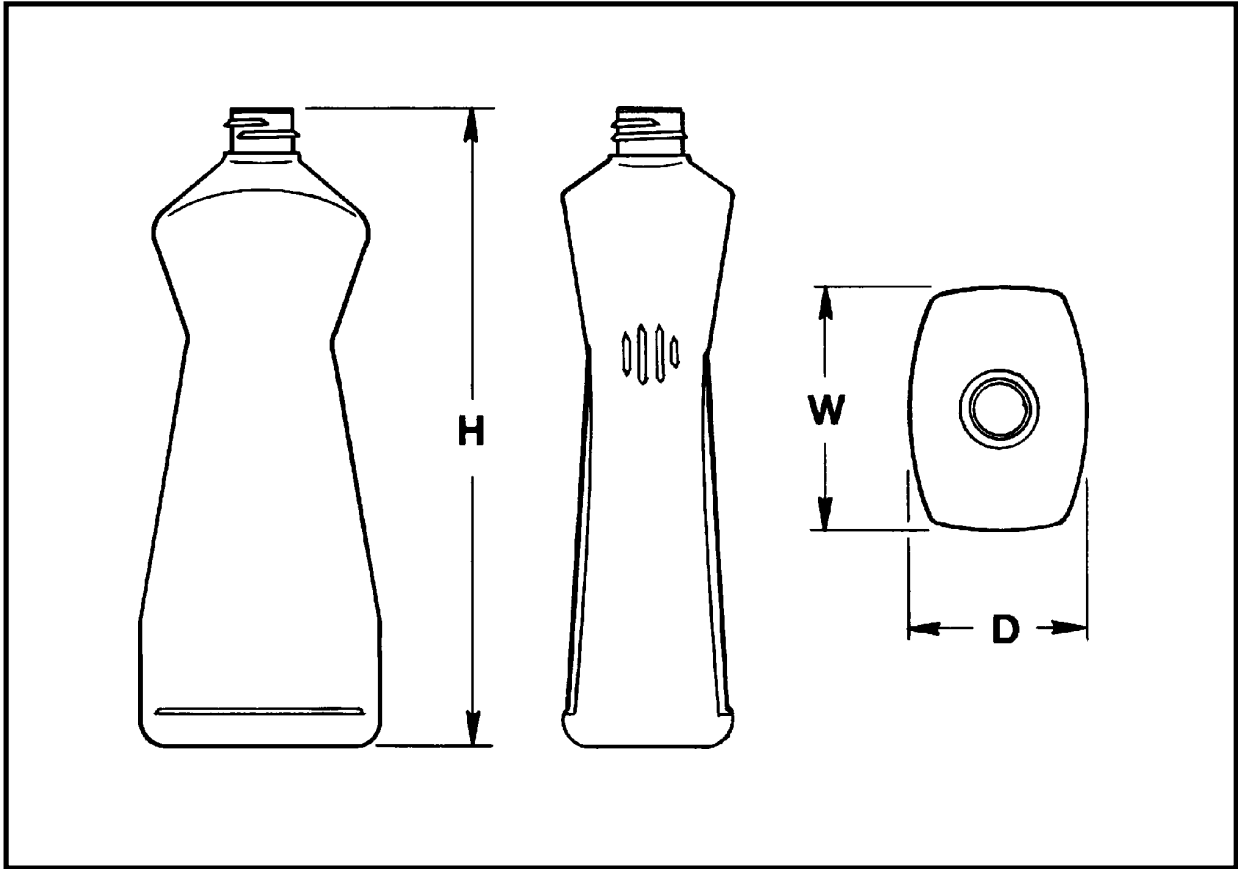

RONDOUT OVALS

CAPACITY	NECKS	MATERIAL	HEIGHT	WIDTH	DEPTH
22 oz	28-400	HDPE	9.03"	3.61"	2.45"
22 oz	28-410	HDPE	9.34"	3.61"	2.45"

RONDOUT OVALS

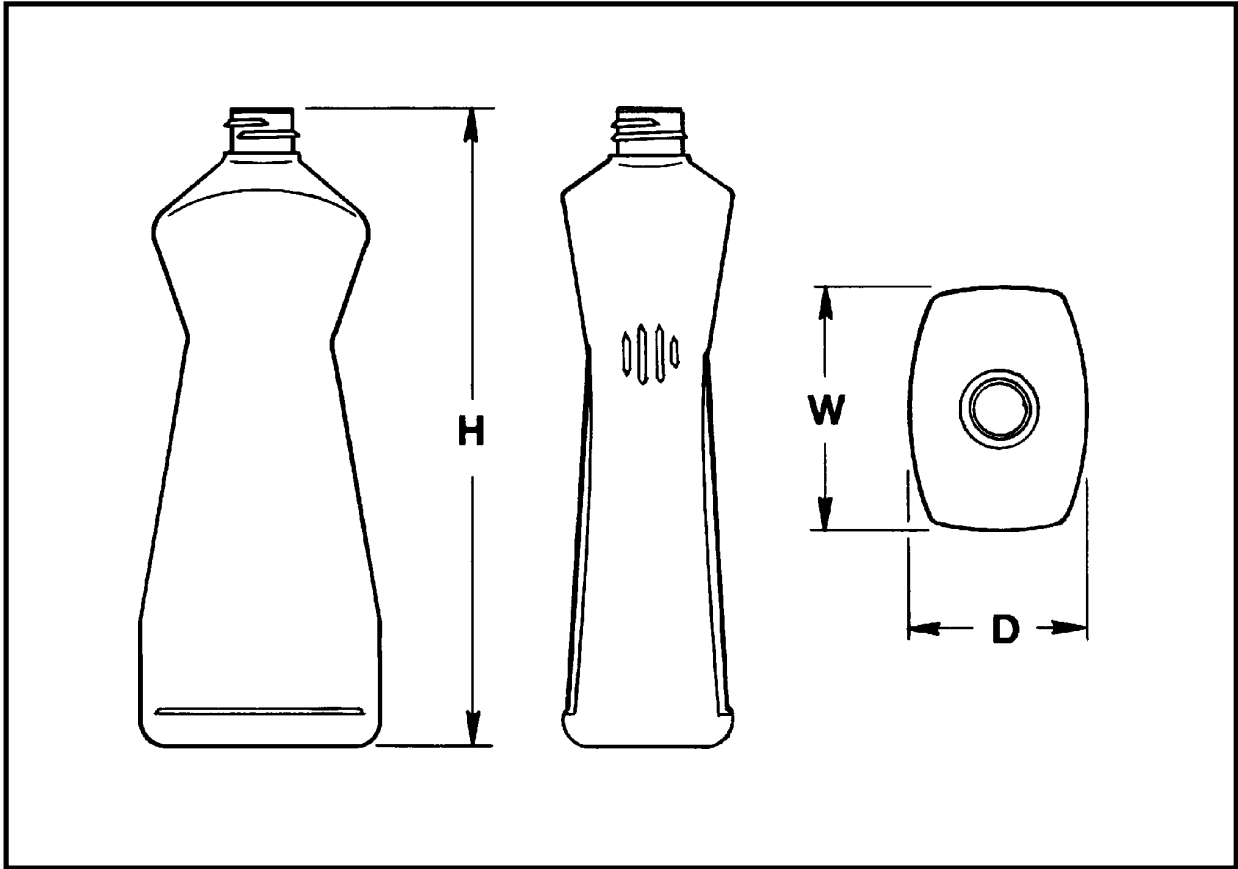

RONDOUT OVALS

CAPACITY	NECKS	MATERIAL	HEIGHT	WIDTH	DEPTH
32 oz	28-400	HDPE	10.50"	4.04"	2.88"
32 oz	28-415	HDPE	11.15"	4.04"	2.88"
32 oz	28P100	HDPE	10.63"	4.04"	2.88"

Available with or without view stripe.

ULTRA OVAL

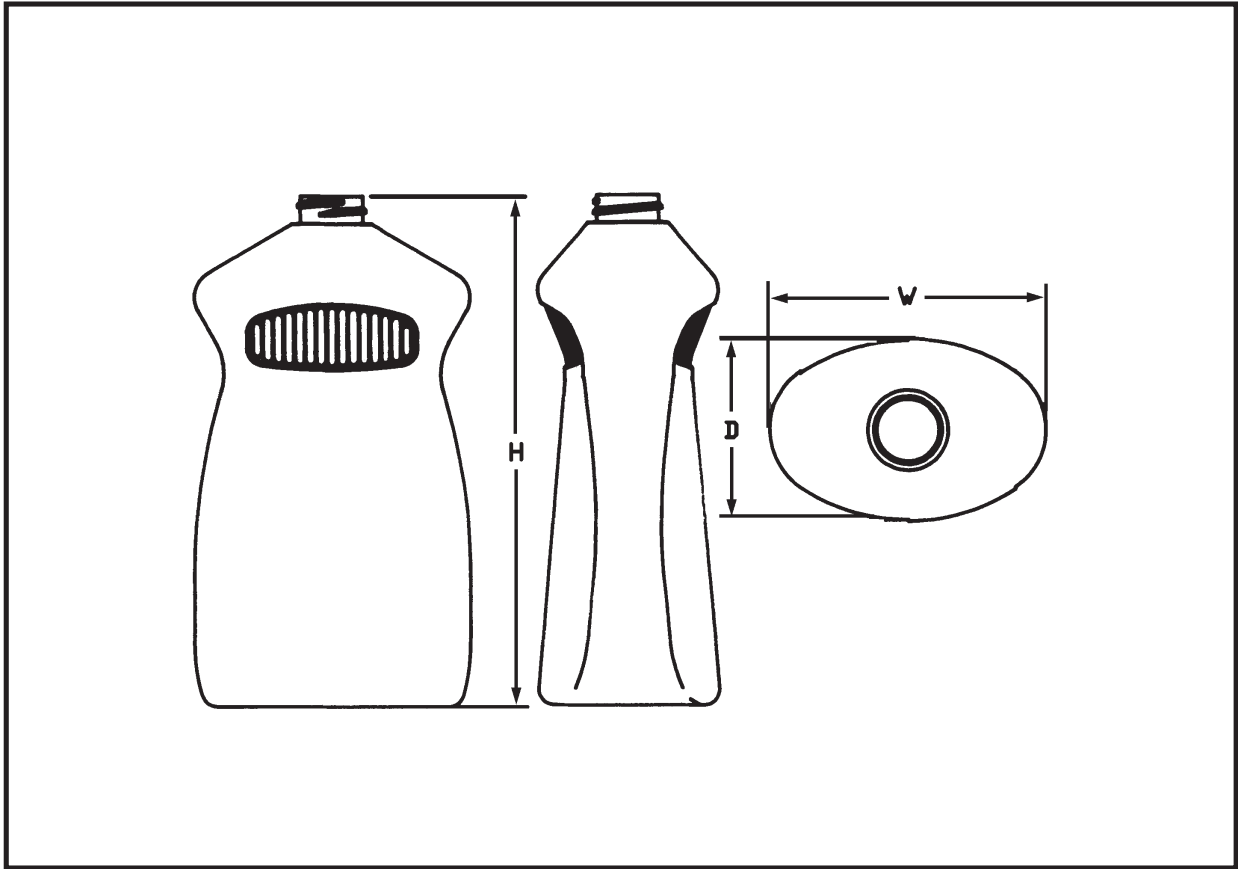

ULTRA OVAL

CAPACITY	NECKS	MATERIAL	HEIGHT	WIDTH	DEPTH
28 oz	28-400	HDPE	8.07"	4.35"	2.85"
28 oz	28P100	HDPE	8.16"	4.35"	2.85"

RONDOUT HANDLEWARE OVALS

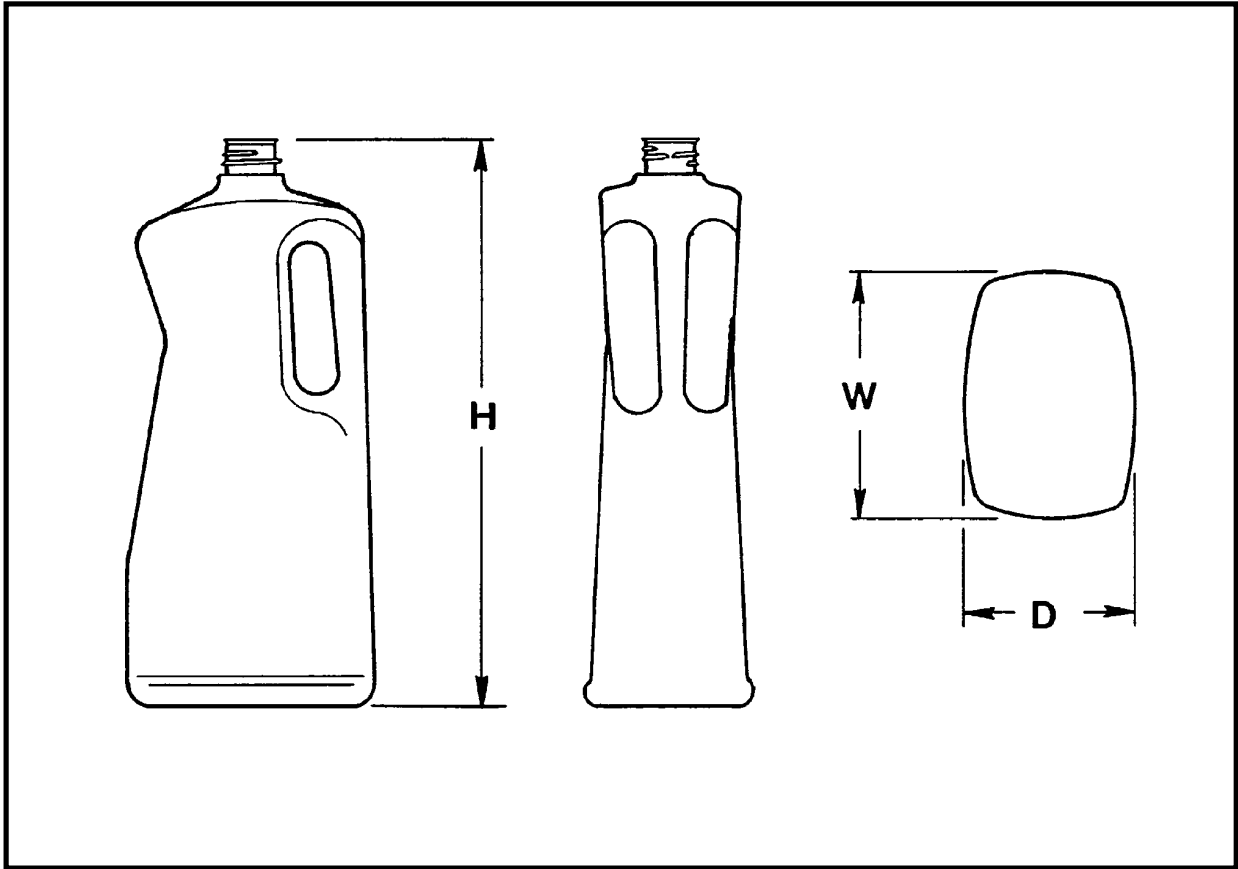

RONDOUT HANDLEWARE OVALS

CAPACITY	NECKS	MATERIAL	HEIGHT	WIDTH	DEPTH
42 oz	28P100	PVC or HDPE	10.62"	4.59"	3.35"
42 oz	28-400	HDPE	10.51"	4.59"	3.35"

Design Patent # 341,086

NEW FLAT OVAL

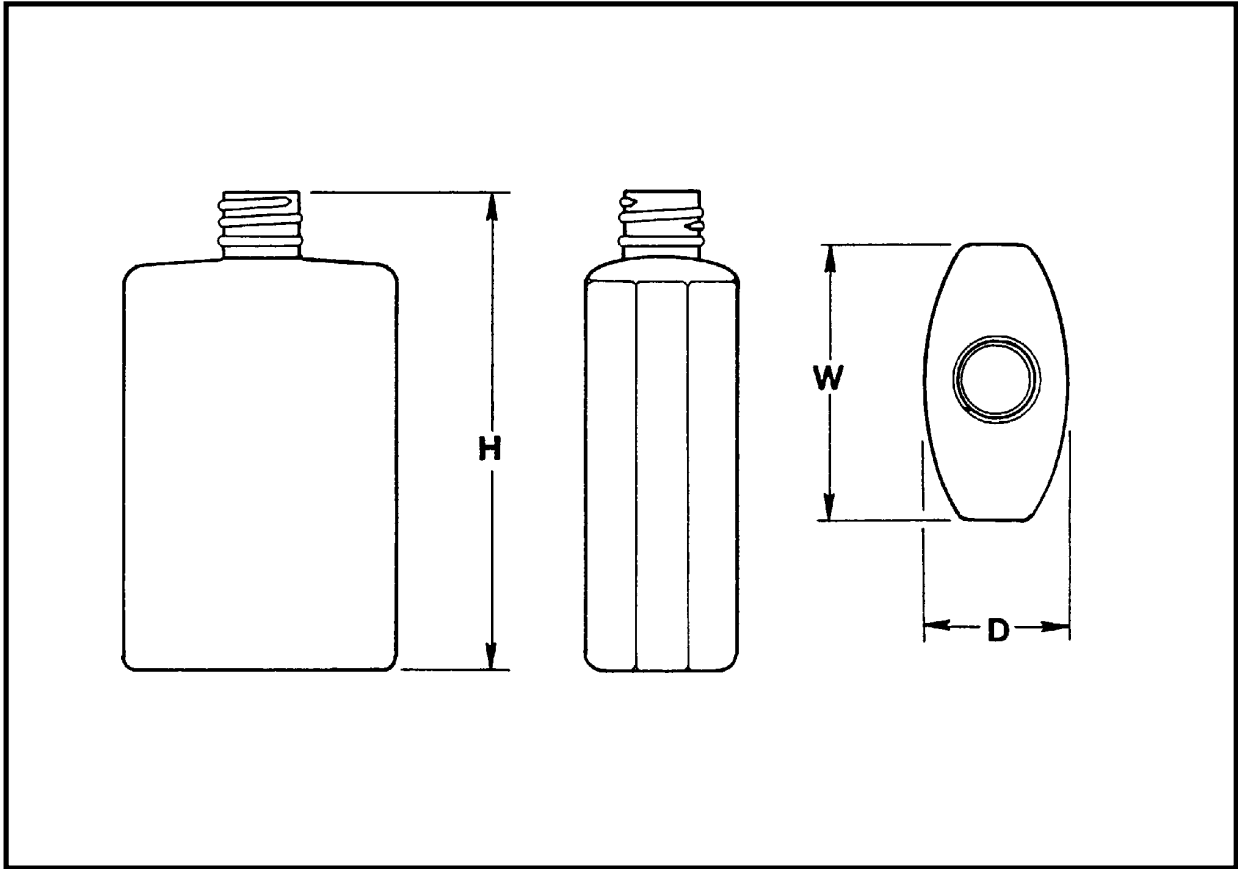

NEW FLAT OVAL

CAPACITY	NECKS	MATERIAL	HEIGHT	WIDTH	DEPTH
4 oz	20-410	HDPE	4.22"	2.43"	1.33"

WIDE HIGH BROW OVAL

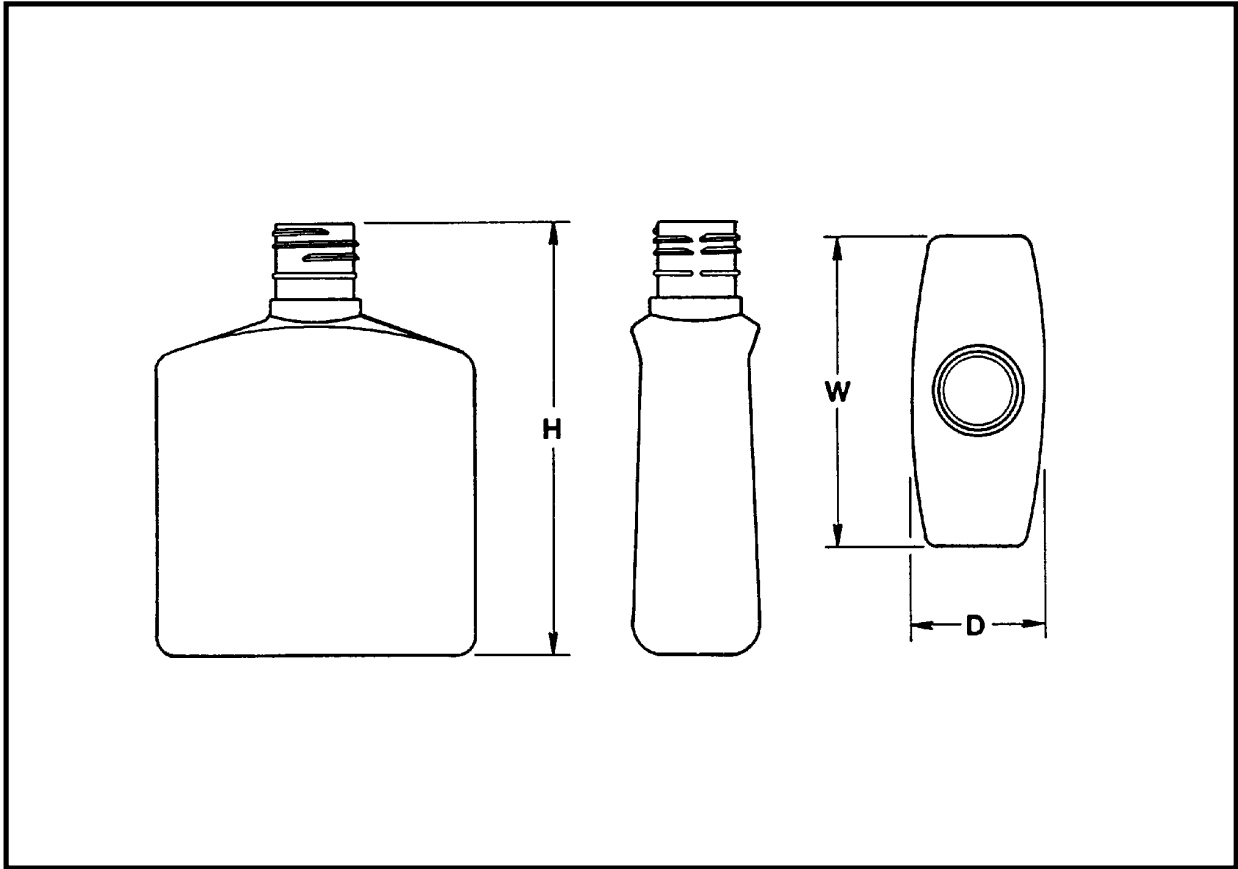

WIDE HIGH BROW OVAL

CAPACITY	NECKS	MATERIAL	HEIGHT	WIDTH	DEPTH
12 oz	24-415	HDPE	5.35"	4.03"	1.84"

WIDE HIGH BROW OVALS

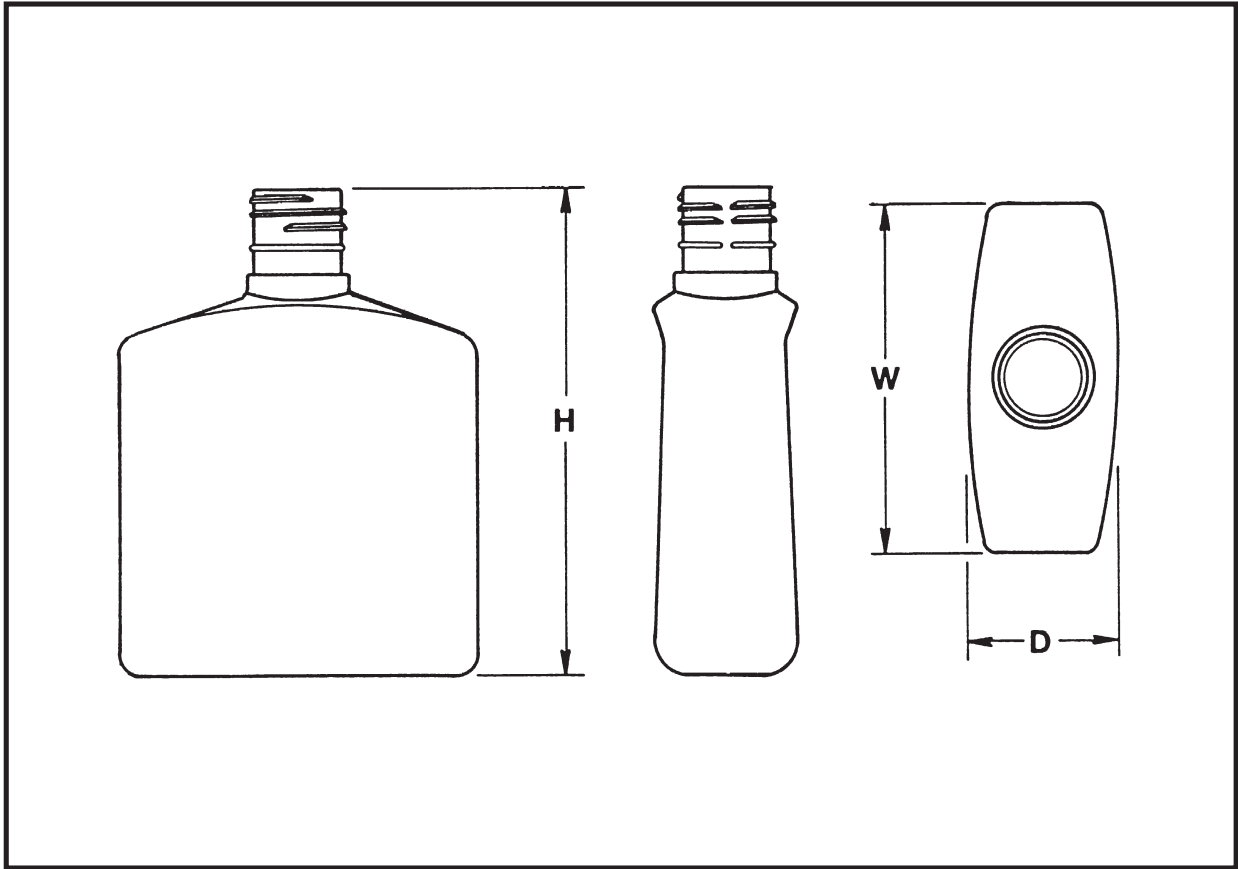

WIDE HIGH BROW OVALS

CAPACITY	NECKS	MATERIAL	HEIGHT	WIDTH	DEPTH
16 /17.46 oz	28-400	PVC	5.62"	4.58"	1.85"
16 /17.46 oz	28-410	PVC	5.93"	4.56"	1.85"
16 /17.46 oz	28-415	PVC	6.26"	4.56"	1.85"

Secondary capacity measurement represents cosmetic fill point to base of neck.
 Capacity of containers on this page also equivalent to 500 ml liquid.

WIDE HIGH BROW OVAL

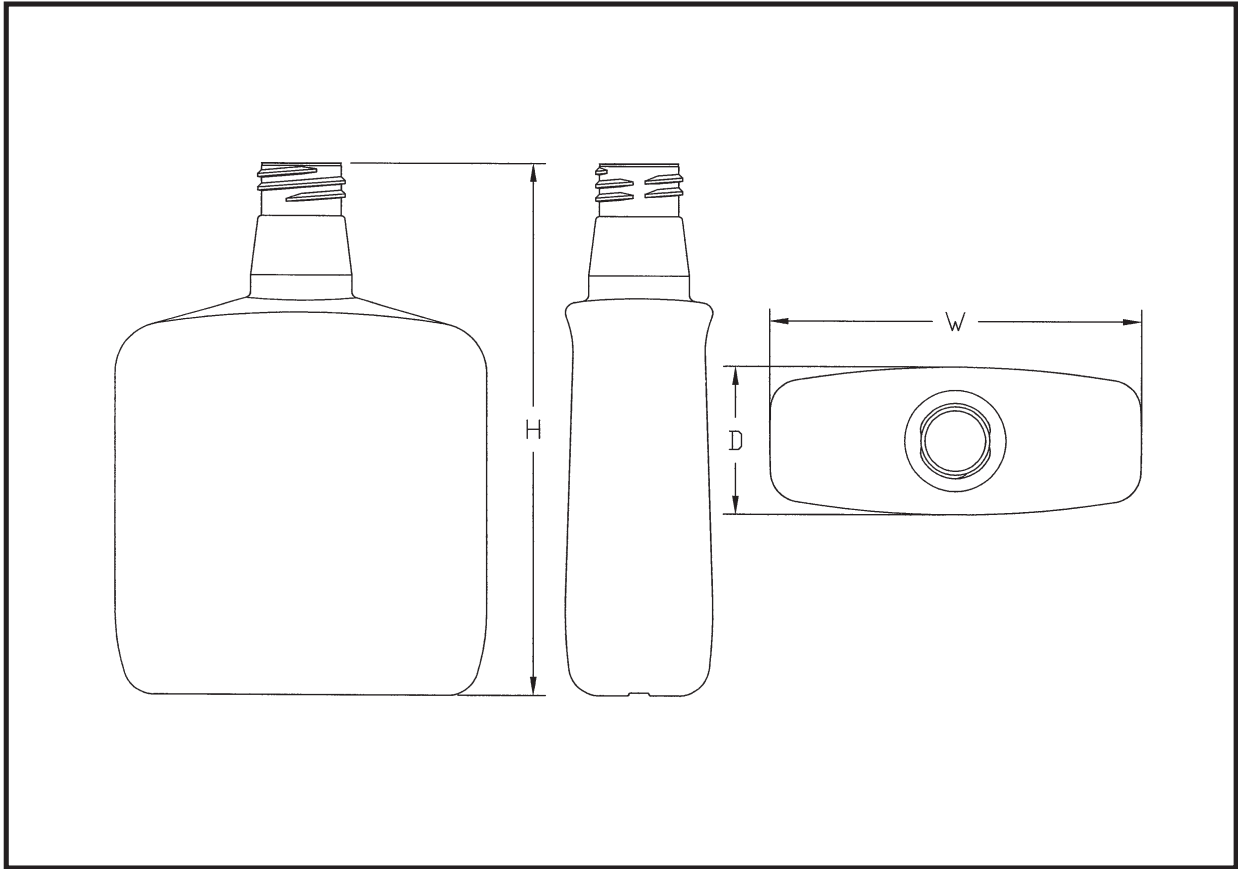

WIDE HIGH BROW OVAL

CAPACITY	NECKS	MATERIAL	HEIGHT	WIDTH	DEPTH
16 /17.46 oz	28mm Jigger	PVC	6.60"	4.595"	1.83'

28mm Jigger closure available through Plastic Bottle Corporation.
 Secondary capacity measurement represents cosmetic fill point to base of neck.
 Capacity of containers on this page also equivalent to 500 ml liquid.

TALL HIGH BROW OVALS

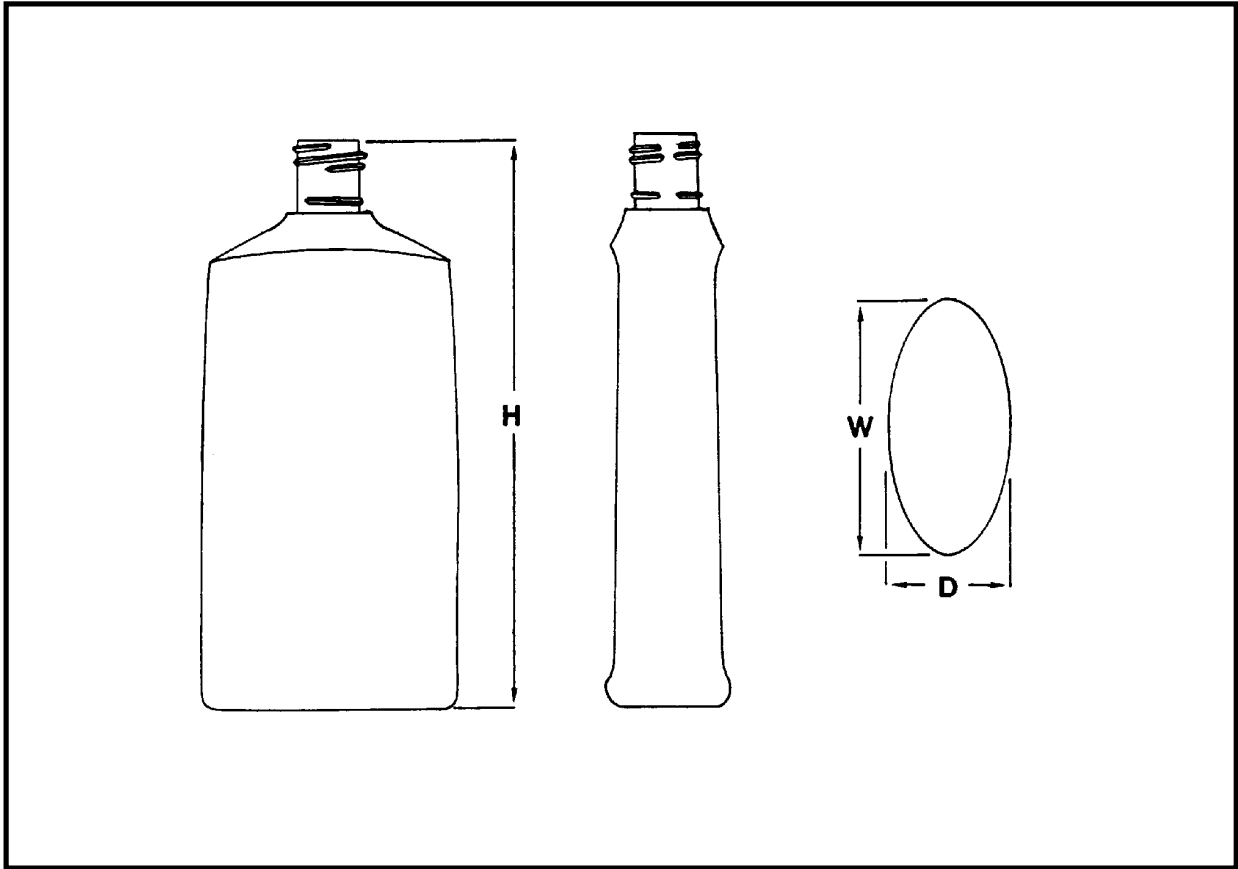

TALL HIGH BROW OVALS

CAPACITY	NECKS	MATERIAL	HEIGHT	WIDTH	DEPTH
16 /18.04 oz	28-400	PVC	7.96"	3.85"	1.85"
16 /18.04 oz	28-410	PVC	8.24"	3.85"	1.85"
16 /18.04 oz	28-415	PVC	8.63"	3.85"	1.85"

Secondary capacity measurement represents cosmetic fill point to base of neck.

TALL HIGH BROW OVALS

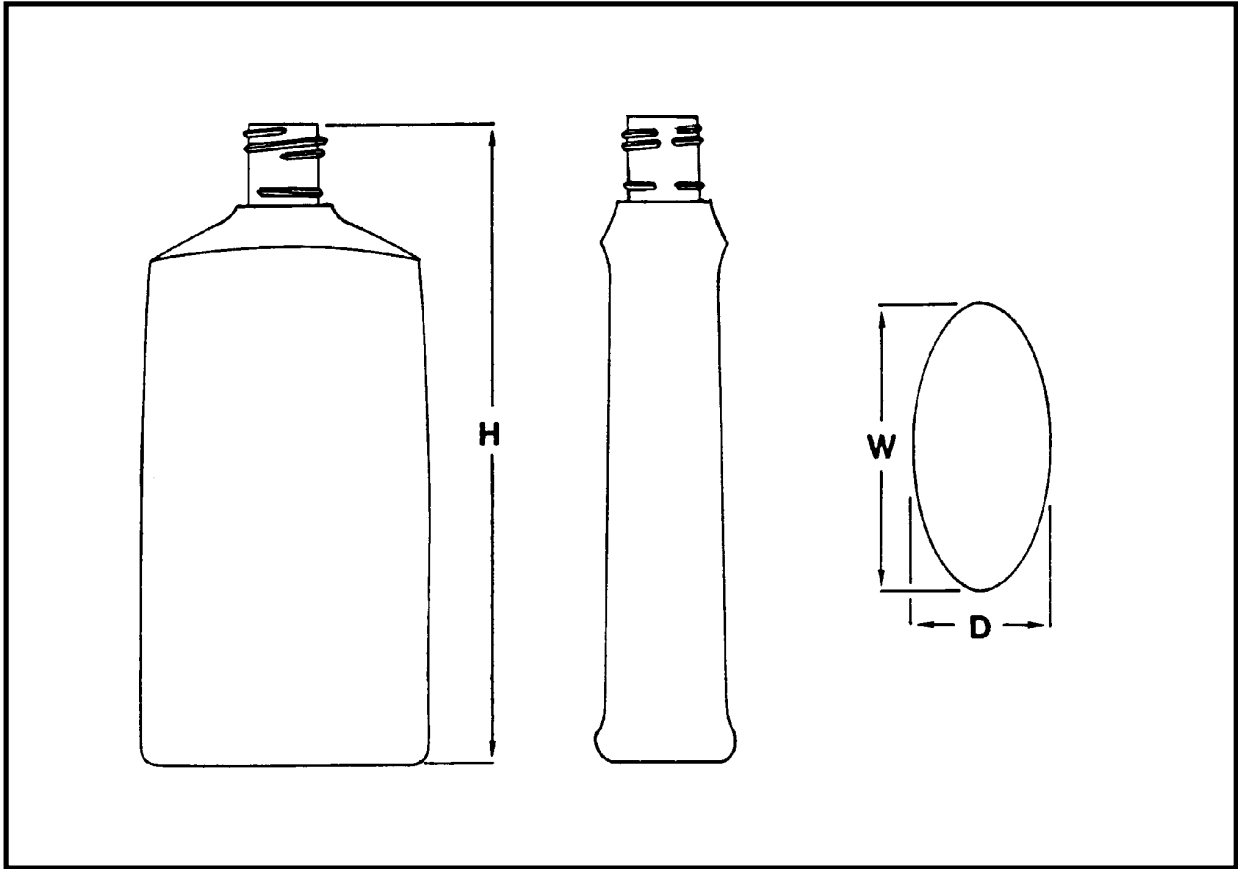

TALL HIGH BROW OVALS

CAPACITY	NECKS	MATERIAL	HEIGHT	WIDTH	DEPTH
32 oz	28mm Stull Push/Pull*	HDPE	9.643"	4.62"	2.35"
32 oz	28-410	HDPE	9.75"	4.62"	2.35"

*Stull Push/Pull Part #10-2053 / 10-2073 BND

TALL OVALS

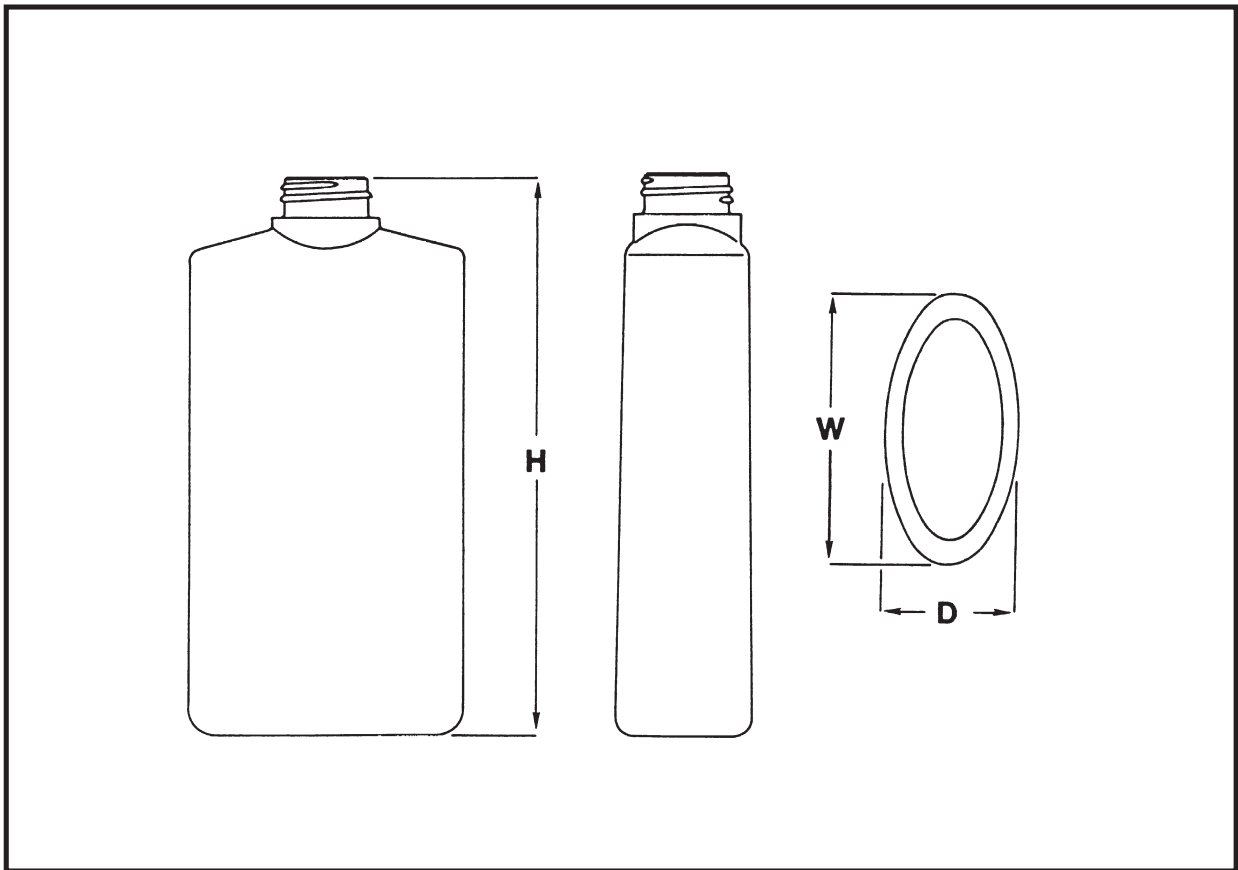

TALL OVALS

CAPACITY	NECKS	MATERIAL	HEIGHT	WIDTH	DEPTH
19 oz	33mm Magenta PopLok	HDPE	7.88"	3.92"	1.87"
19 oz	33-400	HDPE	8.08"	3.92"	1.87"

Available with and without view striping.

ORIGINAL LUDINGTON OVALS

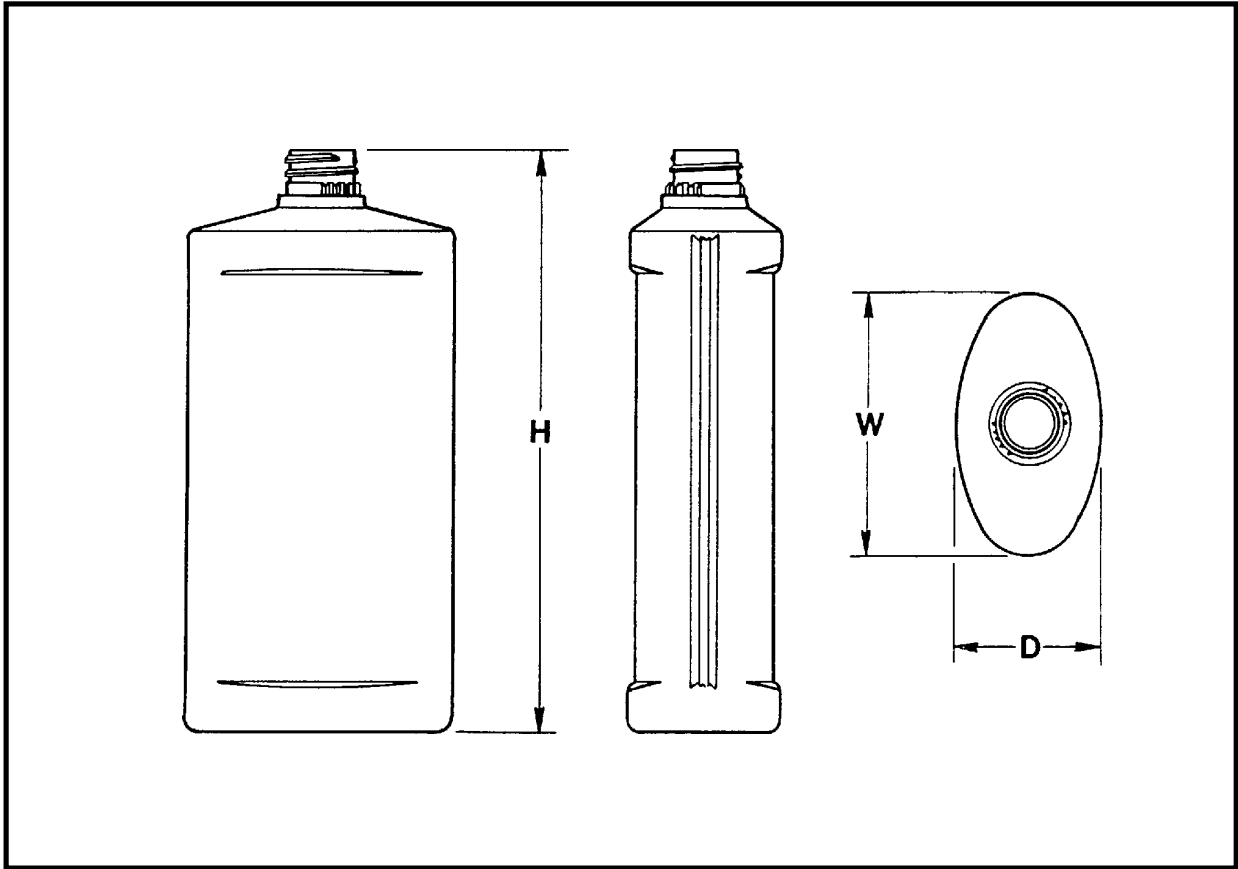

ORIGINAL LUDINGTON OVALS

CAPACITY	NECKS	MATERIAL	HEIGHT	WIDTH	DEPTH
24 oz / 27 oz	28-410	HDPE	8.86"	4.03"	2.30"
24 oz / 27 oz	28mm PS211	HDPE	8.81"	4.03"	2.30"
24 oz / 27 oz	33-400	HDPE	8.53"	4.03"	2.30"

Secondary capacity measurement represents fill point to base of neck.

NEW LUDINGTON OVAL

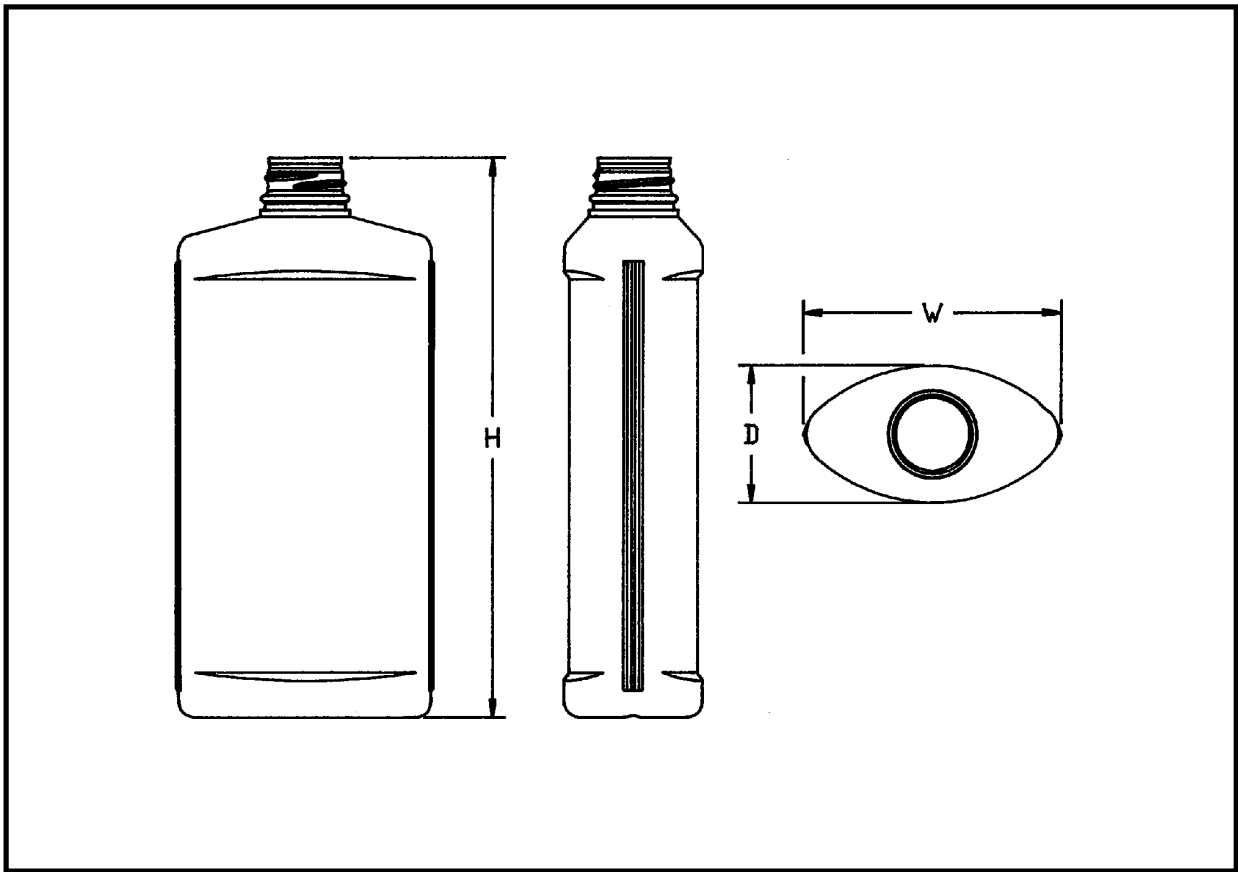

NEW LUDINGTON OVAL

CAPACITY	NECKS	MATERIAL	HEIGHT	WIDTH	DEPTH
24 oz	33-480	HDPE	8.843"	3.2"	2.174"

FLASK

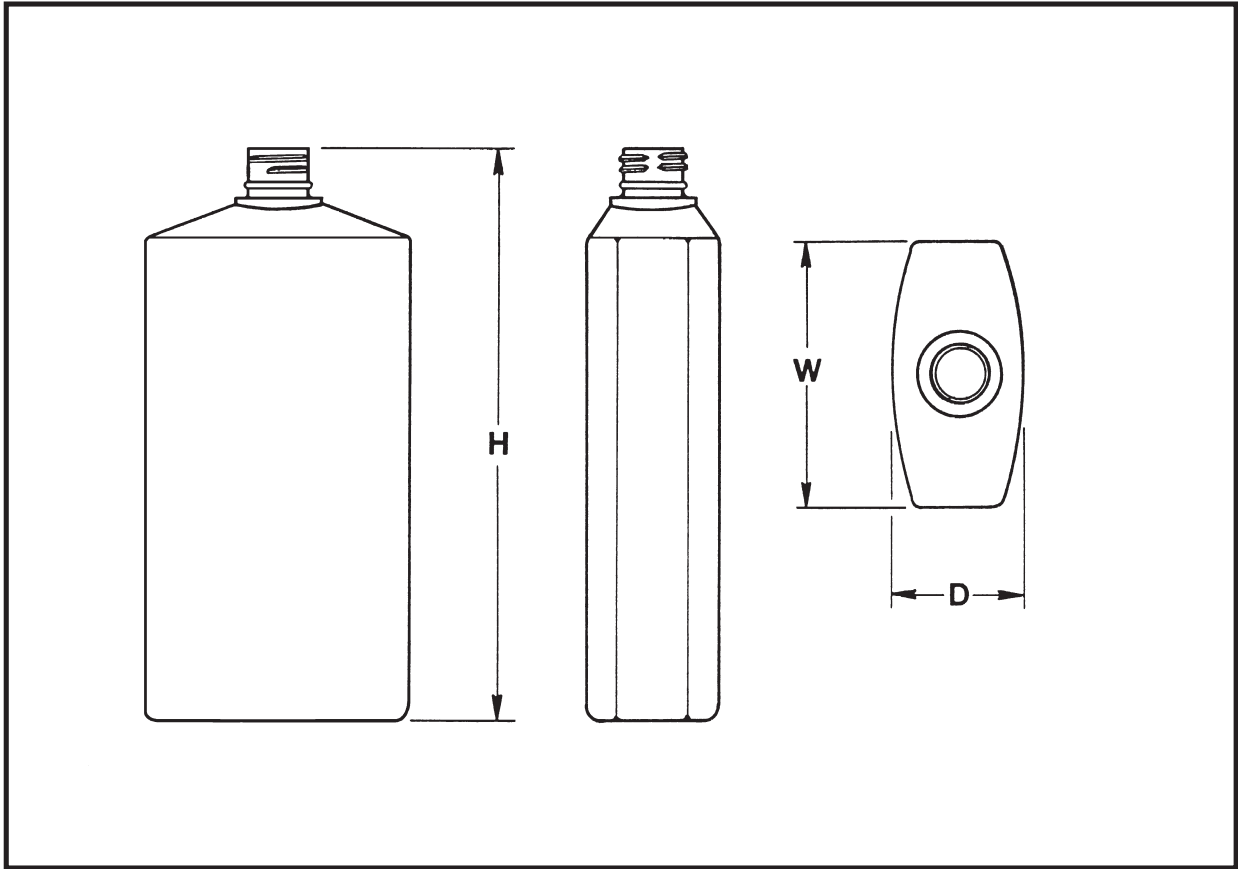

FLASK

CAPACITY	NECKS	MATERIAL	HEIGHT	WIDTH	DEPTH
20 oz	24-410	HDPE	8.11"	3.74"	1.85"

Available with and without view striping.

ROYAL OVALS

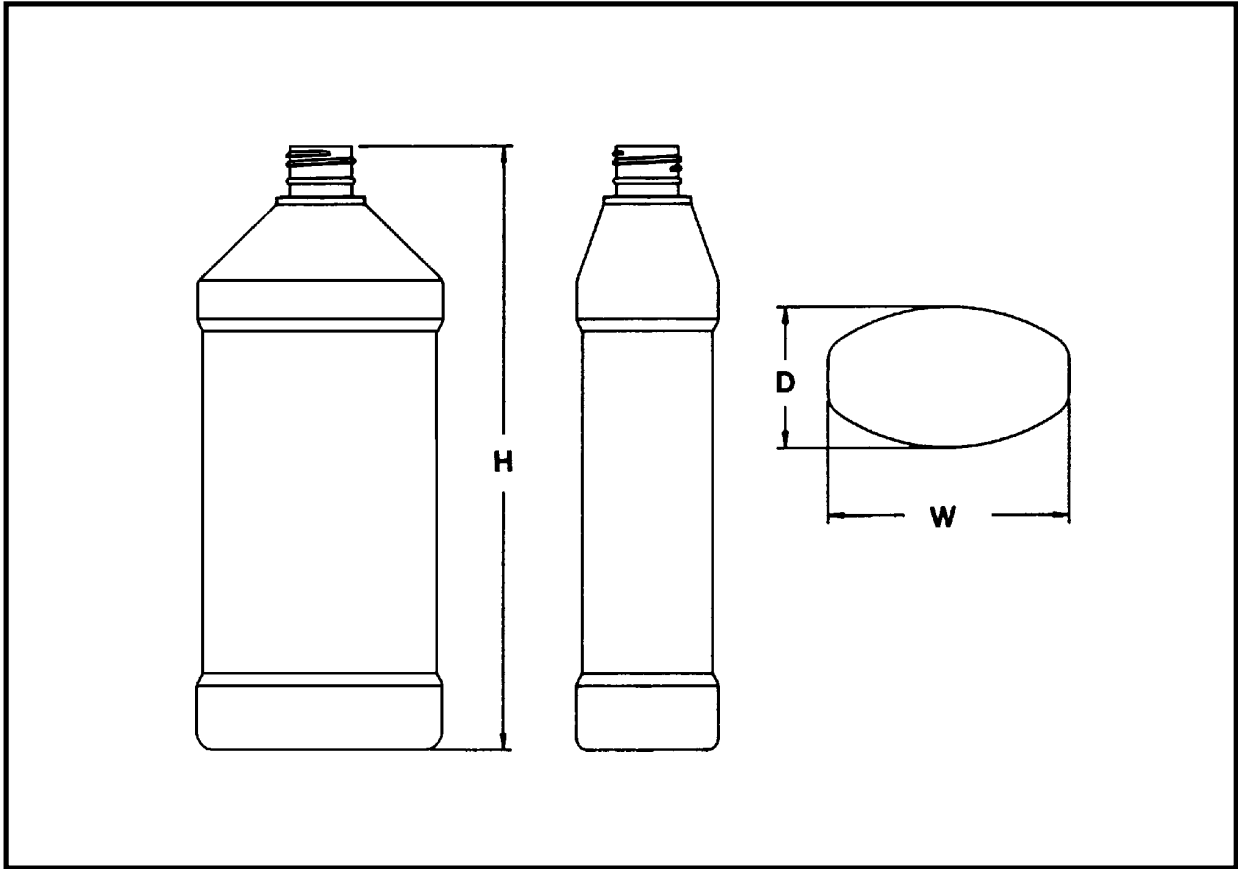

ROYAL OVALS

CAPACITY	NECKS	MATERIAL	HEIGHT	WIDTH	DEPTH
16 oz	28-410	PP or HDPE	8.34"	3.35"	1.90"
32 oz*	33-430	PVC	10.07"	4.73"	2.21"

*For a 50,000 piece order, we could look at building an OPET version.

ROYAL HANDLEWARE OVALS

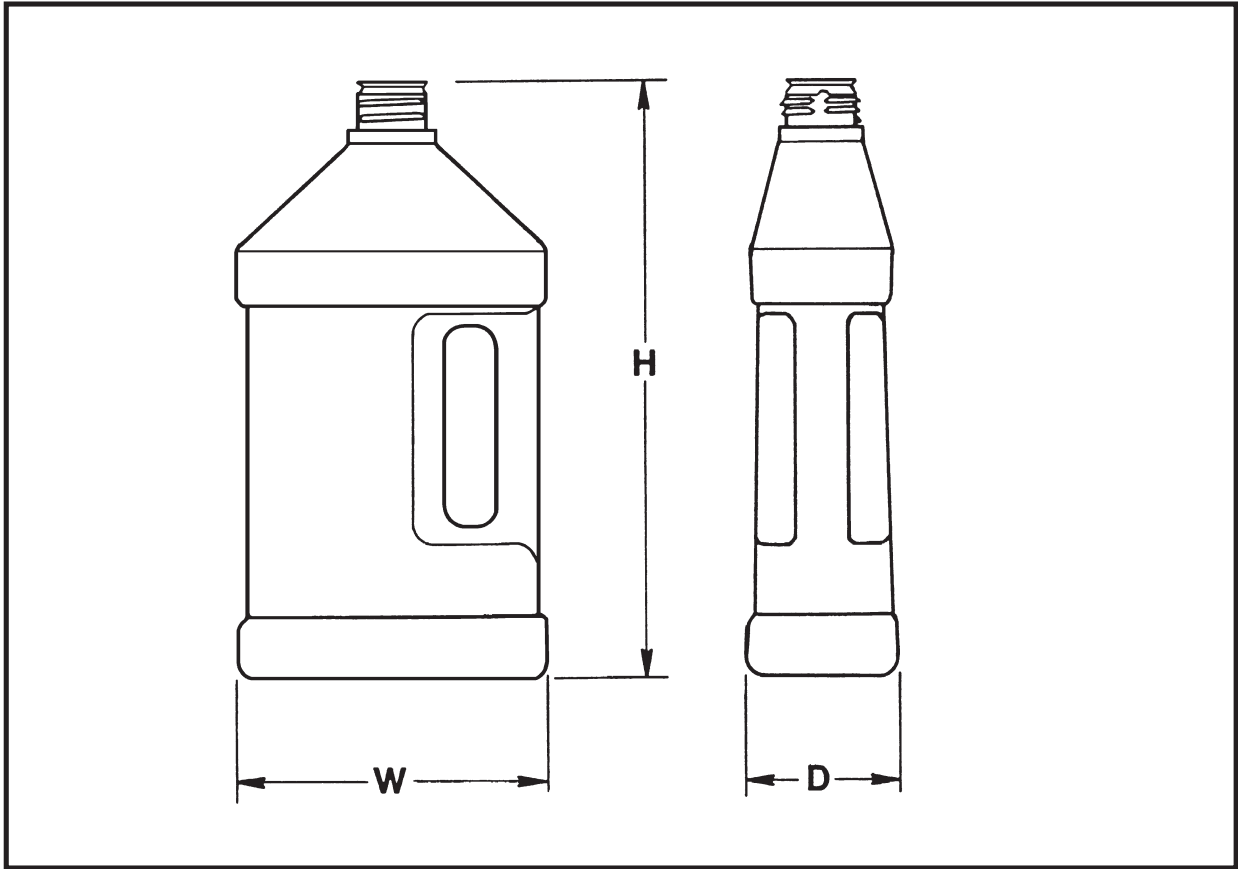

ROYAL HANDLEWARE OVALS

CAPACITY	NECKS	MATERIAL	HEIGHT	WIDTH	DEPTH
32 oz	33-430	PP	10.01"	5.11"	2.61"
32 oz	33-430	HDPE	10.01"	5.11"	2.61"

HANDLEWARE OVALS

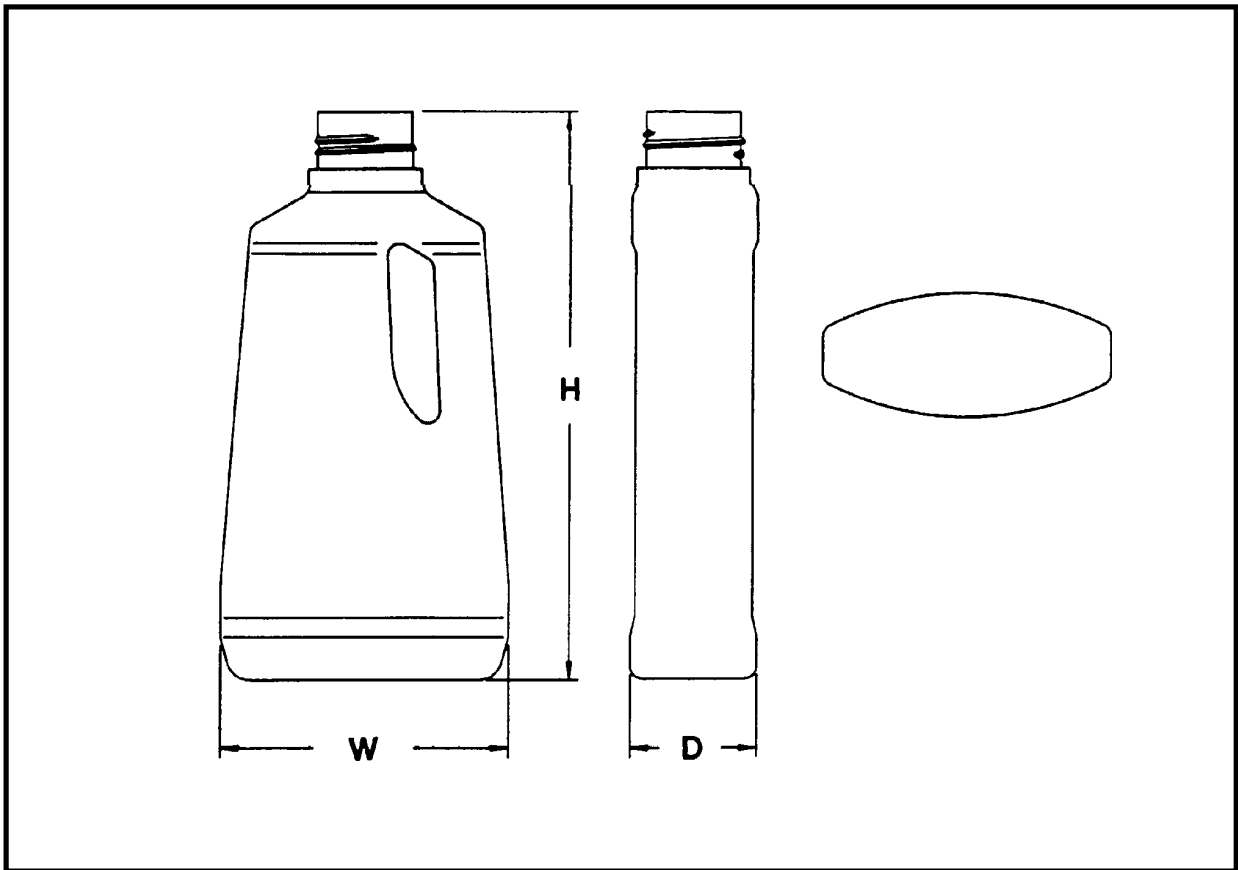

HANDLEWARE OVALS

CAPACITY	NECKS	MATERIAL	HEIGHT	WIDTH	DEPTH
22 oz*	33-430	PVC	8.93"	4.45"	1.96"
22 oz*	38-400	PVC	8.50"	4.45"	1.96"
22 oz*	38-430	PVC	8.93"	4.45"	1.96"
22 oz	38-430P	PVC	8.93"	4.45"	1.96"
22 oz*	40mm	PVC	9.06"	4.45"	1.96"

* Capacity of all containers is 22 oz liquid / 16 oz dry.

KLEAN-POUR® HANDLEWARE OVALS

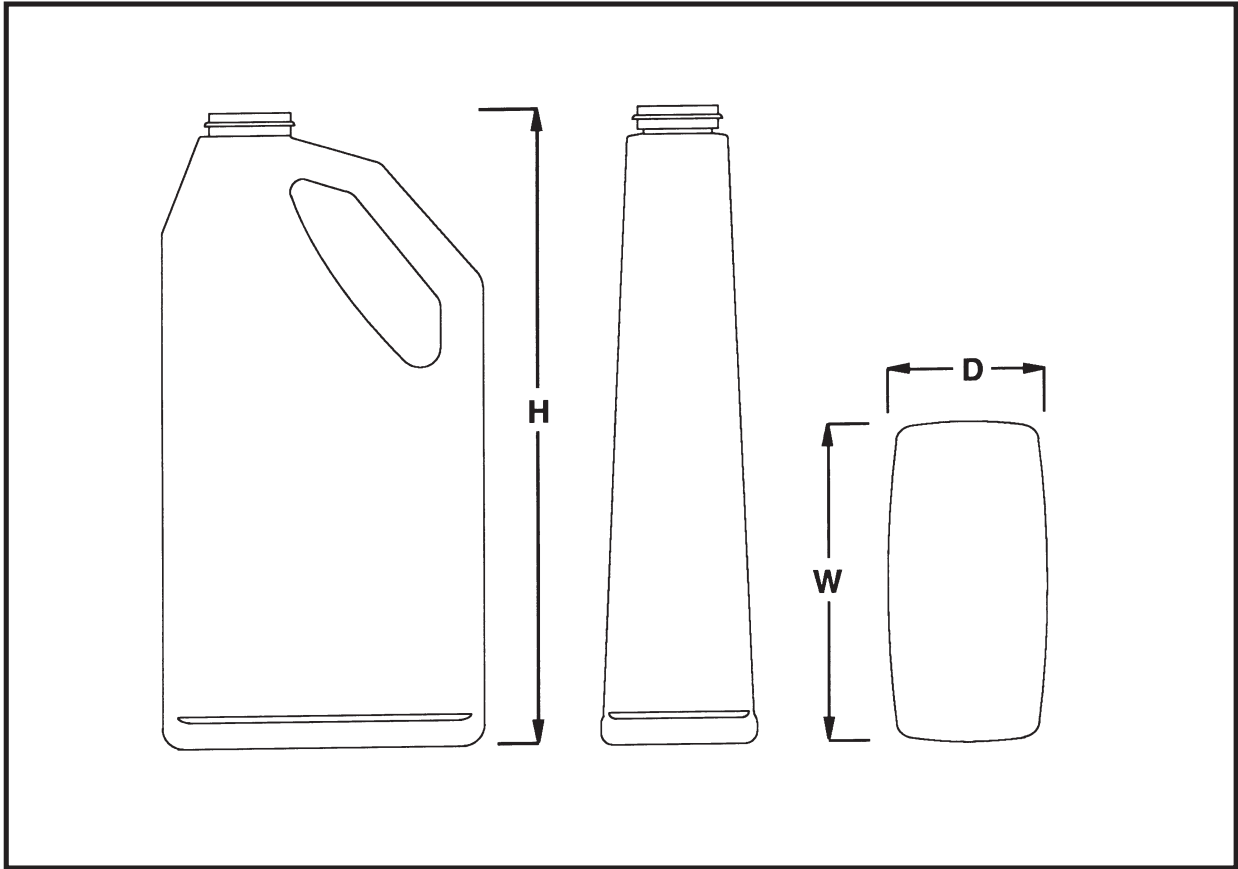

KLEAN-POUR® HANDLEWARE OVALS

CAPACITY	NECKS	MATERIAL	HEIGHT	WIDTH	DEPTH
32 oz/1 Liter*	33-400 Anti-Glug	HDPE	10.13"	5.08"	2.35"
64 oz/2 Liter	33-400 Anti-Glug	HDPE	10.60"	5.96"	3.78"

Design Patent #378,664.

* Available with and without customized inserts.

KLEAN-POUR® II HANDLEWARE OVAL

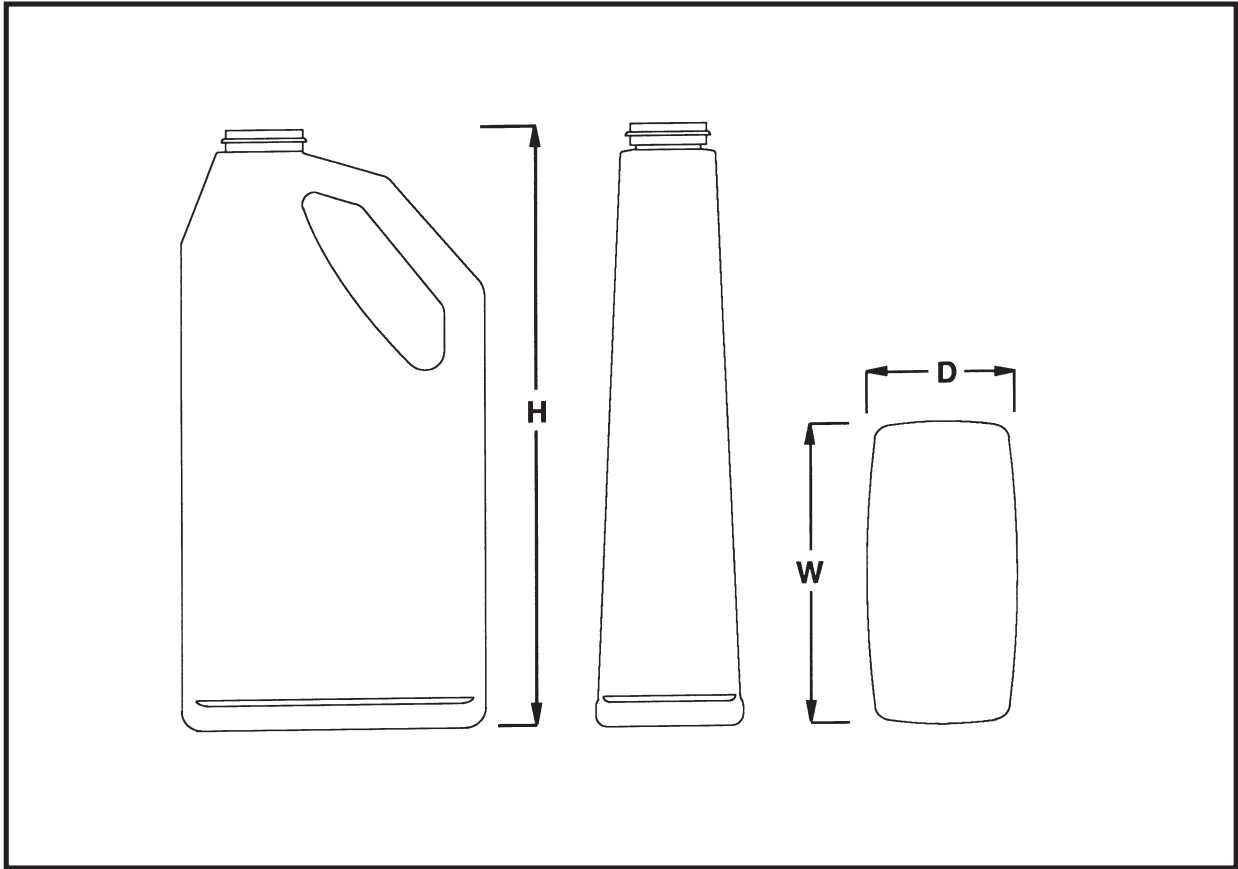

KLEAN-POUR® II HANDLEWARE OVAL

CAPACITY	NECKS	MATERIAL	HEIGHT	WIDTH	DEPTH
64 oz/2 Liter	33-400 Anti-Glug	HDPE	10.60"	5.96"	3.50"

Design Patent #378,664.

AWARD HANDLEWARE OVAL

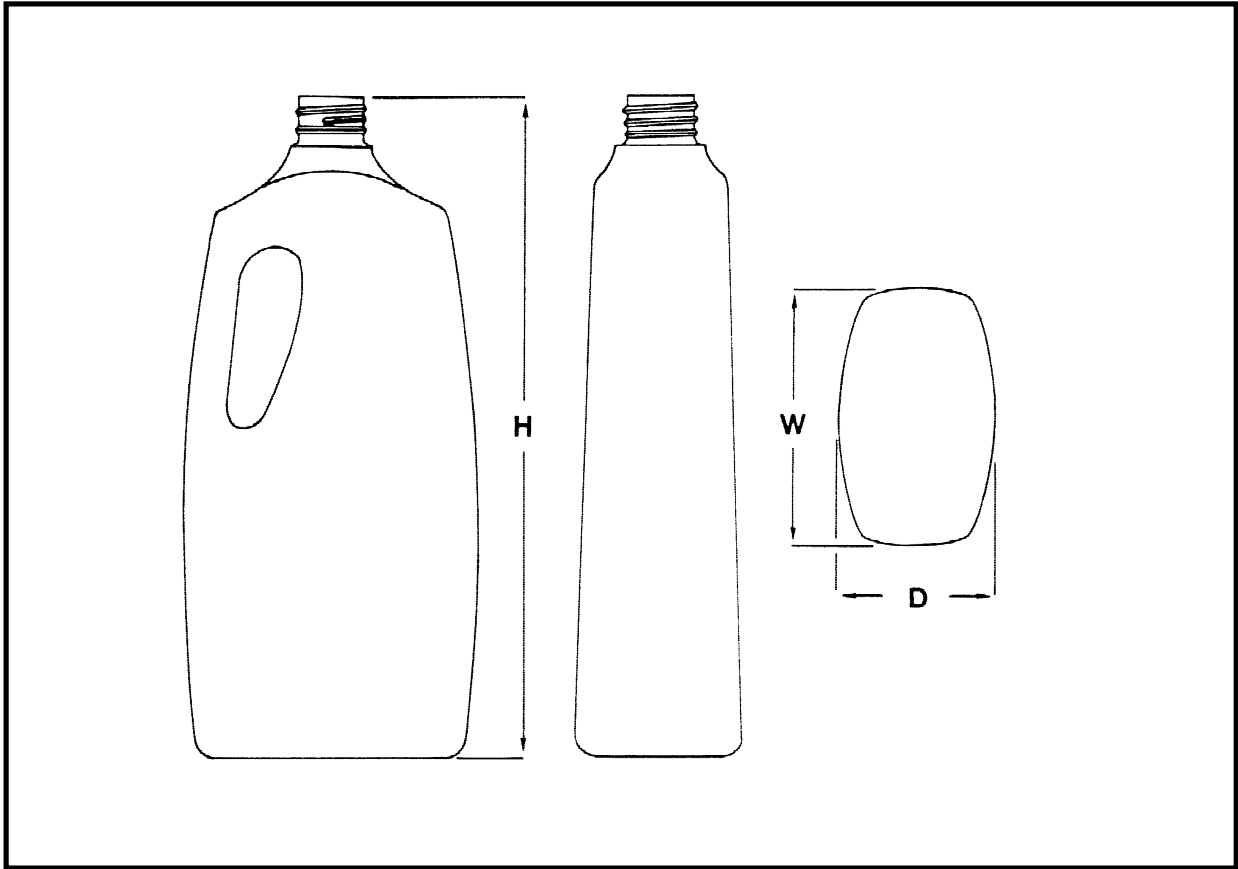

AWARD HANDLEWARE OVAL

CAPACITY	NECKS	MATERIAL	HEIGHT	WIDTH	DEPTH
32 oz	28-410	HDPE	10.22"	4.54"	2.58"
64 oz	28-410	HDPE	11.73"	5.99"	3.21"

WAVE GRIPPED OVAL

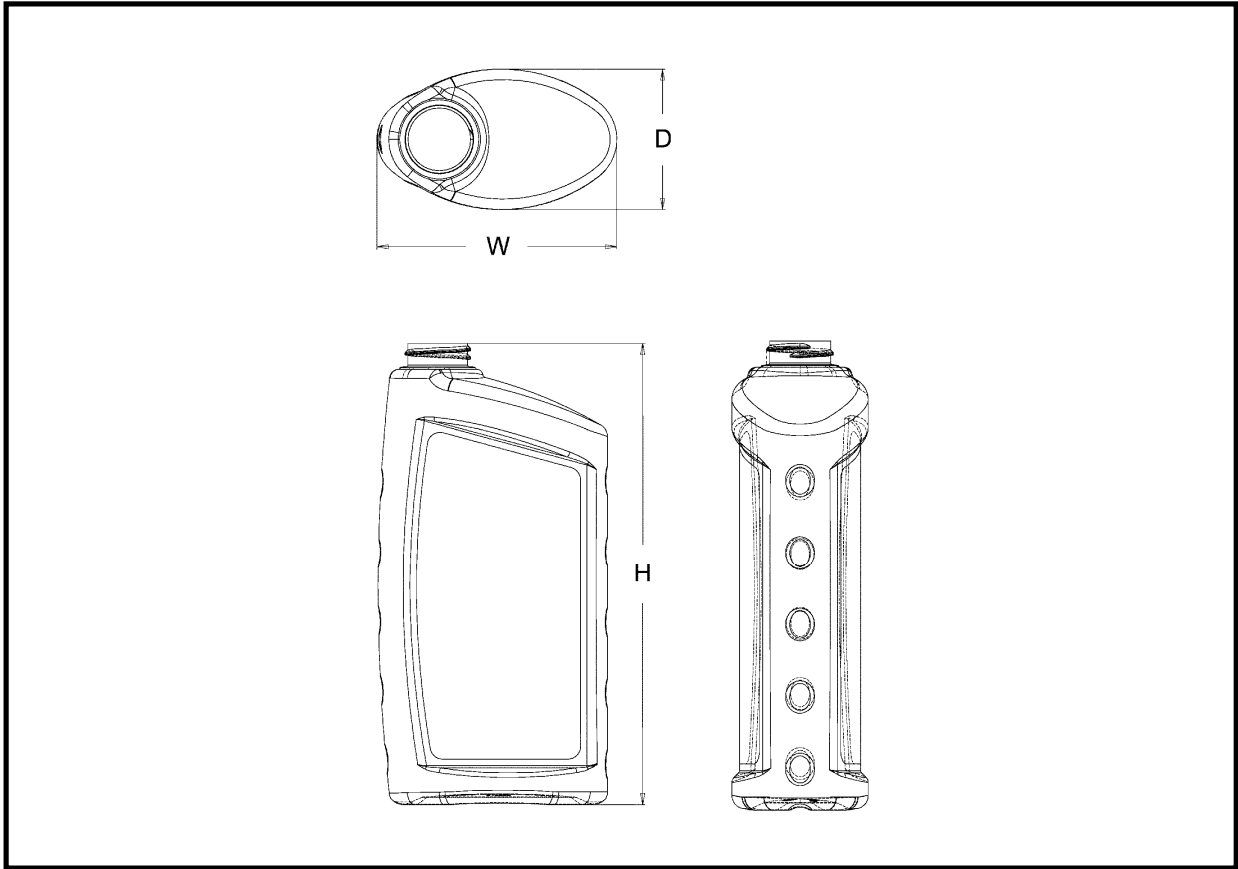

WAVE GRIPPED OVAL

CAPACITY	NECKS	MATERIAL	HEIGHT	WIDTH	DEPTH
32 oz	33-400	HDPE	8.93"	4.45"	2.60"

PLASTIC BOTTLE CORPORATION

28055 North Ashley Circle, Suite 110
Libertyville, IL 60048-9635
847-367-1900
Fax: 847-367-1990
www.plasticbottle.com



OBLONGS

Where great ideas take shape.

BEVELED OBLONG

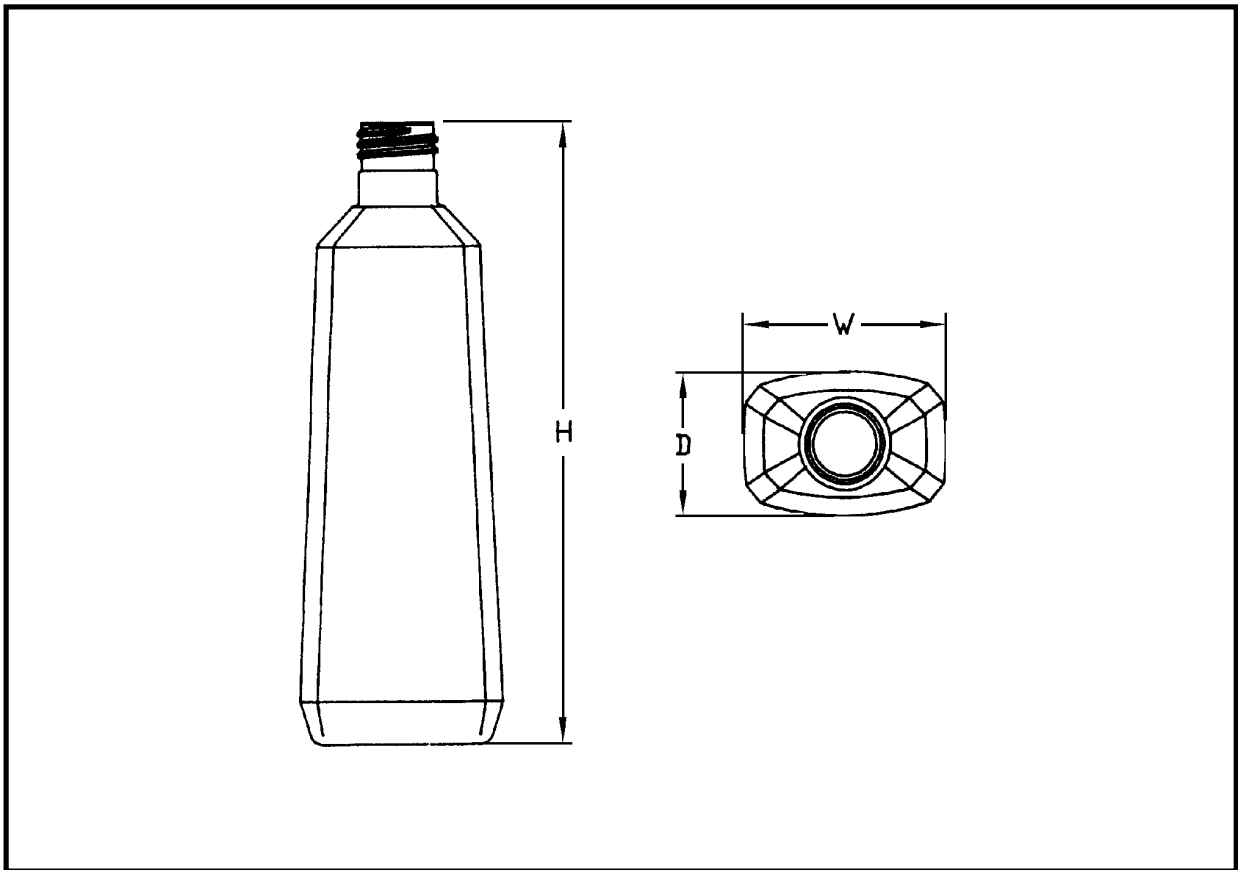

BEVELED OBLONG

CAPACITY	NECKS	MATERIAL	HEIGHT	WIDTH	DEPTH
2 oz**	20-415	PVC	5.212"	1.468"	1.037"
4 oz**	22mm PDG*	PVC	6.186"	1.849"	1.305"
6 oz	24-410	HDPE	6.491"	1.975"	1.579"
8 oz**	24-415	PVC	7.27"	2.38"	1.68"

* Uses Special Tall "H" Closure.

**For a 50,000 piece order, we could look at building an OPET version.

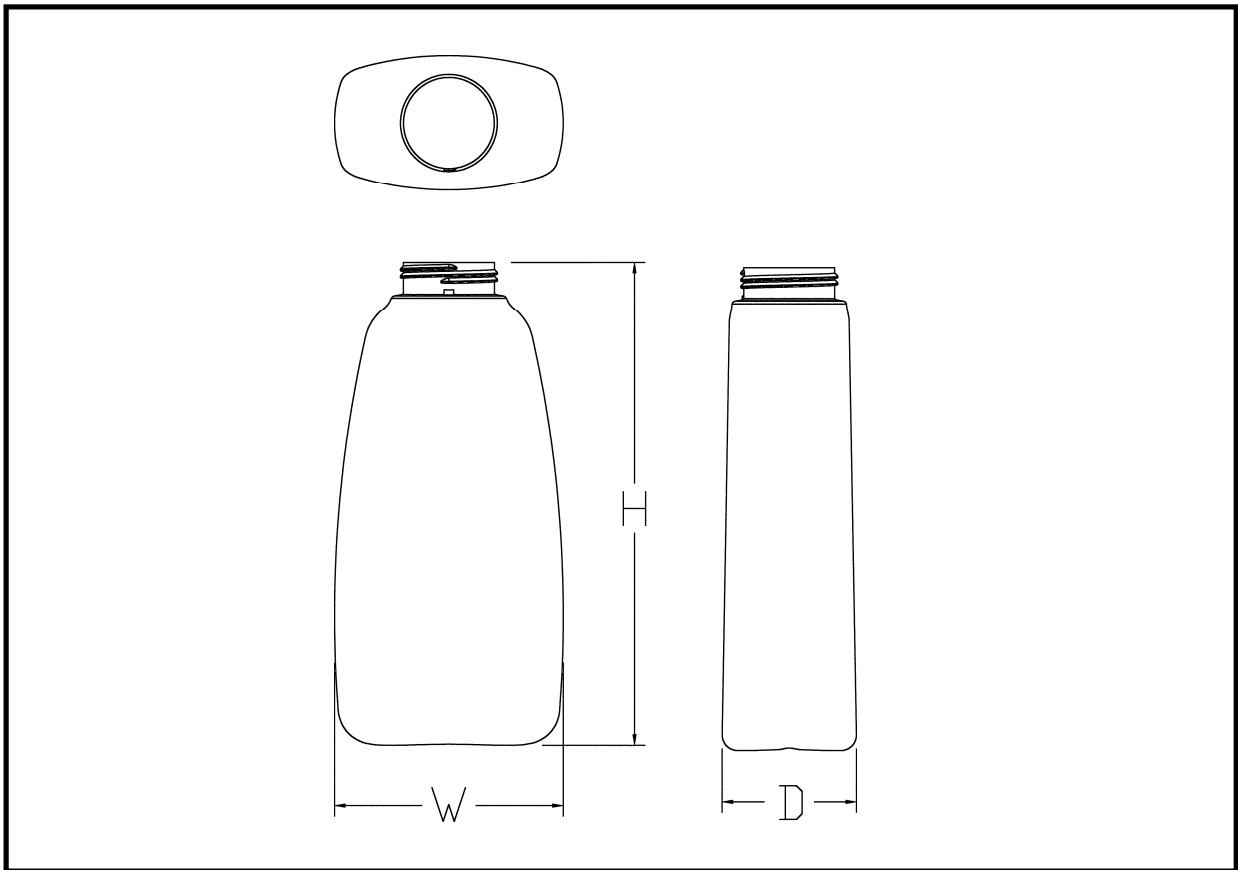
ECLIPSE OBLONG**ECLIPSE OBLONG**

CAPACITY	NECKS	MATERIAL	HEIGHT	WIDTH	DEPTH
8 oz / 250 ml	30mm Foamer	HDPE	5.865"	2.771"	1.627"

SPICER OBLONG

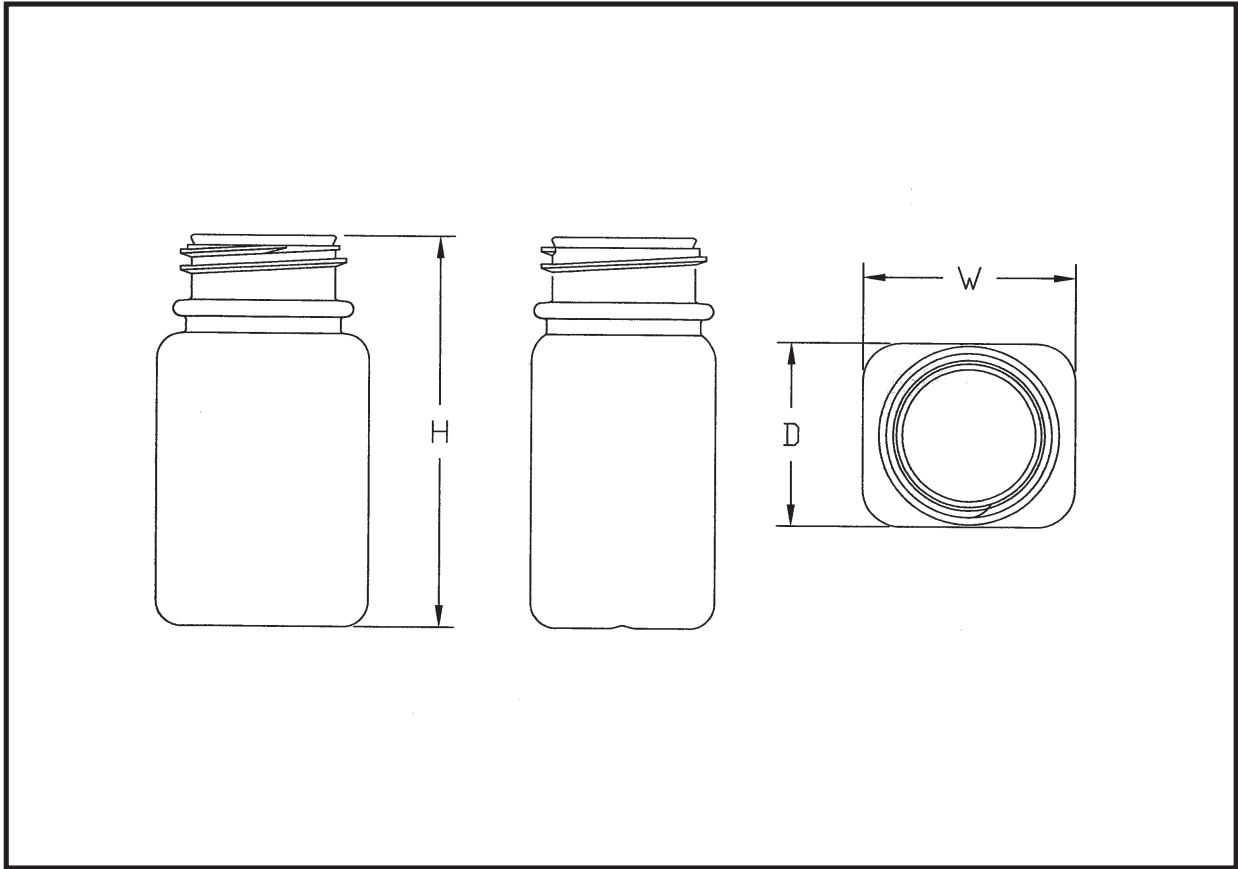

SPICER OBLONG

CAPACITY	NECKS	MATERIAL	HEIGHT	WIDTH	DEPTH
6 oz	43-485	PETG	3.892"	2.10"	1.83"

EZ GRIP OBLONGS

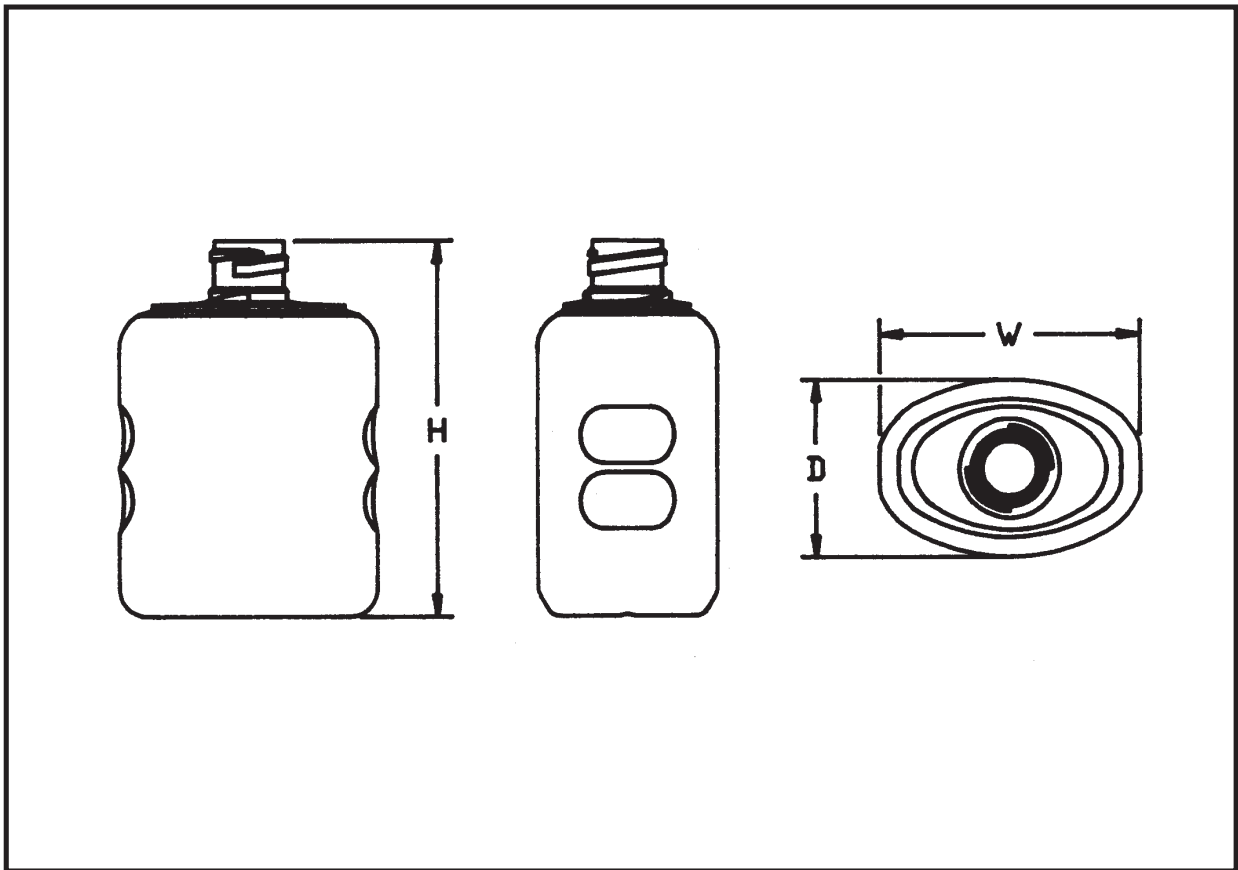

EZ GRIP OBLONGS

CAPACITY	NECKS	MATERIAL	HEIGHT	WIDTH	DEPTH
350 ml	24-410	HDPE	4.751"	3.40"	2.37"
350 ml	24-415	HDPE	5.01"	3.40"	2.37"
350 ml	28-400	HDPE	4.97"	3.40"	2.37"
440 ml	24-410	HDPE	5.621"	3.40"	2.37"
440 ml	24-415	HDPE	5.88"	3.40"	2.37"
440 ml	28-400	HDPE	5.48"	3.40"	2.37"

Number of finger grips change with size (350 ml shown above)

EZ GRIP OBLONGS

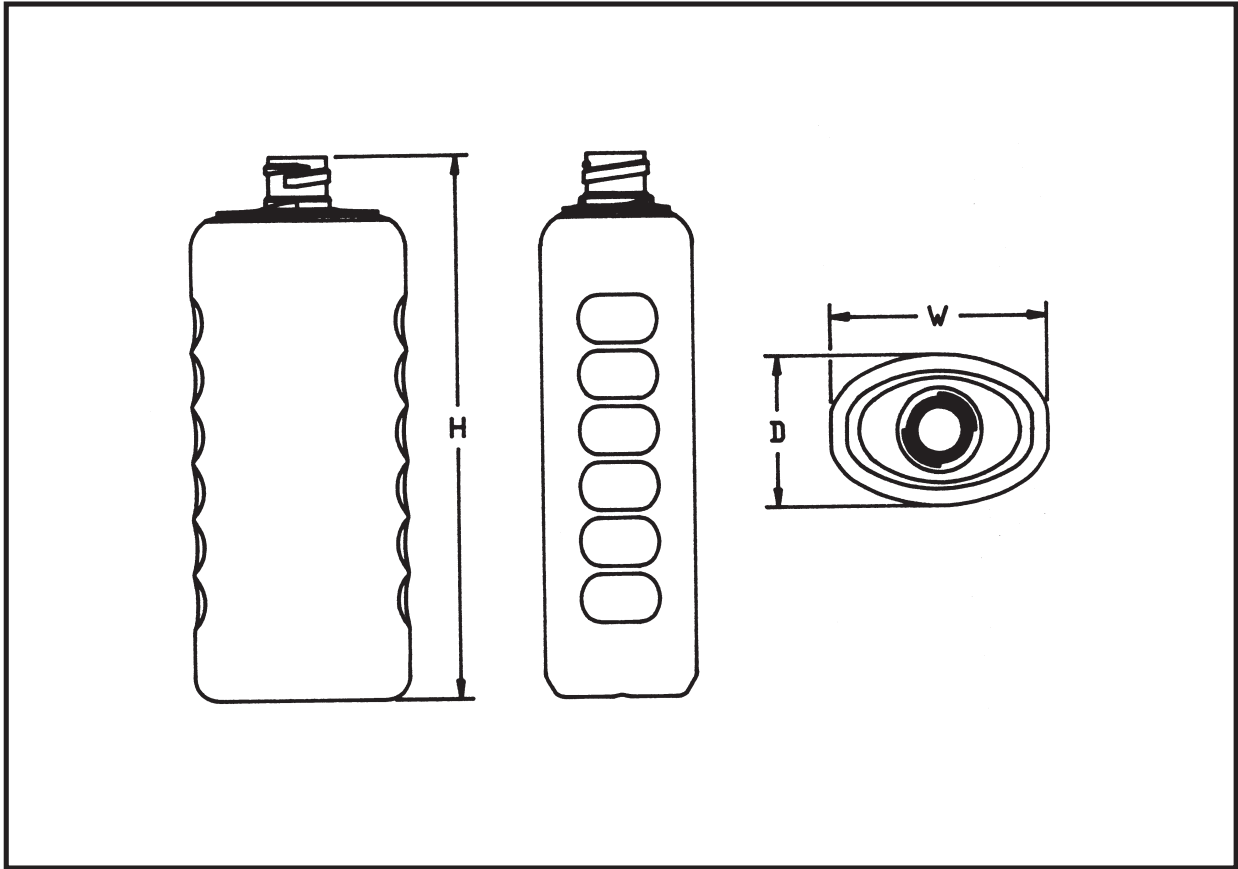

EZ GRIP OBLONGS

CAPACITY	NECKS	MATERIAL	HEIGHT	WIDTH	DEPTH
530 ml	24-410	HDPE	6.421"	3.40"	2.37"
530 ml	24-415	HDPE	6.68"	3.40"	2.37"
530 ml	28-400	HDPE	6.36"	3.40"	2.37"
700 ml	24-410	HDPE	8.431"	3.40"	2.37"
700 ml	24-415	HDPE	8.69"	3.40"	2.37"
700 ml	28-400	HDPE	8.14"	3.40"	2.37"

Number of finger grips change with size (700 ml shown above)

GRADUATED OBLONGS

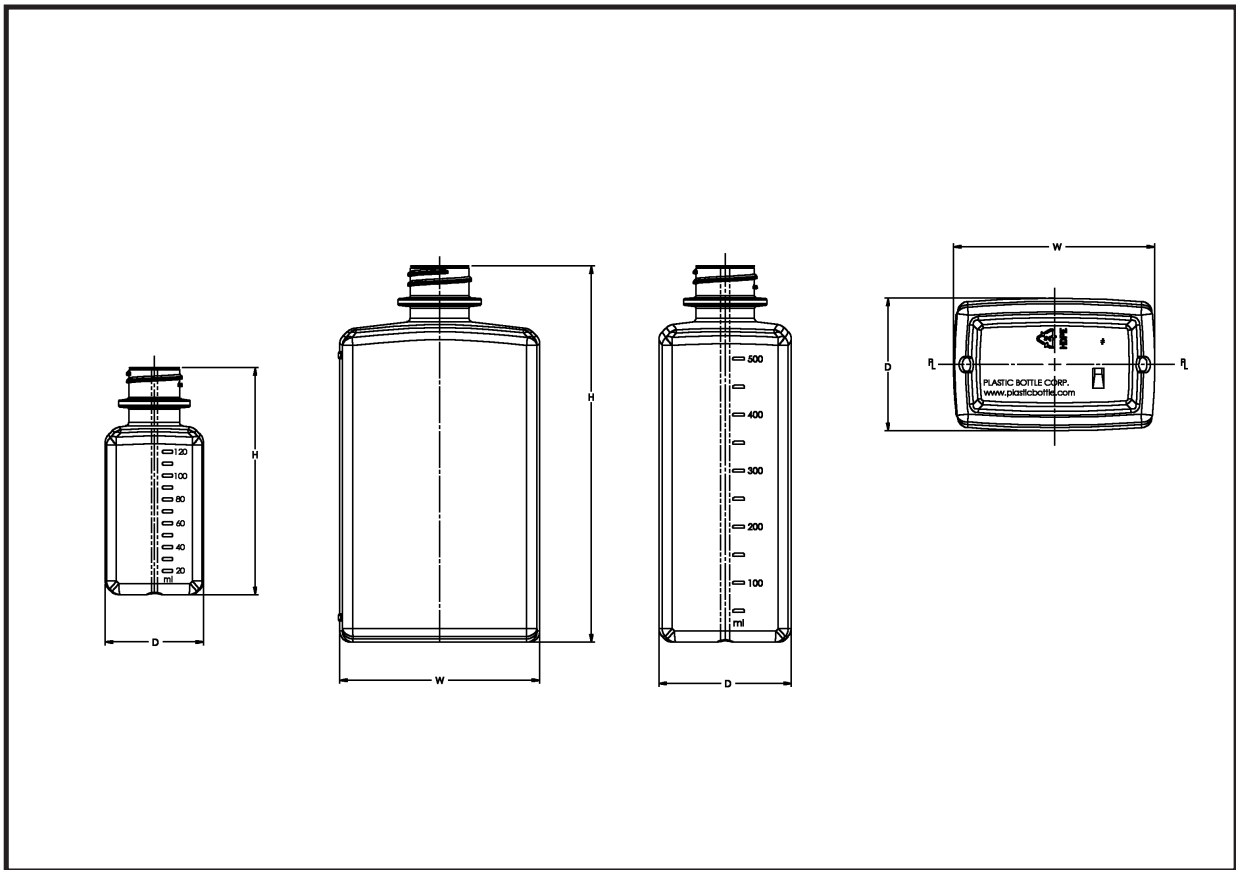

GRADUATED OBLONGS

CAPACITY	NECKS	MATERIAL	HEIGHT	WIDTH	DEPTH
4 oz / 120 ml	24-400 .530" H	HDPE	3.81"	2.10"	1.65"
16 oz / 500 ml	28-400 .530" H	HDPE	6.31"	3.36"	2.225"

Available with and without view striping.

IDEAL OBLONG

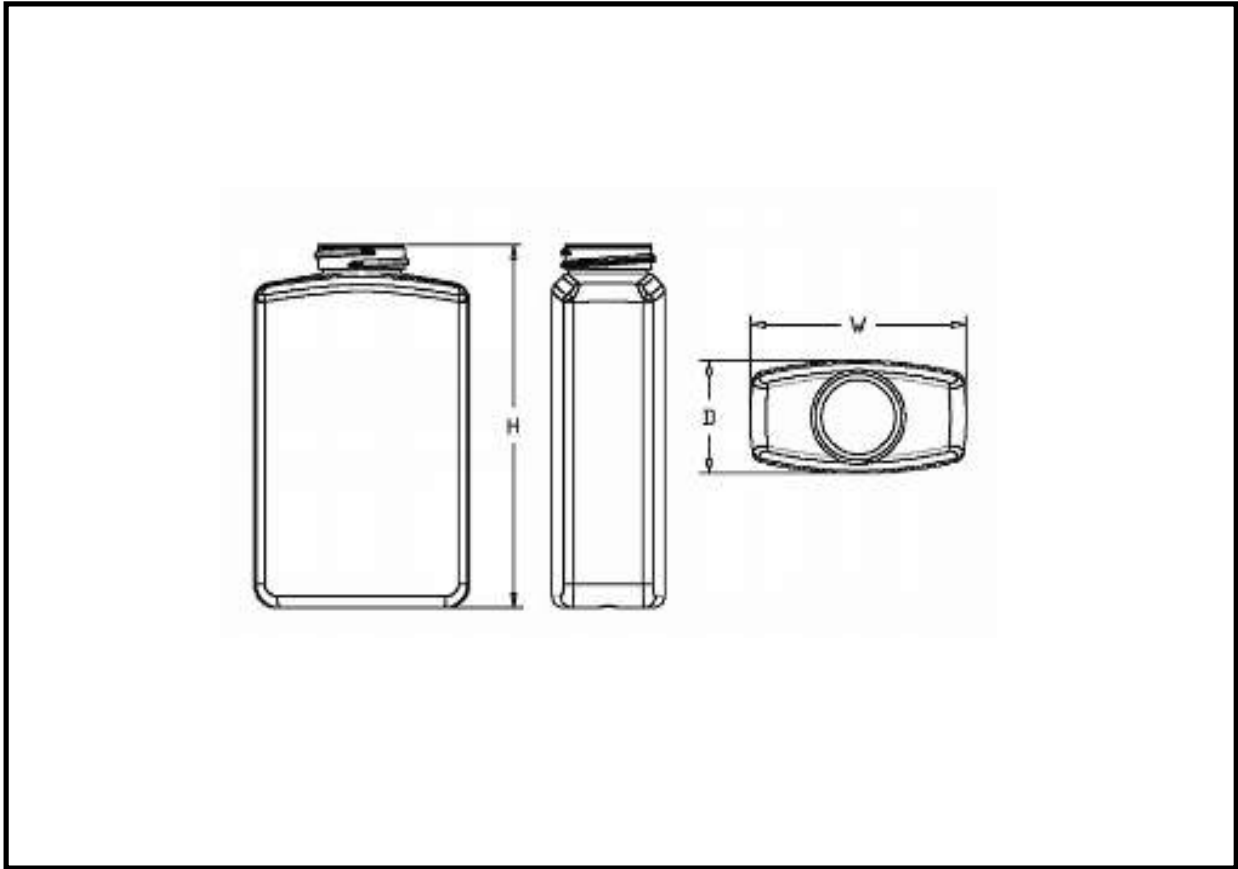

IDEAL OBLONG

CAPACITY	NECKS	MATERIAL	HEIGHT	WIDTH	DEPTH
8 oz / 250 ml	33-400	HDPE	4.829"	2.875"	1.5"

IDEAL OBLONG

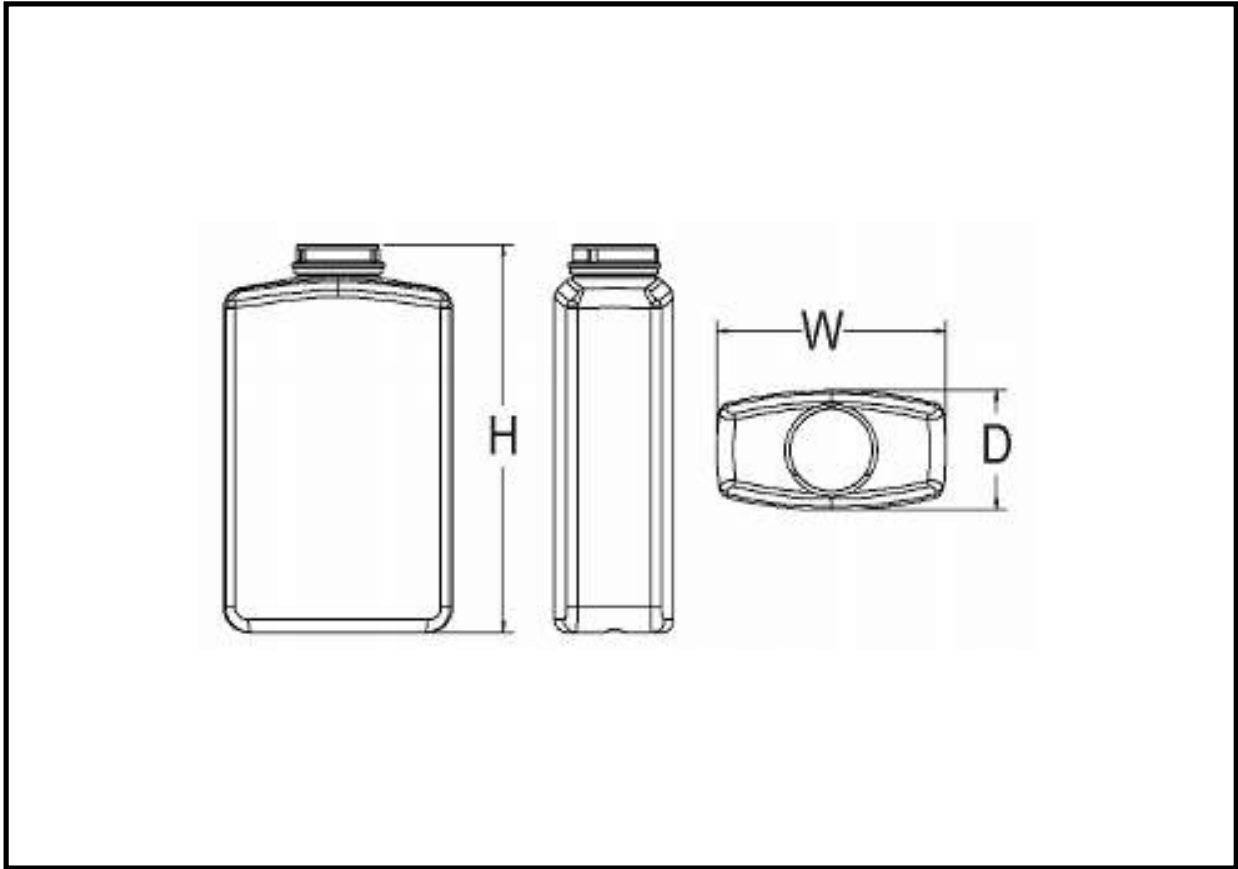

IDEAL OBLONG

CAPACITY	NECKS	MATERIAL	HEIGHT	WIDTH	DEPTH
8 oz / 250 ml	33mm PTI Sifter	HDPE	4.86"	2.875"	1.5"

COSMOPOLITAN OBLONG

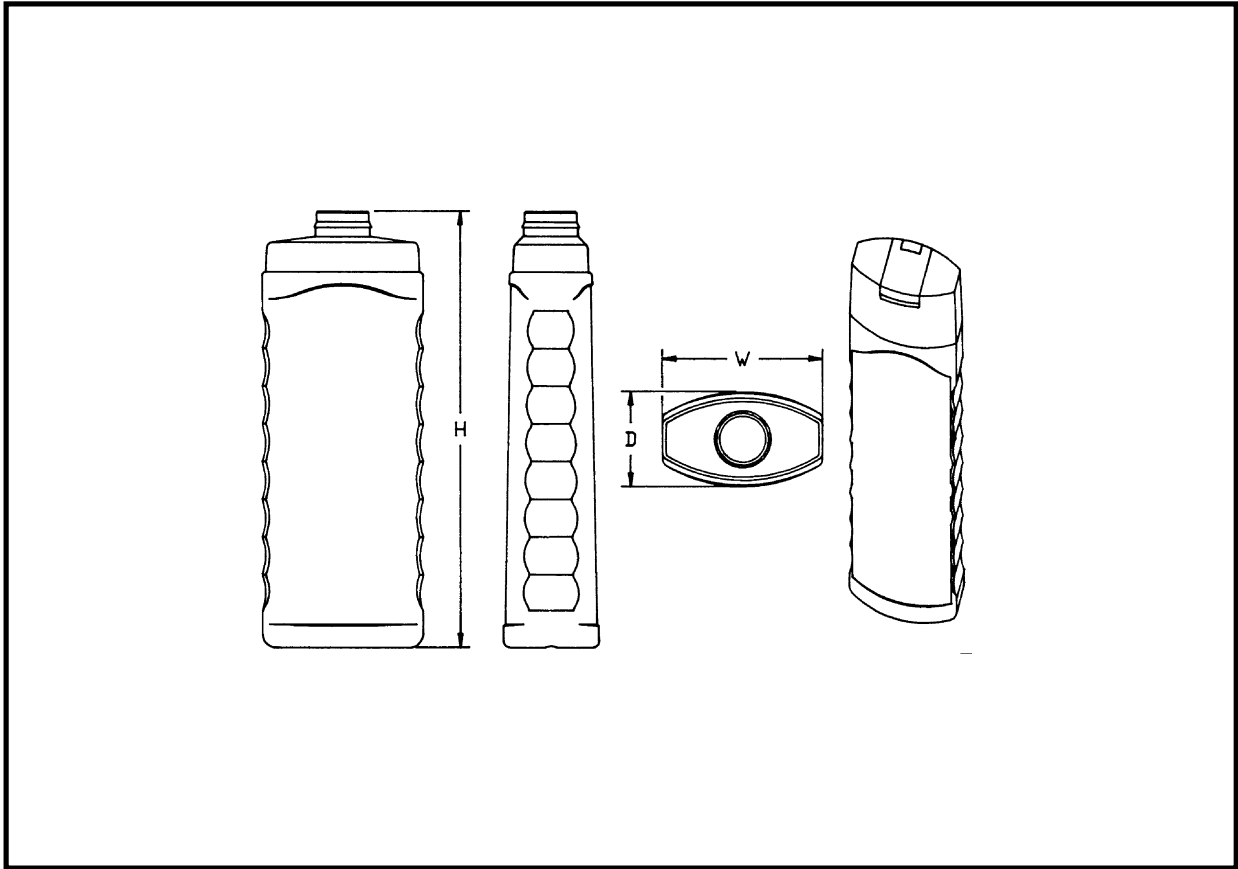

COSMOPOLITAN OBLONG

CAPACITY	NECKS	MATERIAL	HEIGHT	WIDTH	DEPTH
13.5 oz	26mm Snap-On	PVC	7.88"	2.91"	1.72"

Patent No.: US D472,153 S

MEMPHIS OBLONG

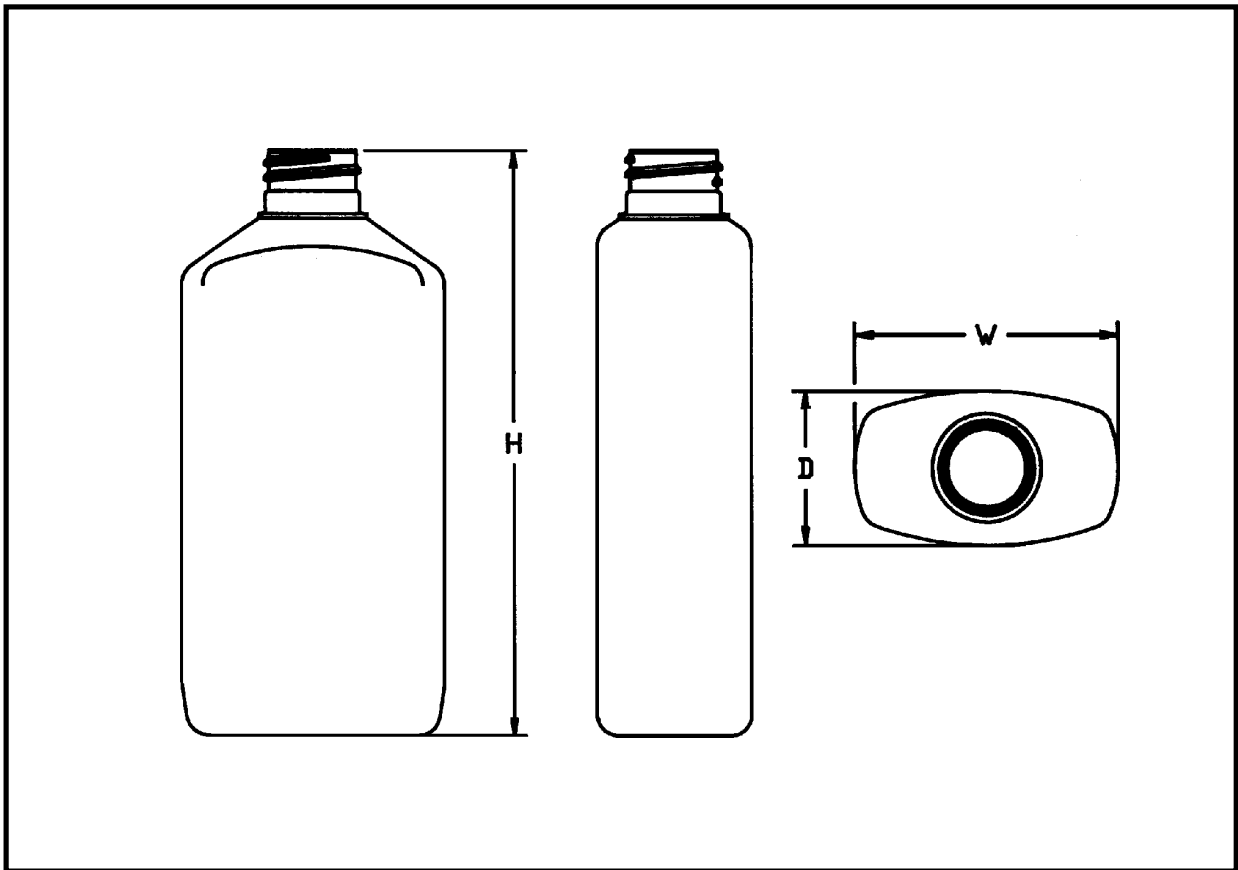

MEMPHIS OBLONG

CAPACITY	NECKS	MATERIAL	HEIGHT	WIDTH	DEPTH
13 oz	28-410	PVC or PETG	6.63"	2.98"	1.75"
15 oz	28-410	OPET	7.00"	2.98"	1.92"
15 oz	28-415	OPET	7.37"	2.98"	1.92"

HS OBLONGS

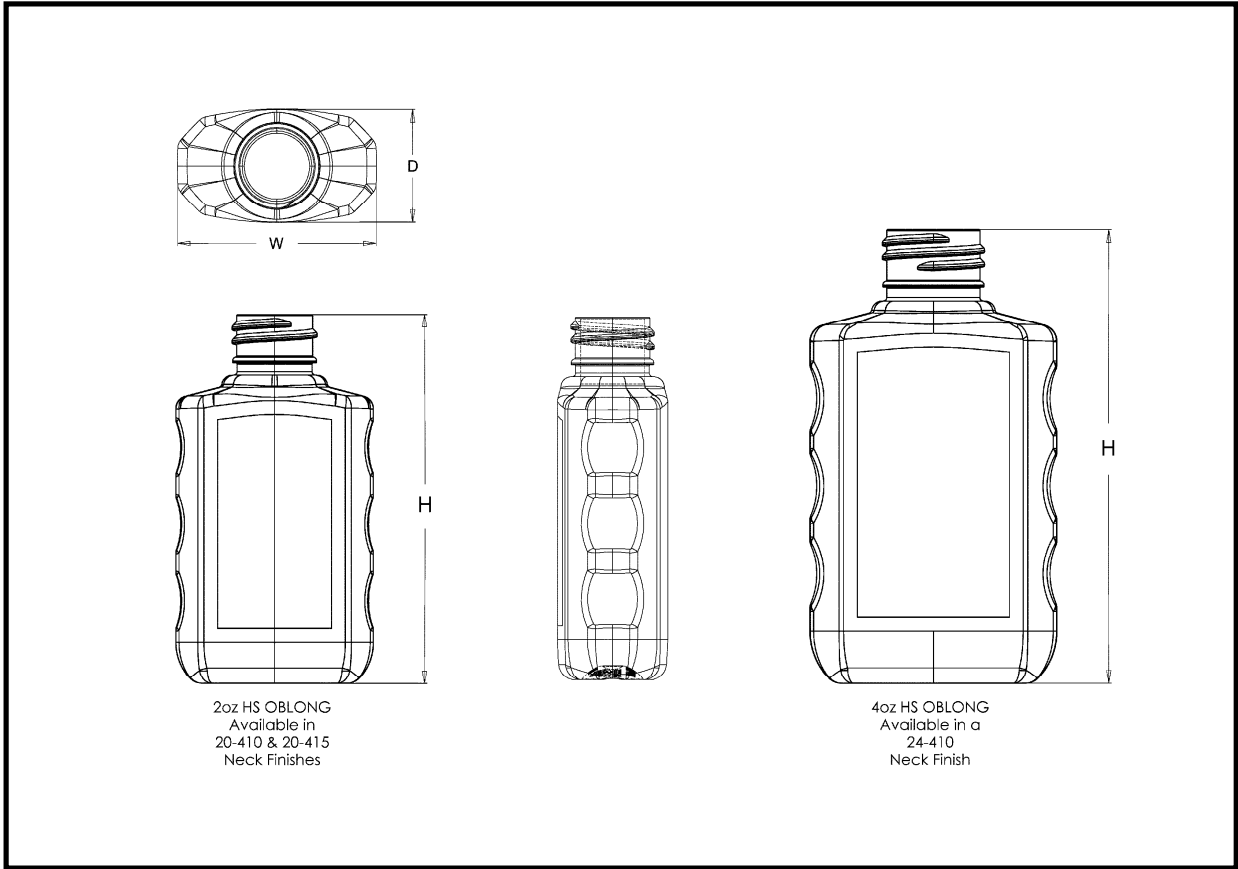

HS OBLONGS

CAPACITY	NECKS	MATERIAL	HEIGHT	WIDTH	DEPTH
2 oz	20-410	OPET	3.354"	1.80"	1.02"
2 oz	20-415	OPET	3.542"	1.80"	1.02"
4 oz	24-410	OPET	4.123"	2.25"	1.315"

HS OBLONG

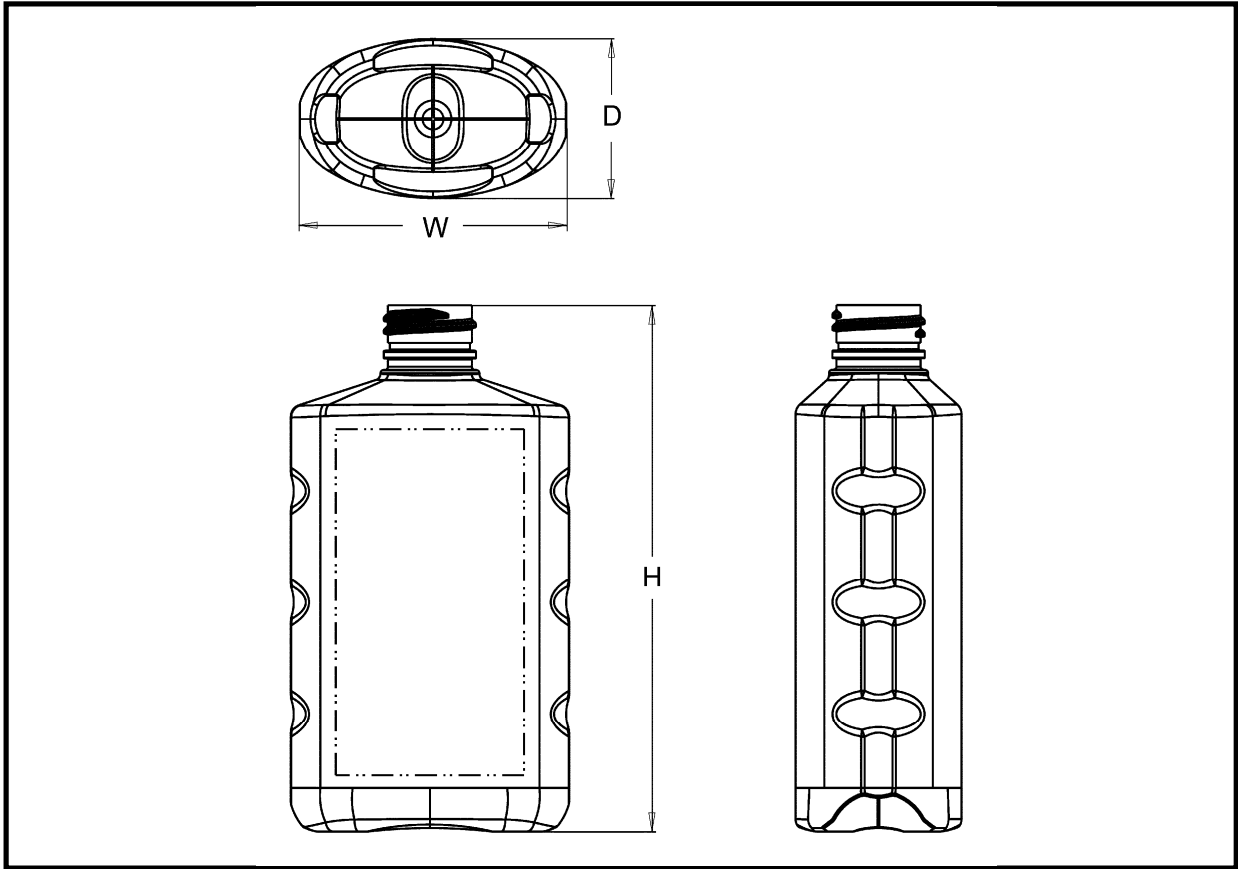

HS OBLONG

CAPACITY	NECKS	MATERIAL	HEIGHT	WIDTH	DEPTH
8 oz	24-410	OPET	5.30"	2.81"	1.675"

CUSTOM OBLONG

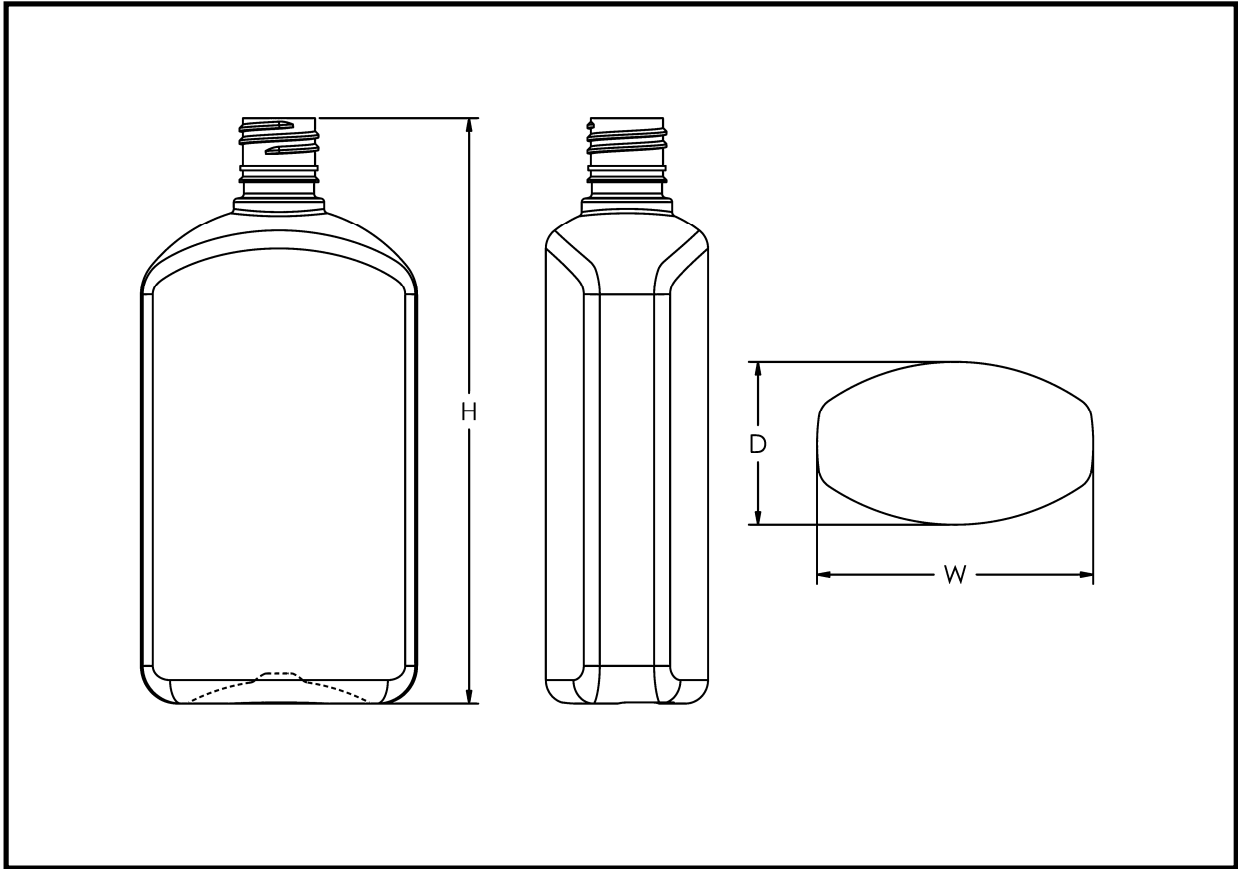

CUSTOM OBLONG

CAPACITY	NECKS	MATERIAL	HEIGHT	WIDTH	DEPTH
22 oz	28-415	OPET	7.989"	3.77"	2.214"

ELITE OBLONG

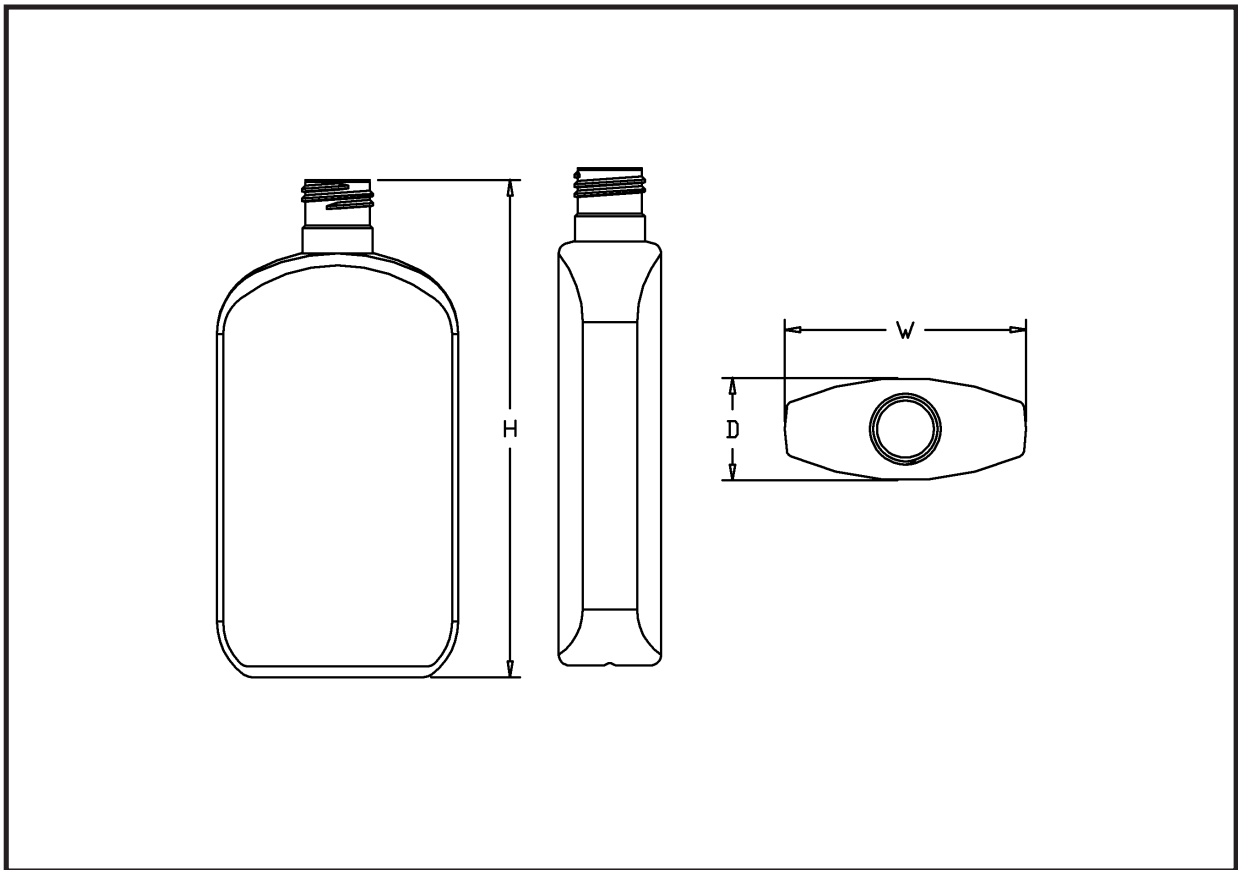

ELITE OBLONG

CAPACITY	NECKS	MATERIAL	HEIGHT	WIDTH	DEPTH
8 oz / 250 ml	24-410	HDPE	6.29"	3.18"	1.35"
8 oz / 250 ml	24-415	HDPE	6.55"	3.18"	1.35"

28055 North Ashley Circle, Suite 110
 Libertyville, IL 60048-9635
 847-367-1900
 Fax: 847-367-1990
www.plasticbottle.com

SIERRA OBLONG

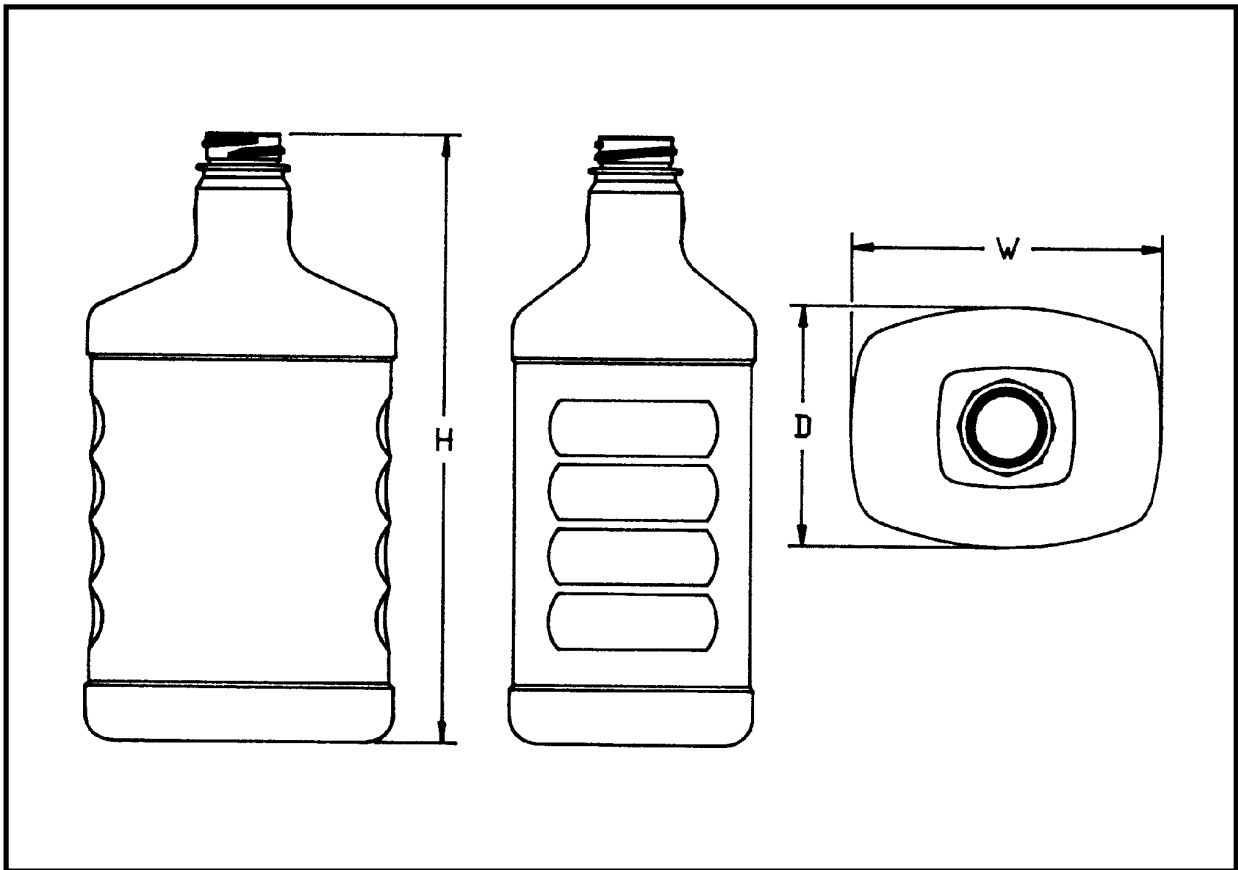

SIERRA OBLONG

CAPACITY	NECKS	MATERIAL	HEIGHT	WIDTH	DEPTH
16 oz / 500 ml	28-400	OPET	6.377"	3.34"	2.62"
32 oz / 1 Liter	28-400T .460" H	OPET	8.305"	4.15"	3.26"

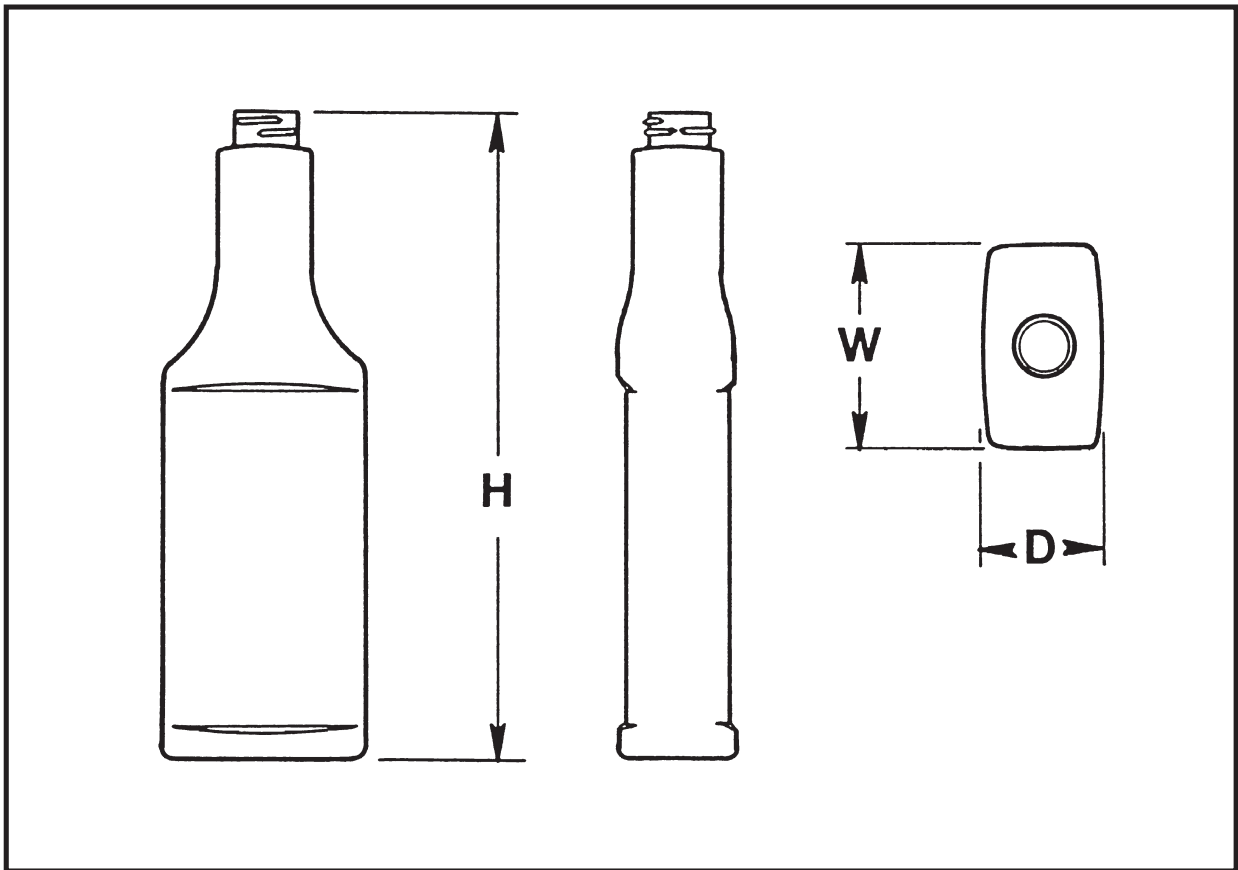
TALL LIBERTY OBLONGS**TALL LIBERTY OBLONGS**

CAPACITY	NECKS	MATERIAL	HEIGHT	WIDTH	DEPTH
6 oz	22-400	HDPE	6.98"	2.55"	1.46"
8 oz	22-400	HDPE	8.13"	2.55"	1.46"

Available with and without view striping.

LIBERTY OBLONGS

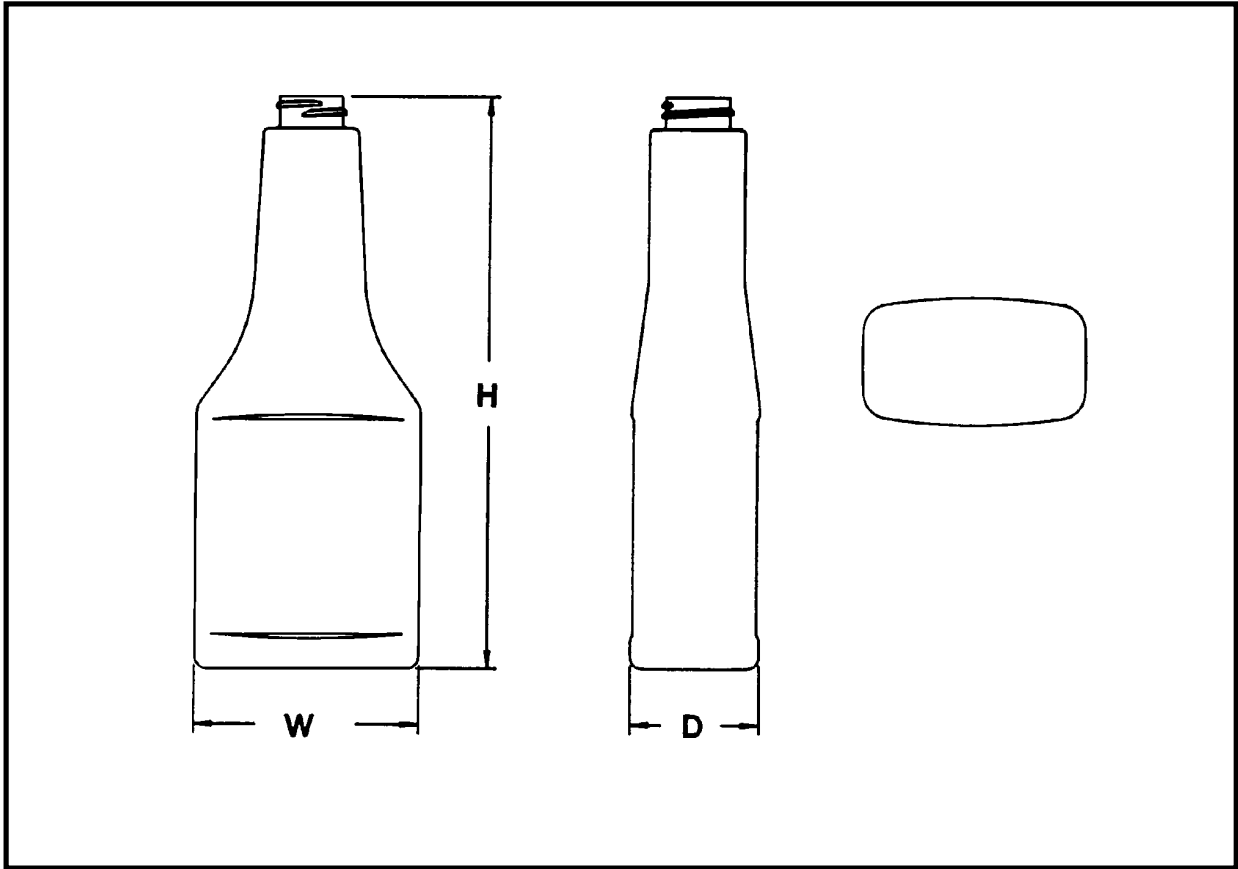

LIBERTY OBLONGS

CAPACITY	NECKS	MATERIAL	HEIGHT	WIDTH	DEPTH
8 oz	22-400 .414"	PVC	7.01"	2.74"	1.53"
8 oz	22-400 .467"	PVC	7.06"	2.74"	1.53"

LIBERTY OBLONGS

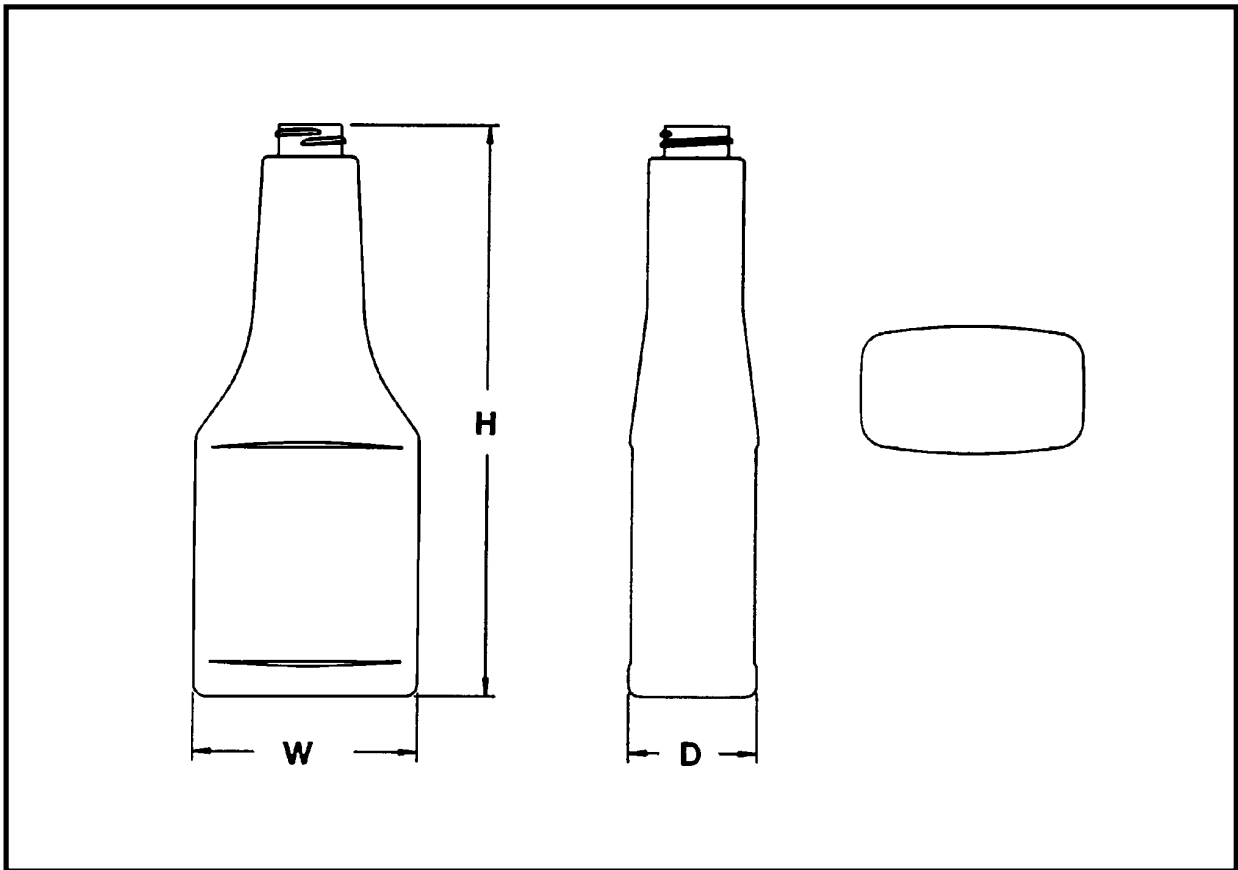

LIBERTY OBLONGS

CAPACITY	NECKS	MATERIAL	HEIGHT	WIDTH	DEPTH
12 oz	22-400 .485" H	PVC	7.97"	3.08"	1.74"
12 oz	22-400 .423" H	PVC	7.65"	3.08"	1.74"
12 oz	22-400 .457" H	PVC	7.91"	3.08"	1.74"
12 oz	24-410	PVC	8.127"	3.08"	1.74"
12 oz	33-400	PVC	7.99"	3.07"	1.67"
12 oz	22-400 .425" H	HDPE	7.90"	3.11"	1.77"
12 oz	22-400 .431" H	HDPE*	7.906"	3.11"	1.77"
12 oz	22-400 .460" H	HDPE	7.935"	3.11"	1.77"

* Also available with a Multi-Layer Barrier.

Pg. 130.00

LIBERTY OBLONGS

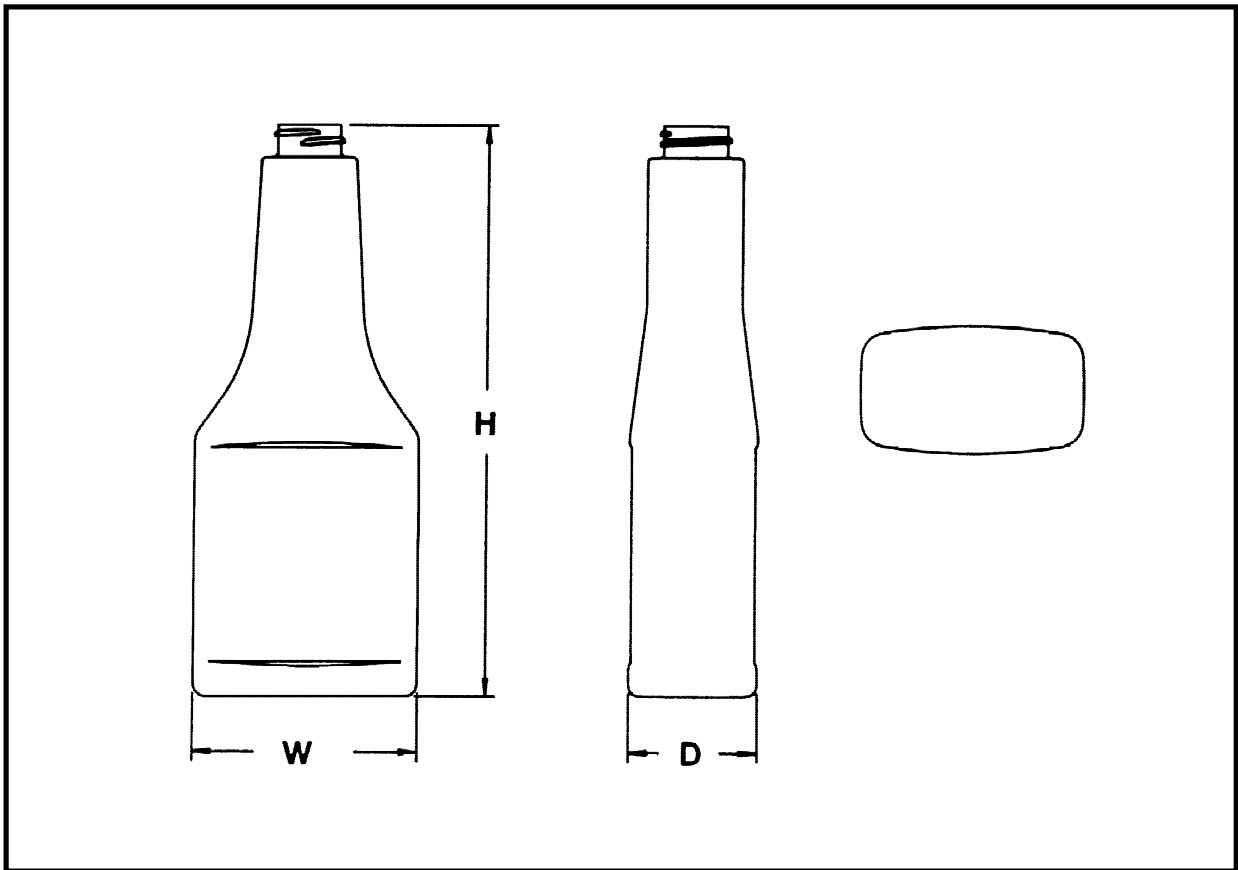

LIBERTY OBLONGS

CAPACITY	NECKS	MATERIAL	HEIGHT	WIDTH	DEPTH
13 oz	22-400 .460" H	HDPE or PP	8.211"	3.10"	1.76"
13 oz	28-400	PVC, HDPE or PP	8.141"	3.10"	1.76"
13 oz	33-400	HDPE or PP	8.141"	3.10"	1.76"

LIBERTY OBLONGS

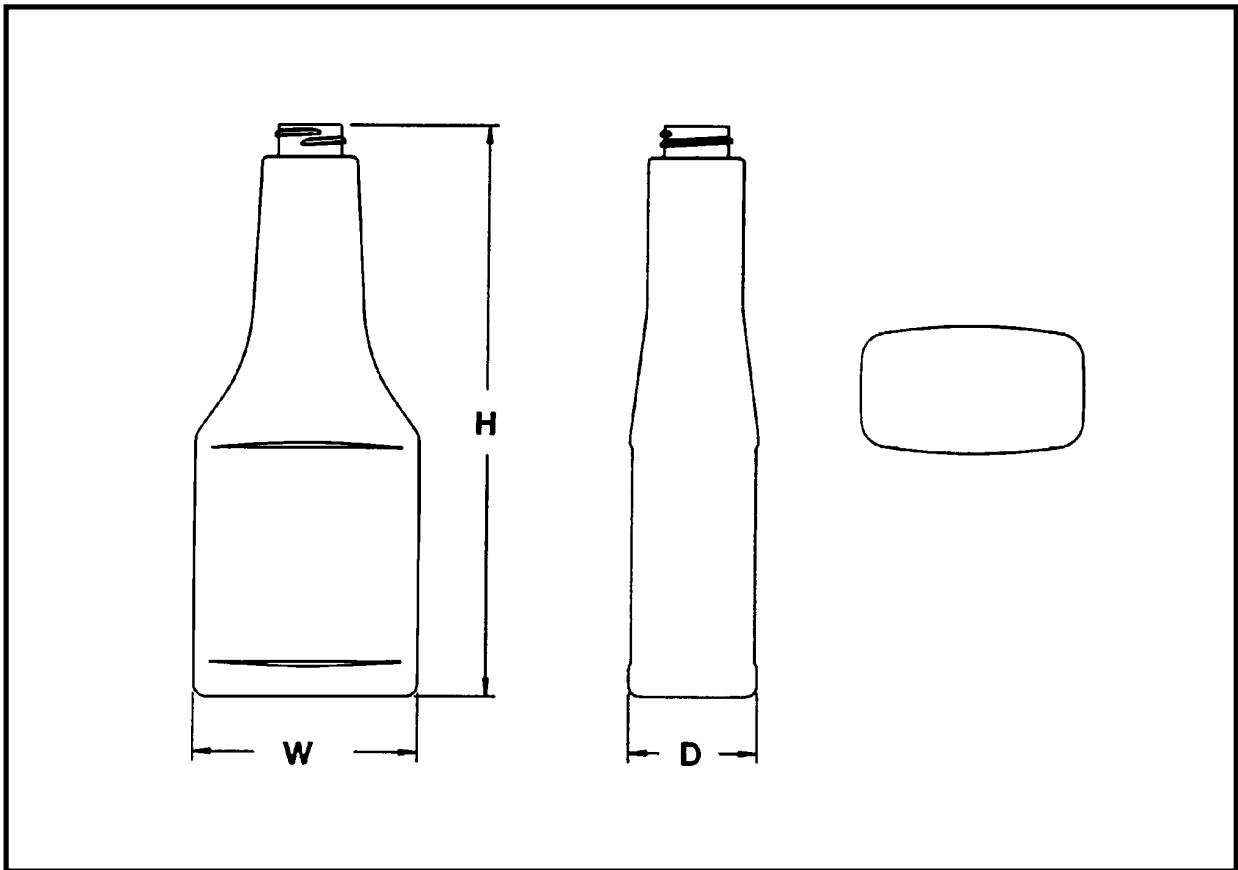

LIBERTY OBLONGS

CAPACITY	NECKS	MATERIAL	HEIGHT	WIDTH	DEPTH
14 oz	33-400	PVC	8.26"	3.07"	1.75"
15 oz	22-400	PVC	8.75"	3.06"	1.75"
15 oz	24-400	PVC	8.75"	3.06"	1.75"
15 oz	33-400	PVC	8.37"	3.40"	1.60"

LIBERTY OBLONGS

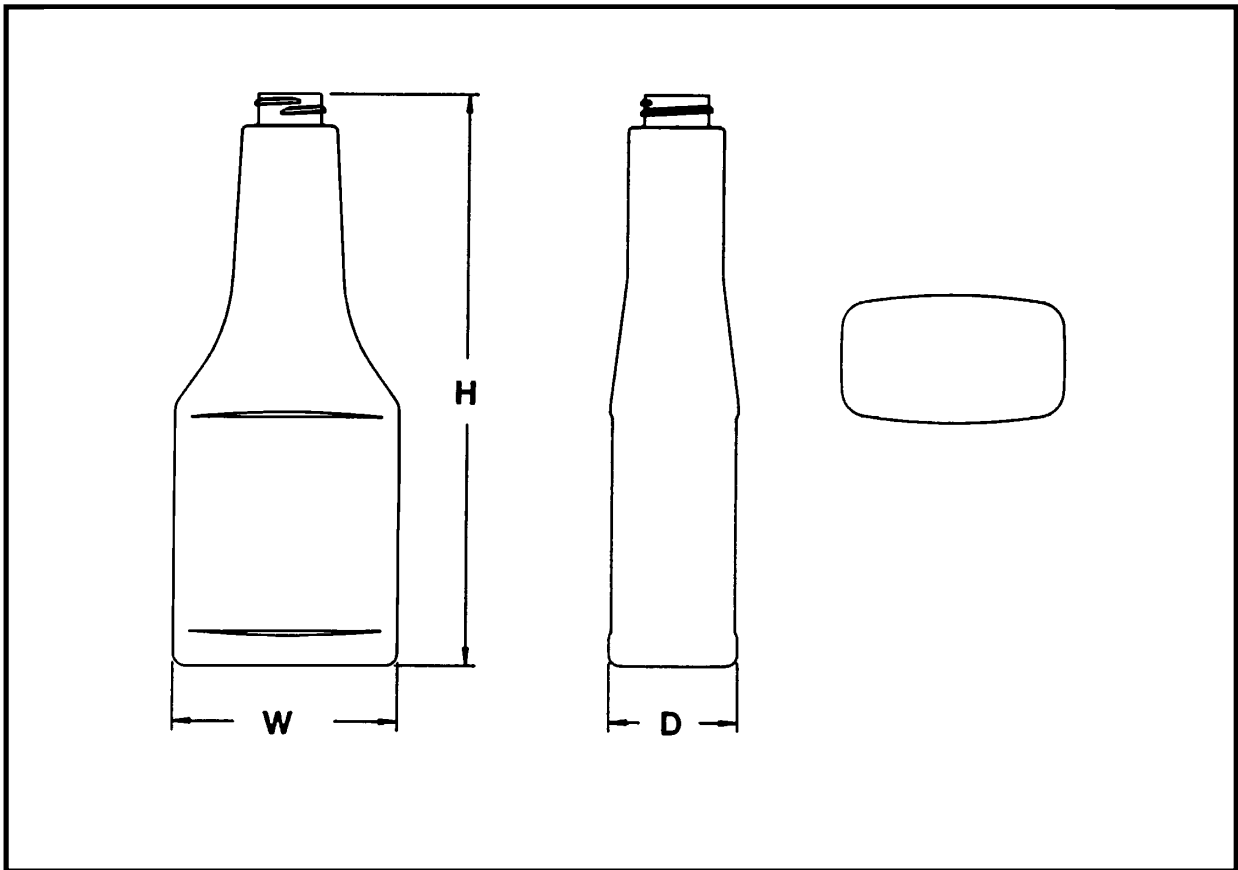

LIBERTY OBLONGS

CAPACITY	NECKS	MATERIAL	HEIGHT	WIDTH	DEPTH
16 oz	22-400 .404" H	PVC	8.96"	3.38"	1.63"
16 oz	22-400 .474" H	PVC	9.03"	3.38"	1.63"
16 oz	22-400 .5395" H	PVC	9.10"	3.38"	1.63"
16 oz	28-400	PVC	9.02"	3.38"	1.63"

LIBERTY OBLONGS

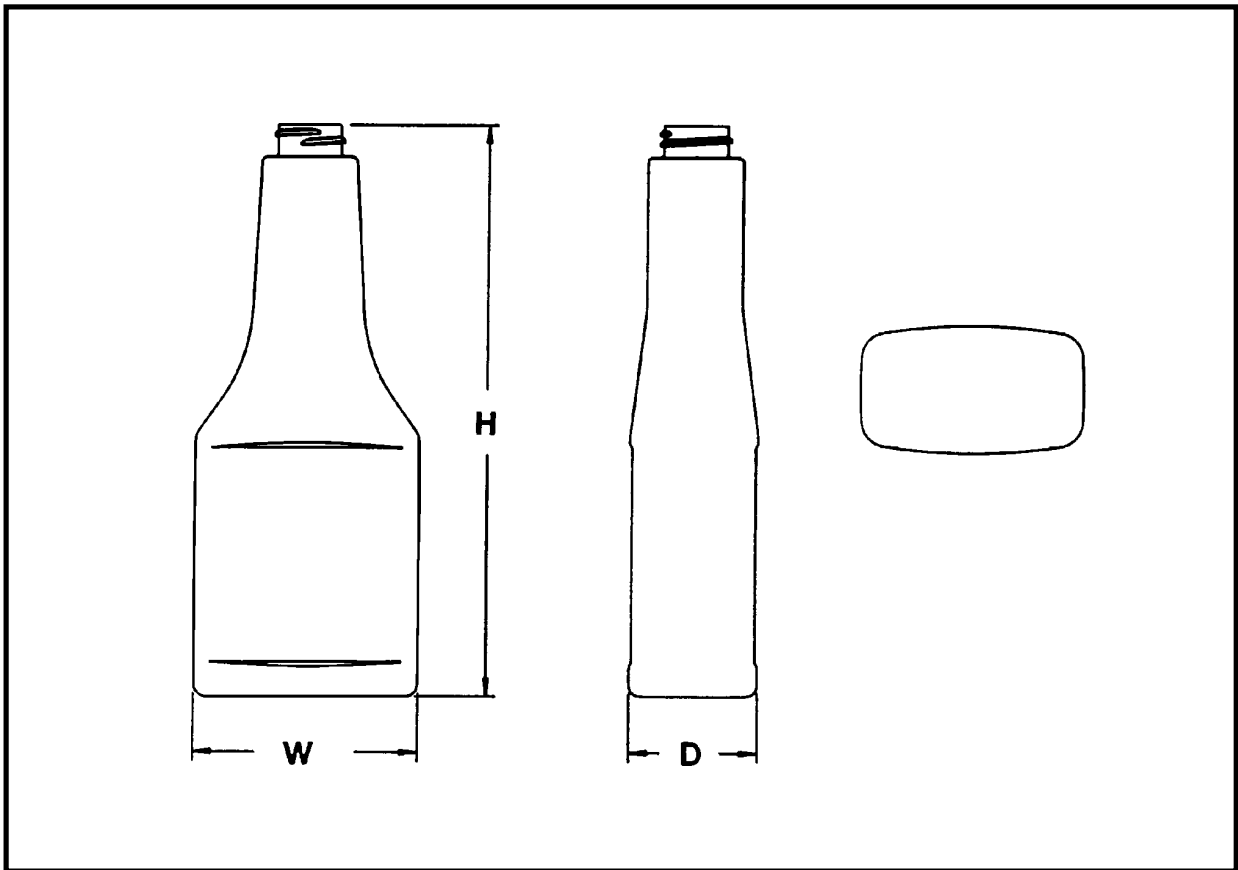

LIBERTY OBLONGS

CAPACITY	NECKS	MATERIAL	HEIGHT	WIDTH	DEPTH
17 oz	22-400 .404" H	PVC	9.40"	3.38"	1.63"
17 oz	22-400 .474" H	PVC	9.47"	3.38"	1.63"
17 oz	22-400 .5395" H	PVC	9.54"	3.38"	1.63"
17 oz	28-400	PVC	9.40"	3.38"	1.63"

FOOTED LIBERTY OBLONGS

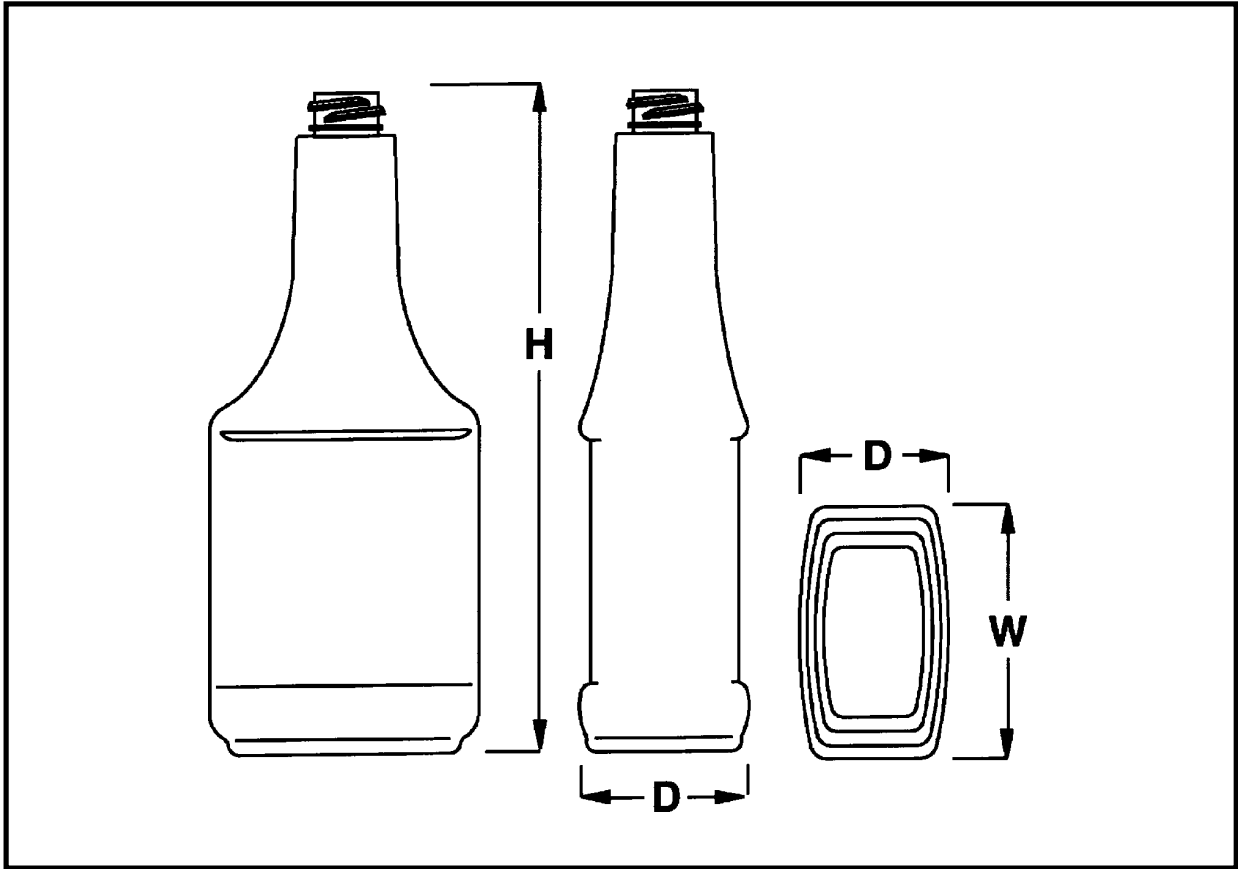

FOOTED LIBERTY OBLONGS

CAPACITY	NECKS	MATERIAL	HEIGHT	WIDTH	DEPTH
12 oz	22-400	PVC	7.94"	3.30"	1.99"
12 oz	22-400	Mono or Tri-Layer HDPE	7.97"	3.30"	1.94"
12 oz	28mm Drop-Lok	Mono or Tri-Layer HDPE	8.18"	3.30"	1.94"

STEADY GRIP^(R) OFFSET NECK OBLONG

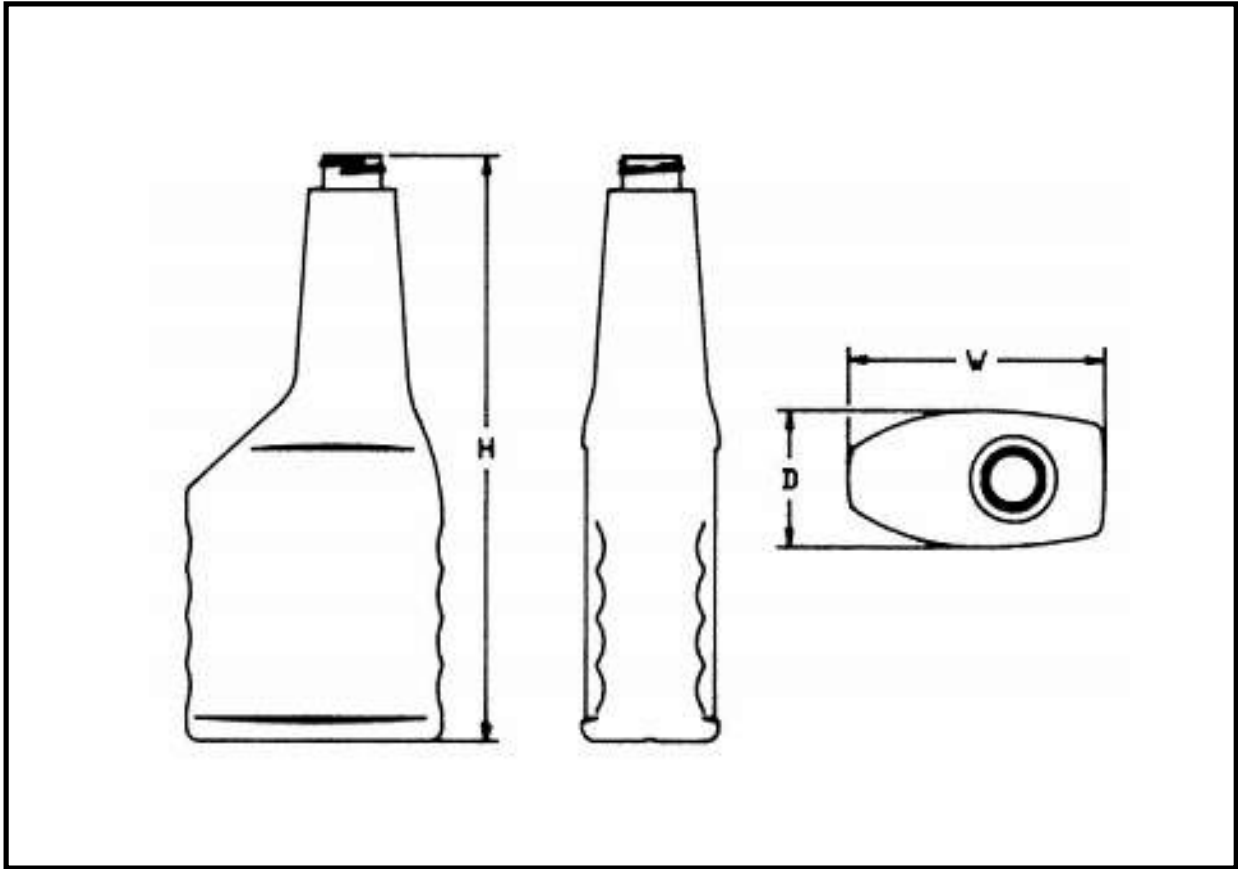

STEADY GRIP^(R) OFFSET NECK OBLONG

CAPACITY	NECKS	MATERIAL	HEIGHT	WIDTH	DEPTH
12 oz*	22-400	PVC	7.86"	3.44"	1.836"
18 oz**	22-400	PVC	9.363"	3.725"	1.836"

*U.S. Patent No. Des. 430,032

**U.S. Patent No. Des. D576,884 S

STEADY GRIP^(R) OFFSET NECK OBLONG

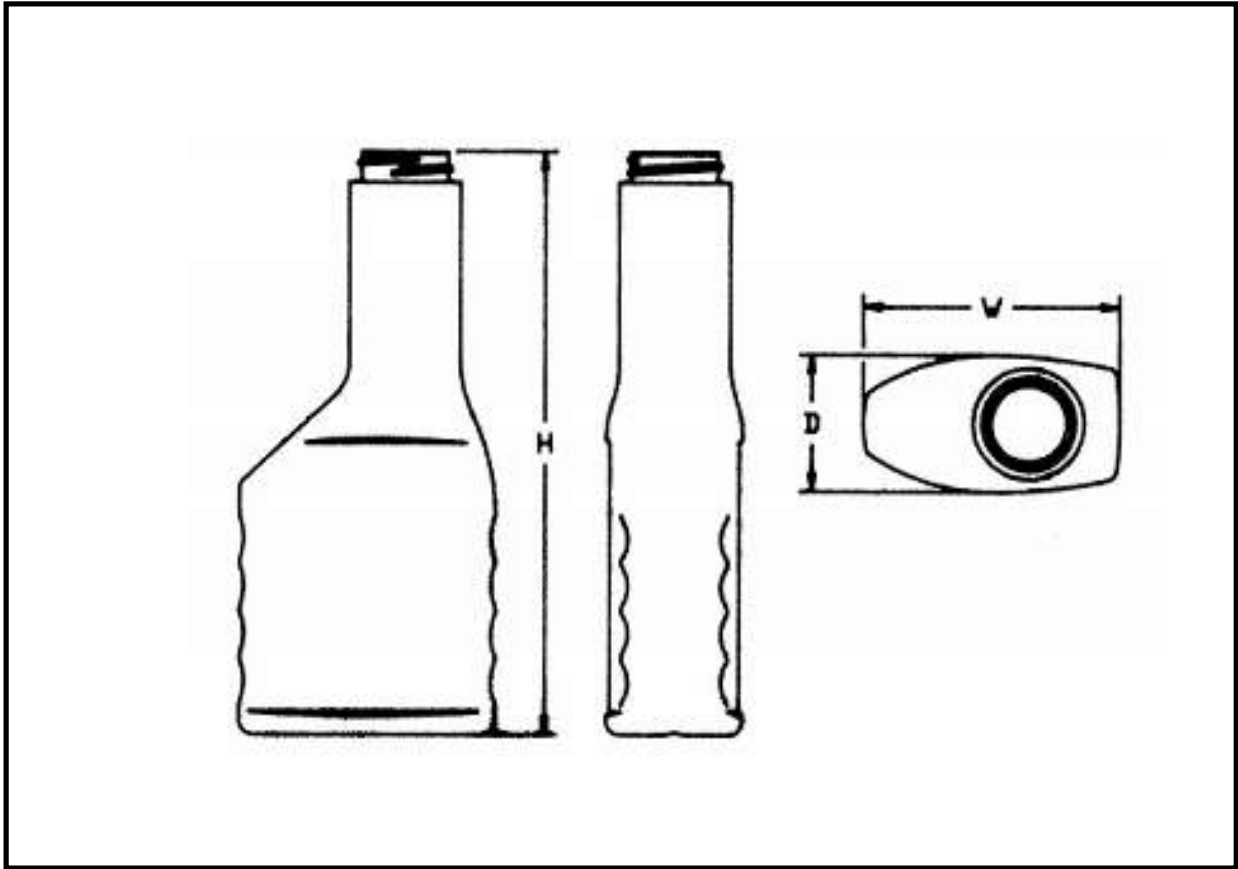

STEADY GRIP^(R) OFFSET NECK OBLONG

CAPACITY	NECKS	MATERIAL	HEIGHT	WIDTH	DEPTH
12 oz	33-400	PVC	7.813"	3.44"	1.836"
12 oz	33-400*	PVC	7.893"	3.44"	1.836"

U.S. Patent No. Des. 430,032
 * .480" "H" dimension

CENTER NECK OBLONG

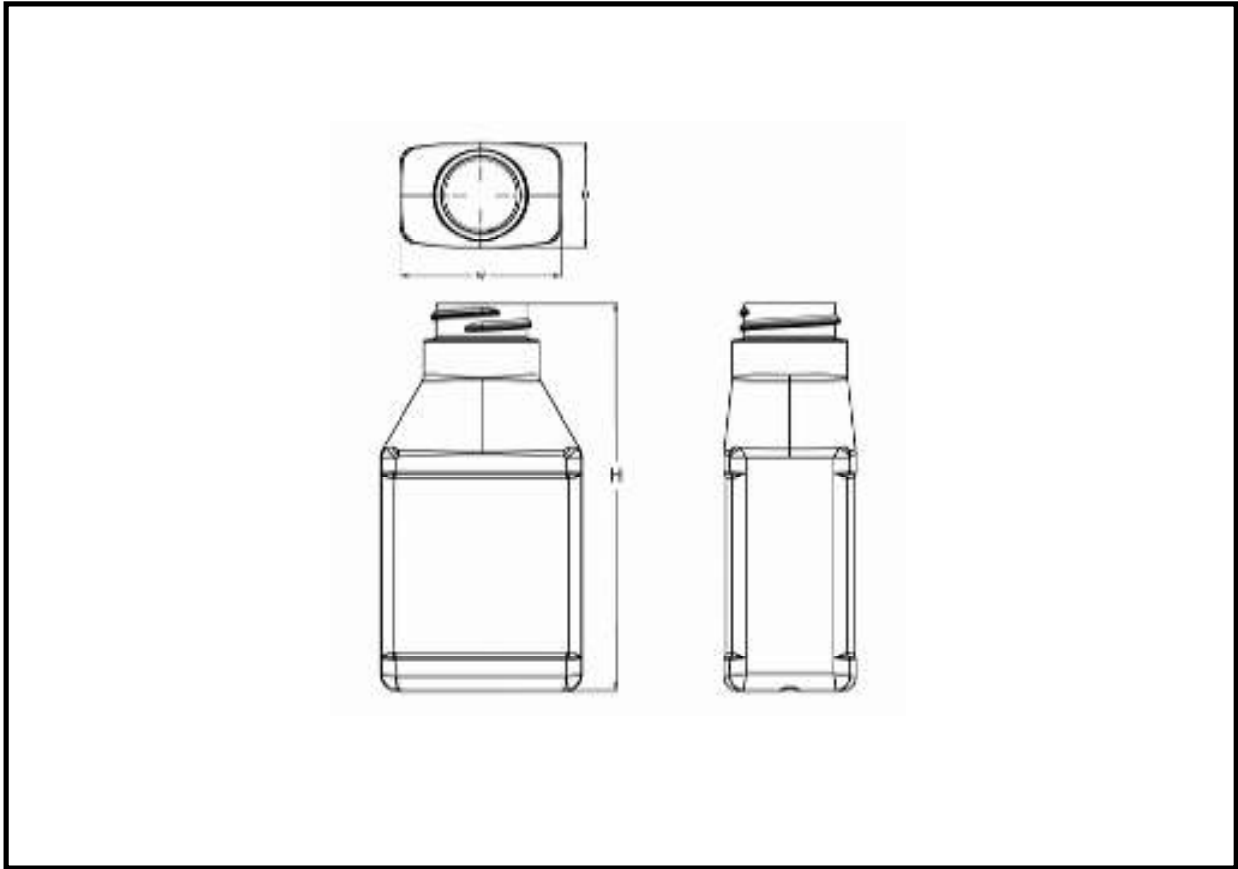

CENTER NECK OBLONG

CAPACITY	NECKS	MATERIAL	HEIGHT	WIDTH	DEPTH
4 oz	28-400	HDPE	4.200"	2.187"	1.432"

CENTER NECK OBLONG WITH GRADUATIONS

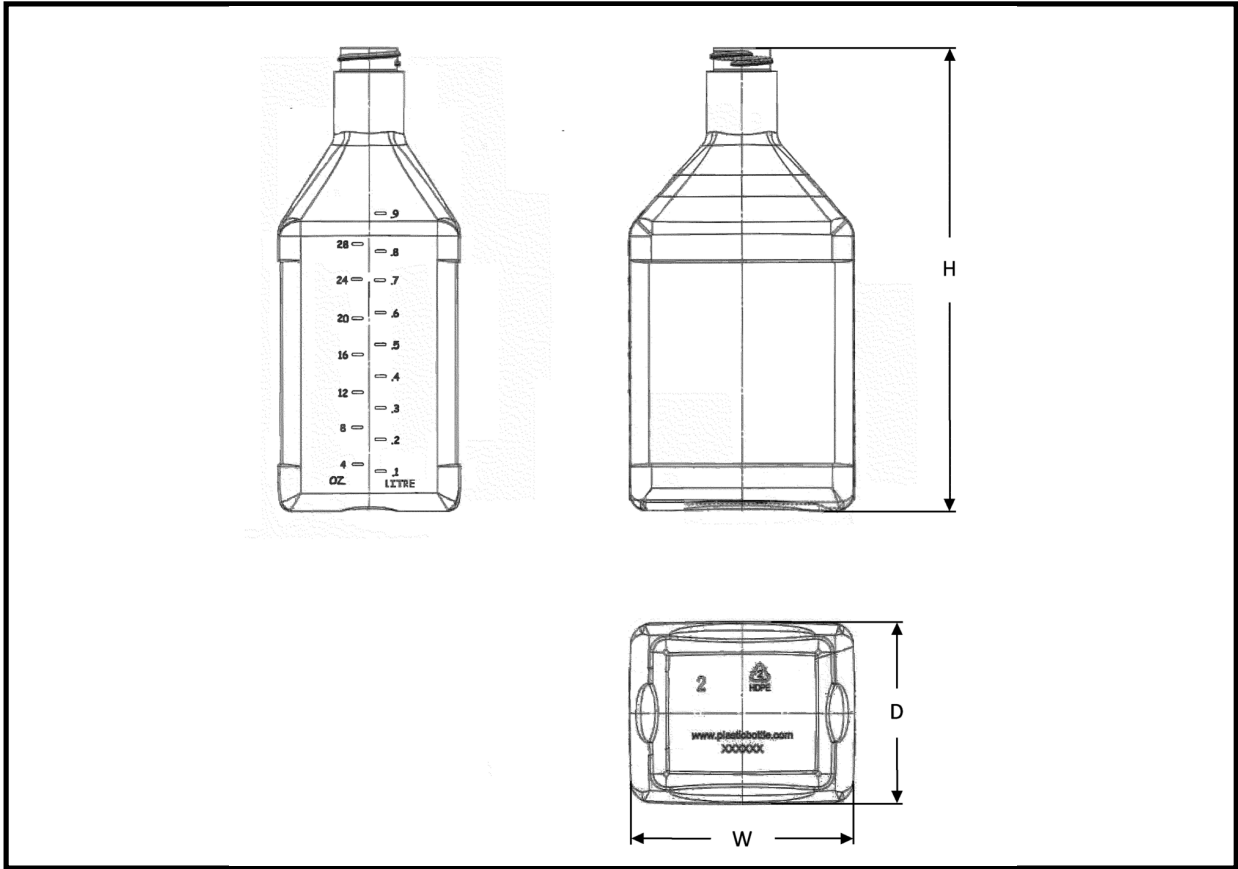

CENTER NECK OBLONG WITH GRADUATIONS

CAPACITY	NECKS	MATERIAL	HEIGHT	WIDTH	DEPTH
32 oz / 1 Liter	28-400	HDPE	8.00"	3.875"	3.156"

Available with or without view stripe

OFFSET NECK OBLONGS

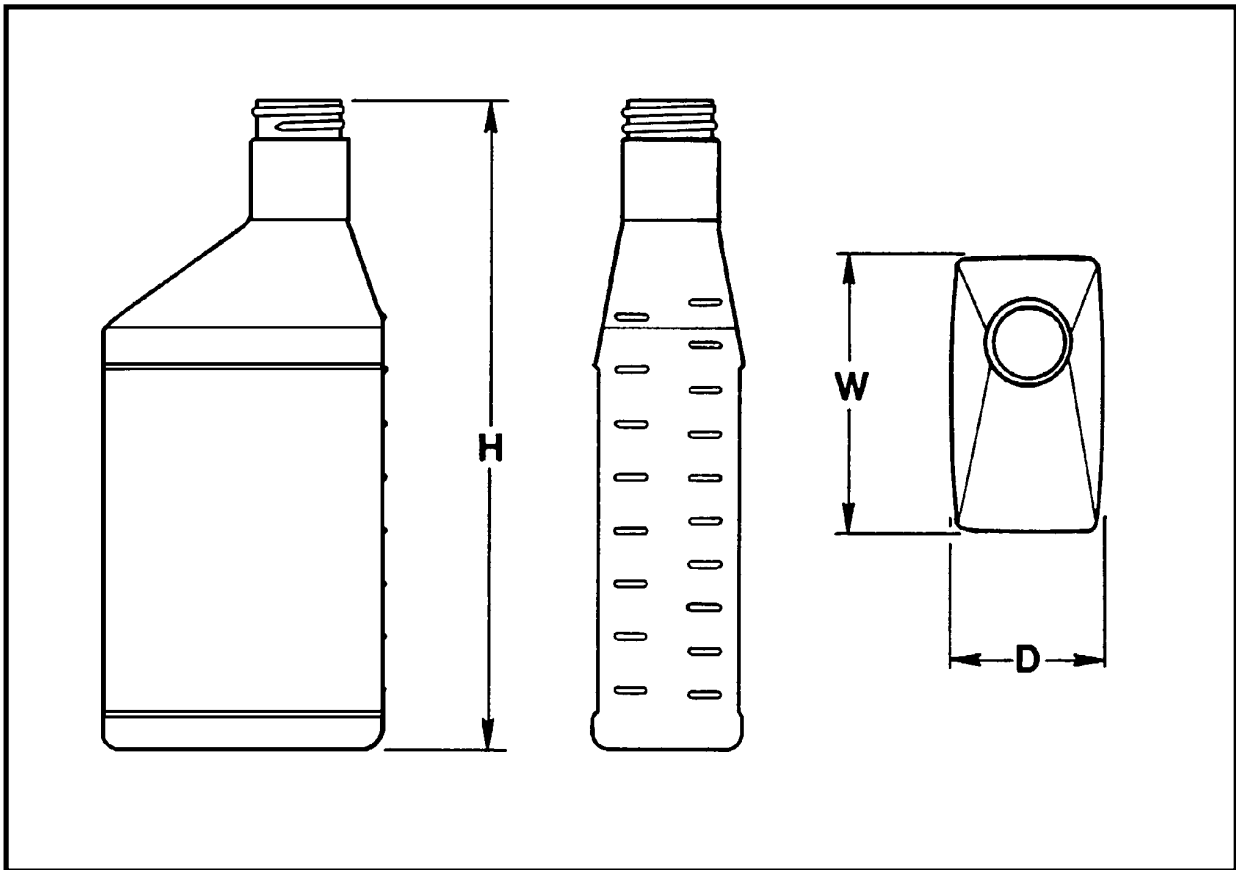

OFFSET NECK OBLONGS

CAPACITY	NECKS	MATERIAL	HEIGHT	WIDTH	DEPTH
8 oz / 250 ml	28-400 .440" H	HDPE	6.497"	2.756"	1.596"
8 oz / 250 ml	28mm Drop-Lok	HDPE	6.787"	2.756"	1.596"
16 oz / 500 ml	28-400	HDPE	7.69"	3.31"	1.94"
16 oz / 500 ml	28-400 .430" H	HDPE	7.705"	3.31"	1.94"
16 oz / 500 ml	28-400 .437" H	HDPE	7.71"	3.31"	1.94"
16 oz / 500 ml	28-410	HDPE	8.04"	3.31"	1.94"
16 oz / 500 ml	28mm Drop-Lok	HDPE	8.03"	3.31"	1.94"

Engraved with ml and oz graduations
 Available with and without view stripe.

OFFSET NECK OBLONGS

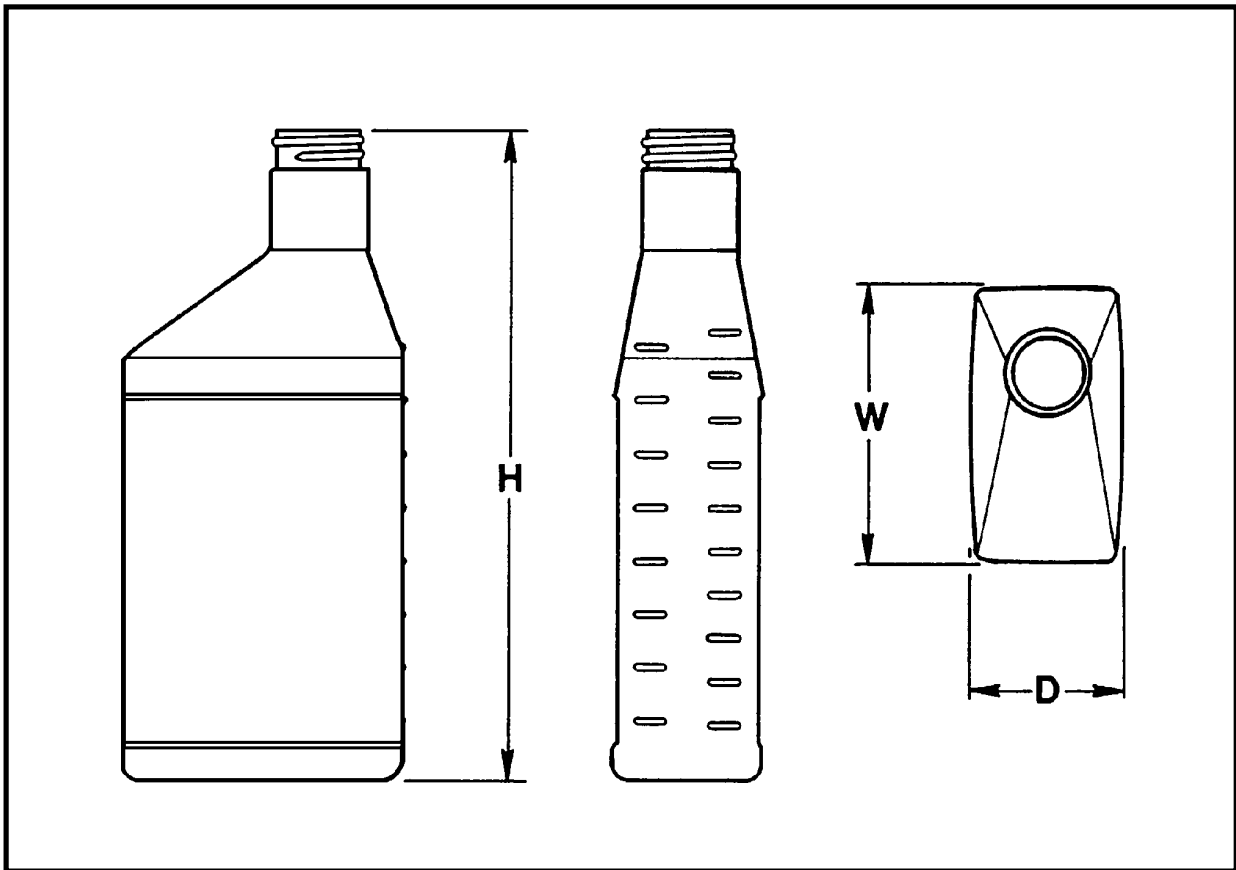

OFFSET NECK OBLONGS

CAPACITY	NECKS	MATERIAL	HEIGHT	WIDTH	DEPTH
16 oz / 500 ml	28mm Uni-Lok*	HDPE	8.03"	3.31"	1.94"
16 oz / 500 ml	33-400	HDPE	7.70"	3.31"	1.94"
16 oz / 500 ml	33-400 .510" H	HDPE	7.83"	3.31"	1.94"
20 oz	28-400	HDPE	8.97"	3.31"	1.94"
32 oz / 1 Liter	28-400 .437" H	HDPE	9.501"	4.252"	2.525"

Engraved with ml and oz graduations
 Available with and without view stripe.
 *Fits Alcoa's Uni-Lok

DOVER OBLONGS

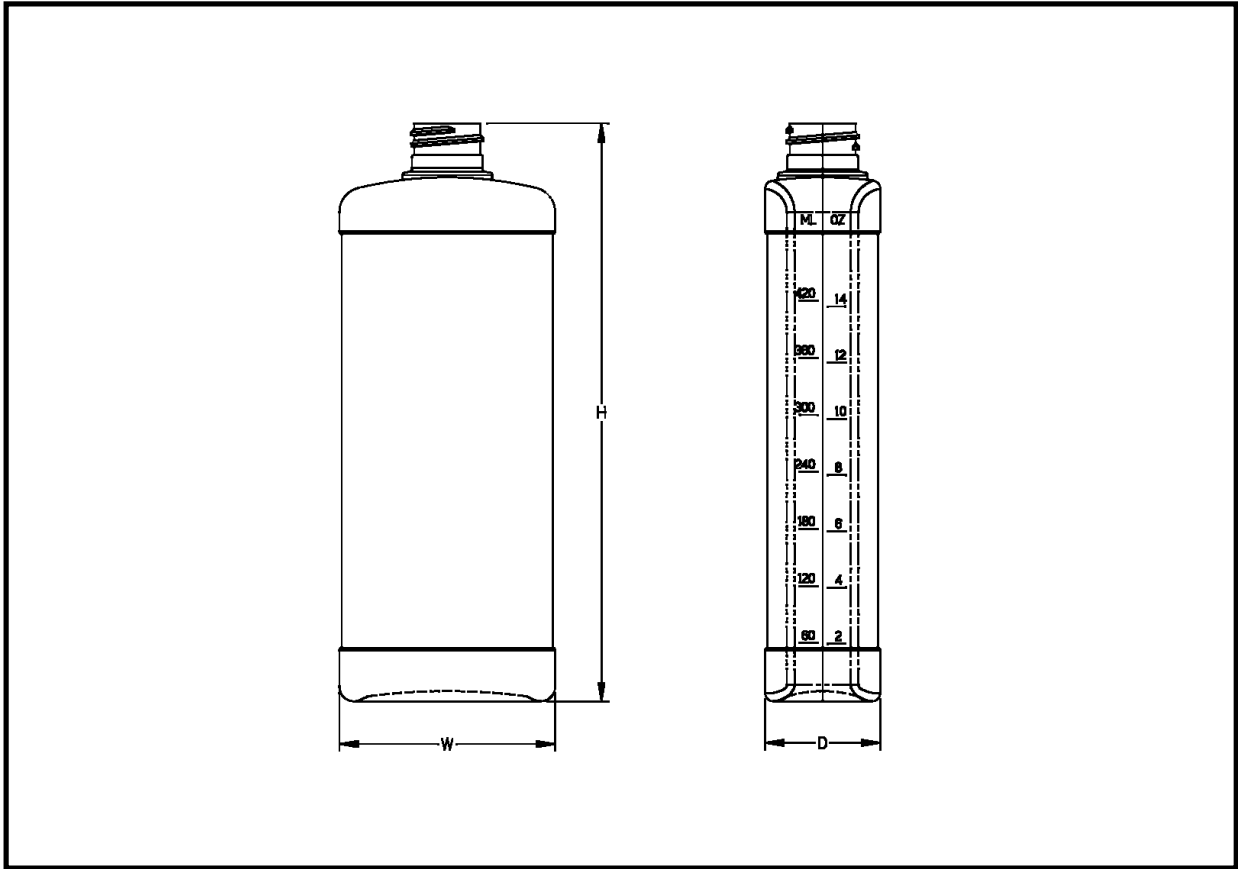

DOVER OBLONGS

CAPACITY	NECKS	MATERIAL	HEIGHT	WIDTH	DEPTH
16 oz	28-410	HDPE	8.736"	3.218"	1.718"
16 oz	30mm Foamer	HDPE	8.406"	3.218"	1.718"

Available with or without view stripe

OFFSET NECK OBLONGS

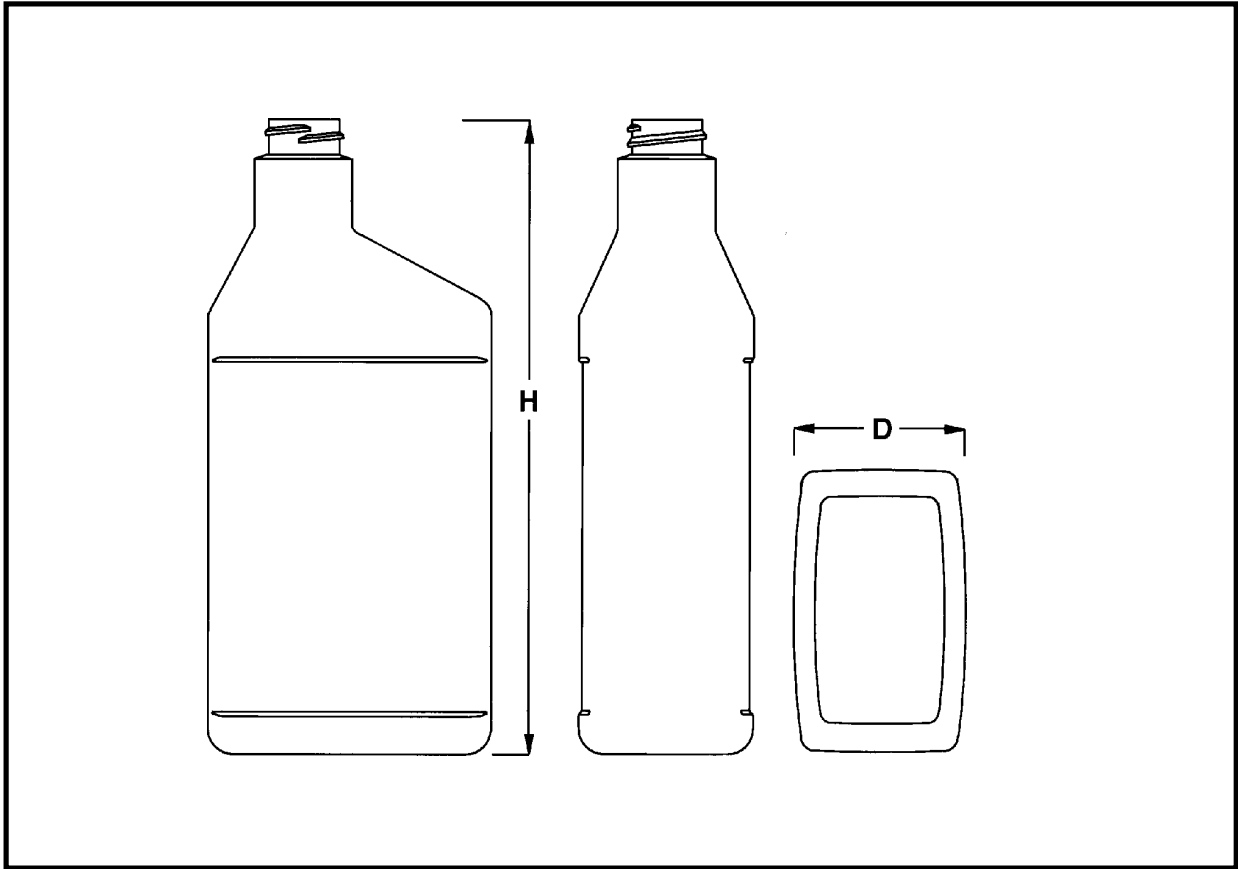

OFFSET NECK OBLONGS

CAPACITY	NECKS	MATERIAL	HEIGHT	WIDTH	DEPTH
32 oz / 1 liter	28-400	PVC	8.98"	4.06"	2.59"
32 oz / 1 liter	33-400	PVC	8.98"	4.06"	2.59"
32 oz / 1 liter	33-400 .515"H	PVC	9.092"	4.06"	2.59"

OCTANE OBLONG

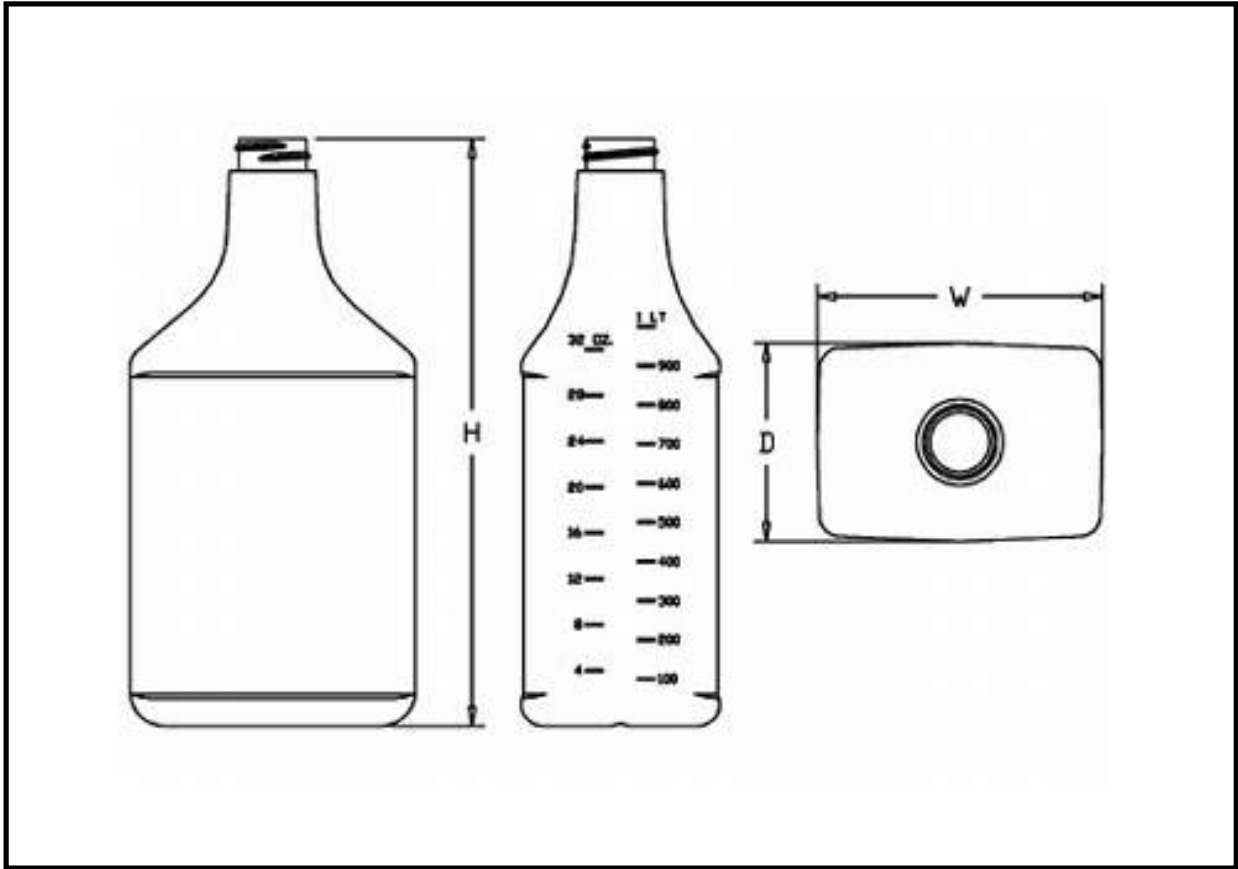

OCTANE OBLONG

CAPACITY	NECKS	MATERIAL	HEIGHT	WIDTH	DEPTH
32 oz / 1 Liter	28-400	PVC	8.505"	4.135"	2.75"

Engraved with ml and oz graduations

CENTER NECK OBLONGS

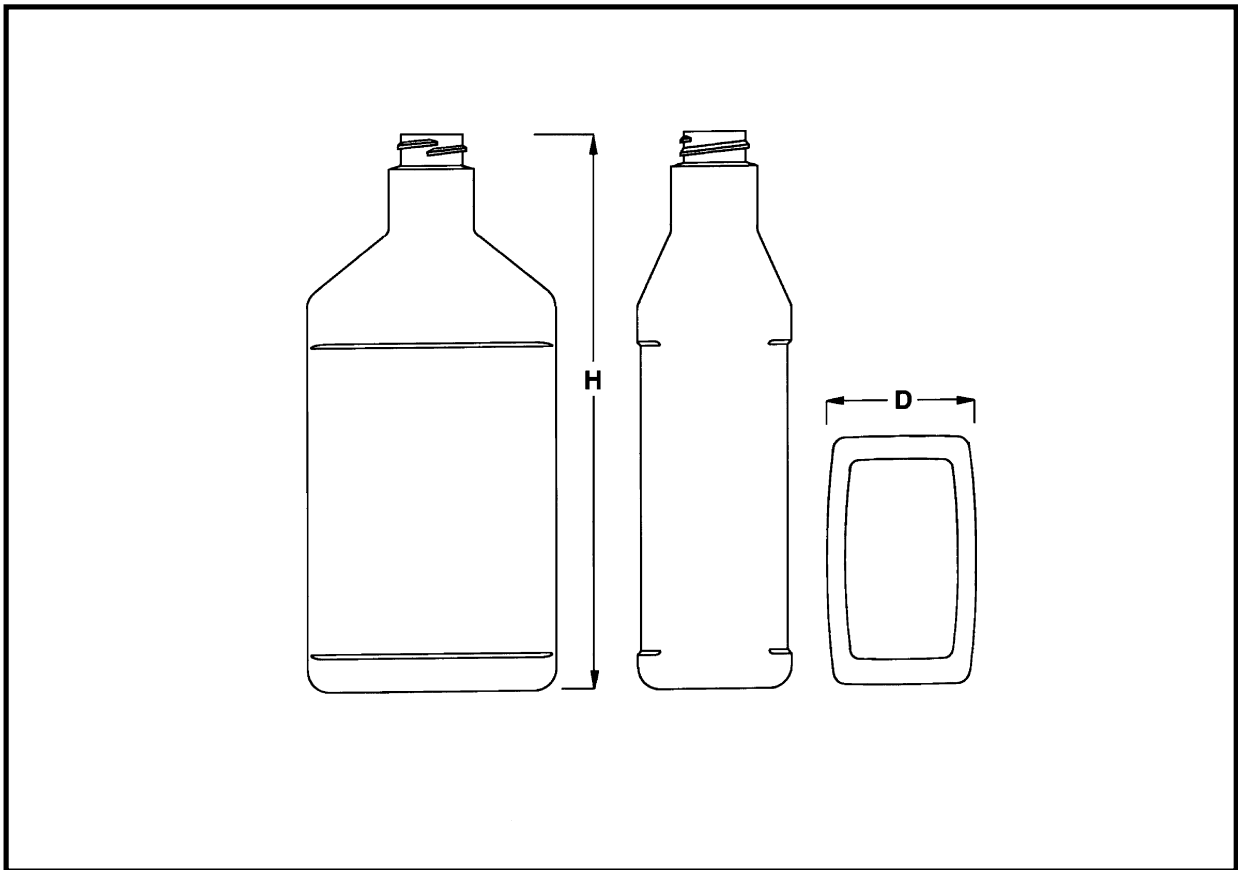

CENTER NECK OBLONGS

CAPACITY	NECKS	MATERIAL	HEIGHT	WIDTH	DEPTH
32 oz/1 liter	28-400	PVC	8.98"	4.06"	2.59"
32 oz/1 liter	33-400	PVC	8.98"	4.06"	2.59"
32 oz/1 liter	33-400 .515" H	PVC	9.092"	4.06"	2.59"

DAYTONA OBLONGS

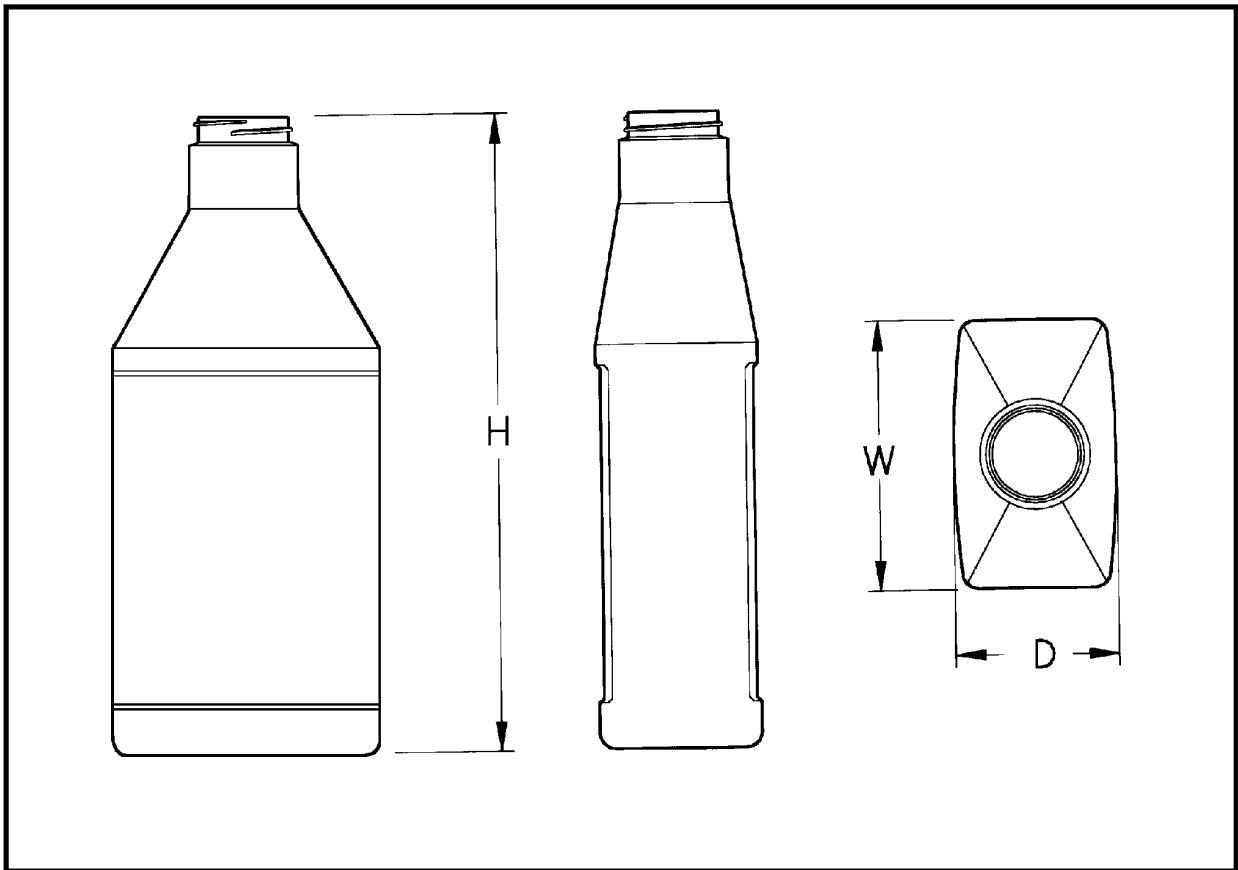

DAYTONA OBLONGS

CAPACITY	NECKS	MATERIAL	HEIGHT	WIDTH	DEPTH
16 oz / 500ml	33-400	HDPE	7.90"	3.38"	2.00"
16 oz / 500ml	33-400 .582" H*	HDPE	8.09"	3.38"	2.00"
24 oz / 750ml	38-400	HDPE	8.90"	3.87"	2.30"
24 oz / 750ml	38-400 .510" H	HDPE	9.02"	3.87"	2.30"
32 oz / 1 Liter	38-400	HDPE	9.50"	4.00"	2.437"

Available with and without view striping.

*This neck is within SPI specifications but was made specifically for a Van Blarcom Saf Cap III - A, drawing no. 2063.

ANDOVER OBLONGS

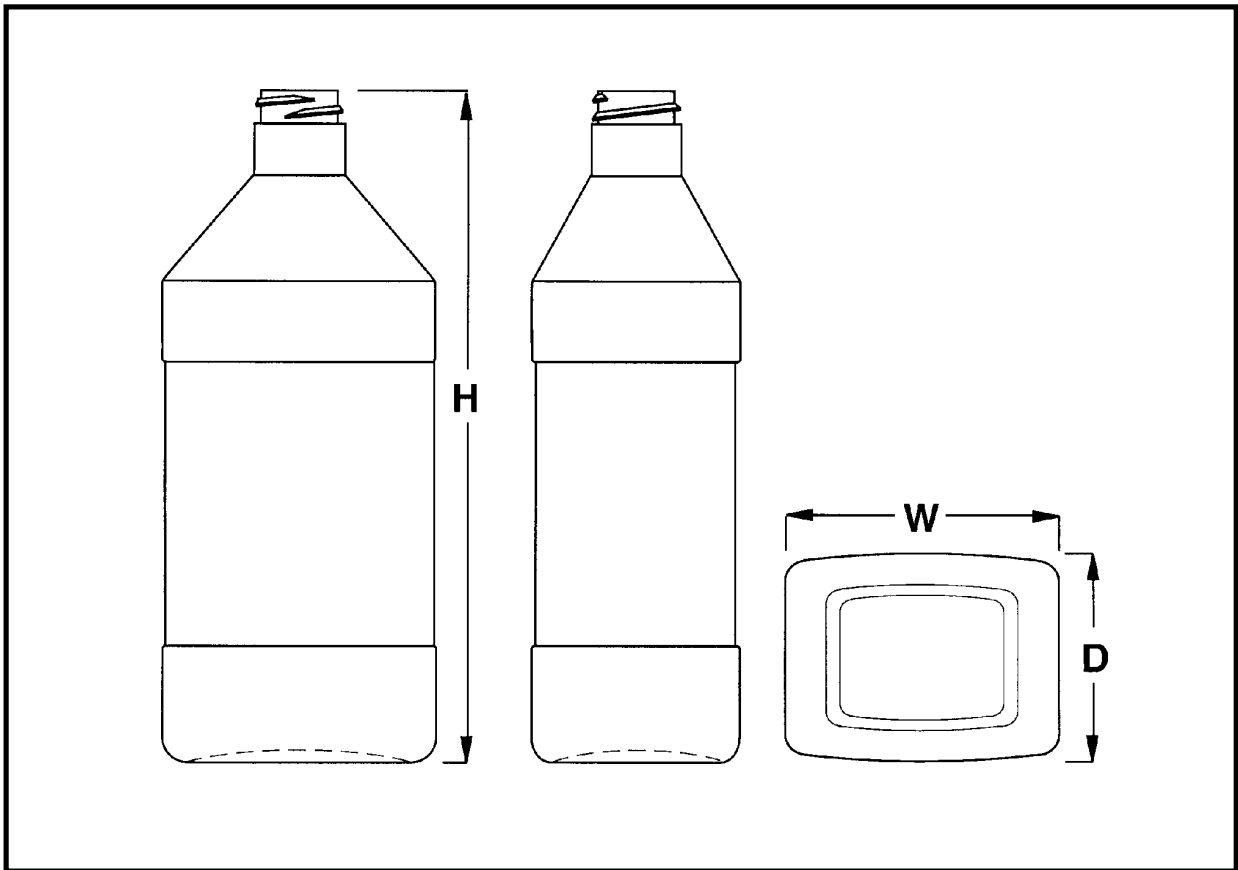

ANDOVER OBLONGS

CAPACITY	NECKS	MATERIAL	HEIGHT	WIDTH	DEPTH
32 oz	28-400	HDPE	8.71"	3.48"	2.68"
32 oz	28-400 .455H	HDPE	8.765"	3.48"	2.68"
1 Liter	28-400	HDPE	9.11"	3.48"	2.68"
1 Liter	28-400 .455H	HDPE	9.165"	3.48"	2.68"

Available with and without customized inserts.
 Available with and without view striping.

EXETER OBLONG

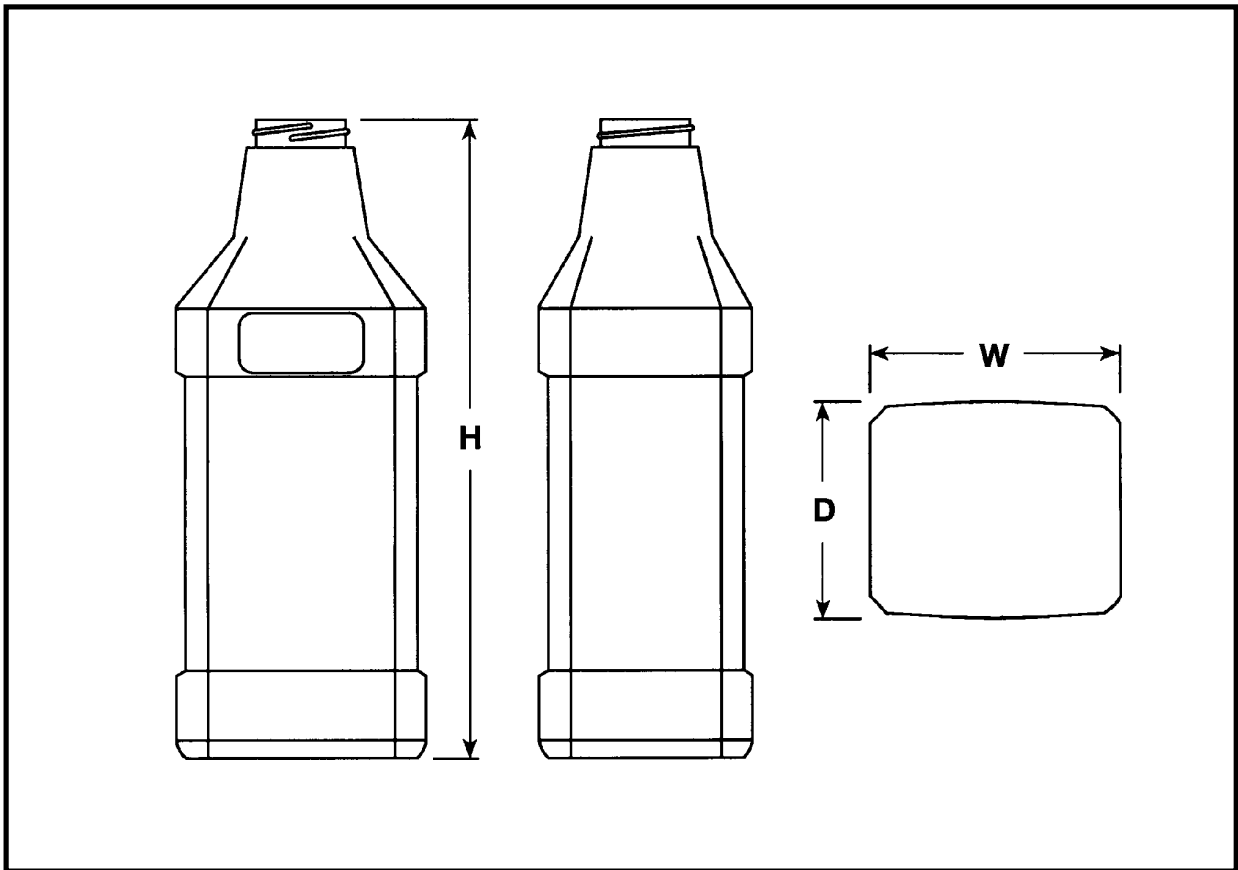

EXETER OBLONG

CAPACITY	NECKS	MATERIAL	HEIGHT	WIDTH	DEPTH
32 oz / 1 Liter	38-400	HDPE	8.88"	3.67"	3.30"
32 oz / 1 Liter	38-400 .520" H	HDPE	8.98"	3.67"	3.30"

Available with and without customized inserts.
 Available with and without view striping.

TILT-NECK OBLONGS

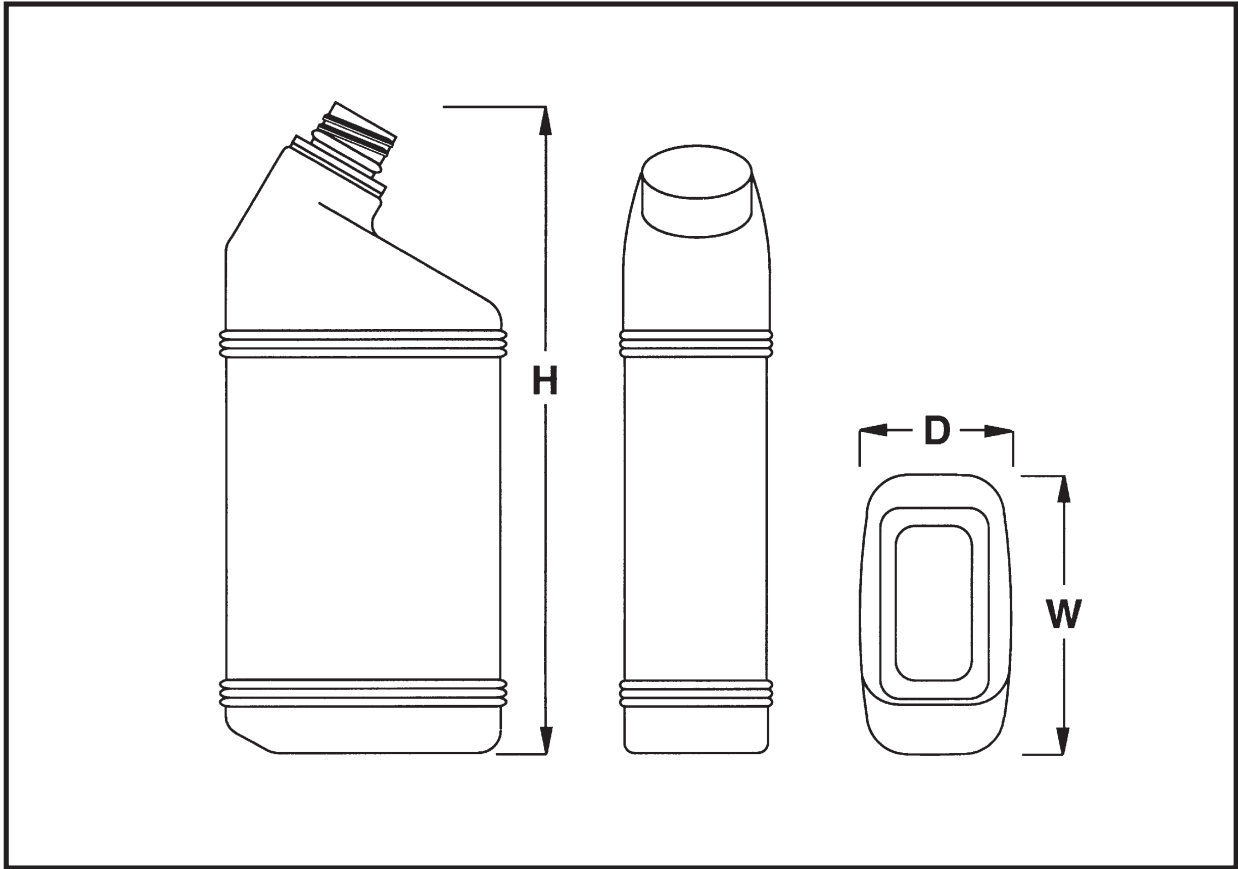

TILT-NECK OBLONGS

CAPACITY	NECKS	MATERIAL	HEIGHT	WIDTH	DEPTH
24 oz	28mm	HDPE	9.84"	4.25"	2.24"

Design Patent #29/043,488.

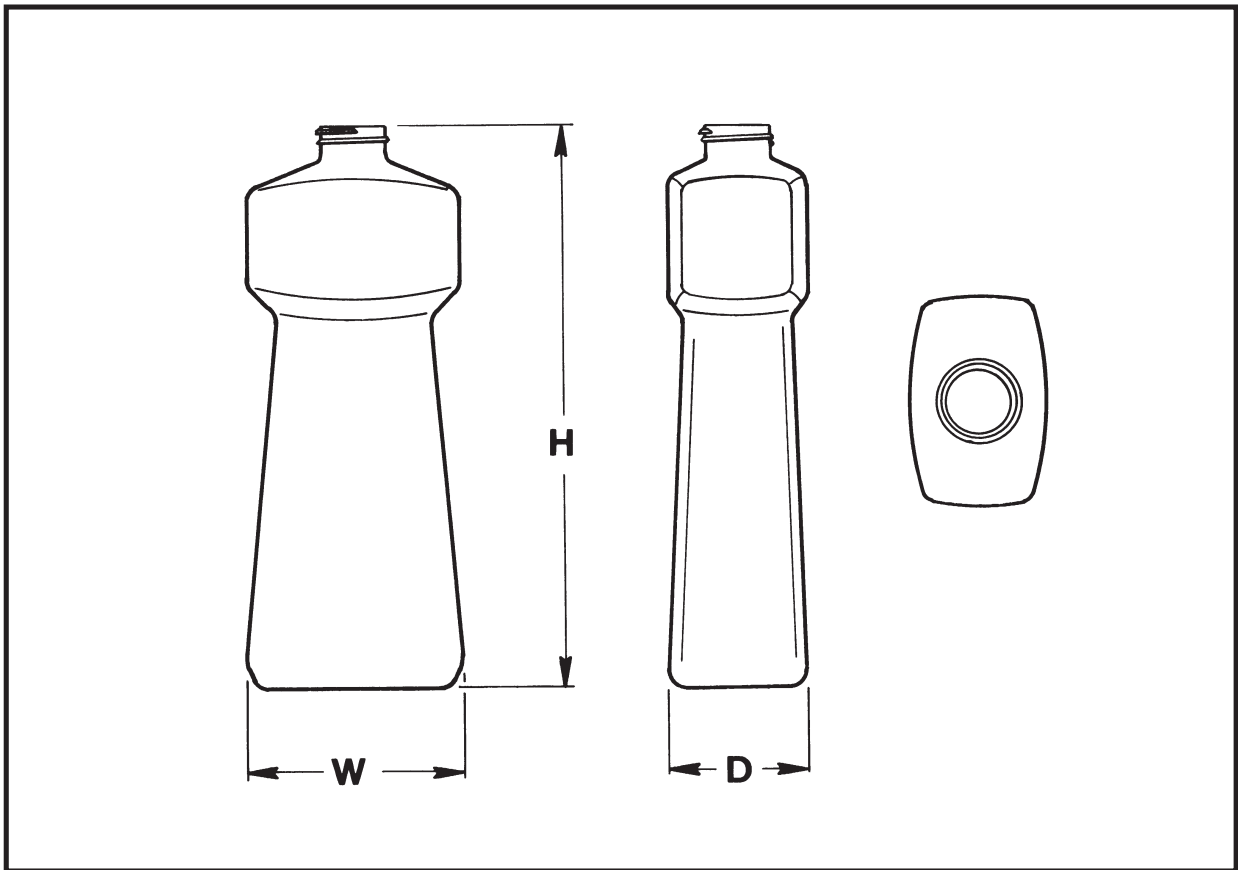
BARRINGTON OBLONG**BARRINGTON OBLONG**

CAPACITY	NECKS	MATERIAL	HEIGHT	WIDTH	DEPTH
28 oz	33-400	HDPE	9.77"	3.71"	2.30"

CONCAVE/CONVEX FLASK

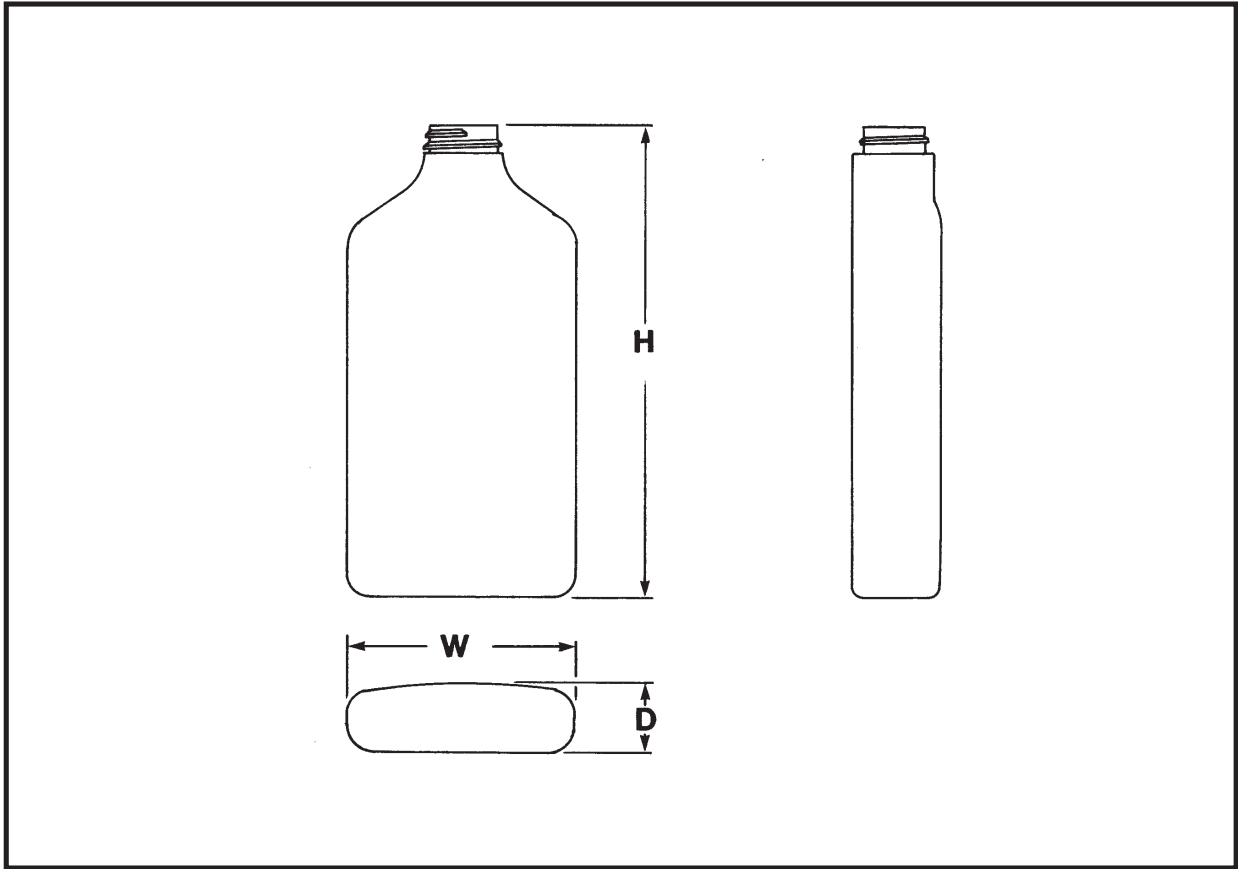

CONCAVE/CONVEX FLASK

CAPACITY	NECKS	MATERIAL	HEIGHT	WIDTH	DEPTH
8 oz	28-400	HDPE	5.80"	3.25"	1.24"

GALAXY OBLONG

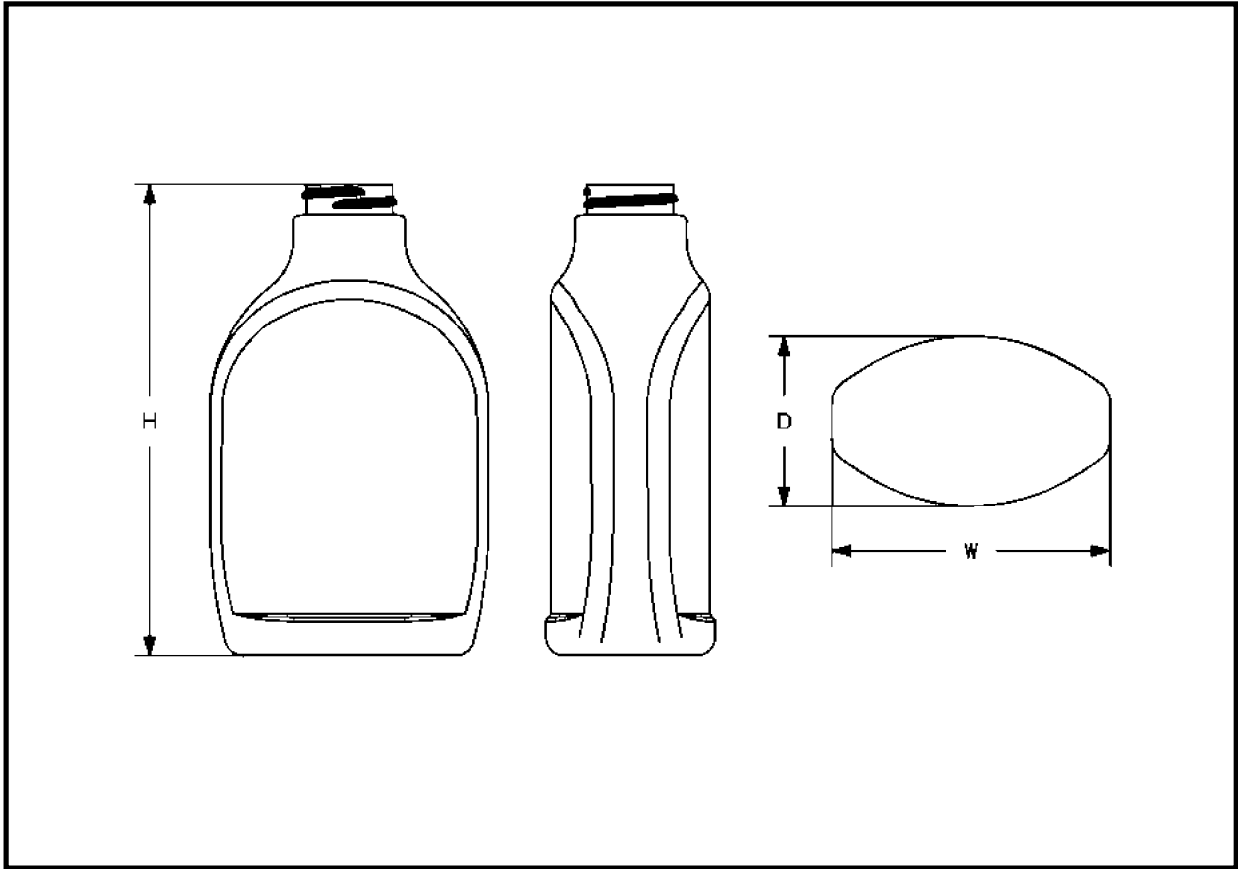

GALAXY OBLONG

CAPACITY	NECKS	MATERIAL	HEIGHT	WIDTH	DEPTH
16 oz	33-400	HDPE	6.312"	3.725"	2.265"

PHARMA OBLONG

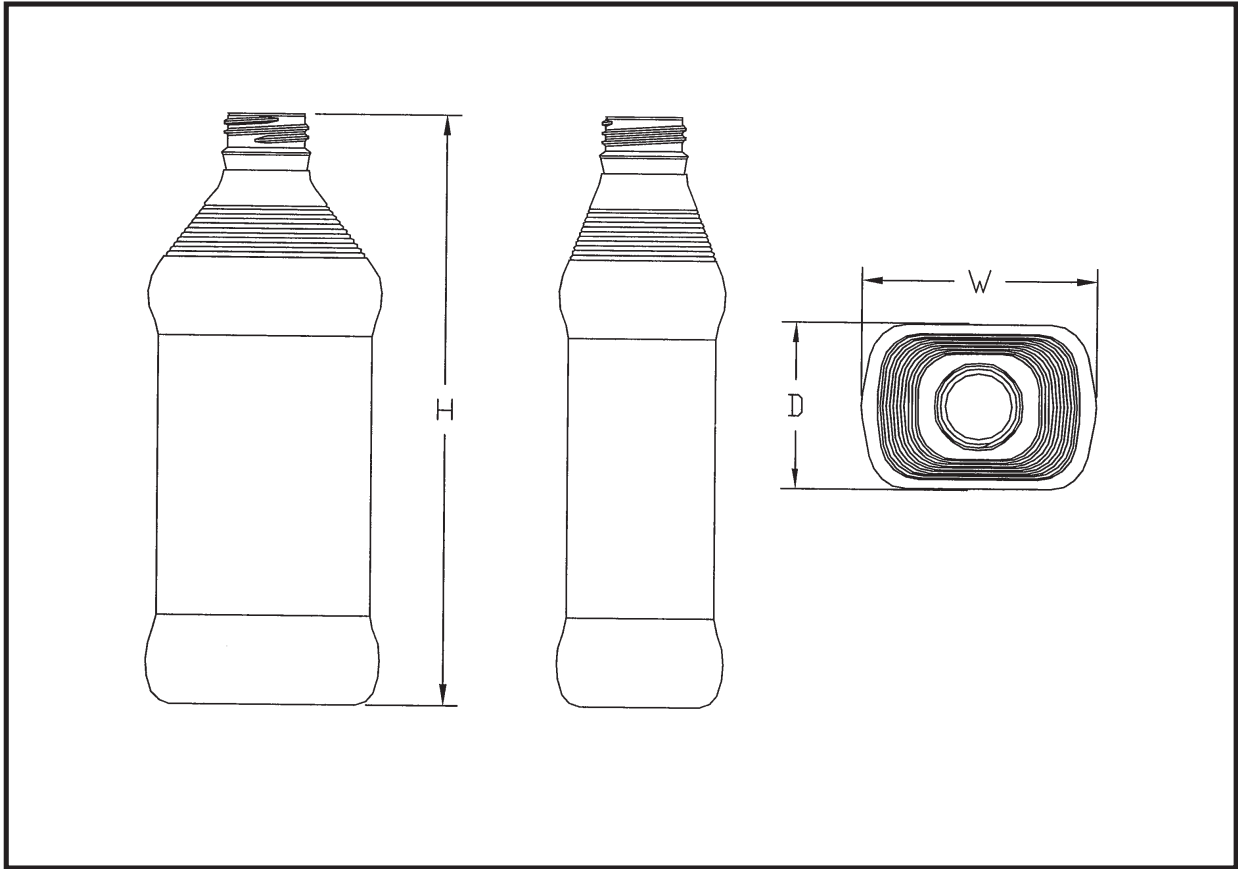

PHARMA OBLONG

CAPACITY	NECKS	MATERIAL	HEIGHT	WIDTH	DEPTH
16 oz	28mm Drop-Lok	HDPE	7.595"	3.00"	2.15"

PINCH WAIST OBLONG

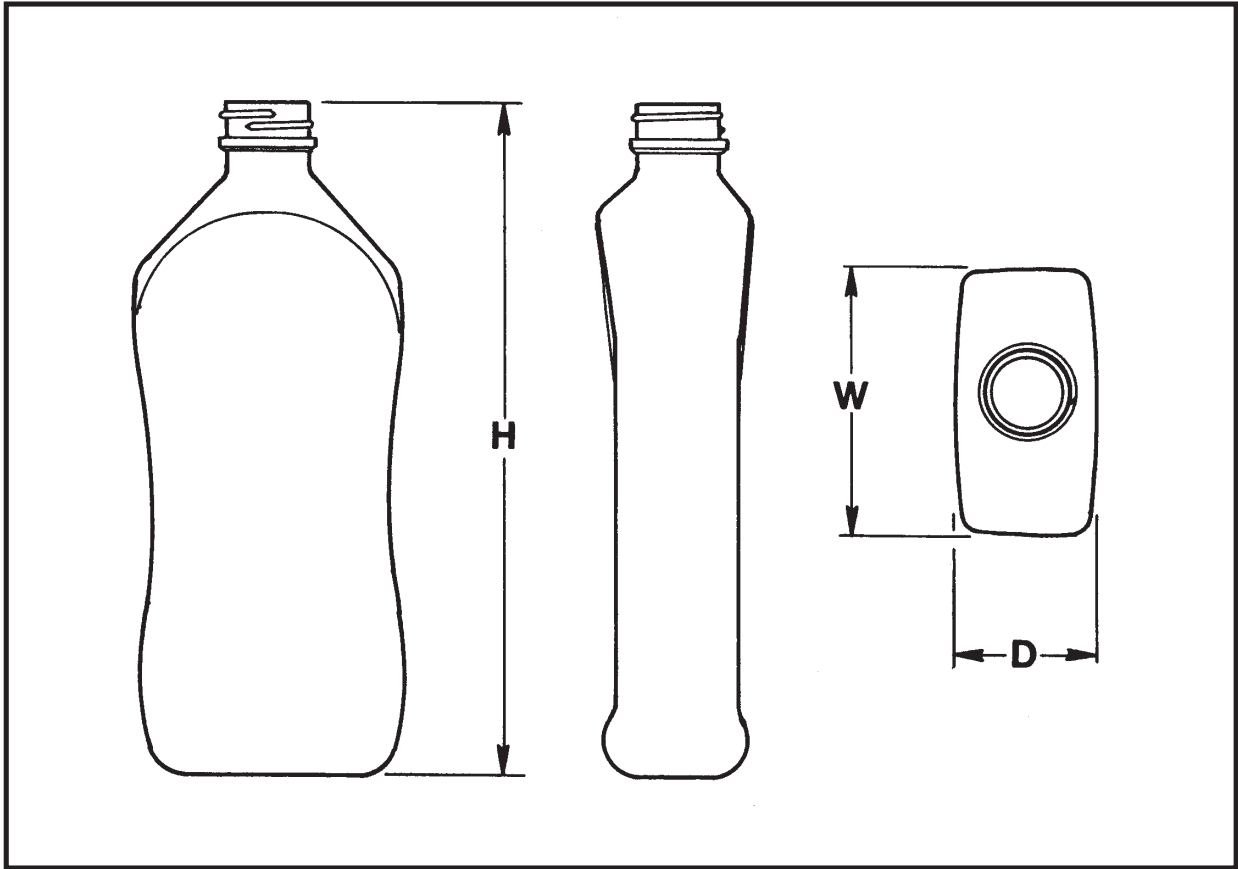

PINCH WAIST OBLONG

CAPACITY	NECKS	MATERIAL	HEIGHT	WIDTH	DEPTH
16 oz	28-400	HDPE	8.00"	3.11"	1.65"

SUPER GRIP OBLONG

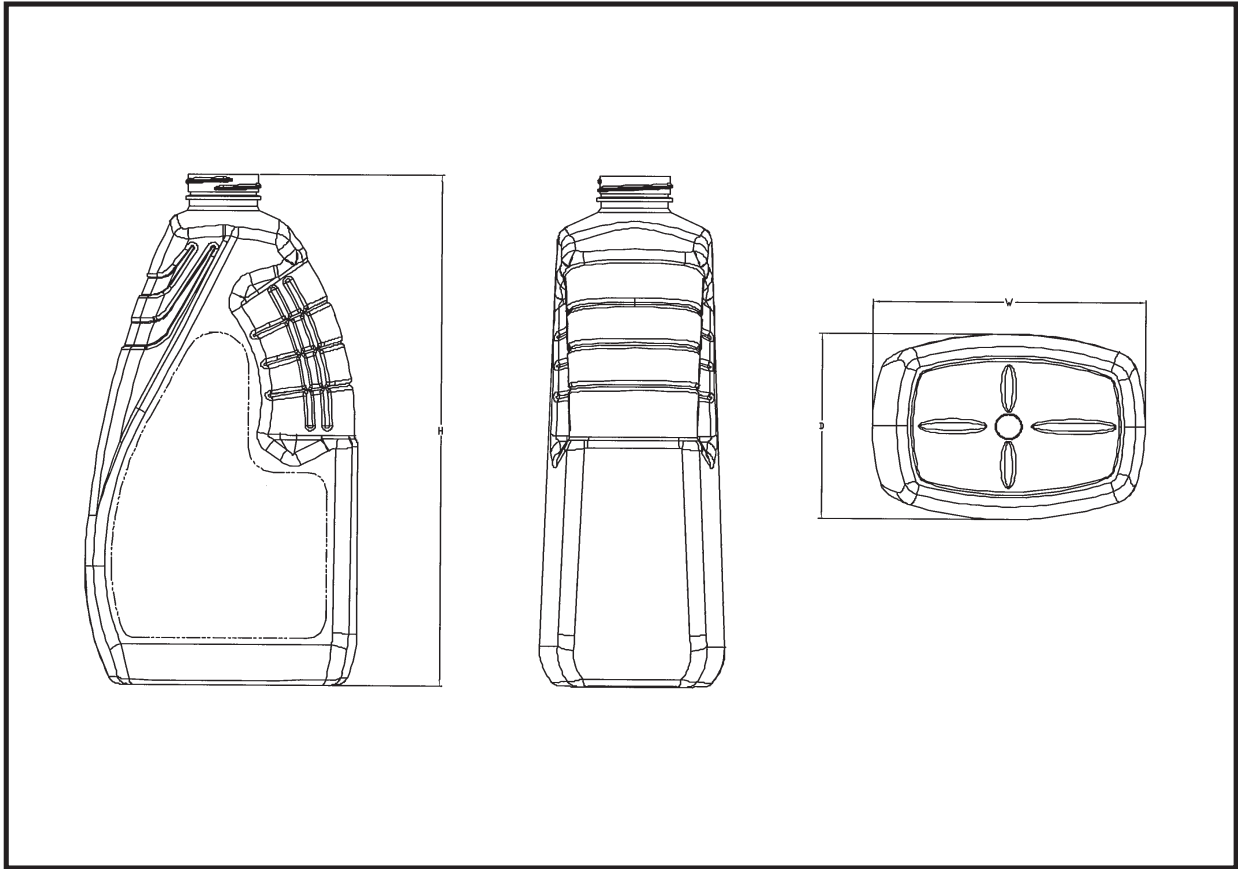

SUPER GRIP OBLONG

CAPACITY	NECKS	MATERIAL	HEIGHT	WIDTH	DEPTH
32 oz	28-400	OPET	8.16"	4.33"	2.814"
48 oz	38-400	OPET	9.085"	4.96"	3.219"
64 oz	38-400	OPET	9.588"	5.341"	3.64"

Design Patent #D600,561

HANDLEWARE OBLONG

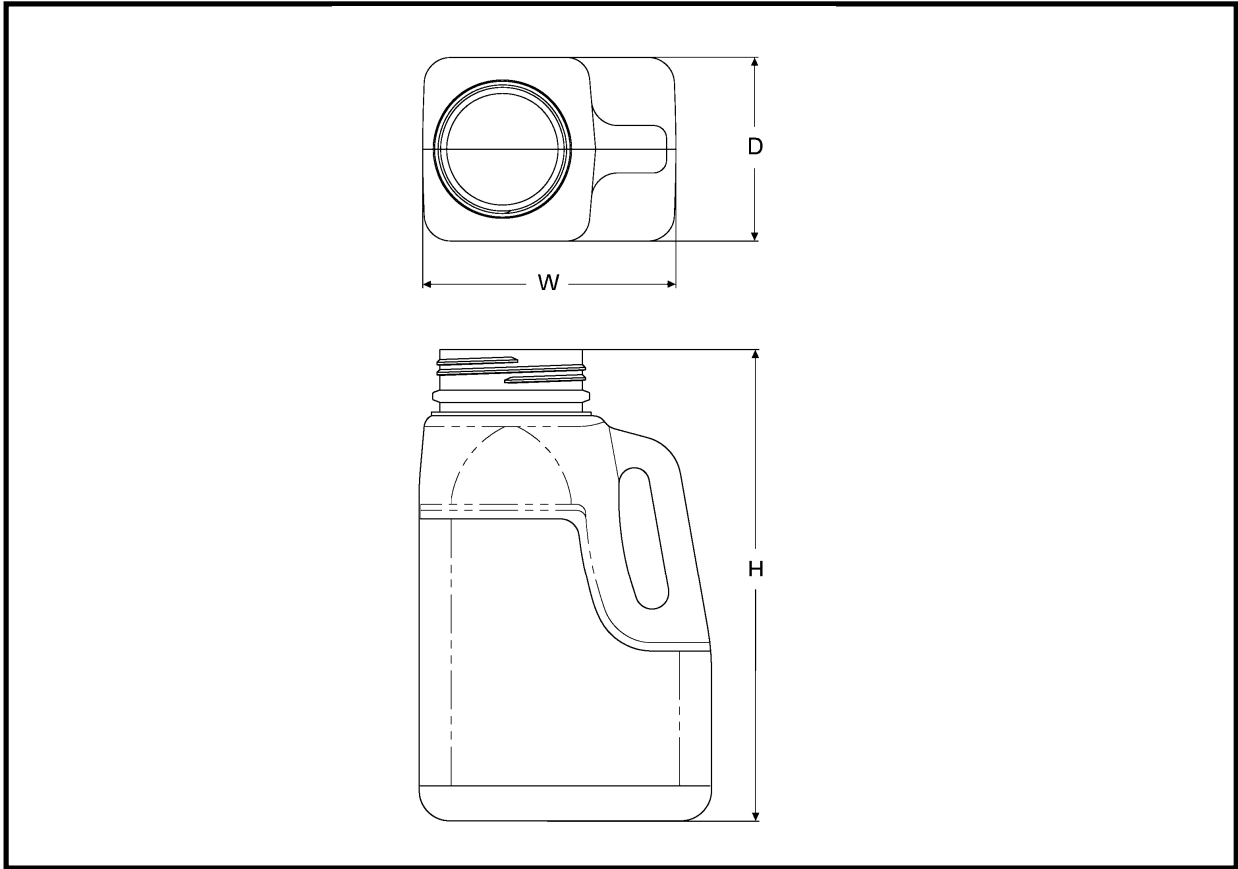

HANDLEWARE OBLONG

CAPACITY	NECKS	MATERIAL	HEIGHT	WIDTH	DEPTH
48 oz	63-485 Tall	HDPE	7.75"	4.815"	3.48"

GREAT LAKES HANDLEWARE OBLONG

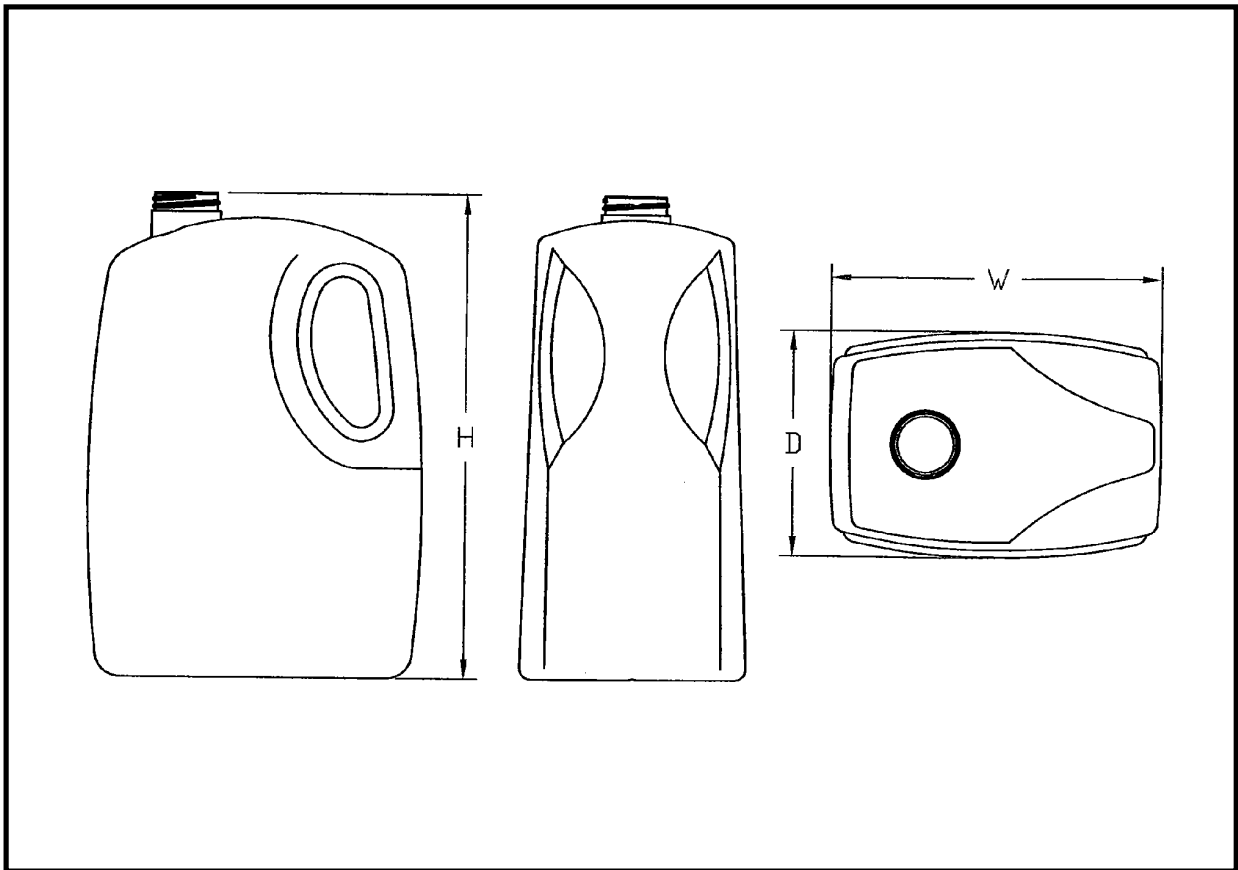

GREAT LAKES HANDLEWARE OBLONG

CAPACITY	NECKS	MATERIAL	HEIGHT	WIDTH	DEPTH
128 oz / 4 Liter	33-400 .445" H	HDPE	10.749"	7.375"	4.95"
128 oz / 4 Liter	38-400 .415" H	HDPE	10.801"	7.375"	4.95"

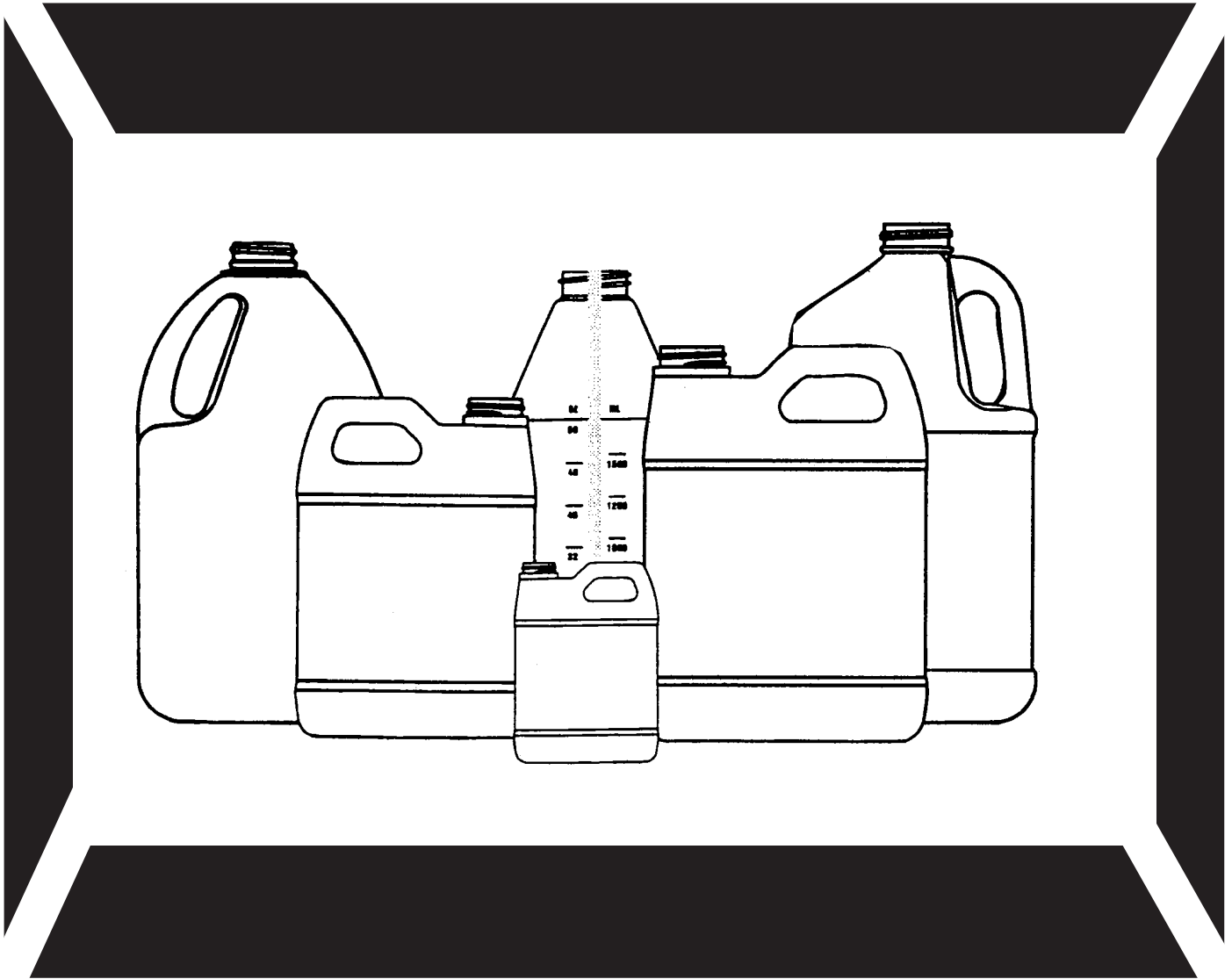

RECTANGULARS & SQUARES

Where great ideas take shape.

PINCH GRIP SQUARE

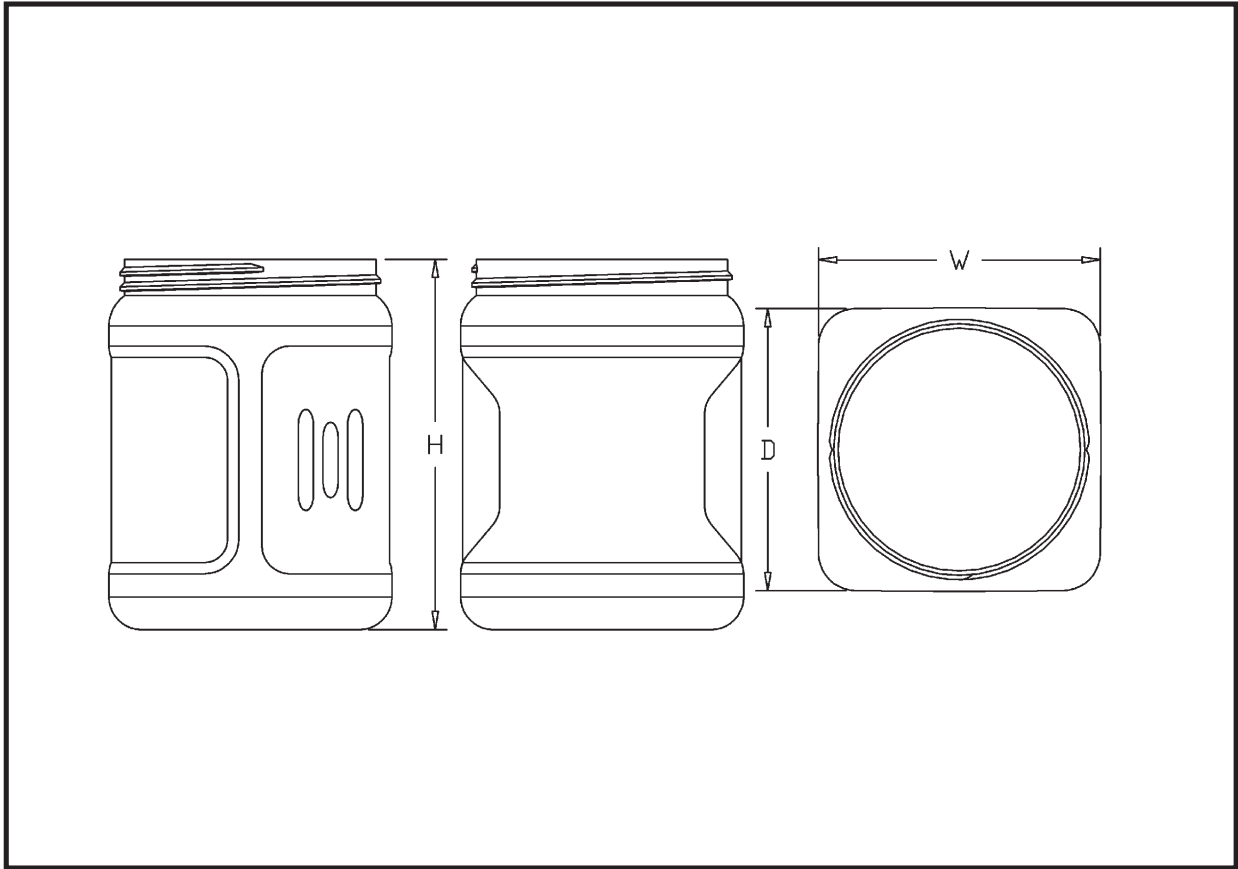

PINCH GRIP SQUARE

CAPACITY	NECKS	MATERIAL	HEIGHT	WIDTH	DEPTH
30 oz	89-400 .970"	HDPE	4.965"	3.8"	3.8"

NAUTICAL SQUARE

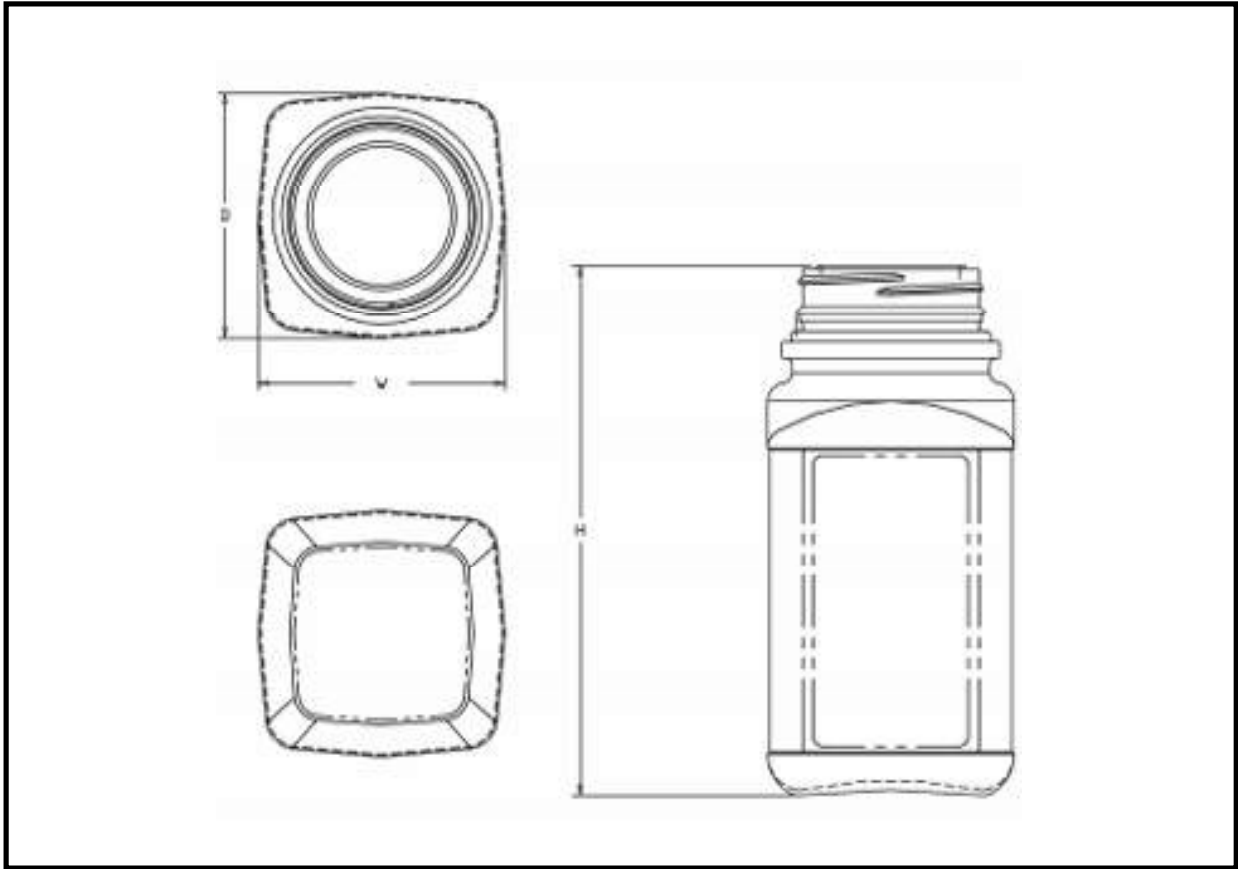

NAUTICAL SQUARE

CAPACITY	NECKS	MATERIAL	HEIGHT	WIDTH	DEPTH
17 oz / 500 ml	58-400	HDPE	5.98"	2.96"	2.96"
17 oz / 500 ml	58mm Pano T/E	HDPE	6.36"	2.96"	2.96"

SIMPLE SQUARE

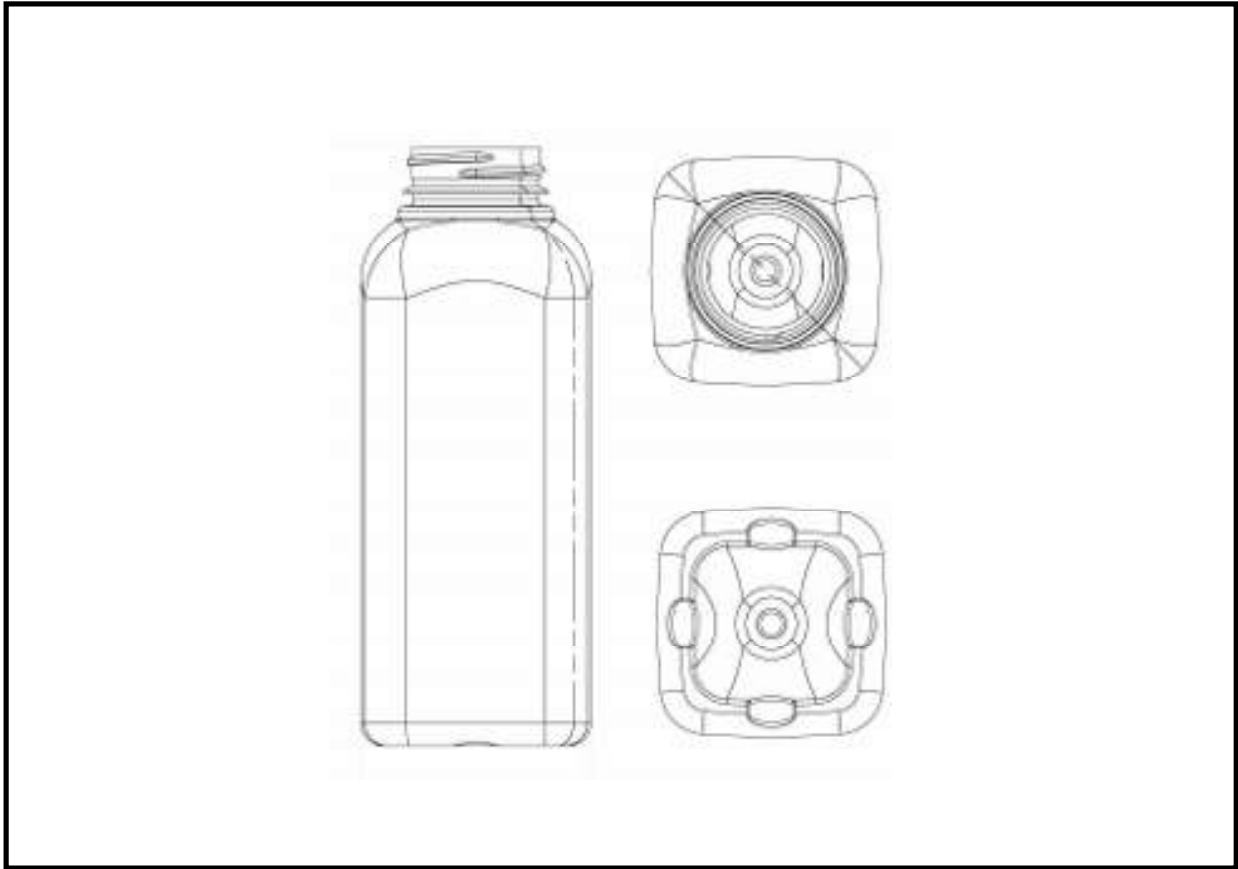

SIMPLE SQUARE

CAPACITY	NECKS	MATERIAL	HEIGHT	WIDTH	DEPTH
16 oz	38-400	OPET	6.375"	2.45"	2.45"

TEXTURED SQUARE

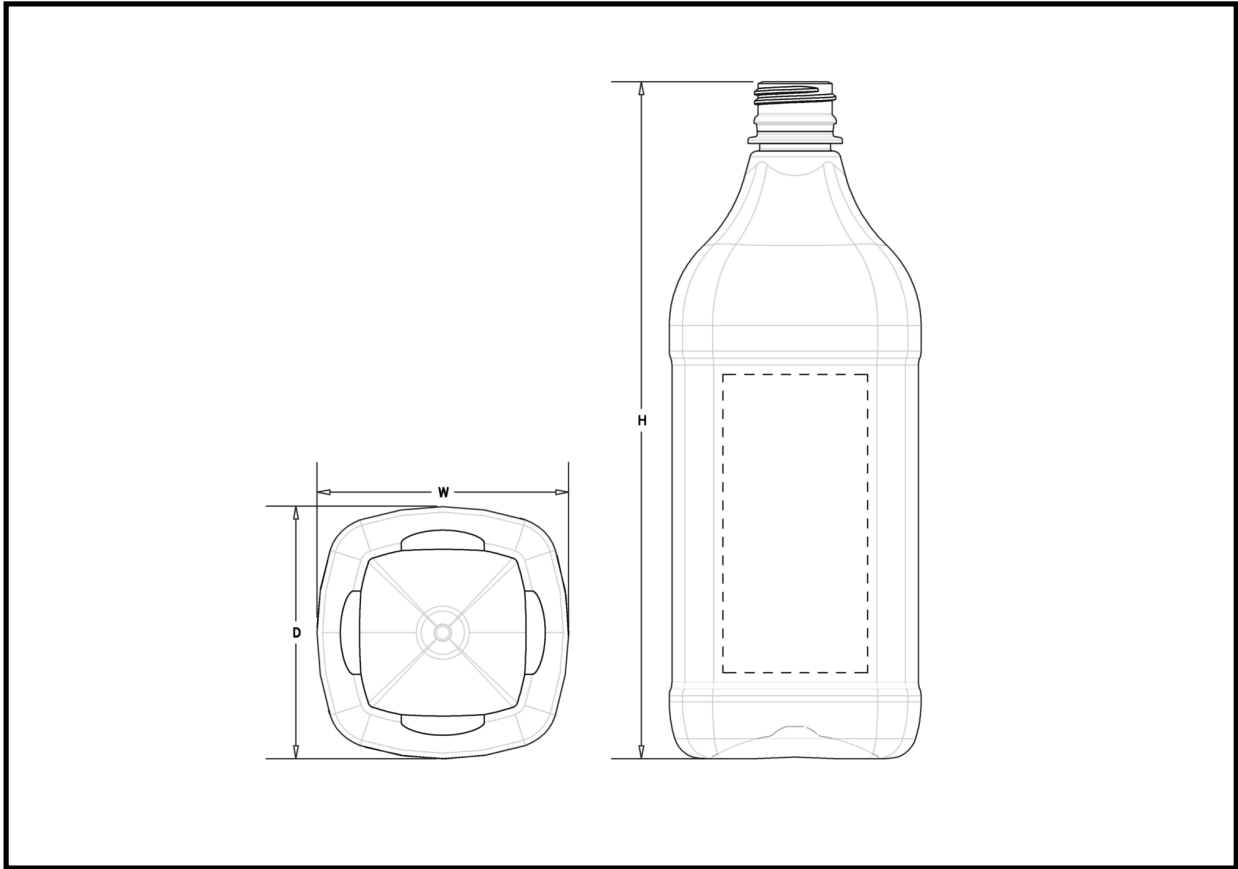

TEXTURED SQUARE

CAPACITY	NECKS	MATERIAL	HEIGHT	WIDTH	DEPTH
32 oz / 1 Liter	28mm KERR Tamper Evident	OPET	8.957"	3.335"	3.335"
32 oz / 1 Liter	28-400	OPET	8.678"	3.335"	3.335"
32 oz / 1 Liter	32mm Bericap	OPET	8.551"	3.335"	3.335"

BEVELED SQUARE

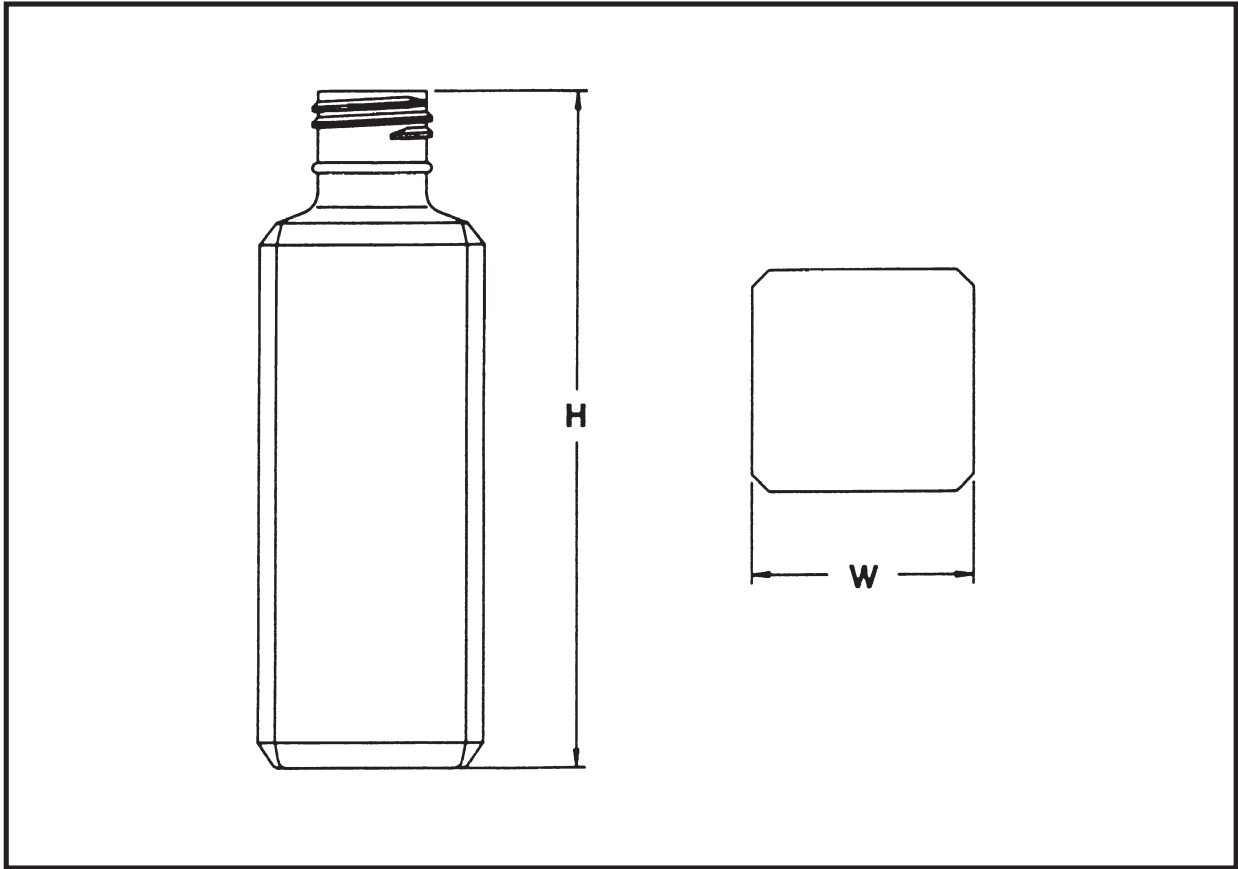

BEVELED SQUARE

CAPACITY	NECKS	MATERIAL	HEIGHT	WIDTH	DEPTH
32 oz / 1 Liter	28-410	HDPE	9.00"	2.91"	2.91"

RECTANGULAR

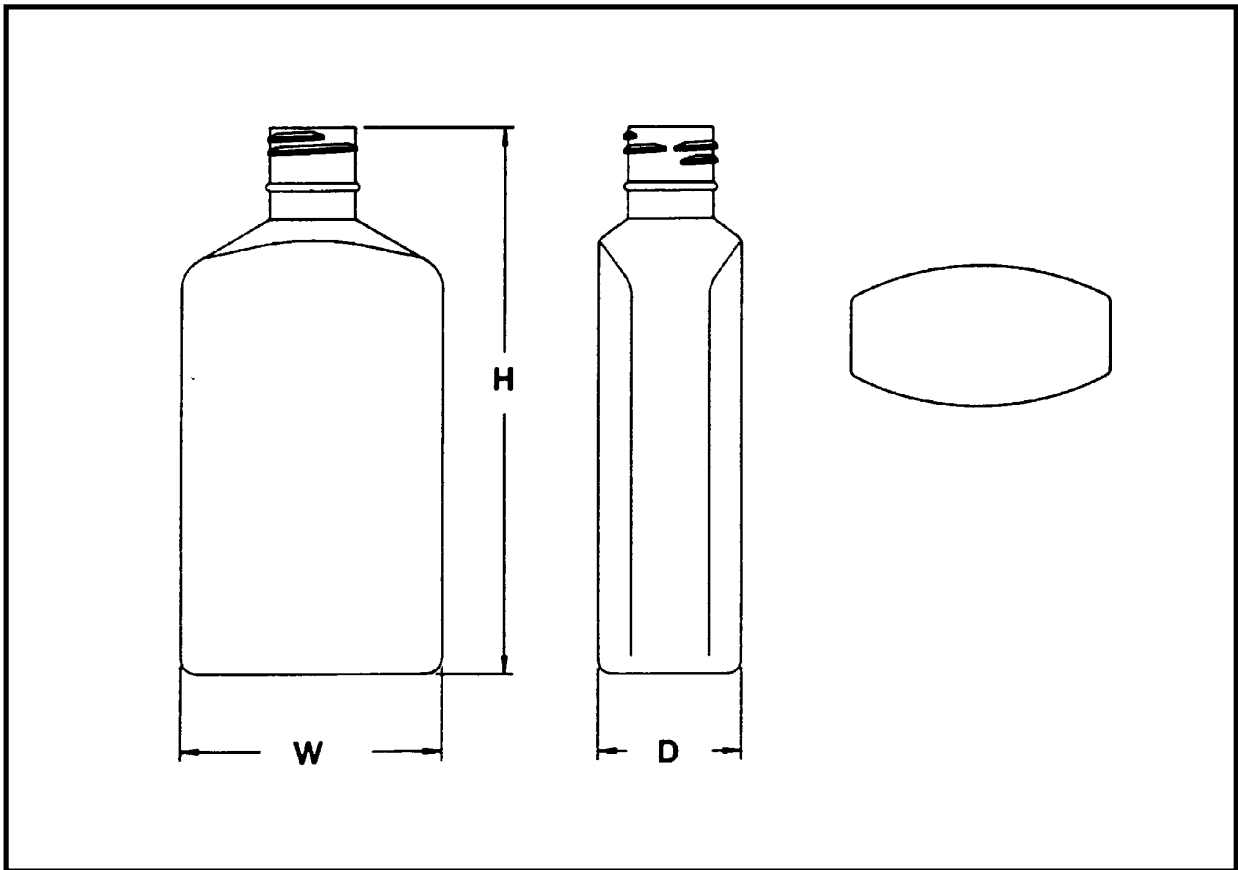

RECTANGULAR

CAPACITY	NECKS	MATERIAL	HEIGHT	WIDTH	DEPTH
10 /10.22 oz	28-415	PVC	6.41"	2.99"	1.55"

Secondary capacity measurement represents cosmetic fill point to base of neck.

PLASTIC BOTTLE CORPORATION

28055 North Ashley Circle, Suite 110
 Libertyville, IL 60048-9635
 847-367-1900
 Fax: 847-367-1990
 www.plasticbottle.com

F STYLE JUGS

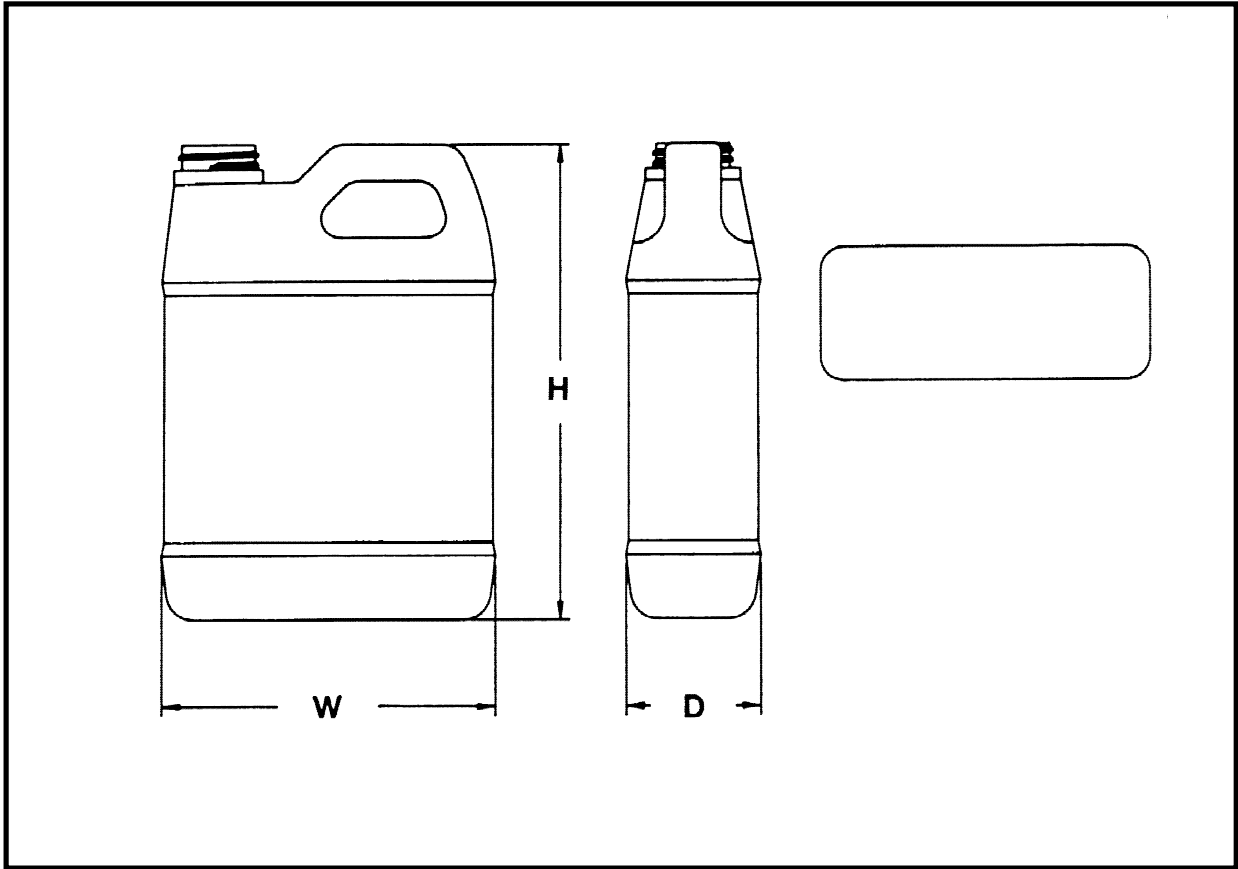

F STYLE JUGS

CAPACITY	NECKS	MATERIAL	HEIGHT	WIDTH	DEPTH
8 oz / 250 ml	28-400 .466" H	PVC or HDPE	4.23"	3.36"	1.71"
32 oz	28mm-Tall	PVC	7.99"	5.13"	2.11"
32 oz	33-400 .403" H	PVC or PETG	7.57"	5.13"	2.11"
32 oz	33-400 .455" H	PVC	7.62"	5.13"	2.11"
32 oz	38-400	PVC or PETG	7.58"	5.13"	2.11"

F STYLE JUGS

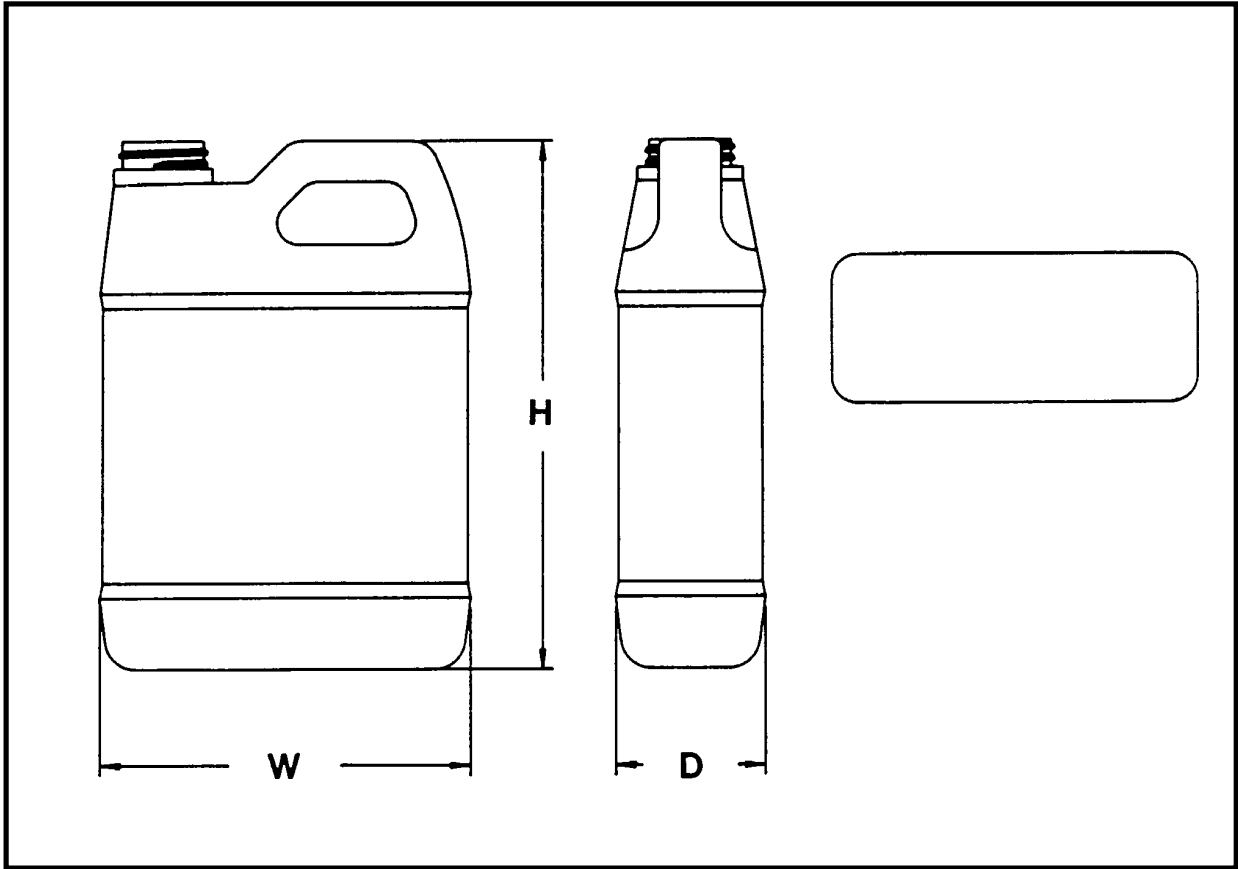

F STYLE JUGS

CAPACITY	NECKS	MATERIAL	HEIGHT	WIDTH	DEPTH
64 oz	28-400 .485" H	PVC	9.025"	6.23"	2.90"
64 oz	28mm Tall	PVC	9.56"	6.23"	2.90"
64 oz	28mm .515" H	PVC	9.03"	6.23"	2.90"
64 oz	38-400	PVC	9.02"	6.23"	2.90"
128 oz	28mm Tall	PVC	11.30"	7.50"	4.08"
128 oz	38-400	PVC	10.76"	7.50"	4.08"

PLASTIC BOTTLE CORPORATION

28055 North Ashley Circle, Suite TTU
 Libertyville, IL 60048-9635
 847-367-1900
 Fax: 847-367-1990
 www.plasticbottle.com

F STYLE JUGS

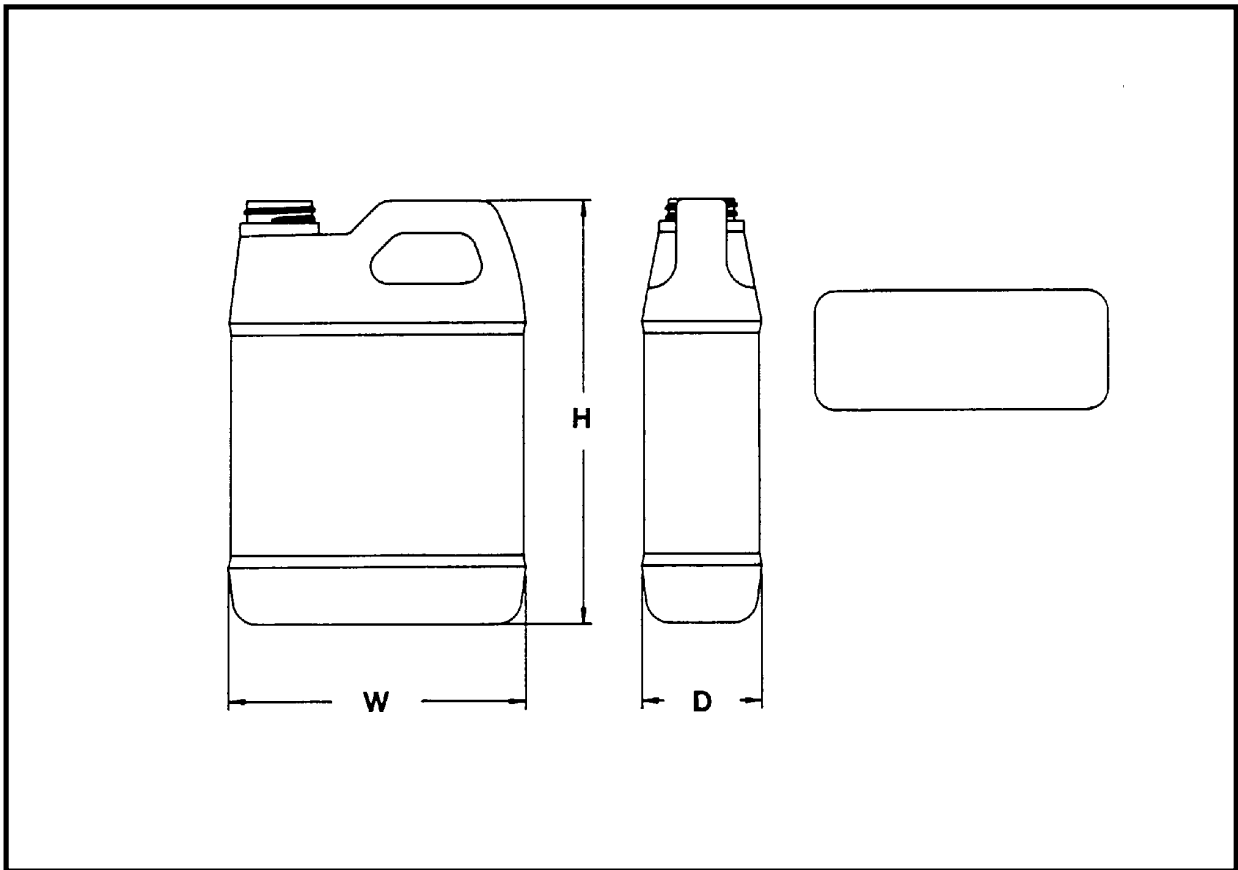

F STYLE JUGS

CAPACITY	NECKS	MATERIAL	HEIGHT	WIDTH	DEPTH
8 oz / 250 ml	28-400	HDPE	4.771"	3.112"	1.70"
8 oz / 250 ml	33-400	HDPE	4.771"	3.112"	1.70"
16 oz / 500 ml	28-400	HDPE	6.10"	4.10"	1.94"
16 oz / 500 ml	33-400	HDPE	6.10"	4.10"	1.94"
24 oz	33-400	HDPE	7.18"	4.50"	2.095"
32 oz	33-400	HDPE	7.59"	5.27"	2.25"
32 oz	38-400	HDPE	7.59"	5.27"	2.25"

Pressure Sensitive Label Application Available
 Available with or without view striping

Pg. 153.00

Where great ideas take shape.

F STYLE JUGS

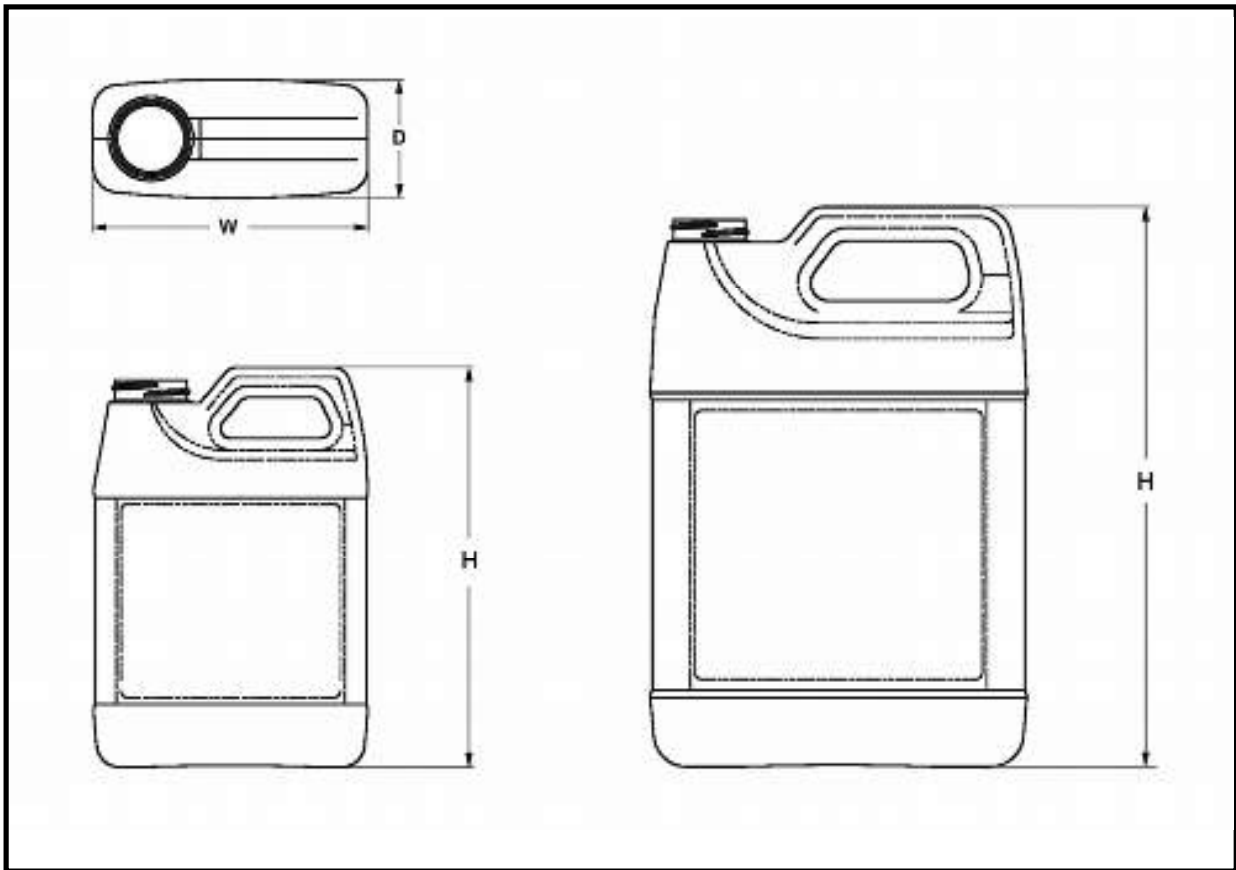

F STYLE JUGS

CAPACITY	NECKS	MATERIAL	HEIGHT	WIDTH	DEPTH
1 Liter	38-400	HDPE	7.62"	5.205"	2.25"
3 Liter	38-400	HDPE	10.627"	7.14"	3.42"

F STYLE JUG WITH GRADUATIONS

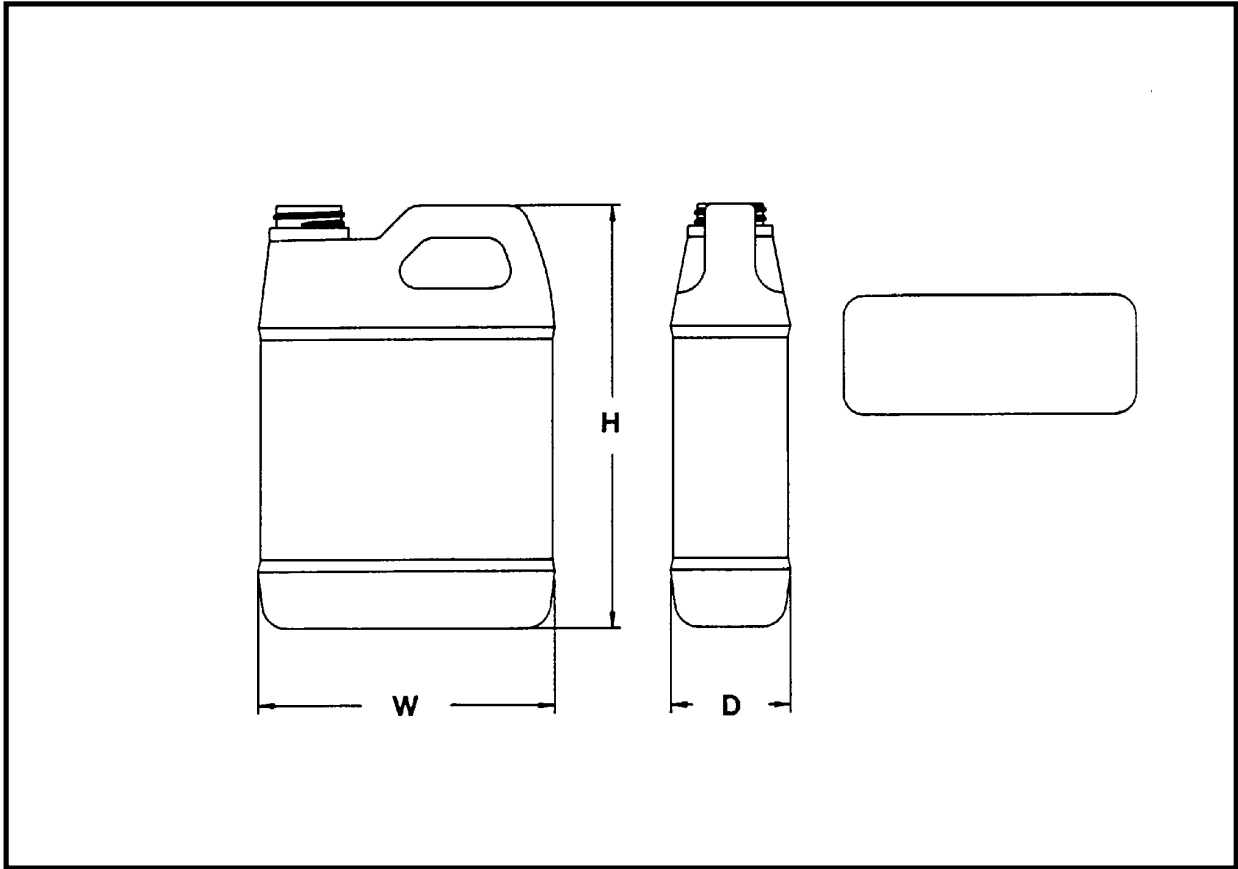

F STYLE JUG WITH GRADUATIONS

CAPACITY	NECKS	MATERIAL	HEIGHT	WIDTH	DEPTH
64 oz	33-400	HDPE	9.03"	5.16"	3.63"
64 oz	38-400	HDPE	9.03"	5.16"	3.63"
2 Liter	33-400	HDPE	9.41"	5.16"	3.63"
2 Liter	38-400	HDPE	9.41"	5.16"	3.63"

Pressure Sensitive Label Application Available
 Engraved with ml and oz graduations
 Available with or without view striping

F STYLE JUG-TALL

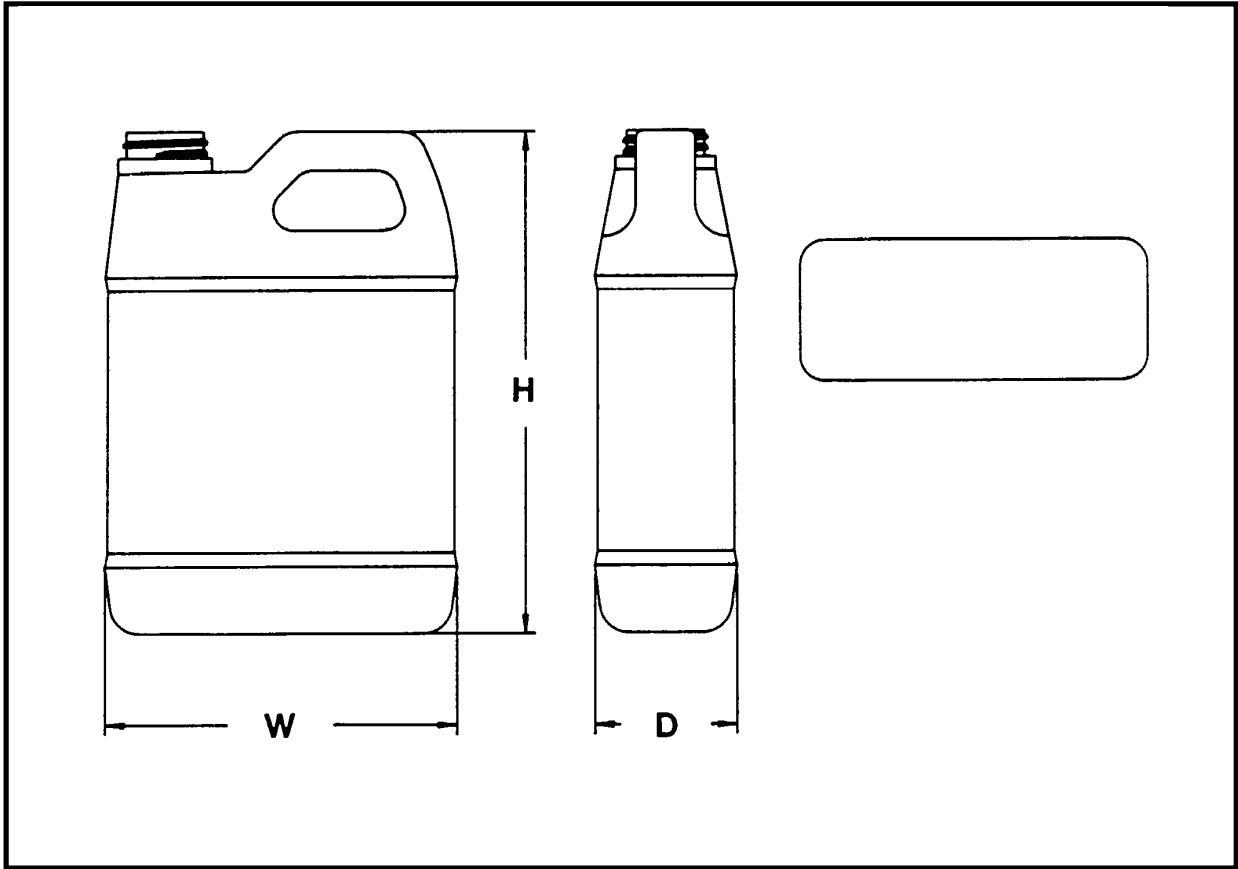

F STYLE JUG-TALL

CAPACITY	NECKS	MATERIAL	HEIGHT	WIDTH	DEPTH
64 oz	38-400	HDPE	10.115"	6.20"	2.97"

SLANT HANDLE F STYLE JUG

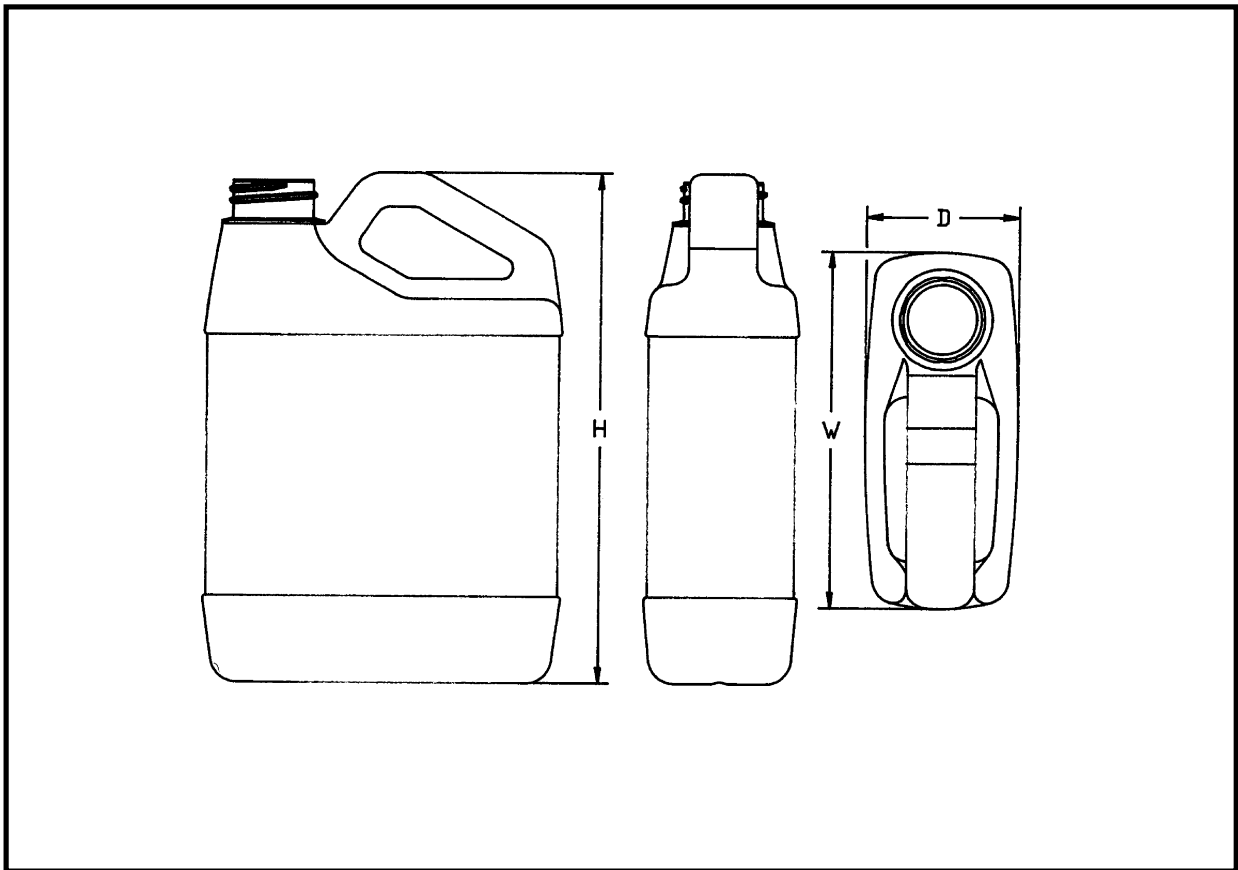

SLANT HANDLE F STYLE JUG

CAPACITY	NECKS	MATERIAL	HEIGHT	WIDTH	DEPTH
24 oz	33-400	HDPE	7.18"	4.50"	2.095"
32 oz/ 1 Liter	33-400	HDPE	7.46"	5.218"	2.24"

Pressure Sensitive Label Application Available
 Available with or without view striping

SLANT HANDLE F STYLE JUGS

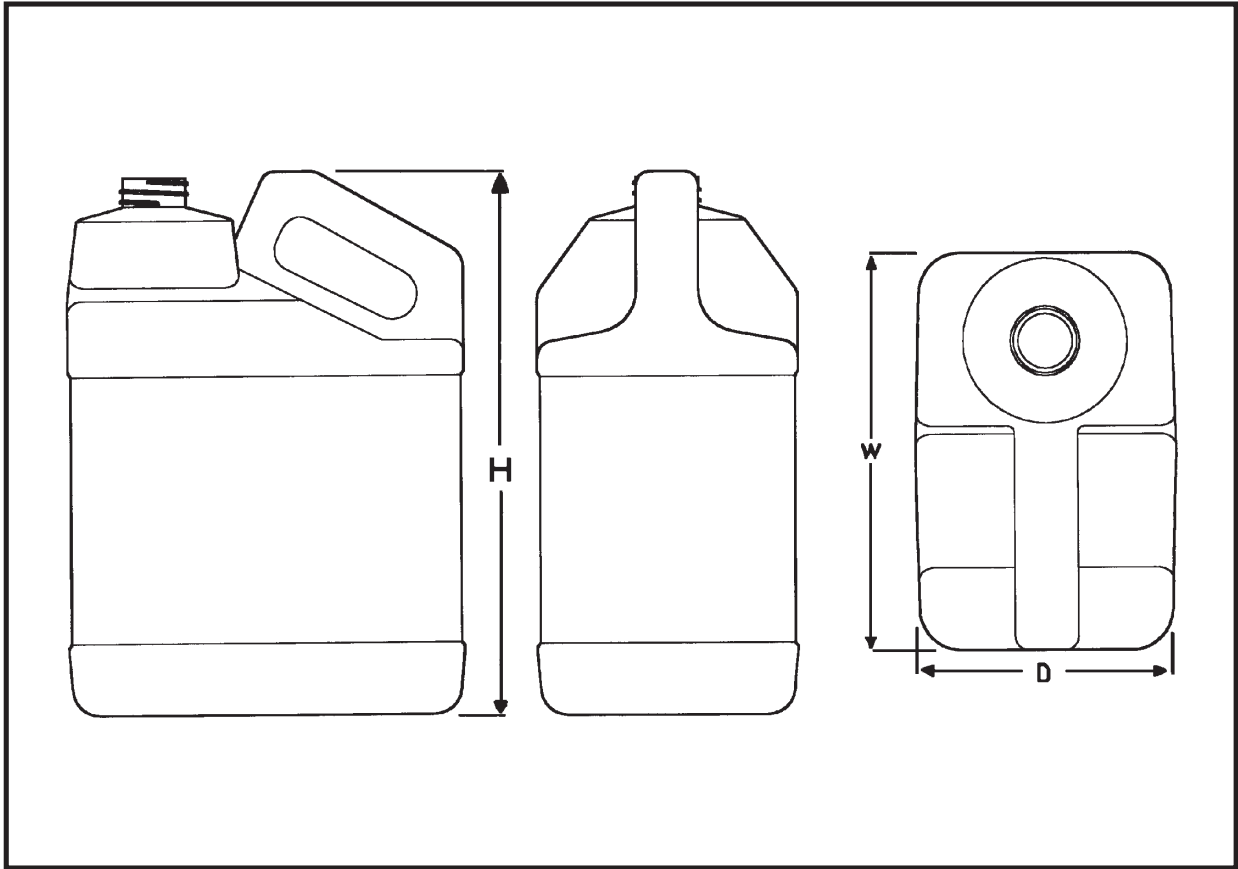

SLANT HANDLE F STYLE JUGS

CAPACITY	NECKS	MATERIAL	HEIGHT	WIDTH	DEPTH
128 oz / 4 Liter	33-400	HDPE	9.88"	7.20"	4.73"
128 oz / 4 Liter	38-400 .670"	HDPE	9.88"	7.20"	4.73"
128 oz / 4 Liter	53-400 .625"	HDPE	9.88"	7.20"	4.73"
128 oz / 4 Liter	63-485 Rieke*	HDPE	10.06"	7.20"	4.73"

* Closure available from Plastic Bottle Corporation

GRIPPED SLANT HANDLE F STYLE JUGS

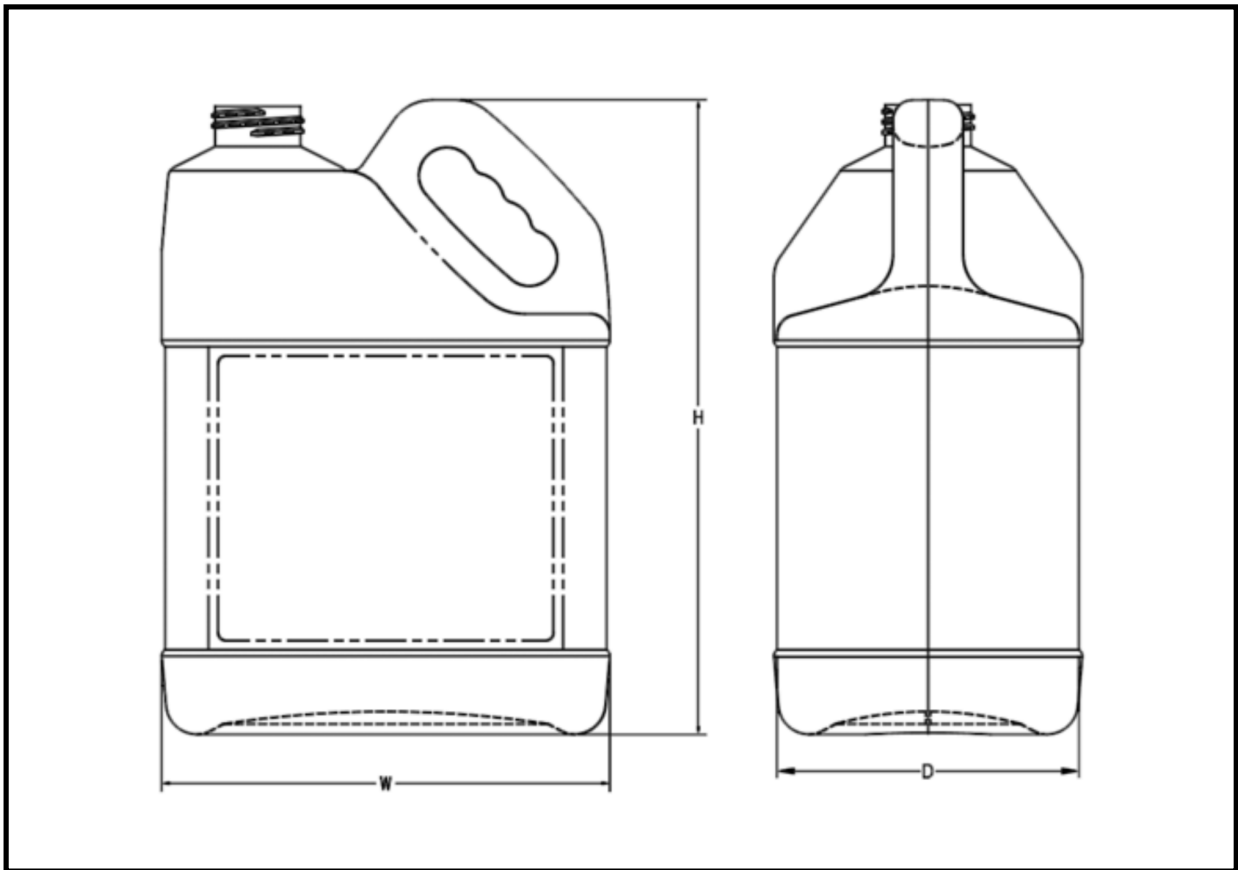

GRIPPED SLANT HANDLE F STYLE JUGS

CAPACITY	NECKS	MATERIAL	HEIGHT	WIDTH	DEPTH
128 oz / 4 Liter	38-400	HDPE	10.14"	7.17"	4.932"
160 oz / 5 Liter	38-400	HDPE	12.108"	7.17"	4.932"

SLANT HANDLE F STYLE JUGS

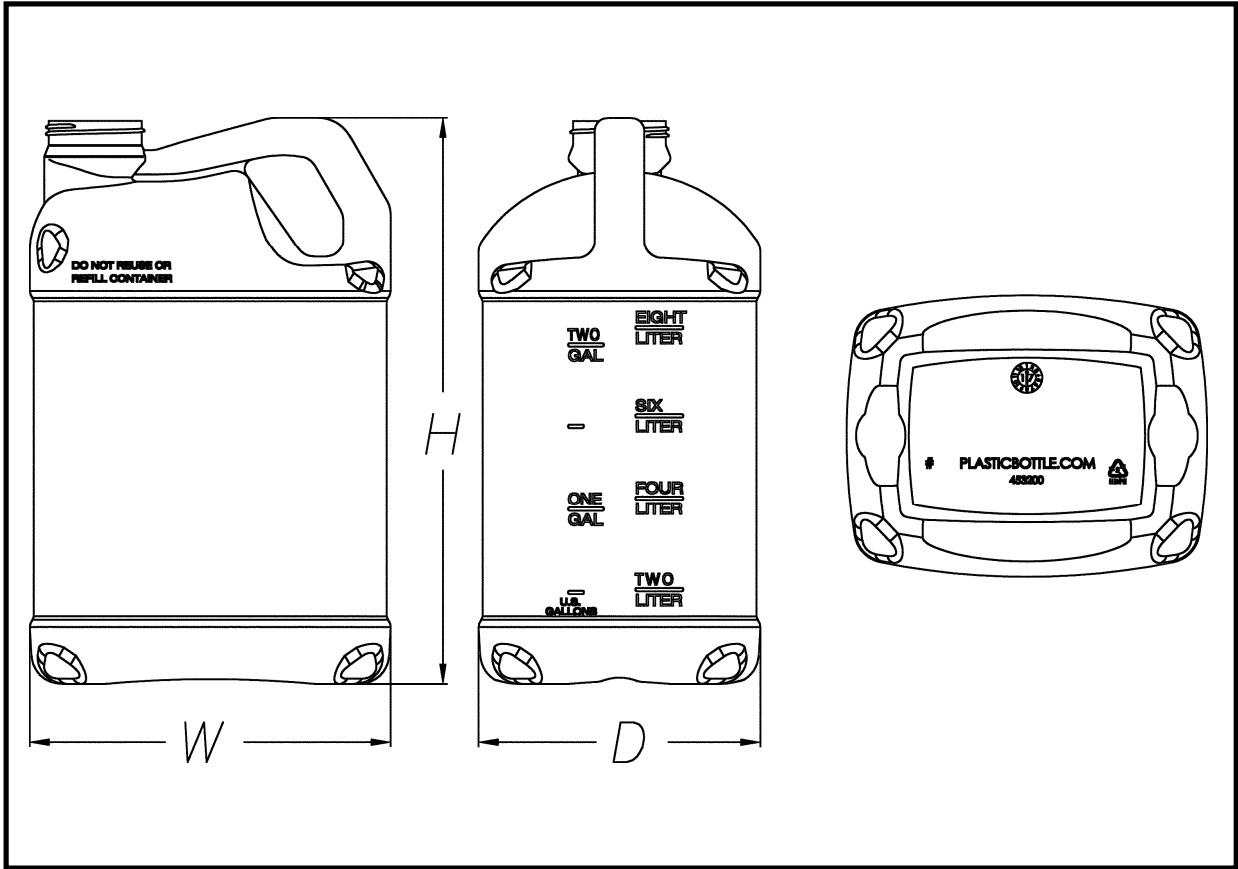

SLANT HANDLE F STYLE JUGS

CAPACITY	NECKS	MATERIAL	HEIGHT	WIDTH	DEPTH
2.5 Gallon / 10 Liter	63mm AntiGlug	HDPE	14.326"	9.125"	7.125"

Engraved with liter and gallon graduations.

WIDE MOUTH SQUARE

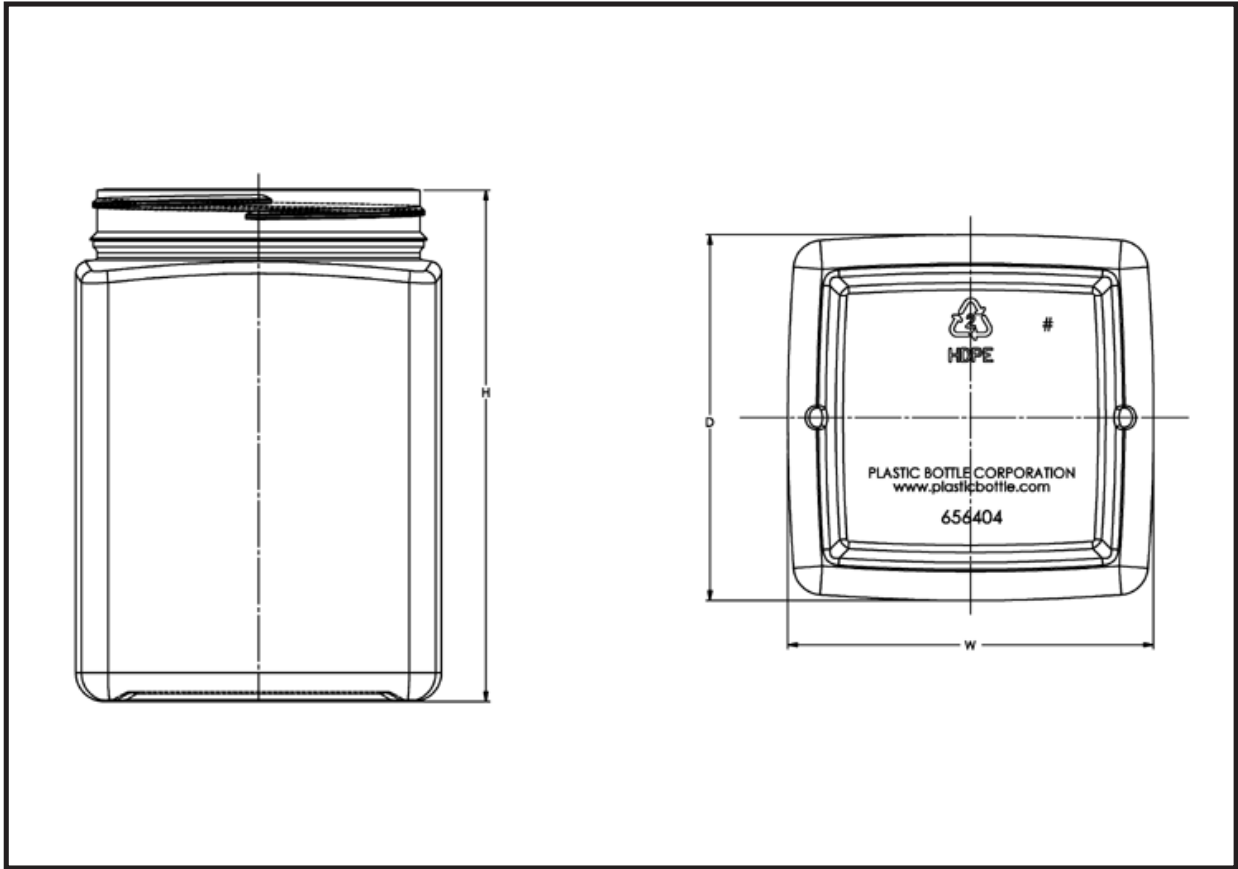

WIDE MOUTH SQUARE

CAPACITY	NECKS	MATERIAL	HEIGHT	WIDTH	DEPTH
2 Liter	110MM Pano Tamper Evident	HDPE	6.64"	4.75"	4.75"

INDUSTRIAL SQUARE JUGS

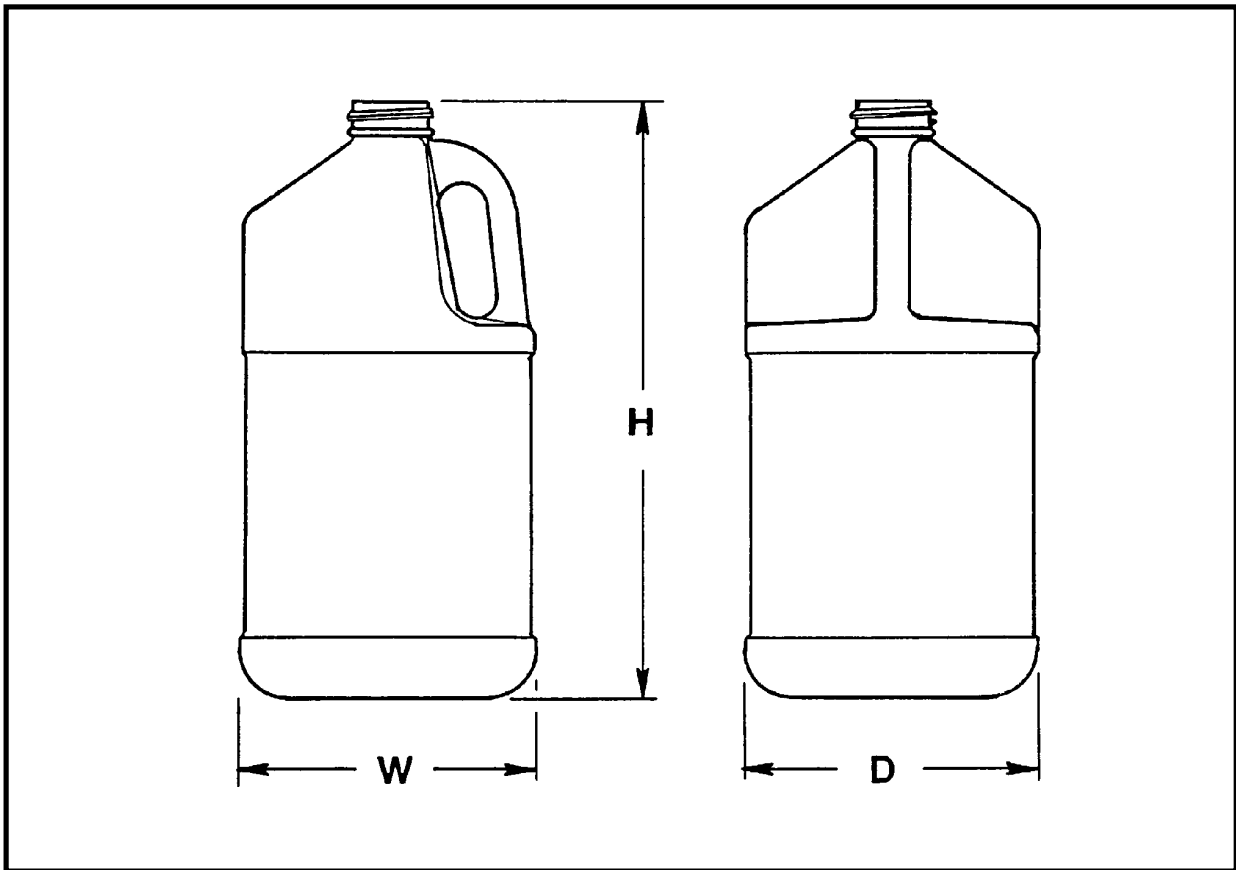

INDUSTRIAL SQUARE JUGS

CAPACITY	NECKS	MATERIAL	HEIGHT	WIDTH	DEPTH
64 oz	28-480	PVC	8.816"	4.50"	4.43"
64 oz	38-400	PVC	8.76"	4.50"	4.43"
2 Liter	28-480	PVC	9.126"	4.50"	4.43"
2 Liter	38-400	PVC	9.085"	4.50"	4.43"
128 oz	38-400	PVC	10.91"	5.64"	5.58"
4 Liter	38-400	PVC	11.32"	5.64"	5.58"

SURE GRIP SQUARE

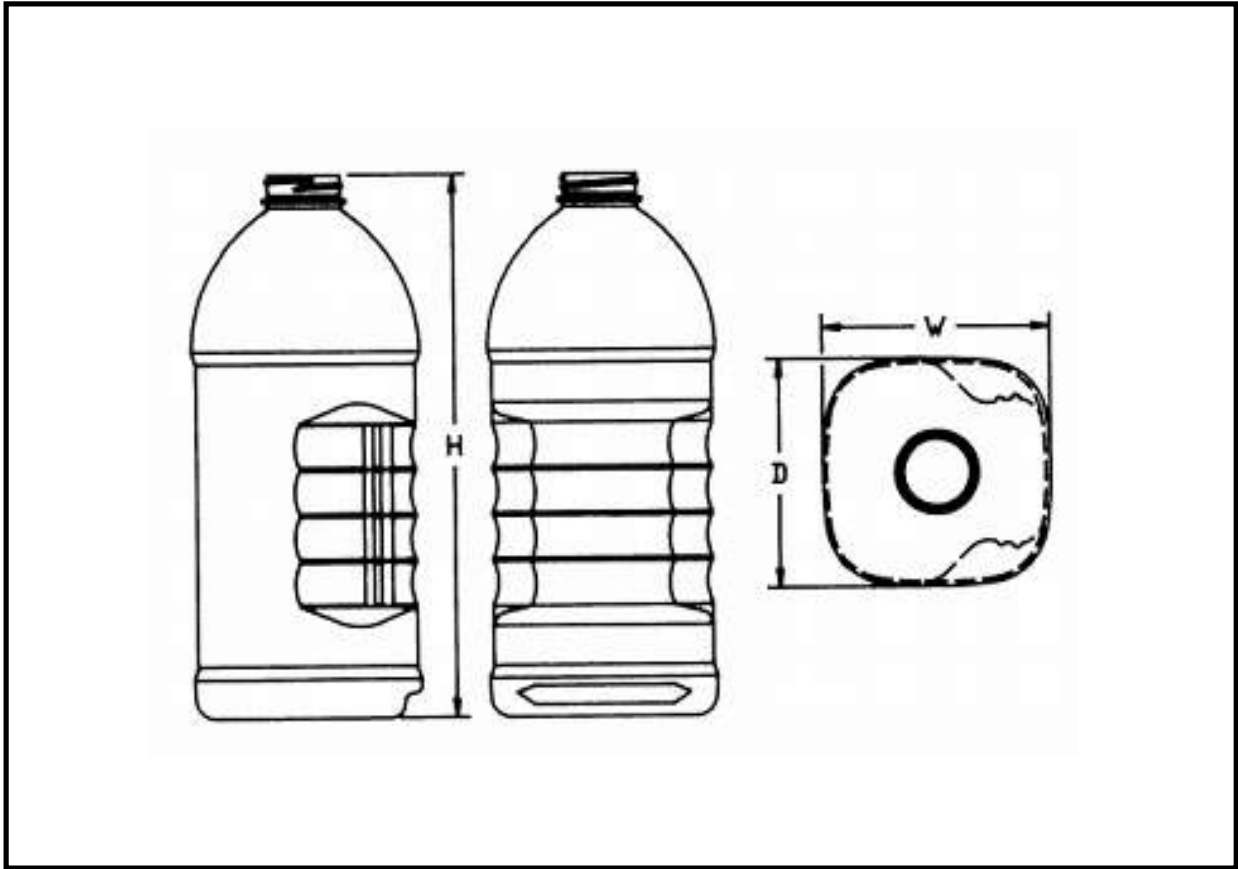

SURE GRIP SQUARE

CAPACITY	NECKS	MATERIAL	HEIGHT	WIDTH	DEPTH
64 oz / 2 Liter	38-400	OPET	10.299"	4.331"	4.331"

SURE GRIP SQUARE

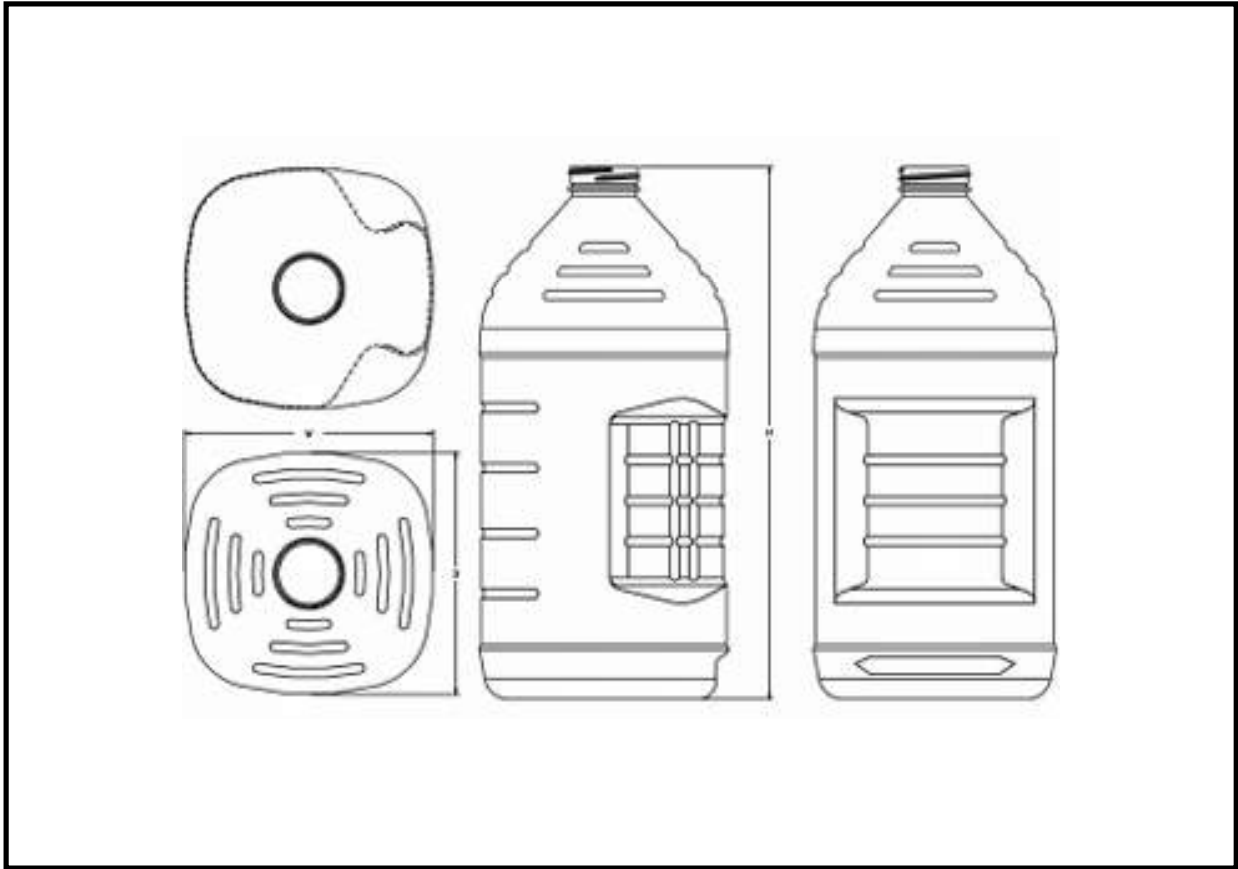

SURE GRIP SQUARE

CAPACITY	NECKS	MATERIAL	HEIGHT	WIDTH	DEPTH
100 oz	38-400	OPET	11.00"	5.00"	5.139"

SURE SQUARE

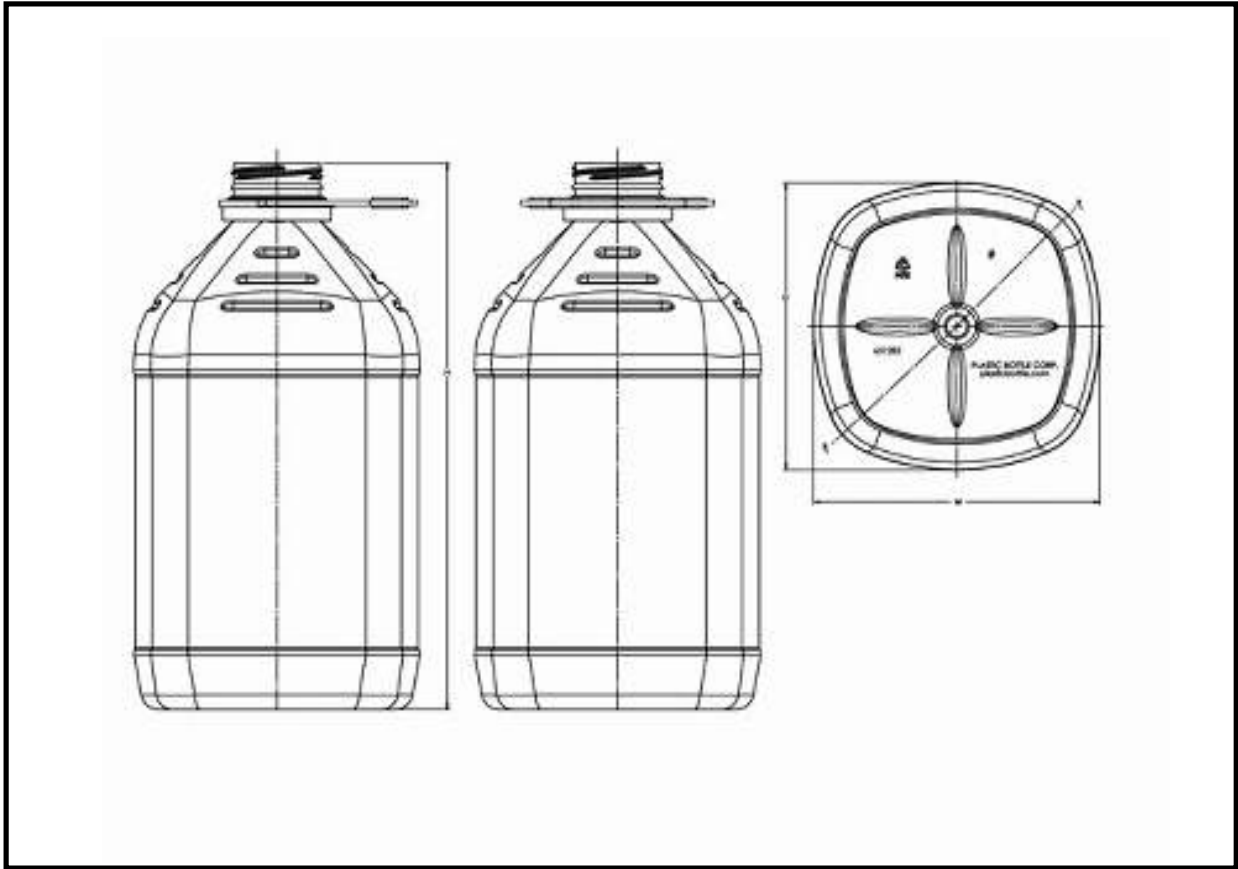

SURE SQUARE

CAPACITY	NECKS	MATERIAL	HEIGHT	WIDTH	DEPTH
128 oz / 4 Liter	48mm Bericap	OPET	11.25"	5.888"	5.888"

GREAT PLAINS INDUSTRIAL SQUARE JUG

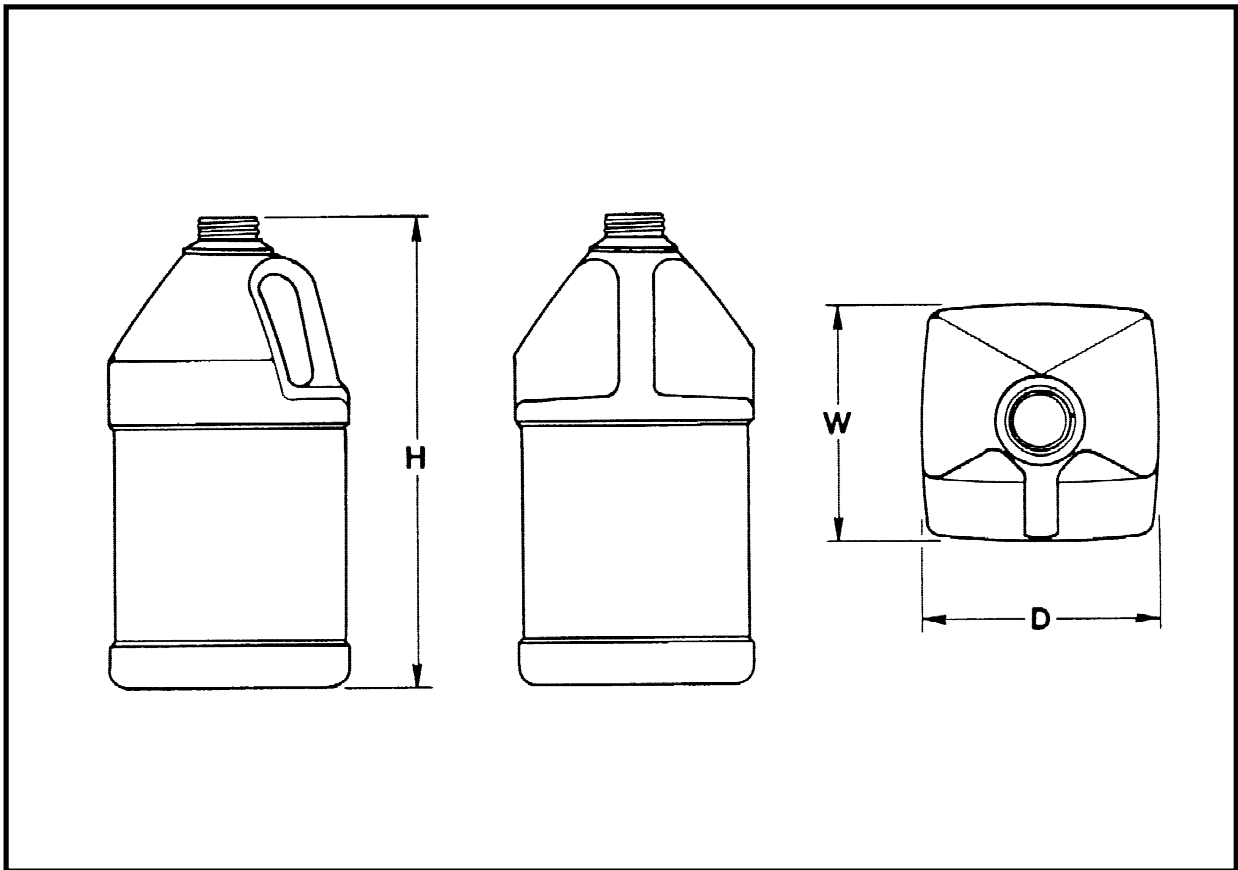

GREAT PLAINS INDUSTRIAL SQUARE JUG

CAPACITY	NECKS	MATERIAL	HEIGHT	WIDTH	DEPTH
128 oz	33-400 .670≈H	HDPE	11.254"	5.75"	5.75"
128 oz	38-400 .525≈H	HDPE	11.16"	5.75"	5.75"

7/06

PLASTIC BOTTLE CORPORATION

28055 North Ashley Circle, Suite 110
Libertyville, IL 60048-9635
847-367-1900
Fax: 847-367-1990
www.plasticbottle.com

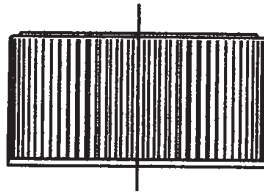
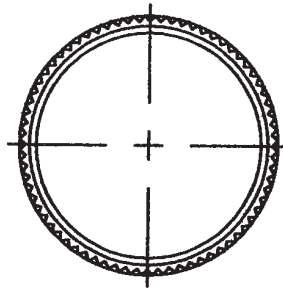

CLOSURES

Where great ideas take shape.

22MM CRC CLOSURE

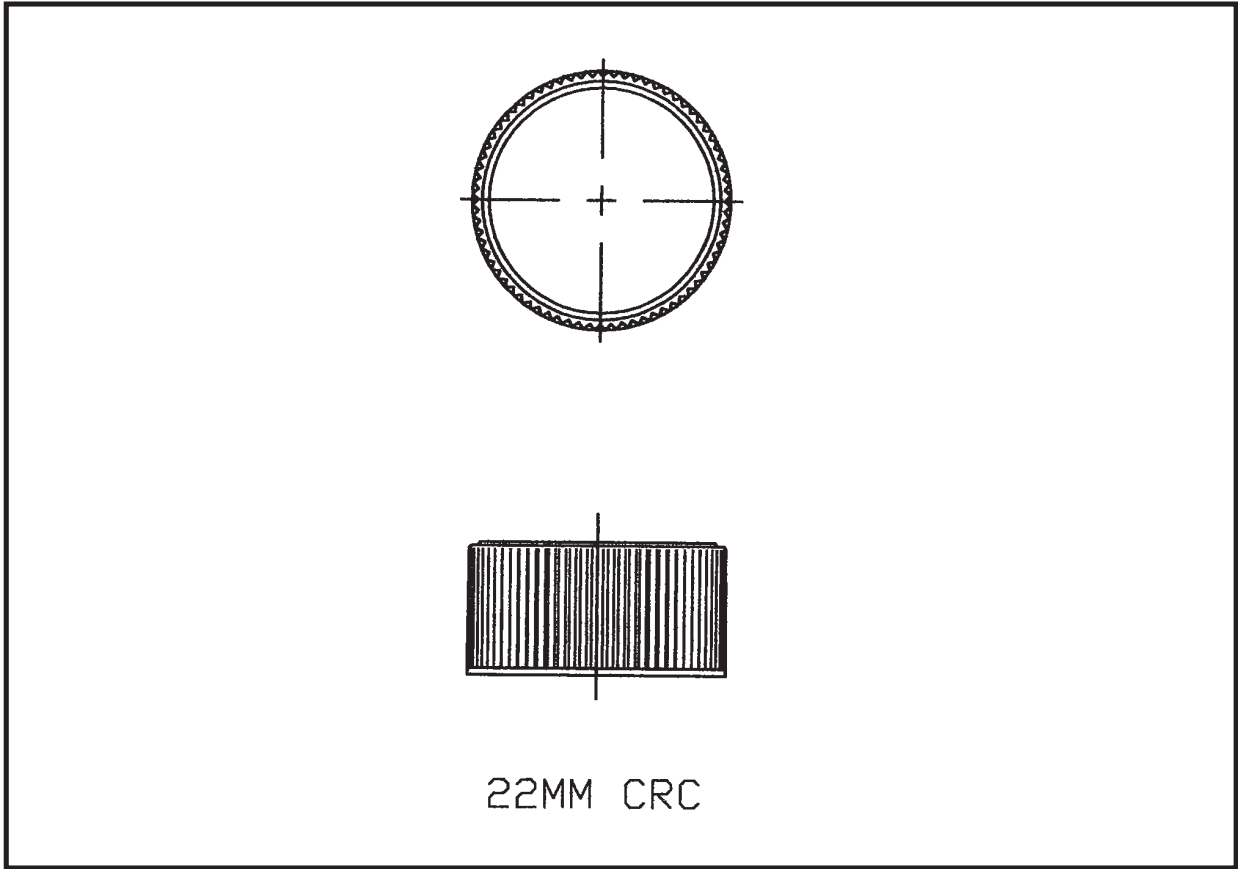

22MM CRC CLOSURE





22MM*





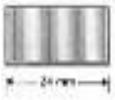

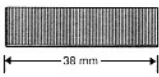

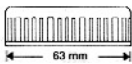
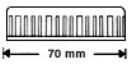
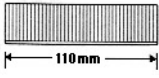
72 Ribs Equally Spaced

Polypropylene

*Fits all standard SPI 22-400 neck finishes

Closures

Closure	Weight	Outer Rib	Resin
24-410 	2.15 grams	100 ribs equally spaced	Polypropylene
28-410 	2.95 grams	110 ribs equally spaced	Polypropylene
38-400 	2.88 grams	144 ribs equally spaced	Polypropylene
38-430V 	7.69 grams	8 ribs equally spaced	Polypropylene
63-485SL 	14.19 grams	48 ribs equally spaced	Polypropylene
70-485SL 	15.13 grams	48 ribs equally spaced	Polypropylene
110-400 	21.55 grams	411 ribs equally spaced	Polypropylene

Closure	Weight	Outer Rib	Resin
28-400 	2.20 grams	110 ribs equally spaced	Polypropylene
33-400 	2.11 grams	100 ribs equally spaced	Polypropylene
38-400CR 	8.08 grams	90 ribs equally spaced	Polypropylene
38-400HW 	3.61 grams	90 ribs equally spaced	Polypropylene
53-400 	4.72 grams	198 ribs equally spaced	Polypropylene
63-485SFR 	14.19 grams	36 ribs equally spaced	Polypropylene
63-485SN 	10.55 grams	24 ribs equally spaced	Polypropylene
89-400 	15.00 grams	338 ribs equally spaced	Polypropylene

White and Black closures are often available from stock. Custom colors have various minimum order quantities.
 Tamper-evident closures require special container finishes.
 To our customers: It is your responsibility to perform thorough testing when choosing a closure and/or liner for your packaging application.
 Samples are available upon request.

PLASTIC BOTTLE CORPORATION

28055 North Ashley Circle, Suite 110
Libertyville, IL 60048-9635
847-367-1900
Fax: 847-367-1990
www.plasticbottle.com



DECORATING

Where great ideas take shape.

Did you know?
We've added capacity for

PRESSURE SENSITIVE

LABELING

Now we can do:
more sizes
more styles
more materials
higher volumes

We'd like to be your full service supplier
for both your container AND labeling needs.
Call today for a quotation.

PLASTIC BOTTLE CORPORATION
(847) 367 1900; Fax: (847) 367 1990

sales@plasticbottle.com

www.plasticbottle.com

Where great ideas take shape.

Did you know?
We've added capacity for

SILK SCREEN PRINTING
of our bottles

Based on the
item and quantity.

We'd like to be your full service supplier
for both your container
AND silk screen printing needs.
Call today for a quotation.

PLASTIC BOTTLE CORPORATION
(847) 367-1900; Fax: (847) 367-1990

sales@plasticbottle.com

www.plasticbottle.com

Where great ideas take shape.

PLASTIC BOTTLE CORPORATION

28055 North Ashley Circle, Suite 110
Libertyville, IL 60048-9635
847-367-1900
Fax: 847-367-1990
www.plasticbottle.com

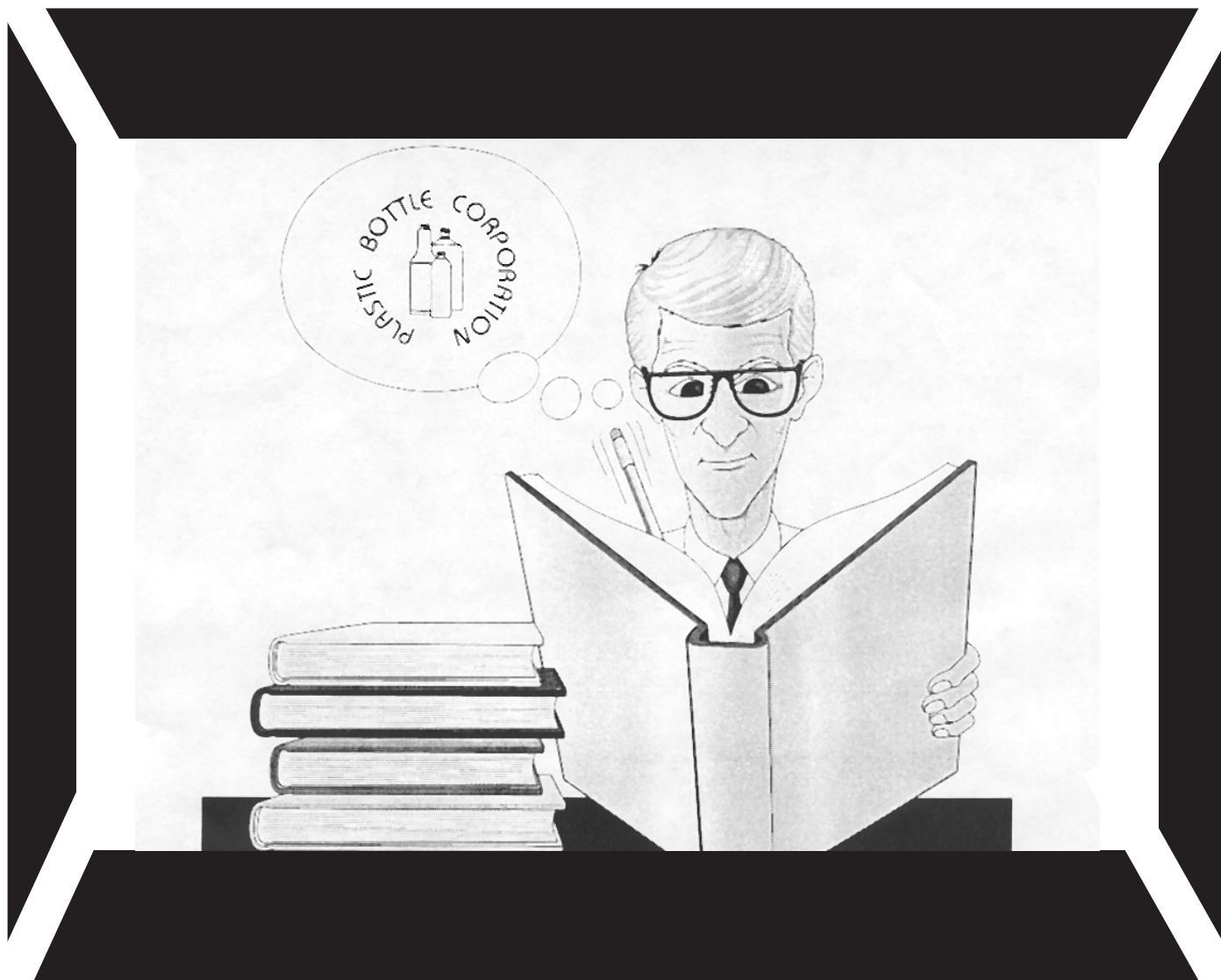

TECHNICAL INFORMATION

Where great ideas take shape.

S.P.I. NECK FINISH SPECIFICATIONS FOR STANDARD CLOSURES

MM	T		E		400H		410H		415H		S		I	THDS IN.
	MAX	MIN	MAX	MIN	MAX	MIN	MAX	MIN	MAX	MIN	MAX	MIN		
13	.514	.502	.454	.442					.467	.437	.052	.022	.218	12
15	.581	.569	.521	.509					.572	.542	.052	.022	.258	12
18	.704	.688	.620	.604	.386	.356	.538	.508	.632	.602	.052	.022	.325	8
20	.783	.767	.699	.683	.386	.356	.569	.539	.757	.727	.052	.022	.404	8
22	.862	.846	.778	.762	.386	.356	.600	.570	.852	.822	.052	.022	.483	8
24	.940	.924	.856	.840	.415	.385	.661	.631	.972	.942	.061	.031	.516	8
28	1.088	1.068	.994	.974	.415	.385	.723	.693	1.097	1.067	.061	.031	.614	6
30	1.127	1.107	1.033	1.013	.418	.388					.061	.031	.653	6
33	1.265	1.241	1.171	1.147	.418	.388			1.289	1.259	.061	.031	.791	6
35	1.364	1.340	1.270	1.246	.418	.388					.061	.031	.875	6
38	1.476	1.452	1.382	1.358	.418	.388					.061	.031	.987	6
40	1.580	1.550	1.486	1.456	.418	.388					.061	.031	1.091	6
43	1.654	1.624	1.560	1.530	.418	.388					.061	.031	1.165	6
45	1.740	1.710	1.646	1.616	.418	.388					.061	.031	1.251	6
48	1.870	1.840	1.776	1.746	.418	.388					.061	.031	1.381	6
51	1.968	1.933	1.874	1.839	.423	.393					.061	.031	1.479	6
53	2.067	2.032	1.973	1.938	.423	.393					.061	.031	1.578	6
58	2.224	2.189	2.130	2.095	.423	.393					.061	.031	1.735	6
60	2.342	2.307	2.248	2.213	.423	.393					.061	.031	1.853	6
63	2.461	2.426	2.367	2.332	.423	.393					.061	.031	1.972	6
66	2.579	2.544	2.485	2.450	.423	.393					.061	.031	2.090	6
70	2.736	2.701	2.642	2.607	.423	.393					.061	.031	2.247	6
75	2.913	2.878	2.819	2.784	.423	.393					.061	.031	2.424	6
77	3.035	3.000	2.941	2.906	.502	.472					.075	.045	2.546	6
83	3.268	3.233	3.148	3.113	.502	.472					.075	.045	2.753	5
89	3.511	3.476	3.391	3.356	.550	.520					.075	.045	2.918	5
100	3.937	3.902	3.817	3.782	.612	.582					.075	.045	3.344	5
110	4.331	4.296	4.211	4.176	.612	.582					.075	.045	3.737	5
120	4.724	4.689	4.604	4.569	.700	.670					.075	.045	4.131	5

“H” Dimension: The height of the neck finish. Measured from the top of the neck to the point where the diameter, “T”, extends down and intersects the shoulder.

“S” Dimension: Measured from the top of the finish to the top edge of the first thread. The “S” dimension is the key factor in determining the orientation of the closure to the bottle and the amount of thread engagement between the bottle and cap.

“I” Dimension: The inner diameter of the bottle neck. Specifications require a minimum “I” to allow sufficient clearance for filling tubes. Linerless closures, with a plug or land seal, and dispensing plugs and fitments require a controlled “I” for a proper fit.

“T” Dimension: The outside diameter of the thread. The tolerance of the “T” dimension determines the mate between bottle and closure.

“E” Dimension: The minor diameter measured across the root of the threads.

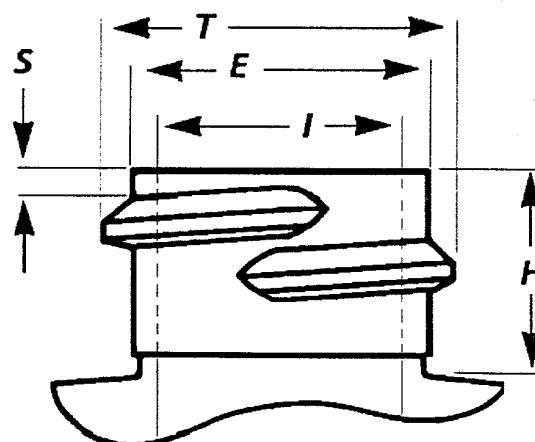

**PLASTIC BOTTLE
CORPORATION
847-367-1900
FAX 847-367-1990**

PLASTIC BOTTLE CORPORATION

28055 North Ashley Circle, Suite 110
Libertyville, IL 60048-9635
847-367-1900
Fax: 847-367-1990
www.plasticbottle.com

TORQUE GUIDELINES FOR CAPPING BOTTLES

Definition: Torque is a rotational force applied during application or removal of a closure from a bottle.

A. Application Torque: The rotational force with which a closure is applied to a bottle finish during capping. It affects seal integrity and tightness between bottle and closure. Properly established application torque will provide sealing integrity under expected conditions or temperatures, humidity and shock.

B. Removal Torque: The rotational force with which a threaded closure is removed or unscrewed from a bottle finish. It defines the amount of rotational force necessary to loosen, open, or remove the closure. A properly designed package should have a removal torque range appropriate for its intended use and the considered of any requirement for child resistant or tamper evident closure needs.

C. Stripping Torque: The application torque which is sufficient to cause the closure and/or bottle finish to distort and override the matching closure/bottle threads, resulting in loose caps, no seal, or package component deformation.

D. Torque Values: Torque is defined in inch-pounds or Newton-meters and is measured by various types of torque meters. Specific methods for performing torque tests are defined in Technical Bulletin PBI No. 7. The optimum relationship between applied and removal torques and good sealing characteristics under various physical and environmental conditions must be established for each individual package. Application torque requirements also vary according to the closure size being used.

The following torque values are listed *for use as guidelines only*, and are to be used for closure application by hand under controlled conditions. Special conditions may require torque values other than those listed.

<u>Neck Finish Identity</u>	<u>App. Torque (inch-pounds)</u>
8	3-7
10	4-8
13	5-9
15	5-9
18	7-10
20	8-12
22	9-14
24	10-18
28	12-21
30	13-23
33	15-25
38	17-26
43	17-27
48	19-30
53	21-36
58	23-40
63	25-43
66	26-45
70	28-50
83	32-60
86	40-65
89	40-70
100	45-70
110	45-70

Note: Immediate removal torque values are approximately 40-80% of hand application torque values. Production capping equipment should be adjusted to produce a similar immediate removal torque values.

*These are generally accepted application torques. Specific closures may require specific application torques which differ from those listed above.

Where great ideas take shape.

PLASTIC BOTTLE MATERIAL CODE SYSTEM SYMBOLS



PETE

1- PETE = Polyethylene Terephthalate



HDPE

2- HDPE = High Density Polyethylene



V

3- V = Vinyl/Polyvinyl Chloride



LDPE

4- LDPE = Low Density Polyethylene



PP

5- PP = Polypropylene



PS

6- PS = Polystyrene



OTHER

7- Other

PLASTIC BOTTLE CORPORATION

28055 North Ashley Circle, Suite 110
Libertyville, IL 60048-9635
847-367-1900
Fax: 847-367-1990
www.plasticbottle.com

FREIGHT CLASSIFICATIONS

$L \times W \times H \text{ (INCHES)} \div 1728 \text{ (CUBIC FEET)}$
 $LBS \div \text{CUBIC FEET} = \text{DENSITY (POUNDS PER CUBIC FEET AND/OR PCF)}$

EXAMPLE:
 $40'' \times 48'' \times 54'' = 103,680''$
 $103,680'' \div 1728 = 60 \text{ CUBIC FEET}$
 $300 \text{ LBS} \div 60 \text{ CUBIC FEET} = 5 \text{ POUNDS PER CUBIC FEET (PCF)}$
CLASS 150

PCF	CLASS
LESS THAN 1 _____	400
1 BUT LESS THAN 2 _____	300
2 BUT LESS THAN 4 _____	250
4 BUT LESS THAN 6 _____	150
6 BUT LESS THAN 8 _____	125
8 BUT LESS THAN 10 _____	100
10 BUT LESS THAN 12 _____	92.5
12 BUT LESS THAN 15 _____	85
15 OR GREATER _____	70

This is only a guide. Please contact your freight carrier for further information.

CLOSURES & CONTAINERS

Nov/Dec 1996 ■ Vol. III, No. 6

A LUCAS PUBLICATION

MAGAZINE

THE MARKET SHARE

PLASTIC CONTAINERS

AUTOMOTIVE ADDITIVES, OILS & LUBRICANTS

A Brief Case Study

by Stuart Feen, President and Melissa Thompson, Vice President
Plastic Bottle Corporation



"Not all chemicals are compatible with all type of plastics used in plastic bottles."

Packagers of automotive additives, specialty oils and a variety of lubricants know that it is not easy to successfully bring a product to the retail shelf. Extensive work must be done well before the products are packed into their various containers which, for the purposes of this discussion, are considered to be plastic bottles.

The first step in choosing the right plastic container should be testing for the chemical compatibility of the product or products to be packed in the chosen container or containers. Many type of chemicals, additive packages and oils are utilized to create an automotive additive, specialty oil or lubricant. Not all chemicals are compatible with all type of plastics used in plastic bottles. A number of chemicals are fairly aggressive in their reaction to various plastics used in plastic bottles. Aggressive chemicals such as xylene and toluene are so strong they can distort and soften some plastics to the point where what was once a rigid plastic bottle is now a fairly flexible plastic bag. Automotive additives are currently packaged in a variety of resins and/or compounds. These include, but are not limited to HDPE, PVC, P.E.T., and BAREX. The actual material to be used in the plastic bottle must be determined by thorough and complete testing.

The most popular compatibility test is to put actual product into the intended plastic bottle, close tightly and place the test samples in a laboratory oven at 120 degrees F for 30 or 35 days. The bottles should be checked daily for any changes in gram weight, color of bottle, odor on outside of the bottle indicating migration, and any other characteristics which are deemed important and appropriate to the particular product and testing protocol used by the

particular testing facility, which may be an in-house QC department or a professional testing laboratory. Many people believe that 30 or 35 days in the oven at 120 degrees F approximate 6 months on the store shelf. However, this is only an approximation and we caution all of our customers and prospects to carefully test for however long they feel is proper and necessary. A part of any testing procedure should also include drop tests, both bare bottles and bottles in the intended shipping carton. Also related to dropping of the bottles, we highly recommend that bottles should not be shipped by UPS or any other such form of single package delivery. If people do wish to ship by UPS or some other such delivery service, then they should seek the help of the particular delivery service in developing the proper shipping container. Filled product in plastic bottles is best shipped on pallets. We highly recommend to all of our customer that the shipper carton be designed to carry any and all required loads and protect the bottles from side loads and most especially top loads.

The responsibility for testing the product with container and for designing and testing shipper cartons rests solely with the purchaser of the bottles. We can offer a certain amount of help in all of the areas discussed above, but in the end it is the responsibility of the customer. No company should assume that their chemicals will be compatible with any plastic bottle, nor assume a product is compatible with a plastic bottle just because another company has a similar product on the shelf. Thorough testing, either a shelf test or an oven test, should be completed to assure long term shelf life of your product. C&C

THE BLOW MOLDING PROCESS

by Stuart Feen

*Blow molding dates back to at least 1890, when it was used to produce celluloid baby rattles. From that time forward, many companies have tried numerous means to produce blow molded parts in a variety of materials. The first polyethylene bottle was blown in December of 1942. The rest is history: the U.S. currently produces 30 to 40 billion plastic bottles per year, with the number constantly growing. For an excellent history of the plastics industry through 1972, those reading this article may wish to consult *Plastics History U.S.A.* by Harry Dubois, published by Cahners Books, Boston, Mass., ISBN 0-8436-1203-7.*

continued...

...continued from page 29

There are basically four types of blow molding used in the production of plastic bottles, jugs and jars. These four types are: extrusion blow molding, injection blow molding, stretch blow molding and reheat and blow molding. Extrusion blow molding is perhaps the simplest type of blow molding, whereby a hot tube of plastic material is dropped from an extruder and captured in a water cooled mold. Once the molds are closed, air is injected through the top or the neck of the container; just as if one were blowing up a balloon. When the hot plastic material is blown up and touches the walls of the mold the material "freezes" and the container now maintains its rigid shape. There are various types of shuttle, reciprocating and wheel style machines for the production of extrusion blown bottles. Shuttle or reciprocating type machines can be used for small, medium and high volume production with wheel machines being the most efficient for huge volume production of certain resins.

Injection blow molding is part injection molding and part blow molding. With injection blow molding, the hot plastic material is first injected into a cavity where it encircles the blow stem, which is used to create the neck and establish the gram weight. The injected material is then carried to the next station on the machine, where it is blown up into the finished container as in the extrusion blow molding process above.

Injection blow molding is generally suitable for smaller containers and absolutely no handleware. Extrusion blow molding allows for a wide variety of container shapes, sizes and neck openings, as well as the production of handleware. Extrusion blown containers can also have their gram weights adjusted through an extremely wide range, whereas injection blown containers usually have a set gram weight which cannot be changed unless a whole new set of blow stems are built. Extrusion blow molds are generally much less expensive than injection blow molds and can be produced in a much shorter period of time.

Many people have heard about stretch blow molding in conjunction with P.E.T. bottles commonly used for water, juice and a variety of other products. There are two processes for stretch blow molded P.E.T. containers. In one process, the machinery involved injection molds a preform, which is

then transferred within the machine to another station where it is blown and then ejected from the machine. This type of machinery is generally called injection stretch blow molding (ISBM) and usually requires large runs to justify the very large expense for the injection molds to create the preform and then the blow molds to finish the blowing of the container. This process is used for extremely high volume (multi-million) runs of items such as wide mouth peanut butter jars, narrow mouth water bottles, liquor bottles etc.



Another stretch blow process is commonly called reheat and blow (RHB). In this process, a preform is injection molded by an outside vendor. There are a number of companies who produce these

"stock" preforms on a commercial basis. Factories buy the preforms and put them into a relatively simple machine which reheats it so that it can be blown. The value of this process is primarily that the blowing company does not have to purchase the injection molding equipment to blow a particular container, so long as a preform is available from a stock preform manufacturer. This process also allows access to a large catalog of existing preforms. Therefore, the major expense is now for the blow molds, which are much less expensive than the injection molds required for preforms.



There are, however, some drawbacks to this process. If you are unable to find a stock preform which will blow the container you want, you must either purchase injection molds and have your own private mold preforms injection molded, or you will have to forego this process. For either type of stretch blow molding, handleware

is not a possibility at this stage of development. The stretch blow molding process does offer the ability to produce fairly lightweight containers with very high impact resistance and, in some cases, superior chemical resistance.

Whether using the injection stretch blow molding process or the reheat and blow process, an important part of the process is the mechanical stretching of the preform during the molding process. The preform is stretched with a "stretch rod." This stretching helps to increase the impact

...continued on page 31

...continued from page 30

resistance of the container and also helps to produce a very thin walled container.

The extrusion blow molding process allows for the production of bottles in a wide variety of materials, including but not limited to: HDPE, LDPE, PP, PVC, BAREX®, P.E.T., K Resin, P.E.T.G., and Polycarbonate. As noted above, a wide variety of shapes (including handleware), sizes and necks are available. Injection blow molding allows for the production of bottles in a variety of materials, including but not limited to: HDPE, LDPE, PP, PVC, BAREX®, P.E.T., and Polycarbonate.

Besides the P.E.T. noted above for stretch blow molding, a number of other materials have been stretch blown, including polypropylene. As time goes on and technology moves forward, more materials will lend themselves to stretch blow molding as their molecular structures are altered to suit this process.

The decision as to which process will be used is based upon the desired appearance (clear or not), whether chemical or impact resistant is desired, and the desired cost/bene-

fit relationship. The ultimate choice of materials and processes is also based upon the cost of the tooling involved and the sizes of the production runs. Some materials lend themselves to certain types of decorating better than others and some to certain types of decorating to the exclusion of others.



Listed below are representative brands of some types of the machinery we have discussed above. This list is not all-inclusive and you will find additional brands by looking through this and other packaging industry journals and magazines.

For shuttle extrusion type machines Bekum, Battenfeld/Fischer, and Hayssen are probably the best known in the United States. For injection blow molding machines JOMAR is a well known brand. For stretch blow and reheat and blow type machines there are Sidel,

Nissei and other machines produced by Johnson Controls and others. For wheel machines you might wish to contact Johnson Controls or Wilmington Machinery. *C&C*
Special thanks to Nissei for the photographs.

When it comes to plastic bottles... THINK PINK!



Order you FREE Plastic Bottle Corporation catalog today! Our catalog puts the power to succeed at your fingertips. We offer a variety of stock, custom and customized plastic bottles, jugs and jars ranging in size from 3/4 oz. to 192 oz. produced in HDPE, LDPE, PP, , OPET, EPET and PCR HDPE.

We're always building something new for you and your customers. Please contact us for samples, quotations, or new designs and for your free catalog!

CALL TOLL-FREE 1-888-PBC-PINK

PLASTIC BOTTLE CORPORATION...Where great ideas take shape.

Toll-Free: 888-PBC-PINK • Fax: 847-367-1990 • sales@plasticbottle.com • 28055 North Ashley Circle Suite 110 • Libertyville, IL 60048-9635

PLASTIC BOTTLE CORPORATION

28055 North Ashley Circle, Suite TTU
Libertyville, IL 60048-9635
847-367-1900
Fax: 847-367-1990
www.plasticbottle.com

THE NECESSITY OF OBTAINING CLOSURE SAMPLES AND INFORMATION PRIOR TO A PLASTIC BOTTLE PRODUCTION RUN

By Stuart Feen, President, Plastic Bottle Corporation

Virtually all manufactured parts have a plus or minus (+/-) range of dimensional acceptability (tolerances), and plastic bottles and closures are no different, except that their ranges may be greater than some types of products and less than some other types. Because closures and bottle necks represent a variety of manufacturing variabilities and tolerances, even if they are within specifications, which can affect mating possibilities of one to the other, we always need to know what closures, sprayers or finger tip sprayers/pumps are to be used on our bottles. When we receive the order, we ask for the closure, sprayer, or finger tip sprayer/pump manufacturer's specifications and ask for samples of the closure, sprayer or pump to be used on our bottle.

Definitions and Discussion

*****CT** means a regular screw cap with a continuous thread. This is the most common type of cap or closure, having smooth or ribbed sides (skirts) and a rough or smooth top. They come in virtually any color and are commonly designated as 400, 410, and 415, as in, 24-415. This type of closure is usually lined with a paper, plastic, foil, film or combination liner in order to provide the best sealing of the product within the bottle for product integrity and to avoid leakage in shipment. The Plastic Bottle Institute, a division of The Society of the Plastics Industry, Inc., has published Dimensions and Tolerances for Plastic Bottles for a number of years and these dimensions and tolerances cover most of the 400, 410, and 415 standard necks plus some others. For a variety of reasons there should never be an assumption of what is standard without all parties of and suppliers to the transaction being aware of what the other's dimensions and tolerances are.

*****CRC** means a Child Resistant Closure which may be of a single piece or two piece design. If a two piece CRC, it usually has a CT inner cap with the palm or push down and turn outer shell. There is also a two piece pull up and turn CRC. CRCs usually have special "H" requirements that are not standard 400 or 410, even though they may be designated as 28-400 or 24-410 etc. The two piece push down style especially requires careful attention to the "H", since even if the neck is too short the closure can usually be applied to the neck. But when the end user tries to push down to take the closure off of the bottle, the closure bottoms out on the bottle shoulder and the outer shell cannot properly engage the inner cap, leaving the consumer with a very well sealed bottle that they cannot open. This is not a good situation.

***An **ORIFICE REDUCER** is an injection molded piece that fits into the neck of the bottle to reduce the size of the opening from a river to a very small streamlet. Each neck I.D. (inside diameter) must be carefully set and maintained for each type, style, and size of orifice reducer to be used. Because of the tremendous possible variety there is no such thing as a standard I.D.

***A **LINED** closure is one that has a paper, plastic, metal foil, film or combination liner. Dispensing closures are sometimes lined and other types of usually unlined closures are sometimes lined for various reasons.

***A **LINERLESS** non-dispensing closure is usually a closure that has been designed to be used without a liner because it has some sort of anti-leaking feature molded into the inside top of the cap. A crabs claw is such a feature.

Where great ideas take shape.

LINERLESS closures were first developed as a way to reduce the closure cost by not having the dual expenses of the liner material and the application of the liner. LINERLESS closures represent a greater possibility for leaking than lined closures. Even though we are regularly measuring the necks during manufacture, there may be certain anomalies that, while they might be picked up with visual and physical inspection, might show up faster and easier with actual checking the specific closure on the specific bottle.

***An **UNLINED** CT closure is sometimes one that was designed to be used with a liner, but which, for whatever reason, does not have a liner. This is a very risky situation, especially for leakage of liquid products and is not, except for very special situations, acceptable.

*****DISPENSING** closures are those that via a pull/push, spout, twist, or flip top allow products to be dispensed. Dispensing closures are usually linerless closures with some sort of sealing mechanism such as: crabs claw, valve seal, land seal or some combination of the seals, but not always. The land is the surface at the top of the neck. The land seal is riskiest from a leaking point of view and we absolutely must have cap samples for testing with the bottle necks when we run the bottles. Some dispensing closures have a "valve", which is a partial cone that fits into the neck of the bottle and seals against the inside of the neck. Here, and with the valve/land seal as well, we must have the closure manufacturers' neck I.D. specifications and tolerances and lots of samples for testing while running. The valve seal/land seal combination is the least risky, but there is still risk.

*****TRIGGER SPRAYERS, FINGER TIP SPRAYERS, ANTI-ROTATIONAL or RATCHET CAP SPRAYERS OR DISPENSING CLOSURES** represent special actual and potential problems and need to be looked at individually with reference to all applicable manufacturer's specifications.

When taking any order we first need to ask what closure is to be used with the bottle. We need to know the closure size and manufacturer. If the closure is a regular, non-dispensing 400, 410, or 415 size with a non-induction seal or pressure sensitive liner, then we might be o.k. without getting samples from the customer as long as we get all of the dimensional specs. However, to be entirely safe we should still ask for samples of these least problematic of closures for testing.

For any other closure, pump, or sprayer we need to have 200 samples for testing bottles while we run, and we also need to have the specified NECK FINISH print for that closure. We should also have the closure print, but we absolutely must have the print or printed numerical specifications for the neck finish. We need to know, among other things the REQUIRED:

- * "H"
- * "S"
- * "T"
- * "E"
- * I.D. lead-in radius
- * Min land thickness
- * Any other neck specs the closure manufacturer wishes to call out

If the closure has an induction seal or pressure sensitive liner, then we **MUST** be certain to obtain from the closure manufacturer the **MINIMUM LAND** their closure requires for use with induction seal or pressure sensitive liners. This will in turn define the I.D.

Lastly, while talking about the neck, it is always nice to know the diameter of the customer's fill tubes. The buyer or purchasing agent may not know this, so it is especially important to ask them if they have checked the samples we sent to them on their filling lines and especially with their fill tubes. An I.D. that is consistent with all of the above requirements is then specified on orders for that customer for that bottle with the particular closure.

PLASTIC BOTTLE CORPORATION

Properties of Resins

Resins	Polyester	Polyester	Polyvinyl Chloride	Polyethylene	Polypropylene
Properties	PET	PETG	PVC	HDPE	LDPE
Clarity	Clear	Clear	Clear	Opaque	Translucent
Rigidity/Stiffness	Moderate to High	Moderate to High	Moderate to High	Moderate	Moderate to High
Impact Resistance	Good to Excellent	Good	Fair to Good	Good to Excellent	Excellent
Low Temp. Impact Resistance	Fair to Good	Poor	Poor to Fair	Good to Excellent	Excellent
Stress Crack Resistance	Good to Excellent	Good	Good to Excellent	Good to Excellent	Good
Moisture Barrier	Fair to Good	Fair to Good	Fair	Good to Excellent	Good
Oxygen Barrier	Good	Good	Good	Poor	Poor
Scuff Resistance	Poor to Fair	Poor to Fair	Poor to Fair	Very Good	Very Poor
Resistance To:					
Acids	Fair to Good	Fair to Good	Good to Excellent	Fair to Very Good	Fair to Very Good
Alcohols	Good	Good	Good to Very Good	Good	Good
Alkalis	Poor to Fair	Poor to Fair	Good to Very Good	Good to Very Good	Good to Very Good
Mineral Oils	Good	Good	Good	Fair	Poor to Fair
Solvents	Good	Good	Fair to Good	Poor to Fair	Poor to Fair
Heat	Poor to Fair	Poor to Fair	Poor to Fair	Good	Fair
Cold	Good	Good	Fair	Excellent	Excellent
Sunlight	Good	Good	Poor to Good	Fair	Fair

**This information is supplied for use as a guideline only. Information may vary under certain conditions.
It is the responsibility of the customer to make compatibility tests with each product application.**

TERMS AND CONDITIONS OF SALE

1. Used herein, "Seller" means Plastic Bottle Corporation; "Products", the goods and items sold by Seller hereunder; "Purchaser", all buyers and users of Products produced and sold hereunder. Seller's sole responsibility is to furnish Products in accordance with specifications furnished Seller by Purchaser. SELLER IS NOT RESPONSIBLE FOR COMPLETENESS, CORRECTNESS, SUITABILITY, APPROPRIATENESS, OR OTHERWISE OF PURCHASER'S SPECIFICATION. PURCHASER HAS NOT INFORMED SELLER OF THE INTENDED USE OF PRODUCTS, AND IN ANY EVENT SELLER SHALL NOT BE RESPONSIBLE FOR SUITABILITY FOR, OR PROPRIETY OF, ANY PARTICULAR OR SPECIFIED INTENDED USE OF PRODUCTS. PURCHASER'S SOLE AND EXCLUSIVE REMEDY WITH RESPECT TO THIS AGREEMENT AND PRODUCTS SHALL BE TO OBTAIN REPAIR OR REPLACEMENT OF NON- CONFORMING PRODUCTS, UNLESS OTHERWISE AUTHORIZED IN WRITING BY SELLER. IN NO EVENT SHALL SELLER BE LIABLE FOR ANY INCIDENTAL, INDIRECT, OR CONSEQUENTIAL DAMAGES WHATSOEVER, INCLUDING (BUT NOT LIMITED TO) LOST PROFITS ARISING OUT OF OR RELATED TO THE PRODUCTS OR SERVICES PROVIDED HEREUNDER BY SELLER, EVEN THOUGH SELLER MAY HAVE BEEN ADVISED, KNOWN OR SHOULD HAVE KNOWN OF THE POSSIBILITY OF SUCH DAMAGES. Transportation charges for all returned goods shall be the responsibility of Purchaser, unless expressly agreed to the contrary in writing by Seller.

2. SELLER RESERVES THE RIGHT AT ANY TIME AFTER THE ACCEPTANCE OF AN ORDER TO CANCEL SAME, WITHOUT LIABILITY, IN THE EVENT THAT IN SELLER'S JUDGMENT, PURCHASER'S INTENDED USE OF THE GOODS MAY RESULT IN DEATH OR INJURY TO PERSONS OR PROPERTY ATTRIBUTABLE TO INCOMPATIBILITY BETWEEN THE GOODS AND PURCHASER'S PRODUCT.

3. SELLER MAKES NO REPRESENTATIONS OR WARRANTIES OTHER THAN AS STATED IN THESE TERMS AND CONDITIONS. THERE ARE NO WARRANTIES WHICH EXTEND BEYOND THESE "TERMS AND CONDITIONS". ALL OTHER EXPRESS OR IMPLIED WARRANTIES ARE HEREBY EXCLUDED, INCLUDING (BUT NOT LIMITED TO) IMPLIED WARRANTIES OF NON-INFRINGEMENT, MERCHANTABILITY AND FITNESS FOR PURPOSE.

Seller has no knowledge of Purchaser's intended use, but has provided Products based solely upon information furnished by Purchaser. Seller makes no representations or warranties to Purchaser regarding any infringement of intellectual property rights (or the absence thereof) by Products. Seller reserves all intellectual property rights it may have in the Products. All intellectual property rights with respect to any design and/or invention conceived or first reduced to practice by Seller in connection with the Products shall reside in Seller.

4. Unless expressly stated in writing to the contrary, Seller reserves the right to select its source of raw materials, suppliers or producers of the Purchaser's goods. Seller shall not be liable for any delays or failures in delivery due to causes beyond its control, including (but not limited to) strikes, fires, floods, storms, scarcity of materials, government regulations/orders, or acts of God. Overruns or underruns, not to exceed 10o/o of the amount ordered, shall be considered acceptable delivery. The excess or deficiency shall be charged proportionately.

5. Unless explicit shipping instructions have been given Seller by Purchaser, Seller shall use its best judgment in shipping goods to Purchaser. In the event that pallets or containers owned by Seller are shipped with goods, Seller may make a reasonable deposit charge, to be refunded or credited upon the return of such pallets or containers in good condition, ordinary wear and tear excepted. In the event that Purchaser has given Seller specific shipping instructions, Seller will comply with those instructions to the extent practicable; provided, however, that Seller assumes no liability for failure to comply. Seller reserves the right to (a) invoice Purchaser for and/or to ship, any products at any time on or after date of manufacture or Purchaser's initial requested shipping date as shown on the face hereof, whichever is the later; (b) transfer to its general stock any products ordered by Purchaser for which Seller shall have been given no instructions for shipment to be made within four (4) weeks following the date of manufacture or Purchaser's initial requested shipping date, whichever is the later; or (c) resell for any prices and on any terms Seller may choose, or to scrap, any products for which Purchaser shall not have requested that shipment be made within six (6) months following Purchaser's initial requested shipping date or date of manufacture, whichever date shall last occur, and to invoice Purchaser for such products according to Seller's then current price list less net proceeds from any resale of any net scrap value. Seller reserves the right to assess storage charges on all merchandise held in storage by Seller in excess of thirty (30) days following completion of the order or thirty (30) days after the Purchaser's requested availability date, whichever is the later. Except as stated herein to the contrary, no merchandise may be returned without the written authorization of Seller, and Seller reserves the right to impose a reasonable restocking charge for merchandise which Seller accepts for return when not otherwise required to do so. Seller recognizes no claim for damage to merchandise in transit, or shortages occurring during transit, unless noted by Purchaser on the delivery receipt at time of delivery and returned to Seller within five (5) days after delivery. Nothing herein shall be construed to require Seller to replace damaged goods or to make up shortages when such would not otherwise be its responsibility.

6. In the event of any breach of the provisions of this contract by Purchaser, Seller, at its option without prejudice to any other remedy or remedies which Seller may have against Purchaser for such breach, may (a) without affecting in any way the obligation of either party in respect of further shipments hereunder, regard each shipment as a separate and independent sale on the terms and conditions applicable hereunder; or (b) terminate this contract as regards further shipments and declare the obligations of Purchaser for all shipment made due forthwith, but Purchaser shall remain liable to Seller for all loss and damage sustained by reason of any such breach. Seller's right to require performance of Purchaser's obligations hereunder shall not be affected in any way by any previous waiver, forbearance or course of dealing.

7. Purchaser hereby agrees to be liable to Seller and any assignee of Seller for, and indemnifies and saves Seller and such assignee harmless from and against all claims, liabilities, judgments, decrees, fines, penalties, fees, amounts paid by or due from Seller or such assignee in settlement of, or any other costs, losses, or expenses incurred (including, but not limited to, attorney's fees, expert witness fees, court costs and expenses) directly or indirectly arising out of, resulting from or in association with, any threatened or pending claim, action, or suit (whether civil, criminal, administrative, investigatory or otherwise and whether valid or not) and any appeals related thereto, in or under which Seller is a party of participant; (a) because of any alleged or actual infringement by any of the Products of any intellectual property right; (b) because of Purchaser's use or misuse of Products; or (c) because of any other reason, including Purchaser's actual or threatened breach of, or default under, any of Purchaser's representations, warranties or obligations hereunder, or incurred by Seller to enforce any term or condition hereunder, or any of Purchaser's representations, warranties or obligations hereunder. Purchaser irrevocably agrees to pay Seller all costs and expenses including, without limitation, reasonable attorney's fees, court costs and the fees of collection agencies, incurred by the Seller in exercising any of its rights or remedies related to or under this agreement, enforcing any of the terms and conditions of this agreement or collecting any sums due Seller under this agreement.

8. Quoted prices are based upon immediate cash payment by Customer, unless expressly stated to the contrary on the face hereof. Seller shall be entitled to and Customer hereby agrees to and authorizes Seller, to charge additional fee for non-cash payments.

9. Prices quoted are for single shipments of the quantities of Products specified, unless otherwise authorized in writing by Seller. Prices quoted are subject to change without notice to Purchaser. Prices invoiced are those in effect at time of shipment, unless otherwise stated. Purchaser acknowledges that the prices reflect, and are based upon Purchaser's acceptance of, all terms of this agreement including, but not limited to, Paragraphs 1-8 hereof. Seller has indicated willingness to undertake greater liabilities and risk in exchange for increased charges reflecting that exposure. Purchaser has opted to accept lower charges and concomitant limitations on Seller's liabilities and risk as set forth herein. ALL SHIPMENTS ARE F.O.B.: PLANT OF MANUFACTURE OR WAREHOUSE. ON ALL SHIPMENTS, WHETHER OR NOT SELLER PAYS THE FREIGHT, TITLE AND RISK OF LOSS PASS TO PURCHASER AT TIME OF SHIPMENT FROM PLANT OF MANUFACTURE OR WAREHOUSE.

10. Terms inconsistent with those stated in these Terms and Conditions of Sale which may appear on Purchaser's order will not be binding on Seller unless otherwise authorized in writing by Seller. Terms and Conditions of Sale represents the entire Agreement between Seller and Purchaser regarding the subject matter hereof, and supersedes all prior written and oral agreements, representations and/or understanding between Seller and Purchaser regarding the subject matter hereof. Seller and Purchaser acknowledge and agree that there are no other written or oral agreements, promises, representations and/or understandings with respect to the subject matter hereof. Other than President of Seller or such other individual as he may nominate in writing, no employee, independent contractor, agent, or other representative of Seller shall have any power or authority to add to, waive, modify, alter or amend the Terms and Conditions of Sale and no amendments to or modifications of these Terms and Conditions of Sale will be valid and binding upon Seller unless in writing and signed by Seller. Any waiver by Seller of a breach of any provision of these Terms and Conditions of Sale shall not operate as or be construed to be a waiver of any other breach of such provision or of any other provision of these Terms and Conditions of Sale. The failure of Seller to enforce any term or condition of these Terms and Conditions of Sale on one or more occasion shall not be considered a waiver or deprive Seller of the right thereafter to enforce that term or any other term of the Terms and Conditions of Sale. No waiver by Seller of any default or breach by Purchaser shall be effective unless in writing and signed by Seller. The interpretation of these Terms and Conditions of Sale shall be governed by established trade customs.

11. This Agreement shall bind and inure to the benefit of the parties, their successors and assigns. THE AGREEMENT SHALL BE CONSTRUED UNDER THE INTERNAL LAWS OF THE STATE OF ILLINOIS and may be enforced by Seller in any state or federal court sitting in the State of Illinois. The parties hereby consent to the jurisdiction of the Illinois courts in any matter relating to this Agreement. The illegality, invalidity or unenforceability of any provision of the Agreement under the law of any jurisdiction shall not affect its legality, validity or enforceability under the law of any other jurisdiction, nor the legality, validity or enforceability of any other provision. Anything herein to the contrary notwithstanding, this contract is not assignable by Purchaser, except with the written consent of Seller, and the same shall terminate at the option of Seller in the event of any voluntary or involuntary bankruptcy, receivership, insolvency, or reorganization proceedings of, by or against Purchaser, but without thereby waiving any claim for damages which Seller may have against Purchaser.