

INDUSTRIAL WASTEWATER: TECHNOLOGY OVERVIEW

Marty Hanka, PE

Indiana Class D Operator

Hanka Associates, LLC

Lanesville, Indiana

812-786-0688

mjhanka@aol.com

DISSOLVED AIR FLOATATION

- Cross Flow Plate Pack Design (Lamella style)
- Open Tank Design



Industrial Sectors

- Food industry
 - Primary poultry, pork, and beef processing
 - Secondary meat processing
 - Vegetable processing
 - Dairy
 - Vegetable oils refinery & processing
 - Fish
 - Convenience food
 - Confectionary/Bakery
 - Pet Food

Industrial Sectors

- Oil & Gas
 - Refineries
 - Petrochemical & Chemical
- Others
 - Pharmaceutical
 - Remediation
 - Municipal
 - Pulp & Paper/Textile
 - Metal Industry

Process Calculations

Hydraulic Surface Loading

The design **hydraulic surface loading rate** should be $<$ rising velocity of solids defined according to **Stokes Law** $V_r = \frac{d(\rho) * g * d^2}{18 \eta}$ otherwise the solids will not be separated.

Hydraulic Surface loading rate is defined as

$$\frac{\text{flow-rate in gpm defined as FEED + recycle flowrate}}{\text{effective separation surface area in sqft}}$$

The effective surface area is defined as the projected installed area of the plate pack. Hydraulic surface loading rates can vary between $\frac{1}{2}$ and 4 **gpm/sqft/hr. Increased hydraulic surface loading rates will result in solids ‘carry over’ and reduced turbidity and removal rates.**

Process Calculations

Solids Loading Calculations

Defined as maximum **Solids loading** handling capacity in lb/sqft/hr of the separator. The design solids loading rate should be > than maximum amount of solids to be separated

The solids loading rate is defined as

$$\frac{\text{Weight of TSS in feed to DAF in lb/hr}}{\text{free surface area in ft}^2}$$

The weight of the TSS is defined as TSS of FEED + the precipitated colloidal matter present in the Feed (if coagulants and flocculants are used) + the hydroxides formed by metal salt addition. In general calculations will be based on COD.

Maximum solids loading rate numbers can vary from 2 ½ to 15 **lb/sqft/hr** depending on application.

Increased SS loading beyond the design loading rate will result in reduced SS removal efficiency of DAF.



Process Calculations

Solids Loading Calculations

Aeration system

Air to solids ratio is defined as volume of air required for the separation at STP.

The air to solids ratio is defined as

$$\frac{\text{Liters of air at STP in liters/hr}}{\text{Total amount of solids to be separated in kg/hr}}$$

The air to solids ratio use is 6 liters/kg to 10 **liters/kg**

Dissolved Air Flotation Unit With Flocculator

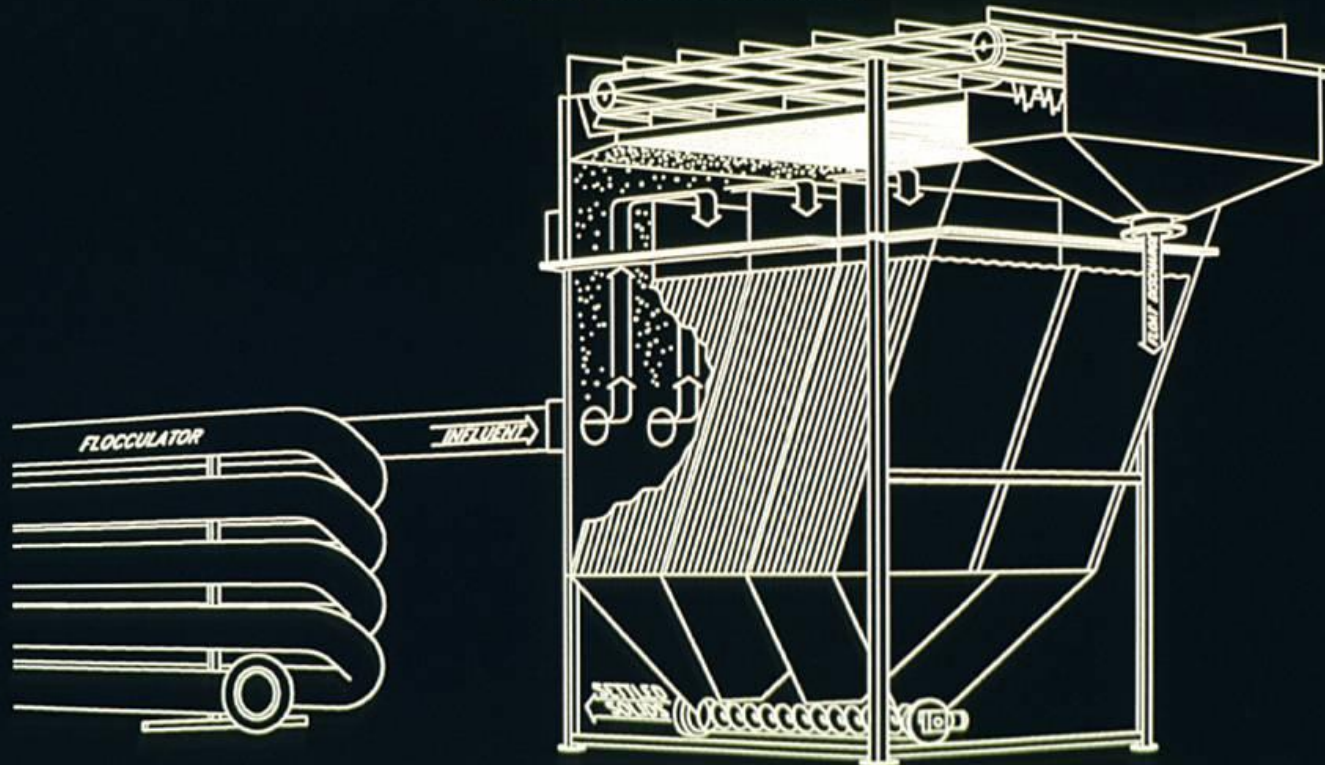

Separation Process

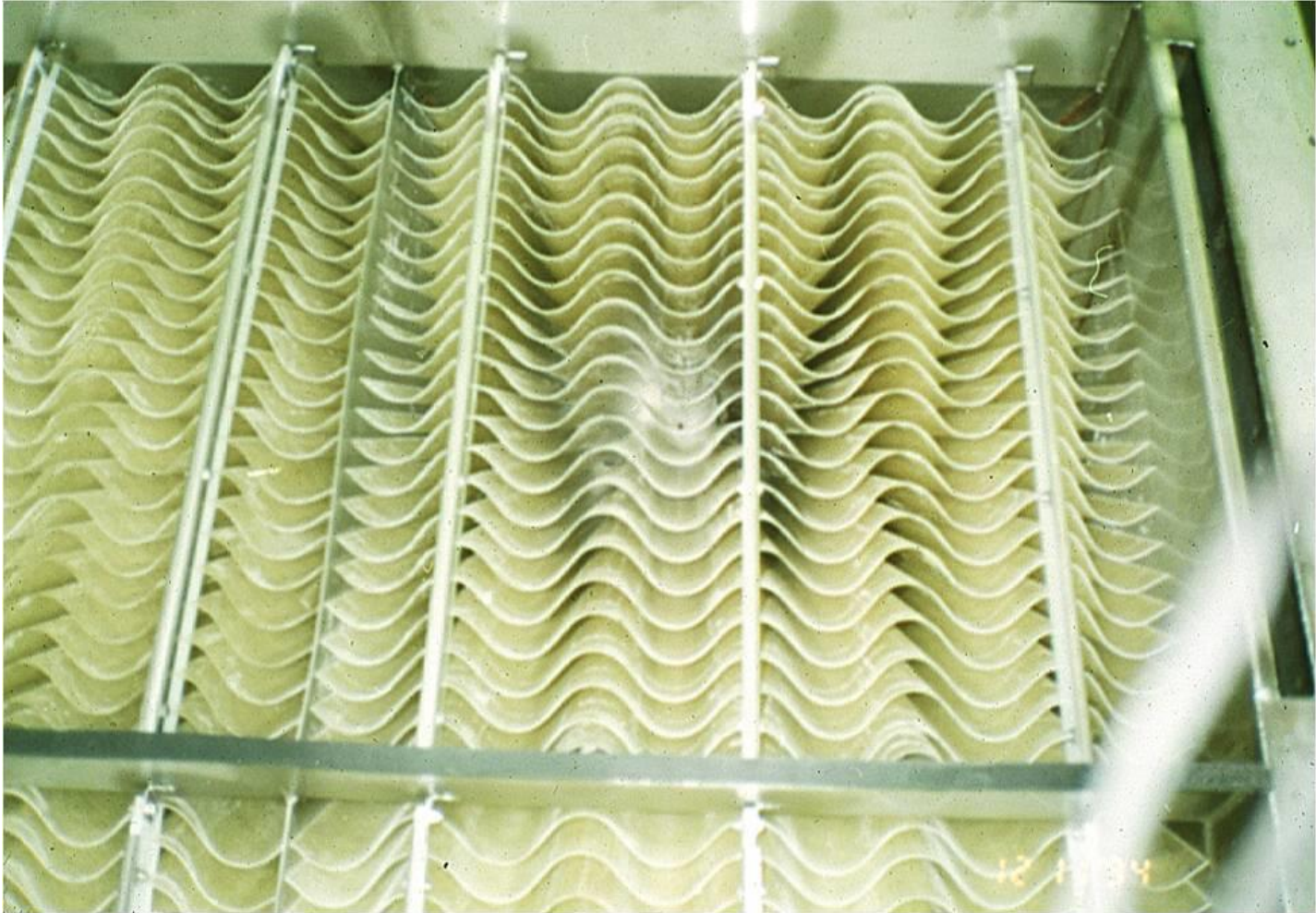

Chemical Feed System

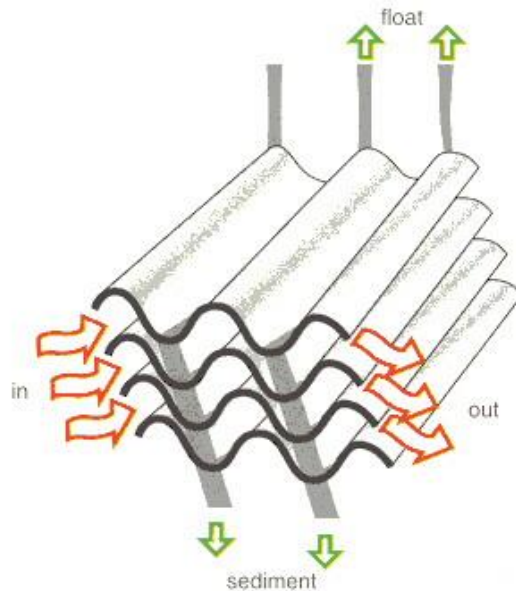

Plate Pack

DAF – PCL series

Cross Flow Plate Pack design

Cross-flow



'Counter current

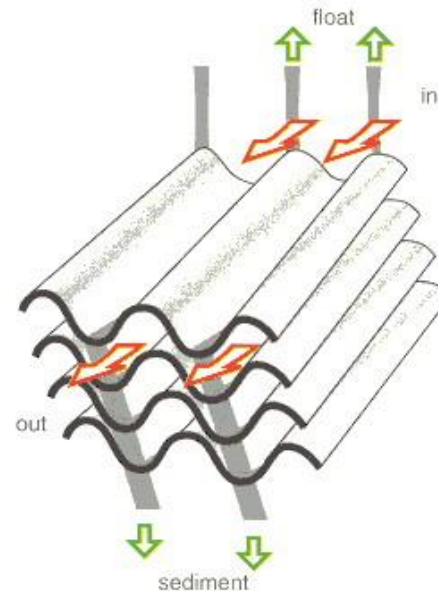

Duplex ANSI Recycle Pumps



Air Dissolving Tube



Dewatering Grid Principle



Dewatering Grid Principle

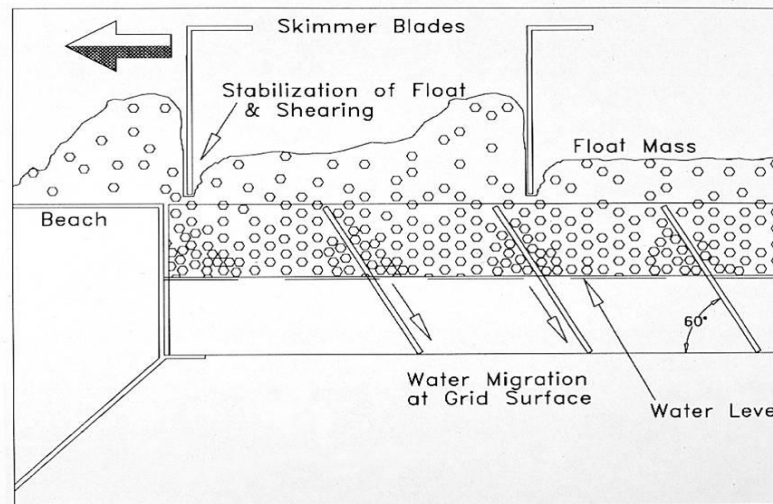
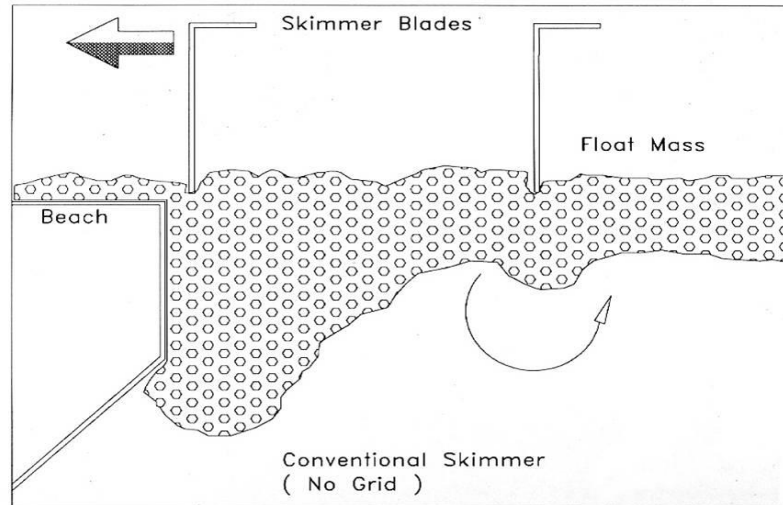

Condiment Plant



Poultry Plant



Soap Plant



Soap Plant

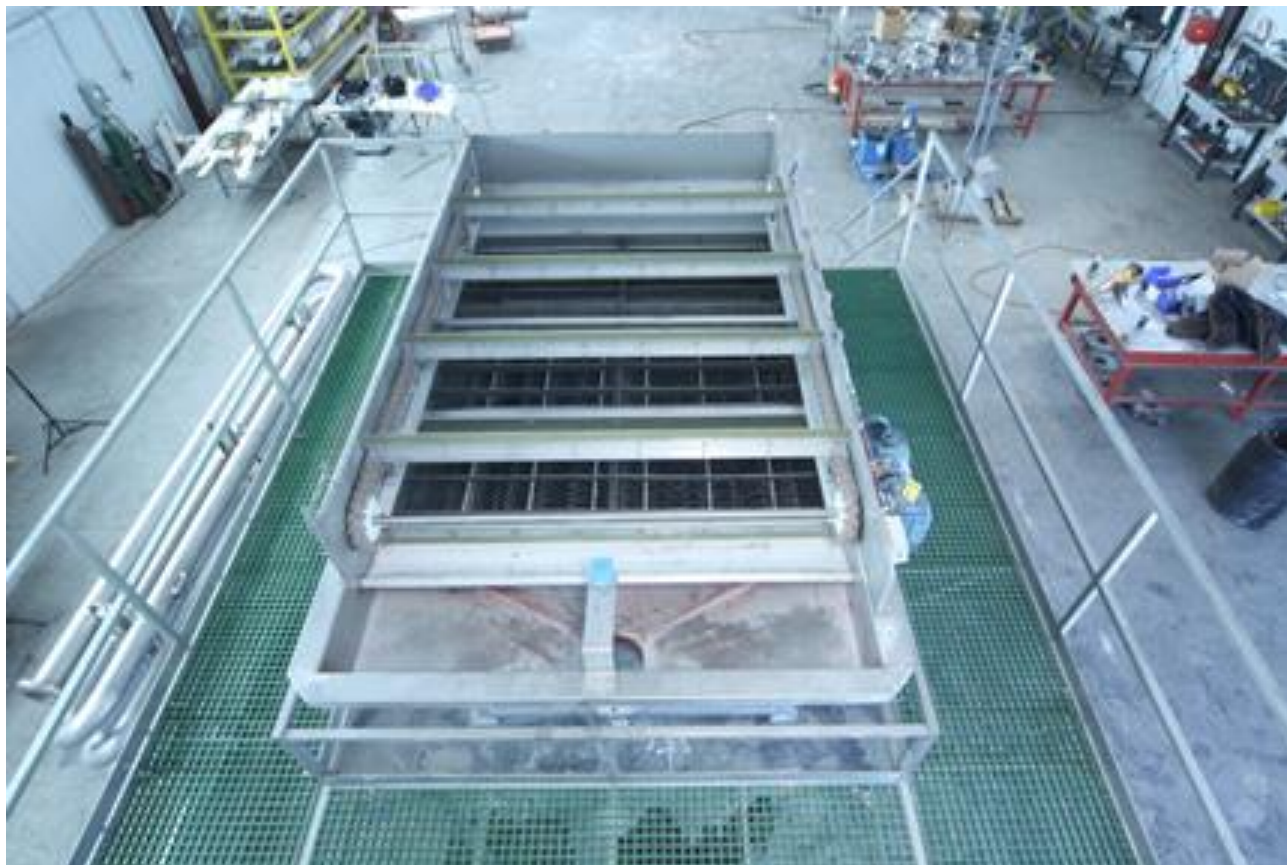

Pet Food Plant



Dairy Plant



Rotary Screen



SOLIDS AUGER





FOOD WASTE



HIGH CAPTURE RATE



BREWERY - SPENT HOPS



DEWATERED 15-25% SOLIDS



Oil / Water Separators

M MERCER INTERNATIONAL, INC. *Oil/Water/Solids Separators*



U.S. Patented, Pat. Nos. 5,173,195 & B1 5,173,195

© 2002 Mercer International, Inc. All rights reserved.

Oil / Water Separators

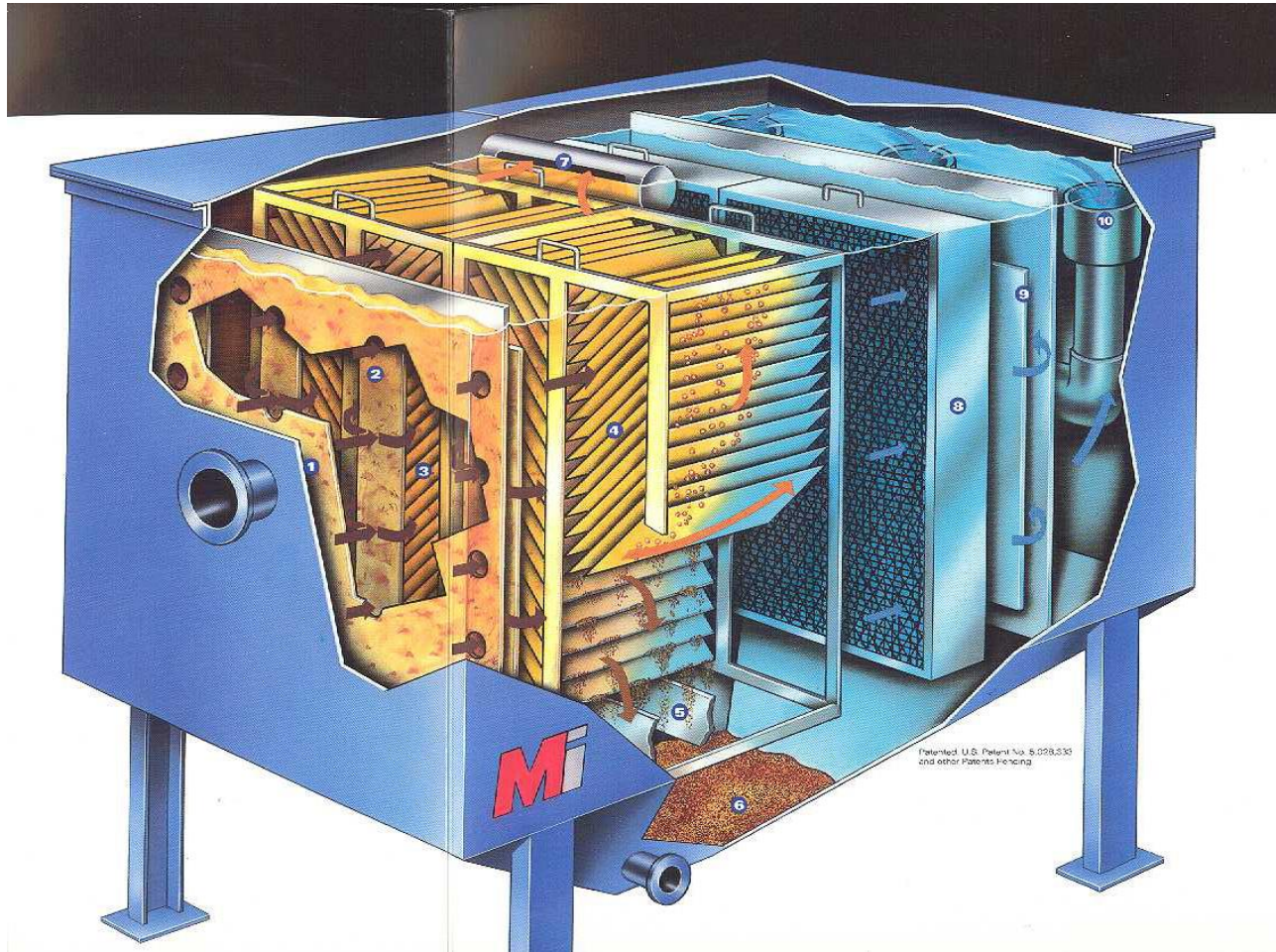

Oil / Water Separators

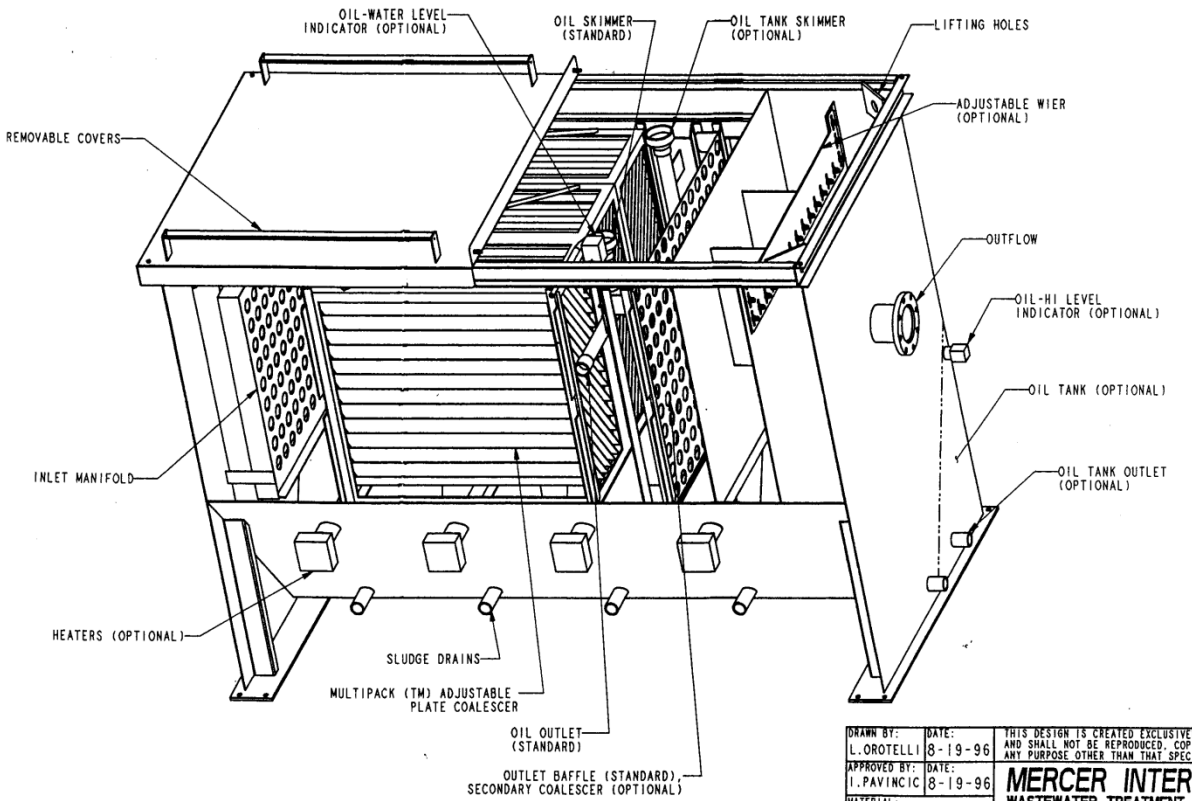

U.S. PATENTED
#5,028,333; 5,173,195
& OTHER PATENTS PENDING

| | | | | |
|--|--------------------------|--------------------------|---|--|
| DRAWN BY: L. OROTELLI | | DATE: 8-19-96 | | THIS DESIGN IS CREATED EXCLUSIVELY FOR MERCER INTERNATIONAL AND SHALL NOT BE REPRODUCED, COPIED IN ANY WAY, OR USE ANY PURPOSE OTHER THAN THAT SPECIFIED BY M.I. |
| APPROVED BY: I. PAVINCIC | | DATE: 8-19-96 | | |
| MATERIAL: NOTED IN DWG. NO. AL: 3003-H14 ALUM SS: STAINLESS 304 CS: CARBON STEEL | | | | MERCER INTERNATIONAL WASTEWATER TREATMENT SYSTEMS MENDHAM, NEW JERSEY TITLE: OIL/WATER/SOLIDS SEPARATOR |
| SCALE: | MODEL NAME: SEPARATOR | DRAWING NUMBER: 10120 | 1 | |

Metals Precipitation



Cyanide Destruction





Ultrafiltration

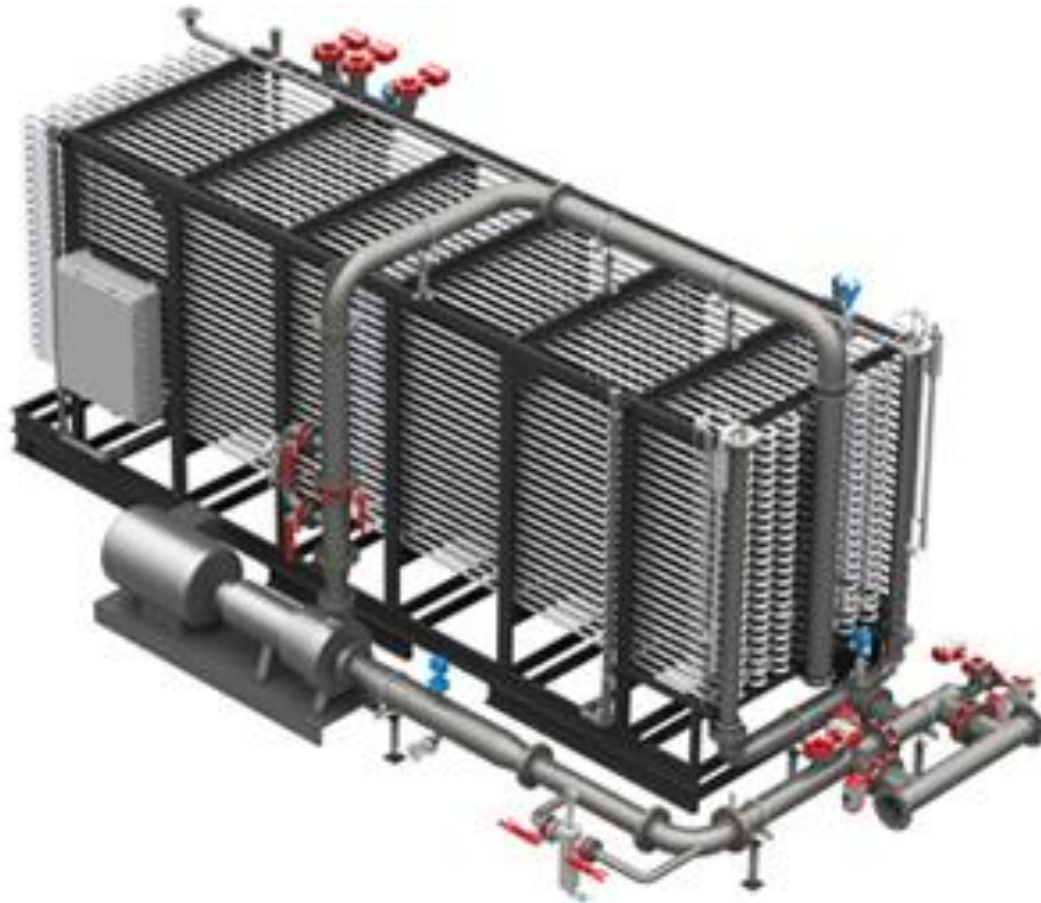

Membrane Technologies: Tight Enough to Remove Oils/Soils, but...

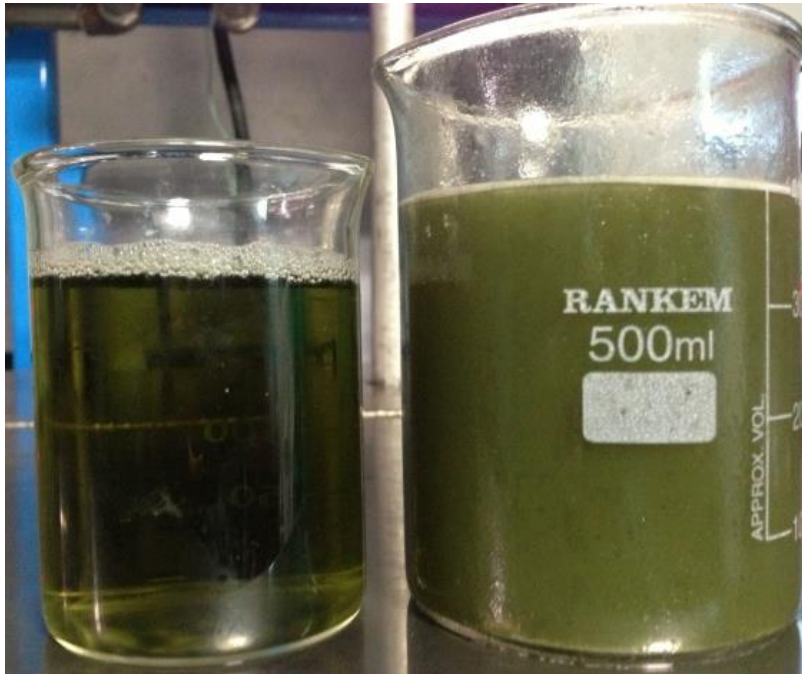

**Loose Enough
To Restore My
Cleaning Solution
(Cleaner & Water)**

How Does It Work... THE SEQUEL!

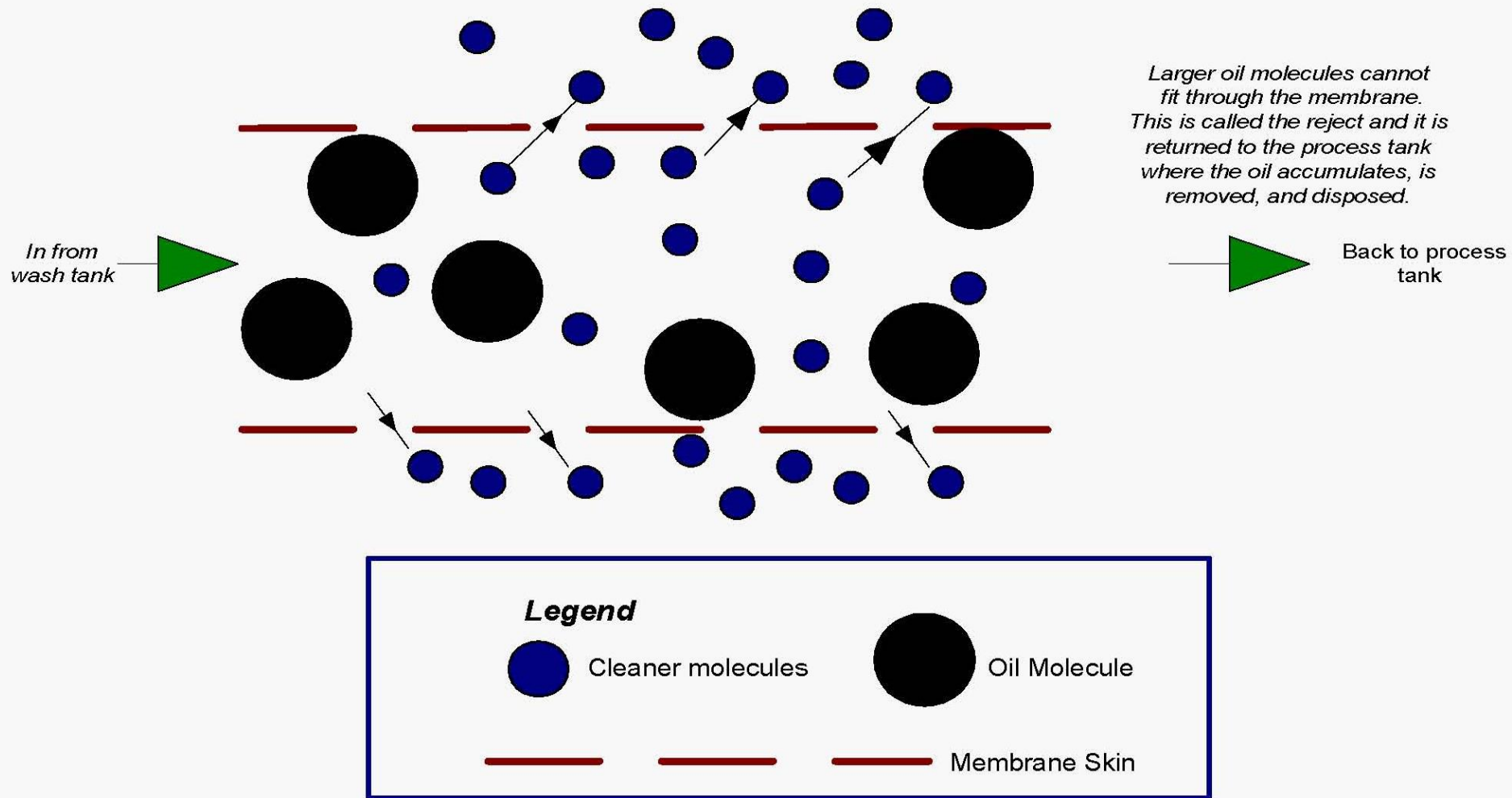

Ultrafiltration

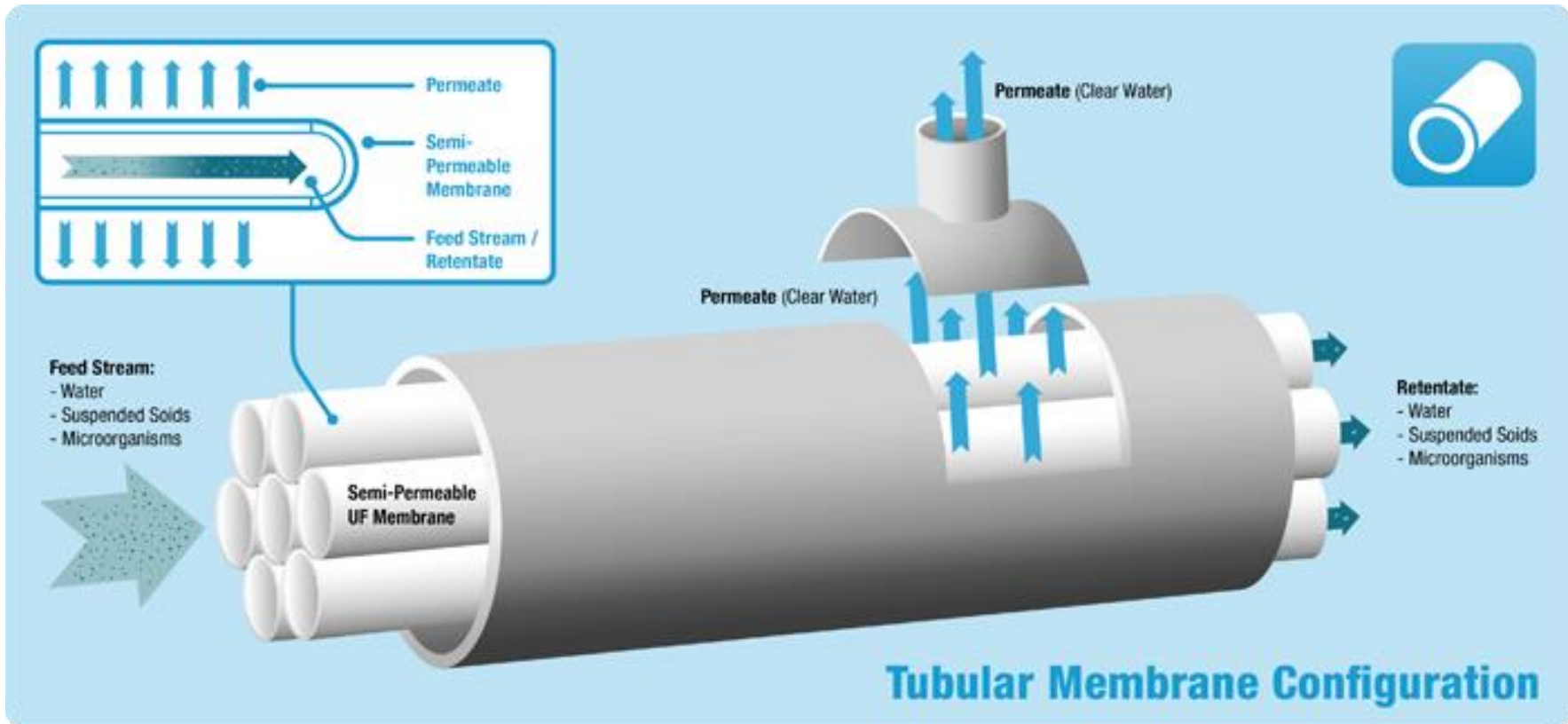

Membrane Construction



Ceramics (C)



Polymeric (P)

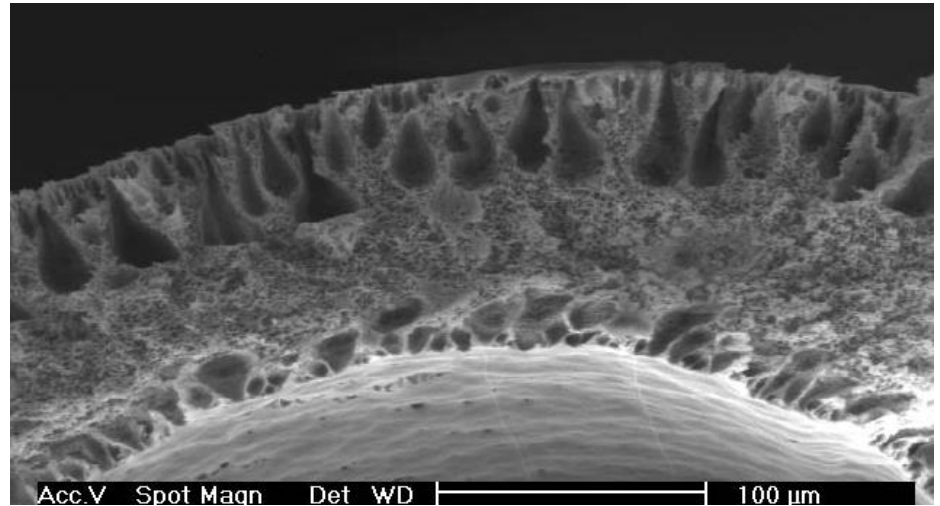
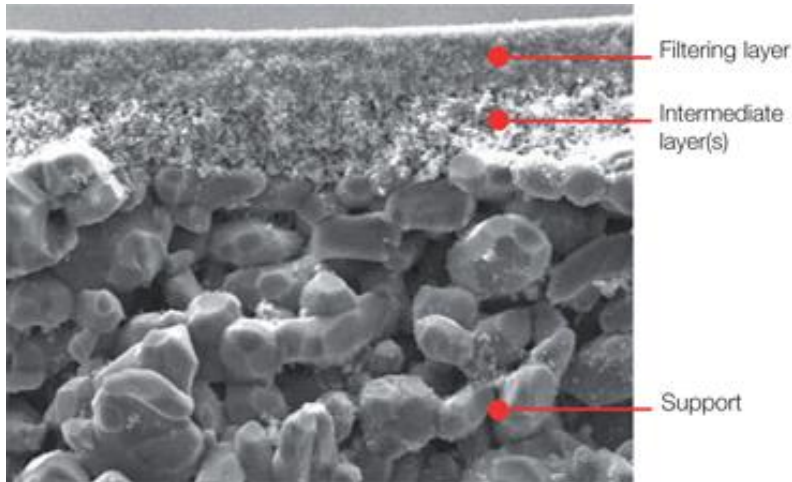

Solving Cleaning Issues

Typical Membrane System Flow Schematic

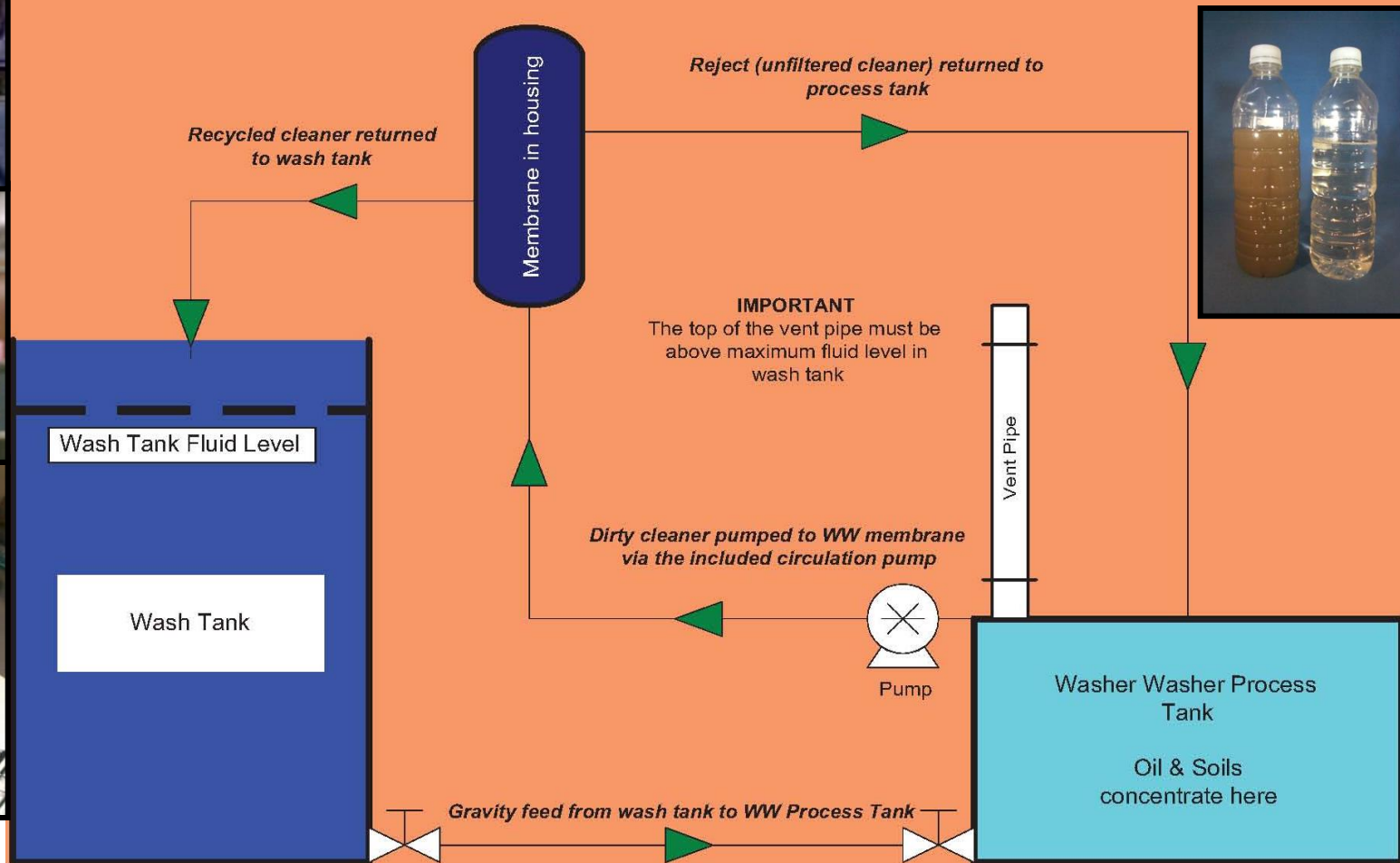



Long-Term Results

Before Project

During Piloting

After WW Purchase

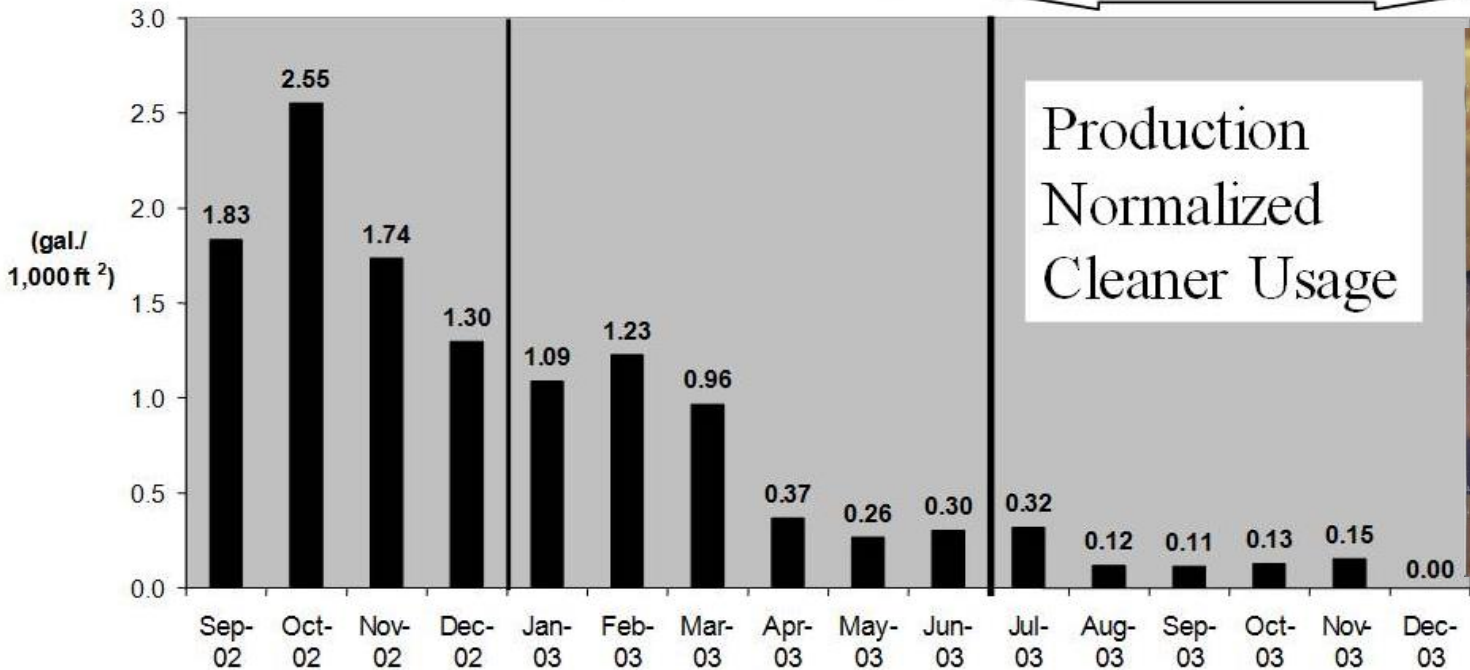

Production Normalized Cleaner Usage

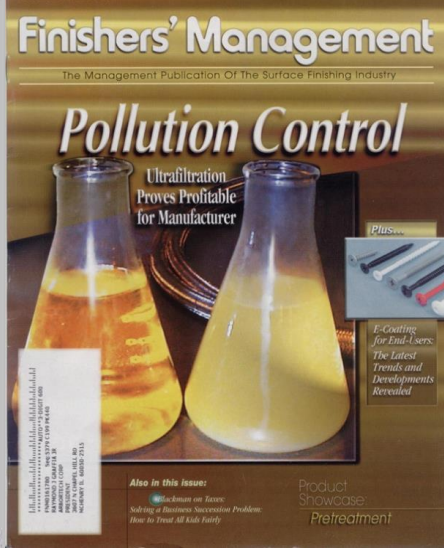

Arbortech Confidential
Proprietary

Floor Wash Solution Recycling...

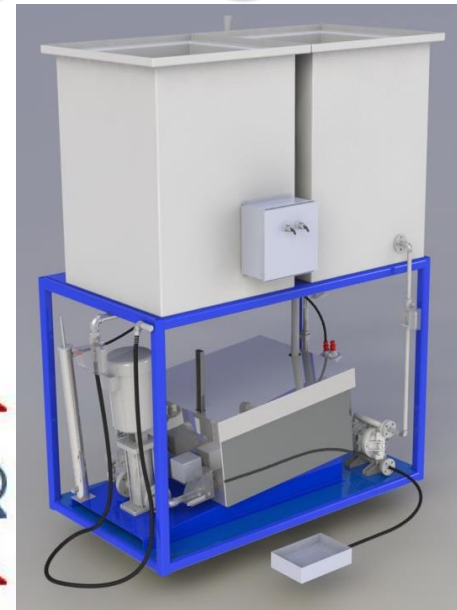
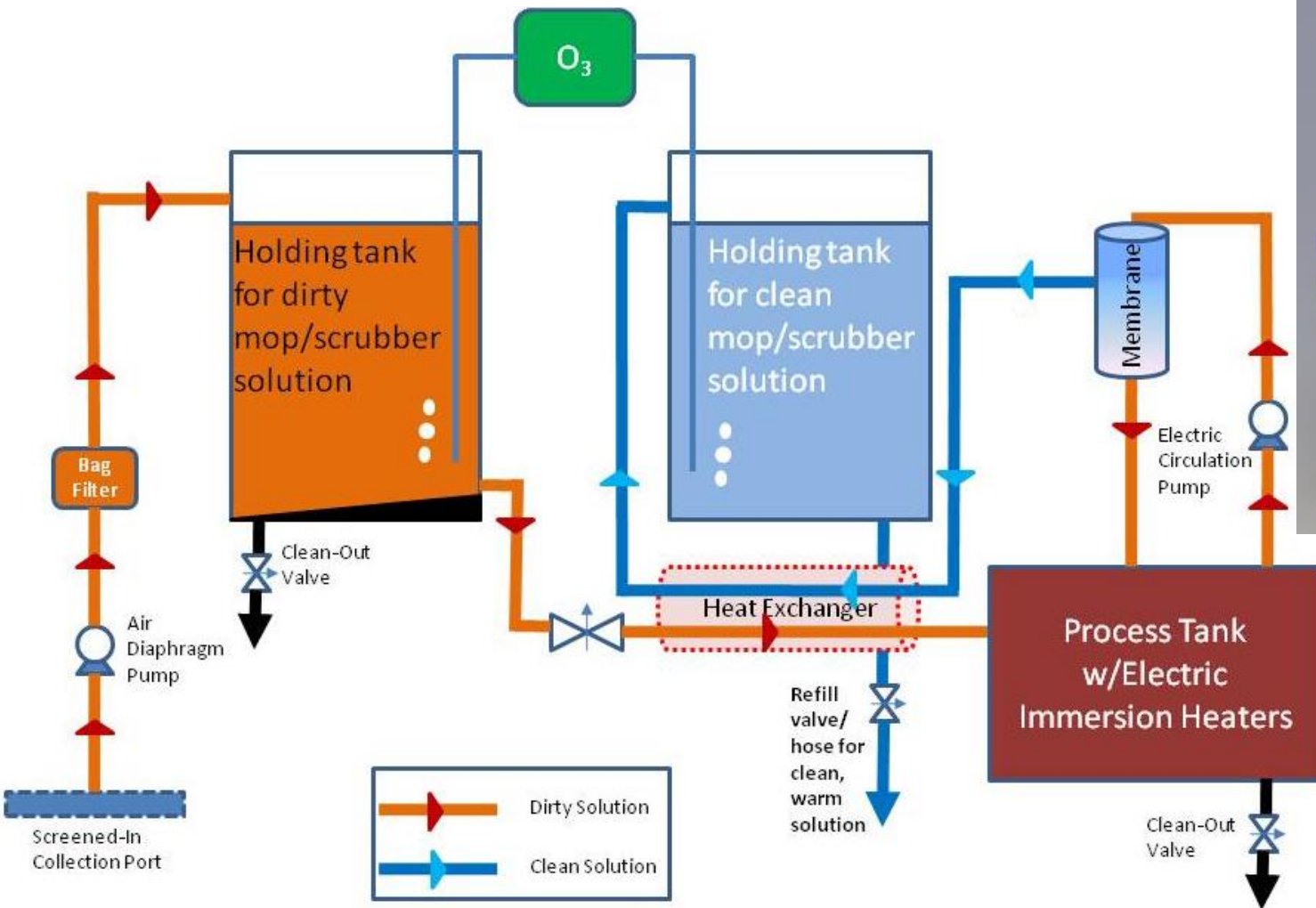

Cartridge Filter with Oil Extractor



*1 cartouche L-TECH 10"
pour filtre L*



*1 cartouche L-TECH 20"
pour filtre L*



*4 cartouches L-TECH 20"
pour filtre P*



Evaporators (Steam, Gas, or Electric)



Moving Bed Biological Reactor (MBBR)



Membrane BioReactor (MBR)

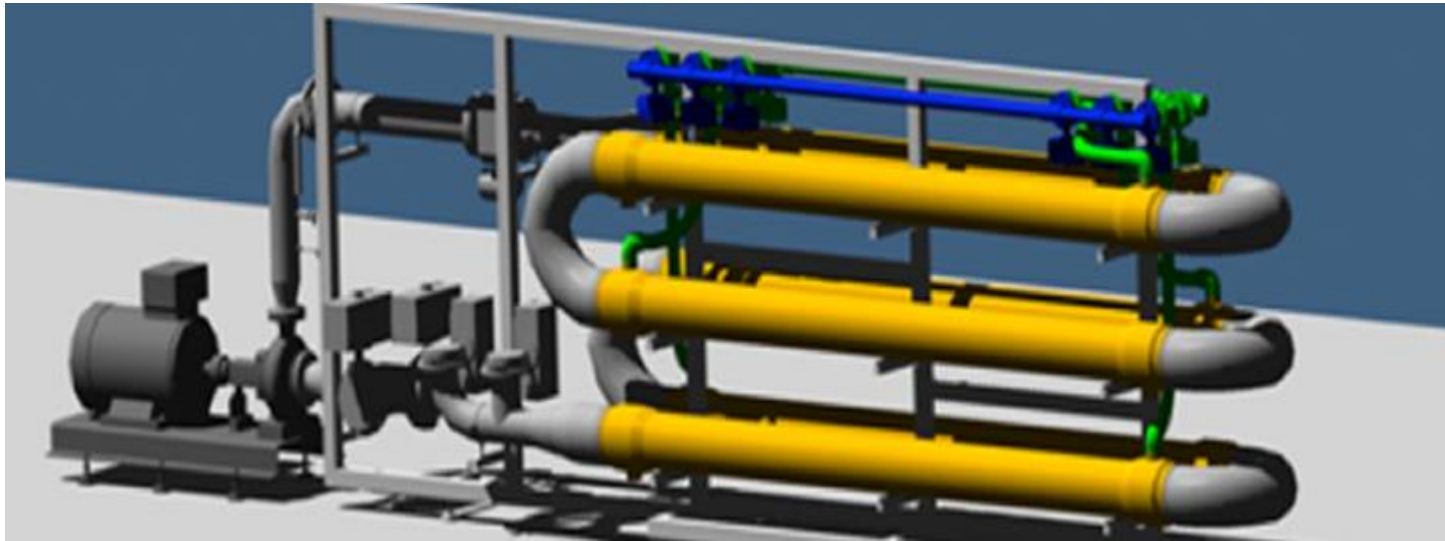

INDUSTRIES SERVED

Food & Beverage

- BREWERY
- SOFT DRINKS & JUICE
- MEAT/POULTRY/FISH/SEAFOOD
- DAIRY
- CONFECTIONARY
- POTATO & FOOD PRODUCTS
- SNACK FOODS
- PREPARED FOODS
- AND MANY MORE!



ANAEROBIC FUNDAMENTALS

WASTEWATER containing
Carbohydrates, Fat, Proteins, dissolved and undissolved

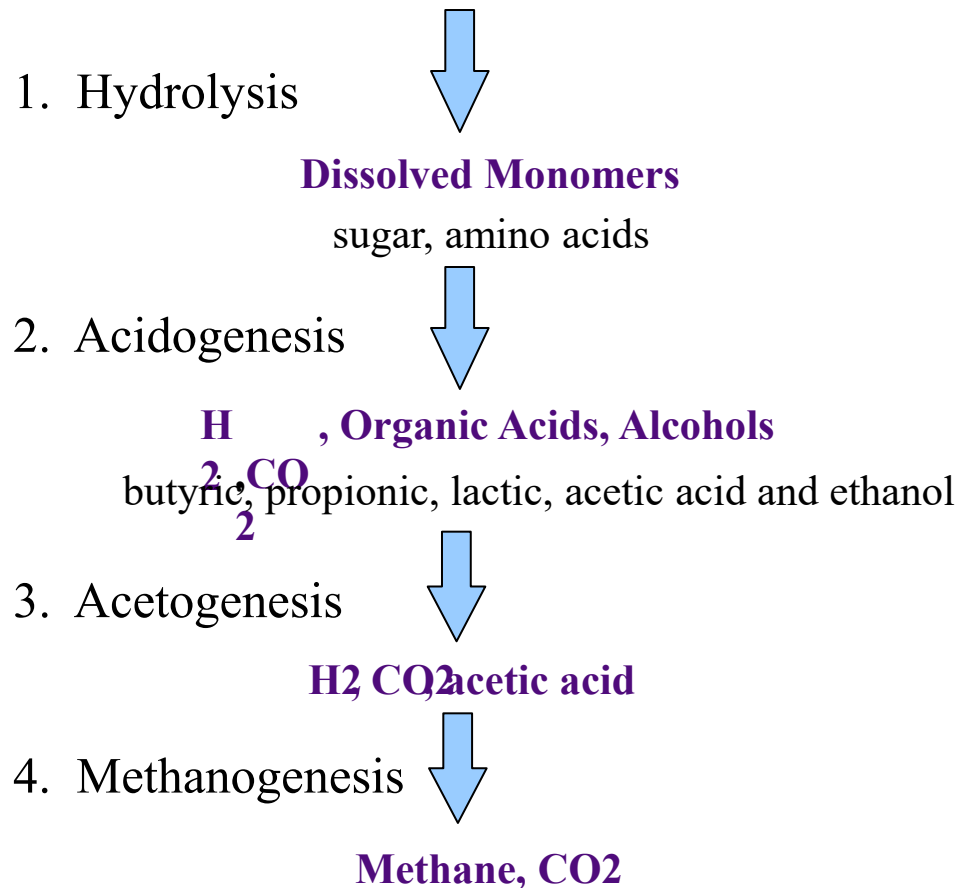

ADVANTAGES OF ANAEROBIC TREATMENT

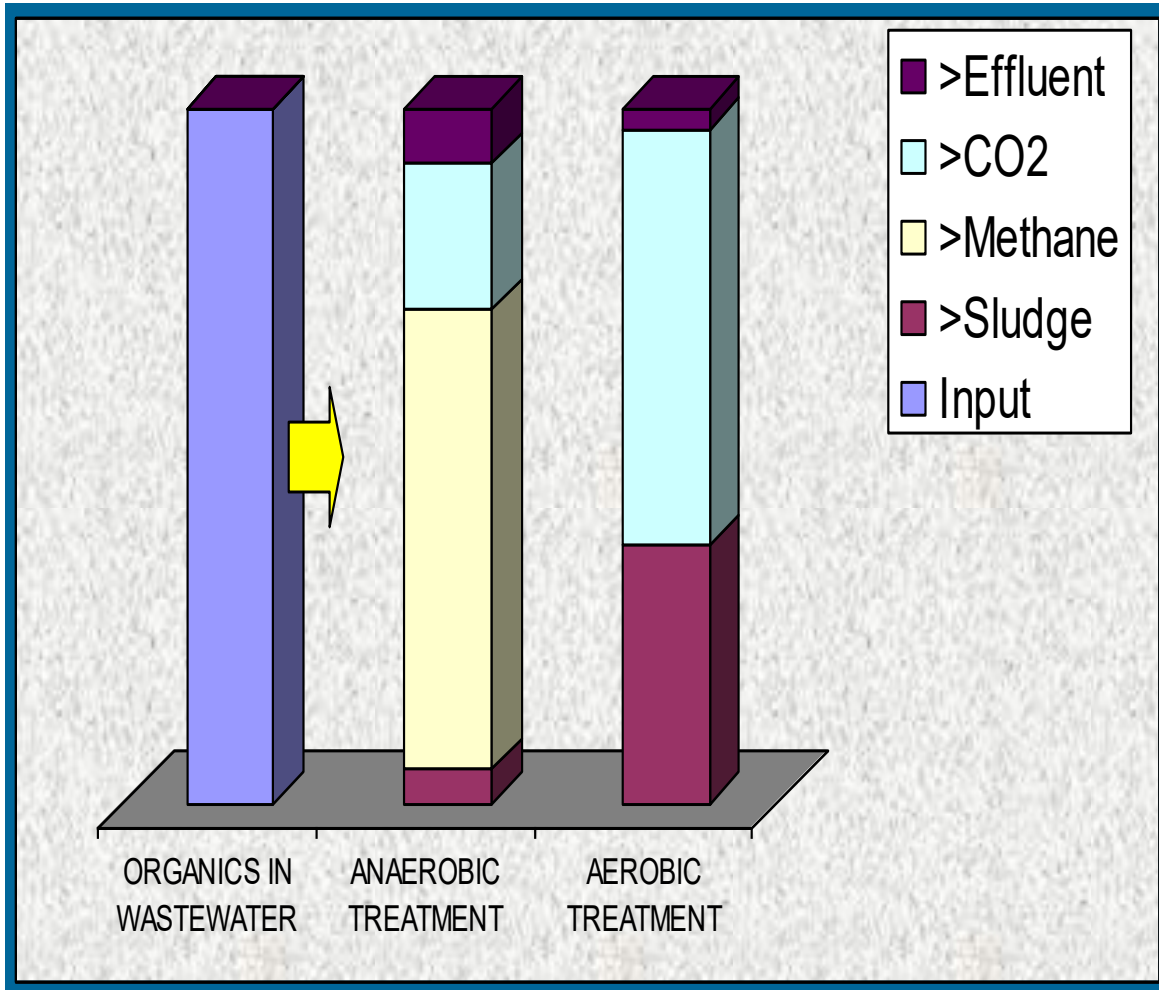

**Anaerobic
vs
Aerobic**

**MAKE
BIOGAS,
NOT
SLUDGE!**

BIO-SULFURIX™ and SULFURIX BIOGAS scrubberS

- **Biosulfurix**
 - Biological scrubber
 - CONTROLLED H_2S TO H_2SO_4/S OXIDATION
 - AIR or OXYGEN ADDITION TO BIOGAS
 - THIOBACILLUS spp. BIOMASS ON CARRIER
- **Sulfurix**
 - Wet scrubber
 - DISSOLVING H_2S IN AERATED WASTEWATER OR SLUDGE
 - OPTIONAL pH CONTROL AND OXYGEN ADDITION



BIOGAS UTILIZATION



**Steam
boilers**



**Combined heat
and power
(CHP) systems**



CHOBANI

South Edmeston, NY

- Greek yogurt production
 - Screening
 - Equalization
 - pH adjustment
 - DAF pretreatment
 - Industrial mbr
 - 2 trains of Ax/pa/membranes
 - 1.0 mgd
 - 6,000/3,000/90/15 mg/l (cod/bod/tn/tp)
 - 5/5/1/0.05 mg/l (bod/tss/ammonia/tp)
 - Fast-track project
 - Direct-discharge to sensitive river
 - Startup 2011

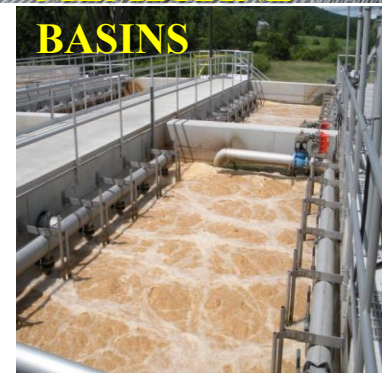
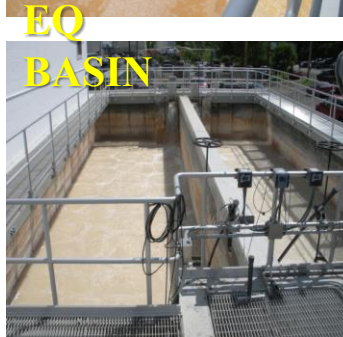
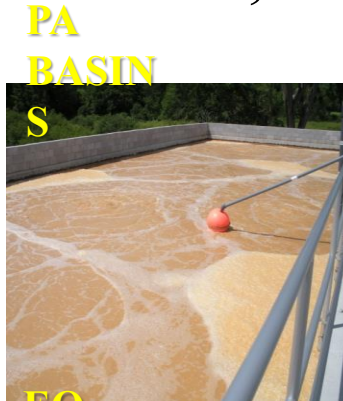

Chobani, twin falls, ID

Greek yogurt production

- Screening
- Equalization + calamity tanks
- Ph adjustment
- Daf pretreatment + float storage tank
- Influent/effluent heat recovery
- Calorix heating (biogas/ng)
- Anubix-b uasb
- Waste sludge storage
- Gwe Elevated biogas flare
- Odor control
- 1.0 mgd
- 3,000/1,830 mg/l (cod/bod)
- Pretreatment to city sewer
- Startup 2013



ODWALLA (Coca-cola NA) Dinuba, CA

- Fruit juices and beverages production

- Screen
- Equalization
- Ph adjustment
- Anubix-b uasb Anaerobic
- Sludge storage 
- Odorix
- Gwe flare

- 250,000 gpd
- 5000/3250 (cod/bod)
- Irrigation disposal
- Startup 2003



GLAXO-SMITH-KLINE (GSK)

Oak Hill, NY

- Toothpaste manufacturing wastewater
- Industrial MBR
- Influent Characteristics:
 - Flow = 42,000 GPD
 - COD = 1045 mg/L
 - TSS = 77 mg/L
 - NH₃-N = 11.5 mg/L
- Effluent Requirement:
 - COD ≤ 86 mg/L
 - TSS < 10 mg/L
 - NH₃-N < 1.7 mg/L
- Phys/chem pretreatment system for zinc/silic
- Startup 2012



Brewery OMMEGANG

Cooperstown, NY

- CRAFT BREWERY
 - Screening
 - Equalization
 - Nutrient addition
 - Industrial mbr
 - 40,000 gpd
 - Rww
 - 15,000/8,000/2,000 mg/l (cod/bod/tss)
 - Effluent
 - nd/nd/<1/<1, mg/l (bod/tss/tn/tp)
 - Discharge to Susquehanna river
 - Startup 2013



BREWERY
OMMEGANG
BELGIAN STYLE ALES • COOPERSTOWN, NY

Anno 1871

Duvel



Brewery OMMEGANG Cooperstown, NY



E&J GALLO WINERY LIVINGSTON, CA

World's largest single location winery

- High-strength winery and distillery wwt
 - Screening
 - Equalization
 - Ph adjustment
 - Anubix-t egbs anaerobic
 - Influent/effluent heat recovery
 - Hot water + hx heating (residual chp heat)
 - Waste sludge storage
 - Gwe temperature-controlled biogas ground flare
 - biosulfurix biogas scrubber
 - Gasodrix biogas dryer
 - Odor control
 - Industrial mbr polishing of anaerobic effluent
 - 0.47 mgd; 12,000 mg/l cod (anaerobic)
 - 0.535 MGD; 2,100 mg/l COD (aerobic)
 - effluent to irrigation; 50/50/50 (bod/tss/tn)
 - Startup 2014



50% HCL with/without PRO-pHx

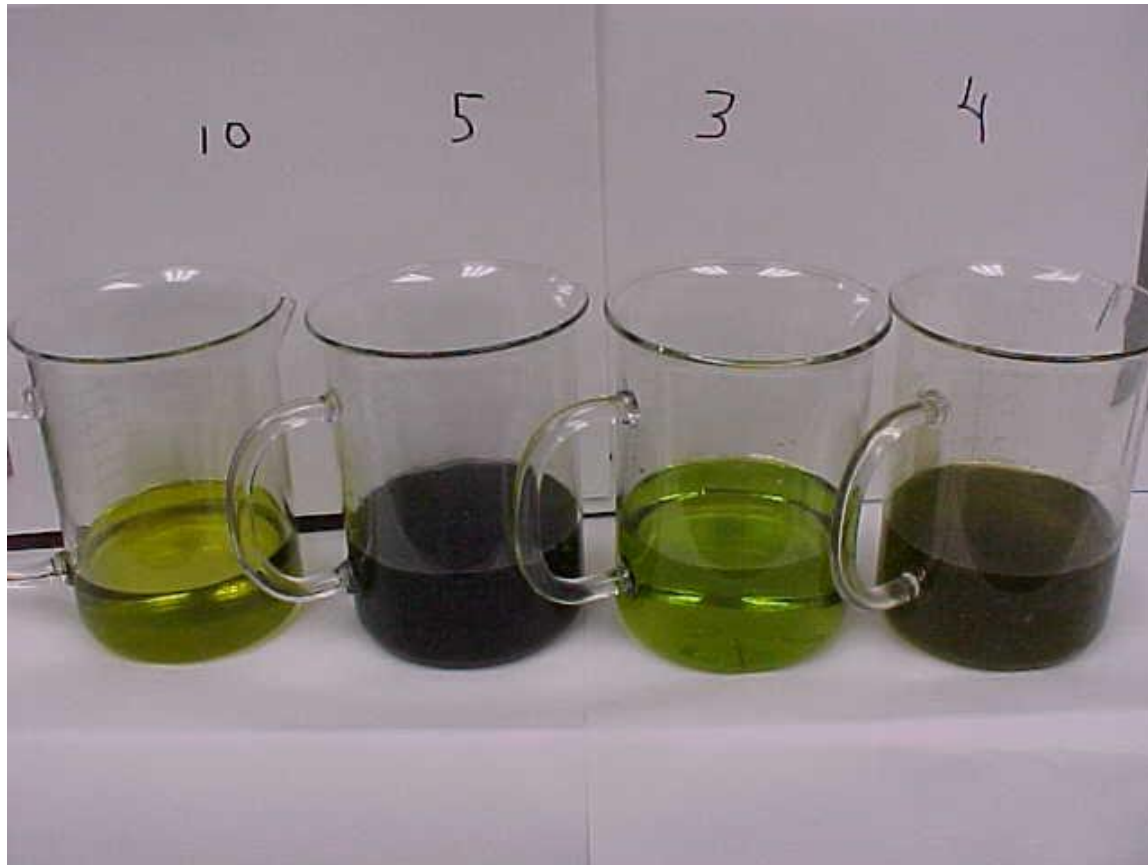

BEFORE PRO-pHx

Results reference

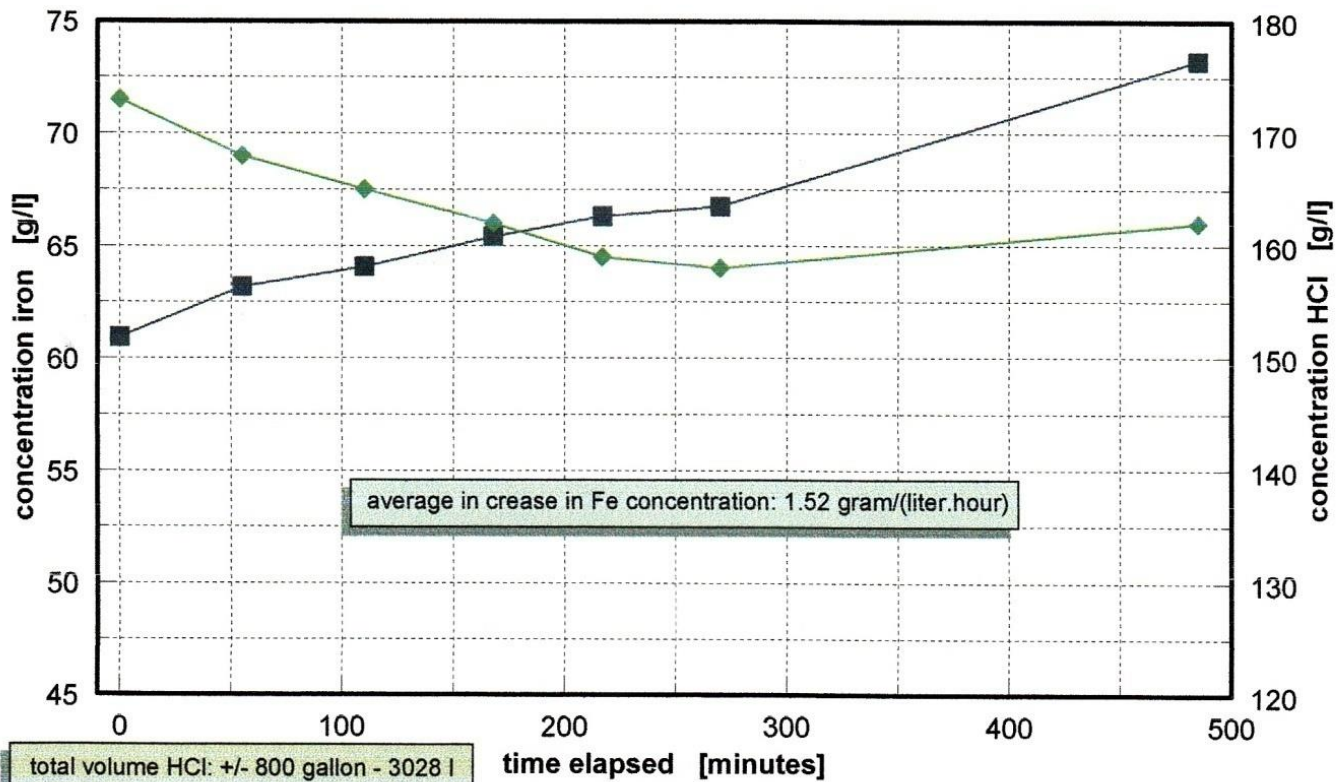

AFTER PRO-pHx

Results trial #02

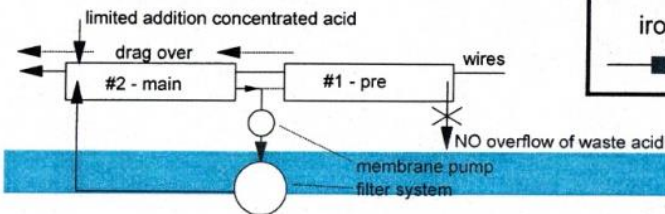
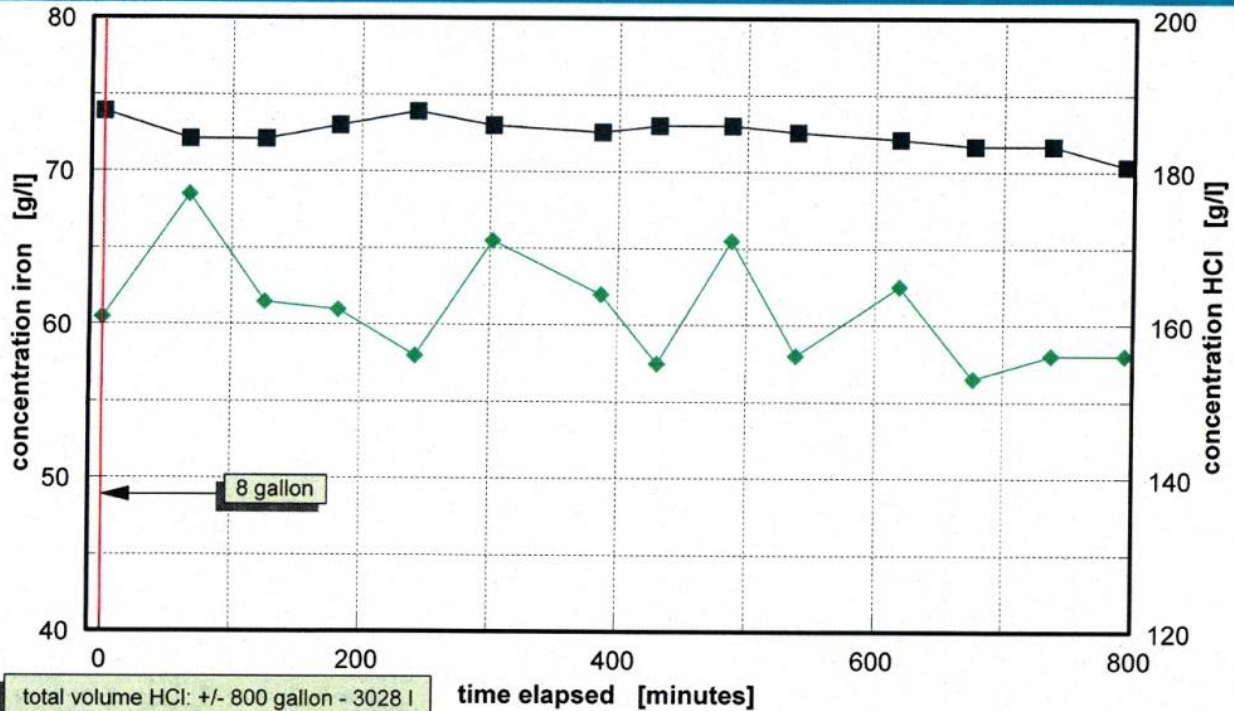

FloKing Cartridge Filter

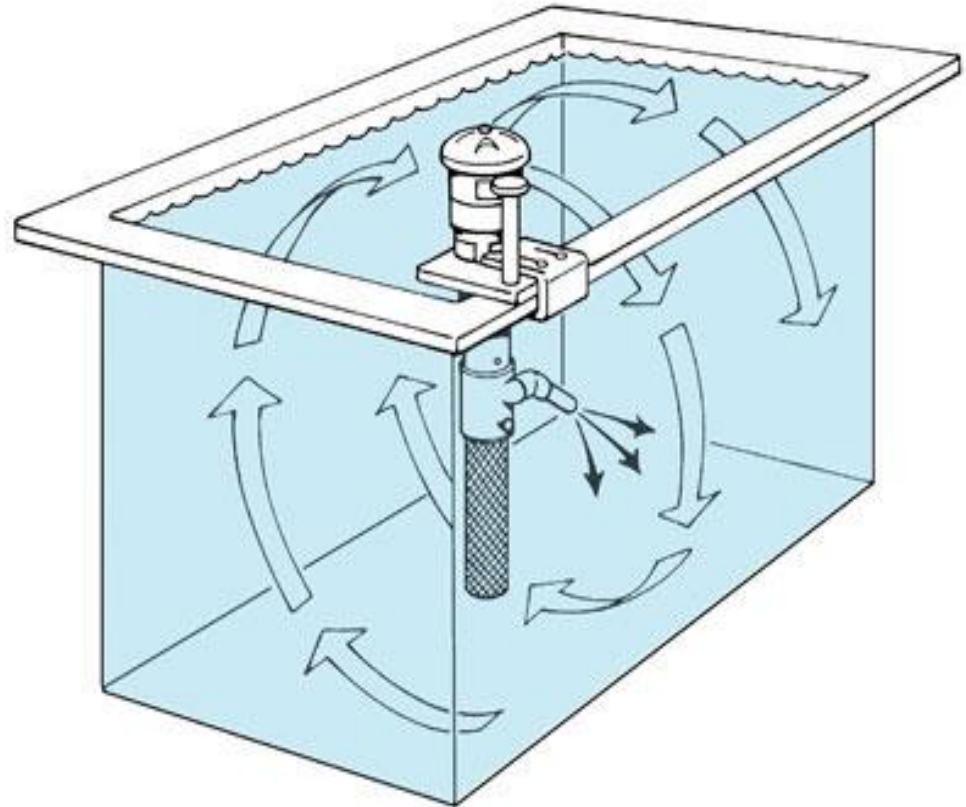

Global Filter – Automatic Backwash



Questions



Thank You