



ADVANCED PIPE CLEANING

Certified Trainer: Ed Fitzgerald

Jack Doheny Companies

Who Are We?

Jack Doheny Companies is the world's largest distributor of sewer cleaning and industrial air handling equipment.

We specialize in:

- Nations Largest Rental Fleet
- Flexible Rental Options
- Remanufactured Equipment
- "We Service What We Sell"



Locations

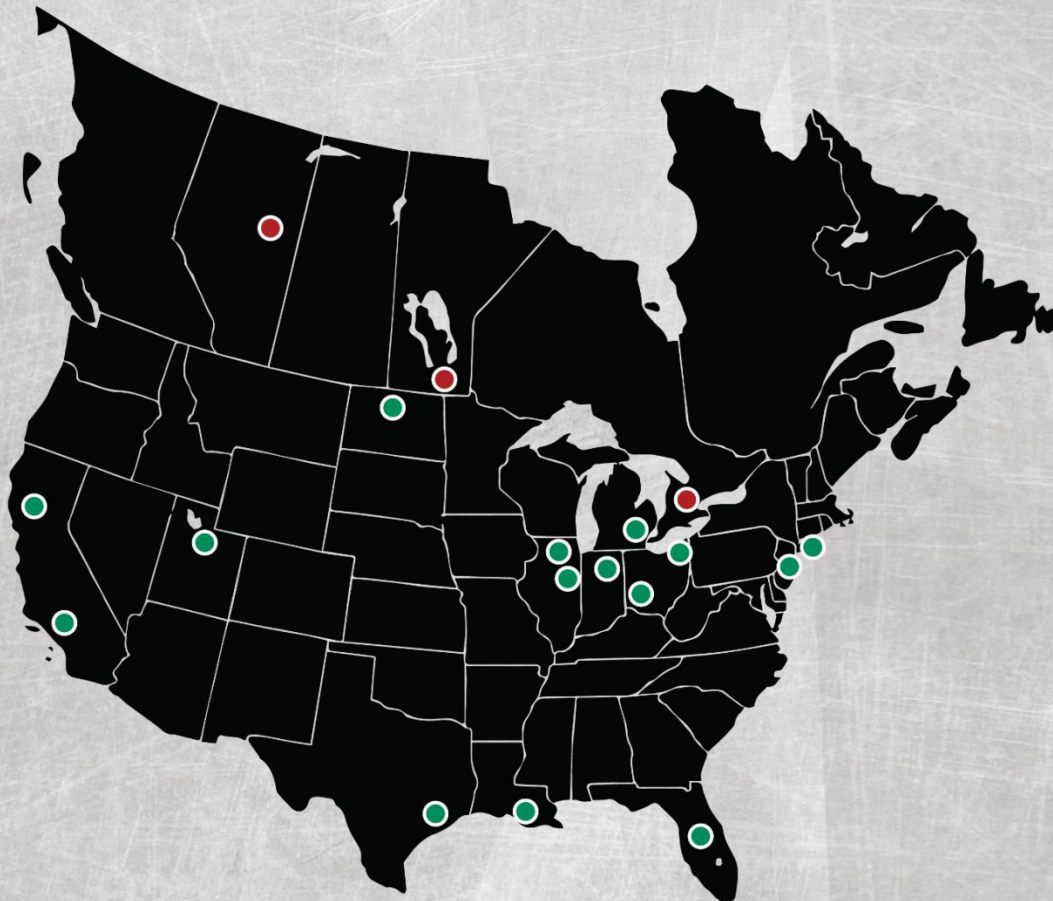

Antioch, California

Bay Shore, New York,

Cincinnati, Ohio

Gonzales, Louisiana

Island Lake, Illinois

Joliet, Illinois

La Porte, Texas

Long Beach,
California

Minot, North Dakota

Northville, Michigan

Orlando, Florida

Salt Lake, Utah

Twinsburg, Ohio

Wharton, New Jersey

Whitestown, Indiana

Alberta, Canada

Manitoba, Canada

Ontario, Canada

Parts & Service



DOHENY TECHNICAL INSTITUTE





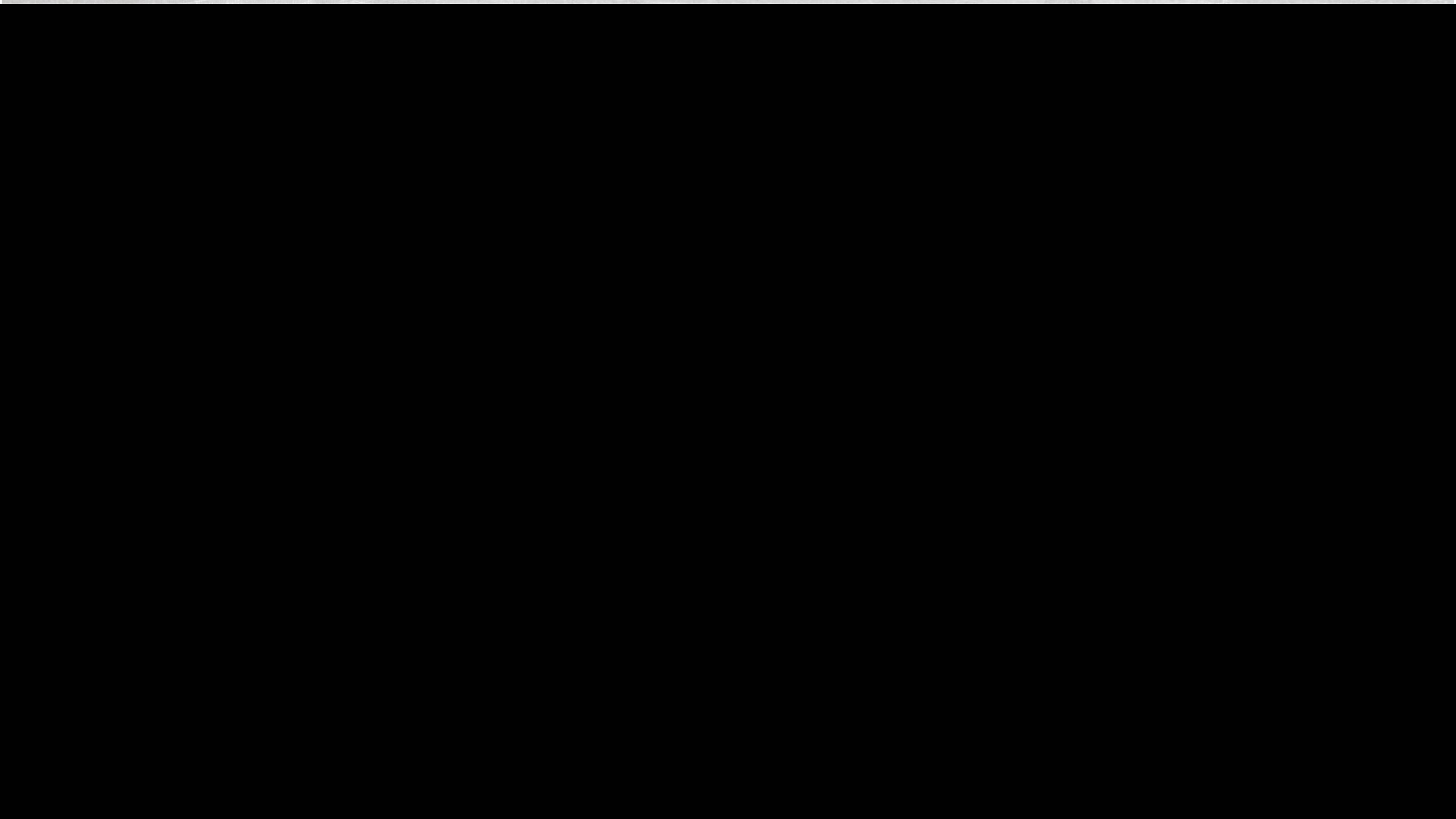

VACTOR[®]

Subsidiary of Federal Signal Corporation



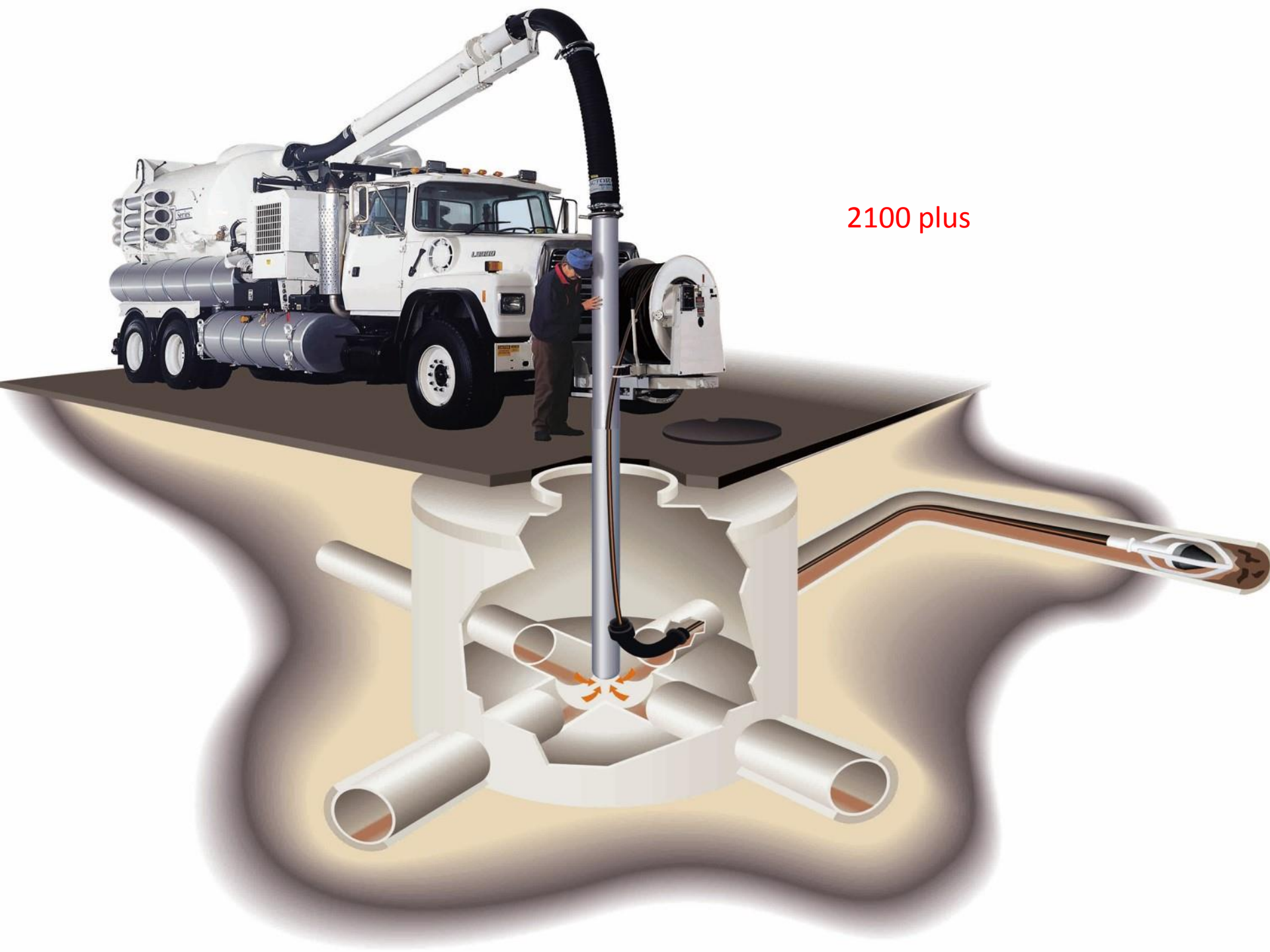

2100 plus

What is the Purpose of a Combination Machine?

- Contains & Transports
- Suction
- Water Jet

Nozzles

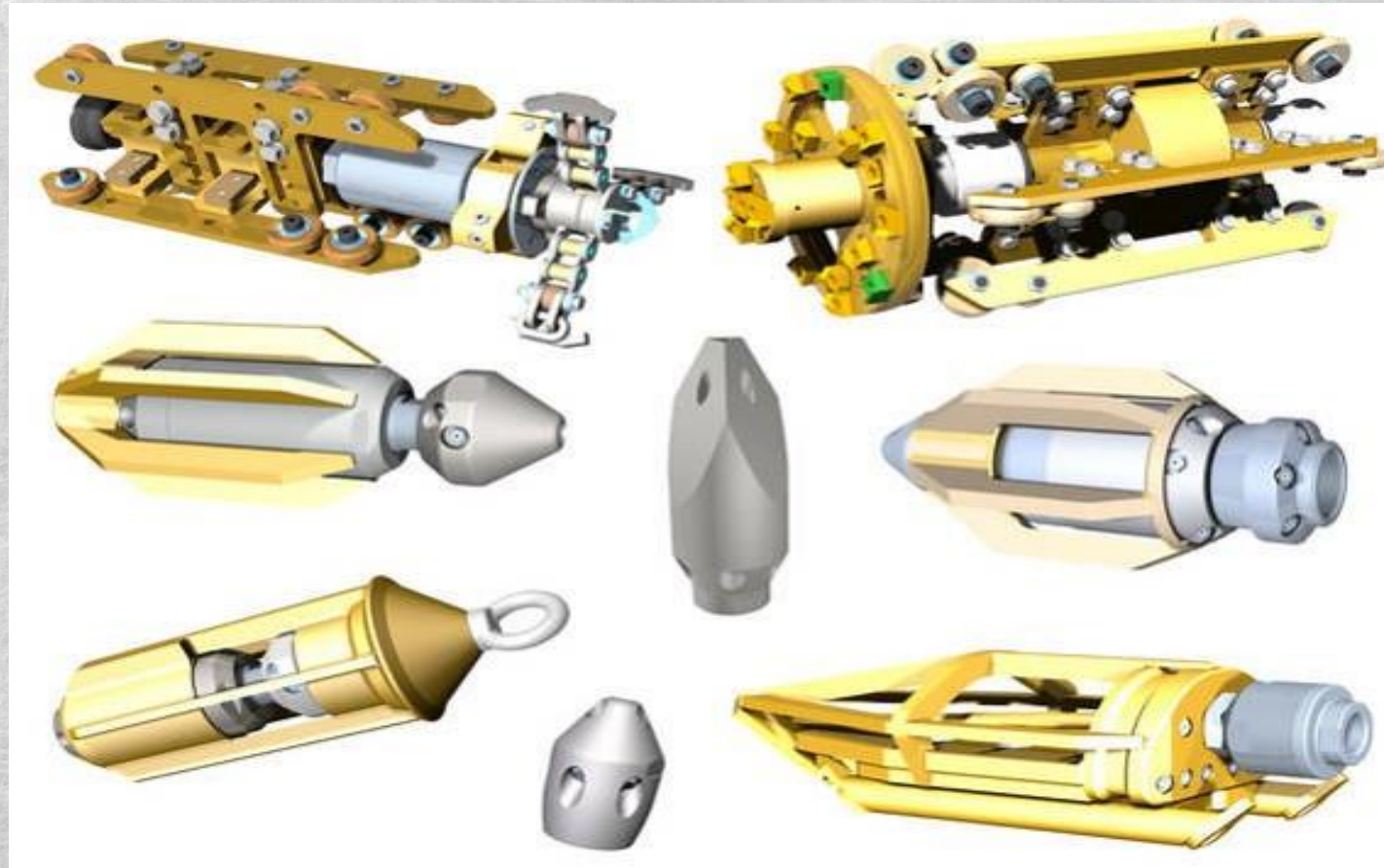

5 GPM TO 200 GPM

1200 PSI TO 4000 PSI

SMALL PIPE SIZE 3" TO 6" USE A LOWER GPM WITH
HIGHER PSI

12 TO 18 GPM AT 3000 TO 4000 PSI

MED RANGE 8" TO 15" PIPE SIZE USE A HIGHER GPM WITH LOWER
PSI

40 TO 60 GPM AT 1800 PSI TO 2500 PSI

LARGE PIPE SIZE 18" TO 60"

80 GPM TO 100 GPM AT 2000 PSI TO 2500 PSI

10 DEGREE =

- BETTER FORWARD THRUST
- LESS CLEANING ABILITY

45 DEGREE =

- BETTER CLEANING ABILITY
- LESS FORWARD THRUST

90 DEGREE=

- BEST CLEANING
- NO THRUST

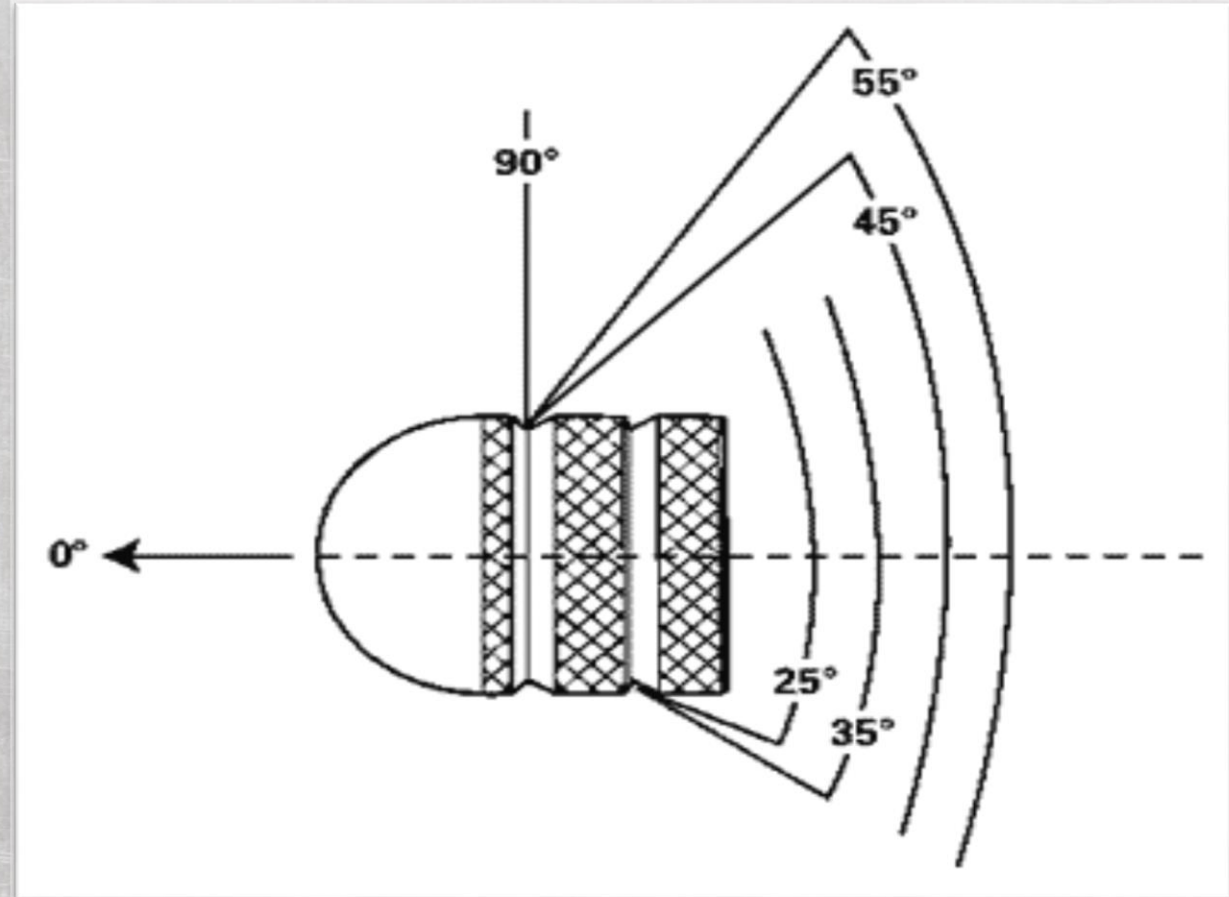

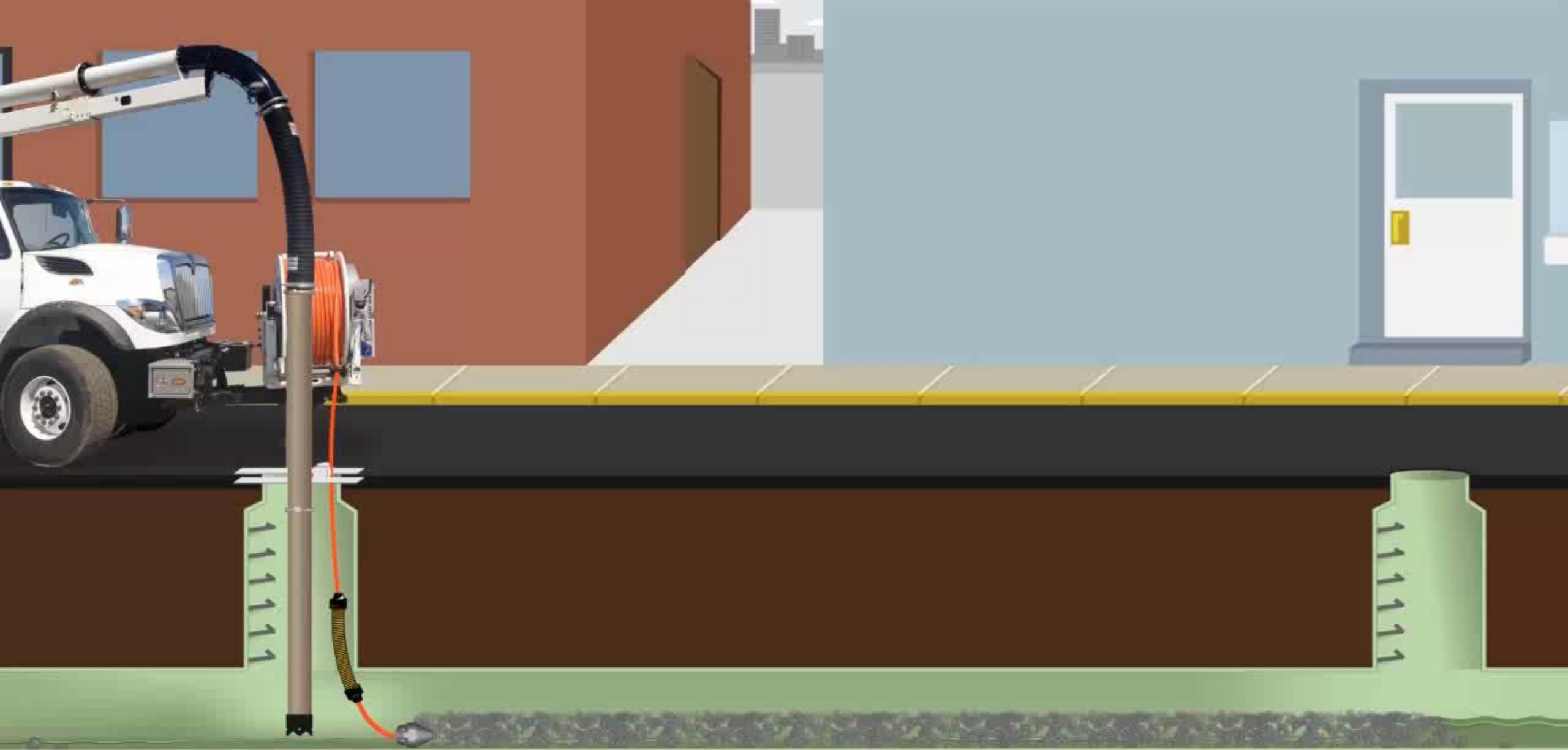

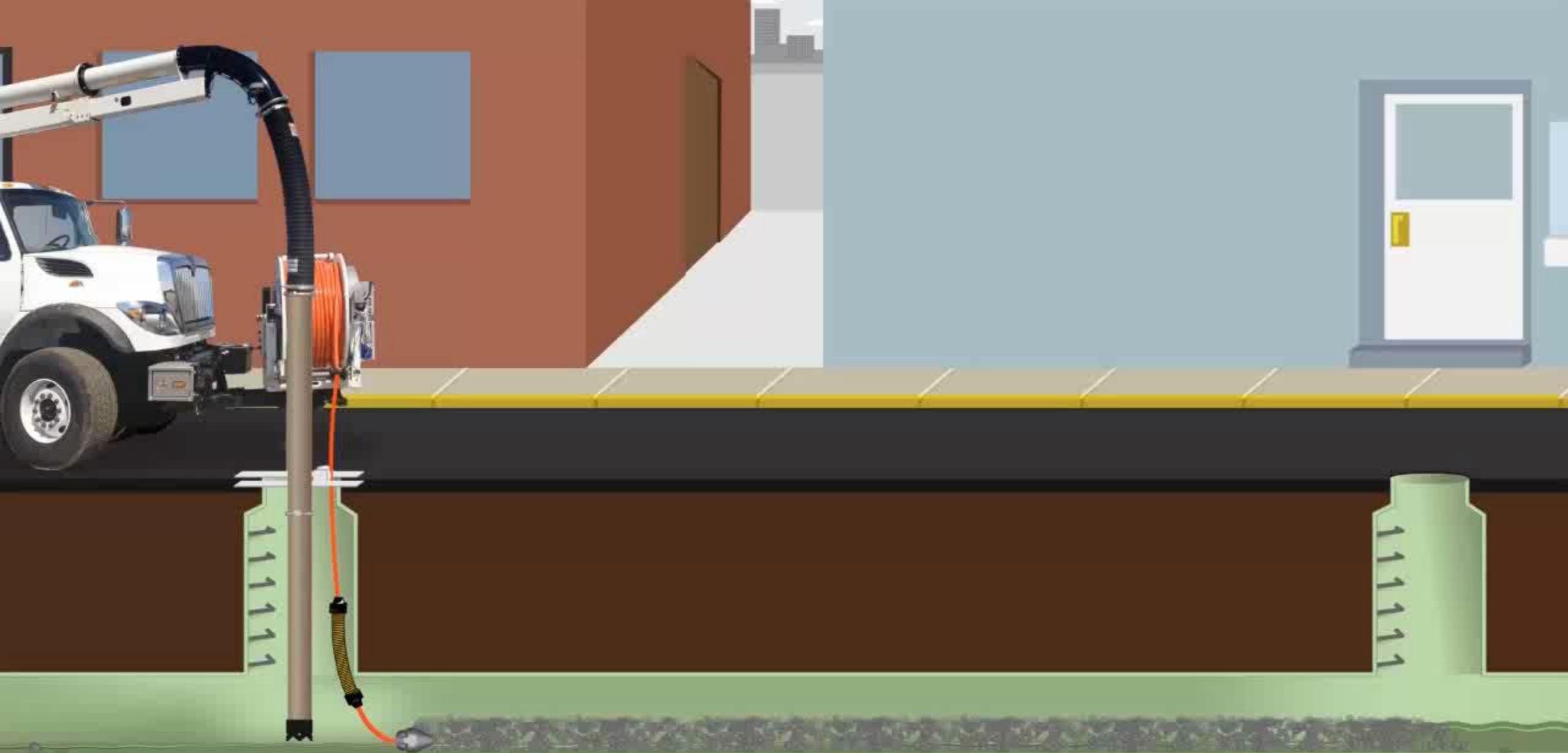

No Vacuum, No Debris Removal

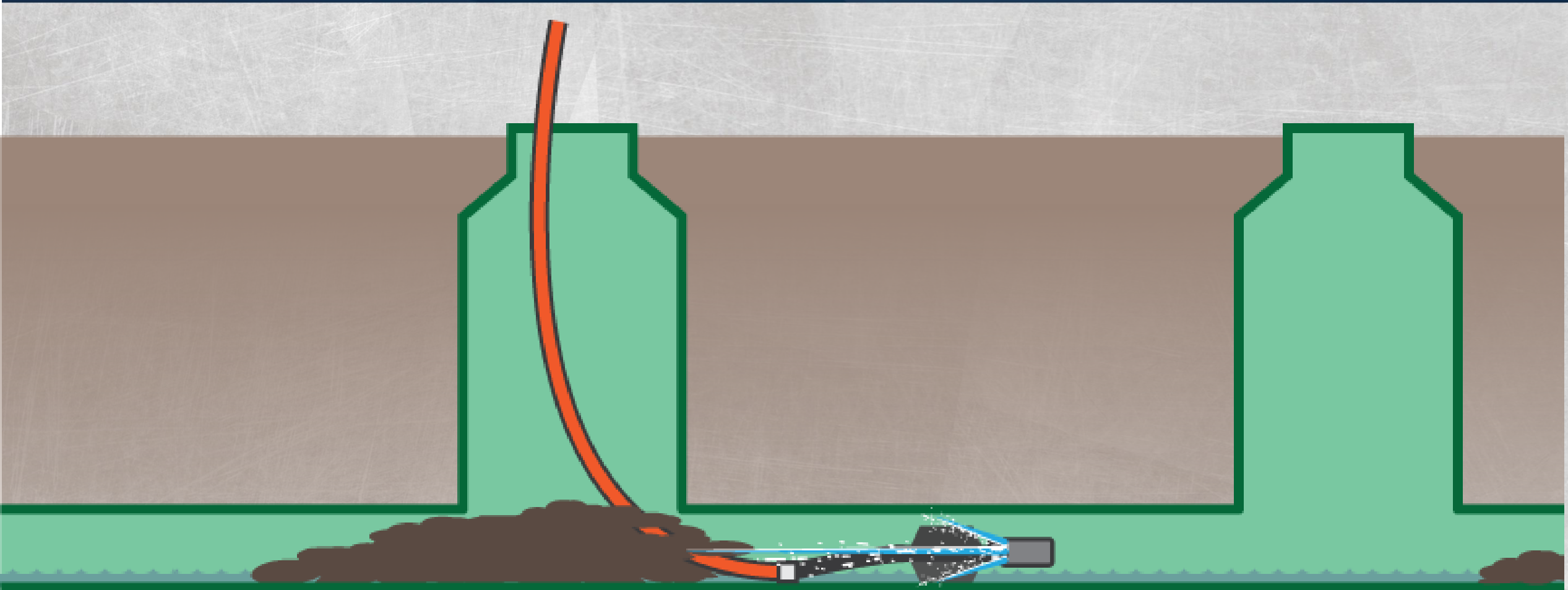

Vacuuming and Eliminating the Debris

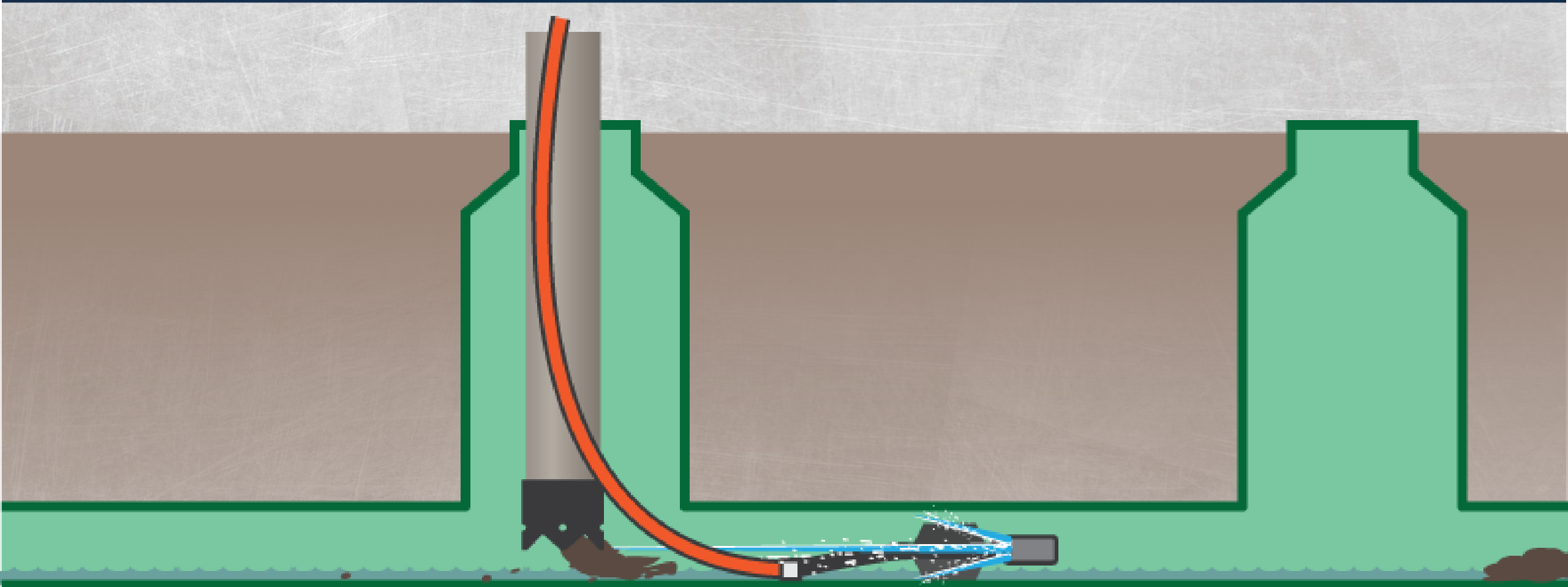

General Cleaning



- THE BEST SELECTION FOR GENERAL CLEANING IS A NOZZLE THAT USES A MULTIPLE COMBINATION OF JETS
- MOST POPULAR GENERAL CLEANING NOZZLES USE A COMBINATION OF 10 AND 30 DEGREE



PROHIBITED FROM
RE-ENTRY TO
WORK AREA

Handing system designed
and installed by a
Licensed Plumbing
Industry Contractor
Crawford Mechanical

ELGIN

SEWER LATERAL

TO 4' AT HOME

3" VENT STACK

ADMI VALVE
ATTACH
AIR

15" VENT STACK





ADVANCED PIPE CLEANING

TOILET BLOW-UPS

Penetrating Nozzles



- USED FOR OPENING BLOCKAGES
- POINTED OR CHISEL SHAPED
- FORWARD JETS FOR PIERCING BLOCKAGES
- HEAVY IN WEIGHT FOR IMPACT

Rotators or Spinners



- USED FOR GREASE AND ROOT REMOVAL
- ROTATING NOZZLE JETS ARE AT 90 DEGREES
- FOR BEST RESULT USE A CONTROLLED OR SLOW ROTATION SPEED NOZZLE

Bottom Only Cleaners



- USED MAINLY IN STORM AND LARGE SEWER LINES WHERE THE MATERIAL IS ONLY ON THE BOTTOM
- ALL JETS ARE FACING DOWNWARD SO THE WATER SPRAY IS CONCENTRATED ON THE HEAVIER MATERIAL



DOHENY TECHNICAL INSTITUTE



DOHENY TECHNICAL INSTITUTE

Saw Type Root Cutters

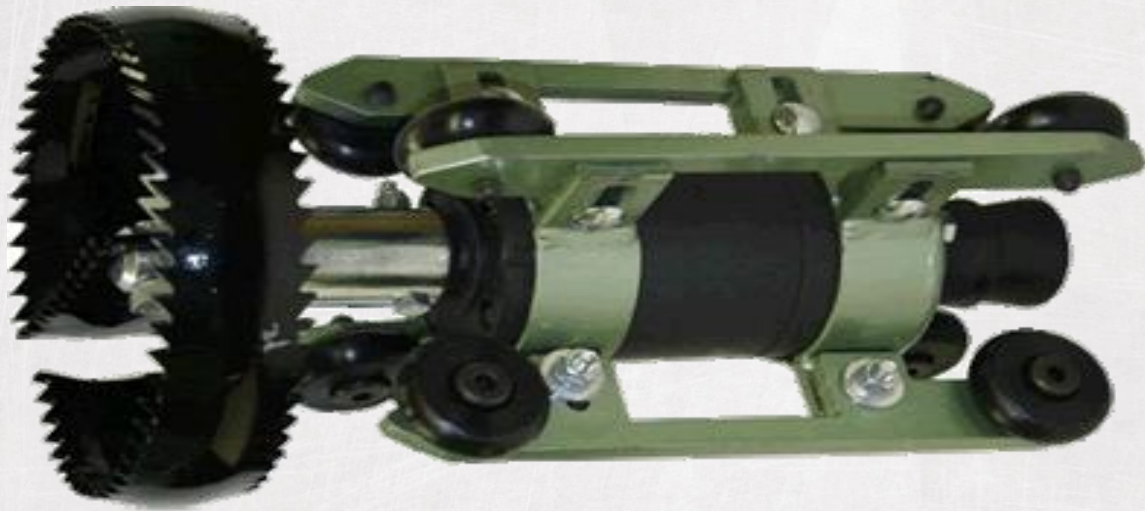

- HYDRAULIC MOTOR DRIVEN CUTTERS
- VERY EFFECTIVE ON ROOTS IN PIPE SIZES FROM 6" TO 12"
- HIGH TORQUE FOR EFFECTIVE CUTTING

NO LEADER HOSE







Chain Flail Type Cutters



- WATER DRIVEN CUTTERS
- USED FOR ROOTS AND MINERAL DEPOSITS
- 3" TO 36" PIPE SIZE
- GOOD SELECTION FOR MINERAL AND OTHER HARD DEPOSITS
- MUST BE SIZED PROPERLY FOR PIPE



8779 Royalhaven to

8743 Royalhaven

0120 .5F 06JAN05

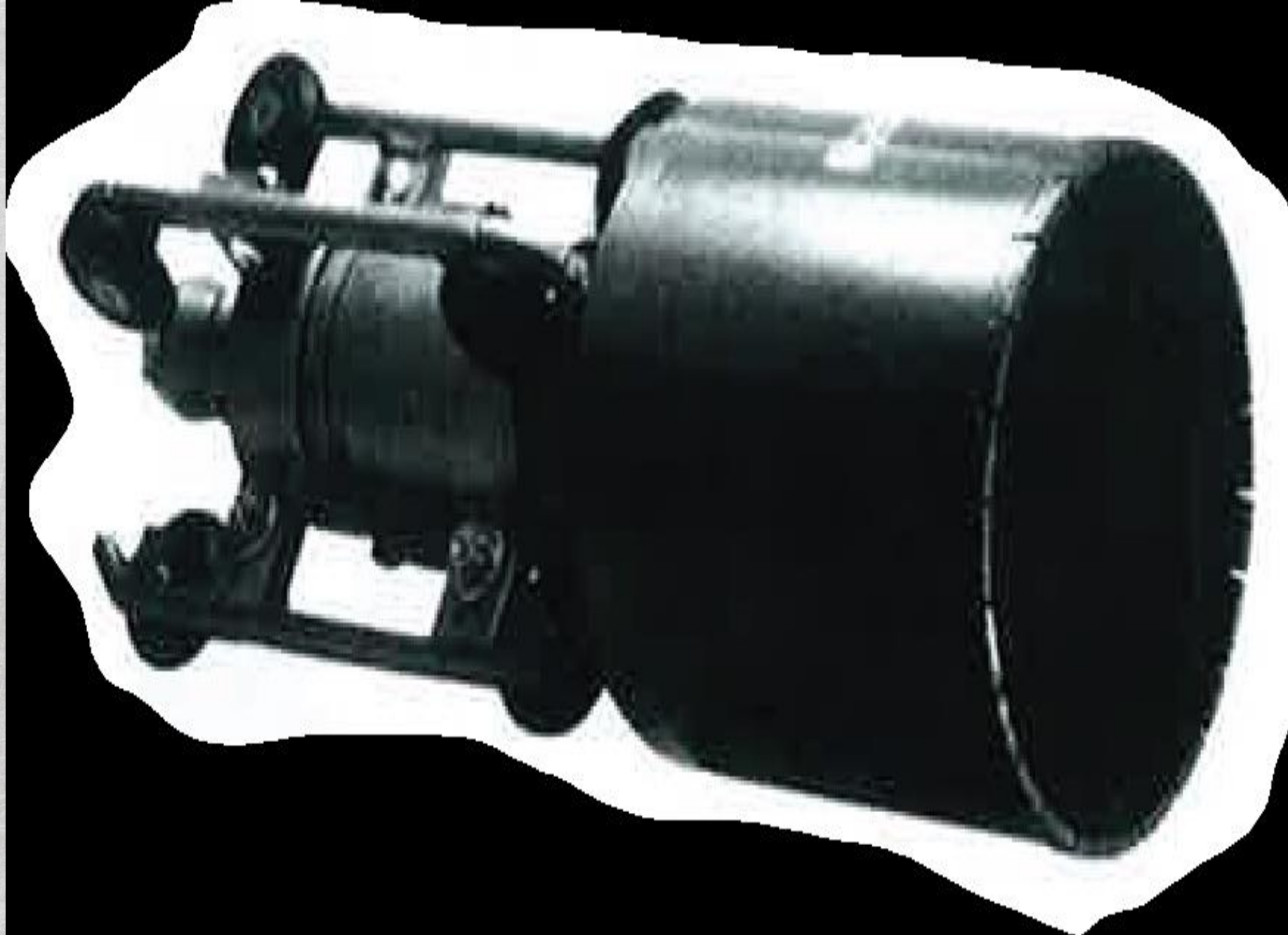

DOHENY TECHNICAL INSTITUTE



+0044. 4f
+0013. 5m

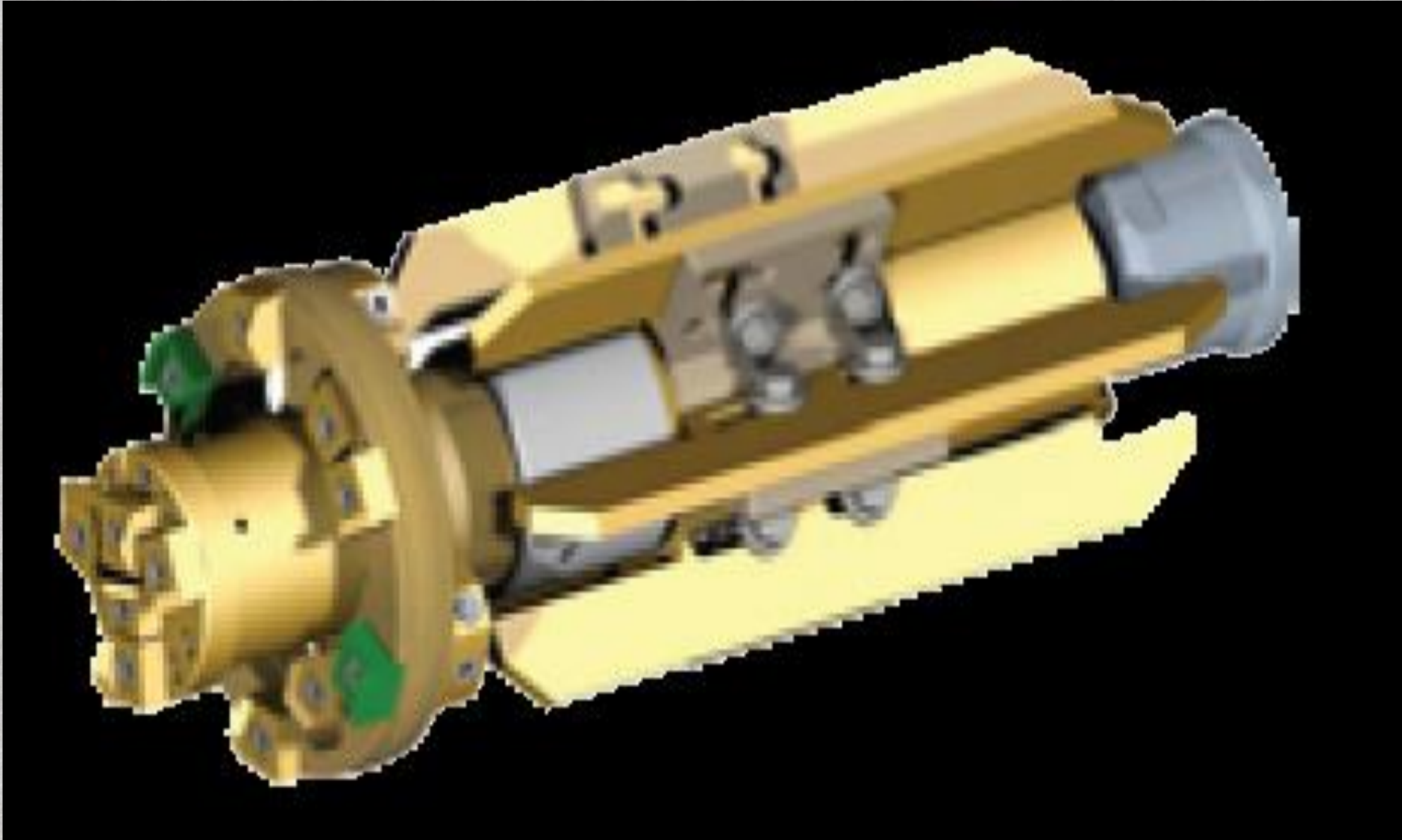

DOHENY TECHNICAL INSTITUTE

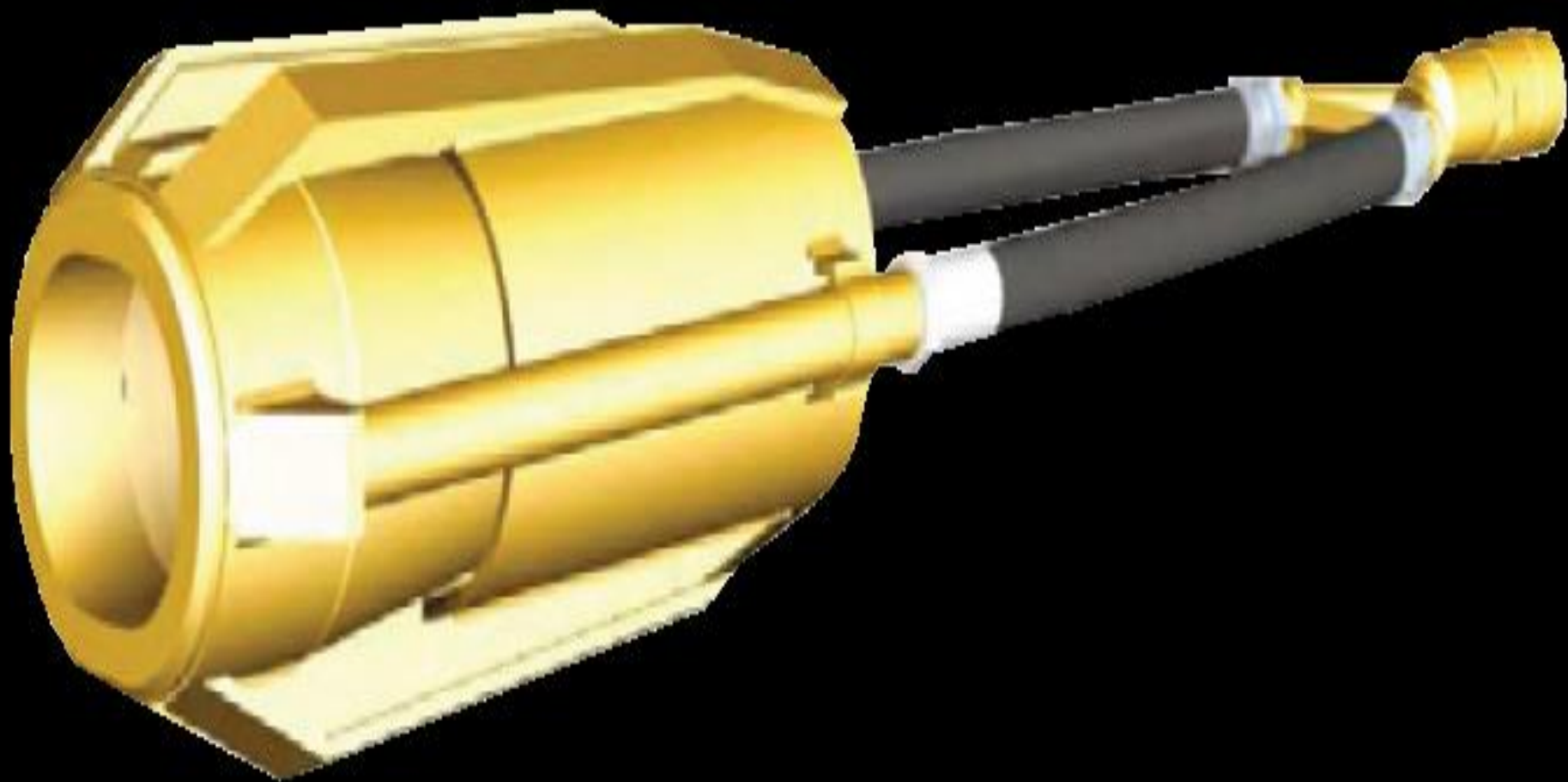

DOHENY TECHNICAL INSTITUTE

