



Wastewater Pumping System with Breakthrough Integrated Intelligence

Kristel Zaman

Flygt Product Marketing Manager

Xylem North America

Kristel.zaman@xyleminc.com



Global water trends

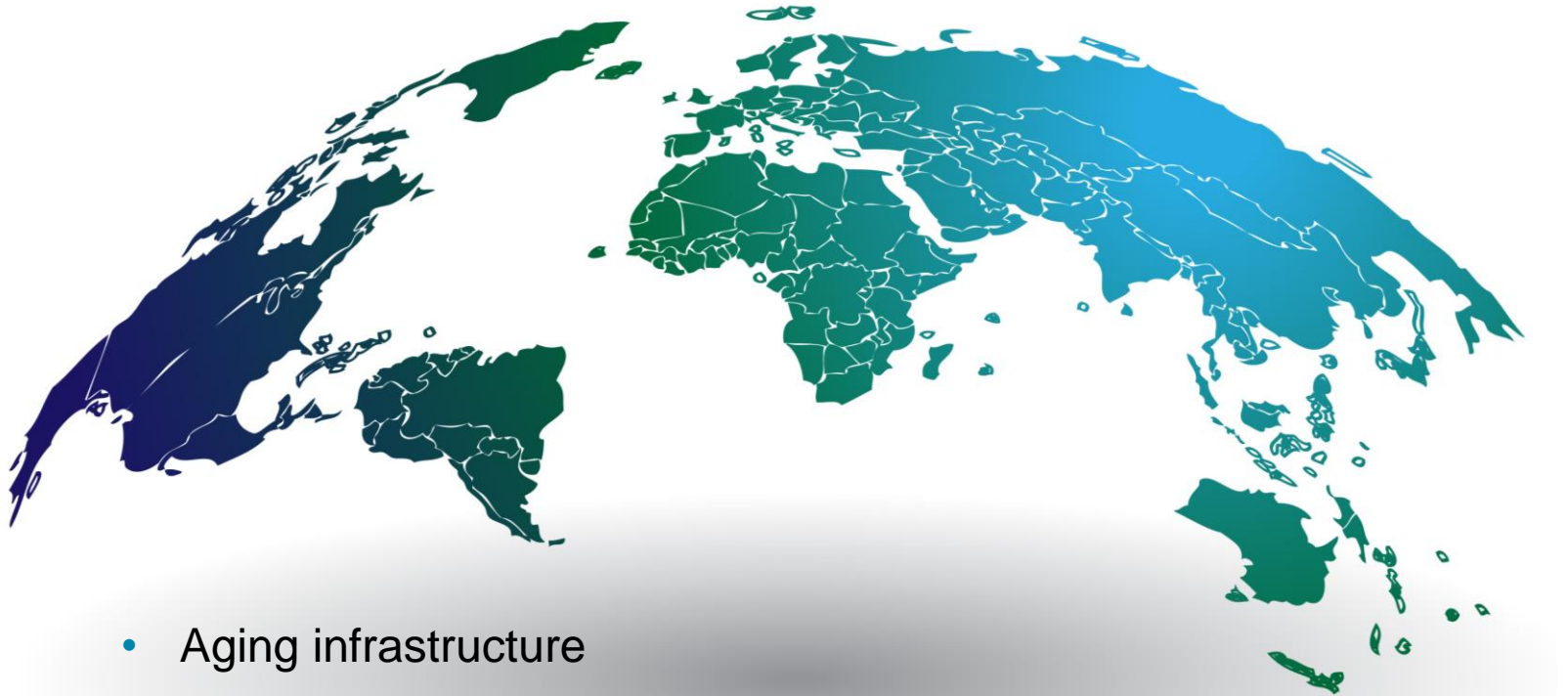

- Aging infrastructure
- Global urbanization
- Increasing energy costs
- Need for sustainable solutions

Macro trend: Software development



'In the future, every company will become a software company'



*Mark Andreessen Founder of Netscape
Venture Capitalist at Andreessen-Horowitz*

Pump User Challenges



Flygt Concertor™

The world's first
wastewater pumping
system with integrated
intelligence



FLYGT CONCERTOR iPS

EXTENDED
SCADA
Connectivity



Touch HMI Option



Webserver

NEW PANEL

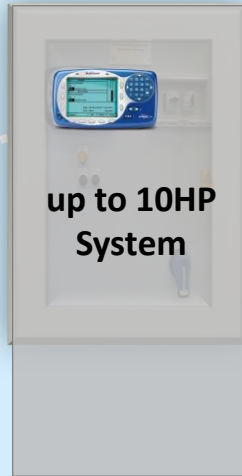

SS or Painted
SS Versions



Features

- ✓ Harmonised hydraulics and controls
- ✓ Adaptive N with hard iron impeller
- ✓ Advanced surge protection
- ✓ Set power
- ✓ Clog detection
- ✓ Pump cleaning
- ✓ Fault auto-reset
- ✓ Always correct rotation
- ✓ Power factor close to 1
- ✓ High efficiency IE4 motor
- ✓ Soft start
- ✓ Soft stop
- ✓ Energy minimiser
- ✓ Sump cleaning
- ✓ Pipe cleaning
- ✓ Automatic Concertor cooling

FLYGT
a xylem brand

Examples of built-in intelligence

Sump and pipe cleaning

Automatic adaption to different duty points

Self monitoring motor health

Energy minimizer function

Remote performance tune-up

Clog detection and pump cleaning

Always correct impeller rotation



State-of-the-art technology

Intelligent functionalities
based on over 100 years
of expertise

Remote control capability

Integrated control system

>IE4 Motor Efficiency

State-of-the-art N-hydraulic
efficiency and reliability

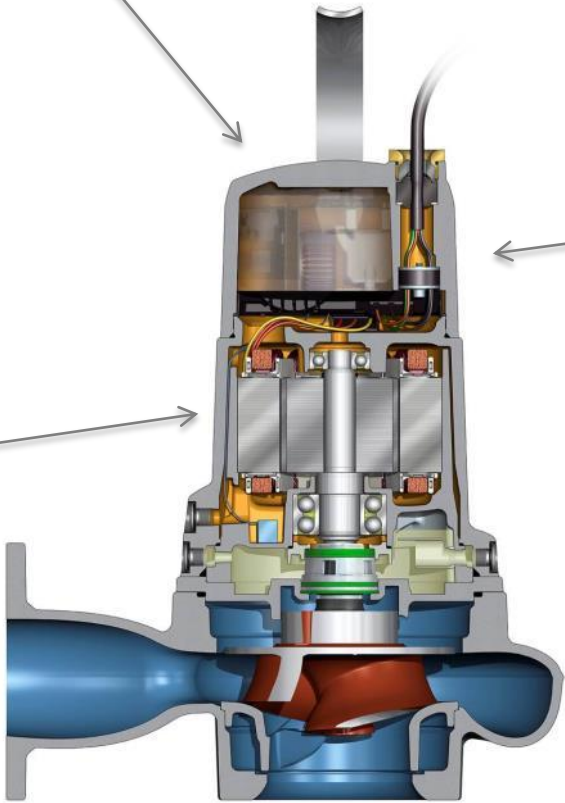

Integrated Drive Platform



Integrated Motor Control System



High Efficiency Motor



Dewatering
Pumps



Wastewater
Pumps



Mixers

Complete performance range 50-60 Hz

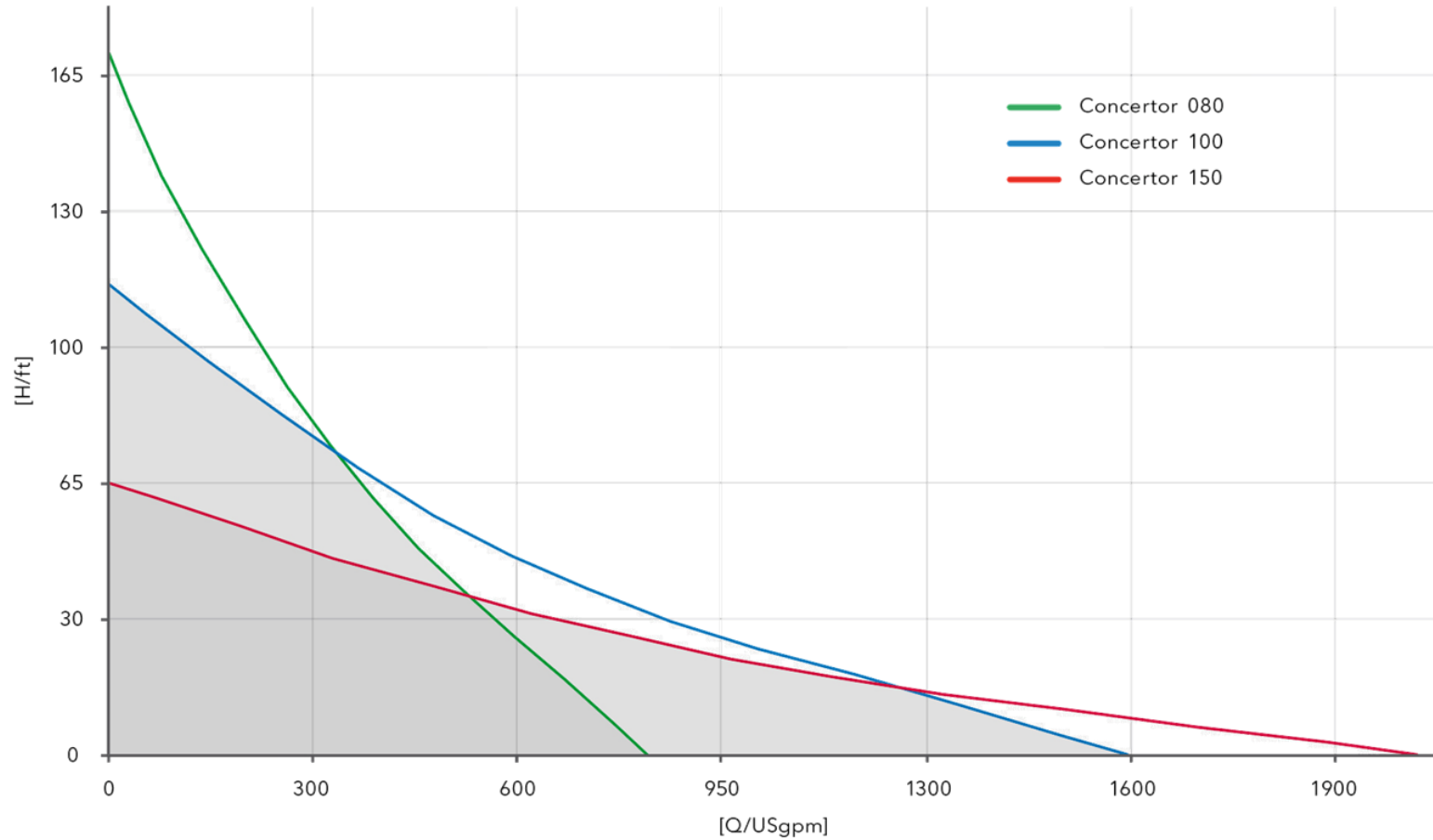

Key Values

**Efficient asset
management**

**Trouble free
pumping**

Energy Savings

**Reduced
Investment**



INVENTORY CAN BE REDUCED BY UP TO

80%

DUE TO **CONCERTOR'S FLEXIBLE PERFORMANCE**

Multiple Impellers and Trimming Eliminated

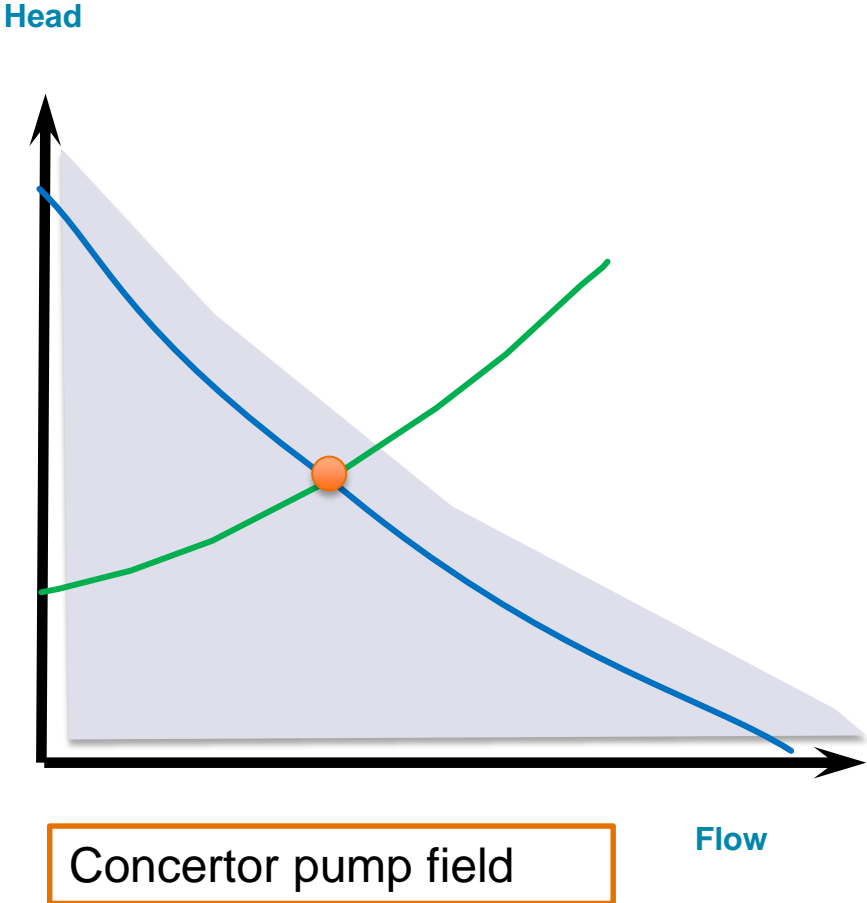
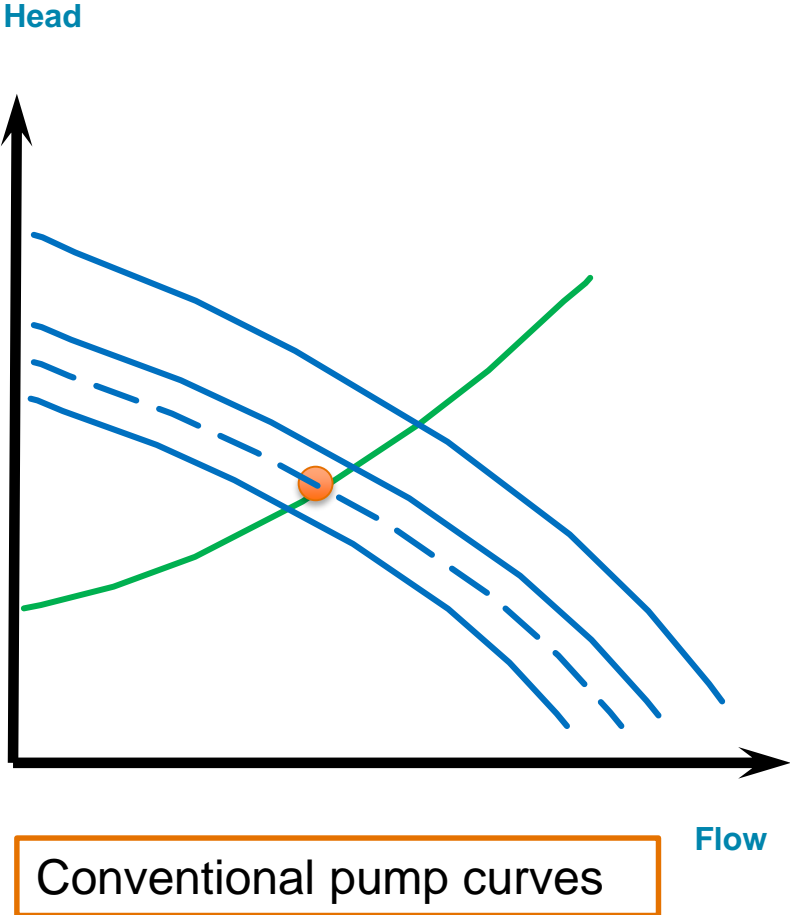

THAT WAS THEN...



Pump performance field

... THIS IS NOW

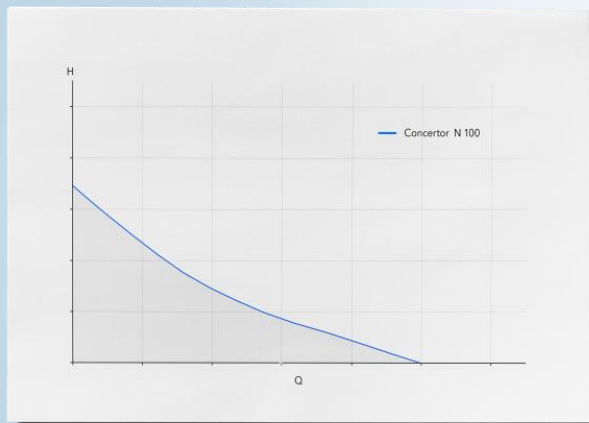

Duty Point Uncertainty

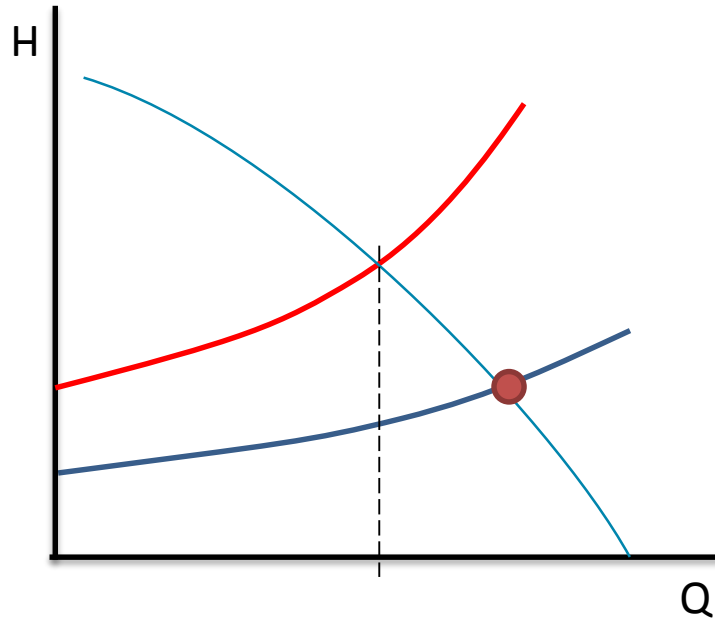

What is specified

What is experienced
at start up

- Factory tolerances of forcemain components
- Water levels as-built
- Theoretical vs. actual friction loss factors
 - Clean water vs wastewater
 - Pipe roughness
- Safety Factors in design calculations

Efficient asset management

THAT WAS THEN...

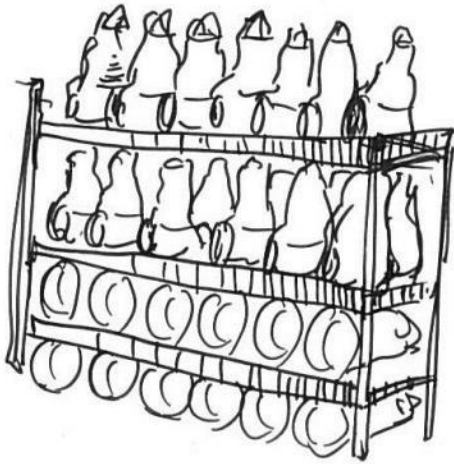

... THIS IS NOW

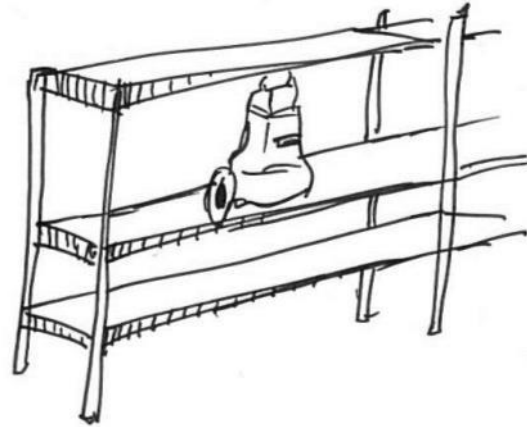

CLOG-FREE PUMPING OPERATION AND
CLEAN WET WELLS SAVE UP TO

80%

ON VACUUM **CLEANING COSTS**

From dirty troublemaker... to clean wet wells at all times

THAT WAS THEN...



... THIS IS NOW



Sump cleaning

- Varying shutoff levels and periodic pump-downs
- Adjustable frequency – typically every 12th cycle
- Clean wet wells & diminished grease ring
- Can reduce vacuum cleaning costs by as much as 80%

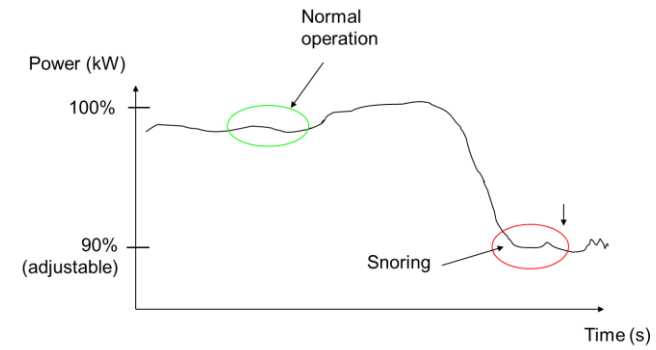

Before installing Concertor



After two weeks with Concertor

Pump cleaning



Thermal & Leakage Protection

- If heat detected in motor the motor automatically reduces its power to protect the pump
- Automatic restart if a drive trip occurs
- Proven leakage sensor is standard



Soft Start and Stop Protects System

Soft Start:

- Reduces start currents
- Less wear and tear

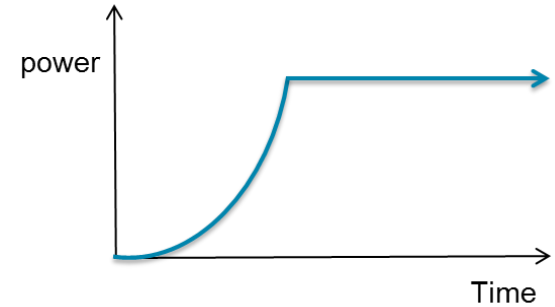
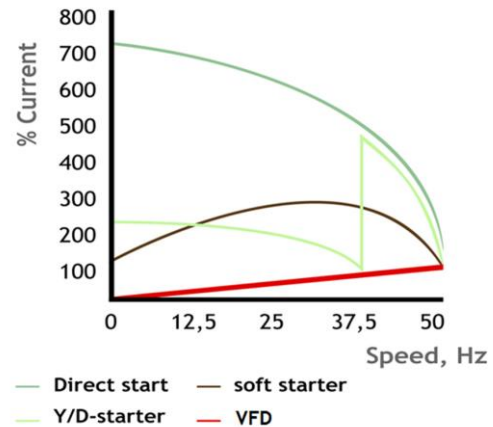

Soft Stop:

- Reduced slamming valves
- Less wear and tear
- Reduced water hammer effect
- Ramp down, then coast to stop

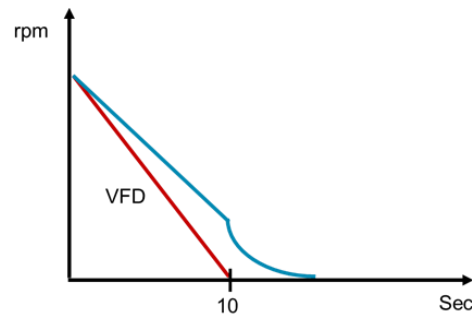

Pipe cleaning

Every 12th pump cycle the pipes are flushed



ENERGY SAVINGS OF UP TO

70%

COMPARED TO **CONVENTIONAL PUMPING** SYSTEMS

Increased Efficiency Built-In

- State-of-the-art synchronous motor
- IE4 super-premium efficiency level
- Adaptive N-hydraulics

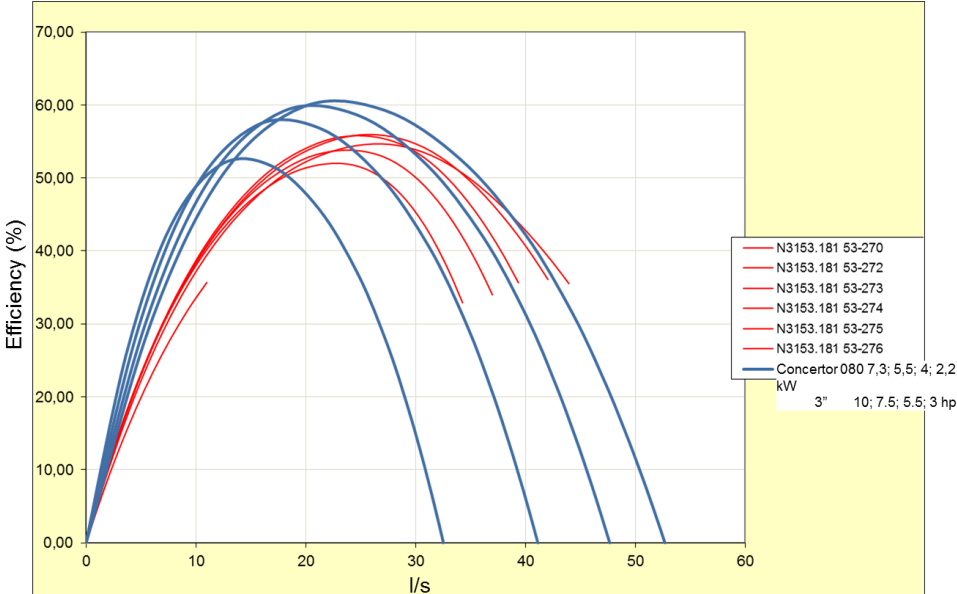
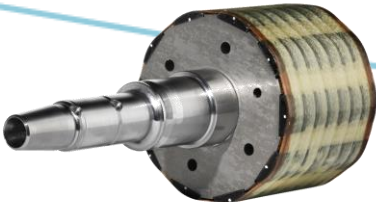

Energy minimizer (Patented)

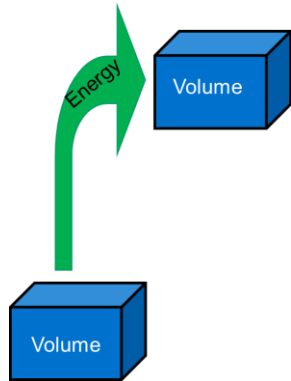
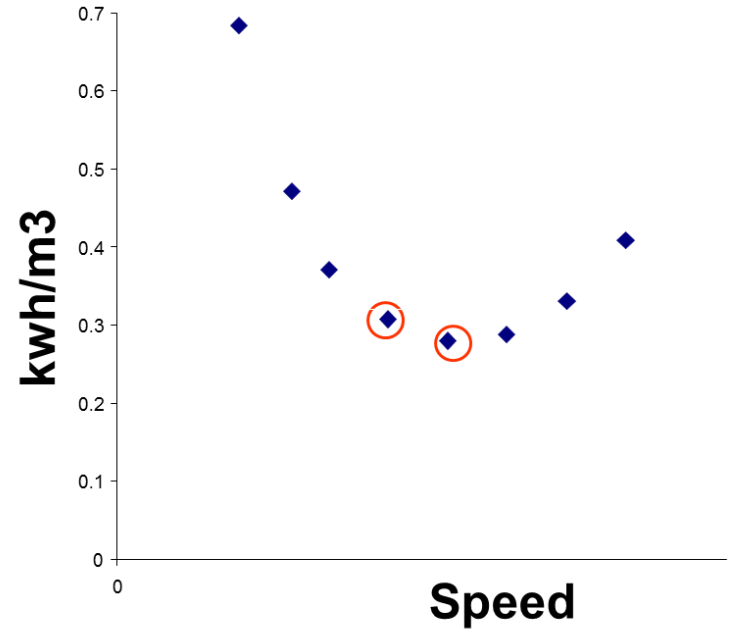
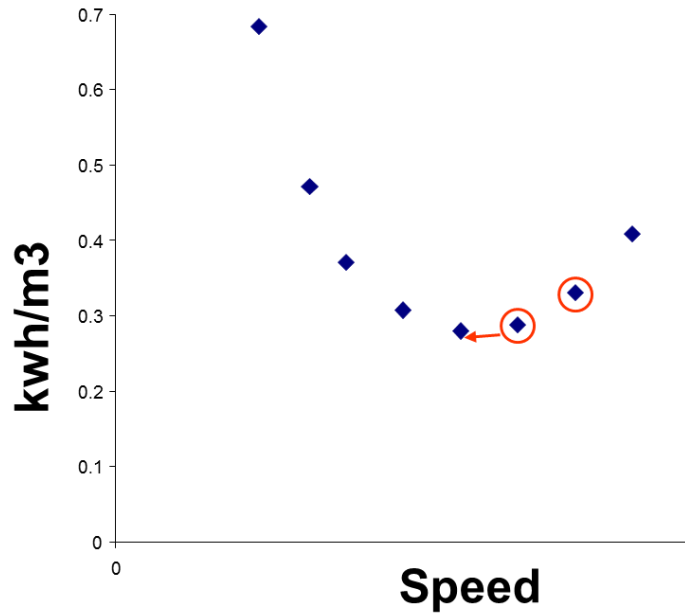

$$E_s = \frac{\text{Energy}}{\text{Volume}} \propto \frac{H}{\eta}$$

THAT WAS THEN...



... THIS IS NOW



Well proven in the field

Test installations around the world



- 📍 Wisconsin
- 📍 Washington
- 📍 Trino, Italy
- 📍 Fano, Italy
- 📍 Heathrow x2, UK
- 📍 Muscat, Oman
- 📍 Lomma, Sweden
- 📍 Louisiana
- 📍 North Dakota
- 📍 Pennsylvania
- 📍 Illinois
- 📍 Fröfjärden, Sweden
- 📍 Michigan
- 📍 New York
- 📍 Zagreb, Croatia
- 📍 Torenmolen, Netherlands
- 📍 Stavanger, Norway
- 📍 Zaragoza, Spain
- 📍 Voldum, Denmark
- 📍 UK
- 📍 Kungälv, Sweden
- 📍 Botkyrka, Sweden

Test Installations

	A	B	L	M	N	O	P	Q	R	S	Y	Z	AA	AB	AC	AD
	Name	EU/US	Name of Location	Installed	Replaced pump	Replaced kWh/day	Ivan kWh/day	Replaced kW	Concoror kW	Drive temp	Running days	Energy	Hours	Pump clean Jan11	Hivary/Hrepl	Saved energy
2	ARAGON	EU	Trino Vercelli, Italy	2015-09-09		12	3,7	1	29	150	1800	1800	97	49%	51%	
3	BALIN	EU	Fano, Italy	2015-09-02		70	42	5,9	2,6	43	150	6300	2423	55	67%	33%
4	BILBO	EU	Norway	2015-10-09			25		2	25	120	3000	1500	9		
5	BOROMIR	EU	Denmark	2015-11-06			29		2	17	90	2610	1305	102		
6	ELENDIL	EU	Heathrow	2015-09-25			4	5,9	1,8	15	120	480	267	88	53%	47%
7	ELROND	EU	Oman	2015-09-15			10	7,5	1	33	120	1200	1200	2	30%	70%
8	FARAMIR	EU	Lomma, Swe	2015-06-24		15	7	4	1,3	15	210	1470	1131	23	55%	45%
9	FRODO	EU	Holland	2015-09-23			24	5,9	2,4	21	120	2880	1200	139	64%	36%
10	GIMLI	US	Metairie, LA	2015-08-27			11	7,5	1,6	37	150	1650	1031	413	41%	59%
11	GOLLUM	US	Manchester,WA	2015-08-11			19	7,5	1,7	32	180	3420	2012	82	43%	57%
12	ISILDUR	US	Fond du Lac, WI	2015-07-21		11	4	3,7	2,4	17	180	720	300	29	87%	13%
13	MERRY	US	Fargo, ND	2015-08-13		80	38	7,5	1,5	34	180	6840	4560	86	40%	60%
14	PIPPIN	US	Chester, PA	2015-08-04			19	7,5	5	31	180	3420	684	243	89%	11%
15	ROSIE	US	Crystal Lake, IL	2015-07-20			18	7,5	1,8	29	180	3240	1800	4	45%	55%
16	SAM	EU	Fröfjärden, Swe	2015-06-04		13	6	5,9	1,4	17	240	1440	1029	63	45%	55%
17	SARUMAN	US	Lyon Township, MI	2015-07-22			0,4	7,5	2,1	18	180	72	34	0	50%	50%
18	TREEBEARD	US	Stony Brook, NY	2015-08-03			35	7,5	1,9	31	180	6300	3316	23	46%	54%
19	GANDALF	EU	Croatia	2016-01-14						15	10	100	50	50		
20											2740	46842	25591	1508		46%

Case Story - Heathrow Airport, UK

Pain Points

- Clogging issues with ragging
- High level of floating debris

Solution

- No clogs
- 87% savings in cleaning and servicing
- 53% energy savings

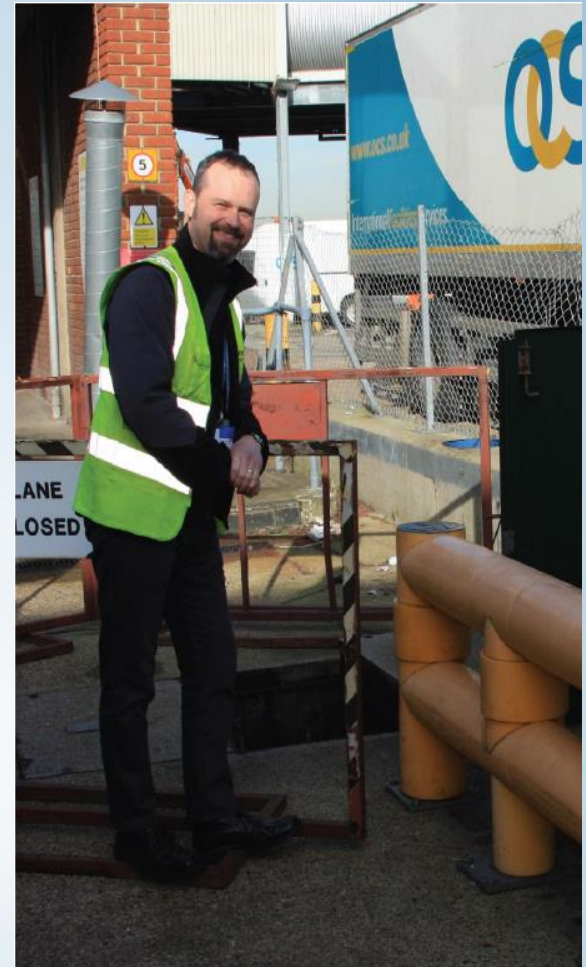

Case Story - Fond Du Lac, WI

Pain Points

- Clogging issues
- Station clean outs
- Energy costs
- Control panel size



Solution

- Clogs avoided with reverse rotation
- Cleaner station, no call outs
- Energy savings 5 HP reduced to 3 HP operation
- Smaller panel preferred for residential areas

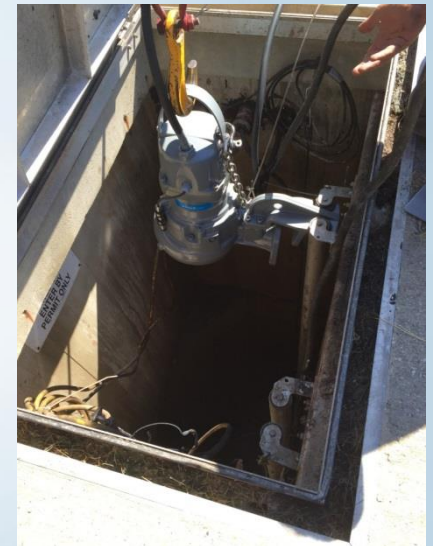

Case Story - Stony Brook, Suffolk County, NY

Pain Points

- Clogging issues due to extreme ragging
- Callouts approx. once every three months
- Change in demands on lift stations

Solution

- No need to check rotation at installation, quick installation
- Cleaner station, no call outs, saving \$4K annually
- Energy savings near 30%
- No need for ventilation in the panel, smaller size
- Cut down on pump inventory



Customer feedback

Pump cleaning, no cloggings

Sump cleaning, no cleaning trucks

Automatically adapts to best duty point and one pump fits all

Energy minimizer savings 40-50% or more

Enough to change one pump in a station



Questions?

Kristel Zaman

Flygt Product Marketing Manager
Xylem North America

Kristel.zaman@xyleminc.com

