

ZAX^{MASTER}9200i

AIR JET LOOM

DREAM NAVIGATOR
SINCE 1909

TSUDA  KOMA



ZAX^{MASTER}9200i AIR JET LOOM

Balanced high productivity, value-addition,
and energy saving at a high level

Higher speed operation and extensive reduction in electrical and air consumption

Higher Speed

Outstanding features for ultra high-speed and low vibration

High speed operation is the essential asset of air jet looms.

In addition to stable operation at high speeds, faster than the ZAX9100, the ZAX9200i has low vibration and saves electricity.

■ Soft weft insertion at high speed

Proven benefit based on actual operation. A 4-link beating motion that works excellently at ultra-high speed is used for narrow looms. A 6-link beating motion with more time allowance for weft insertion is used for wider looms, thus achieving more stable weft insertion.

■ Reduced floor vibration

Using CAE analysis, Tsudakoma designed a new robust frame structure. By employing the offset rocking shaft with less moment of inertia and a hollow reed holder, beating is well-balanced. Floor vibration can be reduced.

■ Clear shedding

The beating stroke is shortened and the driving parts that are the most essential for the weaving machine to run at high speed are additionally reinforced. By placing the heald frame as close to the cloth fell as possible while keeping the shedding amount, the shedding angle is increased and defective shedding is reduced. Due to this, stable operation at high speed is attained compared with our conventional model.

Tsudakoma's optimized designs for the beating stroke and heald frame operation together with improved mechanical elements achieve 5% or more reduction in electrical consumption.

(Compared with the ZAX9100)

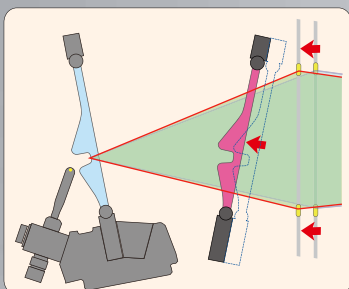

Energy Conservation

i-Weave

With the "i-Weave," provided as standard for the ZAX9200i, high-speed performance is accompanied with energy saving by optimizing the three basics of weft insertion for air jet looms: nozzle, valve, and control technology.

With a variety of optional devices, higher-grade performance is available.

The "i-Weave" is the fruit of weft insertion technology backed by Tsudakoma's 40-year accumulated air jet knowledge and our sales success.



Smart

Robust frame structure

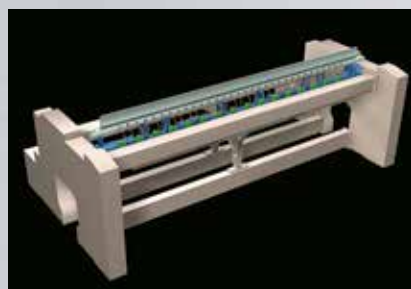

Hollow reed holder

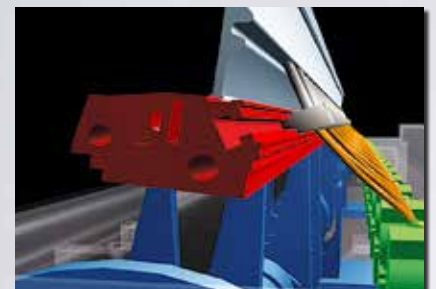

Smart Ecology

Ecology and Economy in Harmony

The "ZAX9200i MASTER" upgrades the high-speed ability of Tsudakoma's best-selling air jet loom the "ZAX9100 Professional."

The ZAX9200i saves resources, energy, and manpower. It is an advanced air jet loom that is worthy of the name "MASTER." Newly upgraded electric components strongly support the "ZAX9200i MASTER."

Quality Fabric

i-Start

The best start method for a fabric, the best compensation for the warp tension according to stop marks, and the ELO & the ETU control can be selected.

Fell control under various setting conditions is possible. High quality fabric is assured by easy operation of the graphic interface.

Ultimate weaving support!

Ultimate weaving support! "Weave Navigation® System-II"

The world's first weaving support system that Tsudakoma developed is upgraded to the "Weave Navigation® System-II." The "Weave Navigation® System-II" employs a 15-inch display - the largest in the weaving machine field. It reduces the hierarchy levels of the menu and the number of button operations is also reduced for user-friendliness. Multi-windows are supported. They allow real-time adjustments while observing the result. Due to the optimum weaving conditions, high quality fabrics are produced while saving energy at a high level.

Wider Versatility

Expanding the world of air jet weaving

The ZAX9200i can run with various shedding motions. With its robust let-off and take-up, it can weave high-density and high-tension fabrics. The ZAX9200i can also weave a maximum of 8 colors while achieving stable operation and quality improvement for fabrics using thick yarns due to its twin auxiliary main nozzles. With a wealth of optional devices such as the EPL Electronic Planetary Leno motion, it is flexible and produces advanced quality fabrics. The ZAX9200i can weave a wider range of fabrics.

Ecology

Harmony with the Environment

Aiming for eco-friendly looms

In addition to low vibration and energy saving, Tsudakoma aims to harmonize with the environment. We continue investigating noise and vibration reductions, and promote practical applications.

The new smart air grid function combined with an air compressor can reduce the energy costs for the whole weaving mill beyond a single loom.

Twin nozzle valve

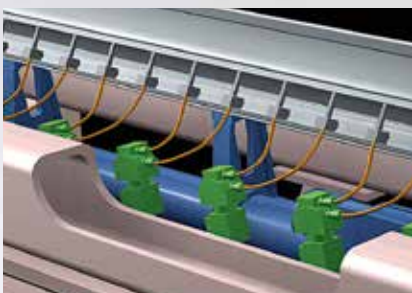

Offset rocking shaft



ZAX9200i MASTER

Energy Conservation

Advanced energy-saving

The ZAX9200i is compatible with the conflicting tasks of ultra high-speed, low vibration, and energy saving.

i-Weave

The "i-Weave" optimizes the three basics of weft insertion for air jet looms: nozzle, valve, and control technology. High-speed performance is accompanied with energy saving. The "i-Weave" is standard on the ZAX9200i. The "i-Weave" is the fruit of weft insertion technology backed by Tsudakoma's 40-year development and sales success on air jet looms.

■ AJC-S Auto Jet Control

The ZAX9200i is equipped with the air mode (patent-pending) to reduce air consumption enabling easy setting for energy saving. By controlling nozzle jetting timing in response to actual weft insertion, air saving is combined with stable operation.

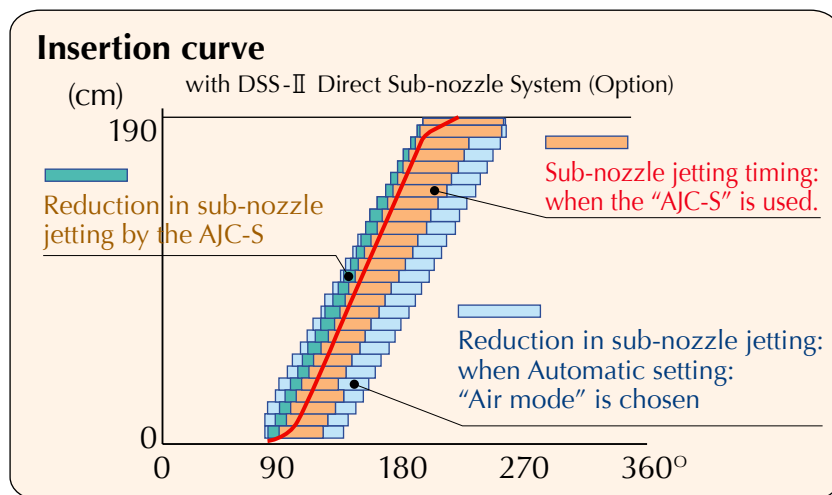

■ Adjustable guide bar Option

No need to cut the guide bar according to the reeding width. Provided with the mechanism which can adjust its length, the time required for style changes is greatly reduced. The adjustable guide bar is in the reed air guide and supports the cloth fell leading to stable operation. (Patent-pending)

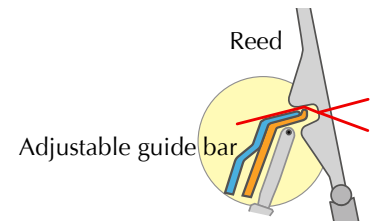
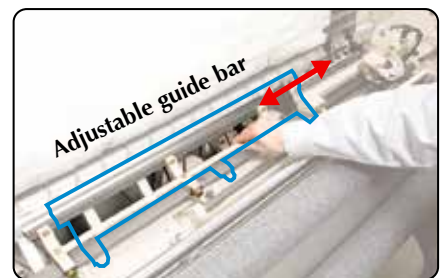

■ Switchable sub-nozzle block

By placing the sub-nozzles close to the weft, lower air pressure for weft insertion can be used so air consumption is reduced. The lower air pressure also reduces damage to the weft.

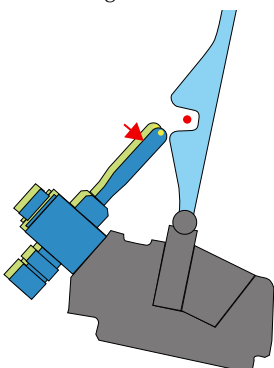

■ DSS-II Direct Sub-nozzle System Option

By employing an efficient new valve and optimizing the piping from the manifold, low setting pressure is accomplished while saving air.

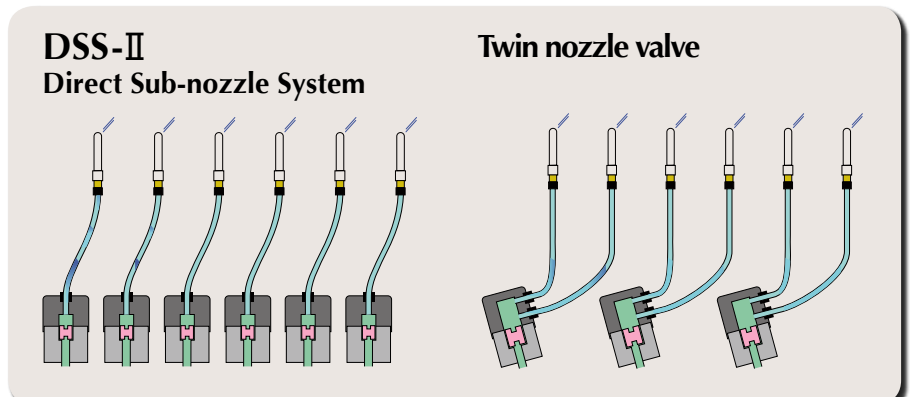

Easy Operation & Maintenance

Advanced New Electronic Components

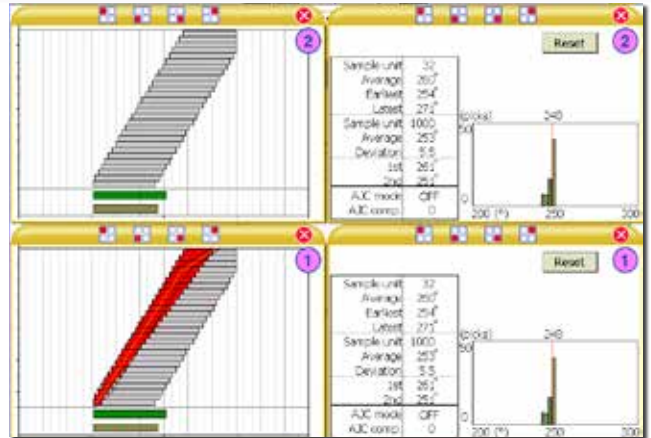

■ New Navi-board

The high-resolution LCD monitor that reproduces 16 million colors provides a maintenance guide on video and allows adjustments based on visual cues.

The 15-inch display reduces the hierarchy levels of the menu and the number of button operations is also reduced for user-friendliness.

■ Reliable design

Long-lived parts are used for the control printed board. The layout of the electric components is optimized.

■ i-Start

In addition to the conventional kickback function that controls the cloth fell just before the loom starts, compensating the let-off and take-up speeds just after the loom starts makes stop marks less prominent.

A new function is added: By changing the warp tension that was decreased during loom stop back to the tension just before the loom starts, stop marks caused by a decrease in warp tension can be eliminated.

■ Automation

Adjustments for the 1st pick timing are no longer necessary. The timing of the main nozzle and the hook pin for the 1st pick is automatically controlled in response to the initial rise of the motor when the loom is started. When the loom RPM changes while using the same weft type, weft insertion adjustments for the low and high speeds are not required either.

■ Energy saving

Power consumption for control except for the driving motor is reduced by about 20%.

■ Use of USB thumb drive

Loom data can be saved and transported with a special USB thumb drive.

The amount of data saved is drastically increased. Data management is easy.

■ ACI

Air Consumption Indicator

By indicating air consumption per loom, abnormal settings can be easily found on the Navi-board.

■ Multi-windows

Simultaneously displaying the setting page and the monitoring page allow real-time adjustments. You can adjust the weft insertion timing while observing the weft insertion graph, and can set the warp tension while observing the tension changes.

■ Wider versatility

The number of steps of the weaving pattern data is increased to 19,980,000 picks including the repeat function for the dobby loom, and to 1,980,000 picks for the cam/crank shedding loom. The available number of pick densities is also increased to 32. Therefore, various fabrics can be woven.

■ Stand-alone display

Even when the LAN environment for the TLM is not provided, the manuals and the parts catalog can be displayed by the stand-alone loom.

■ Video replay

Procedures for adjustments and maintenance can be checked through the video. The required works are easily comprehensible.





Ultimate weaving support!

Weave Navigation® System-II

The weaving support system that Tsudakoma developed before the rest of the world is upgraded to the very user-friendly “Weave Navigation® System-II.” The loom itself leads to the optimum weaving conditions for a wide variety of fabrics.

Weave Navi®

The Weave Navigation® monitors loom operation while the loom is in operation. It gives advice to improve the operation in various situations, navigating you to the best weaving possible.



Tune Navigation

The best setting values are automatically entered for your fabric and loom specifications. Optimum mechanical settings are recommended for the tension roll position, easing amount, and various pressure settings according to the fabrics to be woven.

Warp		Filling		Mechanical Navigation	
1. Tread pos. height	NO.14-30	libed amount	60	Headhgr	140
2. Easing timing	370	2-P	66	140	140
3. Connecting position	Bottom	2-P	66	140	140
4. Easing amount	4.3	2-P	66	140	140
5. Easing spring dia.	-	2-P	66	140	140
6. Shedding Spring 1	200	2-P	66	140	140
7. Shedding Spring 2	-	2-P	66	140	140
8. Dropper Position	-	2-P	66	140	140
9. Dropper S & F	40	2-P	66	140	140
10. Dropper height	25	2-P	66	140	140
11. Temple	-	2-P	66	140	140

Weave Tips

We provide weaving expertise according to the fabric.

Warp	Filling	Mechanical Navigation
Total quantity: 22000 ends	Thickens: 20.0	Shed: auto
Warping: 20.0	Grain: 50.0 (pitch)	For let & hold in: Grainwise
Warping: 1/3	Warping dia.: 80.0 (mm)	Warping dia.: 80.0 (mm)
Type: Cotton	Warping with: 30.0 (mm)	Shed roll height: 200 (mm)
	Clash name: auto	

Filling type	Thickens	IPC mode	Turn pick
C3: Cotton	20.0	2: PDP sensor -Start	3
C2: Cotton	20.0	2: PDP sensor -Start	3
C4: Cotton	20.0	2: PDP sensor -Start	3
C1: Cotton	20.0	2: PDP sensor -Start	3

Warping with	S&F2 (mm (mm))	Number of rollers (pc)	Shed Lash
30.0 (mm)	1-7 80	4	without
40.0 (mm)	6 80	4	with
50.0 (mm)	8 80	4	without
60.0 (mm)	10 80	4	with

- FABRIC WITH TUCK-IN SELVAGE
- DYED YARN FABRIC
- ELEMENT (W) (NYLON) & SPIN (D) FABRIC
- STRETCH YARN FABRIC
- DENIM
- ELEMENT HIGH-TWIST YARN

In addition to pursuing high speed and high quality, Tsudakoma holds the concept of the “Weave Navigator” leading to higher user satisfaction by providing our accumulated wealth of weaving expertise.

Trace Navigation

When solving a problem like a stop mark, which needs to adjust multiple setting items, operators need only to adjust one setting to change all the related set values to the optimum based on Tsudakoma’s accumulated weaving experience.

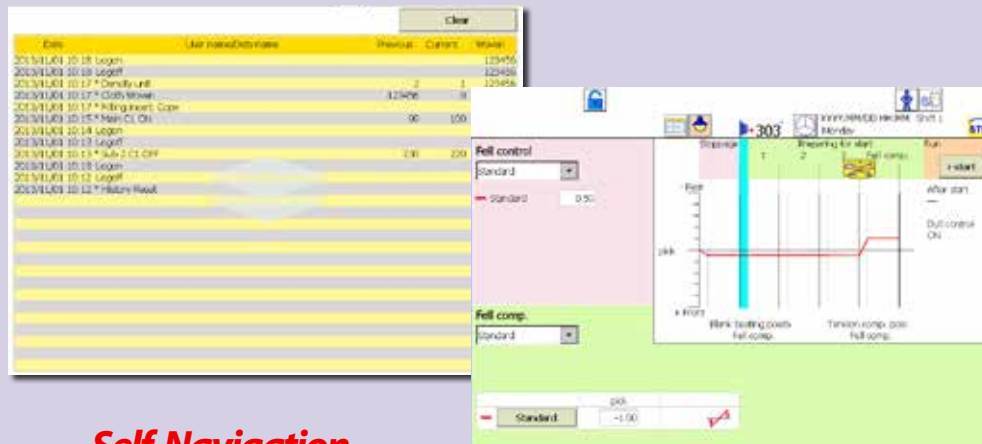

Self Navigation

Excellent self-diagnosis and maintenance information help maintenance work. Weft insertion adjustment does not need measuring equipment.

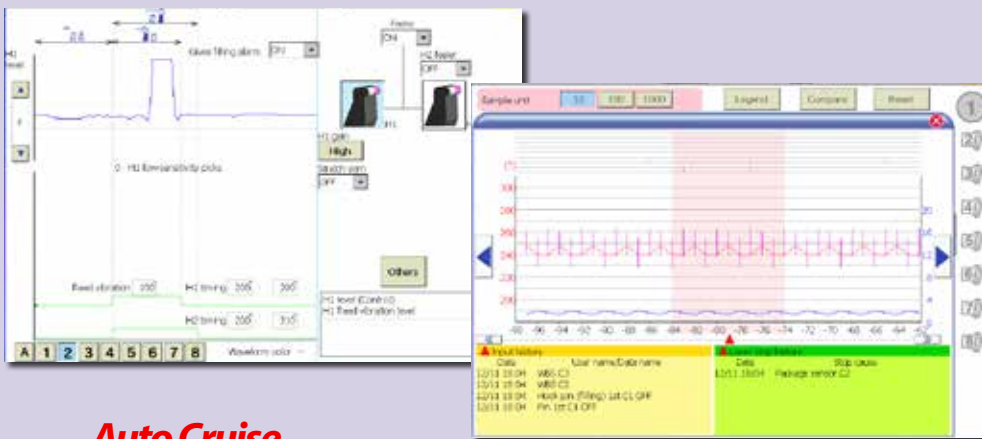

Auto Cruise

Automatic adjustments for the loom’s setting according to the ever-changing weft insertion status provide you with a comfortable auto cruise in weaving.

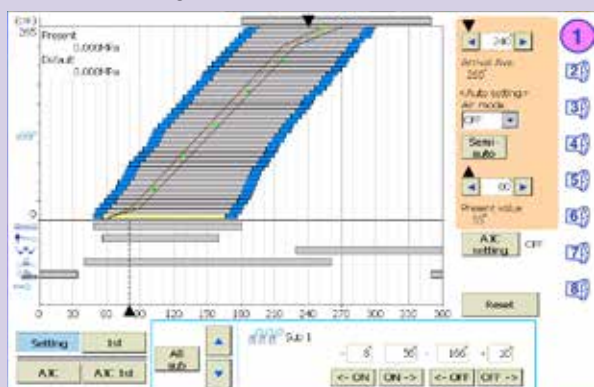

Easy maintenance

On the Navi-board, the ZAX9200i with the Weave Navigation® System displays information about maintenance, such as the position and parts for periodic replacement.

TLM Tsudakoma Loom Monitoring system

As well as monitoring operation of the looms, bi-directional communication supports loom-to-loom setting data transfer and dobby pattern data transfer. You can accurately accumulate your own weaving know-how because the loom adjustment data and mechanical settings are controlled by the host computer according to the fabric.

Smart Air Grid Option

Information about air pressure and air consumption is sent to the compressor through the TLM. The new Smart Air Grid function combined with an air compressor can reduce the energy costs for an entire weaving mill. The Smart Air Grid is a new concept designed by Tsudakoma to reduce air consumption.

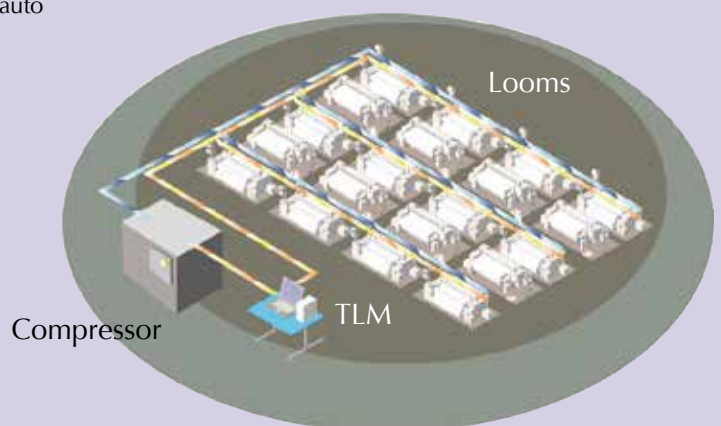

ZAX9200i

Wider Versatility

Expanding the world of air jet weaving

8-color weft selection (Option)

The FDP-AIII free drum pooling system is superior in responding to high-speeds. Its advancing reel system separates weft yarns positively and is useful in weaving even long hairy yarns like worsted yarns without difficulty. The ZAX9200i can weave a much wider range of wefts.

It stabilizes insertion with less yarn breakage even at high-speed weaving or extra-wide weaving.

Optional weft selection up to 8 colors is available.



WBS Weft Brake System (Option)

The WBS sharply reduces the peak tension that occurs at the end of weft insertion in order to prevent weft breakage and looseness. This system is best for extra-wide weaving which invites higher peak tension. It is also helpful for yarns which may cause broken picks. Tsudakoma's unique pullback function equipped with the WBS system reduces tip troubles drastically. The WBS contributes to stable high-speed operation and fabric quality. Automatic setting is available through the Navi-board.

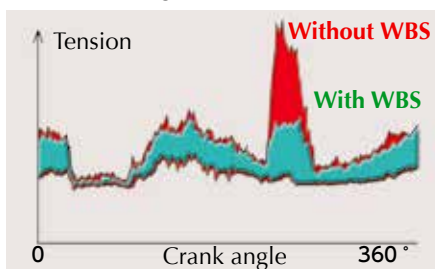

CCL Catch Cord-Less (Option)

The weft entered in the stretch nozzle is caught and held by an ejector mouth and is cut by a selvage cutter for several picks. Catch cords are not required, reducing consumption in resources. No problems about catch cords occur and operability improves.

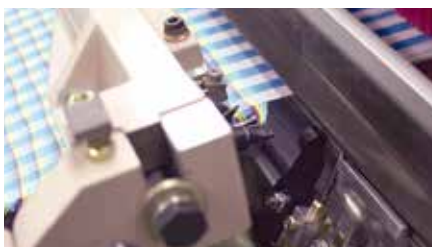

3-eyed feeler (Option)

The 3-eyed feeler, a reflective sensor, detects any colored spun and filament yarns ensuring stable weft insertion. This feeler does not require a special reed for each reeding width.

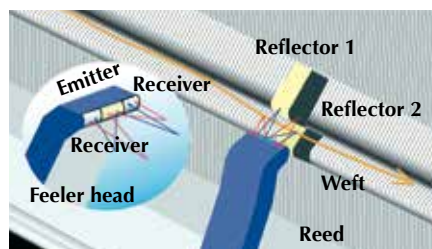

i-WBS Weft Brake System (Option)

By adjusting the braking force to the weft according to weft insertion conditions, energy saving is attained and broken picks are reduced. Stable weft insertion contributes to high efficiency and quality fabric weaving.

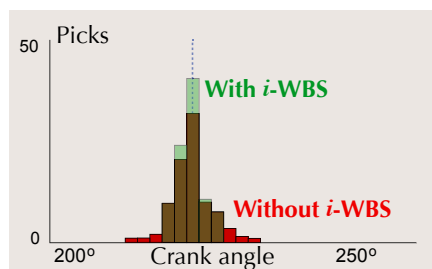

PSC Programmable Speed Control (Option)

Up to 32 kinds of loom RPM can be independently set. Formerly the loom RPM was restricted in case of difficult weft yarns. The PSC automatically adjusts the RPM to the optimum for each yarn kind. Thus, productivity is dramatically increased. The loom RPM is changed within one pick.

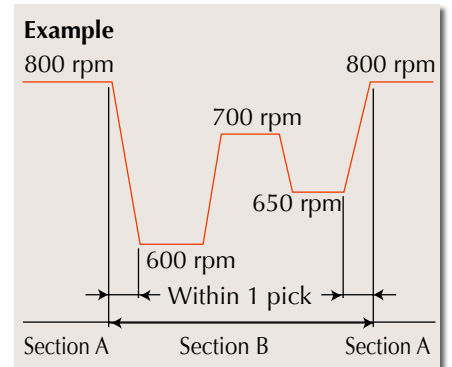

APR-III Automatic defective Pick Remover (Option)

Adoption of a mechanical sensor enhances accuracy to detect a defective pick when using color yarns. Its compact design makes great improvements in operability for warp repair.

The removed defective yarn is discharged to the trash box. Later collection is easy.



The ZAX9200i can run with various kinds of shedding motions. With a wealth of optional devices in addition to its full basic performance as a loom, the ZAX9200i can weave a wide range of fabrics using multi-colors, high-density, high-tension, or fancy yarn.

■ ZTN Needle-less Tuck-in device (Option)

Wefts are tucked in the edge by air, instead of a tuck-in needle. Adjustment can be done without interference between the reed and a tuck-in needle. Less wear and few mechanical failures are expected allowing high speed operation. Maintenance is easy, too. The tuck-in device can be adjusted by entering values on the Navi-board. Fine tucked selvage can be formed easily.



■ ZT Tuck-in device (Option)



■ EIS Electronic Independent Selvage motion (Option)

There are fewer consumable parts than the conventional mechanical motion. High speed is available. The shedding amount, the shedding timing, and the shedding pattern can be set on the Navi-board. The EIS is user-friendly and versatility increases. (Patented)



■ New TSC Tsudakoma Style Change system (Option)

A carrier common to looms and a preparatory machine is used in order not only to shorten the downtime of looms but to reduce and streamline man-hours of the whole plant. Employing the special DH unit that is a special module unitizing droppers, heald frames, and a reed drastically shorten the time required for their delivery to a loom.

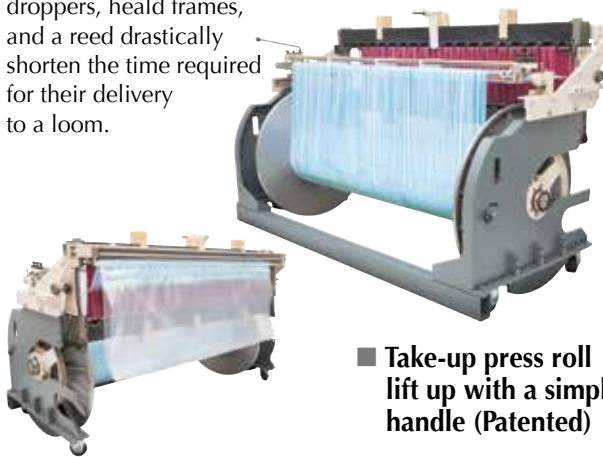

■ Take-up press roll lift up with a simple handle (Patented)

■ EPL Electronic Planetary Leno motion (Option)

The planetary leno selvage motion is driven by the exclusive servo motors that are independent on the right and left. The shedding timing and the rotating direction of the planetary gears can be set on the Navi-board. Free positioning of the bobbins during maintenance improves operations.



■ Pressure regulators arranged at a higher position



■ 6-link crank shedding (Option)

By increasing the number of links from four to six, a dwell angle is given for lower shedding.

Due to this, there is a tension difference between the upper and lower warp sheets at beating.

Higher pick density is realized compared to the 4-link crank shedding.

Weaving range is expanded from poplin to broadcloth.

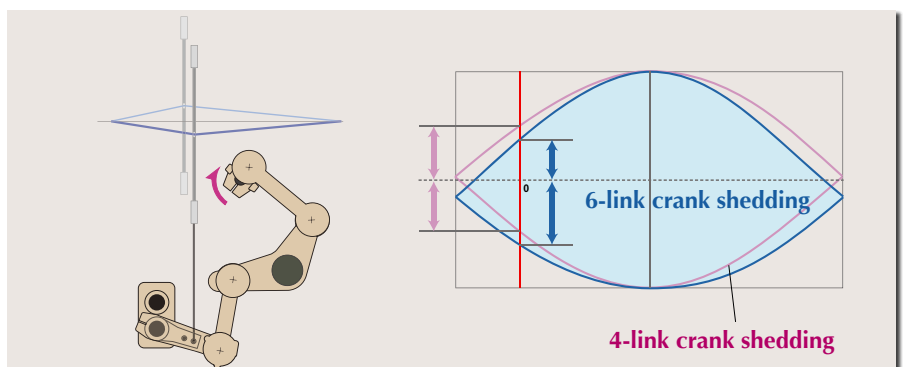

ZAX9200i

Specifications

Item	Specification	Option	
Reed space	Nominal (cm)	150, 170, 190, 210, 230, 250, 280, 340, 360, 390	
	Useful Reeding width	Same as nominal width. Maximum reduction: 60 cm (for 250 cm or narrower loom) 80 cm (for 280 cm or wider loom)	Maximum reduction: 80 cm (for 190 ~ 250 cm)
Weavable range	Spun: Ne 100 ~ Ne 2.5 Filament: 22 dtex ~ 1350 dtex		
Weft selection	2 Colors, 4 Colors, 6 Colors	8 Colors	
Driving	Starting method	Direct start of rush-start motor drive <i>i</i> -Start Push-button operation with both hands Slow inching with an inverter (Forward, reverse)	PSC Programable Speed Control Built-in type speed control inverter
	Motor capacity	2.7kw, 3.0kw, 3.7kw, 5.5kw	
Weft insertion		Main and sub-nozzles combined system Auxiliary main nozzle, Stretch nozzle	Twin auxiliary main nozzles
	Weft insertion control	<i>i</i> -Weave • AJC-S Auto Jet Control • Switchable sub-nozzle block • ACI Air Consumption Indicator First pick control Solenoid valve with built-in manifolds (Two sub-nozzles/valve) Independent sub-nozzle timing control by color Sub-nozzle boosting system Independent auxiliary main nozzle timing control	<i>i</i> -WBS Weft Brake System WBS Weft Brake System FIC Fuzzy Insertion Control Main nozzle clamber Main nozzle for core spun yarn DSS-II Direct Sub-nozzle System
	Measuring & storage	FDP-AⅢ Free Drum Pooling (With advancing reel system)	Balloon breaker
Shedding	Crank shedding: 4 shafts Positive cam shedding: Up to 8 shafts Positive dobby shedding (Electronic, Floor-mounted): Up to 16 shafts Jacquard shedding	Negative cam shedding: Up to 8 shafts Auto-leveling (Positive cam) Positive cam shedding: Up to 10 shafts ESS Electronic Shedding System: Up to 16 shafts Selvage-name Jacquard 6-link crank shedding EIS Electronic Independent Selvage motion 2/2 selvage motion	
Let-off		ELO Electronic Let-Off (with kickback function) Double roll system with positive easing motion	Twin beam, Double beam
	Flange diameter	800mm, 914mm, 1000mm, 1100mm	
Take-up		ETU Electronic Take-up, with automatic density change function (32 densities)	
	Maximum on-loom take-up diameter	600 mm (Cam, dobby, Jacquard shedding), 520 mm (Crank shedding)	720 mm Off-loom take-up device
	Pick density	5.9 ~ 118.1 picks/cm (15 ~ 300 picks/inch)	
	Woven length counter	Display on Navi-board (meter, yard, pick), with preset counter function	
	Temple	Top-mounted type Take-up press roll lift up with a simple handle operation	Adjustable guide bar
Beating		Crank type beating, multiple sley sword beating: 4 links (Reed space up to 230 cm) 6 links (Reed space 250 cm or more)	
		Offset rocking shaft with intermediate supporter	
Weft supply stand	Floor mounted for 4 packages (2 colors), Floor mounted for 8 packages (4 colors), Floor mounted for 10 packages (6 colors)		
Selvage formation	Planetary leno motion	EPL Electronic Planetary Leno motion ZTN Needle-less Tuck-in device (Left & right, intermediate) ZT Tuck-in device (Left & right, intermediate) Center leno	
Waste weft removal	Catch-cord type (2-roll type), catch cord type (Gear type)	Independent shedding motion for catch cord	
Cutter	Mechanical cutter	Electrical cutter	
Lubrication	Oil bath system for main driving parts, centralized lubrication (Manual grease)	Centralized lubrication (Automatic grease)	
Stop motion	Weft yarn	Reflective weft feeler One-head system, two-head system	Package sensor, pigtail sensor 3-eyed feeler
	Warp yarn	Electric 6-row contact bar system	Row number indication function, left & right area indication function
	Others	Stop motion for selvage and catch cord yarn	SGS Safety Guard Sensor
	Stop cause indication	Indication by message on Navi-board 4-color multi-function indication lamps	
Weave Navigation® System-II	Navi-board	Automatic data setting, recommended setting indication, optimum weaving condition information Automatic control, troubleshooting, self-diagnosis function Operating data indication, maintenance data indication, weaving advice, operation manual & parts catalog browse	
	Network application	TLM Tsudakoma Loom Monitoring system	
Automation		APR-Ⅲ Automatic defective Pick Remover New TSC Tsudakoma Style Change system	

■ Dimensions

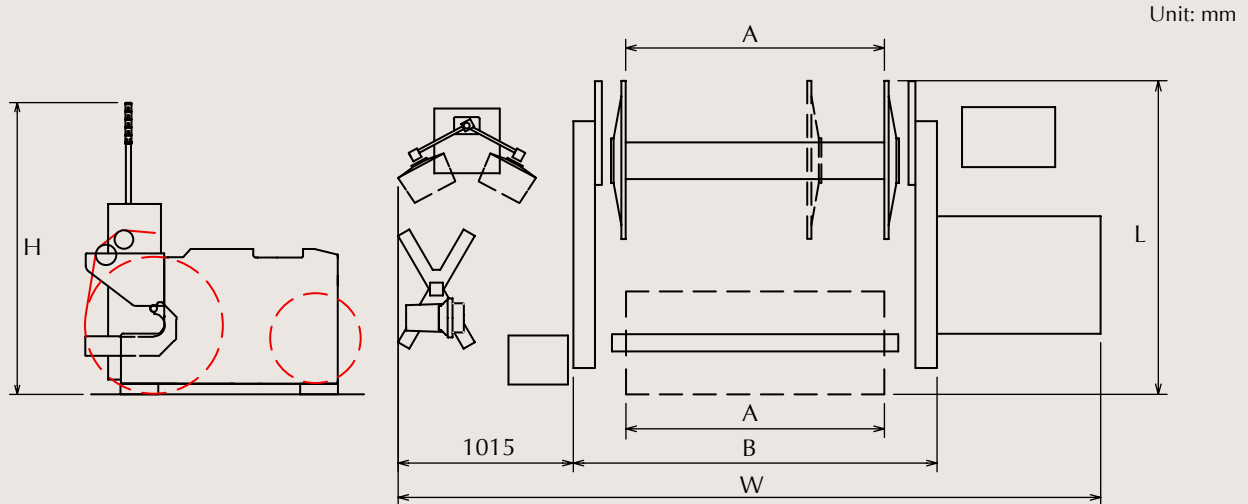

	Flange diameter	Crank, Cam	Dobby
L	800	1,762	1,882
	914	1,828	1,948
	1,000	1,894	2,014
H		2,014	
L	1,100	2,016	2,136
H		2,056	

Reed space (cm)		150	170	190	210	230	250	280	340	360	390
W	Crank shedding (3.0kW)	3,810	4,010	4,210	4,410	4,610	4,810	5,110	5,710	5,910	6,210
	Positive cam	4,085	4,285	4,485	4,685	4,885	5,085	5,385	5,985	6,185	6,485
	Floor-mounted positive dobbie	4,239	4,439	4,639	4,839	5,039	5,239	5,539	6,139	6,339	6,639
A		1,500	1,700	1,900	2,100	2,300	2,500	2,800	3,400	3,600	3,900
B		2,110	2,310	2,510	2,710	2,910	3,110	3,410	4,010	4,210	4,510

Note 1: For details of other specifications, please ask Tsudakoma.

Note 2: When the flange diameter is 914 mm or more, liners are required.

Note 3: Figures in the "W" section are the dimensions for a 2-color loom with the i-WBS or for a 4-color loom. For other specifications, please ask Tsudakoma.

Note 4: Photographs, drawings and data in this brochure are subject to change for improvement without notice.

Note 5: Photos in this brochure partially include optional equipment.

Strong support for air jet loom operations

T-Tech Japan Corp.'s preparatory machines, including the sizing machines, are top-level performers and the best-quality. They are ready for the fast-changing market demands in preparatory machines. They also help improve the quality and operations of the weaving process.

The "TTS10S & TTS20S Spun Sizing Machines" provide easy operation and even-sized yarns due to the vertical pulling system. With the "Sizing Navigation System," operability, operation controls, and quality controls are considered. The detailed controls achieve superior energy-saving while significantly contributing to the best weaving conditions of looms.

It has the largest market share in the world in filament sizing machines. The "TSE30F Filament Sizing Machine" attains stable tension control from the lowest 20 N to the highest 800 N to satisfy market demands.



TTS20S SPUN SIZING MACHINE



TSE30F FILAMENT SIZING MACHINE



DREAM NAVIGATOR
SINCE 1909

TSUDA  KOMA

Since its founding in 1909, Tsudakoma has been a vigorous pioneer in weaving technology.

While achieving higher productivity,
improving fabric quality,
and saving energy,
Tsudakoma has poured its energy into satisfying
the demands of multi-colored,
wide, and value-added fabrics.
As a result, Tsudakoma is the leader in
cutting-edge weaving technology.

Tsudakoma, as the Dream Navigator, continues creating
excellent textile machinery, opening the door
to a new era of weaving.

TSUDAKOMA Corp.
www.tsudakoma.co.jp
18-18, Nomachi 5-chome, Kanazawa, 921-8650, Japan

ISO 9001
14001

A02ZVB02TE