

SEPARATOR R-120LA

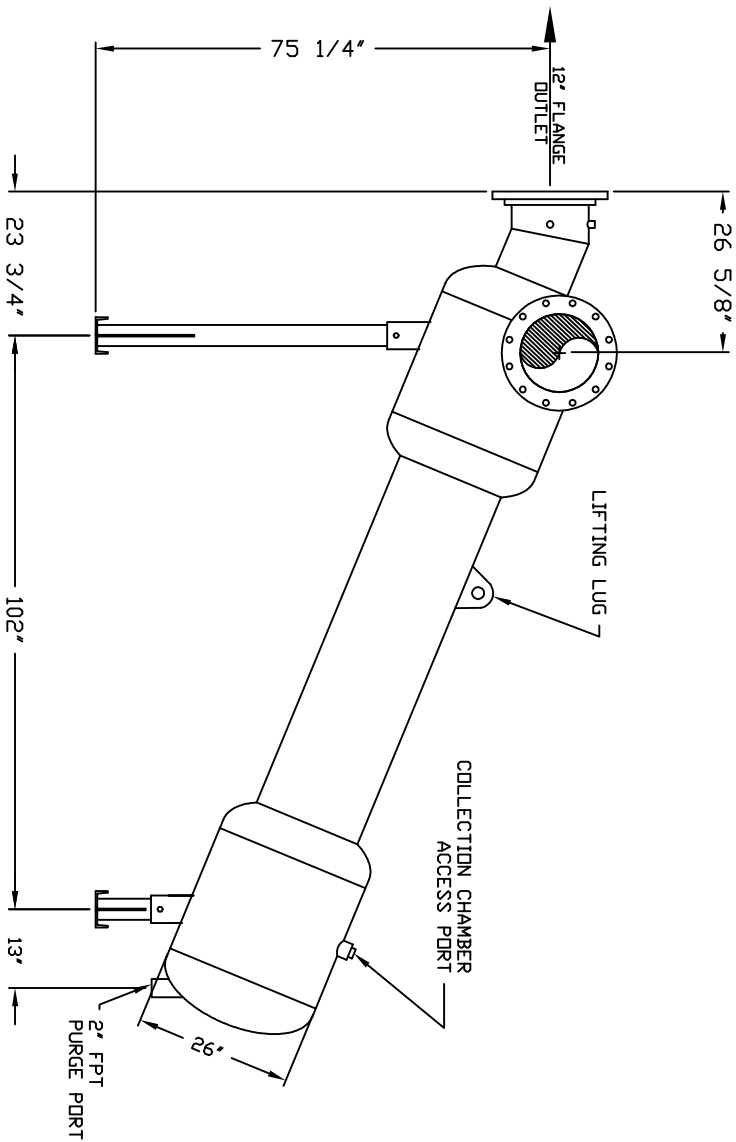

FLOW RATE: 2025-3400 GPM
 MAX PRESSURE: 150 PSI MAX
 MIN BACK PRESSURE: 15 PSI

THIS DRAWING, INCLUDING THE INFORMATION IT CONTAINS, IS CONFIDENTIAL, PROPRIETARY AND IS THE PROPERTY OF YARNEY WATER MANAGEMENT, INC. IT IS SUBMITTED ONLY IN CONNECTION WITH THE TRANSACTION TO WHICH IT PERTAINS AND MUST NOT BE USED IN ANY OTHER MANNER DETRIMENTAL TO THE INTERESTS OF YARNEY WATER MANAGEMENT. THE DRAWING IS NOT TO BE COPIED AND MUST BE RETURNED UPON REQUEST. COPYRIGHT YARNEY WATER MANAGEMENT SYSTEMS, 1993

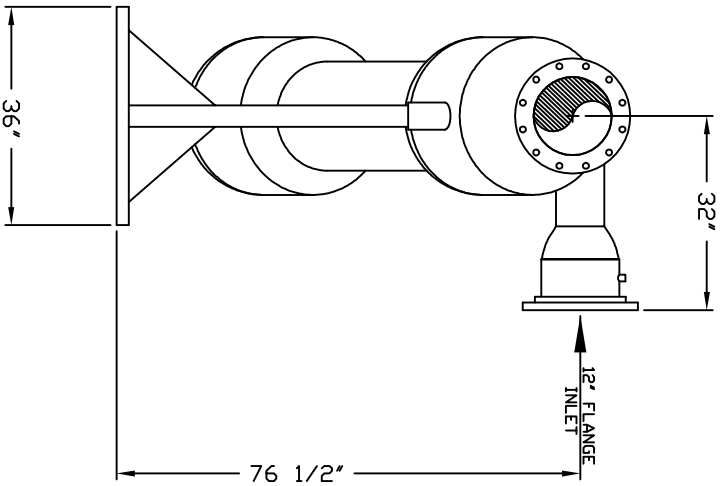

WATER MANAGEMENT SYSTEMS
 RIVERSIDE, CALIFORNIA

SEPARATOR R-120LA

ANGLED

SYMBOL	REVISIONS	BY	DATE	APP	APPROVALS	DATE
A	MANUFACTURING CHANGES	DTC	1-06	APP	APPROVED BY: JMW	6/5/01
					CHECKED BY:	
					ARCHITECTURAL SCALE:	
					SIZE	DRAWING NO.
					-	R-120LA
					SCALE	REV.
					DWG DIR: SEPARATORS\PCSS\AG	A
					SHEET	1 OF 1