

## Ramp Plank Assembly – Ramp Part 2C

1. Using a jig, attach the brace to the underside of the 2x6 planks. Attach with 2 1/4" plated screws. Be sure to use the jig to keep the ramp assembly square.
2. Shave the bottom of the receiving end of the plank with an electric hand planer for a better fit.
3. Wrap the protective plastic sheet over the end of the 2x6 planks. This protects the aluminum from the corrosive treated lumber.
4. Slide the 2x6 plank assembly onto the 11" ramp bracket. Make sure there is approximately 1/4" hanging off both sides of the bracket.
5. Using the holes in the bracket as a guide, drill 5/16" holes through each of the 2x6 wood planks.
6. Attach the 2x6 wood plank to the bracket using the carriage bolts & flange nuts included in the kit.

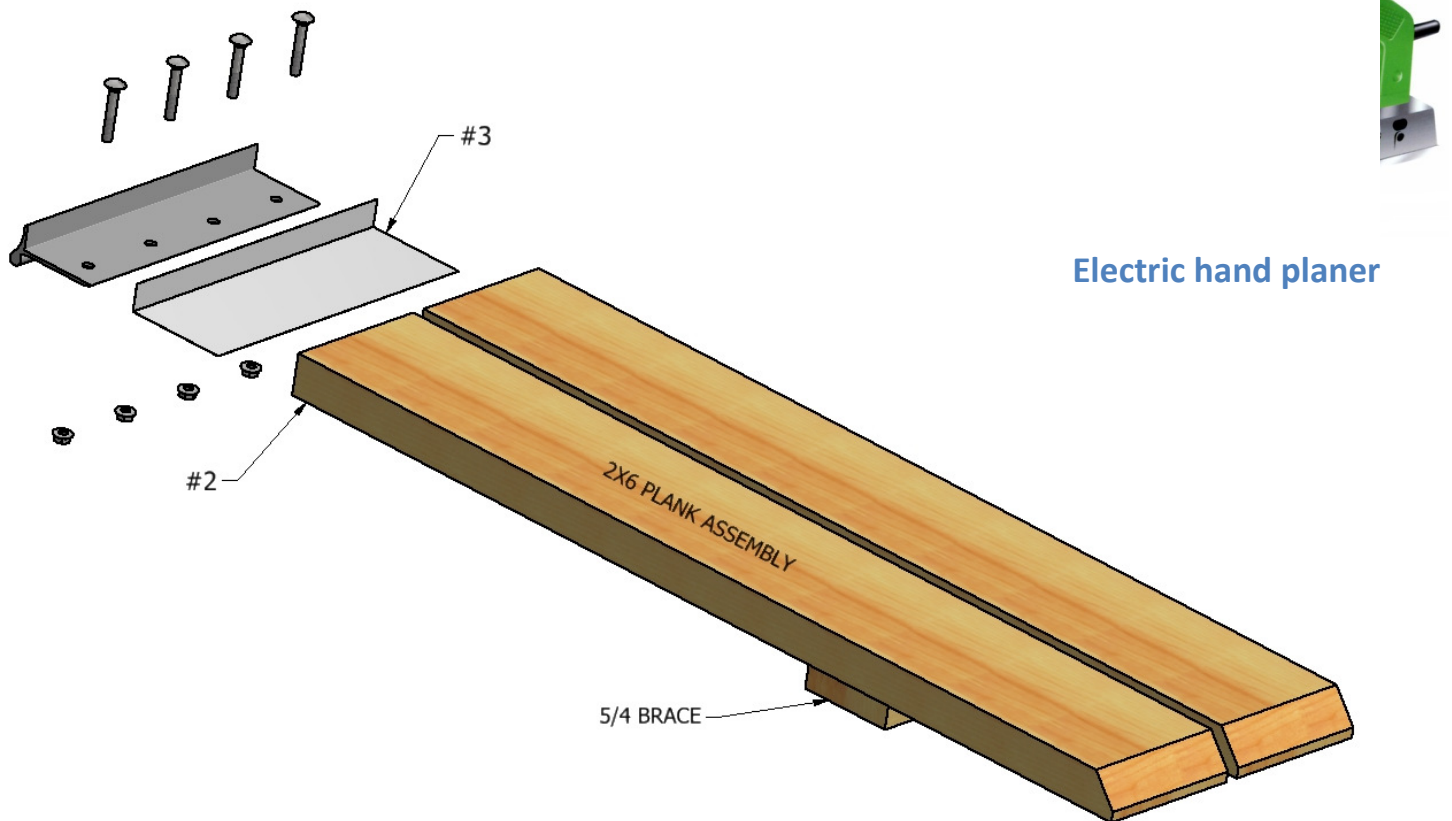

Electric hand planer

