

GROVE B-5 BALL VALVES 6" — 48"

Class 150-1500

End Connections: Flanged, Weld, Weld x Flange

FEATURES:

- Through conduit, full opening, or venturi
- Bubble tight seal
- Nickel plated mirror finish smooth ball
- Double block and bleed
- Trunnion mounted ball for ease of operation at high pressure
- Large diameter, short coupled trunnions to minimize unit bearing loads and operating torque
- Metal-backed DU®* sleeve bearing and trust washers reduce torque and extend service life.
- Free floating stem and rigid bearing construction eliminates cocking of stem and trunnion due to side pressure loads at the ball.
- Double barrier stem seals. Upper seal can be replaced with the valve in the line and under pressure
- Valve is designed to permit field conversion to gear or power operators while valve is in the line and under pressure
- Bolted construction permits disassembly on job-site for repairs
- Locking devices available
- Independent sealing on upstream and downstream seats
- O-ring Seals are protected from line flow, their squeeze action keeps ball clean and easy turning
- Precision machined metal seat rings for primary sealing, backed up by "O" rings which afford the secondary bubble-tight seal.
- Built in sealant inspection system for emergency shut-off. Sealant is not required for normal operation. (See page 20.)
- Integral stop and stop collar for permanent reference to open and closed positions.

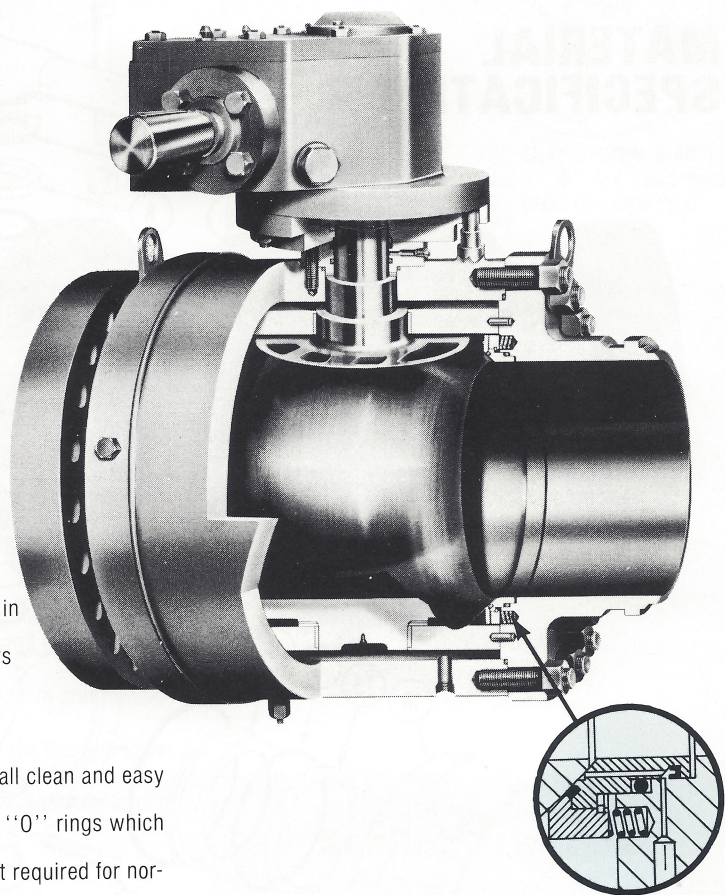

STEM CONSTRUCTION

The stem is separate from the ball and is positioned to the upper ball trunnion by hardened steel pins. Bearing blocks are located on the upper and lower ball trunnions which absorb all the pressure load on the ball. The stem is a free member and carries no side thrust. Absence of this side load and friction drag on the stem assures lower operating torque and long trouble-free service life.

STEM SEALS

The stem is sealed by means of two "O" rings. If leakage should ever occur through both stem seals, the secondary "O" ring can be replaced with the valve in the line, under pressure. When the valve is in the closed position and the body pressure bled off to atmosphere, it is possible to remove the gland for replacement of both primary and secondary stem "O" rings. Stem can also be removed and replaced if necessary.

SEAT SEALS

The patented seat design assures dead-tight independent upstream and downstream sealing. When the ball is in the closed position, sealing is performed by both a primary metal-to-metal seal and a secondary, protected Grovex®** "O" ring seal. The inner lip of the metal seat and the Grovex seal ride on the mirror-finished surface of the electroless nickel plated ball. This is a trunnion-mounted, fixed-ball design, employing floating seals which achieve independent sealing. The ball is positioned in the valve and restricted to rotation about its vertical axis by top and bottom trunnions. The initial seal, at extremely low pressure differential, or vacuum conditions, is obtained upstream and downstream with spring-loaded floating seats, which are free to move slightly along the longitudinal axis of the valve. Line pressure behind the upstream seat ring supplements the seat spring load to force the upstream seat tightly against the ball. The downstream seat also utilizes line pressure (or valve body pressure) through unbalanced-pressure principle as a springload supplement to force downstream seat tightly against the ball (refer to page 20 illustration). This results in upstream and downstream bubble-tight seals which function independently under all pressure conditions. This type of sealing pressure assures double block and bleed service.

TORQUES

Grove's low operating torques are due to our "separate" free floating stem design, which does not absorb any side loads brought on by differential pressures. Our lower operating torques eliminates the need for spur or compound gearing. This results in a lesser number of hand wheel turns to operate our ball valves and/or smaller power actuators.

SEALING PRINCIPLE

Differential pressure forces the floating independent seats against the ball.

Downstream seat utilizes valve body pressure to force seat tightly against the ball.

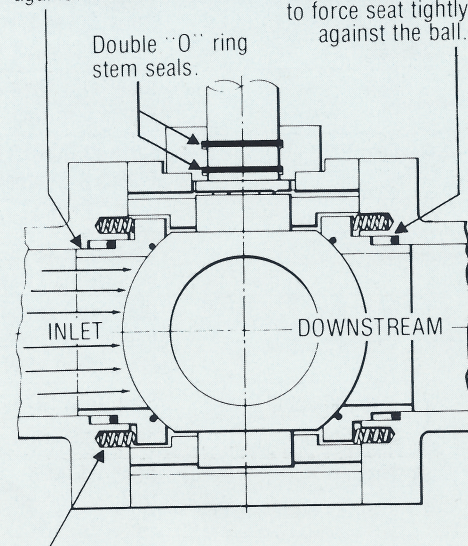

At low or no differential pressure, spring-loaded seats assure bubble-tight seal.

(SEE PAGE 20)

* Trademark of The Garlock Co.

** Trademark of Grove Valve and Regulator Co.

B-5 MATERIAL SPECIFICATIONS

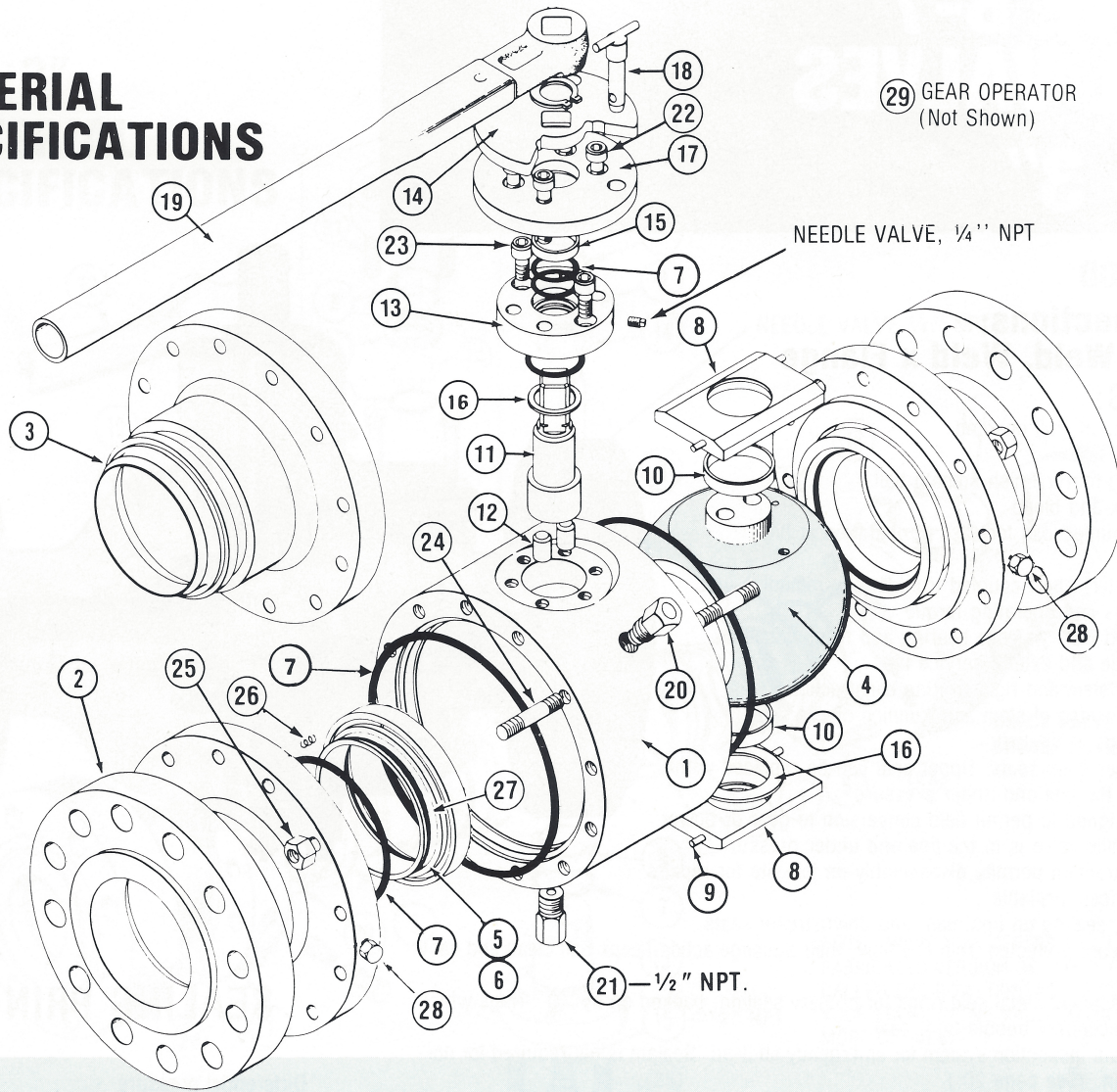

29 GEAR OPERATOR
(Not Shown)

NEEDLE VALVE, 1/4" NPT

21—1/2" NPT.

PART NAME	MATERIAL
1. Body	Steel-ASTM A-36, A-572, A-537, A-106, A-216 Gt. WCC
2. Closure—Flanged End	Steel-ASTM A-36, A-572, A-537, A-106, A-216 Gr. WCC or WCB, A350-LF2
3. Closure—Weld End	Steel-ASTM A-36, A-572, A-537, A-216 Gr. WCB or WXX, A-350-LF2
4. Ball	Nodular Iron-ASTM A-395 Grade 60-40-18; or Steel ASTM A-148 Gr. 90-60 Electroless Nickel Plated
5. Inner Seat Ring	Steel-ASTM A-36, A-572, A-537, Electroless nickel plated
6. Outer Seat Ring	Steel-ASTM A-36, A-572, A-537, Electroless nickel plated
7. "O" Rings	* Grovex Composition
8. Bearing Retainers	Steel-ASTM A-36, A-572, A-537
9. Dowel Pins (Retainer)	Steel-AISI C1212, or 4140
10. Bearings	DU® Self lubricated TFE fluorocarbon resin bonded to low carbon steel backing
11. Stem	Steel-AISI C-1213, C-1018 Electroless nickel plated

*GROVEX covers a variety of elastomeric materials

NOTE: Always consult Grove direct for an exact description of materials currently being used or available.

PART NAME	MATERIAL
12. Drive Pins	Steel-AISI 4140, Heat Treated
13. Gland Plate	Steel-ASTM A-36, A-572, A-537
14. Stop Collar	Steel-ASTM A-36, A-572, A-537
15. Gland Bushing	Steel-AISI C-1015, ASTM A-106 Pipe
16. Thrust Washers	Filled Phenolic
17. Stop Plate or Adaptor Plate	Steel-ASTM A-36
18. Lock Pin	Steel-AISI C-1018
19. Wrench	Nodular Iron-ASTM A-395 Steel-ASTM A-106 Pipe
20. Relief Valve Assembly	Steel-AISI 1018
21. Drain Valve	Steel-AISI 1018 & AISI 4140
22. Capscrew (Stop Plate)	Alloy Steel ASTM A-574
23. Capscrew (Gland Plate)	Alloy Steel ASTM A-574
24. Stud	Steel ASTM A-193 B7M
25. Nut	Steel ASTM A-194 2HM
26. Seat Springs	Steel-AISI-302 Chrome Nickel
27. U Cup Ring	Grovex Composition
28. Check Valve & Grease Fitting	Steel-AISI C-1213
29. Gear Operator	See Page 18 for Material Spec. on Grove SY Operators