

---

Owner's Manual  
**Hydraulic Hand Pump**

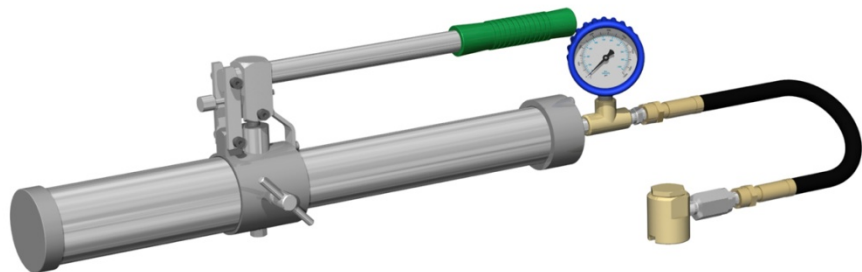

**By Sealweld Corporation**

This document is for the purpose of the Sealweld Hydraulic Hand Pump operation only and is not considered a guide for valve maintenance. We are pleased to offer a valve maintenance program “ValvePro®” and trust you will find the lessons detailed in this program useful when maintaining the valves at your facility. Should you have any questions regarding any of the ValvePro® procedures or if you know of any successful procedures you would like to share, please contact us at:

### **Sealweld Corporation**

#106, 4116-64 Ave. S.E., Calgary, Alberta, Canada T2C 2B3  
Telephone: 1-403-236-0043 Fax: 1-403-236-5487  
TOLL FREE 1-800-661-8465  
Email: [info@sealweld.com](mailto:info@sealweld.com)  
Web Site: [www.sealweld.com](http://www.sealweld.com)

### **Sealweld (USA), Inc.**

6450 Skyview Drive, Houston, Texas, USA 77041  
Telephone: 1-713-466-7373 Fax: 1-713-466-7778  
TOLL FREE 1-800-624-4301  
Email: [info@sealweld.com](mailto:info@sealweld.com)  
Web Site: [www.sealweld.com](http://www.sealweld.com)

### **ValvePro® Technical Support**

Telephone: 1-403-236-0043 Fax: 1-403-236-5487  
Email: [support@valvepro.com](mailto:support@valvepro.com)  
Web Site: [www.valvepro.com](http://www.valvepro.com)

### **The information in this manual is intended as a guide only.**

Read our Disclaimer on page thirty-seven (37).  
Always consult the valve manufacturers recommended maintenance procedures.

Sealweld®, ValvePro® and FLOW WOLF® are registered trademarks and/or patents of Sealweld Corporation.

NGRAIN is a registered trademark of NGRAIN (Canada) Corporation

**MADE IN CANADA**  
*Revised 5/26/2010*

# Contents

<b>Introduction</b>	<b>1</b>
Hydraulic Hand Pump .....	1
<b>Safety Considerations</b>	<b>2</b>
Hydraulic Hand Pump Specific Safety Considerations .....	2
Personal Safety .....	2
High Pressure Hose .....	3
<b>NGRAIN</b>	<b>4</b>
Using NGRAIN Technology .....	4
<b>Operating Instructions</b>	<b>5</b>
How to Operate a Hydraulic Hand Pump .....	5
How to Load a Hydraulic Hand Pump .....	6
Prepare for Loading .....	6
To Load a Cartridge .....	7
To Load a Stick-Type Grease .....	9
To Load a Grease Bag or Gun-Pack .....	10
<b>Care and Maintenance</b>	<b>12</b>
Simple Rules .....	12
Pump Maintenance .....	14
Bleeding and Filling the Hydraulic Fluid Bag .....	14
Fluid Bag Removal .....	16
Fluid Bag Installation .....	17
Relief Valve Replacement .....	18
Check Valve Repair and Replacement .....	18
Piston Assembly Removal and Repair .....	19
Pump Piston Cartridge Repair and Replacement .....	21
By-Pass Valve Repair and Replacement .....	22
Sealant Barrel O-Ring and Gasket Replacement .....	23
Hose Assembly Replacement .....	24
Pressure Gauge Replacement .....	24
Linkage Assembly Repair and Replacement .....	25
Handle Latch Repair and Replacement .....	26
Storing the Hydraulic Hand Pump .....	28
<b>Parts Guide</b>	<b>29</b>
Parts Illustration .....	29
Parts List .....	30
How to Order Hydraulic Hand Pump Parts .....	32
Repair Kits .....	32
<b>Troubleshooting</b>	<b>33</b>
Troubleshooting the Hydraulic Hand Pump .....	33
Testing the Pump .....	33
<b>Warranty</b>	<b>37</b>
Hydraulic Hand Pump Warranty .....	37
Disclaimer .....	37
Contact Information .....	38

# Introduction

---

## Hydraulic Hand Pump

The Hydraulic Hand Pump is a hand-held hydraulic sealant injection pump that is rated to 10,000 PSI and operates in any position. It is very portable making it easy to keep one in your pickup for quick top-ups and emergency sealing jobs between regular maintenance intervals. It is perfect for pumping small quantities of cleaners, sealants and lubricants into valves.

Features include:

- Locking handle to prevent damage to the pump
- Easy to handle, very portable
- Self-priming hydraulic action makes manual injection simple
- Generates up to 10,000 PSI when required
- Easily reloads with cartridge, bag or stick type products
- Discharges one (1) ounce of product easily with every fifty (50) strokes
- Easy to read high pressure gauge
- Buttonhead coupler quickly attaches to and releases from fittings

The Hydraulic Hand Pump ships with an eighteen (18) inch long hose, Giant Buttonhead Coupler #17G and 15,000 PSI Gauge with Guard #17B. It is ready to load and use right out of the box. The working principle is simple; as the Handle #10 is stroked hydraulic fluid pushes the Piston Assembly #2 in the Sealant Barrel #3 forcing product out through the High-pressure Hose Assembly #17. Continue stroking the Handle #10 and pressure will continue to increase.

Once the valve line pressure is exceeded product will begin to flow into the valve. When a sufficient quantity of product has been injected the Hydraulic Hand Pump may be removed by opening the By-Pass Valve #7 then slipping off the Giant Buttonhead Coupler #17G from the buttonhead fitting.

### **READ THIS MANUAL THOROUGHLY BEFORE OPERATING**

*Refer to the “Parts Illustration” on page twenty-nine (29) for all references to part numbers in this manual.*

# Safety Considerations

---

## Hydraulic Hand Pump Specific Safety Considerations

Sealweld Products are designed for industrial use only and the Hydraulic Hand Pump should only be used by a **Certified Valve Technician** who is familiar with the working principals, mechanical limitations & working pressures of the valve being serviced. When working with pressurized valves & lines use extreme caution and do not take risks or short cuts. Always have a proper size stabbing valve ready in case of a valve fittings failure.

When working with valves in a toxic or low O<sub>2</sub> deficient environment, **ALWAYS** wear a self contained breathing apparatus and have backup safety watch standing by. Use extreme caution before opening a body vent fitting.

**ALWAYS** consult the Valve Manufactures manual prior to commencing work on any valve. Do not exceed working pressure of valve when filling the body cavity. **NOTE:** Keep injection pressure below 27580 kpa (4000 psi) on cast iron or semi steel valves.

**CAUTION:** Never hit the Giant Buttonhead Coupler #17G with hammer or other object to attach or remove the coupler from a fitting. Doing so may result in damage to the fitting which could cause serious personal injury or death.

**WARNING:** In the event where the internal checks in the valve under service fail, it will be very difficult or impossible to remove the Giant Buttonhead Coupler #17G. Ensure that you have all the proper tools, procedures & product readily available should this problem arise. **DANGER:** Product may push back into Sealant Barrel #3 contaminating the Hydraulic Hand Pump. **NEVER** leave a contaminant in the Sealant Barrel #3 of the Hydraulic Hand Pump.

**NEVER** operate a pump without a properly functioning pressure gauge or if the gauge shows signs of over pressurization and is in poor operating condition. The Internal Safety Relief Valve #8 is set to 68950 kPa (10,000 psi). The gauge should never exceed 75843 kPa (11,000 PSI).

**ALWAYS** leave By-Pass Valve #7 open and the Sealant Barrel #3 fully loaded when not in use. See “*Storing the Hydraulic Hand Pump*” on page twenty-eight (28).

**WARNING:** Do not use a pump if it has been damaged. Use a mild solvent & clean cloth to keep the pump in clean operating condition.

**NEVER** carry hand pump by its Handle #10 unless it has been latched and secured or carry it by the Hydraulic Pump Hose Assembly #17.

**ALWAYS** replace damaged or missing parts.

**WARNING:** Hydraulic pressure created inside the valve with a high pressure grease pump can stretch bolts on bolted plug valve and cause leakage. Should this occur, release pressure in the pump and Hydraulic Pump Hose Assembly #17. The flange should sit back down and leakage should stop.

**WARNING:** Light valve lubricants, cleaners or liquid products can become a **dangerous** projectile in the event of a hose or fitting failure while under high pressure.

**DO NOT** remove nameplates or labels.

---

## Personal Safety

**Stay alert.** Do not use while tired or under the influence of alcohol, drugs or medications.

**Dress properly.** Always wear approved Personal Protective Equipment (PPE). Do not wear loose clothing or jewelry. Contain long hair. Keep your hair, clothing and gloves away from moving parts.

**At all times**, keep proper footing and balance, maintain a firm grip when using a pump, and do not over-reach.

**Maintain a safe working environment.** Keep a clean work site. Ensure that you have proper lighting and that you have completed a Job Hazard Assessment (JHA). Ensure that you have the proper work permits and that your fellow workers are aware of the procedures and scope of work that you are about to perform.

**ALWAYS** turn off your vehicle and work well down wind of all sources of spark or ignition.

---

## High Pressure Hose

Use only Sealweld Corporation replacement parts and hoses.

**NEVER** carry the Hydraulic Hand Pump by the high pressure hose.

Hose life is reduced by factors that include:

**Environment** - Temperature extremes, UV light, chemicals, ozone, etc. will degrade the rubber used in hydraulic hoses.

**Abrasion and Cuts** - Wear against other hoses or objects will wear off the outer cover and lead to corrosion of the reinforcing mesh.

**Extreme Pressure Fluctuations** - Pressure surges above the hose's working pressure will damage hose components.

**Improper Length/Routing** - Excessive bending of the high pressure hose causes high stresses in the hoses components that may also reduce pressure capacity (avoid multi-plane bending, small bend radii, tension in hose, etc.). Hose life can be reduced by 90% when subject to these type of stresses.

# NGRAIN

---

## Using NGRAIN Technology

The Hydraulic Hand Pump manual has been updated to include cutting-edge imaging technology by NGRAIN. This new format allows the reader to practice disassembly and reassembly of practically any type of mechanical device in a 3D view. Images in this PDF files displaying an NGRAIN logo are interactive.

The NGRAIN Viewer is only available for Microsoft Windows® Operating System. If you do not have a Windows® Operating System you will not be able to view the models. To install the most current release directly from NGRAIN.ca [CLICK HERE](#), select their Downloads link. Follow all installation instructions provided.

Once you see the NGRAIN logo, you then activate NGRAIN by clicking on the logo. It will take a few seconds for the model to load, please be patient.

Once loaded you will see control icons across the top of the picture that allow you to manipulate the model. As you move your mouse over each icon it will display a text box describing its purpose. These are very basic tools that are easy to use.

You can reference the Help file or just play around until you get the hang of it. This is designed to be simple and easy to operate.



*The image directly above is embedded with an NGRAIN model.*

# Operating Instructions

---

## How to Operate a Hydraulic Hand Pump

Before operating the Hydraulic Hand Pump read and remember the “*Simple Rules*” listed on page twelve (12) in the “*Care and Maintenance*” section of this manual.

- NOTE: If at any time you feel the Hydraulic Hand Pump is not operating as expected see “*Troubleshooting*” on page thirty-three (33).

The Hydraulic Hand Pump operator should be familiar with the working principals and the mechanical limitations of the pipeline valve being serviced.

**IMPORTANT:** Be sure you have read and understand the “*Safety Considerations*” section of this manual before operating this pump.

To operate the Hydraulic Hand Pump:

1. The Hydraulic Hand Pump must first be loaded. See “*How to Load a Hydraulic Hand Pump*” on page six (6).
2. Inspect the Giant Buttonhead Coupler #17G for damage and contaminants. Clean using a mild solvent and a clean cloth if required.
3. Attach the Giant Buttonhead Coupler #17G to a buttonhead fitting on the valve being serviced.
  - **IMPORTANT: ALWAYS** follow the valve manufacturer's recommendations and instructions when servicing each type of valve.
4. Close By-Pass Valve #7 hand-tight only.
5. Pull back the Stem and Knob #16A to release the Handle #10.
6. Lift the Handle #10 up until it reaches it full height.
7. Pull the Handle #10 all the way down. Steps six (6) and seven (7) together is one (1) stroke.
8. By stroking the Handle #10, product is injected into the valve and pressure will begin to build. It could require 10 - 15 full strokes before pressure begins to builds up in the pump. As you stroke, monitor the pressure on the 15,000 PSI Gauge #17B.
  - **NOTE:** An important part of operating the Hydraulic Hand Pump is to detect when the pump is empty. As you service a valve the Handle #10 will become increasingly difficult to pull down with each stroke and the pressure on the 15,000 PSI Gauge #17B will drop to zero (0) PSI. When this happens it is time to reload the pump. See “*How to Load a Hydraulic Hand Pump*” on page six (6).
  - **NOTICE:** Once you become familiar with reading the gauge properly you will be able to judge when sealant begins to enter the valve.
  - Consult “*The Digital HANDBOOK of Valve Lubrication & Maintenance*” for more information on Pressure Gauge Reading Techniques.



9. The Hydraulic Hand Pump requires fifty (50) strokes to transfer approximately one (1) fluid ounce of product. Once you have injected the required amount of product, open the By-Pass Valve #7 and slide the Giant Buttonhead Coupler #17G off the fitting on the valve.
  - The 15,000 PSI Gauge #17B must have a zero (0) reading before the Giant Buttonhead Coupler #17G can be easily removed. If a zero (0) reading cannot be obtained it could indicate that:
    - i. The check valves in the buttonhead fitting and in the valve have failed creating a dangerous situation.
    - ii. Product has entered the bourdon tube of the 15,000 PSI Gauge #17B. See “*Pressure Gauge Replacement*” on page twenty-four (24).

Repeat this procedure as required for each valve to be serviced.

- *ALWAYS connect the Latch Arm #16E to the Stem and Knob #16A whenever you need to carry the Hydraulic Hand Pump.*

---

## How to Load a Hydraulic Hand Pump

*BEFORE attempting to load the Hydraulic Hand Pump, ensure that all pressure has been released.*

The Hydraulic Hand Pump can be loaded from either a cartridge or bag. It can also be loaded with a stick type product. It is designed to hold approximately twelve (12) ounces of product in the Sealant Barrel #3. Sealweld has developed a shorter HG series cartridge specifically for loading the Hydraulic Hand Pump.

**WARNING:** Light valve lubricants, cleaners or liquid products can become a **dangerous** projectile in the event of a hose or fitting failure while under high pressure. ALWAYS wear certified personal protective equipment while operating a high pressure pump.

*All Loading instructions are based on the Hydraulic Hand Pump Sealant Barrel #3 being empty.*

### Prepare for Loading

1. Open By-Pass Valve #7 to relieve any internal pressure by turning it counter-clockwise one (1) full turn.
2. Look at the 15,000 PSI Gauge #17B to make sure the pressure is (0 PSI) zero.
3. Connect the Latch Arm #16E to the Stem and Knob #16A.
4. Detach the Giant Buttonhead Coupler #17G from the fitting on the valve.
  - **NOTICE:** *Always relieve any internal pressure by opening the By-Pass Valve #7 one full turn before detaching the Giant Buttonhead Coupler #17G from the fitting on a valve.*
5. Remove the head assembly (Sealant Barrel Cap #1 and Hydraulic Pump Hose Assembly #17) from Sealant Barrel #3.
  - If the head assembly will not unscrew easily, double check to make sure By-Pass Valve #7 is OPEN. Use Handle #10 to increase leverage, the stub on the Sealant Barrel Cap #1 fits into the hole at the end of the Handle #10.
  - **DANGER:** *Use extreme care removing the head assembly when the Hydraulic Hand Pump has been used to service toxic pipelines. There is a remote possibility that pipeline product can enter and contaminate the Hydraulic Hand Pump.*
6. Look inside the Sealant Barrel #3, The Piston Assembly #2 should be near the end of the Sealant Barrel #3.

- If the Piston Assembly #2 is not near the end of the Sealant Barrel #3 and product remains in the barrel, reattach the head assembly, stroke the Handle #10 until the remaining product has been pumped out.
- If the Piston Assembly #2 is not near the end of the Sealant Barrel #3 and no product remains in the Sealant Barrel #3, stroke the Handle #10 until the Piston Assembly #2 is level with the end of the Sealant Barrel #3.

**NOTICE:** *If you can see hydraulic fluid in the Sealant Barrel #3 the Hydraulic Hand Pump must be serviced. See “Piston Assembly Removal and Repair” on page nineteen (19).*

7. If you are changing products, scoop out any remaining product and clean off the top of the Piston Assembly #2 and Sealant Barrel Cap #1 using a mild solvent and a clean cloth.
8. Place the head assembly in a clean, dry place to avoid any contamination.

The Hydraulic Hand Pump is now ready to load.

*Use the following instructions for the type of product you need to load.*

## To Load a Cartridge

The use of cartridge type lubricant / sealants has been found to greatly reduce the risk of product contamination and trapped air in any pump.

The Sealweld EZ-LOADER® was designed to make loading of cartridges quick and easy. Sealweld has developed a shorter HG series cartridge specifically for loading the Hydraulic Hand Pump using the EZ-LOADER.

The longer SG series cartridge can still be used to load the Hydraulic Hand Pump with the use of the EZ-LOADER, but because of the limited size of the Sealant Barrel #3 some product will remain in the cartridge.

## With an EZ-LOADER

*The Hydraulic Hand Pump must be prepared for loading as previously instructed with the Piston Assembly #2 at the top of the Sealant Barrel #3 and the By-Pass Valve #7 opened.*

Follow these EZ-LOADER instructions:

1. Remove the Adapter Ring from the EZ-LOADER. Check that the Barrel is empty. If not, remove the empty cartridge from inside the EZ-LOADER by pulling the T-handle back, then pushing it forward.
2. Push the T-handle fully into the EZ-LOADER. Remove the cap from the sealant cartridge and then place the opened end of the cartridge in to the EZ-LOADER. As the cartridge enters the T-handle will push out. You can also pull the cartridge into EZ-LOADER with the T-handle.
3. When the cartridge is fully inserted, pull the pull-tab off the bottom of the cartridge.
4. Re-attach and tighten the Adapter Ring onto the EZ-LOADER.
5. Attach the EZ-LOADER to the Sealant Barrel #3 with the Adapter Ring but leave the threads loose. Gently push the EZ-LOADER T-handle forward until contact is made between sealant and Piston Assembly #2; this forces any trapped air to escape through loose threads. Firmly tighten the EZ-LOADER assembly to the Sealant Barrel #3.
6. Set the EZ-LOADER T-handle on the floor with the back end of the Hydraulic Hand Pump pointing up. Make sure the rod on the EZ-LOADER is properly aligned so it can slide in and does not bend.
7. Push down on the body of the Hydraulic Hand Pump. The T-handle on the EZ-LOADER should slide in as Hydraulic Hand Pump slides down. This action will transfer the sealant from the EZ-LOADER into the Sealant Barrel #3.
8. When the T-handle on the EZ-LOADER is fully inserted the Sealant Barrel #3 is full of sealant.

- **NOTICE:** The T-handle may not be able to go fully in when a larger SG series cartridge is used. The T-handle will protrude out approximately 1-1/2" and excess force will bend the T-handle shaft damaging the EZ-LOADER.
9. Unscrew the EZ-LOADER and Adapter Ring from the Sealant Barrel #3.
    - Remember to remove the empty cartridge from the EZ-LOADER as soon as you have finished reloading.
  10. To make sure that there is no air trapped at the end of the Sealant Barrel #3, push the sealant forward by closing the By-Pass Valve #7 and stroke the Handle #10 until the sealant is level with the end of the Sealant Barrel #3.
    - **NOTICE:** When using a larger cartridge you may need to remove excess sealant with a putty knife so the sealant is level with the end of the Sealant Barrel #3.
  11. Screw the head assembly onto the end of the Sealant Barrel #3 and tighten firmly.
    - If the product is being changed, place the Giant Buttonhead Coupler #17G into an empty bucket and stroke the Handle #10 until the new product is seen extruding from the Giant Buttonhead Couple #17G. This will take approximately one-hundred (100) strokes.
  12. Open the By-Pass Valve #7 one full turn.
  13. Wipe any excess sealant from the outside of the Hydraulic Hand Pump with a mild solvent and a clean cloth.
  14. The Hydraulic Hand Pump is now ready for use.

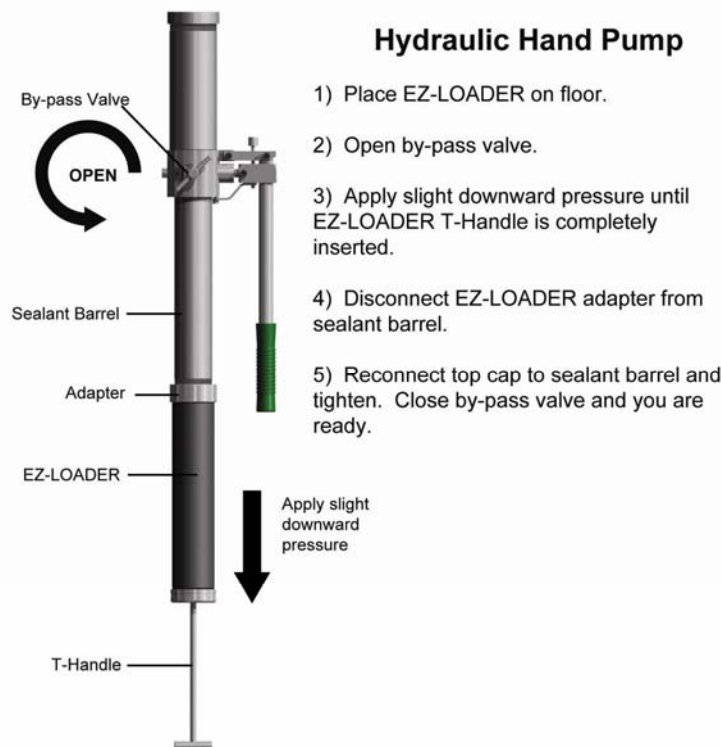

The image above contains an NGRain model with an animation showing the EZ-LOADER procedure.

## Without an EZ-LOADER

*The Hydraulic Hand Pump must be prepared for loading as previously instructed with the Piston Assembly #2 at the top of the Sealant Barrel #3 and the By-Pass Valve #7 opened.*

Follow these instructions:

1. Remove the cap from the cartridge.
2. Place the opened end of cartridge over the OUTSIDE of Sealant Barrel #3 (the Sealant Barrel #3 goes inside the cartridge).
3. Place the Hydraulic Hand Pump on the floor in an upright position with the cartridge at the top.
4. Place your palm over the end of the cartridge then slowly push the cartridge down over the Sealant Barrel #3, until the cartridge has bottomed out (feel the cartridge for the top of the Sealant Barrel #3, the larger (16) sixteen will stop approximately 1-1/2" from the end of the Sealant Barrel #3).
5. Remove the pull tab from the end of the cartridge (for the larger SG series cartridge, instead of pulling the tab off the end of the cartridge you should cut off the remaining 1-1/2" of cartridge).
6. Slide the empty cartridge off the Sealant Barrel #3. It should come off quite easily but if not, it may help if you turn or spin it as you slide it.
7. To make sure that there is no air trapped at the end of the Sealant Barrel #3. Push the sealant forward by closing the By-Pass Valve #7 and stroke the Handle #10 until the sealant is level with the end of the Sealant Barrel #3. Remove any excess sealant with a putty knife so the sealant is level with the end of the Sealant Barrel #3.
8. Wipe any excess sealant from the outside and the threads of the Sealant Barrel #3 with a mild solvent and a clean cloth. Take care not to contaminate the sealant.
9. Replace and tighten the head assembly onto Sealant Barrel #3.
  - If the product is being changed, place the Giant Buttonhead Coupler #17G into an empty bucket and stroke the Handle #10 until the new product is seen extruding from the Giant Buttonhead Coupler #17G.
10. Open By-Pass Valve #7 one full turn.
11. Wipe any excess sealant from the outside of the Hydraulic Hand Pump with a mild solvent and a clean cloth.

The Hydraulic Hand Pump is now ready for use.

## To Load a Stick-Type Grease

*The Hydraulic Hand Pump must be prepared for loading as previously instructed with the Piston Assembly #2 at the top of the Sealant Barrel #3 and the By-Pass Valve #7 opened.*

Follow these instructions:

1. Place the Hydraulic Hand Pump on the floor in an upright position with the Sealant Barrel #3 at the top.
2. Remove the Handle #10 from the Fulcrum Assembly #9 and clean off any contaminants such as sand or dirt.
3. Place the Handle #10 so it is centered on the Piston Assembly #2 then push the Piston Assembly #2 to the bottom of the Sealant Barrel #3.
  - **NOTICE:** *be very careful not to scratch or score the inside of the Sealant Barrel #3.*
4. Return the Handle #10 to the Fulcrum Assembly #9.

5. Carefully remove the wrapping from the stick and avoid contaminants such as sand or dirt from contacting the stick. Properly discard the wrapping.
6. Put the stick into the Sealant Barrel #3.
  - If the stick is a tight fit, scribe the stick along its length so air trapped in the Sealant Barrel #3 can escape past the stick.
7. To make sure that no air gets trapped between the head assembly and the Sealant Barrel #3, push the product forward by closing the By-Pass Valve #7 and stroke the Handle #10 until the product is level with the end of the Sealant Barrel #3. Remove any excess product with a putty knife so the product is level with the end of the Sealant Barrel #3.
8. Wipe any excess product from the outside and the threads of the Sealant Barrel #3 with a mild solvent and a clean cloth. Take care not to contaminate the product.
9. Replace and tighten the head assembly onto Sealant Barrel #3.
  - If the product is being changed, place the Giant Buttonhead Coupler #17G into an empty bucket and stroke the Handle #10 until the new product is seen extruding from the Giant Buttonhead Coupler #17G.
10. Open By-Pass Valve #7 one full turn.
11. Wipe any excess sealant from the outside of the Hydraulic Hand Pump with a mild solvent and a clean cloth.

The Hydraulic Hand Pump is now ready for use.

## To Load a Grease Bag or Gun-Pack

*The Hydraulic Hand Pump must be prepared for loading as previously instructed with the Piston Assembly #2 at the top of the Sealant Barrel #3 and the By-Pass Valve #7 opened.*

Follow these instructions:

1. Place the Hydraulic Hand Pump on the floor in an upright position with the Sealant Barrel #3 at the top.
2. Clean off any contaminants such as sand or dirt from the Handle #10.
3. Place the Handle #10 so it is centered on the Piston Assembly #2 then push the Piston Assembly #2 to the bottom of the Sealant Barrel #3.
  - **NOTICE:** *be very careful not to scratch or score the inside of the Sealant Barrel #3.*
4. Return the Handle #10 to the Fulcrum Assembly #9.
5. Clean any contaminants such as sand or dirt from the outside of the bag then cut the end off the bag and discard properly.
6. Slide the bag, opened end first, into the Sealant Barrel #3 then as you pull the bag out, use your fingers to squeeze the contents of the bag into the Sealant Barrel #3.
  - **NOTICE: DO NOT** *leave the bag or any other foreign material in the Sealant Barrel #3. Keep air pockets to a minimum.*
7. To make sure that no air gets trapped between the head assembly and the Sealant Barrel #3, push the product forward by closing the By-Pass Valve #7 and stroke the Handle #10 until the product is level with the end of the Sealant Barrel #3. Remove any excess product with a putty knife so the product is level with the end of the Sealant Barrel #3.
8. Replace and tighten the head assembly onto Sealant Barrel #3.

9. If the product is being changed, place the Giant Buttonhead Coupler #17G into an empty bucket and stroke the Handle #10 until the new product is seen extruding from the Giant Buttonhead Coupler #17G.
10. Open By-Pass Valve #7 one full turn.
11. Wipe any excess sealant from the outside of the Hydraulic Hand Pump with a mild solvent and a clean cloth.

The Hydraulic Hand Pump is now ready for use.

# Care and Maintenance

By following these five (5) easy steps the Hydraulic Hand Pump will operate for many years without requiring any further maintenance.

1. Carefully follow all “*Operating Instructions*” and the “*Simple Rules*” provided.
2. Perform “*Testing the Pump*” annually. See “*Troubleshooting*” on page thirty-three (33).
3. Keep all threaded connections tight.
4. Use a mild solvent or penetrating fluid and a clean rag to keep the Hydraulic Hand Pump clean.
5. Replace or repair any leaking or failed components.

---

## Simple Rules

Following these simple rules will help increase the life of the Hydraulic Hand Pump.

1. **NEVER** carry the Hydraulic Hand Pump by the Handle #10 unless it is secured by the latch or a chain.
  - Carrying the Hydraulic Hand Pump by the Handle #10 without it being secured will result in the Pump Piston #5C and the Linkage Assembly #11 bending. The degree of bend will affect the force required to stroke the Handle #10. If bent badly enough the Hydraulic Hand Pump will not operate as expected, or not at all, and will require replacing the Pump Piston #5C, Hydraulic Piston Cylinder #5 and Linkage Assembly #11.
2. **NEVER** carry the Hydraulic Hand Pump by the Hydraulic Hose Assembly #17.
  - Carrying the Hydraulic Hand Pump by the hose causes unnecessary stress to the hose and fittings.
3. **NEVER** pull sideways or twist the Handle #10 on the Hydraulic Hand Pump.
  - This will damage the Pump Piston #5C and the Linkage Assembly #11 holding the Fulcrum Assembly #9 to the Hydraulic Hand Pump.
4. **ALWAYS** keep the Hydraulic Hand Pump in clean operating condition.
  - Dirt, sand or other debris can easily attach to products left on the outside of the Hydraulic Hand Pump. Handling a dirty Hydraulic Hand Pump will result in the contamination of product while reloading. Injecting contaminated product into valves can cause serious damage to the internal valve components.
  - If debris is allowed to build-up on the Hydraulic Hand Pump, the smooth operation will deteriorate and over time will cause damage.
5. **Protect** the 15,000 PSI Gauge #17B.
  - ***NEVER** use a high pressure lubricant injection pump without a properly working pressure gauge. This pump and all injection equipment can produce extreme pressures very quickly. It is imperative you know what injection pressure your equipment is producing at ALL times.*

- The 15,000 PSI Gauge #17B can easily be damaged if allowed to be struck by objects. Use care when operating and moving the Hydraulic Hand Pump. Never remove the rubber protective guard from the gauge.
  - Store the Hydraulic Hand Pump in a safe place where it will be protected.
6. **ALWAYS** leave the By-Pass Valve #7 OPEN when not in use.
    - When By-Pass Valve #7 is open, accidentally stroking the Handle #10 will not discharge any product where you do not want it.
    - A dramatic change in temperature from cold to hot will cause the hydraulic fluid to expand. With the By-Pass Valve #7 closed this will cause excessive pressure on the hydraulic Fluid Bag #12 and may cause it to leak. With the By-Pass Valve #7 opened this pressure will transfer into the Sealant Barrel #3. A small amount of product may escape through the Giant Buttonhead Coupler #17G however the Hydraulic Hand Pump will not be damaged.
  7. **NEVER** open the By-Pass Valve #7 more than (1) one full turn.
    - Opening the By-Pass Valve #7 more than (1) one full turn could damage the By-Pass Valve O-Ring #7C on the threads holding the By-Pass Valve #7 in place. Hydraulic fluid will leak past the By-Pass Valve O-Ring #7C and air will enter the hydraulic system.
    - Forcing the By-Pass Valve #7 open even more will bend and damage the By-Pass Valve Stop #7A. Once the By-Pass Valve #7 has been opened too far, closing it could severely damage the By-Pass Valve O-Ring #7C. *See “By-Pass Valve Repair and Replacement” on page twenty-two (22).*
  8. **NEVER** use a wrench or force the By-Pass Valve #7 closed.
    - Excess force will damage the By-Pass Valve #7 sealing seat. Once damaged hydraulic fluid will be able to pass through and the pump may not be able to achieve a high pressure seal.
  9. **ALWAYS** check that the Giant Buttonhead Coupler #17G is clean before attaching to a fitting.
    - Dirt, sand or other debris can easily contaminate sealants and lubricants causing serious damage to a valve when injected.
  10. **CAUTION: NEVER** bang on the Giant Buttonhead Coupler #17G with a hammer or other object to attach or remove the coupler from a fitting.
    - This can easily result in damage to the fitting or Giant Buttonhead Coupler #17G which could cause serious property and personal injury.
  11. **ALWAYS** relieve pressure BEFORE detaching the Giant Buttonhead Coupler #17G from the valve.
    - Relieving the pressure will allow the Giant Buttonhead Coupler #17G to slide easily off the fitting. If the Giant Buttonhead Coupler #17G is hard to remove once pressure is relieved it could indicate the internal check in the fitting has failed.
  12. **Keep the Hydraulic Hand Pump fully loaded** or push the Piston Assembly #2 to the bottom of the Sealant Barrel #3 before storing the Hydraulic Hand Pump for long periods of time.
    - As hydraulic fluid is pumped from the Fluid Bag #12 into the Sealant Barrel #3 the Fluid Bag #12 collapses. If the Hydraulic Hand Pump is stored for a long period of time the Fluid Bag #12 will begin to retain this new collapsed making it almost impossible to top-up the hydraulic fluid. This can easily become a messy procedure.
  13. **Do not** continue stroking the Handle #10 when the Sealant Barrel #3 is empty.
    - The Piston Assembly #2 can be damaged as well as other internal parts.
  14. **NEVER** leave valve cleaner or solvent in the Hydraulic Hand Pump when not in use. The Leather Cup #2H will damage with lengthy exposure. Clean the pump thoroughly, inside and out, after using a valve cleaner or solvent.



---

## Pump Maintenance

In most cases where the Hydraulic Hand Pump is not working properly it is because of a problem with the hydraulic fluid level. It is recommended that all hydraulic fluid system instructions be performed in a shop environment to reduce the risk of contamination and spills.

Any type of hydraulic fluid may be used, but DO NOT MIX different types of hydraulic fluid together in the system and do not reuse any hydraulic fluid. Always use new hydraulic fluid.

**ALWAYS** wear certified Personal Protective Equipment when working with hydraulic fluids.

*The following instructions are based on the Hydraulic Hand Pump Sealant Barrel #3 being empty. If possible, pump out all remaining product.*

### Bleeding and Filling the Hydraulic Fluid Bag

Air trapped in the hydraulic system is the most common cause of pump problems and failure. What is important is to know how the air is getting in. Two most common reasons are from loading the pump and opening the By-Pass Valve #7 too far.

- When loading the pump, it is almost impossible to avoid trapping some air in the Sealant Barrel #3, especially when using stick or bag products. This air can then be forced past the Piston Assembly #2 and into the hydraulic system when pressure is applied. Sealweld has developed the EZ-LOADER to help avoid trapping air when loading cartridge type products.
- Opening the By-Pass Valve #7 more than one (1) full turn does not increase the speed in which pressure is relieved. What does happen is the By-Pass Valve O-Ring #7C pulls out enough that it can be damaged by the threads in the By-Pass Valve #7 cavity and as hydraulic fluid drips out, air is allowed in. Tightening the By-Pass Valve #7 then traps and forces the air into the hydraulic system. Over a period of time enough air gets into the hydraulic system to affect the functionality of the system.

To remove air or to refill the hydraulic system, follow these instructions:

**NOTE:** If you have previously performed a maintenance procedure that has instructed you to perform the “Bleeding and Filling the Hydraulic Fluid Bag” instructions, the Piston Assembly #2 should be pushed fully in.

1. Close By-Pass Valve #7 and stroke the Handle #10 at least fifty (50) times.
2. Open By-Pass Valve #7; check the 15,000 PSI Gauge #17B to make sure all internal pressure is relieved from the system.
3. Remove the head assembly (Sealant Barrel Cap #1 and Hydraulic Pump Hose Assembly #17) from Sealant Barrel #3 and place it in a clean spot.
  - If the head assembly will not unscrew easily, double check to make sure By-Pass Valve #7 is OPEN. Handle #10 can be used to increase leverage. The stub on the Sealant Barrel Cap #1 fits into the hole at the end of the Handle #10.
4. Turn the Hydraulic Hand Pump so that Sealant Barrel #3 is pointing down, secure in a pipe vise but leave enough room under the Hydraulic Hand Pump so the Handle #10 can still be easily inserted into the Sealant Barrel #3.
5. Let the pump stand for five (5) to ten (10) minutes to allow any trapped air to rise.
  - Gentle tapping on the Sealant Barrel #3 with a hammer will help any trapped air bubbles to rise.
6. Place a suitable container under the Hydraulic Hand Pump to catch any spilled hydraulic fluid.
7. Remove the Handle #10 from the Fulcrum Assembly #9 and clean off any contaminants such as sand or dirt.

8. Place the Handle #10 so it is centered on the Piston Assembly #2 then push the Piston Assembly #2 up to the bottom of the Sealant Barrel #3.
  - **NOTICE:** *be very careful not to scratch or score the inside of the Sealant Barrel #3.*
9. Clean and return the Handle #10 to the Fulcrum Assembly #9.
10. Remove Fluid Bag Barrel Cap #14.
  - Some Hydraulic Hand Pumps are equipped with a set screw in the side of the Fluid Bag Barrel Cap #14 and it must be backed off or removed before the Fluid Bag Barrel Cap #14 can be removed.
11. Remove the bleeder cap screw and washer from Fluid Bag #12. Use a 5/8" wrench to secure the Fluid Bag #12 and an Allen key to remove the bleeder cap screw and washer.
  - **CAUTION:** *It is possible for hydraulic fluid to leak or spray out of the Fluid Bag #12 if the bag is damaged or distorted. USE certified personal protective equipment.*
12. To be sure the Piston Assembly #2 is in its proper position repeat steps seven (7), eight (8) and nine (9).
  - **CAUTION:** *If the Piston Assembly #2 moves, hydraulic fluid may leak or squirt out the top of the Fluid Bag #12.*
13. Using a squeeze bottle, add hydraulic fluid very slowly. Work your fingers around the top of the Fluid Bag #12 to displace any air bubbles inside. Continue until you are satisfied that all of the air bubbles have escaped. Leave the Hydraulic Hand Pump in this position with the bleeder cap screw removed for 5 to 10 minutes.
  - If the Fluid Bag #12 is distorted, leave the Hydraulic Hand Pump in this position with the bleeder cap screw removed over night. If the Fluid Bag #12 does not return to its original shape it will need to be replaced. See "*Fluid Bag Removal*" on page sixteen (16).
  - **NOTICE:** *The Fluid Bag #12 is designed to hold just enough hydraulic fluid to move the Piston Assembly #2 to the end of Sealant Barrel #3. Refilling the Fluid Bag #12 without the Piston Assembly #2 being pushed all the way in will result in further problems when reloading with product.*
14. Pull back the Stem and Knob #16A to release the Handle #10.
15. Slowly stroke the Handle #10 three (3) to five (5) times to help remove any air that is trapped in the Pump Body Assembly #4.
  - The Piston Assembly #2 should not move with the By-Pass Valve #7 open.
16. Repeat steps twelve (12), thirteen (13) and fourteen (14) as many times as required to remove all the air.
17. Connect the Latch Arm #16E to the Stem and Knob #16A.
18. Once Fluid Bag #12 is full, attach the bleeder cap screw and washer to the fluid bag #12. Use a 5/8" wrench to secure the Fluid Bag #12 and an Allen key to tighten the bleeder cap screw.
19. Remove the Hydraulic Hand Pump from the pipe vise and carefully pour out any hydraulic fluid which may have entered into the Fluid Bag Barrel #13, into a suitable container.
20. Put Fluid Bag Barrel Cap #14 back onto the Hydraulic Hand Pump and tighten the set screw if equipped.
  - The Hydraulic Hand Pump can now be reloaded with a bag or stick type product. See "*How to Load a Hydraulic Hand Pump*" on page six (6).
  - For cartridge type product, stroke the Handle #10 until the Piston Assembly #2 is level with the end of Sealant Barrel #3.
21. Attach and tighten the head assembly onto Sealant Barrel #3.

The Hydraulic Hand Pump is now ready for use.

## Fluid Bag Removal

The Fluid Bag #12 is designed to hold enough hydraulic fluid to push the Piston Assembly #2 just past the end of the Sealant Barrel #3. As fluid is pumped out of the Fluid Bag #12 it will collapse. Infrequent use or improper storage of the pump causes the bag to hold the collapsed shape. Keeping the Sealant Barrel #3 full or following the proper storage instructions helps it retain its normal shape. If the Fluid Bag #12 has collapsed and does not return to its normal shape after removal, place it in a warm area and let stand for 24 hours. If it still does not regain its normal shape it will be difficult to refill and should be replaced.

To remove the Fluid Bag #12, follow these instructions:

1. Have a pipe vise ready and a clean area prepared where you can place parts as they are removed.
2. Open By-Pass Valve #7; check the 15,000 PSI Gauge #17B to make sure all internal pressure is relieved from the system.
3. Remove head assembly (Sealant Barrel Cap #1 and Hydraulic Pump Hose Assembly #17) from Sealant Barrel #3.
4. Remove the Handle #10 from the Fulcrum Assembly #9 and clean off any contaminants such as sand or dirt.
5. Place the Handle #10 so it is centered on the Piston Assembly #2 then push the Piston Assembly #2 to the bottom of the Sealant Barrel #3.
  - **NOTICE:** *be very careful not to scratch or score the inside of the Sealant Barrel #3.*
6. Clean and return the Handle #10 to the Fulcrum Assembly #9.
7. Place the Fluid Bag Barrel #13 into a pipe vise and unscrew the Fluid Bag Barrel Cap #14.
  - Some Hydraulic Hand Pumps are equipped with a set screw in the side of the Fluid Bag Barrel Cap #14 and it must be backed off or removed before the Fluid Bag Barrel Cap #14 can be removed.
8. Place a suitable container under the Hydraulic Hand Pump to catch the hydraulic fluid.
9. Remove the Fluid Bag Barrel #13 from the pipe vise and place the Pump Body Assembly #4 into the pipe vise with the Fluid Bag Barrel #13 down.
  - **CAUTION:** *be careful not to damage any of the external parts on the Pump Body Assembly #4 when clamping into the pipe vise.*
10. Remove the bleeder cap screw and washer from Fluid Bag #12. Use a 5/8" wrench to secure the Fluid Bag #12 and an Allen key to remove the bleeder cap screw.
  - **CAUTION:** *It is possible for hydraulic fluid to spray out of the Fluid Bag #12 if the bag is damaged or distorted. USE certified personal protective equipment.*
11. Unscrew the Fluid Bag Barrel #13 from the Pump Body #4A using a chain wrench or a pipe wrench and as it comes loose from the threads hold it in place.
  - As you unscrew the Fluid Bag Barrel #13 from the Pump Body #4A it is possible the Fluid Bag #12 will become loose and the hydraulic fluid will pour out through the bleeder screw hole. Check the position of the catching container.
12. Carefully lower the Fluid Bag Barrel #13 with one hand. The Fluid Bag #12 could remain in its position or it may slide down as you lower the Fluid Bag Barrel #13. As you lower the Fluid Bag Barrel #13, grab hold of the Fluid Bag #12 as it gets exposed with the other hand.
13. Hold the Fluid Bag #12 in place and lower the Fluid Bag Barrel #13 completely off and set in your clean area.

- The Fluid Bag #12 requires tipping of approximately fifteen degrees (15°) to get past the internal Hydraulic Relief Valve #8. If you hold the Fluid Bag #12 vertically it should not fall or slide off.
14. Rock the Fluid Bag #12 back and forth gently and pull it down until the Fluid Bag Seal Ring #12A is exposed.
    - Any remaining hydraulic fluid will now easily pour out through the bleeder screw hole.
  15. Slide the Fluid Bag Seal Ring #12A down and off of the Fluid Bag #12 with one hand while holding the Fluid Bag #12 in place with the other.
  16. Tip the Fluid Bag #12 approximately fifteen degrees (15°) and pull down and past the Hydraulic Relief Valve #8.
    - To determine the direction to tip the Fluid Bag #12 is simple. With the Hydraulic Hand Pump in a horizontal position and the Handle #10 on the top, you would tip the Fluid Bag #12 down.
  17. Examine the hydraulic fluid and the inside of the Fluid Bag #12 for traces of product.
    - Small quantities of product are expected but if a large quantity is found the Piston Assembly #2 should also be repaired. See “*Piston Assembly Removal and Repair*” on page nineteen (19).
  18. To be sure the Piston Assembly #2 is in its proper position repeat steps four (4), five (5), and six (6).

This completes the Fluid Bag #12 removal instructions.

If you are replacing the Hydraulic Relief Valve #8, see “*Relief Valve Replacement*” on page eighteen (18).

If you are replacing the Fluid Bag #12, continue the following instructions “*Fluid Bag Installation*”.

## Fluid Bag Installation

If you intend to re-install a previously used Fluid Bag #12, it must be able to retain its normal shape. Carefully inspect the outside surface and the sealing lip for signs of cracks and wear. Do not install if damage is apparent. Thoroughly clean all debris that may have collected on the inside surface.

You must first complete the “*Fluid Bag Removal*” on page sixteen (16).

With the Hydraulic Hand Pump still in the pipe vise as previously instructed, follow these instructions.

1. Remove the bleeder cap screw and washer from Fluid Bag #12. Use a 5/8” wrench to secure the Fluid Bag #12 and an Allen key to remove the bleeder cap screw.
2. Tip the Fluid Bag #12 approximately fifteen degrees (15°) in the same direction you previously determined to remove it.
3. Place the opening of the Fluid Bag #12 over the Hydraulic Relief Valve #8 and tip the Fluid Bag #12 vertically as you push it up.
4. Rock the Fluid Bag #12 back and forth as you push up until the sealing lip of the Fluid Bag #12 is fully inside the Pump Body #4A.
5. Slide the Fluid Bag Seal Ring #12A over the Fluid Bag #12 with the flat edge or face up until it is fully inside the Pump Body #4A.
6. Slide the Fluid Bag Barrel #13 over the Fluid Bag #12; screw it into Pump Body #4A and tighten to approximately 50 ft-lbs.
7. Remove the Hydraulic Hand Pump from the pipe vise; turn it over so the Fluid Bag #12 is up and place the Fluid Bag Barrel #13 into the pipe vise.

To refill the hydraulic system, continue on from step eleven (11) in the “*Bleeding and Filling the Hydraulic Fluid Bag*” on page fourteen (14).

## Relief Valve Replacement

The Hydraulic Relief Valve #8 should always be replaced should it fail a test. Never try to repair the Hydraulic Relief Valve #8. To replace the Hydraulic Relief Valve #8, follow these instructions:

1. Follow all instructions as described in “*Fluid Bag Removal*” on page sixteen (16).
2. Unscrew the Hydraulic Relief Valve #8 along with the Hydraulic Relief O-Ring #8A off the Pump Body #4A.
3. Install a new Hydraulic Relief O-Ring #8A onto a new Hydraulic Relief Valve #8.
4. Screw and tighten the Hydraulic Relief Valve #8 with the Hydraulic Relief O-Ring #8A on to the Pump Body #4A.
5. Follow all instructions as described in “*Fluid Bag Installation*” on page seventeen (17).

## Check Valve Repair and Replacement

A worn or defective Check Valve Assembly #6 is easily detected. As you stroke the Handle #10 and apply pressure the hydraulic system will push back onto the Handle #10. If you release the Handle #10 it will lift up on its own. When this occurs, the Check Valve Assembly #6 needs to be replaced.

1. Have a pipe vise ready and a clean area prepared where you can place parts as they are removed.
2. Open By-Pass Valve #7; check the 15,000 PSI Gauge #17B to make sure all internal pressure is relieved from the system.
3. Remove head assembly (Sealant Barrel Cap #1 and Hydraulic Pump Hose Assembly #17) from Sealant Barrel #3.
4. Remove the Handle #10 from the Fulcrum Assembly #9 and clean off any contaminants such as sand or dirt.
5. Place the Handle #10 so it is centered on the Piston Assembly #2 then push the Piston Assembly #2 to the bottom of the Sealant Barrel #3.
  - **NOTICE:** *be very careful not to scratch or score the inside of the Sealant Barrel #3.*
6. Close the By-Pass Valve #7.
7. Clean and return the Handle #10 to the Fulcrum Assembly #9 and latch into place.
8. Place a suitable container under the Hydraulic Hand Pump to catch the hydraulic fluid.
9. Place the Hydraulic Hand Pump horizontally into a pipe vise with the Check Valve Screw #6D on top. Remove the Check Valve Screw #6D and the Copper Washer #6A.
10. While holding the Hydraulic Hand Pump with one hand, loosen the pipe vise enough so the Hydraulic Hand Pump can turn or spin.
11. Place your free hand under the Hydraulic Hand Pump to catch the parts as you turn the Hydraulic Hand Pump over until the check valve cavity is down.
  - The Ball #6B, Check Valve Spring #6C and Check Valve Screen #6E should fall out. If not, tap on the Hydraulic Hand Pump lightly with a small hammer or carefully use a pointed instrument to remove these parts, **DO NOT** cause damage to the Check Valve Assembly #6 cavity or seat.
12. Turn the Hydraulic Hand Pump back over so the Check Valve Assembly #6 cavity is on top and tighten the pipe vise.
13. Using a clean, lint free towel, wipe out any remaining hydraulic fluid. Thoroughly clean out the Check the Valve Assembly #6 cavity and inspect the Check Valve Assembly #6 seat for possible damage.

- If the seat has noticeable damage it cannot be easily repaired. We recommend the Pump Body #4A be replaced.
  - When hydraulic fluid continues to fill the Check Valve Assembly #6 cavity, it indicates the Pump Piston #5C or the By-Pass Valve #7 is worn or damaged, additional repairs may be required.
14. Inspect the Ball #6B, Check Valve Spring #6C and Check Valve Screen #6E for damage and foreign material.
    - Foreign material is something other than hydraulic fluid. The presence of product could indicate a leaking or damaged Piston Assembly #2. See “*Piston Assembly Removal and Repair*” below.
  15. Replace any worn or broken parts as required.
  16. Insert the Ball #6B into the Check Valve Assembly #6 cavity.
  17. With the Ball #6B in position on the seat, use a ¼” brass punch or a cold punch and with a firm blow from a hammer, seat the Ball #6B.
  18. Turn the Hydraulic Hand Pump over and catch the Ball #6B as it falls out. Repeat step 17 until the Ball #6B does not fall out without assistance.
  19. Insert the Check Valve Screen #6E into the Check Valve Assembly #6 cavity.
  20. Insert the Check Valve Spring #6C into the Check Valve Screen #6E.
  21. Place the Copper Washer #6A over the Check Valve Screw #6D and screw into the Check Valve Assembly #6 cavity. Tighten the Check Valve Screw #6D snugly. Do not over tighten.
  22. To refill the hydraulic system, continue on from step seven (7) under “*Bleeding and Filling the Hydraulic Fluid Bag*” on page fourteen (14).

## **Piston Assembly Removal and Repair**

When hydraulic fluid is found in the Sealant Barrel #3, it indicates that the piston cups and the Piston O-Ring (#2G) could be damaged or worn out. If only a small trace of hydraulic fluid is found it is nothing to be concerned about but the hydraulic fluid should be wiped out with a clean cloth. If the amount of hydraulic fluid increases over time you may consider replacing the Piston O-Ring (#2G) and both piston cups. This is why the Sealant Barrel (#3) needs to be checked for hydraulic fluid every time you reload the pump. See “*How to Load a Hydraulic Hand Pump*” on page six (6).

To remove and repair the Piston Assembly #2, follow these instructions:

1. Have a pipe vise ready and a clean area prepared where you can place parts as they are removed.
2. Open By-Pass Valve #7; check the 15,000 PSI Gauge #17B to make sure all internal pressure is relieved from the system.
3. Remove head assembly (Sealant Barrel Cap #1 and Hydraulic Pump Hose Assembly #17) from Sealant Barrel #3.
4. Using an Allen key loosen Cap Screw #16H. Hold the Latch Arm # 16E securely with one hand and remove the Cap Screw #16H.
  - As you unscrew the Cap Screw #16E the Latch Spring #16F will want to push away from the pump. Hold the Latch Arm #16E tight to the Cap Screw #16H and remove all parts together as a unit. DO not separate the parts until the Latch Spring #16F is free and away from the pump and take care not to drop or loose these small pieces.
5. Remove the Handle #10 from the Fulcrum Assembly #9 and clean off any contaminants such as sand or dirt.

6. Place the Handle #10 so it is centered on the Piston Assembly #2 then push the Piston Assembly #2 to the bottom of the Sealant Barrel #3.
  - Place Handle #10 in the clean area.
  - **NOTICE:** *be very careful not to scratch or score the inside of the Sealant Barrel #3.*
7. Carefully place the Pump Body Assembly #4 into a pipe vise in a vertical position with the Sealant Barrel #3 up and loosen the Sealant Barrel #3 using a chain wrench or a pipe wrench. Close the By-Pass Valve #7 then completely remove the Sealant Barrel #3.
  - **IMPORTANT:** *when removing the Sealant Barrel #3 notice the groove for the Barrel O-Ring #3B at the end of the Sealant Barrel #3. We will later refer to this as the o-ring end and the opposite end as the head assembly end.*
  - **CAUTION:** *using the Handle #10 to twist the Pump Body Assembly #4 will damage the Hydraulic Hand Pump.*
8. Remove the Pump Body Assembly #4 from the pipe vise and place the Sealant Barrel #3 into the pipe vise.
  - Stand the Hydraulic Hand Pump on the Fluid Barrel Cap #14 in a safe place where it will not fall or get knocked over.
9. Using the Handle #10 push the Piston Assembly #2 out of the Sealant Barrel #3 enough so you can grab it and pull it out with your hand.
10. Clean and return the Handle #10 to the clean area.
11. While holding the Piston Body #2F using a pin spanner, remove both Washer Nuts #2D using a face spanner.



12. Remove and discard the Inner Leather Cup #2H and the Nylon Piston Cup #2E.
13. Replace the Piston O-Ring #2G.
14. While holding the Piston Body #2F with the Cap Screw #2A up place the Nylon Piston Cup #2E on top and the Inner Leather Cup #2H on the bottom of the Piston Body #2F.
15. Screw a washer nut #2D to each end of the piston body #2F.
16. Tighten the Piston Assembly #2 using the spanner wrenches.
17. Rub a thin coat of hydraulic fluid over the outside of the Inner Leather Cup #2H.
18. Place the Piston Assembly #2 with the Inner Leather Cup #2H into the head assembly end of the Sealant Barrel #3.
  - Slowly work the Inner Leather Cup #2H into the Sealant Barrel #3 and avoid damaging it.
  - **NOTICE:** *you may need to tap gently on the edge of the Inner Leather Cup #2H using a ball peen hammer to assist in working it in. The leather will regain its shape when soaked with hydraulic fluid.*

19. Once the Inner Leather Cup #2H has started going into the Sealant Barrel #3 wipe all of the remaining Piston Assembly #2 with hydraulic fluid then push the Piston Assembly #2 into the Sealant Barrel #3.
  - **IMPORTANT:** use the Handle #10 to push the Piston Assembly #2 back and forth several times to help break the new parts in.
20. Place the Handle #10 so it is centered on the Piston Assembly #2 then push the Piston Assembly #2 so the Inner Leather Cup #2H is level with the o-ring end of Sealant Barrel #3.
21. Remove the Sealant Barrel #3 from the pipe vise and place the Pump Body Assembly #4 vertically into the pipe vise as it was previously.
22. If required, replace the Barrel Gasket #3A and the Barrel O-Ring #3B with new parts.
23. Thread the end of Sealant Barrel #3 into the Body Assembly #4. Once you feel the Sealant Barrel #3 makes contact with the Barrel O-Ring #3B, back off the Sealant Barrel #3 one-half (½) turn.
24. Place Handle #10 into the Fulcrum #9 and stroke the pump until hydraulic fluid is seen leaking at the threads.
  - If no fluid is detected after a few strokes, back off the Sealant Barrel #3 an additional ½ turn and stroke the pump again. Repeat this until hydraulic fluid is detected leaking at the threads.
25. Tighten the Sealant Barrel #3 and wipe the pump clean of the leaked hydraulic fluid.
26. Open the By-Pass Valve #7.
27. Use the Handle #10 to push the Piston Assembly #10 completely to the end of the Sealant Barrel #3.
28. Close the By-Pass Valve #7.
29. Reattach the Handle Latch Assembly #16.
  - Follow steps 1 through 8 of “To reassemble the Handle Latch Assembly” in the “Handle Latch Repair and Replacement” instructions on page twenty-six (26).
30. To refill the hydraulic system, continue on step seven (7) under “Bleeding and Filling the Hydraulic Fluid Bag” on page fourteen (14).

## Pump Piston Cartridge Repair and Replacement

A worn Pump Piston #5C and Hydraulic Pump Cylinder #5 can be easily detected when the Handle #10 travels freely down before you feel the force of the hydraulic fluid. The more it travels without any force, the more they are worn. The more worn they are, the longer it will take to service a valve. It is recommended that the assembly be replaced if the Handle #10 can travel more than half its swing before feeling the pressure of hydraulic fluid. Carefully examine the Linkage Assembly #11 and the Pump Piston #5C as you stroke. A worn Linkage Assembly #11 can be misinterpreted as pump piston cartridge wear.

Follow these instructions:

1. Open By-Pass Valve #7; check the 15,000 PSI Gauge #17B to make sure all internal pressure is relieved from the system.
2. Remove head assembly (Sealant Barrel Cap #1 and Hydraulic Pump Hose Assembly #17) from Sealant Barrel #3.
3. Remove the Handle #10 from the Fulcrum Assembly #9 and clean off any contaminants such as sand or dirt.
4. Place the Handle #10 so it is centered on the Piston Assembly #2 then push the Piston Assembly #2 to the bottom of the Sealant Barrel #3.
  - **NOTICE:** be very careful not to scratch or score the inside of the Sealant Barrel #3.



5. Clean and return the Handle #10 to the Fulcrum Assembly #9.
6. Pull back the Stem and Knob #16A to release the Handle #10.
7. Lift the Handle #10 up until it reaches its full height.
8. Remove the Bolt #11B and Lock Nut #11D that goes through the Fulcrum Link #11E, through the top of the Pump Piston #5C and through the Fulcrum Assembly #9.
9. Remove the Bolt #11B and Lock Nut #11D that goes through the Links 11A and through the Pump Body #4A.
10. Place the Handle #10 and Fulcrum Assembly #9 to one side.
11. Place the Hydraulic Hand Pump in a pipe vise by the Fluid Barrel #13 with the Sealant Barrel #3 up.
12. Place a suitable container under the Hydraulic Hand Pump to catch any spilled hydraulic fluid.
13. Pull the Pump Piston #5C out of the Hydraulic Pump Cylinder #5.
14. Unscrew the Hydraulic Pump Cylinder #5 with a spanner pin wrench (The cylinder cavity will probably leak a small amount of hydraulic fluid).
15. Using an o-ring tool, replace the Bottom Cylinder O-Ring #5B at the bottom of the Hydraulic Pump Cylinder #5 cavity in the Pump Body #4A.
16. Using an o-ring tool replace the Pump Piston O-Ring #5D inside the top of the Hydraulic Pump Cylinder #5.
17. Place the Cylinder Neck O-Ring #5A on the Hydraulic Pump Cylinder #5.
18. Screw the Hydraulic Pump Cylinder #5 into the Pump Body #4A and tighten with a spanner pin wrench.
19. Rub a thin coat of hydraulic fluid over the Pump Piston #5C and push into the Hydraulic Pump Cylinder #5.
20. Reconnect the Fulcrum #9 and Handle #10 to the Pump Body #4A.
21. Reattach the head assembly.
22. Follow the “*Bleeding and Filling the Hydraulic Fluid Bag*” instructions on page fourteen (14).

## By-Pass Valve Repair and Replacement

A faulty By-Pass Valve #7 will not allow hydraulic pressure to build up in the Hydraulic Hand Pump. Hydraulic fluid will return into the Fluid Bag #12 and / or leak past the By-Pass Valve O-Ring #7C depending on the extent of the damage.

1. Open By-Pass Valve #7; check the 15,000 PSI Gauge #17B to make sure all internal pressure is relieved from the system.
2. Remove head assembly (Sealant Barrel Cap #1 and Hydraulic Pump Hose Assembly #17) from Sealant Barrel #3.
3. Remove the Handle #10 from the Fulcrum Assembly #9 and clean off any contaminants such as sand or dirt.
4. Place the Handle #10 so it is centered on the Piston Assembly #2 then push the Piston Assembly #2 to the bottom of the Sealant Barrel #3.
  - **NOTICE:** *be very careful not to scratch or score the inside of the Sealant Barrel #3.*
5. Clean and return the Handle #10 to the Fulcrum Assembly #9.
6. Place the Hydraulic Hand Pump in a pipe vise by the Fluid Barrel #13 with the Sealant Barrel #3 up.

7. Place a suitable container under the Hydraulic Hand Pump to catch any spilled hydraulic fluid.
8. Remove the By-Pass Stop Screw #7B and the By-Pass Valve Stop #7A.
9. Unscrew the By-Pass Valve #7 and pull out.
10. Inspect deep in the By-Pass Valve #7 cavity for damage to the By-Pass Valve #7 seat and remove any foreign objects/debris.
  - If damage exists to the By-Pass Valve #7 seat, the Pump Body #4A needs to be replaced.
11. Place the By-Pass Valve O-Ring #7C on the new By-Pass Valve #7.
12. Carefully screw the By-Pass Valve #7 into the Pump Body #4A until the By-Pass Valve O-Ring #7C engages the Pump Body #4A.
  - To avoid damage to the By-Pass Valve O-Ring #7C, Screw the By-Pass Valve #7 in 1/2 turn, and unscrew 1/4 turn. Repeat this procedure until the By-Pass Valve O-Ring #7C has entered the Pump Body #4A and the By-Pass Valve #7 has seated.
13. To refill the hydraulic system, continue on step seven (7) under "*Bleeding and Filling the Hydraulic Fluid Bag*" on page fourteen (14).

## Sealant Barrel O-Ring and Gasket Replacement

1. Open By-Pass Valve #7; check the 15,000 PSI Gauge #17B to make sure all internal pressure is relieved from the system.
2. Remove head assembly (Sealant Barrel Cap #1 and Hydraulic Pump Hose Assembly #17) from Sealant Barrel #3.
3. Remove the Handle #10 from the Fulcrum Assembly #9 and clean off any contaminants such as sand or dirt.
4. Place the Handle #10 so it is centered on the Piston Assembly #2 then push the Piston Assembly #2 to the bottom of the Sealant Barrel #3.
  - **NOTICE:** *be very careful not to scratch or score the inside of the Sealant Barrel #3.*
5. Clean and return the Handle #10 to the Fulcrum Assembly #9.
6. Close the By-Pass Valve #7.
7. Using an Allen key, loosen Cap Screw #16H. Hold the Latch Arm # 16E securely with one hand and remove the Cap Screw #16H.
  - As you unscrew the Cap Screw #16E the Latch Spring #16F will want to push away from the pump. Hold the Latch Arm #16E tight to the Cap Screw #16H and remove all parts together as a unit. DO not separate the parts until the Latch Spring #16F is free and away from the pump and take care not to drop these small pieces.
8. Carefully place the Hydraulic Hand Pump in a pipe vise by the Pump Body Assembly #4 with the Sealant Barrel #3 up.
9. Place a suitable container under the Hydraulic Hand Pump to catch any spilled hydraulic fluid.
10. Unscrew the Sealant Barrel #3 from the Pump Body #4A and place in a clean dry area.
  - **IMPORTANT:** *when removing the Pump Body Assembly #4 notice the groove for the Barrel O-Ring #3B at the end of the Sealant Barrel #3. We will later refer to this as the o-ring end and the opposite end as the head assembly end.*
11. Using o-ring tools, remove and replace the Barrel O-Ring #3B in the Pump Body #4A.

12. Thread the o-ring end of Sealant Barrel #3 into the Body Assembly #4. Once you feel the Sealant Barrel #3 makes contact with the Barrel O-Ring #3B back off the Sealant Barrel #3 1/2 turn.
13. Stroke the pump until hydraulic fluid is seen leaking at the threads.
  - If no fluid is detected after a few strokes, back off the Sealant Barrel #3 an additional 1/2 turn and stroke the pump again. Repeat this until hydraulic fluid is detected leaking at the threads.
14. Tighten the Sealant Barrel #3 and wipe the pump clean of the leaked hydraulic fluid.
15. Open the By-Pass Valve #7.
16. Use the Handle #10 to push the Piston Assembly #10 completely to the end of the Sealant Barrel #3.
17. Remove and replace the Barrel Gasket #3A from inside the Sealant Barrel Cap #1.
18. Reattach the Handle Latch Assembly #16.
  - Follow steps 1 through 8 of *“To reassemble the Handle Latch Assembly”* in the *“Handle Latch Repair and Replacement”* instructions on page twenty-six (26).
19. To refill the hydraulic system, continue on step seven (7) under *“Bleeding and Filling the Hydraulic Fluid Bag”* on page fourteen (14).

## Hose Assembly Replacement

It is highly recommended the Extra High-Pressure Hose #17E be replaced every 3 years and any other components in the Hydraulic Pump Hose Assembly #17 that are worn.

Use only Sealweld Extra High-Pressure Hoses, components and parts.

To remove the Hydraulic Pump Hose Assembly #17, follow these instructions.

1. Open By-Pass Valve #7; check the 15,000 PSI Gauge #17B to make sure all internal pressure is relieved from the system.
2. Clamp the Hydraulic Hand Pump into a pipe vise.
3. Using a proper fitting wrench, remove the Hydraulic Pump Hose Assembly #17 from Sealant Barrel Cap #1. Replace and / or reuse Hydraulic Pump Hose Assembly #17 parts as needed.
4. Attach and tighten the new Hydraulic Pump Hose Assembly #17 to the Sealant Barrel Cap #1.

## Pressure Gauge Replacement

Occasionally sealant will enter the 15,000 PSI Gauge #17B bourdon tube and it will fail to return to (0 PSI) zero. If this occurs, the 15,000 PSI Gauge 17B needs to be replaced. Follow these instructions.

1. Open By-Pass Valve #7; check the 15,000 PSI Gauge #17B to make sure all internal pressure is relieved from the system.
  - Make sure all pressure sources have been eliminated.
2. Clamp the Hydraulic Hand Pump into a pipe vise.
3. Using a proper fitting wrench remove the Hydraulic Pump Hose Assembly #17 from Sealant Barrel Cap #1.
4. Remove the Hydraulic Hand Pump from the pipe vise and clamp the Hydraulic Pump Hose Assembly #17 into the pipe vise by the High-Pressure TEE #17C with the 15,000 PSI Gauge #17B up.
5. Using a proper fitting wrench, remove and discard the 15,000 PSI Gauge #17B.
6. Fill the bourdon tube of the new 15,000 PSI Gauge #17B with a light weight hydraulic fluid.

- Use a thin pointed instrument to remove any air bubbles that are trapped in the bourdon tube and continue to fill. Repeat as required until the bourdon tube is full
7. Dig a large quantity of product out of the High-Pressure TEE #17C to form a cavity and fill it with a light weight hydraulic fluid.
    - This is not required if the High-Pressure TEE #17C has been replaced and is empty.
  8. Attach and tighten the new 15,000 PSI Gauge #17B into the High-Pressure TEE #17C.
  9. Remove the Hydraulic Pump Hose Assembly #17 from the pipe vise and clamp the Hydraulic Hand Pump into the pipe vise.
  10. Attach and tighten the Hydraulic Pump Hose Assembly #17 to the Sealant Barrel Cap #1.
  11. Follow the instructions “*Testing the Pump*” on page thirty-three (33) to verify the new 15,000 PSI Gauge #17B is working properly.

## Linkage Assembly Repair and Replacement

There is not a lot that can go wrong with the Linkage Assembly #11 and in most cases, bent parts can be straightened using a hammer and an anvil. Most wear happens to Bolts #11B that are easily replaceable.

To **disassemble** the Linkage Assembly #11, follow these instructions:

1. Open By-Pass Valve #7; check the 15,000 PSI Gauge #17B to make sure all internal pressure is relieved from the system.
  - Make sure all pressure sources have been eliminated.
2. Pull back the Stem and Knob #16A to release the Handle #10.
3. Using an Allen key and a wrench, remove the Lock Nut #11D and Bolt #11B that passes through the Fulcrum Link #11E, the Fulcrum Assembly #9 and the Pump Piston #5C.
4. Using an Allen key and a wrench, remove the Lock Nut #11D and Bolt #11B that passes through the Links #11A and the Fulcrum Assembly #9.
  - Place the Fulcrum Assembly #9 and Handle #10 aside.
5. Using an Allen key and a wrench remove the Lock Nut #11D and Bolt 11B that passes through the Fulcrum Link #11E, Links #11A and the Body #4A.
6. Replace damaged Links #11 and Fulcrum Link #11E.
  - You can use a hammer and an anvil to straighten these parts if they are bent.
  - Inspect all holes in these Links for wear. If any holes are oblong, the part should be replaced. Inspect the Fulcrum Link #11E slot for wear. If excessive wear is present, replace the Fulcrum Link #11E.
7. Inspect all Bolts #11B for excessive wear and replace as required.
  - The amount of wear on the Bolts #11B effects how much play is in the stroke. It is good practice to always replace all Bolts #11B and Lock Nuts #11D before reassembling.

To **reassemble** the Linkage Assembly #11, follow these instructions:

1. Place a Link #11A on each side of the Fulcrum Assembly #9 with the angle cut up and facing the Fulcrum Assembly #9.
  - The top of Links #11A are cut at an angle to allow the Fulcrum Assembly #9 to pivot without contacting the Links #11A.

2. Slide first Bolt #11B through the top hole of Links #11A and through the Fulcrum Assembly #9.
3. Screw on first Lock Nut #11D and tighten using an Allen key and a wrench so Links #11A are snug but loose enough to move easily.
  - Over tightening will cause the Handle #10 to be difficult to stroke. Leaving it too loose will make the Handle #10 sloppy when stroking. This applies to all Linkage Assembly #11 parts.
4. Place the Fulcrum Assembly #11 over the Hydraulic Hand Pump with Links #11A on each side of the Body #4.
5. Slide second Bolt #11B through the bolt hole in Fulcrum Link #11E then slide the Bolt #11B through Links #11A and the Body #4.
  - The Fulcrum Link #11E needs to be at a 45° (Forty-five degree) angle as shown in illustration on page twenty-nine (29).
6. Screw on second Lock Nut #11D and tighten using an Allen key and a wrench so Links #11A are snug but loose enough to move easily.
7. Slide third Bolt #11B through the slot in Fulcrum Link #11E and through the hole in Pump Piston #5C.
8. Screw on third Lock Nut #11D and tighten using an Allen key and a wrench so Links #11A are snug but are loose enough to move easily.
9. Connect the Latch Arm #16E to the Stem and Knob #16A.
10. Close By-Pass Valve #7

## Handle Latch Repair and Replacement

The Handle Latch Assembly #16 can become damaged by rough handling and by not fully engaging the Stem and Knob #16A into the Latch Arm #16E. Swinging the Latch Arm # 16E further then necessary can over stretch the Latch Spring #16F and will eventually bend or break it. Only swing the Latch Arm #16E enough to fully engage the Stem and Knob #16A to secure the Handle #10.

To disassemble the Handle Latch Assembly #16, follow these instructions:

1. Lay the Hydraulic Hand Pump on its side onto a workbench or flat surface with the By-Pass Valve #7 facing up.
2. Open By-Pass Valve #7; check the 15,000 PSI Gauge #17B to make sure all internal pressure is relieved from the system.
  - Make sure all pressure sources have been eliminated.
3. Pull back the Stem and Knob #16A to release the Handle #10. Lift the Handle #10 up away from the pump.
4. Using an Allen key loosen Cap Screw #16H. Hold the Latch Arm # 16E securely with one hand and remove the Cap Screw #16H.
  - As you unscrew the Cap Screw #16E the Latch Spring #16F will want to push away from the pump. Hold the Latch Arm #16E tight to the Cap Screw #16H and remove all parts together as a unit. **DO NOT** separate the parts until the Latch Spring #16F is free and away from the pump and take care not to drop these small pieces.
  - If the Latch Arm #16E has been bent, use a hammer and an anvil to straighten to its original shape.
5. Using an Allen key and a wrench, remove the Lock Nut #11D and Bolt #11B that passes through the Fulcrum Link #11E, the Fulcrum Assembly #9 and the Pump Piston #5C.

6. Using an Allen key and a wrench, remove the Lock Nut #11D and Bolt #11B that passes through the Links #11A and the Fulcrum Assembly #9.
7. The Fulcrum Assembly #9 and Handle #10 are now detached from the Hydraulic Hand Pump. Turn the Fulcrum Assembly #9 over and place on bench with the Stem and Knob #16A facing up.
8. Using a wrench, unscrew the Latch Screw #16B and slide the Stem and Knob #16A, Stem Spring #16C and Retainer #16D out of the Fulcrum Assembly #9.
9. Hold the Stem and Knob #16A in one hand with the knob in the palm of your hand. Slide back to compress the Stem Spring #16C and hold back with fingers from same hand.
  - The Stem Spring #16C needs only to be compressed enough to assist in the removal of the Retainer #16D.
10. Remove the Retainer #16D and slide the Stem Spring #16C and Latch Screw #16B off the Stem and Knob #16A.

To reassemble the Handle Latch Assembly #16, follow these instructions:

1. Inspect, repair or replace worm or defective parts as required.
2. Refer to the illustration on page twenty-nine (29) to properly orient the Latch Arm #16E positioning to the Body #4A.
3. Slide Latch Sleeve #16G over the threads of Cap Screw #16H.
4. Place the Latch Arm #16E into the bent end of the Latch Spring #16F. The Latch Spring #16F should sit flat against the Latch Arm #16E.
5. Position the Latch Spring #16E so it is centered over the lower hole of the Latch Arm #16E and slide the Cap Screw #16H and Latch Sleeve #16G into the hole.
6. With the Hydraulic Hand Pump lying horizontally and the By-Pass Valve #7 towards you, position the Latch Arm #16E against the Sealant Barrel #3 on the By-Pass Valve #7 side of the pump and the Cap Screw #16H towards the threaded hole.
7. While in position, hold the parts together with one hand and use needle nose pliers to grab the straight end of the Latch Spring #16F. Wind the Latch Spring #16F counter-clockwise until the end passes over the top of Sealant Barrel #3.
  - *CAUTION: take care not to bend the wire of the Latch Spring #16F.*
8. While holding the assembly tight to the Sealant Barrel #3 slide it forward and thread Cap Screw #16H into the hole and tighten.
  - The Latch Arm #16E should be snug and firm against the Sealant Barrel #3 by the Latch Spring #16F.
9. Slide Latch Screw #16B, threaded end away from the stem knob onto Stem and Knob #16A.
10. Slide Stem Spring #16C onto Stem and Knob #16A.
11. Hold the Stem and Knob #16A in one hand with the knob in the palm of your hand. Slide back to compress the Stem Spring #16C and hold back with fingers from same hand. Attach the Retainer #16D.
12. With the Handle #10 pointing away slide the Stem and Knob #16A into the Fulcrum Assembly #9 and tighten Latch Screw #16B.

---

## Storing the Hydraulic Hand Pump

It is important to properly prepare the Hydraulic Hand Pump for storage if it will not be used for a long period of time. Because the hydraulic Fluid Bag #12 is made of a rubber material, it is vulnerable to distortion when all or most of the hydraulic fluid is in the Sealant Barrel #3.

To help prevent this distortion from occurring it is recommended that the Hydraulic Hand Pump be fully loaded with product or that the Piston Assembly #2 is completely pushed down into the Sealant Barrel #3.

To store the Hydraulic Hand Pump fully loaded, see “*How to Load a Hydraulic Hand Pump*” on page six (6).

To store the Hydraulic Hand Pump empty, follow these instructions:

1. Detach the Giant Buttonhead Coupler #17G from the fitting on the valve.
  - **NOTICE:** Always relieve any internal pressure by opening the By-Pass Valve #7 one full turn before detaching the Giant Buttonhead Coupler #17G from the fitting on a valve.
2. Close By-Pass Valve #7 by turning it clockwise until it is snug, and only hand-tight.
3. Pull back the Stem and Knob #16A to release the Handle #10.
4. Lift the Handle #10 up until it reaches its full height.
5. Pull the Handle #10 all the way down. Steps four (4) and five (5) together is a stroke.
6. Stroke the Handle #10 until Sealant Barrel #3 is empty of all product.
7. Open By-Pass Valve #7 to relieve any internal pressure by turning it counter-clockwise one (1) full turn.
8. Look at the 15,000 PSI Gauge #17B to make sure the pressure is (0 PSI) zero.
9. Remove the head assembly (Sealant Barrel Cap #1 and Hydraulic Pump Hose Assembly #17) from Sealant Barrel #3.
  - If the head assembly will not unscrew easily, double check to make sure By-Pass Valve #7 is open. The Handle #10 may be used to increase leverage, the stub on the Sealant Barrel Cap #1 fits into the hole at the end of the Handle #10.
10. Place the head assembly in a clean, dry place to avoid any contamination.
11. Place the Hydraulic Hand Pump on the floor in an upright position with the Sealant Barrel #3 at the top.
12. Clean off any contaminants such as sand or dirt from the Handle #10.
13. Place the Handle #10 so it is centered on the Piston Assembly #2 then push the Piston Assembly #2 to the bottom of the Sealant Barrel #3.
  - **NOTICE:** be very careful not to scratch or score the inside of the Sealant Barrel #3.
14. Return the Handle #10 to the Fulcrum Assembly #9.
15. Connect the Latch Arm #16E to the Stem and Knob #16A.
16. Attach the head assembly onto Sealant Barrel #3,
17. Close By-Pass Valve #7

The Hydraulic Hand Pump is now ready for storage.

# Parts Guide

## Parts Illustration

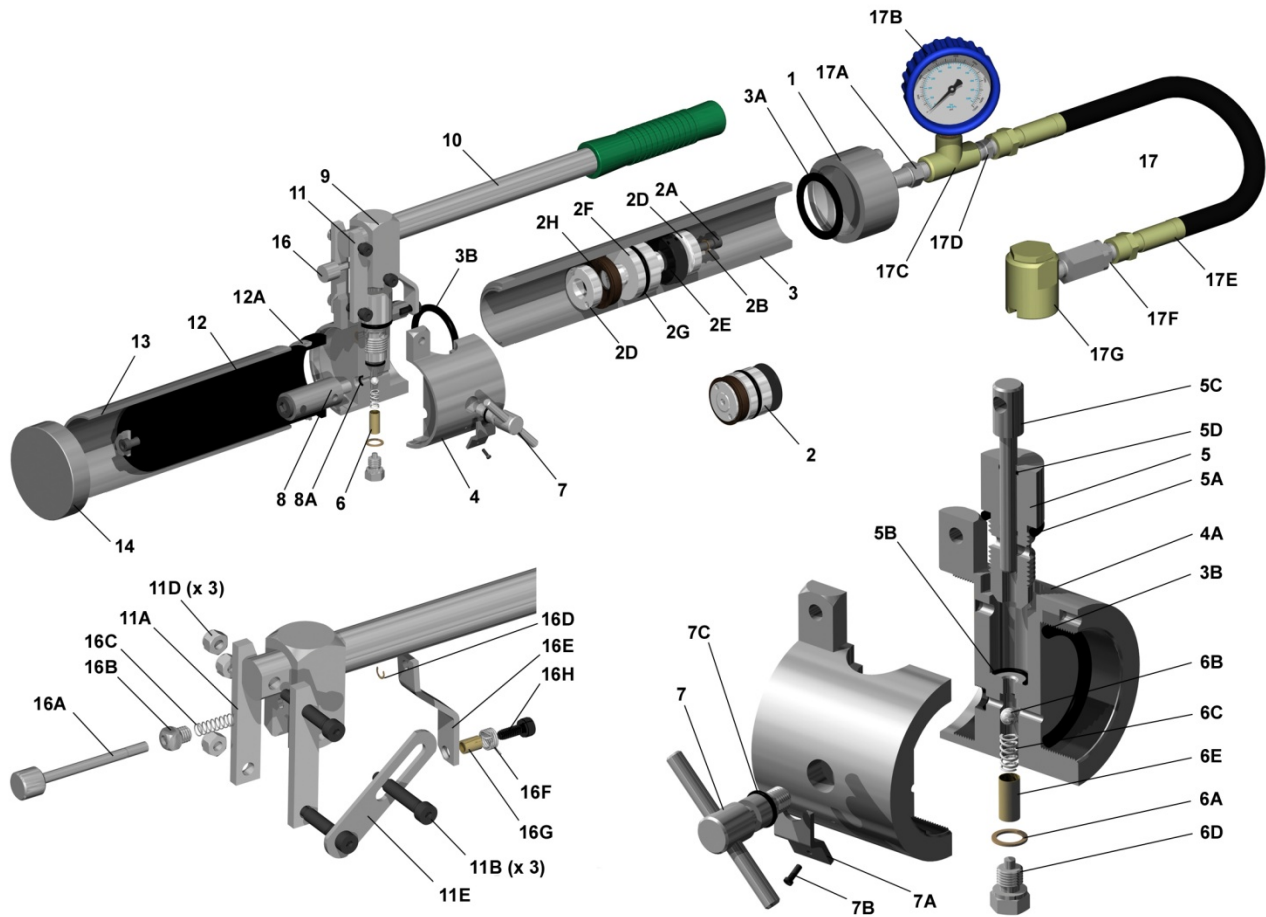

*The image above contains an NGRain model with an animation showing the disassembly and assembly of the Hydraulic Hand Pump.*



## Parts List

Illustration #	Description	Order Part #	Qty. Req'd
1	Sealant Barrel Cap	R-HG07	1
2	Piston Assembly	R-HG08	1
2A	Cap Screw	R-HG08A	1
2B	Copper Washer	R-HG08BA	1
2D	Washer Nut	R-HG08C	2
2E XX	Nylon Piston Cup	R-A8-20C	1
2F	Piston Body	R-HG08E	1
2G X	Piston O-Ring	R-A8-20E	1
2H XX	Inner Leather Cup	R-HG08H	1
3	Sealant Barrel	R-HG09	1
3A XX	Barrel Gasket	R-HG10A	1
3B X	Barrel O-Ring – Nitrile	R-A8-19C	1
4	Pump Body Assembly	R-HG11	1
4A	Pump Body - Bare	R-HG11A	1
5 XXX	Hydraulic Pump Cylinder	R-HG11B	1
5A X	Cylinder Neck O-Ring - Nitrile	R-HG11C	1
5B X	Bottom Cylinder O-Ring - Nitrile	R-HG11D	1
5C XXX	Pump Piston	R-HG11E	1
5D X	Pump Piston O-Ring	R-HG08B	1
6 XX	Check Valve Assembly	R-HG11F	1
6A	Copper Washer	R-HG11FA	1
6B	Ball – ¼"	R-HG11FB	1
6C	Check Valve Spring	R-HG11FC	1
6D	Check Valve Screw	R-HG11FD	1
6E	Check Valve Screen	R-HG11FE	1
7 XX	By-Pass Valve	R-HG11G	1
7A	By-Pass Valve Stop	R-HG11H	1
7B	Cap Screw	R-HG11I	1
7C X	By-Pass Valve O-Ring - Nitrile	R-HG31	1
8	Hydraulic Relief Valve	R-HG11J	1
8A X	Hydraulic Relief O-Ring - Nitrile	R-HG11K	1
9	Fulcrum Assembly	R-HG12	1
10	Handle	R-HG13	1
11	Linkage Assembly	R-HG14	1
11A	Link	R-HG14A	2
11B	Bolts	R-HG14B	3
11D	Lock Nuts	R-HG14C	3
11E	Fulcrum Link	R-HG14E	1

Illustration #	Description	Order Part #	Qty. Req'd
XX	Hydraulic Fluid	R-HOPINT	1
12 XX	Fluid Bag	R-HG15	1
12A	Fluid Bag Seal Ring	R-HG15A	1
13	Fluid Bag Barrel	R-HG16	1
14	Fluid Bag Barrel Cap	R-HG17	1
16	Handle Latch Assembly	R-HG30	1
16A	Stem & Knob	R-HG30A	1
16B	Latch Screw	R-HG30B	1
16C	Stem Spring	R-HG30C	1
16D	Retainer	R-HG30D	1
16E	Latch Arm	R-HG30E	1
16F	Latch Spring	R-HG30F	1
16G	Latch Sleeve	R-HG30G	1
16H	Cap Screw	R-HG30H	1
17	Hydraulic Pump Hose Assembly	H-H-HOSE	1
17A	Adapter - 1/4" M X 1/4" M	H-AD-4M4M	1
17B	15,000 PSI Gauge with Guard	H-GD-01C	1
17C	High-Pressure TEE - 1/4"	H-T-444	1
17D	Adapter - 1/4" M x 1/2" - 27 M	H-AD-4M7M	1
17E	Extra High-Pressure Hose - 18"	H-HS-18XHP	1
17F	Straight Swivel 1/4" M X 1/2"-27M	H-SV-ST1	1
17G	Giant Buttonhead Coupler	H-CPSG-2	1
X	O-Ring Repair Kit	R-HGOREP	1
XX	Minor Repair Kit	R-HGMIN	1
XXX	Major Repair Kit	R-HGMAJ	1

Please note:

**X** includes all parts with a single **X** illustration number.

**XX** includes all parts with a single **X** AND all parts with a double **X** illustration number.

**XXX** includes all parts with a single **X**, double **X** and triple **X** illustration number.

## How to Order Hydraulic Hand Pump Parts

Parts can be identified by referring to the illustration number. You can then cross reference the illustration number with the part number using the Parts List provided above. Ordering parts by the part number is the best way to ensure you will receive the required part.. Contact the nearest Sealweld location by phone, fax or email to order parts.

### Repair Kits

<b>O-Ring Repair Kit</b>		<b>R-HGOREP</b>
This kit contains all the o-ring you'll need to extend the service life of the Hydraulic Hand Pump. This kit includes the following:		
Illustration #	Description	Qty. Req'd
2G	Piston O-Ring	1
3B	Barrel O-Ring – Nitrile	1
5A	Cylinder Neck O-Ring – Nitrile	1
5B	Bottom Cylinder O-Ring – Nitrile	1
5D	Pump Piston O-ring	1
7C	By-Pass Valve O-Ring – Nitrile	1
8A	Hydraulic Relief O-Ring – Nitrile	1

<b>Minor Repair Kit</b>		<b>R-HGMIN</b>
The Minor Repair Kit includes all the parts required to repair or replace the sub-assemblies of the Hydraulic Hand Pump. The Minor Repair Kit includes the O-ring Repair Kit plus the following:		
Illustration #	Description	Qty. Req'd
2E	Nylon Piston Cup	1
2H	Inner Leather Cup	1
3A	Barrel Gasket	1
6	Check Valve Assembly	1
7	By-Pass Valve	1
12	Fluid Bag	1
	Hydraulic Fluid	1

<b>Major Repair Kit</b>		<b>R-HGMAJ</b>
This complete kit is ideal The Major Repair Kkit includes the O-ring and Minor Repair Kits plus the following:		
Illustration #	Description	Qty. Req'd
5	Hydraulic Pump Cylinder	1
5C	Pump Piston	1

<b>Test Fitting</b>		<b>R-F-TEST</b>
This blank buttonhead fitting is used to perform the test procedure found in the Trouble shooting section of this manual.		
Illustration #	Description	Qty. Req'd
	Sealweld Sealant Pump Test Fitting	1

# Troubleshooting

---

## Troubleshooting the Hydraulic Hand Pump

Your Sealweld Hydraulic Hand Pump has been factory pre-tested using the testing procedure below and is ready to use right out of the box. It is not necessary to test a brand new pump however the Hydraulic Hand Pump should be tested periodically to assure all parts are working BEFORE working on a valve under pressure.

The following test procedure has been developed to be used strictly on a Hydraulic Hand Pump. Performing this test on a similar style pump may result in damage to the equipment and / or personal injury.

**ALWAYS** wear proper Personal Protective Equipment while performing this test.

If you are not comfortable in performing this test or if it does not resolve a problem you are experiencing with the Hydraulic Hand Pump, contact a Sealweld service center near you.

### Testing the Pump

*This test procedure is based on the Hydraulic Hand Pump Sealant Barrel #3 being empty before starting.*

**IMPORTANT:** Be sure you have read and understand the “*Safety Considerations*” section of this manual before testing the pump.

Test the Hydraulic Hand Pump by follow these instructions:

This test requires the use of a Sealweld Sealant Pump Test Fitting. See “*Repair Kits*”.

Perform this test with the Hydraulic Hand Pump placed in a horizontal position until otherwise told different.

1. Inspect the Hydraulic Hand Pump for signs of leaking hydraulic fluid.
  - If at any time during this test hydraulic fluid is found leaking from the pump, it must be traced to the source and corrected. The test should then be restarted.
2. Follow the “*Bleeding and Filling the Hydraulic Fluid Bag*” instructions on page fourteen (14).
  - This will remove any trapped air and eliminate it as a cause of pump failure.
3. Follow the Loading instructions provided. See “*How to Load a Hydraulic Hand Pump*” on page six (6).
  - **CAUTION:** *Load the Hydraulic Hand Pump with a heavy valve sealant product such as Sealweld’s Total-Lube #911. DO NOT USE light valve lubricants, cleaners or liquid products to perform this test. Lighter products can shoot out at extremely high pressure should an equipment failure occur.*
4. Open By-Pass Valve #7 to relieve any internal pump pressure by turning it counter-clockwise one (1) full turn.
5. Check that the 15,000PSI Gauge #17B reads zero (0) PSI.
  - If the 15,000 PSI Gauge #17B does not return to a zero (0) reading and you are sure there is no pressure, it indicates product has entered the 15,000 PSI Gauge #17B bourdon tube. See “*Pressure Gauge Replacement*” on page twenty-four (24).

6. Close the By-Pass Valve #7.
  - **NEVER** over tighten By-Pass Valve #7. It should only be hand tight and snug.
7. Pull back the Stem and Knob #16A to release the Handle #10.
8. Stroke the Handle #10 several times to check if sealant gets dispensed out of the Giant Buttonhead Coupler #17G. Fifty (50) strokes should dispense approximately one (1) ounce of sealant.
  - A stroke is defined by lifting the Handle #10 up until it reaches its full height, waiting one (1) second and then pull the Handle #10 all the way down.
  - If no product, or only a small amount of product is dispensed with each stroke, or if fifty (50) strokes dispenses less than one (1) ounce of product:
    - i. See *“By-Pass Valve Repair and Replacement”*
    - ii. See *“Pump Piston Repair and Replacement”*
  - **NOTE:** Place the Giant Buttonhead Coupler #17G into a container or on a rag to catch sealant as it dispenses out.
9. Visually inspect the Linkage Assembly #11 for any bent or damaged parts and excessive play.
  - Open the By-Pass Valve #7. Lift the Handle #5 up until it reaches its full height. Examine how far the Handle #10 can move up and down without the Pump Piston #5C moving. Excessive movement indicates the Linkage Assembly #11 is badly worn and requires replacing. When factory tested, there is no noticeable play in the Linkage Assembly #11. See *“Replacing the Linkage Assembly”*.
10. Pull the Handle #10 down and close the By-Pass Valve #7.
  - It is important that the By-Pass Valve #7 is closed firm but only hand tight before proceeding.
11. Attach the Giant Buttonhead Coupler #17G to the Test Fitting.
  - **IMPORTANT:** If at any time during the remainder of this test, when pressure is generated in the Hydraulic Hand Pump and the Handle #10 wants to springs back or push up against the stroke, it indicates a failure in the Check Valve Assembly #6. See *“Repair or Replacing the Check Valve”*.
  - **IMPORTANT:** If at any time during the remainder of this test, stroking the Handle #10 stops generating pressure;
    - i. Tilt the pump vertically, pointing the Hydraulic Pump Hose Assembly #17 at a downward angle. If stroking Handle #10 now continues to build pressure, it indicates air has entered into the hydraulic system. See *“Bleeding and Filling the Hydraulic Fluid Bag”* instructions on page fourteen (14).
    - ii. A faulty Hydraulic Relief Valve #8 can relieve pressure earlier than expected. See *“Relief Valve Replacement”* on page eighteen (18).
12. While closely watching the 15,000 PSI Gauge #17B, stroke Handle #10. It should only require one (1) or two (2) full strokes before pressure begins to builds up. Do not stroke a third (3<sup>rd</sup>) time.
  - If the 15,000 PSI Gauge #17B indicator needle shows pressure building up, then drops back down, it indicates a leak in the system. Check the Hydraulic Pump Hose Assembly #17 and the Test Fitting connection for sealant leaks.
    - i. If the Hydraulic Pump Hose Assembly #17 is leaking sealant, repair it as required, and then retest the pump.

- ii. If the connection between the Giant Buttonhead Coupler #17G and the Test Fitting is leaking sealant, remove and reattach the Test Fitting and test again. If the leak continues, replace the Giant Buttonhead Fitting #17G, and then retest the pump.
    - iii. Check that the By-Pass Valve #7 is tight, it could also be damaged or obstructed, see “*By-pass Valve Repair and Replacement*” on page twenty-two (22).
    - iv. The Hydraulic Relief Valve #8 could be loose, weak, damaged or obstructed, see “*Relief Valve Replacement*” on page eighteen (18).
  - If the 15,000 PSI Gauge #17B reads zero (0) pressure and the indicator needle does not move, check the Hydraulic Pump Hose Assembly #17 and Test Fitting connection for sealant leaks.
    - i. Check if you can remove the Giant Buttonhead Coupler #17G from the Test Fitting. If the Test Fitting is difficult or impossible to remove it indicates there is pressure in the system and the 15,000 PSI Gauge #17B has failed. Immediately open By-Pass Valve #7 to relieve the pressure and replace the 15,000 PSI Gauge #17B. See “*Pressure Gauge Replacement*” on page twenty-four (24).
    - ii. If the Test Fitting removes easily, it indicates a leak in the system.
      - The By-Pass Valve #7 is not tight, or it is damaged or obstructed, see “*By-pass Valve Repair and Replacement*” on page twenty-two (22).
      - The Hydraulic Relief Valve #8 is loose, damaged or obstructed, see “*Relief Valve Replacement*” on page eighteen (18).
  - ***DANGER: never operate the Hydraulic Hand Pump with a failed 15,000 PSI Gauge #17B.***
13. Stroke the Handle #10 as required bringing the pressure on the 15,000 PSI Gauge #17B to approximately 5,000 PSI, then stop. Examine the Hydraulic Pump Hose Assembly #17 and Test Fitting connection for sealant leaks. Closely examine the Extra High-Pressure Hose #17E for bulges forming under the rubber casing.
- If the Hydraulic Pump Hose Assembly #17 is leaking sealant, repair it as required then retest the pump.
  - If the connection between the Giant Buttonhead Coupler #17G and the Test Fitting is leaking sealant, replace the Giant Buttonhead Coupler #17G then retest the pump.
  - If bulges begin forming on the outside of the Extra High-Pressure Hose #17E, immediately open By-Pass Valve #7 to relieve the pressure and replace the Extra High-Pressure Hose #17E then retest the pump.
14. Wait a few minutes then check that the reading on the 15,000 PSI Gauge #17B has not dropped.
- If the pressure on the 15,000 PSI Gauge #17B has dropped, it indicates a leak in the system. Return to step twelve (12).
15. Repeat steps thirteen (13) and fourteen (14) but this time bring the pressure on the 15,000 PSI Gauge #17B to approximately 8,000 PSI.
16. Continue stroking the Handle #10 and watch the 15,000 PSI Gauge #17B, pressure should build to approximately 11,000 PSI before relieving back to approximately 9,500 PSI.
- ***DANGER: never pressurize the pump more than 11,500 PSI.***
  - If the pressure gets over 11,000 PSI and does not relieve, it indicates a failed Hydraulic Relief Valve #8 and it must be replaced. Immediately open By-Pass Valve #7 to relieve the pressure. See “*Relief Valve Replacement*” on page eighteen (18).

- If the pressure never gets above 10,000 PSI, it indicates a weak Hydraulic Relief Valve #8 or a leak in the system. Return to step twelve (12).
17. Repeat step fourteen (14).
  18. Open By-Pass Valve #7 to relieve all pressure, and then retighten hand tight. Turn the Hydraulic Hand Pump vertically with the Hydraulic Pump Hose Assembly #17 pointing up. Let stand for 5 minutes. Repeat step thirteen (13).
    - If you cannot achieve a pressure of 5,000 PSI, it indicates there is air in the hydraulic system. See “*Bleeding and Filling the Hydraulic Fluid Bag*” on page fourteen (14).
  19. Open By-Pass Valve #7 to relieve all pressure. Remove the Test Fitting from the Giant Buttonhead Coupler #17G.

This completes the test. If you made it through all nineteen (19) steps without incident, your Hydraulic Hand Pump is in perfect working condition.

# Warranty

---

## Hydraulic Hand Pump Warranty

Sealweld Corporation warrants its products only against defects in materials and workmanship.

Sealweld Corporation's liability and customer's exclusive remedy under this warranty extends for a period of one (1) year from the date of Sealweld Corporation's shipment and is expressly limited to repayment of purchase price, repair or replacement, at Sealweld Corporation's option, during said period, upon proof satisfactory to Sealweld, and upon customers returning and prepaying all charges on such products to factory or warehouse designated by Sealweld. Warranty excludes normal wear items such as packing's, seals and filters. Also excluded is equipment subject to corrosion, contamination, negligence, accident, or units, which have been altered in any way.

This warranty is made expressly in lieu of all other warranties, express, implied or statutory, with respect to quality, merchantability, or fitness for a particular purpose.

---

## Disclaimer

The information contained within this manual is solely advisory.

You are responsible for understanding the information. You should not rely on this information as absolute. If you do act upon the suggestions contained in this manual, you are responsible for yourself and your actions.

Information contained herein is provided "as is" without warranty of any kind, either expressed or implied, including any warranty of merchantability or fitness for a particular purpose. The entire risk as to its quality, performance, or applicability is with you. If you rely on the information on these pages, you are responsible for ensuring by independent verification its accuracy or completeness.

Sealweld Corporation and its affiliates make no warranties, either expressed or implied, of merchantability or fitness for a particular purpose. This manual is published solely on an "as is" basis. Should the information in this manual prove to be false, misleading, or in contravention to law, statute, or regulation, you assume all risks. Sealweld Corporation and its affiliates will not be liable for direct, indirect (including, but not limited to any loss of business or anticipatory profits), incidental, or consequential damages resulting from your reliance on the information contained herein, even if the information was false, misleading, or in contravention to law, statute, or regulation, and even if Sealweld Corporation or any of its affiliates has been advised of the possibility of such.

No claims, promises or guarantees about the accuracy, completeness, or adequacy of the information contained in these pages are made. **In no event shall ANYONE be held liable for any loss of profit, special, incidental, consequential, or other similar claims.**

The illustrations, photos and images found in this manual are representations and are for illustration or 'for example' purposes only and do not necessarily represent the exact product or item being described. It is your responsibility prior to purchase to clarify the exact specifications of the product or item being purchased.

While every effort has been made to ensure its accuracy, this manual should be used as a general guide only and readers are encouraged to adapt content to the circumstances within their particular workplace. No responsibility is taken by the authors or publishers for any errors or omissions.



---

## Contact Information

### Sealweld Corporation – Canada

#106, 4116 – 64 Ave. S.E.

Calgary, Alberta

CANADA T2C 2B3

TOLL FREE 1-800-661-8465

PHONE 1-403-236-0043

FAX 1-403-236-5487

EMAIL [info@sealweld.com](mailto:info@sealweld.com)

URL <http://www.sealweld.com>



### Sealweld (USA), Inc.

6450 Skyview Drive

Houston, Texas

USA 77041

TOLL FREE 1-800-624-4301

PHONE 1-713-466-7373

FAX 1-713-466-7778

EMAIL [info@sealweld.com](mailto:info@sealweld.com)

URL <http://www.sealweld.com>



### ValvePro® Technical Support

TOLL FREE 1-800-661-8465

PHONE 1-403-236-0043

FAX 1-403-236-5487

EMAIL [support@valvepro.com](mailto:support@valvepro.com)

URL <http://www.valvepro.com>

