

2017

Fundamentals of

MECHANICAL ENGINEERING

For Diploma & Bachelor Engineers



Mr. SAID AL-JABRI

CONTENTS

CONTENTS	I
CHAPTER 1	1
1. ENGINEERING MATERIALS	1
1.1 CLASSIFICATION OF ENGINEERING MATERIALS	2
1.2 PROPERTIES OF MATERIALS	6
1.3 STRUCTURE OF MATERIALS	9
CHAPTER 2	10
2. FLUID POWER.....	10
2.1 FLUIDS MECHANICS AND FLUID PROPERTIES	11
2.2 PRESSURE AND ITS MEASUREMENT	12
2.3 LAMINAR AND TURBULENT FLOW	13
2.4 FLUID FLOW ANALYSIS	13
2.5 CONTINUITY AND BERNOULLI'S EQUATION	14
2.6 FLUID LOSSES IN PIPES	15
2.7 FLUID POWER SYSTEM	15
2.8 HYDRAULIC PUMPS & GAS COMPRESSORS	16
2.9 HYDRAULIC & PNEUMATIC ACTUATORS	18
2.10 HYDRAULIC & PNEUMATIC VALVES.....	19
2.11 SEALS	21
2.12 FILTERS	21
2.13 ACCUMULATORS & RESERVOIR	21
2.14 HYDRAULIC FLUIDS	23
2.15 TURBINES	23
2.16 TUBE AND PIPE REQUIREMENTS	24
CHAPTER 3	27
3. HEAT TRANSFER	27
3.1 CONCEPT OF HEAT	28
3.2 HEAT TRANSFER	31
CHAPTER 4	33
4. MECHANICS OF MACHINE.....	33
4.1 NEWTON'S LAW – KINEMATICS - KINETICS	34
4.2 CONCEPTS OF MECHANISMS	36
4.3 COMPUTER SIMULATION OF MECHANISMS	38
4.4 BALANCING OF ROTATING AND RECIPROCATING MASSES	38
4.5 CAMS AND FOLLOWERS	38
4.6 GEARS DRIVES	40

4.7 BELT DRIVES	42
4.8 WIRE ROPES	44
4.9 BREAKS	45
4.10 CLUTCHES	46
CHAPTER 5	48
5. THERMODYNAMICS	45
5.1 THERMODYNAMICS 1	49
5.2 THERMODYNAMICS 2	50
CHAPTER 6	70
6. PHYSICS	70
6.1 MAGNETISM	71
6.2 WAVES	73
6.3 REFLECTION AND REFRACTION OF LIGHT	75
6.4 AC CIRCUITS	77
6.5 KINETIC THEORY OF GASES	80
6.6 MODERN PHYSICS	82
CHAPTER 7	84
7. CHEMISTRY	84
7.1 CHEMICAL FORMULAE AND EQUATIONS	85
CHAPTER 8	94
8. MATHEMATICS	94
8.1 FORMULAS	95

CHAPTER 1

CHAPTER 1

Engineering

Materials

1.1 Classification of Engineering Materials:

1. Metals
2. Polymers
3. Ceramics
4. Composites
5. Semiconductors

❖ **Properties of metals:**

1. They have shiny surface
2. They are good conductor of heat and electricity
3. They are strong material
4. They are ductile- they can easily made into wire
5. They are malleable- they can easily made into different sheet
6. They are formable- they can easily made into different shapes
7. They have high melting points
8. They are heavy

❖ **Metals:** Types of metals are **Pure metals & alloys**

1. Pure metals:

- Metals in clear form or unmixed form.
- They are better conductor of electricity and heat than alloys.
- They are more ductile, malleable and formable than alloys.
- They are soft than alloys.
- Examples of pure metals are **Copper, Aluminum, Tin and Tungsten.**
 - a) **Copper** is used to make automobile radiator sheets, bottoms of cooking, pipes of heat exchangers, electrical wire cable and motor winding. Because it is good thermal conductivity, good electrical conductivity, ductile, malleable, low cost, more availability and easy for manufacturing.
 - b) **Aluminum** is used to make soft drink cans, windows frame, food storage foils. Because it is corrosion resistance, malleable, low cost, more availability and easy for manufacturing.
 - c) **Tin** is used to cover the surface of materials, because it is corrosion resistance.
 - d) **Tungsten** is used for filament in bulbs, because of its high melting point, corrosion resistance.

2. Alloys:

- Alloys are mixture of two or more metals.
- They are stronger and harder than pure metals.
- Examples of alloys are **Steel, Stainless Steel, High Speed steel (HSS), Brass, Cast Iron, Duralumin and Bell metal.**

1) **Steel** is made by mixing Iron and Carbon. **Types of steel:**

i. Low carbon steels

- If the percentage of carbon in steels are between 0.05-0.15%
- They are used for structure bars, automobiles bodies, and furniture.
- They have good strength, ductile, malleable, formable and easy for welding process.

ii. Mid steels

- If the percentage of carbon in steels are between 0.16-0.29%
- Used and properties same to Low carbon steel.

iii. Medium carbon steels

- If the percentage of carbon in steels are between 0.3-0.59%
- They are used to make Shaft, Bolts and Nuts. Because they are more strength compared to low carbon and mid steel.

iv. High carbon steel

- If the percentage of carbon in steels are between 0.6-0.99%
- They are used to make springs and ropes. Because they have more strength compared with low carbon steels, mild steel and high carbon steels.

v. Ultra-high carbon steels

- If the percentage of carbon in steels are between 1-2%
- They are used to make automobiles axles, workshop punches, workshop scribes, workshop dividers. Because they are very strong and hard compared to all other carbon steels.

2) **Stainless steel** is made by mixing Iron, Carbon, Chromium and Manganese

- It is used to make Vernier caliper, workshop ruler, bearing of machines, spoons, knives, plates, cups, surgical equipment.
- They are good strength, corrosion resistance, shiny surface, ductile, malleable, and formable.

3) **High Speed steel (HSS)** is an alloy of Iron, Carbon, tungsten, Chromium and vanadium.

- It is used to make cutting tools of various machines and workshop files.
- It has high hardness, high strength, high toughness, easy for re-sharpening and low cost.

4) **Brass** is made by mixing Copper and Zinc.

- It is used to make heat exchanger pipes and ship parts.
- It is stronger than Copper, good conductor of heat, malleable, low cost and corrosion resistance.

5) **Cast Iron** is made by mixing Iron, more than 2% of Carbon, silicon and Manganese.

- It is used to make machine tool bases.
- It is easy for casting, easy for cutting, medium hardness, absorb vibration and low cost.

6) **Duralumin** is an alloy of Aluminum, Copper, Magnesium and Manganese.

- It is used for making aircraft body, light truck wheels, light rivets.
- Because it has high strength, light weight, easy for shaping.

7) **Bell metal** is an alloy of Bronze, Copper and tin.

- It is used for making of Cannons, because it is easy for casting, good strength, toughness and hardness and easy for machining.

❖ **Polymers (Plastics):** They are compounds of carbon molecules joined together in long chains.

a) Properties of polymers:

1. They are insulator of heat and electricity
2. They have moderate strength
3. They are corrosion resistance
4. They are light in weight
5. They are they are ductile and malleable
6. They have low melting point

b) Types of polymers:

1. Thermoplastics
2. Thermosetting plastic
3. Elastomers

i. Thermoplastics

- Poly-ethylene (PE), Poly-Vinyl-Chloride (PVC) and Nylon are the examples of thermoplastics.
- They are used for making of bags(PE), water pipes(PVC), electric cable insulators(PE), bottles(PE) and low strength gear for toys(Nylon)
- Because they are soft, flexible, easy for manufacturing, light weight, they can be recycled and low cost.

ii. Thermosetting plastic

- Bakelite is an example for thermosetting plastic.
- It is used for making of TV covers, phone covers, handles of cookers and knobs
- Because it has more strength and hardness compared to thermoplastics.

iii. Elastomers

- These plastics are highly elastic in nature.
- Rubber is an example of elastomer; it is used for making of automobile tires.
- Because it is highly elastic and absorbs vibrations.

❖ **Ceramics:** are metallic and non-metallic oxides, carbides or nitrides.

a) Examples of Ceramics:

1. Aluminum Oxide (Alumina)
2. Silicon Nitride
3. Tungsten Carbide
4. Glass
5. Cement
6. and Sand

i. **Alumina, Silicon Nitride** are used for making of grinding machine wheels and grinding machine belt. Because they are very hard, heat resistant and can cut easily other engineering materials.

ii. **Tungsten Carbide** is used for making of cutting tools of machines like lathe, milling machine etc. Because it is very hard, heat resistant and can cut easily other engineering materials.

b) Properties of Ceramics:

1. They are very hard compared to other engineering materials.
2. They are brittle materials.
3. They are heat resistant materials (refractory materials).
4. They have high melting point.
5. They are corrosion resistant.
6. They are insulators of heat and electricity.

❖ **Composite Materials:** are made by mixing metal and non-metal or by mixing two different non-metals.

a) Different phases of composite materials:

1. **Major phase** called **Matrix**
2. And **Minor phase** called **Reinforcement**.

b) Examples of composite materials:

1. **FBR** (Fiber reinforced Plastic)
2. **RCC** (Reinforced Concrete Cement)
3. **C/C composite material** (Carbon Fiber Reinforced Carbon).

i. **FBR (Fiber reinforced Plastic)** is used for making safety helmets, sports car parts, wind turbines and light weight boats.

ii. **RCC (Reinforced Concrete Cement)** is made by mixing Steel and Concrete. It is used for construction of buildings and structures.

iii. **C/C composite material (Carbon Fiber Reinforced Carbon)** is made by mixing graphite and carbon fiber. It is used for brake discs of formula one car. Because it is hard and have good frictional properties.

❖ **Semiconductors:** They are materials with partial electrical conductivity. They are used for making of Electronics Boards, Diodes, Capacitors and transformers.

a) Examples of semiconductors

1. Silicon
2. Germanium

b) Properties of semiconductors:

1. they are partial conductors of electricity and heat
2. they are brittle
3. they have low strength

1.2 Properties of Materials

2. Mechanical Properties
3. Electrical Properties
4. Chemical Properties
5. Thermal Properties
6. Physical Properties

❖ **Mechanical Properties** Behavior of a material under action of force.

1. Strength
2. Elastic limit
3. Modulus of elasticity
4. Ductility / Brittleness
5. Toughness
6. Hardness

a) **Stress- Strain:**

i. **Stress:**

- It is the ratio of force and area.
- $\text{Stress} = \text{Force}/\text{Area}$, SI Unit N/m^2 or Pa

ii. **Strain:**

- It is the ratio of change in length (Extension) to the original length.
- $\text{Strain} = L_f - L_o / L_o$, No unit
- **Percentage Elongation** = Strain * 100

iii. **Hooke's Law:** stress is directly proportional to strain.

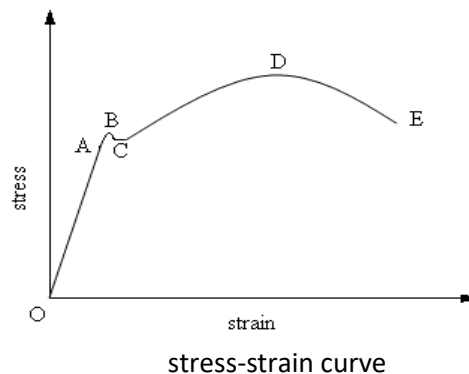

- Elastic Limit:** the limit that when force is removed, material comes back to its original shape.
- Upper yield point:** the point at which yielding observed at higher stress value.
- Lower yield point:** the point at which yielding observed at lowest stress value.
- Ultimate tensile strength:** the maximum stress that material can withstand before it breaks.
- Breaking or Fracture point:** the point at which material breaks.

b) **Modulus of elasticity (Young's Modulus):**

- It is the ratio of stress and strain.
- Modulus of elasticity (E) = Stress/Strain
- If a material has more modulus of elasticity, it has more stiffness.

c) **Ductility:**

- When a material deforms more before fracture.
- It is very important property for making of wire.
- Pure metals like Gold, Silver, Copper and Aluminum are examples of ductile materials.

d) **Brittleness:**

- When a material deforms less before fracture.
- Brittle materials fail suddenly without warning.
- Ceramics like Glass, Alumina and Silica are examples of brittle materials.

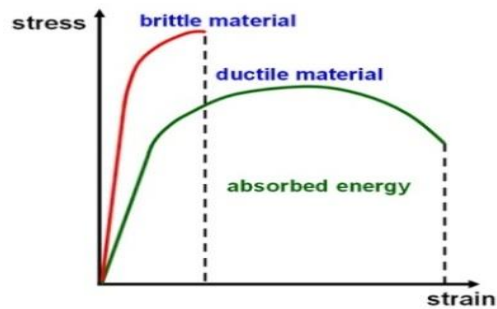

Stress-Strain Curves for Ductile and Brittle Materials

e) **Toughness:**

- Ability of a material to absorb energy before fracture.
- Ductile materials have more toughness than brittle materials.
- Toughness is measured in Joule.
- Toughness is measured using Charpy and Izod Testing Machine.

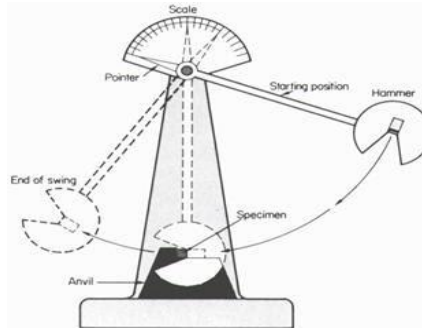

Charpy and Izod Testing Machine

f) **Hardness:**

- It is the resistance to indentation.
- It is measured by force applied divided surface area of indentation (N/m^2)
- Machines used for testing hardness are Brinell hardness tester, Vickers hardness Tester and Rockwell Hardness Tester.
- Hardest natural material is Diamond.

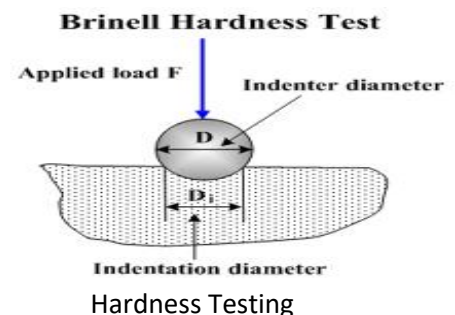

❖ **Electrical Properties:** Behavior of a material under action of force. It is useful for making electrical products like wire, Motor etc.

1. Electrical Conductivity
2. Electrical Resistivity
3. Dielectric Strength

a) **Electrical Conductivity:**

- It is ability of a material to pass electrical current.
- **Conductivity:** Silver > Copper > Aluminum

b) **Electrical Resistivity:**

- It is ability of a material to resist the flow of electrical current.
- High electrical resistivity materials are used as Insulator.
- **Resistivity: Polymers = Ceramics > Metals**

c) **Dielectric Strength:**

- It is ability of a material to withstand high voltage without breaking.
- **Dielectric Strength:** Polymers > Ceramics > Metals

❖ **Chemical Properties:** Behavior of a material under **Chemical Reactions.**

1. Important Chemical Properties is **Corrosion.**
2. Corrosion is Oxidation of materials by react with Oxygen.
3. Methods used to stop corrosion are Painting, Cleaning, electro-plating, galvanization, cathodic protection and chloride extraction.
4. **Corrosion Resistance:** Ceramics = Polymers > Metals

❖ **Thermal Properties:** Behavior of a material under the action of **heat.**

1. Co-efficient of linear expansion
2. Specific heat

a) **Co-efficient of linear expansion:**

- Materials expand when temperature increases.
- High Co-efficient means, material expands more with small temperature.
- **Co-efficient of linear expansion:** Polymers > Metals > Ceramics

b) **Specific heat:**

- The amount of heat energy required to rise the temperature of 1 Kg of substance by 1° .
- Specific heat (C) = $\frac{\text{Heat Energy}}{\text{Mass} \times \text{Change in Temperature}}$, SI units- J/Kg.K
- High specific heat means, more heat energy required to rise its temperature.
- **Specific heat:** Polymers = Ceramics > Metals

❖ **Physical Properties:** Behavior of a material under changing the composition.

1. Density
2. Specific Strength

a) **Density:**

- It is the ratio of Mass and Volume.
- $P = m/V$, SI unit Kg/m^3
- High density materials are heavier compared to low density materials.

b) **Specific Strength:**

- It is the ratio of strength and density. SI unit $\text{Pa}/\text{Kg}.\text{m}^{-3}$

1.3 Structure of Materials

- Structure means arrangement. Structure of materials is arrangement of atoms in materials.

❖ **Classification of engineering materials based on structure:**

1. **Crystalline Materials:** If the atoms arrangement in material is regular order.
 - Examples of Crystalline Materials are Pure Metals, Alloys, some Ceramics and Semiconductors.
2. **Partially Crystalline Materials:** If the atoms arrangement in material is regular order and irregular in other areas. Example: Polymers
3. **Non-Crystalline (Amorphous) Materials:** If the atoms arrangement in material is irregular order.
 - Ex: Wood, Composite materials and some Ceramics.

❖ **Different between the properties of Amorphous and Crystalline Materials:**

Amorphous Materials	Crystalline Materials
<ol style="list-style-type: none">1. They have low strength2. They are light in weight3. They are brittle4. They are insulator of heat and electricity	<ol style="list-style-type: none">1. They have high strength2. They are heavy3. They are ductile4. They are conductor of heat and electricity

CHAPTER 2

Fluid Power

2.1 Fluids Mechanics and Fluid Properties

- **Fluid mechanics** is the branch of engineering which deals with behavior of fluid at rest & motion
- There are three states of matter: **Solid, Liquid and Gas**. Liquid and gas are both fluids.

❖ Difference between Liquids & Gasses

Liquids	Gasses
<ul style="list-style-type: none"> • It is difficult to compress & incompressible. • It has fixed volume. 	<ul style="list-style-type: none"> • It is easily to compress • It has no fixed volume; its volume changes with pressure.

❖ Properties of Fluids:

1. Density:

- It is the mass per unit volume.
- $\rho = \frac{m}{V} \text{ kg/m}^3$
- $\rho_{water} = 1000 \text{ g/m}^3$, $\rho_{air} = 1.23 \text{ kg/m}^3$, $\rho_{mercury} = 13546 \text{ kg/m}^3$

2. Specific Weight or Weight density:

- It is the weight per unit volume.
- $\omega = \frac{W}{V} \text{ N/m}^3$, $w = mg \text{ N}$

3. Specific Gravity or Relative Density:

- It is the ratio of density of substance to standard density.
- For solids and liquids the standard density is the density of water.
- $\sigma = \frac{\rho_{substance}}{\rho_{water}} \text{ kg/m}^3$, $\sigma_{water}=1$

4. Viscosity:

- It is the resistance of fluid flow.
- Fluid with high viscosity flows more slowly than fluid with a low viscosity.
- **Newton's Law of Viscosity:** shear stress is directly proportional to the rate of change of velocity.

❖ Classification of fluids:

1. Ideal fluid:

- Fluids which have no viscosity and surface tension.
- They are incompressible and not exist in nature.
- Fluids with low viscosity like water and air maybe classify as ideal fluid.

2. Real fluid:

- Fluids which have viscosity & surface tension.
- They are compressible and exist in nature.

3. Newtonian fluid:

- Fluids which follow Newton's law of viscosity like water, air, petrol.

4. Non-Newtonian fluid:

- Fluids which don't follow Newton's law of viscosity like printer ink.

2.2 Pressure and its measurement

- ❖ **Pressure:** It is the force per unit area. $p = \frac{F}{A} \text{ N/m}^2$ or Pa or SI unit bar (1 bar= 10^5 N/m^2)
- ❖ **Pascal's Law for Pressure:** Pressure at any point in a fluid is the same in all directions.
- ❖ **Absolute pressure and Gauge pressure:** $p_{\text{absolute}} = P_{\text{gauge}} + P_{\text{atmospheric}}$

The pressure at the surface of fluids is the atmospheric pressure ($P_{\text{atmospheric}}$), $P_{\text{gauge}} = \rho gh$

❖ Pressure measurement by Manometer:

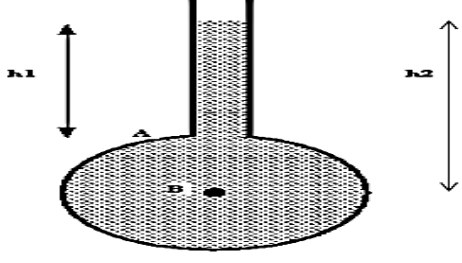
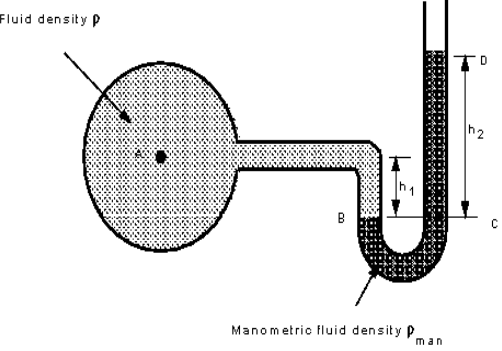
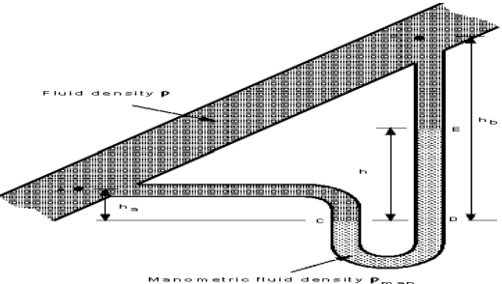
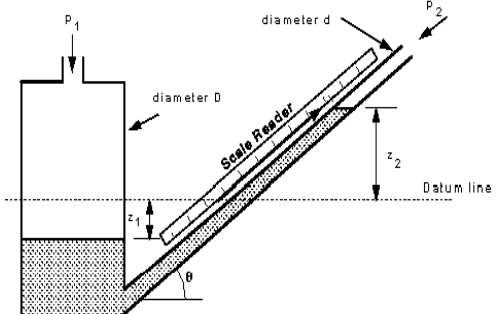
<p style="text-align: center;">The Simple (Piezometer) Tube Manometer</p>	<p style="text-align: center;">$p_A = \rho gh_1, p_B = \rho gh_2$</p> <ul style="list-style-type: none"> • The tube is open to the atmosphere; so the pressure measured is relative to atmosphere. • This method can only used for liquids not for gases and only when the liquid height is easy to measure. 	
<p style="text-align: center;">The "U" Tube Manometer</p>	<p>$P_B = P_C$ For the left hand arm: $P_B = P_A + \rho gh_1$ For the right hand arm: $P_C = P_{\text{Atmosphere}} + \rho_{\text{man}} gh_2$ As we measure P_{gauge} subtract P_{atm} $P_B = P_C$ $P_A = \rho_{\text{man}} gh_2 - \rho gh_1$ This method can use for both liquids and gases.</p>	
<p style="text-align: center;">Measurement of Pressure Difference Using a "U" Tube Manometer</p>	<p>$P_C = P_D$ $P_C = P_A + \rho gh_a$ $P_D = P_B + \rho g(h_b - h) + \rho_{\text{man}} gh$ $P_A + \rho gh_a = P_B + \rho g(h_b - h) + \rho_{\text{man}} gh$ The pressure difference: $P_A - P_B = \rho g(h_b - h_a) + (\rho_{\text{man}} - \rho) gh$</p>	
<p style="text-align: center;">Tilted Manometer</p>	<p>The pressure difference: $P_1 - P_2 = \rho gz_2$ $= \rho g x \sin \theta$</p>	

- **Advantages of Manometers:**

1. They are very simple
2. No calibration required

- **Disadvantages of Manometers:**

1. Slow response
2. Difficult to measure small variation in pressure
3. The density changes (decreased) when temperature changes (increased)
4. For "U" Tube Manometer, two measurements must be taken to get the "h" value

2.3 Laminar and Turbulent Flow

❖ **Laminar flow:** The fluid particles move regular and order in straight lines.

- $Re < 2000$
- It is stable flow
- Low viscosity
- Dye doesn't mix with water
- Fluid particles move in straight lines

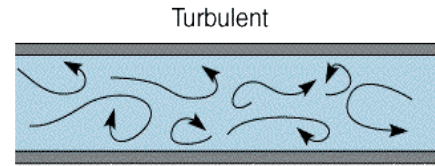

❖ **Turbulent flow:** The fluid particles move irregular in jagged lines

- $Re > 4000$
- It is unstable flow
- High velocity
- Dye completely mixes with water
- Fluid particles move irregular in jagged lines
- Most common type of flow

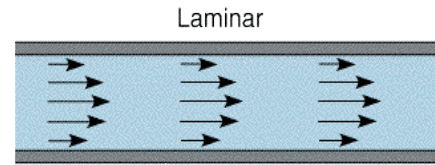

❖ **Transitional flow:** The fluid particles move in wave lines.

- $2000 > Re < 4000$
- Medium velocity
- Dye partly mixes with water
- Fluid particles move in wave lines

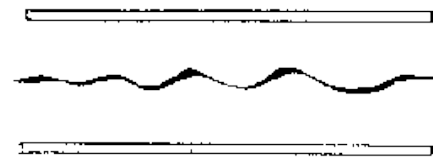

Transitional

❖ **The Reynolds number:** $Re = \frac{ud}{\mu} = \frac{\text{inertial forces}}{\text{viscous forces}}$, u =velocity, d =diameter

2.4 Fluid Flow Analysis

❖ **Uniform Flow & Steady Flow**

- **Uniform flow:** If the flow velocity is the same at every point in the fluid.
- **Non-uniform Flow:** If the flow velocity isn't the same at every point in the fluid.
- **Steady Flow:** The velocity & pressure at a point don't change with time.
- **Unsteady Flow:** The velocity & pressure at a point change with time.

❖ **Compressible & Incompressible Flow**

- **Compressible flow:** The density of fluid changes from point to point. Example: flow of gases.
- **Incompressible flow:** The density of fluid is constant from point to point. Example: flow of liquid. All fluids are compressible (their density will change) when pressure changes.

❖ **Dimensional Flow**

- **One dimensional flow:** The fluid flows in one direction only. Example: flow in pipe.
- **Two dimensional flow:** The fluid flows in two directions (x & y). Example: flow in parallel plates.
- **Three dimensional flow:** The fluid flows in three directions. Example: flow in a convergent or divergent pipe.

❖ **Mass flow rate:** It is the mass per unit time. Mass flow rate = $\frac{\text{mass}}{\text{time}}$ kg/s

❖ **Volume flow rate (Discharge):** It is the volume per unit time. $Q = \frac{\text{volume of fluid}}{\text{time}} = Au \text{ m}^3/s$

A = area, u = velocity

2.5 Continuity and Bernoulli's Equation

- ❖ **Continuity Equation:** It is a statement of mass conservation (matter cannot be created or destroyed)
Mass entering per unit time = Mass leaving per unit time

$$A_1 u_1 = A_2 u_2 = Q$$

- **Applications of Continuity Equation:**

1. Pipe with a contraction:

$$Q_1 = Q_2$$

$$A_1 u_1 = A_2 u_2$$

$$u_2 = \left[\frac{d_1}{d_2} \right]^2 u_1$$

$$A = \frac{\pi d^2}{4}$$

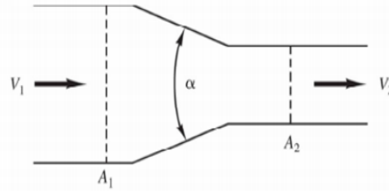

2. Pipe with expands or diverges:

$$Q_1 = Q_2$$

$$A_1 u_1 = A_2 u_2$$

$$u_1 = \left[\frac{d_2}{d_1} \right]^2 u_2$$

$$A = \frac{\pi d^2}{4}$$

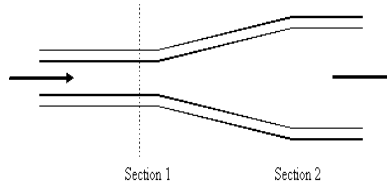

3. Pipes coming from a junction:

$$Q_1 = Q_2 + Q_3$$

$$A_1 u_1 = A_2 u_2 + A_3 u_3$$

$$A = \frac{\pi d^2}{4}$$

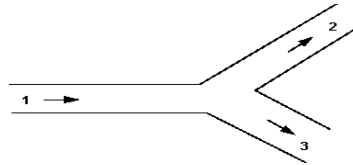

4. Flow from a reservoir:

$$u_1 = 0$$

$$u_2 = \sqrt{2g(z_1 - z_2)}$$

$$A = \frac{\pi d^2}{4}$$

$$Q = Au$$

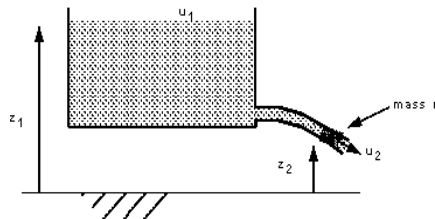

- ❖ **Bernoulli's Equation:** The sum of pressure head, velocity head and potential head is constant.

$$\frac{p_1}{\rho g} + \frac{u_1^2}{2g} + z_1 = \frac{p_2}{\rho g} + \frac{u_2^2}{2g} + z_2 \qquad \frac{p}{\rho g} + \frac{u^2}{2g} + z = H$$

$$\frac{p}{\rho g} = \text{Pressure head}, \frac{u^2}{2g} = \text{Velocity head}, z = \text{Potential head}, H = \text{Total head}$$

- **Applications of Bernoulli's Equation:**

1. Venturi meter: It is a device used for measuring discharge in a pipe.

$$\frac{p_1}{\rho g} + \frac{u_1^2}{2g} + z_1 = \frac{p_2}{\rho g} + \frac{u_2^2}{2g} + z_2$$

$$z_1 = z_2$$

$$Q = A_1 u_1 = A_2 u_2$$

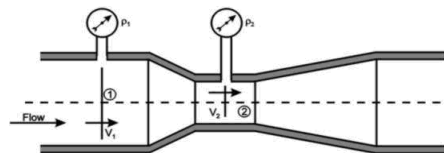

2. Flow through Orifice: The fluid flow through the sharp edged orifice.

$$(u_1 = 0), (p_1 = 0), (p_2 = 0), (z_1 = h), (z_2 = 0)$$

$$u_2 = \sqrt{2gh}$$

$$Q = Au$$

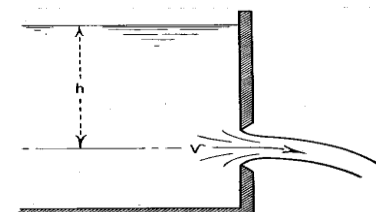

3. Stagnation Pressure: the fluid goes to the head of blunt body and stops, because at this point (stagnation point) the velocity is zero. Pressure at stagnation point called Stagnation Pressure

$$(z_1 = z_2), \text{ at point 2 } (u_2 = 0)$$

$$\frac{p_1}{\rho g} + \frac{u_1^2}{2g} + z_1 = \frac{p_2}{\rho g} + \frac{u_2^2}{2g} + z_2$$

$$p_2 = p_1 + \frac{1}{2} \rho u_1^2$$

Stagnation Pressure = Static Pressure + Dynamic Pressure

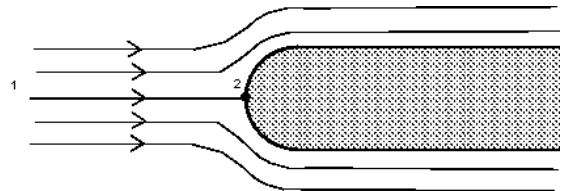

4. Pilot Tube: Two piezometers, one as normal and one as pilot tube within the pipe used to measure velocity of flow.

$$(z_1 = z_2), (u_2 = 0)$$

$$\frac{p_1}{\rho g} + \frac{u_1^2}{2g} + z_1 = \frac{p_2}{\rho g} + \frac{u_2^2}{2g} + z_2$$

$$p_2 = p_1 + \frac{1}{2} \rho u_1^2$$

$$\rho g h_2 = \rho g h_1 + \frac{1}{2} \rho u_1^2$$

$$u_1 = \sqrt{2g(h_2 - h_1)}$$

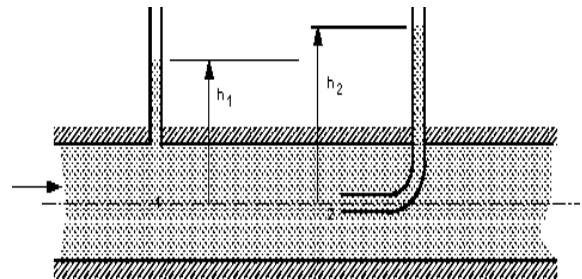

2.6 Fluid Losses in Pipes

- ❖ **Losses due to friction:** These losses depend on:
 1. Roughness of the inside surface of the pipe
 2. Reynolds number
- ❖ **Losses due to pipe fittings:** These include:
 1. Bends
 2. Valves
 3. Sudden or Gradual Enlargement
 4. Sudden or Gradual contraction
 5. Exit loss
 6. Entry loss (similar to Sudden contraction)

2.7 Fluid Power System

- ❖ **Fluid Power:** It is deals with the generation, control and transmission of power, using Pressurized fluids
It is used to push, pull, regulate or drive of all the machines of industry.
- ❖ **Difference between Hydraulics and Pneumatics:**

Hydraulics	Pneumatics
<ul style="list-style-type: none"> • The fluid is a liquid such as water, diesel and petroleum. • It is used for high pressure applications(4000 kN loads) 	<ul style="list-style-type: none"> • The fluid is a gas such as air. • It is used for low pressure applications (30 kN loads)

- ❖ **Advantages of fluid power:**
 1. Less loss of power, so more efficiency
 2. Large force with great accuracy
 3. Linear or rotary force can be multiplied the output power
- ❖ **Disadvantages of fluid power:**
 1. Flammable hydraulic fluid may create fire hazards
 2. Pneumatic system, such as compressor may create explosive

❖ **Fluid power applications:**

1. **Manufacturing industry:** Hydraulic presses, pneumatic hand tools, etc.
2. **Automobile industry:** Hydraulic brakes, Power steering, etc.
3. **Material handling field:** Hydraulic lift truck, Hydraulic jacks, Hydraulic elevators, etc.
4. **Construction field:** Earth moving equipment.

❖ **Basic components of fluid power system:**

- **Hydraulic pump or air compressor:** It converts mechanical power to fluid power.
- **Actuator:** It converts fluid power to linear or rotary mechanical power.
- **Valves:** They control direction, pressure and rate of flow.
- **Filters:** They remove particles pollutions from fluid.
- **Tubes, Fittings, Coupling, etc:** They link the fluid between components.
- **Sealing devices:** They help to contain the fluid.
- **Accumulators and reservoirs:** They store the fluid.
- **Instruments such as pressure gauge, flow mater:** They are used to monitor the performance of fluid power system.

❖ **Principle of Hydraulics or (Pascal's Law):** When given load over a smaller area, the force produced on a larger area is higher.

$$p_1 = p_2 \rightarrow \frac{F_1}{A_1} = \frac{F_2}{A_2} \rightarrow F_2 = \frac{F_1 A_2}{A_1}$$



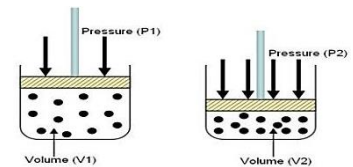

❖ **Principle of Pneumatics or (Boyle's Law):** The pressure of gas is inversely proportional to its volume, when the temperature is constant.

$$p \propto \frac{1}{V} \rightarrow p_1 V_1 = p_2 V_2$$



2.8 Hydraulic Pumps & Gas Compressors

- **Hydraulic Pumps:** It is a mechanical device that increases the pressure of a liquid by reducing its volume. It is the heart of hydraulic system. Symbol 
- **Gas Compressors:** It is a mechanical device that increases the pressure of a gas by reducing its volume. Symbol 

❖ **Classification of (Pumps & Compressors):**

1. **Non Positive Displacement (Pumps or Compressors) or (Centrifugal Pumps or Compressors):**

- Use impeller to force the fluid to the volute casing which convert kinetic energy into pressure energy.
- They are used for low pressure and high volume applications (up to 40 bar).
- They are used for fluid transportation and circulation etc.

2. **Positive displacement (Pumps & Compressors):**

- They apply pressure directly to the fluid by reciprocating piston or by rotating member.
- It is used for very high pressure fluids (up to 700 bar).
- They are used for variable viscosity applications.

❖ **Classification of Positive displacement (Pumps & Compressors):**

1. **Reciprocating (Pumps & Compressors):** In this pump or compressor, the chamber is a stationary cylinder that contains piston or plunger. **They are classified as:**
 - i. Piston Pumps,
 - ii. Plunger Pumps,
 - iii. Diaphragm Pumps
2. **Rotary (Pumps & Compressors):** In this pump or compressor, the chamber moves from inlet to discharge and back to the inlet. **They are classified as:**
 - i. Gear Pumps,
 - ii. Lobe Pumps,
 - iii. Screw Pumps,
 - iv. Vane Pumps

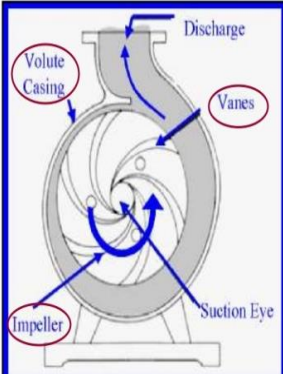
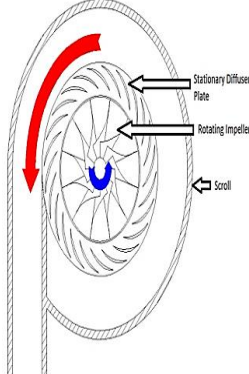
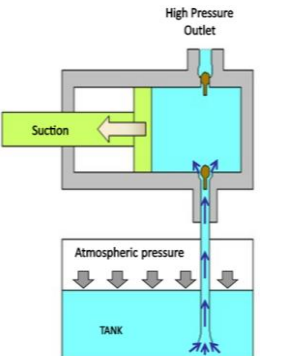
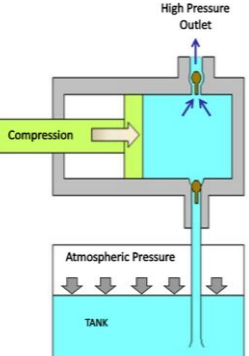
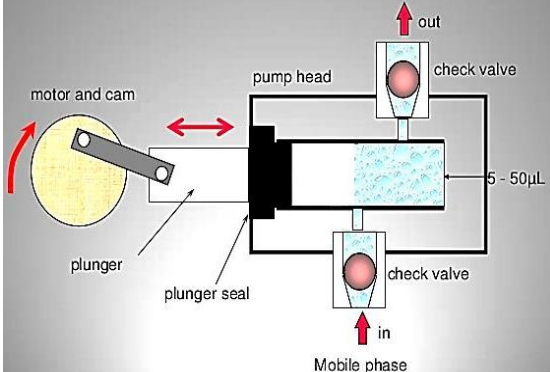
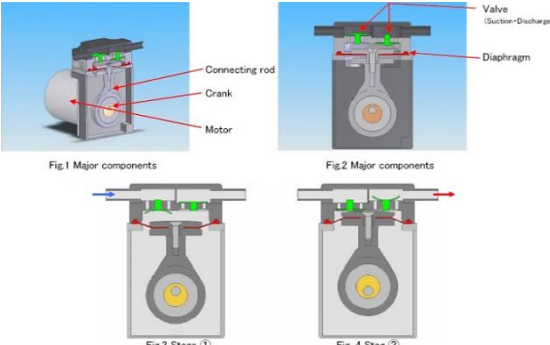
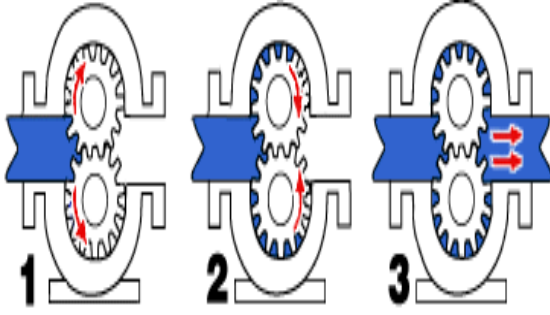
Types	How do they work	Simple pictures	
Centrifugal Pumps	<ul style="list-style-type: none"> Liquid forced into impeller from suction eye. Vanes produce kinetic energy to liquid, liquid rotates and leaves impeller. Volute casing converts kinetic energy into pressure energy. 		
Centrifugal Compressor	<ul style="list-style-type: none"> Liquid forced into impeller from suction eye. Vanes produce kinetic energy to liquid, liquid rotates and leaves impeller. Diffuser decreases or converts kinetic energy into pressure energy of gas. 		
Piston Pumps & Compressor	<ul style="list-style-type: none"> When the piston moves to the left, it creates vacuum inside the cylinder. Because pressure difference between atmosphere pressure and cylinder pressure, the liquid moves from tank to cylinder by open inlet valve and close outlet valve. When the piston stops, both valves are closed and when the piston is starting moves to the right, the pressure increased and discharge valve open. 		
Plunger Pumps & Compressor	<ul style="list-style-type: none"> The plunger moves back and forth by motor driving. Because of pressure difference between atmosphere pressure and cylinder pressure, the liquid moves from tank to cylinder by open inlet valve and close outlet valve. When both valves are closed, the plunger increases the pressure of liquid and then discharge valve open and high pressure liquid goes out. 		
Diaphragm Pumps & Compressor	<ul style="list-style-type: none"> The diaphragm moves back and forth by motor driving. Because of pressure difference between atmosphere pressure and cylinder pressure, the liquid moves from tank to cylinder by open inlet valve and close outlet valve. When both valves are closed, the diaphragm increases the pressure of liquid and then discharge valve open and high pressure liquid goes out. 		
Gear Pump & Compressor	<ul style="list-style-type: none"> They have two gears, one is connected to the driver shaft and other is driven as its meshes with the driver gear. As the gears come out of mesh, they create expanding volume and low pressure on the inlet side of the pump. Liquid flows into the pump because pressure difference. Liquid travels around between teeth and casing; they create compression volume and high pressure. Finally, the gears go into mesh and forces liquid through discharge under pressure. 		

2.9 Hydraulic & Pneumatic Actuators

- **Hydraulic Actuators:** They convert hydraulic energy of pump into mechanical power.
- **Pneumatic Actuator:** They convert pneumatic energy of compressor into mechanical power.

❖ Classification of Actuators:

1. Linear Actuators:

- They convert fluid energy into linear force and linear motion.
- They are cylinder-piston system which moves back and forth during the operation cycle.
- **Types of linear Actuators:**
 - i. Single acting type
 - ii. Double acting type

2. Semi-Rotary Actuator:

- They convert fluid energy into limited rotation or oscillatory motion.
- They are known as limited rotation motor.
- **Types of Semi-Rotary Actuators:**
 - i. Vane type
 - ii. Piston type

3. Rotary Actuators:

- They convert fluid energy into rotational motion.
- They are known as rotation motor.
- **Types of Rotary Actuators:**
 - i. Gear motor
 - ii. Vane motor
 - iii. Piston motor

Types of Rotary Actuators	How do they work	Simple pictures	Symbols
Single acting type	<ul style="list-style-type: none"> • It has only one port at one end of the cylinder. • The fluid pressure enters from pressure port and pushes the piston forward. • When the fluid pressure is cut off, the piston returns to its position by a spring. 		
Double acting type	<ul style="list-style-type: none"> • It has two ports at both ends of the cylinder. • The fluid pressure enters from port 1 and pushes the piston forward. • The fluid pressure is cut off from port 1 and start flow from port 2 to return piston to its position. 		
Gear motor	<ul style="list-style-type: none"> • It is similar to gear pump & gear Compressor. • It is also similar to electric motors but is run on hydraulic or pneumatic power. • They have two gears, one is connected to the driver shaft and other is driven as its meshes with the driver gear. • Compressed fluid enters from inlet and rotates the gears and produced torque. 		

2.10 Hydraulic & Pneumatic Valves

- The pressurized fluid from Pump or Compressor is moved to the actuators using Valves.

❖ Valves are used to control:

1. Direction of flow
2. Pressure of flow
3. Quantity of flow
4. Stoppage of flow

❖ Classification of Valves:

1. Direction control valve (D.C. Valves):

- They are used to reverse the direction of actuator, and to start and stop piston movement.

- **Classification of D.C. Valves:**

- I) Based on construction:

- 1) Seat or Poppet valve
- 2) Spool valve or sliding valve
 - a) Rotary spool valve
 - b) Sliding spool valve

- II) Based on Number of ports:

- 1) Two way valve_(Check valves):
 - It has two ports, it is also called non-return valves
 - It is used to allow flow in only one direction.
 - Poppet & pilot operated are types of check valves.
- 2) Three way valve
- 3) Four way valve

- III) Based on number of ports & number of valve position:

- 1) Two way, two position valves (2/2 valves)
- 2) Three way, two position valves (3/2 valves)
- 3) Four way, two position valves (4/2 valves)
- 4) Four way, three position valves (4/3 valves)

- IV) Based on the type of power source used:

- 1) Shuttle valve

- V) Based on the mode of actuation of D.C. valves:

- 2) Manually operated D.C. valves
- 3) Mechanically operated D.C. valves
- 4) Solenoid operated D.C. valves
- 5) Pilot operated D.C. valves

2. Pressure control valve:

- They are used to reducing / increasing pressure, and providing maximum pressure thereby ensuring safety.

- **Classification of pressure control Valves:**

- I) Pressure relief valve:

- 1) Direct acting or simple pressure relief valve
- 2) Pilot operated or compound pressure relief valve

3. Flow control valve:

- They are used to control the speed of actuator by controlling the rate of fluid flow.

- **Classification of pressure control Valves:**

- I) Globe valve
- II) Needle valve

Type of Valve	How do they work	Simple pictures	Symbols
Seat or Poppet valve	<ul style="list-style-type: none"> It consists of poppet or ball, return spring and push button. When push button is depressed, ball is pushed out of its seat and fluid flow from port 1 to port 2 When push button is released, ball is returned to its seat by spring and stop flow. 		Flow path Flow shut off
Sliding spool valve	<ul style="list-style-type: none"> It consists of small piston like spool placed inside the valve body. The spool slides inside the valve body to open and close the ports. 		Valve Push button Lever Pedal Plunger Spring
Pilot operated check valve	<ul style="list-style-type: none"> It allows the reverse flow. When fluid flow in the normal direction, the fluid pressure pushed the poppet out of its seat and fluid flow from port A to port B. To allow the fluid flow in reverse direction, the pilot pressure pushes the pilot piston and the poppet down. 		
Poppet type check valve	<p>Position 1</p> <ul style="list-style-type: none"> When fluid flow in the normal direction, the fluid pressure pushed the poppet out of its seat and fluid flow from port in to port out. <p>Position 2</p> <ul style="list-style-type: none"> When flow stop, the poppet returns to its seat by spring and fluid can't pass in the reverse direction. 		Check valve or Non-return valve
The 2/2 D.C. valve	<p>Position 1</p> <ul style="list-style-type: none"> When push button is depressed, ball is pushed out of its seat and fluid flow from port P to port A. <p>Position 2</p> <ul style="list-style-type: none"> When push button is released, ball is returned to its seat by spring and stop flow. 		2/2 D.C. valve open 2/2 D.C. valve open
Shuttle valve	<ul style="list-style-type: none"> It is used when control more than one power source. When the pressure in the right inlet port is greater than the left port inlet, the shuttle piston closes the left port. When the pressure in the left inlet port is greater than the right inlet port, the shuttle piston closes the right port. 		2/2 D.C. valve open 4/2 D.C. valve
Needle valve	<ul style="list-style-type: none"> It has a Stem that adjusted manually to control flow rate. It has a smaller flow area and higher pressure than Globe valve. 		4/3 D.C. valve
Simple pressure relief valve	<ul style="list-style-type: none"> It is used to prevent rising in the pressure. When the pressure exceeds set limit, the fluid forced the spring to allow fluid to flow to the tank port. Otherwise the valve is closed. 		

2.11 Seals

❖ **Function of Seals:**

- a) Control of external and internal leakage of fluid.
- b) Control of fluid loss
- c) Maintenance of system pressure
- d) Prevent of pollution entering the system

❖ **Classification of Seals:**

1. **According to the method of sealing:** Positive sealing (prevents leakage) and non-positive sealing (allows small leakage for lubrication).
 2. **According to their location in a system:** Static seals (used when no movement occurs between parts) and dynamic seals (used when movement occurs between parts).
 3. **According to geometric shape of sealing:** U-cup ring, Hat ring, T-ring, Quad ring, O-ring, V-ring.
 4. **According to seal material:** Leather seals, Metal seals, Polymers, Elastomers and plastic seals, Nylon seals etc.
-

2.12 Filters

❖ **Function of Filters:**

- a) Remove particles pollutions from fluid.
- b) Increase life of system component and fluid.

❖ **Classification of Filters:**

1. **According to the distance:**
 - i. Surface Filter: It has less thickness and less capacity.
 - ii. Depth Filter: It has more thickness and more capacity.
2. **Full flow filter:** All fluid pass through the filter, whether need filtration or not.
3. **By-pass filter:** Part of fluid passes through the filter, only which need filtration.

❖ **FRL Unit:**

- The combination of Filter, Regulator and Lubricator.
 - The compressed fluid is first filtered and then pressure regulated and finally lubricated.
-

2.13 Accumulators & Reservoir

❖ **Accumulators:**

- It is a device which stores the potential energy of fluid.
- **Types of Accumulator:**
 1. Gravity or dead weight type
 2. Spring loaded type
 3. Gas loaded type
 - i. Non-Separator type
 - ii. Separator type
 - a) Piston type
 - b) Diaphragm type
 - c) Bag or Bladder type
- **Applications of accumulator:**
 1. Pressure compensation
 2. Leakage compensation
 3. Emergency source of power

Type of Accumulator	How do they work	Simple pictures
Dead weight type	<ul style="list-style-type: none"> It consists of cylinder housing a piston with packing inside to prevent leakage. The force of gravity of the dead weight is used to store potential energy. 	
Spring loaded type	<ul style="list-style-type: none"> It consists of cylinder housing a piston with spring. The force of compression spring is used to store potential energy. 	
Non-Separator gas loaded type	<ul style="list-style-type: none"> It consists of cylinder having one oil part at the bottom which contacts with a gas on the top. Storage of potential energy is due to compression of gas. The expansion of gas forces the oil out of the accumulator. 	
Separator piston type	<ul style="list-style-type: none"> It consists of spherical vessel which has fluid chamber at the top and separated with air chamber on the bottom by diaphragm. When the oil enters into accumulator, it pushes the diaphragm and compressed the air. This gas pressure is used as the potential energy to force the oil out when it is required. 	
Bag or Bladder type	<ul style="list-style-type: none"> It consists of bag or bladder placed inside the accumulator which has gas and oil which placed outside the bag. When the oil enters into accumulator, it pushes the bag and compressed the air inside the bag. This gas pressure is used as the potential energy to force the oil out when it is required. 	

❖ Reservoir:

- It is a device used to store the fluid.
- Functions of Reservoir:**
 - Oil storage:** It provides sufficient volume to store oil.
 - Heat dissipation from oil:** It provides large surface area to dissipate heated oil.
 - Thermal expiation of fluid:** It provides extra space to be ready for thermal expansion of fluid.
 - Separation of various contaminants:** It is used Gause baffles to separate contaminants from oil.
 - Controlling turbulent flow:** It is used Baffle plates to control turbulent flow.

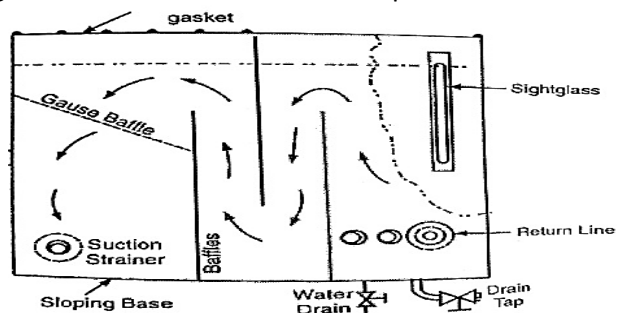

Feature of Reservoir

2.14 Hydraulic Fluids

- It is used to transmit and control energy in a system.
- Incompressible fluids like oils and water are used in hydraulic systems.

❖ **Function of Hydraulic fluids:**

- To transmit power
- To lubricate moving parts
- To seal gaps and cleaning parts
- To dissipate heat causing friction
- To prevent rust and corrosion

❖ **Types of hydraulic fluids:**

1. Mineral oils
2. Oil in water
3. Water in oil
4. Water glycol

❖ **Desirable properties of hydraulic fluids:**

1. **Specific gravity:** It is an important property for design of pump, reservoir, piping sizing and for calculation of pressure at pump inlet.
2. **Viscosity:** Should have low enough viscosity for lubricate surface and for easy flow ability. Also having enough viscosity for seal gaps and leakage.
3. **Coefficient of thermal expansion:** provision in the system design as pipe design, reservoir design etc.
4. **Flammability:** Must be non- flammable and should have high flash point and fire point.
5. **Gumming tendency:** Should have minimum gumming tendency to avoid reduced in flow area.
6. **Oxidation tendency:** Should have minimum oxidation tendency to avoid changed in oil characteristics.
7. **Corrosion resistance:** Should have high corrosion resistance to get longer life of the system.

2.15 Turbines

❖ **Hydro turbine:** It converts potential energy of water into mechanical energy or electric energy (AC).

• **Classification of Hydro Power Turbines:**

1. (Pelton turbine)-(Impulse turbine)-(High head & low quantity of water)-(10 to 35 rpm)
2. (Francis turbine)-(Reaction turbine)-(Medium head & Medium quantity of water)-(60 to 300rpm)
3. (Kaplan turbine)-(Reaction turbine)-(Low head & High quantity of water)-(120 to 1000rpm)

❖ **Wind turbine:** It converts kinetic energy of wind into mechanical energy or electric energy (DC).

• **Classification of Hydro Power Turbines:**

1. Small wind turbines: Less than 12 m in diameter and between 50 W and 50 KW outputs power.
2. Medium wind turbines: Up to 40 m in diameter and up to 750 KW outputs power.
3. Large wind turbine: : Greater than 40 m in diameter and up to 5 MW outputs power

❖ **Steam turbine:** It converts thermal energy of steam into mechanical energy.

• **Classification if steam Turbine:**

1. Impulse turbine
2. Reaction turbine
3. Combination of Impulse and reaction

- **Blades of turbine:**
 1. **Fixed blade (nozzle):** It converts potential energy of steam into kinetic energy.
 2. **Moving blade:** It converts that kinetic energy into mechanical energy.

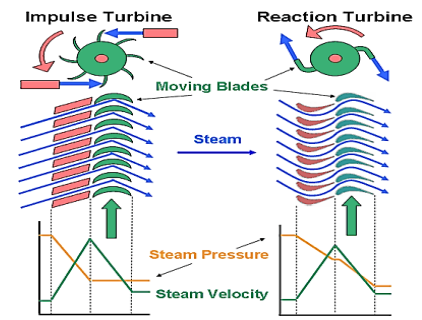

2.16 Tube and Pipe Requirements

❖ The piping system in steam power plant is divided into four categories:

1. Steam piping
2. Water piping
3. Blow-off piping
4. Others

❖ Requirements of steam piping system

1. Maximum reliability
2. Should be of necessary size
3. Withstand high pressure
4. Withstand high temperature and expansion
5. Avoid large number of joints

❖ Materials for tubes in condenser & feed water heater (FWH)

1. **Wrought Iron:** used for low and medium pressure range up to 250 psi (17 bar).
2. **Alloy Steel:** used for high temperature applications.
 - **Chromium steel pipes** used for temperature higher than 525°C to improve corrosion resistance.
 - **Molybdenum steel** used for temperature between 400- 525°C to improve creep strength.
 - **Nickel** is used to add toughness to the materials.
3. **Copper and Brass:** used for oil lines, but high in cost. The maximum pressure is limited to 20kg/cm².

❖ Properties of insulation of steam piping

1. Have high insulating efficiency
2. Not affected by moisture
3. Withstand high temperature
4. Have high strength

❖ **Types of piping joints:** It is used to connect multiple pipes.

1. **Threaded Joints:** Pipes are connected by screwing with the help of threads provided for each pipe. One pipe having internal threads and the other one having external threads. They are used for Cast iron pipes, copper pipes, PVC and G.I pipes. They are used in low temperature areas and low pressure flows.



2. **Brazed Joints:** Joining pipes using molten filler material at above 840°C. They are used for joining copper pipes or copper alloy pipes. Strength of brazed joint is low compared to other joints. They are used in moderate range of temperature areas.



3. **Soldered Joints:** They are similar to brazing but the filler metal melts at below 840°C. They are used to joint copper and copper alloy pipes. They are used for low temperature areas. They have low strength compared to brazed joints.



4. **Welded Joints:**

a) **Butt Welded Joints:** They are used for joining the pipes that have the same diameter. They are used for large commercials and industrial piping systems. They have good strength and they can resist high pressure. They are expensive and don't opened for maintenance.

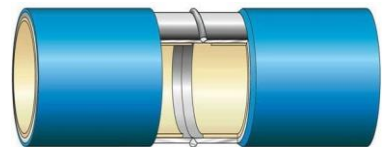

b) **Socket Welded Joints:** They are used when there is a high chance of leakage in joints. Pipes are connected as putting one into other and welded around the joint. They are used when Pipes having different diameters. They have lower cost than butt welding.

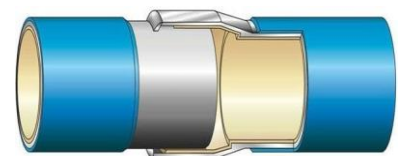

5. **Flanged Joints:** They are used for high pressure flows and for large diameter pipes. They are used for plain end pipes or threaded pipes. Two flange components are connected by bolts at the pipe joint to prevent leakage. They are made of cast iron, steel etc. they are having good strength and resist high pressure. They are also useful for repairing pipelines and maintenance.



6. **Compression Joints:** When the pipes have plain ends, they are joined by installing threaded fittings or couplings fittings at their ends. They can connect pipes of different materials and different sizes. Compression fittings are available in different materials and selection of fittings may depend upon our requirement.

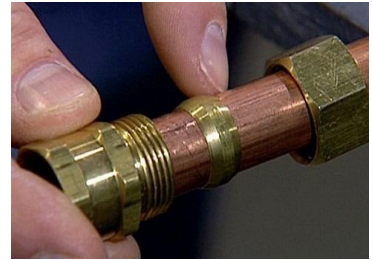

7. **Grooved Joints:** The pipe ends consist grooved edges which are connected by elastomer seal and then ductile iron made grooved couplings are used as lock for elastomer seal. These grooved couplings are connected by bolts. These joints are easy to install and economical. They have good resistance against pressure and they are used in moderate temperature areas. They are easily removable so, they are easily for maintenance.



CHAPTER 3

CHAPTER 3

Heat Transfer

3.1 Concept of Heat

S. No.	Quantity	SI Unit	Conventional Unit	Conversion Formula	Freezing/ Boiling point of water		
					Scale	Freeze	Boil
1	Temperature	kelvin (K)	degree Celsius ($^{\circ}\text{C}$), degree Fahrenheit ($^{\circ}\text{F}$)	$K = ^{\circ}\text{C} + 273.15$ $^{\circ}\text{F} = 1.8^{\circ}\text{C} + 32$	C	0°C	100°C
					K	273K	32°F
					F	373K	212°F
2	Heat	joule (J)	calorie (cal)	$1 \text{ cal} = 4.186 \text{ J}$			
3	Pressure	pascal (Pa)	atmosphere (atm)	$1 \text{ atm} = 10^5 \text{ Pa}$			
4	Volume	cubic metre (m^3)	litre (l)	$1 \text{ l} = 10^{-3} \text{ m}^3$			
5	Specific Heat Capacity	J/kg.K	J/kg. $^{\circ}\text{C}$, cal/kg. $^{\circ}\text{C}$				
6	Latent Heat	J/kg	cal/kg				

❖ Temperature:

- **Temperature** is the measure of hotness or coldness of an object.
- A temperature measured in **kelvin (K)** is called **absolute temperature**.
- **Absolute zero (or 0K)** is the temperature at which the **pressure** of gas becomes **zero**. $0 \text{ K} = -273.15^{\circ}\text{C}$
- **Melting Point:** The temperature at which a substance changes from solid phase to liquid phase
- **Boiling Point:** The temperature at which a substance changes from liquid phase to gas phase.
- **Light resulting from temperature** is called blackbody radiation, and ranges:

Red	-1000 K
Orange/Yellow	-3000 K
White or light Blue	-5000 K
- **Types of Flame:**
 1. Laminar, Premixed: fuel and air are mixed before the combustion. The flow is smooth. Example: Bunsen burner flame.
 2. Laminar, Diffusion: The fuel comes from the wax vapor and air mix after diffusion into the flame. Example: candle.
 3. Turbulent, Premixed: air and fuel are premixed in burner like boiler or furnace.
 4. Turbulent, Diffusion: It is the most unwanted fires .no burner or other mechanical device for mixing fuel and air.
- **Combustion Requirements:** the combustion required three elements for combustion and if one of these three elements is removed, the combustion will stop.
 1. Fuel
 2. Heat (ignition)
 3. Air
- **Example:** Find the equivalent temperature on the indicated scale: **(a)** -273.15°C on the Fahrenheit scale, **(b)** 98.6°F on the Celsius scale, and **(c)** 100 K on the Celsius scale and Fahrenheit scale.

Sol: (a) $\because ^{\circ}\text{F} = 1.8^{\circ}\text{C} + 32 \Rightarrow ^{\circ}\text{F} = 1.8 \times (-273.15) + 32 = -459.67 \Rightarrow -273.15^{\circ}\text{C} = -459.67^{\circ}\text{F}$.

$$(b) \because ^\circ\text{F} = 1.8^\circ\text{C} + 32 \Rightarrow ^\circ\text{C} = \frac{^\circ\text{F} - 32}{1.8} \Rightarrow ^\circ\text{C} = \frac{98.6 - 32}{1.8} = 37 \Rightarrow \mathbf{98.6^\circ\text{F} = 37^\circ\text{C}}$$

$$(c) \text{K} = ^\circ\text{C} + 273.15 \Rightarrow ^\circ\text{C} = \text{K} - 273.15 \Rightarrow ^\circ\text{C} = 100 - 273.15 = -173.15 \Rightarrow \mathbf{100 \text{ K} = -173.15^\circ\text{C}}$$

$$\text{and } ^\circ\text{F} = 1.8^\circ\text{C} + 32 \Rightarrow ^\circ\text{F} = 1.8 \times (-173.15) + 32 = -279.67 \Rightarrow \mathbf{100 \text{ K} = -279.67^\circ\text{F}}$$

❖ Specific Heat or Specific Heat Capacity in Gases, liquids and solids

- It is the energy required to raise the temperature of a unit mass of a substance by one degree.
- Specific Heat **depends** on **material** of the object and doesn't depend on its mass.
- Specific heat at constant volume " C_v " and specific heat at constant pressure " C_p "
- C_p is greater than C_v because at constant pressure the system is allowed to expand and required energy.
- Meyer's Equation: $C_p - C_v = R$
- Unit: $\frac{\text{kJ}}{\text{kg}} \cdot ^\circ\text{C}$
- Amount of **heat** needed to **change temperature** of an object is $Q = m C \Delta T$, Here, m = mass of object, C = Specific Heat, ΔT = change in temperature = $T_f - T_i$
- Example:** Calculate the specific heat of copper if 1935 J of heat increases the temperature of 1kg of copper by 5°C .

Specific Heats of Some Materials at Atmospheric Pressure

Substance	J/kg·°C	cal/g·°C
Aluminum	900	0.215
Beryllium	1 820	0.436
Cadmium	230	0.055
Copper	387	0.0924
Germanium	322	0.077
Glass	837	0.200
Gold	129	0.0308
Ice	2 090	0.500
Iron	448	0.107
Lead	128	0.0305
Mercury	138	0.033
Silicon	703	0.168
Silver	234	0.056
Steam	2 010	0.480
Water	4 186	1.00

Sol: Here $Q = 1935 \text{ J}$, $m = 1\text{kg}$, $\Delta T = 5^\circ\text{C}$. $\therefore Q = mC\Delta T \Rightarrow C = \frac{Q}{m\Delta T} = \frac{1935}{1 \times 5} = 387 \text{ J/kg}\cdot^\circ\text{C}$

❖ Heat

- The **energy that flows** between objects due to their **temperature difference** is called **Heat**.
- Each molecule** (or atom) of an object has **kinetic energy (KE)** and **potential energy (PE)**.
- Internal energy (U)** of an object is the **sum of kinetic energy and potential energy** of all the **molecules (or atoms)** of the object. $U = (KE + PE)_{\text{all molecules}}$
- If two objects are in thermal contact but **no net flow of heat is between them** then they are in **thermal equilibrium** \Rightarrow **Temperature** of the two objects is **same**.
- If an object **takes heat**, its **internal energy increases**; if an object **gives heat**, its **internal energy decreases**.
- If due to transfer of heat the **potential energy of the molecules changes** by definite amount then **phase of the object changes**.
- If due to transfer of heat the **kinetic energy of the molecules changes** then **temperature of the object changes**.
- 1 calorie** is the heat energy that can raise the temperature of **1g** of **water** by **1°C**.

- Principle of Calorimetry:** If a cold body is put in thermal contact with a hot body then at thermal equilibrium.

Heat gained by cold body = Heat lost by hot body.

$$Q_c = -Q_h$$

$$m_c C_c (T_E - T_c) = -m_h C_h (T_E - T_h)$$

Here, m_c =mass of cold body, C_c =specific heat of cold body, T_c =temperature of cold body, m_h =mass of hot body, C_h =specific heat of hot body, T_h =temperature of hot body and T_E =equilibrium temperature.

- **Example:** Temperature of 0.05 kg of iron is raised to 200 °C and then dropped into a calorimeter containing 0.35kg of water at 20 °C. If the final temperature is 22.4 °C, find specific heat capacity of iron.

Sol: Here **iron** is **hot body** and **water** is **cold body**

$$\Rightarrow m_c = 0.35 \text{ kg}, C_c = 4186 \text{ J/kg}\cdot^\circ\text{C}, T_c = 20^\circ\text{C}, m_h = 0.05 \text{ kg}, C_h = ?, T_h = 200^\circ\text{C} \text{ and } T_E = 22.4^\circ\text{C}.$$

$$\therefore m_c C_c (T_E - T_c) = -m_h C_h (T_E - T_h) \Rightarrow C = \frac{Q}{m \Delta T} = \frac{1935}{1 \times 5} = 387 \text{ J/kg}\cdot^\circ\text{C} \text{ (Ans: } 395.97 \text{ J/kgC)}$$

❖ Phase Change:

- Change of a solid into liquid (**melting**), change of a liquid into solid (**fusion**), change of a liquid into gas (**vaporization**), and change of a gas into liquid (**condensation**) are the instances of phase change.

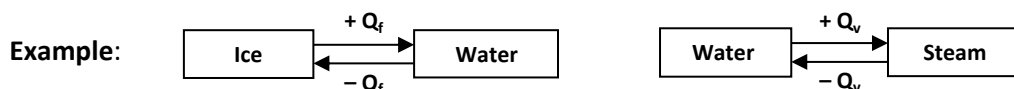

- In a **phase change**, only the **potential energy** of the **molecules** changes (and there is no change in kinetic energy of the molecules or temperature of the object).

❖ Latent Heat (L):

- **Latent Heat** is the amount of heat that changes the phase of **1kg** of a substance without changing its temperature.

- Heat required for phase change is $Q = \pm mL$

Where m = mass of the object and L = latent heat of the substance.

- **Latent heat of fusion (L_f)** is the heat energy associated with **melting or fusion**.

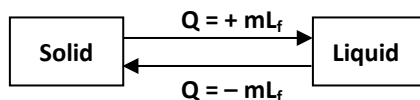

- **Latent heat of vaporization (L_v)** is the heat energy associated with **boiling or condensation**.

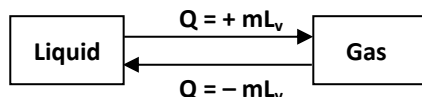

If change in temperature $\Rightarrow Q = m\Delta T$ $\begin{cases} + \text{ if } \Delta T = + \text{ (when object takes heat)} \\ - \text{ if } \Delta T = - \text{ (when object gives heat)} \end{cases}$

If change in phase $\Rightarrow Q = mL$ $\begin{cases} + \text{ if change is from solid to liquid or from liquid to gas} \\ - \text{ if change is from liquid to solid or from gas to liquid} \end{cases}$

Latent Heats of Fusion and Vaporization

Substance	Melting Point ($^\circ\text{C}$)	Latent Heat of Fusion (J/kg)	Latent Heat of Fusion (cal/g)	Boiling Point ($^\circ\text{C}$)	Latent Heat of Vaporization (J/kg)	Latent Heat of Vaporization (cal/g)
Helium	-269.65	5.23×10^3	(1.25)	-268.93	2.09×10^4	(4.99)
Nitrogen	-209.97	2.55×10^4	(6.09)	-195.81	2.01×10^5	(48.0)
Oxygen	-218.79	1.38×10^4	(3.30)	-182.97	2.13×10^5	(50.9)
Ethyl alcohol	-114	1.04×10^5	(24.9)	78	8.54×10^5	(204)
Water	0.00	3.33×10^5	(79.7)	100.00	2.26×10^6	(540)
Sulfur	119	3.81×10^4	(9.10)	444.60	3.26×10^5	(77.9)
Lead	327.3	2.45×10^4	(5.85)	1 750	8.70×10^5	(208)
Aluminum	660	3.97×10^5	(94.8)	2 450	1.14×10^7	(2 720)
Silver	960.80	8.82×10^4	(21.1)	2 193	2.33×10^6	(558)
Gold	1 063.00	6.44×10^4	(15.4)	2 660	1.58×10^6	(377)
Copper	1 083	1.34×10^5	(32.0)	1 187	5.06×10^6	(1 210)

3.2 heat Transfer

❖ Heat transfer

- It is study of thermal energy transfer causing a temperature difference or gradient.
- Energy can transfer from or to a given mass by two mechanisms: heat **Q** and work **W**.
- The energy interaction is heat transfer if its driving force is temperature difference, otherwise it's work.
- A rising piston, a rotating shaft, and an electrical wire crossing are all associated with work interactions.
- **Total Heat transfer (Q):** $Q = mC_{ave}\Delta T \text{ J}$ **rate of heat transfer (\dot{Q}):** $\dot{Q} = \frac{Q}{\Delta t} \text{ J/s or W}$

❖ Thermodynamics Vs Heat transfer

<u>Thermodynamics</u> tells about	<u>Heat transfer</u> tells about
<ul style="list-style-type: none"> • How much heat is transferred • How much work is done • Final state of the system 	<ul style="list-style-type: none"> • How heat is transferred • At what heat is transferred • Temperature distribution inside the body

❖ Driving forces

- The driving force for heat transfer is **the temperature difference**.
- The driving force for electric current flow is **the voltage difference**.
- The driving force for fluid flow is **the pressure difference**.

❖ Energy transfer

- Energy can transferred from or to a given mass by two mechanisms: heat **Q** and work **W** .
- The energy interaction is heat transfer if its driving force is a temperature difference, otherwise it's work
- A rising piston, a rotating shaft, and an electrical wire crossing are all associated with work interactions.

❖ Heat Flex

- It is the heat transfer per unit time per unit area.
- $q = \frac{\dot{Q}}{A} \text{ W/m}^2$

❖ Methods of heat transfer

1. Conduction:

- It is the heat transfer from one substance to another by direct contact.
- Fourier's law of heat conduction:

$$\dot{Q}_{conduction} = kA \frac{T_1 - T_2}{\Delta x} = -kA \frac{\Delta T}{\Delta A} = -kA \frac{dT}{dX} \text{ Watt}$$
- **K (Thermal conductivity):**
 - a) It is the rate of heat transfer per unit area per unit temperature difference.
 $W/m \text{ } ^\circ C$
 - b) High thermal conductivity means that the substance has good conductor and vice versa
 - c) Thermal conductivity of substance depends on the chemical composition, phase (liquids is more than the gasses and the metals have the highest), crystalline structure (if solid), temperature (K of the metal decreases when temperature increased and decreased in fluid), pressure, and homogeneity.
 - d) Thermal conductivity is affected by the phase change.
- **A (Area):** Heat transfer increased when the area increases and vice versa.
- $\frac{dT}{dX}$ **(Temperature gradient):** Heat transfer increased when the temperature gradient increases.
- Δx **(Thickness):** Heat transfer decreased when the thickness decreases and vice versa.

- **Thermal diffusivity (α):**
 - a) It is the ratio of thermal conductivity to the heat stored. Heat stored is the product ρC_p
 - b) $\alpha = \frac{k}{\rho C_p}$, k is thermal conductivity, ρ is the density, and C_p is specific heat.
 - c) Materials with high thermal conductivity or low heat stored will have large α .

2. Convection:

- It is the heat transfer within a fluid caused molecular motion or between solid surface and moving fluid.
- Newton's law of cooling: $\dot{Q}_{convection} = hA_s(T_s - T_\infty)$ **Watt**
 h is the convection heat transfer coefficient, A_s is the surface area, T_s is the surface temperature, T_∞ is the temperature of the fluid that far from the surface.
- **Forced convection:** The fluid forced to flow by external force like a fan, pump, or wind.
- **Natural (or free) convection:** The fluid motion is caused by temperature difference.
- **Internal convection:** The fluid flow in a pipe or channel.
- **External convection:** The fluid flow over a surface.

3. Radiation:

- It is the heat transfer between two substances that are not in contact.
- Stefan-Boltzmann law: the emissivity of blackbody is directly proportional to the fourth power of absolute temperature.
- $\dot{Q}_{radiation} = \epsilon \sigma A_s (T_s^4 - T_\infty^4)$ **Watt**. Stefan-Boltzmann constant $\sigma = 5.67 \times 10^{-8} \text{ W/m}^2 \text{ K}^4$,
 A_s is the surface area, T_s is the absolute temperature, ϵ is the emissivity.
- **Blackbody:** The idealized surface that emits radiation at this maximum rate, and the radiation emitted by a blackbody is called **blackbody radiation**. For blackbody $\epsilon = 1, \alpha = 0, \rho = 0$
- **Properties of Radiation:**
 - a) **Emissivity (ϵ)** is the ratio of the radiation emitted by a surface to the radiation emitted by a blackbody at the same temperature.
 - b) **Absorptivity (α)** is the fraction of radiation absorbed by a surface.

$$\alpha = \frac{Q_{Absorbed}}{Q_{Incident}}$$
 - c) **Reflectivity (ρ)** is the fraction reflected by the surface. $\alpha = \frac{Q_{Reflected}}{Q_{Incident}}$
 - d) **Transmissivity (τ)** is the fraction transmitted by the surface. $\alpha = \frac{Q_{Transmitted}}{Q_{Incident}}$

$$\alpha + \rho + \tau = 1$$
- **The Kirchhoff's law of radiation:** The emissivity and the absorptivity of a surface are equal at the same temperature and wavelength. $\epsilon_1 = \alpha_1; \epsilon_2 = \alpha_2 \dots$

❖ Heat generation

- It is conversion of electrical, nuclear, or chemical energy into heat or thermal energy.
- $\dot{G} = \dot{g}V$ or **IV Watt**, \dot{g} is the constant rate of heat generation per unit volume (W/m^3), V is the volume, I is the current, and V is the voltage.

CHAPTER 4

CHAPTER 4

Mechanics of

Machines

4.1 Newton's Laws – Kinematics – Kinetics

- **Mechanics of Machines:** It's study of motion and forces between various parts of a machine.
- **Machine:** It's a device which receives energy from some sources and uses it to do some useful work

❖ Sub-divisions of mechanics of machines:

- Kinematics:** It studies of motion between various parts of a machine without studies of force.
- Dynamics:** It studies of forces of the moving parts of machines.
- Kinetics:** It studies of inertia forces come from both mass and motion of moving parts of machines.
- Statics:** It studies of forces of the rest parts of machines.

Basics of SI units:

v	Velocity	m/s
a	Acceleration	m/s ²
s	Displacement	m
ω	Angular velocity	Rad/s
α	Angular acceleration	Rad/s ²
θ	Angular displacement	rad
ρ	Density	Kg/m ³
F,W	Force, weight	Kg.m/s ² or N
p	Pressure	N/m ² or Pa
W,E, M, T	Work, Energy, Moment of Force, Torque	N.m or J
P	Power	J/s or Watt
M	Mass	kg
P	Momentum	Kg.m/s
I	Moment of Inertia	Kg.m ²
q	Electric charge	coulomb (C)
V	Electric Voltage	volt (v)
I	Electric Current	ampere (A)
R	Electric Resistance	Ohm (Ω)
C	Electric Capacitance	farad (F)
B	Magnetic field	tesla (T)
L	Inductance	henry (H)
f	Frequency	Hertz (Hz)

Prefixes used in SI units

Power	Prefix	symbol
10 ⁻²⁴	yocto	y
10 ⁻²¹	zepto	z
10 ⁻¹⁸	atto	a
10 ⁻¹⁵	femto	f
10 ⁻¹²	pico-	P
10 ⁻⁹	nano-	N
10 ⁻⁶	micro-	M
10 ⁻³	milli-	M
10 ⁻²	centi-	C
10 ⁻¹	deci-	D
10 ¹	deka-	da
10 ³	kilo-	K
10 ⁶	mega-	M
10 ⁹	giga-	G
10 ¹²	tera-	T
10 ¹⁵	peta	P
10 ¹⁸	exa	E
10 ²¹	zetta	Z
10 ²⁴	yotto	Y

some conversion of units

1 kg	2.2 Pounds
1 kg	35.27 Ounces
1 foot	30.5 cm
1 foot	12 inch
1 inch	2.54 cm
1 mile	1.61 Km
1 calories	1.026 Pound
1 knot	6068 feet
1 league	3 knot
1 yard	36 inch
1 yard	3 feet
1 decimeter	10 cm
1 gallon	3.8 liters
1 oil barrels	42 gallons
1 fluid barrels	31.5 gallons
1 tons	1000 kg
1 tons	7.3 oil barrels
1 acre	4200 m ²
1 hectare	100,000 m ²
1 century	10 years

❖ Newton's Laws of motion:

- **Newton's first law:** everybody continuous of rest or motion until acted by external force.
- **Newton's second law:** The rate of change in momentum (Force) is directly proportional to the acceleration. $F = (mv - mu)/t = m(v - u/t) = ma$
- **Newton's third law:** To every action there is always an equal and opposite reaction.

❖ Plane motion: The motion of body moves to only one plane.

• Types of plane motion:

- Rectilinear motion:** When a body is moving in straight line path.
- Curvilinear motion:** When a body is moving along curved path.

❖ Linear velocity: It is the rate of change of linear displacement to the time. $v = \frac{ds}{dt}$ m/s

❖ Linear Acceleration: It is the rate of change of linear velocity to the time. $a = \frac{dv}{dt} = \frac{d^2s}{dt^2}$ m/s²

❖ Equation of linear motion:

- $v = u + at$
- $s = ut + \frac{1}{2}at^2$
- $v^2 = u^2 + 2as$
- $s = ((u + v)t) / (2) = v_{av}t$

- ❖ **Angular velocity:** It is the rate of change of angular displacement to the time. $\omega = \frac{d\theta}{dt} \text{ rad/s}$
- ❖ **Angular acceleration:** It is the rate of change of linear velocity to the time. $\alpha = \frac{d\omega}{dt} = \frac{d^2\theta}{dt^2} \text{ rad/s}^2$

❖ **Equation of angular motion:**

- $\omega = \omega_0 + \alpha t$
- $\theta = \omega_0 t + \frac{1}{2} \alpha t^2$
- $\omega^2 = \omega_0^2 + 2\alpha\theta$
- $\theta = ((\omega_0 + \omega)t) / (2) = \omega_{av} t$

- ❖ If a body is rotating at the speed of **N r.p.m.** (revolutions per minute), then $\omega = 2\pi N/60 \text{ rad/s}$

❖ **Relationship between Linear and Angular motion:**

- Linear velocity: $v = r \cdot \omega \text{ m/s}$
- Linear acceleration: $a = r \cdot \alpha \text{ m/s}^2$

- ❖ **Acceleration of a particle along a circular path:** When a particle moves along a circular path, it has two components of acceleration.

1. **Tangential component:** $a_t = r \cdot \alpha \text{ m/s}^2$
2. **Normal component:** $a_n = \omega^2 \cdot r \text{ m/s}^2$

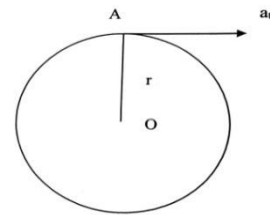

Total acceleration: $a = \sqrt{(a_t^2 + a_n^2)}$

Inclination between acceleration: $\tan\theta = a_n/a_t$

❖ **Oscillatory motion of a particle:**

- **Simple Harmonic Motion (S.H.M):** It is a to and fro motion. In S.H.M, the acceleration is directly proportional to its distance. Ex of S.H.M: oscillations of a pendulum, motion of piston in an engine cylinder.
- **Oscillation:** a body moves to and fro motion from mean position to one end position, then to the other end position and back to the mean position.
- **Amplitude:** Maximum displacement of the body from its mean position.
- **Time Period:** Time taken to complete one oscillation. $T = 2\pi/\omega$
- **Frequency: Number of oscillations per second.** $f = \frac{1}{T}$

- ❖ **Mass:** It is the amount of matter contained in a body. It doesn't change when positions change.

- ❖ **Weight:** It is the product of mass & gravity acceleration. It changes when positions change. $W = mg \text{ N}$

- ❖ **Momentum:** it is the product of mass and velocity of a body. $Momentum = mv \text{ kg} \cdot \frac{m}{s}$

- ❖ **Law of conservation of momentum:** Total momentum remains same if no external force acts.

$$\text{Initial momentum} = \text{final momentum} \quad m_1 u_1 + m_2 u_2 + \dots = m_1 v_1 + m_2 v_2 + \dots$$

- ❖ **Impulse:** It is the product of force and time. $Impulse = Ft \text{ or } m\Delta v \text{ N} \cdot s$

- ❖ **Force:** It is the rate of change in momentum. $F = ma \text{ kg} \cdot m/s^2$

- **Concurrent force:** Two or more forces are action intersect at the same point. Ex: Pull Rope
- **Non-concurrent force:** Two or more forces have equal magnitudes, but act in opposite direction. Ex: Couple.

- ❖ **Moment of Force:** It is the product of force and perpendicular distance. $M = F \times L \text{ N} \cdot m \text{ or } J$

- ❖ **Couple:** Two equal and opposite forces form a couple. $Moment \text{ of couple} = F \times X$

- ❖ **Centripetal and Centrifugal Forces:** If a particle moves in a circular path, there are two forces keeping the particle in path.

1. **Centrifugal force acts outwards:** $F = m\omega^2 r$, r = radius, m = mass, ω = angular velocity

2. **Centripetal force acts inwards:** $F = m \frac{v^2}{r}$, $\frac{v^2}{r}$ = centripetal acceleration

❖ **Moment of Inertia:** It is the product of mass & square of the perpendicular distance. $I = mk^2$ $kg.m^2$
 k =radius of gyration

❖ **Torque:** It is the moment of force. It is the product of force and perpendicular distance.

$$T = F.r \text{ N.m or J} \quad \text{For rotation bodies: } T = I.\alpha \text{ N.m or J}$$

❖ **Work:** It is the product of force and displacement.

$$W = F.X \text{ N.m or J} \quad \text{For rotation bodies: } W = T.\theta \text{ N.m or J}$$

- Work done on moving a body is equal to its change in Kinetic Energy ($\Delta K.E$).
- Work done on lifting a body is equal to its change in Potential Energy ($\Delta P.E$).

❖ **Power:** It is the rate of doing work or work done per unit time.

$$P = \frac{\text{Work done}}{\text{time}} = \frac{W}{t} \text{ J/s or Watt (1 hp=746 W), For rotation bodies: } P = T.\omega \text{ J/s or Watt}$$

❖ **Energy:** It is the capacity to do work. There are different forms of energy like mechanical energy, electrical energy, chemical energy, heat energy, light energy, wind energy, etc.

- **Law of energy conservation:** Total energy in the universe is constant. $KE + PE = \text{constant}$
Or energy cannot be created or destroyed but it can be converted from one form to other.

- **Potential Energy:** It is the energy due to the position of the body. $P.E = mgh \text{ N.m or J}$

- **Strain Energy:** It is the energy due to deformed of the body.

$$S.E = \frac{1}{2} SX^2 \text{ N.m or J}, S=\text{Stiffness in N/m, } x=\text{distance in m}$$

- **Kinetic Energy:** It is the energy due to motion of the body.

$$K.E = \frac{1}{2} mv^2 \text{ N.m or J} \quad \text{For rotation bodies: } K.E = \frac{1}{2} I\omega^2 \text{ N.m or J}$$

❖ **Efficiency of a Machine:** It is the ratio of output power to the input power. $\eta = \frac{\text{Output}}{\text{Input}}$ *No unit*

4.2 Concepts of Mechanisms

- Machines are devices which use energy to do some useful work.
- Machines are made using parts or bodies or links.
- Machines use mechanisms to get the required motion.

❖ **Kinematic Link or Element:** It is a part of machine which has relative motion and resistant body.

❖ **Resistant body:** It is transmission the required motion with negligible deformation.

❖ **Types of Links:**

1. **Rigid Link:** It is a link or a body which can transmit motion with no deformation. Ex: Connecting rod or Crank.
2. **Flexible Link:** It is a link or a body which can transmit motion with partly deformation. Ex: Belt, Rope, Chain.
3. **Fluid Link:** The transmission of motion takes place though fluid under pressure. Ex: Hydraulic presses, Jacks and Brakes.

❖ **Structure:** It is an arrangement of group of resistant bodies having no relative motion between them.

Ex: Railway, Bridge, machine frame.

❖ **Difference between Machine and Structure:**

Machine	Structure
• Parts move relative to another	• Parts don't move relative to another
• Transfer energy into useful work	• Doesn't Transfer energy into useful work
• Links transmit both power and motion	• Links transmit forces only

- ❖ **Kinematic Pair:** The motion between two links or elements that contact with each other is completely constrained or successfully constrained.
- ❖ **Types of constrained motions:**
 1. **Completely constrained motion:** The motion between pair is limited to one direction. Ex: Square bar in a square hole.
 2. **Incompletely constrained motion:** The motion between pair can take place in more than one direction. Ex: Shaft in a circular hole.
 3. **Successfully constrained motion:** The motion between pair is not completed by itself, but by external force. Ex: Foot step bearing.
- ❖ **Classification of kinematic pairs:**
 1. **According to the type of relative motion between the elements:**
 - a) **Sliding pair:** When two elements of pair are connected and one slides to other fixed link. Ex: Piston and cylinder.
 - b) **Turning pair:** When two elements of pair are connected and one turns about other fixed link. Ex: shaft fitted into a circular hole.
 - c) **Rolling pair:** When two elements of pair are connected and one rolls over other fixed link. Ex: Ball and roller bearing.
 - d) **Screw pair:** When two elements of pair are connected and one turns about other link by screw threads. Ex: bolt and nut.
 - e) **Spherical pair:** When two elements of pair are connected and one turns about other fixed link. Ex: attachment of car mirror, Ball and socket joint.
 2. **According to the type of contact between the elements:**
 - a) **Lower pair:** When two elements of pair have a surface contact and motion between them is turning or sliding. Ex: Sliding pairs, Turning pairs and Screw pairs.
 - b) **Higher pair:** When two elements of pair have a point or line contact and motion between them is partly turning and partly sliding. Ex: Toothed gearing, belt and rope drives.
 3. **According to the type of closure:**
 - a) **Self-closed pair:** When two elements of pair are connected together mechanically. Ex: Lower pair.
 - b) **Forced closed pair:** When two elements of pair not connected together mechanically, but they are kept in contact by external forces. Ex: Cam & Follower.
- ❖ **Kinematic Chain:** Kinematic pairs are joined that last link is joined to the first link to transmit motion.
- ❖ **Types of joints:**
 1. **Binary joint:** If two links are jointed at the same point.
 2. **Ternary joint:** If three links are jointed at the same point.
 3. **Quaternary joint:** If four links are jointed at the same point.
- ❖ **Mechanism:** In a kinematic chain, if one of the links is fixed. Ex: Engine indicators, typewriter.
 - **Types of mechanism:**
 1. **Simple mechanism:** If the mechanism has only four links.
 2. **Compound mechanism:** If the mechanism has more than four links.

4.3 Computer Simulation of Mechanisms

- It is creating a mechanism model in the computer to see how it works by changing different parameters.
 - ❖ **Advantages of computer simulation of mechanisms:**
 - Easy and quick to make models and test in computers.
 - Low cost compared to actual testing.
 - Problems complex can be analyzed before making the real mechanisms.
 - ❖ **Steps of computer simulation of mechanisms:**
 1. Creating the model of different parts of the mechanisms
 2. Assembling the parts
 3. Applying the parameters to different parts
 4. Running the model
 5. Observing the results of working of mechanisms
 6. If the mechanism doesn't work, change the parameters and check until it works.
 7. Use the data for making the real time mechanisms
 - ❖ **Common software used for computer simulation of mechanisms:**
 1. ADAMS - Automatic Dynamic Analysis of Mechanical System
 2. ANSYS – Analysis of System
 3. Pro-Engineer
 4. CATIA – Computer Aided Three-Dimensional Interactive Application
 5. UG – Unigraphics
 6. Autodesk – Inventor
-

4.4 Balancing of Rotating and Reciprocating Masses

- **Balancing** is the process of designing a machine in which unbalance force is minimum.
 - Machines and Engines have moving elements or parts. Some of them are rotating and some of them are reciprocating. These parts should be balanced. If the parts in a machine are not balanced, unbalanced forces setup in the machine and they increase the loads on machine parts and also create stresses and vibrations in the machine parts.
 - ❖ **Balancing of Rotating Masses:**
 - When any the part is rotating, it produced centrifugal force. If this centrifugal force is unbalanced then it bends the parts of the machine. To balance this unbalanced centrifugal force, a mass is attached opposite side of the part to balance the centrifugal force.
 - ❖ **Balancing of Reciprocating Masses:**
 - There are various forces acting on the reciprocating parts of an engine. The resultant of all the forces is known as unbalanced force or shaking force. If the resultant is zero, then there is no unbalanced force. And if the resultant increased, then the unbalanced force will increase.
-

4.5 Cams and Followers

- There are several machine elements used to transmit the power from one part to other. Ex: gears, belts, cams, chains etc.
- **Cams:** It is a component of machine that is used to transmit motion to another component called follower. It is used to transform a rotary motion into a translating or oscillating motion.
- **A cam mechanism** consists of three elements: the cam, the follower and the frame.

❖ **Applications of Cams:**

1. Opening and closing of valves in IC engines
2. Paper cutting machinery
3. Making clothes machinery (Textile machinery)
4. Automatic lath machine
5. Printing presses
6. Food processing machinery

❖ **Classification of followers**

1. **According to the surface of contact**

a) **Knife Edge Follower:** If the contacting end of the follower is knife edge. It is used in applications where low force is applied on follower and cam rotates with low speeds.

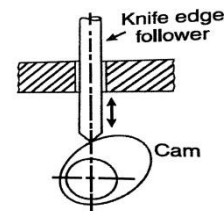

b) **Roller follower:** If the contacting end of the follower is roller. It is used in stationary gas engines and aircraft engines where high force on follower and high speed of cam.

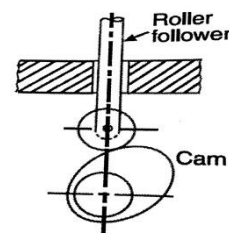

c) **Flat faced follower:** If the contacting end of the follower is flat face. It is used in automobile IC engines where medium force is applied on follower and cam rotates with medium speeds.

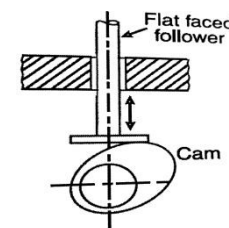

d) **Spherical faced follower:** If the contacting end of the follower is spherical shape. It is used in automobile engines where medium force is applied on follower and cam rotates with medium speeds. The flat end of the follower is machined to a spherical shape reduced surface stresses.

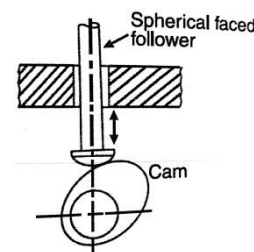

2. **According to the motion of follower**

a) **Reciprocating or translating follower:** when the uniform rotary motion of the cam is converted into reciprocating motion of the follower.

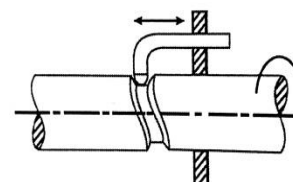

b) **Oscillating or rotating follower:** when the uniform rotary motion of the cam is converted into oscillating motion of the follower.

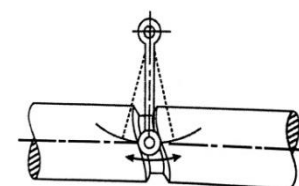

3. According to the path of motion of the follower

a) **Radial follower:** When the motion of the follower is passing through the axis of the cam center.

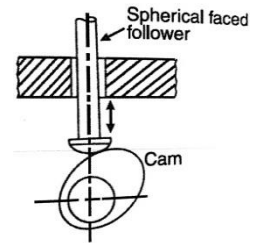

b) **Offset follower:** When the motion of the follower is passing away from the axis of the cam center.

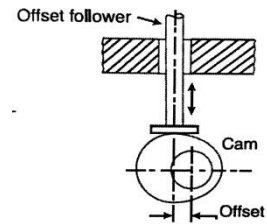

❖ Classification of Cams:

1. **Radial Cam or Disc Cam:** The reciprocating or oscillating follower is perpendicular to the cam axis.

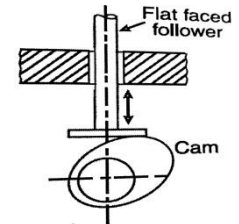

2. **Cylindrical Cam:** The reciprocating or oscillating follower is parallel to the cam axis.

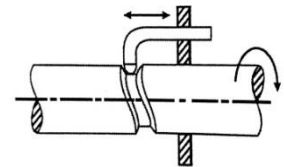

❖ Motion of follower

1. Uniform velocity
2. Simple harmonic motion
3. Uniform acceleration and retardation
4. Cycloidal motion

4.6 Gears Drives

- They are mechanical elements that are used to transmit the power from one shaft to another.

❖ Types of Gears

1. **Spur Gears:** The teeth of the gear are cut parallel to the axis of the wheel. They are used to transmit power when shafts are parallel.

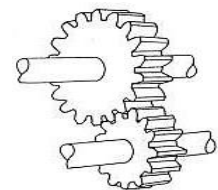

2. **Helical Gears:** The teeth of the gear are cut inclined to the axis of the wheel. They are used to transmit power when shafts are parallel. They have more contact area compared to spur gears, so they run smoothly with less noise.

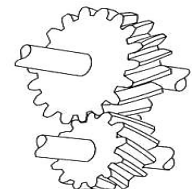

3. **Herringbone Gears (Double helical gears):** The teeth of the gear are cut inclined to the axis of the wheel in two sides. They are used to transmit power when shafts are parallel. They are used to reduce thrust force on gear shafts.

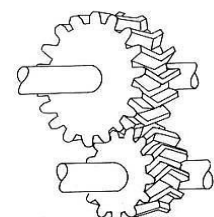

4. **Bevel Spur Gears:** Wheel is made in bevel shape and the teeth of the gear are cut around the bevel surface of the wheel. . They are used to transmit power when the angle between shafts is 90°.

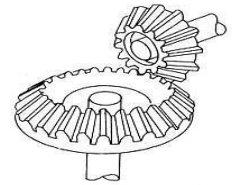

5. **Bevel Helical Gears:** Wheel is made in bevel shape and the teeth of the gear are cut inclined around the bevel surface of the wheel. They have more contact area compared to the bevel gears, so they run smoothly with less noise. They are used to transmit power when the angle between shafts is 90°.

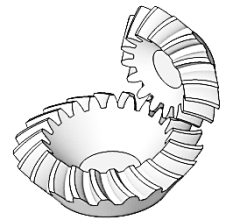

6. **Worm Gears:** the teeth of the gear are cut in spiral shape around the wheel. They are used to transmit power when the angle between shafts is 90° and high reductions in velocities are required.

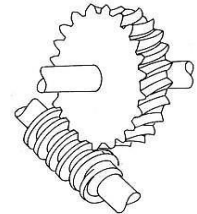

7. **Rack and Pinion:** If the teeth are cut on straight surface it is called **Rack**. If the teeth are cut on circular surface it is called **Pinion**. The combination is called **Rack and Pinion**. They are used to convert the rotary motion into reciprocating motion and vice versa.

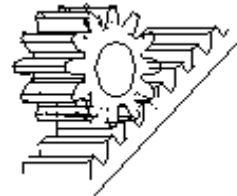

❖ **Advantages of gear drives:**

- They can transmit large powers
- They can transmit exact velocity ratios
- They have reliable service

❖ **Disadvantages of gear drives**

- Manufacturing of gears required special tools and equipment
- Errors in cutting teeth cause vibrations

❖ **Simple Gear Train**

- There is only one gear on each shaft.
- Speed of gear is inversely proportional to the number of teeth.
- **Speed ratio:** Speed of the driver to the driven. $\frac{N_1}{N_2} = \frac{T_2}{T_1}$
- **Train value:** Speed of the driven to the driver. $\frac{N_2}{N_1} = \frac{T_1}{T_2}$

N_1 = Speed of the driver in rpm
 N_2 = Speed of the driven in rpm
 T_1 = Number of the teeth on gear 1
 T_2 = Number of the teeth on gear 2

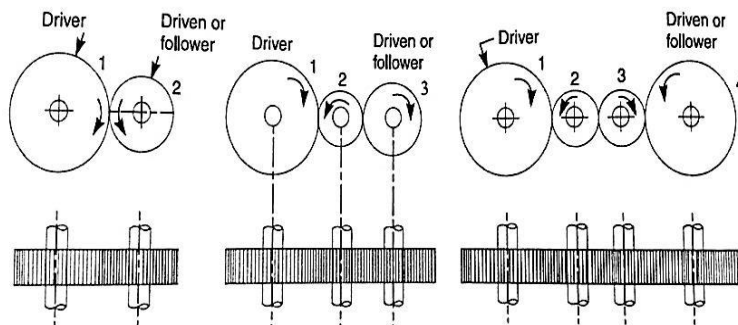

❖ Compound Gear Train

- There is more than one gear on each shaft.
- They are used when speed changes are required between two shafts.

- **Speed ratio** =
$$\frac{\text{Speed of the first driver}}{\text{Speed of the last driver}} = \frac{\text{Product of the number of teeth on the drivers}}{\text{Product of the number of teeth on the driven}}$$

$$= \frac{N_1}{N_6} = \frac{T_2 \times T_4 \times T_6}{T_1 \times T_3 \times T_5}$$

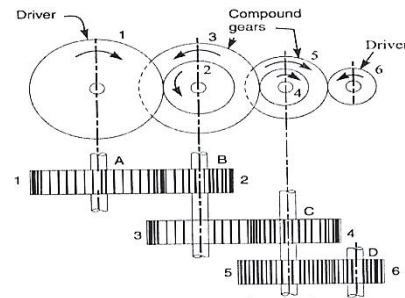

- **Train value:** Speed of the last driven to the first driver.
$$\frac{N_6}{N_1} = \frac{T_1 \times T_3 \times T_5}{T_2 \times T_4 \times T_6}$$

❖ Epicyclic Gear Train

- They are used to transmit high velocity ratios with less space.
- They are used in Lathes, differential gears of automobiles, wrist watches etc.
- It has gear A, gear B and arm C. If the arm C is fixed, it acts like a simple gear train.
- If the gear A is fixed, then the arm and gear B can rotate clockwise or anticlockwise around the gear A, it is called **Epicyclic motion**.

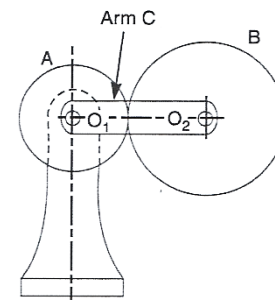

• Table of Motions:

Step No.	Condition of motion	Revolution of elements		
		Arm C	Gear A	Gear B
1.	Arm fixed, Gear A rotates +1 rev anticlockwise	0	+1	$-\frac{T_A}{T_B}$
2.	Arm fixed, Gear A rotates +1 rev anticlockwise	0	+x	$-x \frac{T_A}{T_B}$
3.	Add +y rev to all elements	+y	+y	+y
4.	Total motion	+y	x + y	$y - x \frac{T_A}{T_B}$

4.7 Belt Drives

- It is a loop of flexible material used to link two of rotating shafts for transmission of motion or power.

❖ Selection of a belt drive: It depends upon the following factors:

1. Speed of driving and driven shafts
2. Speed reduction ratio
3. Power to be transmitted
4. Positive drive requirements
5. Shafts layout

❖ Types of belt drives

1. According to the speed of belt drives

- a) **Light drives:** They are used to transmit small powers at belt speeds up to about 10 m/s. Ex: in agricultural machine and small machine tools.
- b) **Medium drives:** They are used to transmit medium powers at belt speeds between 10 m/s and 22 m/s. Ex: in machine tools
- c) **Heavy drives:** They are used to transmit large powers at belt speeds above 22 m/s. Ex: in compressor and generators.

2. According to the shape of cross section of belt drives

- a) **Flat belt:** The cross section of the belt is like rectangular shape. They are used to transmit medium power where distance between pulleys is medium.

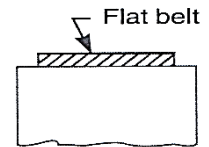

- b) **V-belt:** The cross section of the belt is like V-shape. They are used to transmit medium power where pulleys are very near to each other.

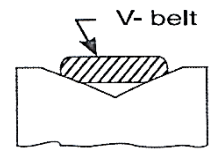

- c) **Rope:** The cross section of the belt is like circular shape. They are used to transmit large power where pulleys are far to each other.

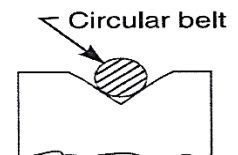

3. According to the construction and working

- a) **Open belt drive:** It is used when shafts are arranged in parallel and rotating in the same direction. The tension is more in the lower side (tight side) and less in the upper side (slack side).

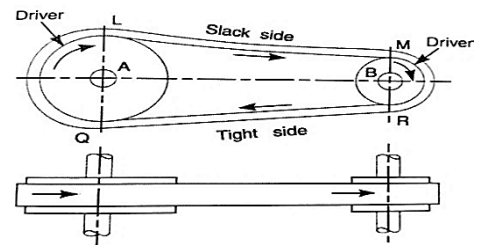

- b) **Crossed belt drive:** It is used when shafts are arranged in parallel and rotating in opposite direction.

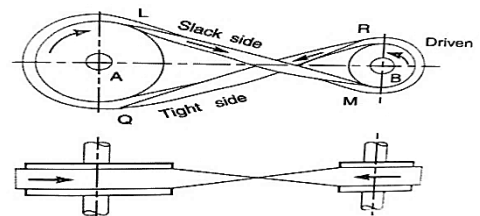

- c) **Belt drive with idler pulleys:** Idler pulleys are used to increase the contact angle on the smaller pulleys. It is used to obtain high velocity ratios.

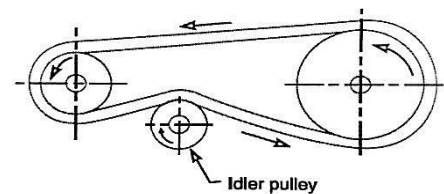

- d) **Compound belt drive:** It is used to increase or decrease the driven shaft speed.

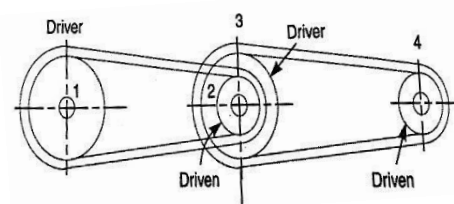

- e) **Stepped or cone pulley drive:** It is used to change the speed of the driven shaft when driving shaft runs at constant speed.

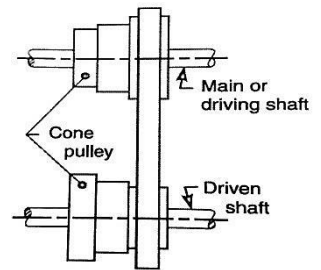

- f) **Loose and Fast pulley drive:** They put on the driven shaft to stop it whenever it is required.

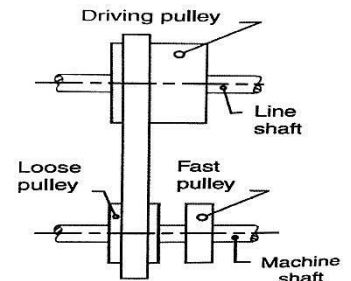

❖ **Velocity ratio of belt drives:**

- **Velocity ratio:** Speed of the driven to the driver. $\frac{N_2}{N_1} = \frac{d_1}{d_2}$

- When the thickness (t) of the belt is considered: **Velocity ratio:** $\frac{N_2}{N_1} = \frac{d_1 + t}{d_2 + t}$

d_1 =diameter of the driver

d_2 =diameter of the driven

N_1 =speed of the driver

N_2 =speed of the driven

- **Velocity ratio of a compound belt:** $\frac{\text{Speed of the last driven}}{\text{Speed of the first driver}} = \frac{\text{Product of the diameters on the drivers}}{\text{Product of the diameters on the driven}}$

$$\frac{N_4}{N_1} = \frac{d_1 \times d_2}{d_2 \times d_4}$$

- ❖ **Slip of belt:** The pulley moves without carrying belt with it because the frictional grip between belt and pulley is insufficient. It is considered in percentages. If the percentage of slip is "s", then

$$\text{Velocity ratio: } \frac{N_2}{N_1} = d_1/d_2(1 - (s/100))$$

- ❖ **Power transmitted by a belt:**

$$P = (T_1 - T_2) \cdot v \quad \text{Watt}$$

T_1 = Tension in the tight side of the belt

T_2 = Tension in the slack side of the belt

v = Velocity of the belt in m/s

- ❖ **Materials used for Belts:** Leather, Fabric (Cotton), Rubber fabric combination, Balata fabric combination

4.8 Wire Ropes

- They are used to transmit power from one pulley to another when the distance between pulleys is long (up to 150m apart)
- They are used in elevators, mine hoists, cranes, conveyors, handling devices and suspension bridges
- They are made from cold drawn wires in order to have high strength and durability of the rope.
- They are made from wrought iron, cast steel and alloy steel.
- The core made from jute, asbestos or a wire of softer steel.

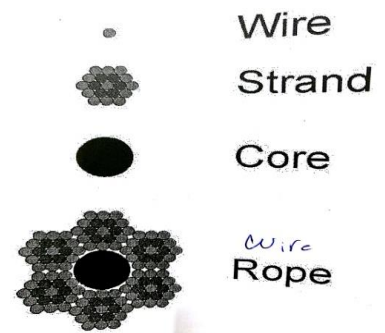

❖ **Advantages of wire ropes**

1. Withstand shock loads
2. Have more durable
3. Have silent operation
4. Have high efficiency
5. Have more reliable

❖ **Designation of wire ropes**

Standard designation (No. of strand × No. of wire)	Application
6×7 rope	It is used as rope in mines, tramways and power transmission.
6×19 rope	It is used in mine hoists, quarries, cranes, dredges, elevators, tram ways etc.
6×37 rope	It is used in steel mill ladles, cranes and high speed elevators.
8×19 rope	It is used in hoisting rope.

❖ **Procedure for designing a wire rope**

1. Selection of rope from the table (Example: 6×7)
2. Find the design load
3. Find the rope diameter
4. Find the wire diameter and rope area
5. Find the various stresses acting in the rope
6. Find the effective loads on the rope during normal working, during starting and during acceleration of the load.
7. Find the actual factor of safety (FOS) and compare with the factor assumed initially. If the actual factor of safety is within permissible limits, then the design is safe.

❖ **Failure of wire ropes:** It is due to fatigue adhesive and wear.

4.9 Breaks

- It is a device used to bring a moving system to rest, to slow its speed, or to control its speed.
- The function of a brake is to turn mechanical energy into heat.

❖ **Types of breaks**

1. Hydraulic breaks
2. Electric breaks
3. Mechanical breaks
 - Type of mechanical brakes according to the direction of action force:
 - a) **Radial brakes:** The force acting on the brake drum is in radial direction. They are divided into external brakes and internal brakes.
 - b) **Axial brakes:** The force acting on the brake drum is in axial direction. They are divided into disc brakes and cone brakes.
 - The hydraulic and electric brakes cannot bring the system to rest, and they are used where large amounts of energy are to be transformed.

❖ **Characteristics of brake materials**

1. Have high coefficient of friction
2. Have low wear rate
3. Have high heat resistance
4. Have high heat dissipation capacity
5. Have low coefficient of thermal expansion
6. Have enough mechanical strength
7. Not affected by moisture and oil

❖ Single block or shoe brake

- It consists of a block or shoe which is pressed against the wheel by a force applied to one end and other end is fixed.
- The block is made of a softer material than the rim of a wheel.
- It is used on railway trains and tram cars.
- The friction between the block and the wheel causes a tangential braking force, which delays the motion of the wheel.
- **Self-energizing brakes:** The frictional force helps to apply the brake.
- **Self-locking brake:** The frictional force is great enough to apply the brake with no external force.

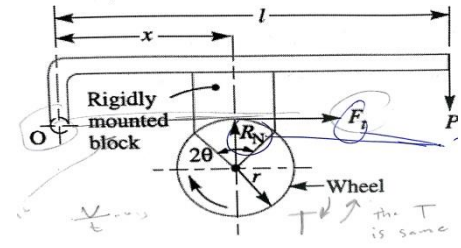

❖ Pivoted block or shoe brake

- It consists of a pivoted block or shoe which is pressed against the wheel by a force applied to one end and other end is fixed.
- The angle of contact is greater than 60° , then the pressure of contact between the block and wheel is less at the ends than at the center.

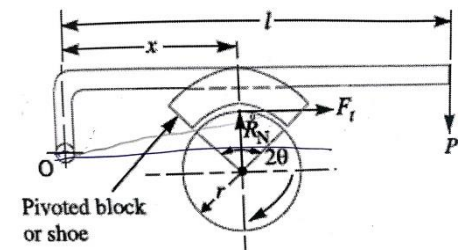

❖ Double block or shoe brake

- It consists of two blocks or shoes applied at opposite ends of the wheel.
- It is used to overcome bending of the shaft that produced in the single block brake caused additional load is applied on the shaft bearings due to normal force (R_N).
- It is used in electric cranes.

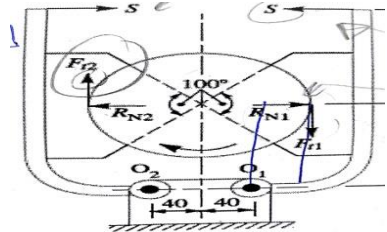

4.10 Clutches

- They are a machine member used to connect a driving shaft to a driven shaft so that the driven shaft may be started or stopped without stopping the driving shaft (engine).
- They are used in automobiles.

❖ Types of clutches

1. **Positive clutches:** They are used when a positive drive is required.

a) **Positive jaw clutch:** It allows one shaft to drive another through a direct contact of interlocking jaws.

• Types of friction clutches

- Square jaw clutch:** It is used where engagement and disengagement in motion is not necessary. It transmits power in either direction of rotation.
- Spiral jaw clutch:** It is used where engagement and disengagement in motion is necessary. It transmits power in one direction only.

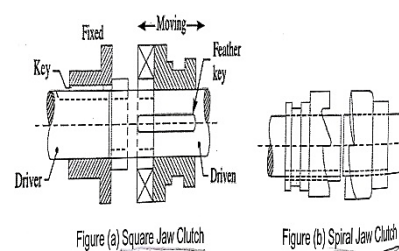

b) Friction clutches: They are used to transmit power of shafts and machines which must be started and stopped frequently. In automobiles, friction clutch is used to connect the engine to the drive shaft.

- **Characteristics of brake materials**

- i. Have high coefficient of friction
- ii. have high heat conductivity
- iii. Have high heat resistance
- iv. Not affected by moisture and oil

- **Types of friction clutches**

1. **Disc or plate clutches**

- a) **Single disc or plate clutch:** It is a dry clutch. It is used in applications where large space is available, such as trucks and cars.

- b) **Multiple disc or plate clutch:** It is a wet clutches. It is used in applications where small space is available, such as scooter and motorbike.

- **Dry and wet clutches**

- i. Dry clutch has a higher coefficient of fraction than wet clutch.
- ii. Dry clutch has a higher torque capacity than wet clutches.
- iii. Heat dissipation is more difficult in dry clutch than wet clutch.
- iv. Rate of wear is less in wet clutch than dry clutch.

2. **Cone clutches:** They was used in automobiles, but now a day it has been replaced by the disc clutch.

3. **Centrifugal clutches:** It uses a centrifugal force to connect driving shaft to the driven shaft. It works more at higher speeds. It is used in lawn mowers, chainsaws, mini bikes, and boats.

CHAPTER 5

CHAPTER 5

Thermodynamics

5.1 Thermodynamics 1

- It is the science of energy. It is the study of energy.
- **Mass (m):** The amount of material present in body. SI unit **Kg**
- **Weight (W):** the force produced when the mass of body is accelerated by gravitational acceleration. SI unit **N or Kg.m/s²**. The mass remain constant even if gravitational acceleration changes.
- **Specific volume(v):** It is the Volume per unit mass, SI unit **m³/kg**
- **Density (P):** It is the mass per unit volume, SI unit **kg/m³**
- **Specific Gravity (S.G):** Compared density of substance to the density water at standard temperature (**1 g/cm³**).
- **Temperature (T):** It is a measure of degree of hotness and coldness of the substance. Absolute temperature scale has only positive values.

Celsius (C)	Fahrenheit (F)	Kelvin (K)	Rankine (R)
<ul style="list-style-type: none"> • scales has 100 units • Freezing point of water is 0°C • Boiling point of water is 100°C • Eq: °C = (°F - 32)(5/9) 	<ul style="list-style-type: none"> • Scales has 180 units • Freezing point of water is 0 °F • Boiling point of water is 212°F • Eq: °F = 32+(9/5)°C 	<ul style="list-style-type: none"> • The absolute temperature scale that corresponds to Celsius scale. • Eq: °K = °C+273 	<ul style="list-style-type: none"> • The absolute temperature scale that corresponds to Fahrenheit scale. • Eq: °R = °F+273

- **Pressure (P):** it is the force per unit area. SI unit **N/m² or Pa**. The pressure is measured relative to perfect vacuum called **absolute pressure**. The pressure is measured relative to atmospheric called **gauge pressure**, and it will be zero when open to the atmosphere. A perfect vacuum if absolute pressure is zero.

$$\text{Eq: } P_{\text{abs}} = P_{\text{atm}} + P_{\text{gauge}}$$

$$P_{\text{abs}} = P_{\text{atm}} + P_{\text{vac}}$$

- **Energy (E):** the capacity for doing work.
 - a) **Total Energy (E):** sum of kinetic, potential, electrical, magnetic, chemical and nuclear energies.
 - b) **Potential Energy (PE):** the energy produced by the body during its position.
 - c) **Kinetic Energy (KE):** the energy produced by the body during its motion.
 - d) **Microscopic Energy:** The form of energy related to molecular structure of a system.
 - e) **Internal Energy (U):** The sum of all microscopic forms of energy. It represents the microscopic energy of a non-flowing fluid, but **enthalpy (h)** represents the microscopic energy of a flowing fluid.
 - i. **Sensible energy or heat:** The internal energy associated with the sum of kinetic and potential energy of the molecules.
 - ii. **Latent energy or heat:** The internal energy associated with the phase of a system.
 - iii. **Chemical or bond Energy:** The internal energy associated with the atomic bonds in a molecule.
 - iv. **Nuclear Energy:** The internal energy associated with the nucleus of the atom itself.

❖ Thermodynamic System and Surrounding

- **System** is a quantity of matter in space.
- **Surrounding** is everything external to the system.
- **Boundary** is separated the system and surrounding.
- System and its surrounding together make a universe.

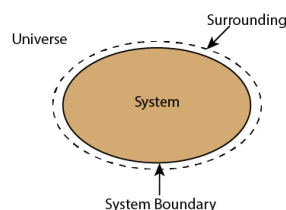

❖ Types of thermodynamic systems:

- **Isolated system:** neither energy (work or heat) nor mass transfer with its surrounding.
- **Closed system:** No mass transfer, but have energy transfer with its surrounding.
- **Open system:** Both energy and mass transfer with its surrounding.

- ❖ **Energy interactions:** closed system and its surrounding can interact in two ways:
 1. **Work transfer:** because changes in properties.
 2. **Heat transfer:** because of temperature difference
- ❖ **Thermodynamic Equilibrium:** state of rest or balanced.
 - **Types of Equilibrium:**
 - a) **Mechanical equilibrium:** There is no pressure difference.
 - b) **Thermal equilibrium:** There is no temperature difference.
 - c) **Chemical equilibrium:** There is no chemical reactions occur.
 - d) **Thermodynamic equilibrium:** If all three equilibriums are present.
- ❖ **Thermodynamic Process:** The path of states when the system passes.
 - **Cycle process:** system and surrounding return to their original condition in the final process.
 - **Reversible process:** system and surrounding return to their original condition when stop the process.
 - **Irreversible process:** system and surrounding can't return to their original condition.
- ❖ **Laws of thermodynamics:**
 - **First Law of thermodynamic:** Energy can't be created nor destroyed, but it can convert from one form to another.
 - **Second Law of thermodynamics:** the total entropy of an isolated system always increases over time, or remains constant. Or if no energy enters or leaves the system (isolated system), the potential energy of the state will always be less than that of the initial state.
 - **Zeroth Law of thermodynamics:** if two systems, *A* and *B*, are in thermal equilibrium with a third system, *C*, then *A* and *B* are in thermal equilibrium with each other.

❖ **Heat engines:** the device that converts heat into work.

- **How heat engine work:**
 1. Receives heat from a source at higher temperature.
 2. Converts a part of heat into work.
 3. Reject other part of heat to balance at lower temperature.
 4. Continues to repeat the same cycle.

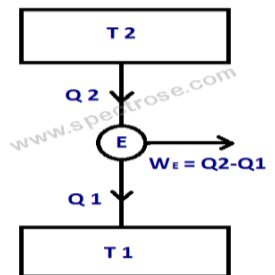

- Petrol engine, Diesel engine, Steam power plant, etc **are forms of heat engines.**
- **Thermal efficiency of heat engine:** it is the measuring of performance of heat engine.

$$\eta_{th} = \frac{\text{Net Workdone}}{\text{Heat Supplied}} = \frac{W_{net}}{Q_H} = \frac{Q_H - Q_L}{Q_H} = 1 - \left[\frac{Q_L}{Q_H} \right]$$

5.2 Thermodynamics 2

❖ **Ideal and Real Gas:**

1. **Ideal gas:** it is one which
 - Attraction between molecules is zero.
 - The size of molecules is zero.
 - Doesn't change its phase during thermodynamic process.
 - Obey all gas laws.
2. **Real gas:** Opposite to ideal gas.

❖ **Gas Laws:**

- **Boyles Law:** Pressure is inversely proportional to Volume when Temperature is constant. $Pv=C$
- **Charles Law:** Volume is directly proportional to temperature when pressure is constant. $\frac{V}{T} = C$

- **Guy Lussac's Law:** Pressure is directly proportional to temperature when volume is constant.

$$\frac{P}{T} = C$$

- ❖ **Avogadro's Law:** the volume of 1 kg, mole of all gases at normal temperature & pressure is the same and it is equal to 22.4 m³.

$$n = \frac{m}{M} \quad m=\text{mass}; M=\text{molecular weight}; n=\text{number of moles}$$

- ❖ **Idea gas equation of state:**

$$PV=mRT \quad \text{Universal Gas Constant (R}_u\text{): } 8.314 \text{ KJ/Kmol.}^\circ\text{K}$$

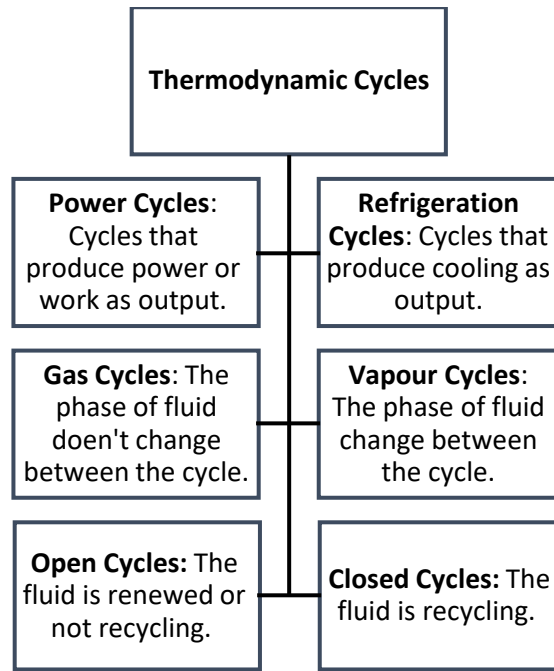

Classification of Air Cycle

- ❖ **Ideal Cycles and Actual Engines:**

Ideal Cycle: <ul style="list-style-type: none"> • Processes are Totally Reversible. • Friction, viscous, etc. are absent. • Impossible to achieve in real. • Cycle with maximum possible Efficiency. 	CARNOT CYCLE			
Ideal Cycle: <ul style="list-style-type: none"> • Processes are Internally Reversible. • Friction, viscous, etc. are absent. • Impossible to achieve in real. 	OTTO Cycle	Diesel Cycle	Brayton Cycle	Rankine Cycle
Actual Heat Engines: <ul style="list-style-type: none"> • Processes are Irreversible. • Friction, viscous, etc. are present. • Possible to achieve in real. 	Petrol Engine	Diesel Engine	Gas Turbines	Steam Turbines

- ❖ **Reciprocating Engines:** petrol and diesel engines are reciprocating engines.

- **Terminology of reciprocating engine:**

- Bore of Cylinder (D):** Inner diameter of cylinder.
- Top Dead Center (T.D.C):** The end position of piston at the top of the cylinder
- Bottom Dead Center (B.D.C):** The end position of piston at the bottom of cylinder.

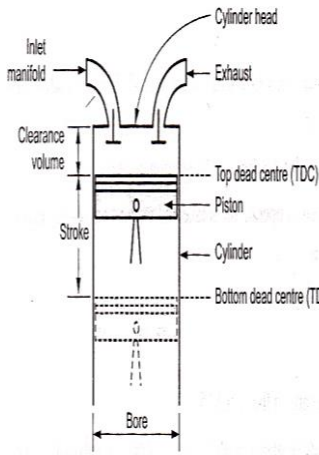

- **Stroke length (L):** the distance between TDC and BDC
- **Swept or Stroke volume (V_s):** the volume between TDC and BDC. $V_s = \frac{\pi}{4} D^2 L$
- **Clearance Volume (V_c):** the space between TDC cylinder head. $V_c = \% V_s$
- **Volume of cylinder (V):** $V = V_c + V_s$
- **Compression ratio (r):** the ratio of cylinder volume to the clearance volume.

$$r = \frac{V}{V_c}$$
- **Mean Effective Pressure (mep):** the ratio of net workdone to stroke volume. $mep = \frac{\text{net work done}}{\text{stroke volume}}$

- **Internal Combustion engines:** combustion takes place inside a cylinder.
 1. **Spark Ignition Engine (S.I. Engine)**
 - Petrol is used as the fuel
 - Air and fuel (petrol) enter to cylinder and then compressed.
 2. **Compression Ignition Engines (C.I. Engines)**
 - Diesel is used as the fuel
 - Only air enters to cylinder and then compressed.
- **4 stroke petrol engine:** the stroke used in a 4 stroke engine are:
 1. **Suction or intake stroke:** Inlet valve is opening, Air and petrol enter, outlet valve is closed.
 2. **Compression Stroke:** Both valves are closed, Both air and petrol are compressed.
 3. **Power or Expansion Stroke:** Air and Petrol are Combustion, piston move down cause expansion.
 4. **Exhaust Stroke:** Outlet valve open, Combustion gases go out after expansion, Inlet valve closed.

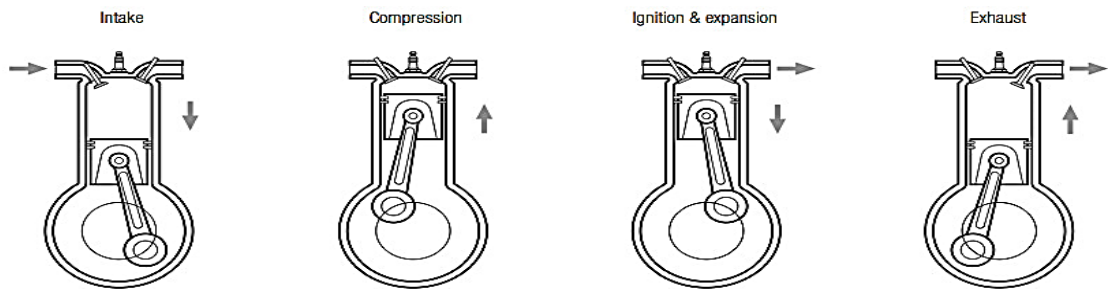

❖ **Carnot cycle:** it is a reversible thermodynamic cycle established by Sadi Carnot.

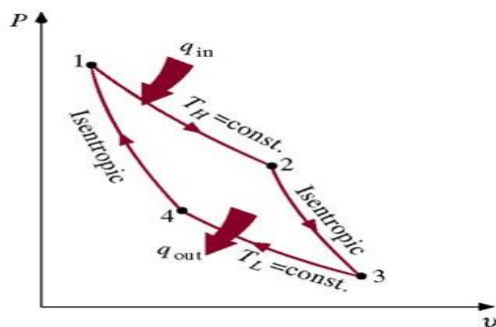

PV Diagram of Carnot cycle

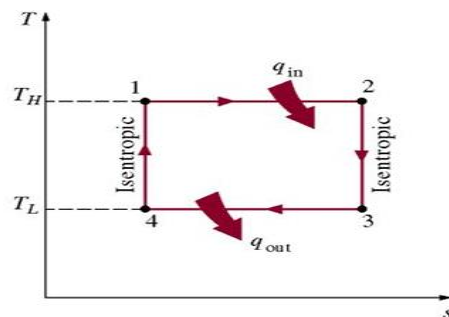

TS Diagram of Carnot cycle

State points	Processes	P	V	T	S
1-2	Isothermal heat addition (heat is added at constant T)	Decreases	Increases	Constant	Increases
2-3	Ientropic expansion (always com. and exp. are Ientropic) Ientropic means the heat transfer & change in entropy are zero	Decreases	Increases	Decreases	Constant
3-4	Isothermal heat rejection (heat is rejected at constant T)	Increases	Decreases	Constant	Decreases
4-1	Ientropic expansion	Increases	Decreases	Increases	Constant

Property changes

- Thermal Efficiency of a Carnot cycle: $\eta_{\text{Carnot}} = \frac{W_{\text{net}}}{Q_H} = 1 - \left[\frac{T_L}{T_H} \right]$
 - If $\eta_{\text{Carnot}} > \eta_{\text{Inventor}} \Rightarrow$ Claim is possible
 - If $\eta_{\text{Carnot}} \leq \eta_{\text{Inventor}} \Rightarrow$ Claim is not possible

❖ **OTTO Cycle:** it is also called Constant Volume cycle or Petrol Engine Cycle. It is the ideal cycle for S.I. Engines.

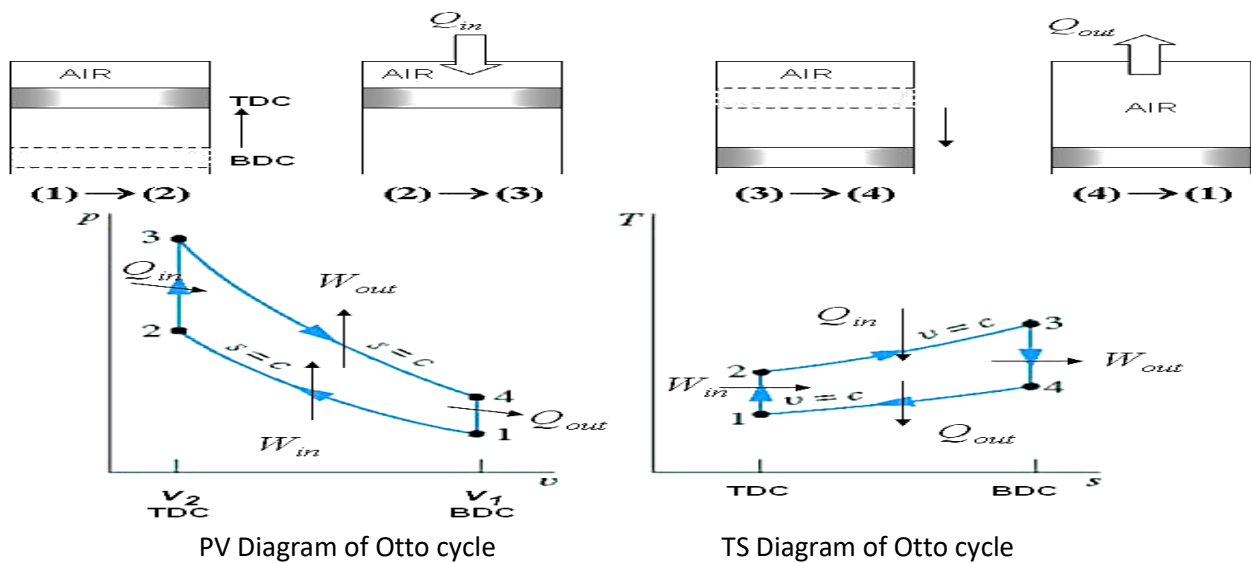

PV Diagram of Otto cycle

TS Diagram of Otto cycle

State points	Processes	P	V	T	S
1-2	Ientropic compression	Increases	Decreases	Increases	Constant
2-3	Isochoric heat addition (v=constant)	Increases	Constant	Increases	Increases
3-4	Ientropic expansion	Decreases	Increases	Decreases	Constant
4-1	Isochoric heat Rejection (v=constant)	Decreases	Constant	Decreases	Decreases

Property changes

- Thermal Efficiency of a OTTO cycle: $\eta_{\text{th}} = \frac{W_{\text{net}}}{Q_{in}} = 1 - \left[\frac{Q_{out}}{Q_{in}} \right]$
 $\eta_{\text{otto}} = 1 - \left[\frac{1}{r^{\gamma-1}} \right]$ or $1 - \left[\frac{T_4}{T_3} \right]$, r=compression ratio= (v_1/v_2) , γ =specific heat ratio

❖ **Diesel Cycle:** It is the ideal cycle for C.I. Engines. It is for slow speed compression. The diesel cycle is similar to the Otto cycle with only one change: heat is added at constant pressure in diesel and at constant volume in Otto.

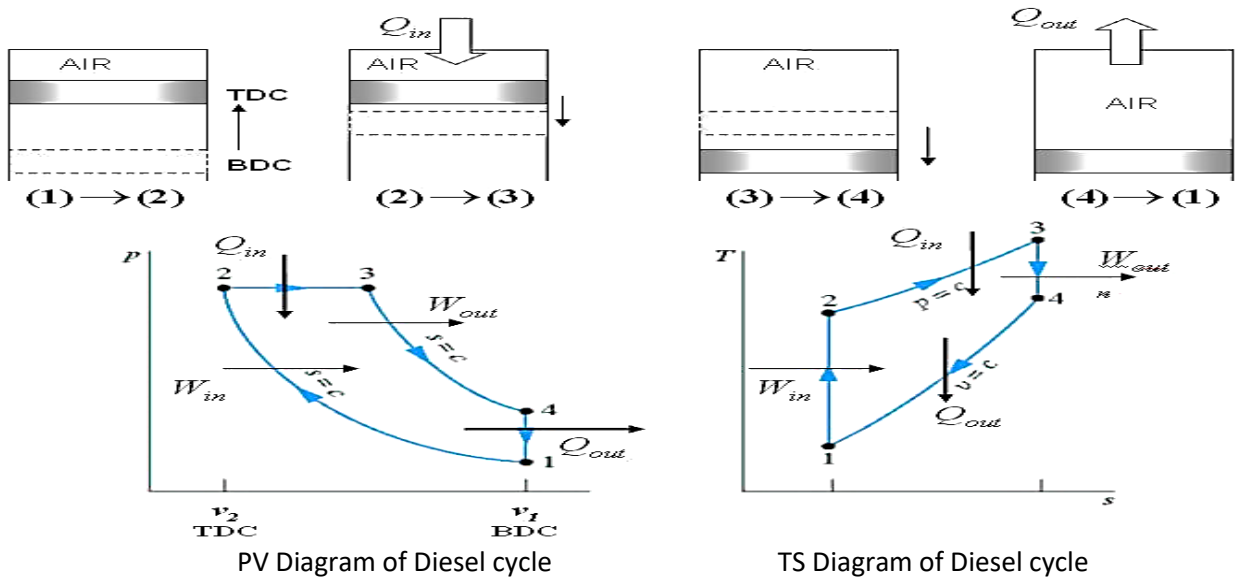

State points	Processes	P	V	T	S
1-2	Isentropic compression	Increases	Decreases	Increases	Constant
2-3	Isobaric heat addition (p=constant)	Constant	Increases	Increases	Increases
3-4	Isentropic expansion	Decreases	Increases	Decreases	Constant
4-1	Isochoric heat Rejection (v=constant)	Decreases	Constant	Decreases	Decreases

Property changes

- Thermal Efficiency of a Diesel cycle: $\eta_{th} = \frac{W_{net}}{Q_{in}} = 1 - \left[\frac{Q_{out}}{Q_{in}} \right]$
 $\eta_{Diesel} = 1 - \left[\frac{1}{r^{\gamma-1}} \right] \left[\frac{r^{\gamma}-1}{\gamma(P-1)} \right]$, r =compression ratio= (v_1/v_2) , γ =specific heat ratio, $(P-1)=0.06(\gamma-1)$
 Cut off ratio= v_3/v_2 Cut off Volume= v_3-v_2

❖ **Brayton Cycle:** It is the ideal cycle for Gas Turbine. Heat is added and rejected at constant pressure. It is used in aircraft propulsion and electric power generation.

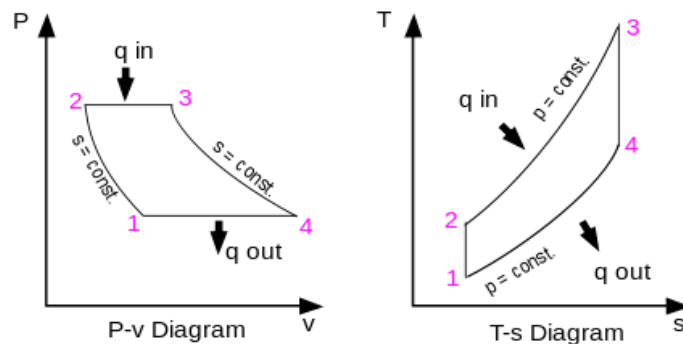

State points	Processes	P	V	T	S
1-2	Isentropic compression	Increases	Decreases	Increases	Constant
2-3	Isobaric heat addition (p=constant)	Constant	Increases	Increases	Increases
3-4	Isentropic expansion	Decreases	Increases	Decreases	Constant
4-1	Isobaric heat Rejection (p=constant)	Constant	Decreases	Decreases	Decreases

Property changes

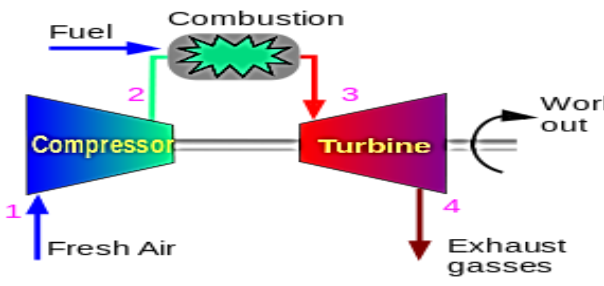
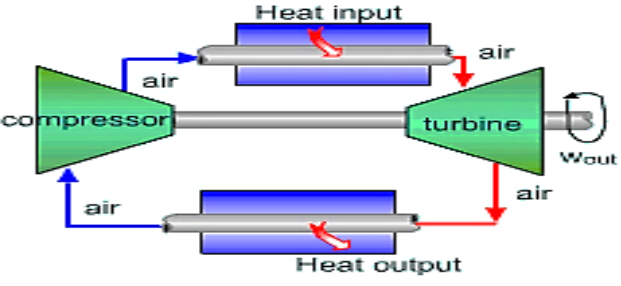
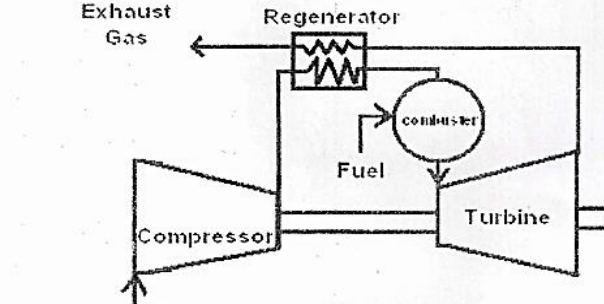
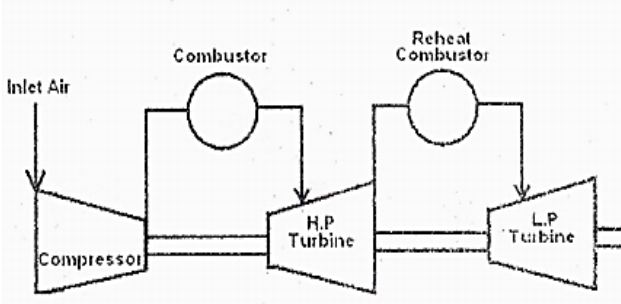
Open Brayton cycle (Open cycle gas turbine)	Closed Brayton cycle (Closed cycle gas turbine)
 <p>Working:</p> <ol style="list-style-type: none"> 1. A fresh air enters into a compressor and after compression passes to a combustion chamber. 2. Fuel and the higher pressure air are burn in combustion chamber at constant pressure and produce high temperature gases. 3. The high temperature gases sent to turbine and expand to produce power. 4. The exhaust gases leave the turbine to atmosphere at lower temperature and pressure. 	 <p>Working:</p> <ol style="list-style-type: none"> 1. A fresh air enters into a compressor and after compression passes to a combustion chamber. 2. Fuel and the higher pressure air are burn in combustion chamber at constant pressure and produce high temperature gases. 3. The high temperature gases sent to turbine and expand to produce power. 4. The gases leave the turbine to heat exchanger. It reduces temperature by cooling and sent to compressor to repeat the cycle.
Brayton cycle with Regenerator	Brayton cycle with Reheat
 <p>Working:</p> <ol style="list-style-type: none"> 1. A fresh air enters into a compressor and after compression passes to regenerator to use exhaust heat to increase temperature of air and then passes to a combustion chamber. 2. Fuel and the higher pressure air are burn in combustion chamber at constant pressure and produce high temperature gases. 3. The high temperature gases sent to turbine and expand to produce power. 4. The exhaust gases leave the turbine to atmosphere at lower temperature and pressure. 	 <p>Working:</p> <ol style="list-style-type: none"> 1. A fresh air enters into a compressor and after compression passes to a combustion chamber. 2. Fuel and the higher pressure air are burn in combustion chamber at constant pressure and produce high temperature gases. 3. The high temperature gases sent to LP turbine and partial expand then passes to another combustion chamber to reheat. 4. The high temperature gases return to HP turbine to produce power. 5. The exhaust gases leave the turbine to atmosphere at lower temperature and pressure.

- Thermal Efficiency of a Brayton cycle: $\eta_{th} = \frac{W_{net}}{Q_{in}} = 1 - \left[\frac{Q_{out}}{Q_{in}} \right]$

$$\eta_{Brayton} = 1 - \left[\frac{T_1}{T_2} \right] = 1 - \left[\frac{p_1}{p_2} \right]^{\frac{\gamma-1}{\gamma}} = 1 - \frac{1}{[r_p]^{\frac{\gamma-1}{\gamma}}}, \gamma = \text{specific heat ratio, } r_p = \text{pressure ratio}$$

Applications of Brayton Cycle	Advantages of Brayton Cycle	Disadvantages of Brayton Cycle
<ol style="list-style-type: none"> 1. Aviation 2. Power generation 3. Oil and Gas industry 4. Marine propulsion 	<ol style="list-style-type: none"> 1. Light weight 2. No cooling water required 3. Low installation cost 4. Quick starting 	<ol style="list-style-type: none"> 1. Not self-starting 2. Low efficiency 3. Non irreversibility 4. Higher rotor speeds

❖ **Rankine Cycle:** It is the ideal cycle for Steam Turbine. Heat is added and rejected at constant pressure.

State points	Processes	P	V	T	S
1-2	Isentropic compression(in pump)	Increases	Decreases	Increases	Constant
2-3	Isobaric heat addition (p=constant) in boiler	Constant	Increases	Increases	Increases
3-4	Isentropic expansion (in turbine)	Decreases	Increases	Decreases	Constant
4-1	Isobaric heat Rejection (p=constant) in condenser	Constant	Decreases	Decreases	Decreases

Property changes

• **Principle components of Rankine cycle:**

1. **Pump:** It is a device used to convert low pressure liquid to high pressure liquid.
2. **Boiler:** It is a device used to convert liquid to steam by heating.
3. **Turbine:** It is a device used to convert high pressure steam to low pressure steam.
4. **Condenser:** It is a device used to convert steam to liquid by condensing.

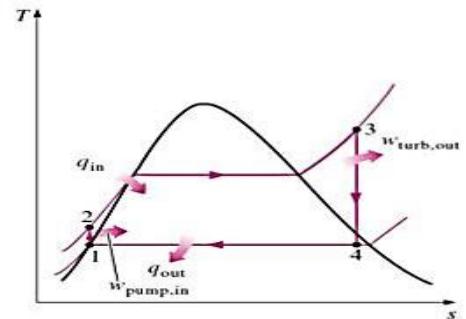
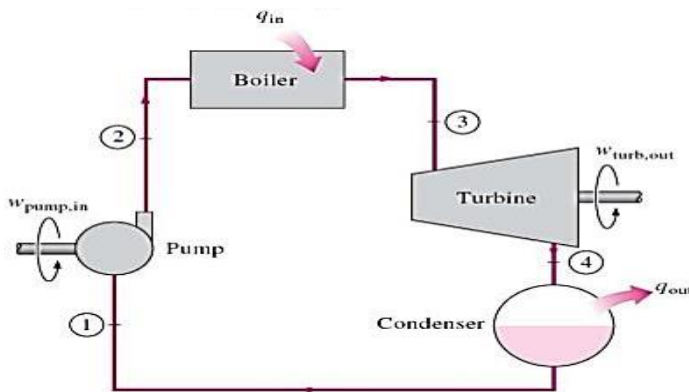

Working:

Pump (process 1-2): Pump pressured the liquid water which coming from the condenser to going back to the boiler. $W_{pump, in} = h_2 - h_1$

Boiler (process 2-3): Liquid water enters the boiler and it heated to convert to steam. $Q_{in} = h_3 - h_2$

Turbine (process 3-4): Steam from the boiler, which has high temperature and pressure, expands through the turbine to produce work and then is discharged to the condenser with low pressure. $W_{turbine, out} = h_3 - h_4$

Condenser (process 4-1): Steam from the turbine converts to liquid water in the condenser. $Q_{out} = h_4 - h_1$

- **Methods to increase the efficiency of the Rankine cycle:** Efficiency of Rankine Cycle is increased by increasing the Boiler temperature or decreasing the condenser temperature.

Decreasing condenser pressure	Superheating the steam	Increasing the boiler pressure
<p>When the pressure of condenser decreased, the temperature will decrease, so the efficiency of cycle will also increase.</p>	<p>Increasing the heat added to boiler without increasing pressure.</p>	<p>When the pressure of boiler increased, the temperature will increase, so the efficiency of cycle will also increase.</p>

- Thermal Efficiency of Rankine cycle: $\eta_{th} = \frac{W_{net}}{Q_{in}} = 1 - \left[\frac{Q_{out}}{Q_{in}} \right]$

$$\eta_{Rankine} = \frac{W_T - W_P}{h_3 - h_2} = 1 - \left[\frac{h_4 - h_1}{h_3 - h_2} \right]$$

- Rankine cycle with reheat:** Steam passes through the high pressure turbine to be reheated in boiler and then pass through the low pressure turbine.

$$Q_{in} = (h_3 - h_2) + (h_5 - h_4)$$

$$Q_{out} = (h_6 - h_1)$$

$$\begin{aligned} \dot{W}_{net} &= \dot{W}_{out} - \dot{W}_{in} \\ &= (\dot{W}_{LPT} + \dot{W}_{HPT}) - \dot{W}_{pump} \end{aligned}$$

$$\eta_{Rankine} = 1 - \left[\frac{h_6 - h_1}{(h_3 - h_2) + (h_5 - h_4)} \right]$$

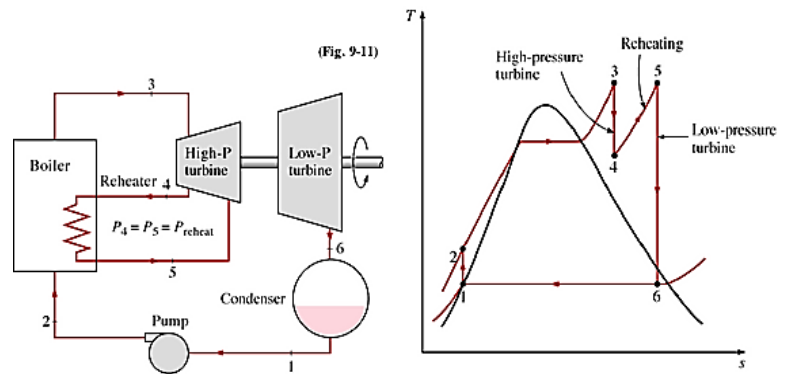

- Rankine cycle with regenerative:** the stream comes from the boiler passes into two ways, a part passes through the high pressure turbine and fed to the open feed water heater (this is path 5→6) and other part passes through the low pressure turbine to condenser.

$$Q_{in} = h_5 - h_4$$

$$Q_{out} = h_7 - h_1$$

$$\begin{aligned} \dot{W}_{net} &= \dot{W}_{out} - \dot{W}_{in} \\ &= \dot{W}_T - (\dot{W}_{pump1} + \dot{W}_{pump2}) \end{aligned}$$

$$\eta_{Rankine} = 1 - \left[\frac{h_7 - h_1}{h_5 - h_4} \right]$$

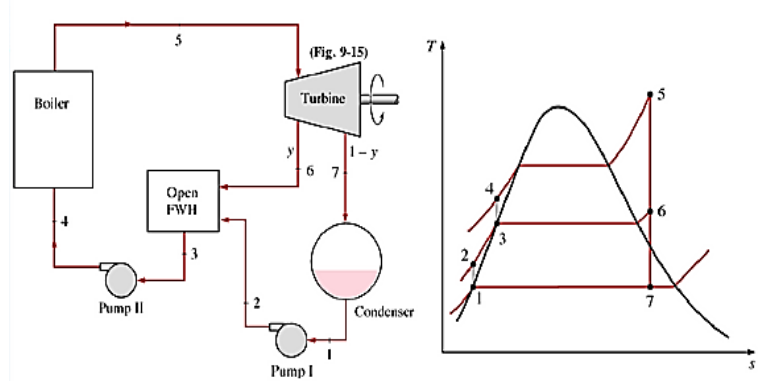

- Feed water heater:** it is heat exchanger which uses the waste heat from exhaust gases to heat the feed water before enter the boiler.

- ❖ **Combined Cycle Power Plants:** it combines a Brayton Cycle on the top and a Rankine Cycle at the bottom. The exhaust gas from gas turbine is recovered in heat recover steam generator (HRSG).

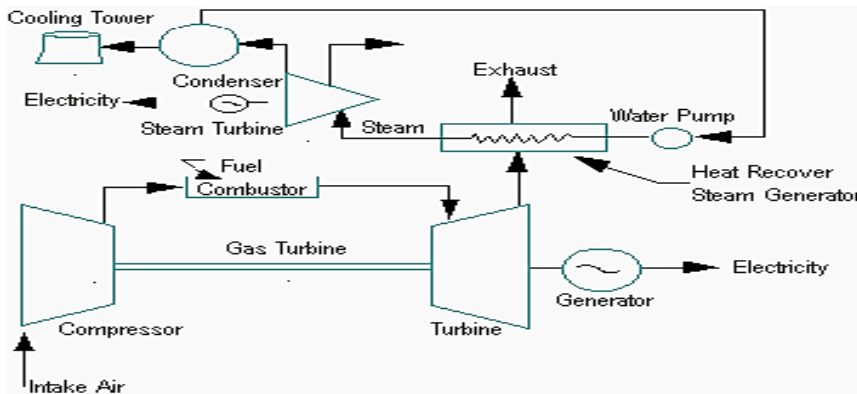

Comparison of Efficiency	
Type	Efficiency
Rankine	35
Brayton	20
Combined	45

❖ **Air Compressors:** They are a mechanical device used for increasing the pressure of air and store it in a high pressure vessel.

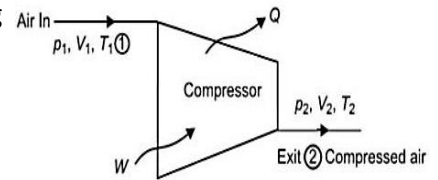

- **Applications of compressed air:**

1. Dusting/Cleaning/ Drying machines
2. Inflation of tires
3. Operating tools in factories
4. Operating brakes of buses, trucks or other heavy vehicles
5. Operation of pneumatic valves in automated processing industries
6. Air conditioning & cooling tower

- **Classifications of compressors:**

1. Based on principle of working
 - a) Positive Displacement Type
 - b) Centrifugal Type
2. Based on number of stages
 - a) Single stage: When the compressor compresses the air from atmospheric pressure to discharge pressure in a single stage. It is used to delivery pressure up to 5 bar.
 - b) Multi stage: When the compressor compresses the air from atmospheric pressure to final discharge pressure in more than one step by using more than one single stages of compressor. It is used to delivery pressure more than 5 bar.
3. Based on capacity of compressors:
 - a) Low capacity compressors, having air delivery capacity up to 0.15 m³/s
 - b) Medium capacity compressors, having air delivery capacity between 0.15 & 5 m³/s
 - c) High capacity compressors, having air delivery capacity more than 5 m³/s
4. Based on highest pressure developed:
 - a) Low pressure compressor, having maximum pressure up to 1 bar.
 - b) Medium pressure compressor, having maximum pressure from 1 to 8 bar
 - c) High pressure compressor, having maximum pressure from 8 to 10 bar.
 - d) Super high pressure compressor, having maximum pressure more 10 bar

- **Work of compression – Three Methods:** Compression of gas can be done in the following methods:

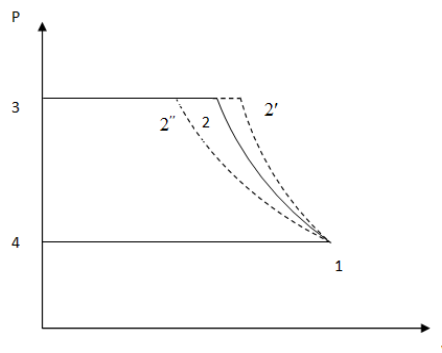

Work of compression – Three Methods

1. **Isothermal compression** (1-2["]): $PV = C$
 - If heat is added or taken away to maintain the gas at a constant temperature.
 - In practice, no compressor is isothermal ($\eta_{Iso} = 100\%$), because the temperature of a gas rises when it is compressed.
 - Isothermal compression is more efficient than adiabatic compression because no energy goes to raise the temperature of the gas; all energy input goes to raise the gas pressure.
 2. **Polytropic compression** (1-2): $PV^n = C$
 - If gas is compressed, then cooled (in an intercooler), then compressed again.
 - To make compression more efficient it needs to be as close as possible to isothermal. In practice, this is achieved by cooling the compressed gas several times during compression.
 - It is less efficient than isothermal compression but more efficient than adiabatic.
 3. **Adiabatic compression** (1-2[']): $PV^\gamma = C$
 - If no heat is added or taken away during compression.
 - In practice, no compressor is adiabatic, because some heat is always lost to surroundings.
 - It is used in a single stage of a centrifugal compressor to measure the performance of machines.
- **Various Terms & Efficiencies Used in Air-Compressor:**
 - a) **Free Air Delivery: (F.A.D.):** It is the volume flow rate of compressor expressed in m³/min as reduced to intake pressure and temperature.
 - b) **Volumetric efficiency:** It is the ratio of volume of free air delivered per the swept volume. $\eta_{Vol} = \frac{\text{Volume of free air delivery}}{\text{Swept Volume}} = \frac{V_a}{V_s}$
 - c) **Isothermal efficiency:** It is the ratio of isothermal work to the actual indicated work. $\eta_{Iso} = \frac{\text{Isothermal work}}{\text{Actual indicated work}}$, Actual indicated work: The area on P-V diagram.
 - e) **Isentropic efficiency:** It is the ratio of isentropic work of a compressor to the actual work required by compression. This term is mostly used in refrigerant compressor. $\eta_{Ise} = \frac{\text{Isentropic work}}{\text{Actual indicated work}}$
 - d) **Mechanical efficiency:** It is the ratio of indicated power of compressor to the actual shaft power of compressor. Shaft power of compressor means power required to be given to its driving shaft. $\eta_{Mech} = \frac{\text{Indicated power}}{\text{Actual shaft power}}$
 - e) **Clearance ratio:** It is the ratio of clearance volume to the total swept volume of an air compressor. It is denoted as K or C. $K = \frac{V_c}{V_s}$
 - f) **Pressure ratio:** It is the ratio of discharge pressure to suction pressure of a compressor
 - **Work of compression without clearance:**
 - i. The area under the cycle diagram gives the net work done on the compressor.
 - ii. **In case of an isothermal compression**, i.e. compression without any rise in temperature, compressor raises the pressure of air by decreasing of volume only, so work is least.
 - iii. **In case of isentropic compression**, compressor raises the pressure by decreasing of volume of air and also due to rise in temperature thus more work is required.

- iv. If some cooling is done, temperature rise will be less and also pressure rise will also be less thus lesser work will be required.

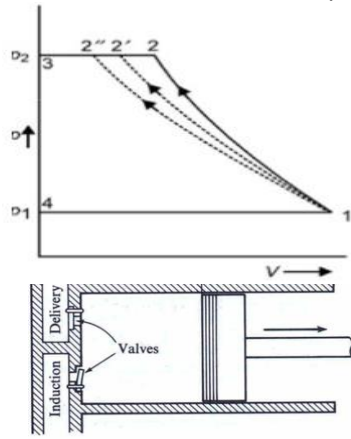

T-S diagram

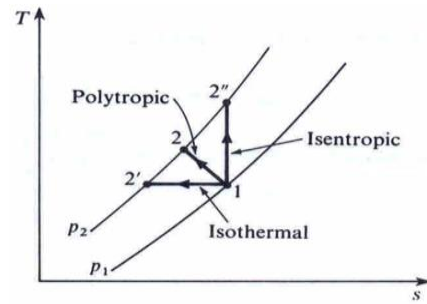

P-V diagram

• **Work of compression with clearance:**

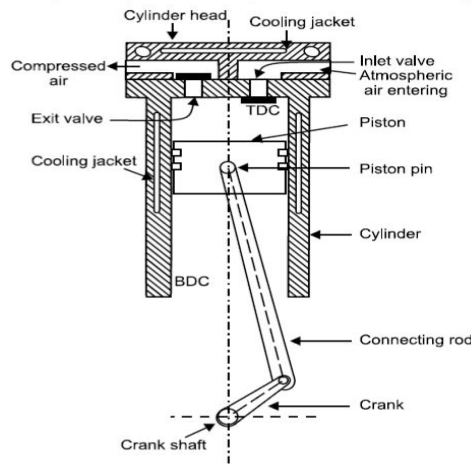

Reciprocating compressor

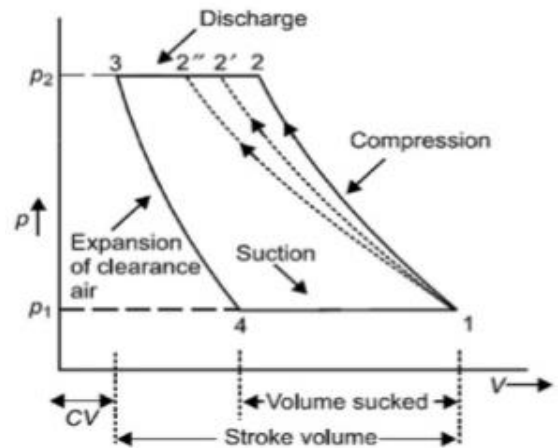

P-V diagram

Working

Compression (process 1-2): During this process, both suction and discharge valve remain closed and compressor becomes a closed system. The piston moves inside the cylinder from BDC to TDC, so pressure of air rises. The compression may happen theoretically as any of the isentropic, isothermal or polytropic processes. In actual compressor it is always a polytropic process and try to keep it as close to isothermal process as possible by external cooling. Piston work is less in case of isothermal compression.

Compressed air discharge (process 2-3): When the pressure in the cylinder reaches to a required value, discharge valve opens and compressor becomes an open system. Compressed air is discharged to compressed air tank through the discharge valve. This process ends when the piston reaches to the TDC.

Expansion of air in clearance volume (process 3-4): During this process, both suction and discharge valve are closed and compressor becomes a closed system. The piston moves down towards BDC and cylinder volume starts increasing. Due to increase in volume, pressure

decreases, but some high pressure air remains in the clearance volume which could not be discharged. This clearance volume expands air polytropically or isothermally or isentropically doing some work on piston. When pressure becomes below the outside normal air pressure, suction valve opens and expansion process ends. This process is reverse of compression process 1-2. Due to this process the effective suction of air is reduced and volumetric efficiency becomes less than 1.

Suction of air (process 4-1): After opening of suction valve, atmospheric air is absorbed in the cylinder. In this process, compressor becomes an open system. At the end of this process, the theoretical work by compressor during one cycle is given by area inside the cycle 1-2-3-4. In this way, when the piston is reciprocated continuously in the cylinder by rotating the crankshaft with the help of an electric motor, it completes one working cycle in two strokes of piston or one revolution of crankshaft.

- **Multistage Compression:**

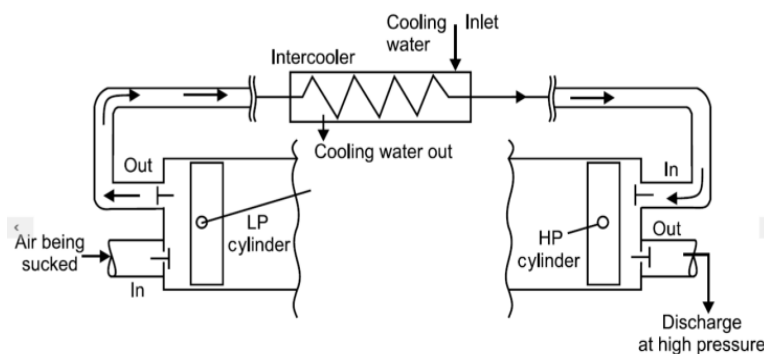

Multistage Compression

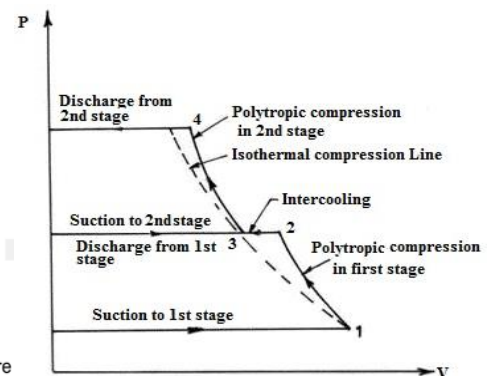

P-V diagram

- If the number of stages is increased, the compression process become nearly isothermal and the compression work decreases.
 - The pressure increased from P_2 to P_2' causes the volume reduces from $(V_1 - V_4)$ to $(V_1 - V_4')$ with increased pressure ratio from $\left(\frac{P_2}{P_1}\right)$ to $\left(\frac{P_2'}{P_1}\right)$.
 - Low Pressure Cylinder: LP cylinder compresses the air from suction pressure (P_1) to intermediate pressure (P_2).
 - High Pressure Cylinder: HP cylinder compresses the air from intermediate pressure (P_2) to discharge pressure (P_2').
- v. **Advantages of multistage compression**
- (Save Power): The air can be cooled at intermediate pressure between the stages of compression, thus decreasing the work required for next stage.
 - Multistage compressors have better mechanical balance. So lighter flywheel is required.
 - The pressure and temperature range kept within desirable limits to improved lubrication, Improved volumetric efficiency, and Reduced losses due to air leakage.
- vi. **Disadvantages**
- The multistage compressor with intercoolers is more expensive than a single stage.

❖ **Refrigeration and air conditioning:**

- **Refrigeration** is any process of heat removal to reduce and maintain the temperature in a region the temperature of the surrounding. Or the transfer of heat from lower temperature regions to higher temperature regions.
- **Refrigerators:** They are devices which produce refrigerating effect and cycles on which they operate are called refrigerator cycles.
- **Refrigerant:** The working fluids used for carrying heat away.
- **Refrigeration can be open cycle or closed cycle:**
 - 1) **In open cycle,** the refrigerant passes through the system once for refrigerating the space and is thrown away as it gets polluted.
 - 2) **In closed cycle,** the refrigerant flows inside tubes during refrigerating the space and it does not get polluted.
- **Applications of refrigeration:** It is used for preserving medicine, blood, food, etc.
- **Air conditioning:** Refrigerating a region in reference to the human comfort.
- **Applications of air conditioning:** It is used in buildings, hospitals, offices, working spaces, vehicles, trains, aero planes, etc.
- Heat pump is the device which runs exactly similar to the refrigerator but its purpose is to maintain the body at temperature higher than that of surroundings
- **Different methods for refrigeration:**
 1. **Refrigeration by evaporation:** Refrigeration effect can be done by evaporation of liquid. Examples: Cooling of water kept in (earthen pot or desert bag).
 2. **Refrigeration by ice:** In this kind of refrigeration, ice is kept in the insulated box.
 3. **Refrigeration by expansion of air:** The expansion of air is the cooling air due to reduction in its temperature.
 4. **Refrigeration by throttling process:** Throttling of gases show the reduction in temperature of gas after throttling.
 5. **Refrigeration by dry ice:** Dry ice is used in packaging of frozen foods for maintaining them at low temperature.
 6. **Refrigeration using liquid gases:** Liquid gases such as liquid nitrogen and liquid carbon dioxide are used for refrigeration in refrigerated cargo vehicles.
 7. **Vapor Refrigeration system:** Vapor refrigeration system based on vapor compression refrigeration system and vapor absorption refrigeration system.

• **Performance Parameter:**

- a) **Refrigerator's performance** is given by coefficient of performance (COP).
- b) **COP of refrigerator** is the ratio of refrigeration effect and network done upon refrigerator. $COP = \frac{Q_2}{W} = \frac{Q_2}{(Q_1 - Q_2)}$
- c) COP of refrigerator may have any magnitude i.e. less than unity or greater than unity (1).
- d) **Performance of heat pump** is also given by the parameter defined like COP but instead of calling it COP, it is called energy performance ratio (EPR)
- e) $EPR = \frac{Q_1}{W} = \frac{Q_1}{(Q_1 - Q_2)}$, $EPR = COP + 1$
- f) **EPR** will always have its magnitude greater than unity (1).

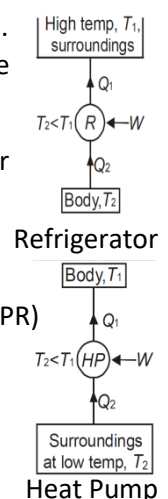

• **Unit of Refrigeration:**

- a) The unit of refrigeration called 'Ton' of refrigeration.
- b) **Ton of refrigeration** defined as a cooling power needed to freeze 1 ton (2000 lb) of 0°C (32°F) water to ice during 1 day (24 hours).
- c) **1 Ton of refrigeration** = mass of water × latent heat at 0°C from water to ice (in SI units).

$$= \frac{(1000 \times 334.5)}{24} \text{ kJ/hr} = \frac{(1000 \times 334.5)}{24 \times 3600} \text{ kJ/sec} = 3.5 \text{ kJ/sec or kW}$$

• **Carnot Refrigeration Cycle:**

- a) Carnot cycle can use for getting the refrigeration effect upon its reversal.

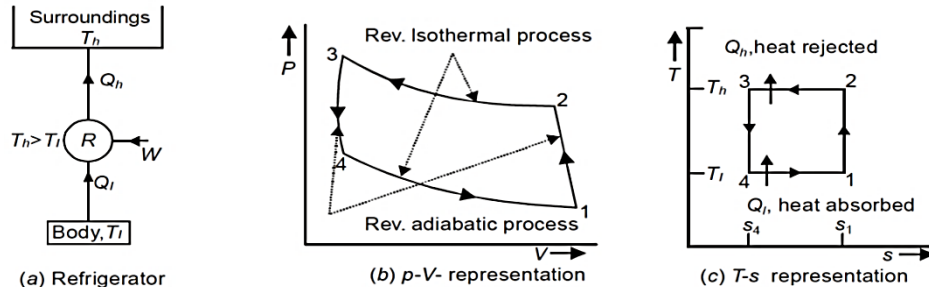

Reversed Carnot cycle for refrigeration

- b) Here, the refrigerated body is to be maintained at low temperature T_l for which heat Q_l should be removed at constant rate and rejected to surroundings at high temperature T_h . Amount of heat rejected to surroundings is Q_h while the net work done upon refrigerator is W .

State points	Processes	P	V	T	S
1-2	Reversible adiabatic compression	Increases	Decreases	Increases	Constant
2-3	Reversible isothermal heat rejection (Q_h) at temperature T_h	Increases	Decreases	Constant	Decreases
3-4	Reversible adiabatic expansion	Decreases	Increases	Decreases	Constant
4-1	Reversible isothermal heat addition (Q_l) at temperature T_l	Decreases	Increases	Constant	Increases

Property changes

c) **The coefficient of performance of Carnot refrigerator:**

- $COP_{Carnot} = \frac{Q_l}{W} = \left[\frac{T_l}{T_h} \right] - 1 = \left[\frac{T_1}{T_3} \right] - 1$
- COP of refrigerator shall be more during cold days as compared to hot days.
 $COP_{\text{cold days}} > COP_{\text{hot days}}$, because $T_{h, \text{ cold days}} < T_{h, \text{ hot days}}$

• **Air Refrigeration Cycle (Bell-Coleman cycle):**

- a) Bell-Coleman cycle based refrigerators are used in cargo ships.
- b) Refrigeration system on this cycle has a compressor, heat exchanger, expander and refrigeration unit.
- c) Bell-Coleman cycle is actually the reversed Brayton cycle.
- d) **Advantages of air refrigeration:**
 - 1) They use air as refrigerant which is cheap, nonflammable and non-toxic.
 - 2) They are light weight per ton of refrigeration compared to other refrigeration systems
 - 3) Leakage of air refrigerant may not be dangerous problem.
- e) **Disadvantages of air refrigeration:**
 - 1) They have lower COP compared to other refrigeration systems.
 - 2) Quantity of air refrigerant required is more compared to other refrigerants.

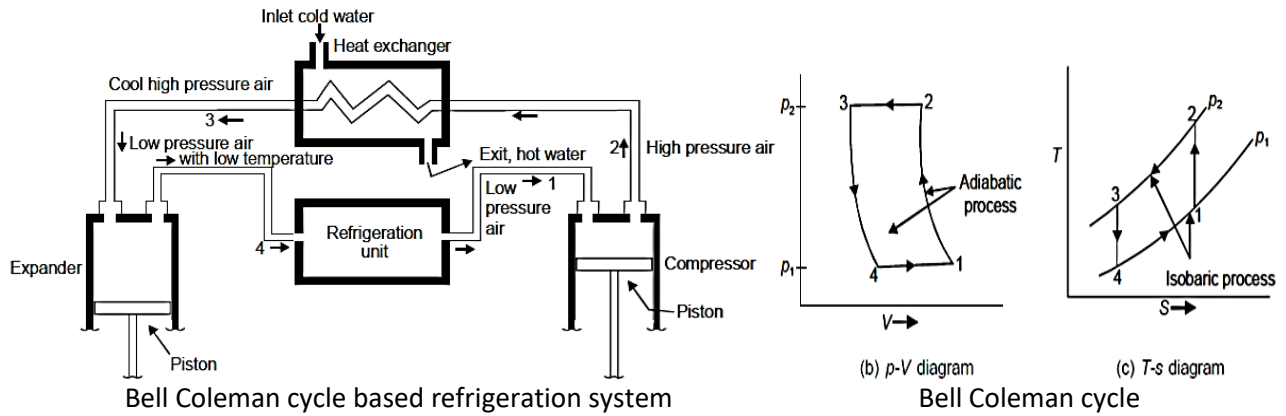

f) **Working:**

(Process 1-2): Adiabatic compression of air causing rise in its pressure and temperature inside compressor.

(Process 2-3): Isobaric heat rejection inside heat exchanger causing cooling of high pressure and high temperature air coming from compressor and making it low temperature and high pressure air. Water may be used as cooling fluid inside heat exchanger.

(Process 3-4): Adiabatic expansion inside expander causing cooling of high pressure and low temperature air coming from heat exchanger and making it low temperature and high pressure air.

(Process 4-1): Isobaric heat addition inside refrigeration unit causing heating low temperature cool air coming from expander and making it high temperature air and leaves to compressor. Thus, process (4-1) is the actual process which is giving the refrigeration effect.

State points	Processes	P	V	T	S
1-2	Adiabatic compression (in Compressor)	Increases	Decreases	Increases	Constant
2-3	Isobaric heat rejection (p =constant) in heat exchanger	Constant	Decreases	Decreases	Decreases
3-4	Adiabatic expansion (in Expander)	Decreases	Increases	Decreases	Constant
4-1	Isobaric heat addition (p =constant) in refrigeration unit	Constant	Increases	Increases	Increases

Property changes

g) **The coefficient of performance of refrigerator:**

- $COP_{Bell\ Coleman} = \frac{Desired\ effect\ (Q_{absorbed})}{Net\ work\ (W)}$, where, $W = (Q_{rejected} - Q_{absorbed})$,
 $Q_{rejected} = mC_p (T_2 - T_3)$, $Q_{absorbed} = mC_p (T_1 - T_4)$
- Since $T_2 > T_3$ so, $COP_{Bell\ Coleman} < COP_{Carnot}$

• **Vapor Compression Cycles:**

- a) It has the refrigerant (in gas/vapor) being circulated in closed circuit through compressor, condenser, throttle valve or expansion valve and evaporator.
- b) Refrigerant entering compressor is vapor in case of 'dry compression' and liquid-vapor mixture in case of 'wet compression'.
- c) The dry compressor efficiency is more than that of wet compression.
- d) Changes in kinetic energy and potential energy are negligible.

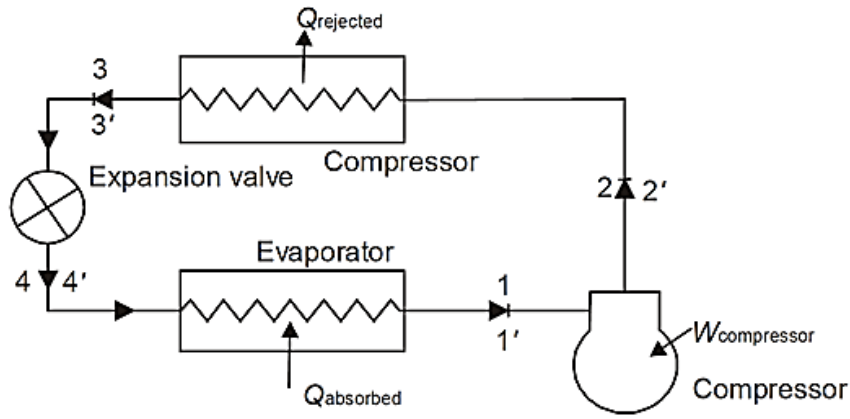

Vapor compression cycle based refrigeration system

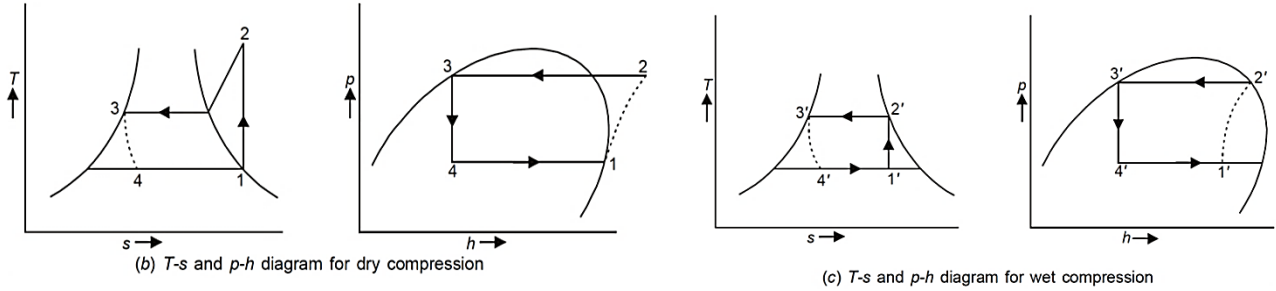

Vapor compression cycle

e) **Working**

(Process 1-2 or 1'-2'): Isentropic compression of vapor in case of 'dry compression' or liquid-vapor mixture in case of 'wet compression' causing rise in its pressure and temperature inside compressor.

(Process 2-3 or 2'-3'): Isobaric heat rejection of high pressure and temperature of dry or wet refrigerant causing converting of refrigerant into liquid form in condenser.

(Process 3-4 or 3'-4'): Isentropic expansion of liquid causing drop in its pressure and temperature inside expander.

(Process 4-1 or 4'-1'): Isobaric heat absorption of liquid causing converting of liquid into vapor in case of 'dry compression' or into liquid-vapor mixture in case of 'wet compression' in evaporator.

State points	Processes	P	h	T	S
1-2 or 1'-2'	Isentropic compression (in Compressor)	Increases	Increases	Increases	Constant
2-3 or 2'-3'	Isobaric heat rejection (p=constant) in Condenser	Constant	Decreases	Constant	Decreases
3-4 or 3'-4'	Isentropic expansion (in Expander)	Decreases	Constant	Decreases	Increases
4-1 or 4'-1'	Isobaric heat absorption (p=constant) in Evaporator	Constant	Increases	Constant	Increases

Property changes

f) **The coefficient of performance of heat pump:** $COP = \frac{\text{Desired effect}}{\text{Net work}} = \frac{Q_{\text{absorbed}}}{\text{Work input}}$

$$Q_{\text{absorbed}} = m(h_1 - h_4), \text{ in dry compression}$$

$$Q_{\text{absorbed}} = m(h_{1'} - h_{4'}), \text{ in wet compression}$$

$$W_{\text{compressor}} = m(h_2 - h_1), \text{ in dry compression}$$

$$W_{\text{compressor}} = m(h_{2'} - h_{1'}), \text{ in wet compression}$$

- **Multistage vapor compression cycle:**

- Compression for total compression ratio occurs in two stages i.e. LP compressor and HP compressor.

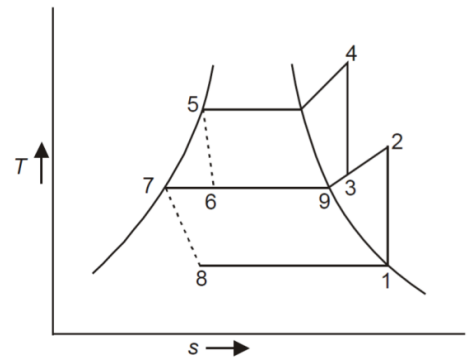
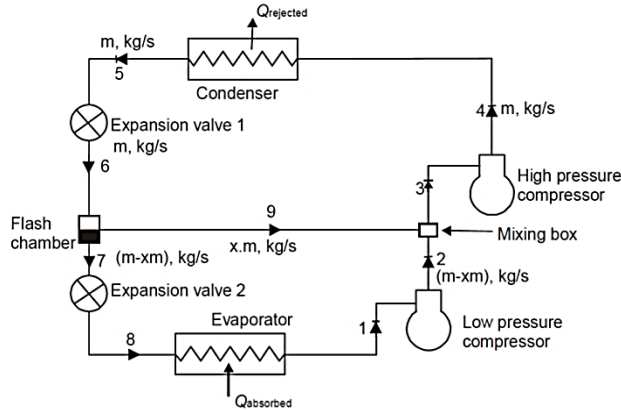

Two stage intercooled vapor compression cycle with flash chamber

T-s diagram

- Working**

(Process 1-2 adiabatic compression): Refrigerant is partly compressed in LP compressor.

(Process 2-3): Compressed refrigerant leaving compressor is cooled by mixing it with the cool vapor leaving flash chamber at state 9 and finally resulting low pressure refrigerant at low temperature.

(Process 3-4 adiabatic compression): Refrigerant is compressed in HP compressor upto state 4

(Process 4-5 Isobaric heat rejection in Condenser): High pressure refrigerant is passed through condenser where it gets condensed into liquid form.

(Process 5-6 isentropic expansion (in Expansion valve 1): High pressure liquid is passed through expansion valve 1 to yield low pressure and low temperature liquid.

(Process 6-7): Liquid vapor mixture produces inside flash chamber, so that liquid passes into next expansion valve 2 at state 7 and the vapor leaves flash chamber at state 9 for intercooling refrigerant in mixing box between state 2 and 3.

(Process 7-8 isentropic expansion (in Expansion valve 2): Liquid coming from flash chamber is passed through expansion valve 2 to reduce its pressure and temperature.

(Process 8-1 isobaric heat absorption in Evaporator): Low pressure liquid is passed through evaporator and its phase transform from liquid to vapor by absorbing heat of from the refrigerated space thereby showing cooling affect.

- **Heat pump systems:**

- Heat pump is a device used for maintaining a region or body at temperature more than that of surroundings.

- b) Heat pump is working similar to refrigerator with only different that the object of heat pump maintains temperature more than surroundings but the object of refrigerator maintains temperature less than surroundings temperature.
- c) Heat pump systems can be based upon vapor compression cycle, absorption cycle etc. and are used for space heating applications in local and industrial buildings.
- d) Reversed Carnot cycle is the ideal cycle for heat pumps similar to the refrigerators.

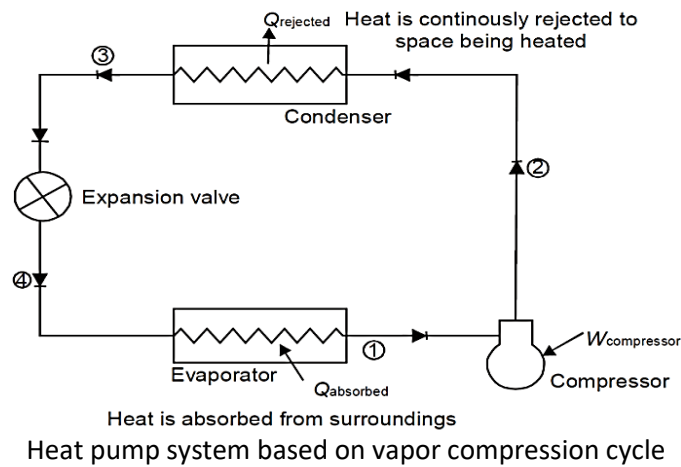

e) **Working**

(Process 1-2): Isentropic compression of refrigerant causing rise in its pressure and temperature inside compressor

(Process 2-3): Isobaric heat rejection of high pressure and temperature of refrigerant causing converting of refrigerant into liquid form in condenser and the space being heated up.

(Process 3-4): Isentropic expansion of liquid causing drop in its pressure and temperature inside expander.

(Process 4-1): Isobaric heat absorption of liquid from surroundings causing converting of liquid into gas in evaporator.

f) **COP of heat pump:**
$$COP_{heat\ pump} = \frac{\text{Desired effect (heating of space)}}{\text{Net work}} = \frac{Q_{rejected}}{\text{Work input}}$$

$$Q_{rejected} = m(h_2 - h_3), W_{compressor} = m(h_2 - h_1)$$

- **Air conditioning systems:**

- a) Air conditioning is a device used for maintaining a space at desired temperature and humidity.
- b) Air conditioning systems require different arrangements depending upon the atmospheric air condition and comfort condition requirement.
- c) Summer air conditioning system for hot and dry outdoor condition (e.g. 44°C & 20% humidity).
- d) Winter air conditioning system for cold & humid outdoor condition (e.g. 10°C & 80% humidity).
- e) Comfort conditions desired temperature and humidity. E.g. 25°C and 60% humidity.

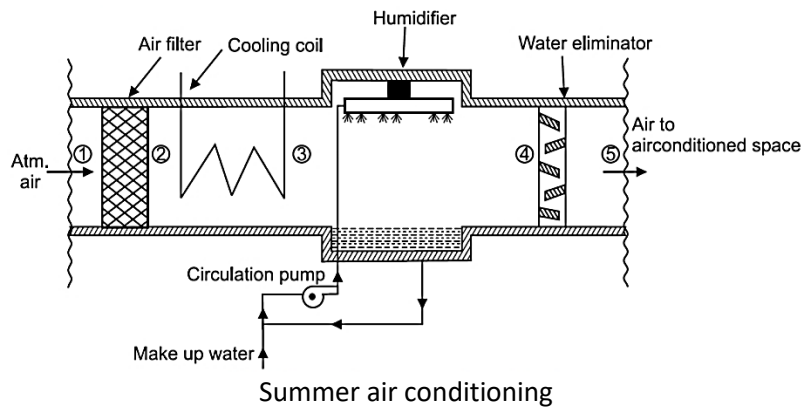

f) **Working:**

(Process 1-2 in air filter): The atmospheric air across the air filter between 1 and 2 to make the air clean.

(Process 2-3 in cooling coil): Air coming out from filter passes over cooling coil to cool the air.

(Process 3-4 in humidifier): Cold air passes through humidifier where its humidity increases.

(Process 4-5 in water eliminator): Large size water particles carried by air are retained by water eliminator.

(Process 4-5): Air finally coming out at state 5 is sent to air conditioned space.

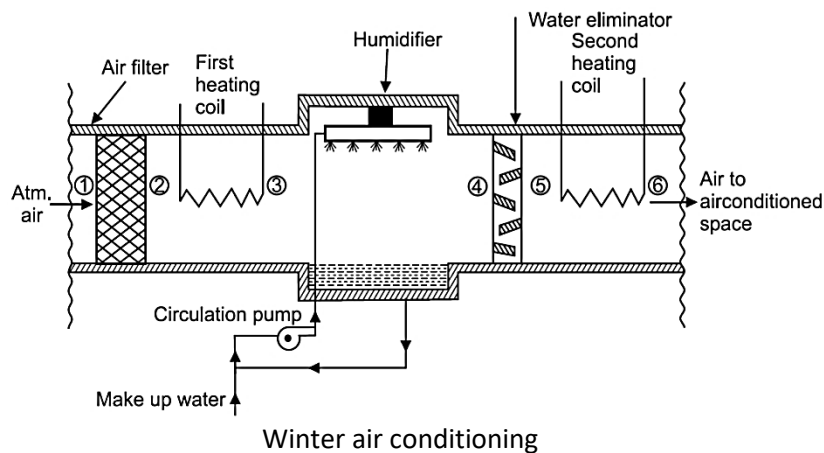

g) **Working:**

(Process 1-2 in air filter): The atmospheric air across the air filter between 1 and 2 to make the air clean.

(Process 2-3 in cooling coil): Air coming out from filter passes over first heating coil to heat the air.

(Process 3-4 in humidifier): Hot air passes through humidifier where its humidity increases.

(Process 4-5 in water eliminator): Large size water particles carried by air are retained by water eliminator.

(Process 5-6 in 2nd heating coil): Air may again be passed through 2nd heating coil to restore for temperature reduction in humidifier and achieve desired temperature.

(Process 6-7): Air finally coming out at state 5 is sent to air conditioned space.

- **Comparison of various refrigeration methods**

- Vapor compression COP is quite high while for air refrigeration COP is generally less than unity.
- Refrigerant required is smaller in vapor compression system because the heat is carried away by latent heat of vapor and so the amount of liquid refrigerant circulated per ton is less. Also size of evaporator is small.
- Operating cost of vapor compression system is very less compared to air refrigeration system.

Sl. No	Process \Rightarrow	Isobaric P=Constant	Isochoric V=Constant	Isothermal T=Constant	Isentropic S=Constant
	Detail \Downarrow				
1	Index - n	0	Infinity	1	γ
2	P-V-T relations	$\frac{v}{T} = \text{Constant}$	$\frac{p}{T} = \text{Constant}$	$PV = \text{Constant}$	$\frac{p_2}{p_1} = \left[\frac{v_1}{v_2}\right]^\gamma$ $\frac{T_2}{T_1} = \left[\frac{v_1}{v_2}\right]^{\gamma-1}$ $\frac{T_2}{T_1} = \left[\frac{p_2}{p_1}\right]^{\frac{\gamma-1}{\gamma}}$
3	Work done, W $\int_1^2 p dv$	$P(V_2 - V_1)$	0	$p_1 v_1 \ln \left[\frac{v_2}{v_1}\right]$	$\frac{p_1 v_1 - p_2 v_2}{\gamma - 1}$ $\frac{mR(T_1 - T_1)}{\gamma - 1}$
4	Heat Added dQ	$mC_p(T_2 - T_1)$	$mC_v(T_2 - T_1)$	$p_1 v_1 \ln \left[\frac{v_2}{v_1}\right]$	0
5	Change in internal Energy dU	$mC_v(T_2 - T_1)$	$mC_v(T_2 - T_1)$	0	$mC_v(T_2 - T_1)$
6	Change in Enthalpy dH	$mC_p(T_2 - T_1)$	$mC_p(T_2 - T_1)$	0	$mC_p(T_2 - T_1)$

Property Relations for closed System

CHAPTER 6

CHAPTER 6

Physics

6.1 Magnetism

- A **magnet** is an object which can attract or repel some objects such as iron pieces, bar magnet, current carrying wire or coil, moving charges, etc.
- The force exerted by a magnet is called **magnetic force (F_m)**.
- The region of space around a magnet in which an object experiences a magnetic force is called **magnetic field**.
- A **moving charge** produces magnetic field. A **current carrying conductor** produces a magnetic field.
 - a) **Work done by a magnetic force** on a moving charge is always **zero**.
 - b) Kinetic energy of the charge remains constant.
 - c) Speed of the charge remains constant (**magnetic force changes only the direction of the velocity of the charge and does not change its magnitude**).
- **Poles** of a magnet are the points where objects are most strongly attracted (or repelled).
 - a) Every magnet has two poles: a **north pole** and a **south pole**.
 - b) **Like poles repel** each other and **unlike poles attract** each other.
 - c) **Magnetic poles always exist together** and cannot be separated from each other. If a magnet is cut in half, repeatedly, each half will have a north and a south pole.
- **magnetize and demagnetize:**
 - d) There are many materials which can be magnetized either by **induction** or by prolonged **contact**.
 - e) **Soft magnetic materials** can be magnetized and demagnetized easily. E.g., iron.
 - f) **Hard magnetic materials** are difficult to magnetize and demagnetize. E.g., cobalt, nickel.
- **Magnetic Force:**

a) Lines of Magnetic Force:

- i. The lines that are drawn to show the direction of the **magnetic force** on a **north pole** are called **lines of magnetic force** or **magnetic lines**.
- ii. **Outside** the magnet, **magnetic lines** are from the **North Pole** to the **South Pole**.
- iii. **Inside** the magnet, **magnetic lines** are from the **South Pole** to the **North Pole**.

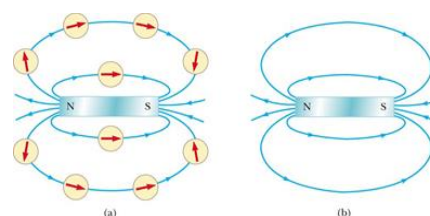

b) Magnetic Force on a Moving Charge:

- i. The magnetic force acting on a charged particle moving in a magnetic field is given as: $F_m = qvB\sin\theta$, q =electric charge, v =velocity of the charge, B =Magnetic Field, θ =angle between v and B .
- ii. Magnetic force F is always perpendicular to both v and B .
- iii. F is maximum when $\theta = 90^\circ$ (i.e. v and B are perpendicular)
- iv. F is zero when $\theta = 0^\circ$ (i.e. v and B are parallel).
- v. The direction F is given by **Right Hand Rule**.
- vi. **Magnetic Field** is given as: $B = \frac{F}{qvsin\theta}$
- vii. **SI unit** of magnetic field is the **tesla (T)** and **cgs unit** is a **gauss (G)**. [$1\text{ T} = 10^4\text{ G}$].

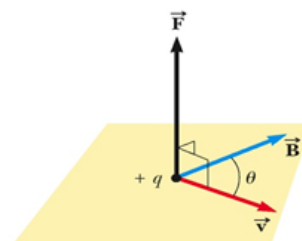

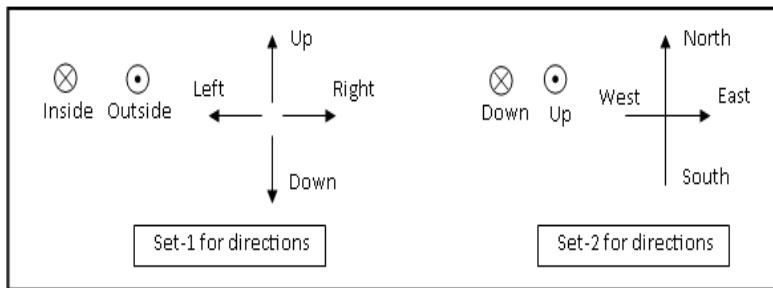

Right Hand Rule: Place fingers of your **right hand** in the direction of **B**, **thumb** in the direction of **v**, then direction of **palm** gives the direction of **F**.

- iv. **Example:** The magnetic field of the Earth at a certain location is directed vertically downward and has a magnitude of $50 \mu\text{T}$. A proton is moving horizontally toward the west in this field with a speed of $6.20 \times 10^6 \text{ m/s}$. Find the direction and magnitude of the magnetic force acting on the proton.

Sol: Here $\mathbf{B} = 50 \mu\text{T} = 50 \times 10^{-6} \text{ T}$, $q = 1.6 \times 10^{-19} \text{ C}$, $\mathbf{v} = 6.20 \times 10^6 \text{ m/s}$, $\theta = 90^\circ$.

$$F_m = qvB\sin\theta = (1.6 \times 10^{-19})(6.2 \times 10^6)(50 \times 10^{-6})(\sin 90) = 496 \times 10^{-19} \text{ N}$$

Using the **set-2 for directions** and **right hand rule**, the magnetic force is towards **south**.

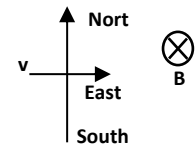

c) **Magnetic Force on a Current Carrying Conductor:**

- i. The magnetic force acting on a current carrying wire (conductor) kept in a magnetic field is given as: $F_m = ILB\sin\theta$, I = electric current in the wire, l = length of the wire, B = Magnetic Field, θ = angle between IL and B .
- ii. Magnetic force F is always perpendicular to both IL and B .
- iii. F is maximum when $\theta = 90^\circ$ (i.e. IL and B are perpendicular).
- iv. F is zero when $\theta = 0^\circ$ (i.e. IL and B are parallel).
- v. The direction F is given by **Right Hand Rule**.

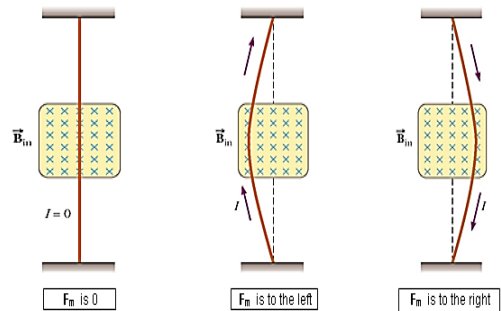

- vi. **Example:** A conductor suspended by two flexible wires as shown in the figure has a mass per unit length of 0.04 kg/m . Find the magnitude and direction of the current that must exist in the conductor for the tension in the supporting wires to be zero when the magnetic field is 3.6 T into the page.

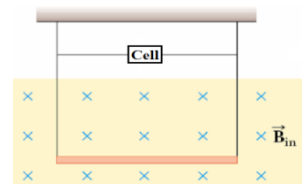

Sol: Here, mass per unit length = $\frac{m}{l} = 0.04 \text{ kg/m}$, $B = 3.6 \text{ T}$, $\theta = 90^\circ$.

For the tension in the supporting wires to be zero, $F_m = F_g$ or $ILB\sin\theta = mg$

$$I = \frac{mg}{lB\sin\theta} = \frac{0.04 \times 9.8}{3.6 \times 1} = 0.11 \text{ A.}$$

Using the **set-1 for directions** and **right hand rule**, the current is from **left to right**.

6.2 Waves

❖ Wave:

- The motion of a disturbance is called **wave**.
- All waves carry energy and momentum.
- **Example of waves:** Sound waves, waves on a string, Seismic waves (waves caused by Earthquake), Electromagnetic waves such as radio waves, micro-waves, light waves, X-rays.

❖ Types of Waves:

- **Transverse wave:** The vibrations are perpendicular to the direction of the wave velocity.
Example: wave on a stretched string, light waves.
- **Longitudinal wave:** The vibrations are parallel to the direction of the wave velocity.
Example: **sound waves, Seismic waves**, etc.
- **Mechanical Wave:** A wave that can move only in medium and not in vacuum.
Example: **sound waves, ultrasonic waves, infrasonic waves, Seismic waves**, etc.
- **Non-mechanical Wave:** A wave that can move in medium and vacuum both.
Example: **em- waves, gravitational waves, matter waves**, etc.

❖ Frequency, Amplitude and Wavelength:

- The time taken for one complete vibration is called **Period (T)**.
[SI unit: second (s)]
- Number of oscillations per second is called **frequency (f)**.
[SI unit: hertz (Hz)] $f = 1/T$
- The maximum distance a particle moves on one side of equilibrium position is called **amplitude (A)** of the wave.
[SI unit: metre (m)]
- The distance moved by the wave in one complete vibration is called **wavelength (λ)**.
[SI unit: metre (m)]
- The distance moved by the wave per second is called **wave speed (v)**.
[SI unit: metre per second (m/s)] $v = f\lambda$

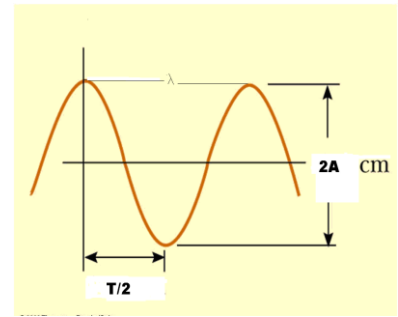

❖ Superposition of Waves:

- When two or more waves move through a medium at the same time, a new wave-form is created due to the combined effect of all the waves. This is called **superposition of waves**.

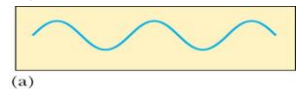

- The displacement due to resultant wave is sum of the displacements due to the individual waves. $y = y_1 + y_2 + y_3 + y_4 + \dots$

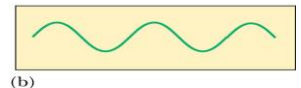

- **Interference of Waves** is the superposition of two or more waves of constant phase difference.



- **Constructive Interference occurs if the phase difference is 0 or 2π rad.**

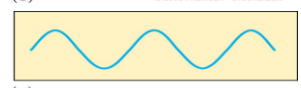

- **Maxima** are the points where amplitude is maximum due to constructive interference. Amplitude of a maximum is $A_{\max} = A_1 + A_2$

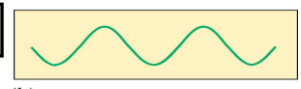

- **Destructive Interference occurs if the phase difference is π rad.**

- **Minima** are the points where amplitude is minimum due to destructive interference. Amplitude of a minimum is $A_{\min} = A_1 - A_2$



❖ **Sound waves:**

- **Sound waves** (or **audible waves**) are mechanical waves which **produce sense of hearing** in the human ear.
- Sound waves **need medium** to move (they cannot move in vacuum).
- **Range of frequency** of sound waves, for a normal person, is from **20 Hz to 20 kHz**.
- A mechanical wave having frequency below the audible range (below 20 Hz) is called **infrasound** or **infrasonic wave**. Example: Seismic waves.
- A mechanical wave having frequency above the audible range (above 20 kHz) is called **ultrasound** or **ultrasonic wave**. Example: Waves produced by bats to catch insects, waves produced by a dog-whistle.

❖ **Applications of Ultrasound (Ultrasonic Waves):**

1. They are used for detecting defects in the IC engine blocks, girders, columns, and beams of bridges and buildings, etc.
2. Widely used as a diagnostic and treatment tool in medicine.
3. Ultrasonic flow meter is used to measure blood flow.
4. Ultrasound can be used to produce images of small objects like babies in the womb.

❖ **Speed of Sound:**

- Speed of sound in a medium is given as $v = \sqrt{\frac{E}{d}}$
Here, **E**=modulus of elasticity of medium, **d**=density of medium
- For speed of sound, $v_{\text{solid}} > v_{\text{liquid}} > v_{\text{gas}}$
- Speed of sound (**v**) in air at absolute temperature **T** is given as
$$v = (331) \sqrt{\frac{T}{273K}} \text{ m/s}$$
 (331 m/s is speed of sound in air at 0°C)

Speeds of Sound in Various Media	
Medium	v (m/s)
Gases	
Air (0°C)	331
Air (100°C)	386
Hydrogen (0°C)	1 290
Oxygen (0°C)	317
Helium (0°C)	972
Liquids at 25°C	
Water	1 490
Methyl alcohol	1 140
Sea water	1 530
Solids	
Aluminum	5 100
Copper	3 560

❖ **Electromagnetic Waves and Light:**

- Waves consisting of perpendicular electric and magnetic fields varying periodically with time and space are called **electromagnetic waves** (in short **em waves**).
- **Example:** X-rays, ultra-violet rays, light, infra-red rays, micro waves, radio waves, etc.
- An electromagnetic wave which causes the sense of vision for human beings is called **light**.
- All em waves having **wavelength from 4000 Å to 7800 Å** constitute **light**.
- em waves having **wavelength less than 4000 Å** are called **ultra-violet rays**.
- em waves having **wavelength more than 7800 Å** are called **infra-red rays**.

❖ **Properties of EM Waves:**

1. The em waves are transverse waves.
2. em waves do not need medium to travel.
3. em waves travel with the speed of light **c** in vacuum.
4. The ratio of the electric field to the magnetic field is equal to the speed of light in vacuum. $c = \frac{E}{B}$
5. em waves show reflection, refraction, diffraction, interference, polarization, scattering, etc.
6. em waves carry linear momentum and energy.
7. Energy carried by em waves is shared equally by the electric and magnetic fields.

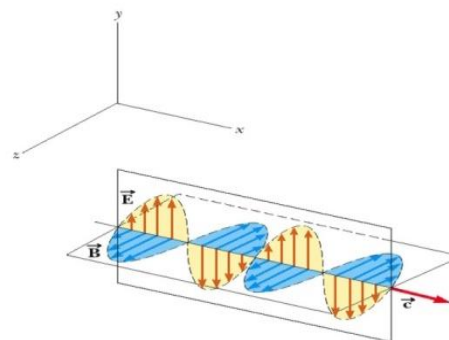

6.3 Reflection and Refraction of light

❖ Reflection of Light:

- If light is incident on a boundary separating two media, a part of the **incident light goes back into the first medium**. This is called **reflection of light**.
- The angle (θ_1) made by the **incident ray** with the normal is called **angle of incidence**.
- The angle (θ_1') made by the **reflected ray** with the normal is called **angle of reflection**.
- The angle of reflection is equal to the angle of incidence $\theta_1 = \theta_1'$
- **Note:** The normal is a line drawn perpendicular to the surface at the point where the incident ray strikes the surface.

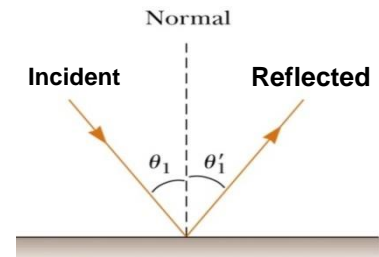

❖ Refraction of Light:

- When light travels from one transparent medium to another transparent medium, the **speed of light changes causing bending in the path of light at the boundary**. This is called **refraction of light**.
- The angle (θ_1) made by the **incident ray** with the normal is called **angle of incidence**.
- The angle (θ_2) made by the refracted ray with the normal is called **angle of refraction**.
- The incident ray, the reflected ray, the refracted ray, and the normal lie in the same plane.
- As light travels from one medium to another, its **speed and wavelength change** but **frequency does not change**.
- The **speed of light and the angle of refraction θ_2** depends on the **properties of the medium**.

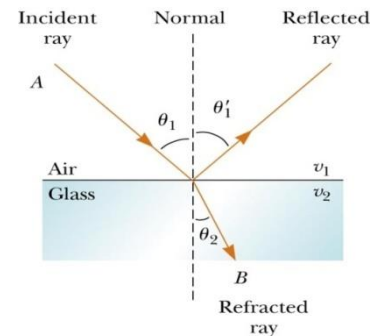

❖ Refractive Index (or Index of Refraction)

- The **ratio** of the speed of light in vacuum to the speed of light in the given medium is called **refractive index** of the medium.

- **Refractive Index,**

$$n = \frac{\text{speed of light in vacuum}}{\text{speed of light in the medium}} = \frac{c}{v}$$

- **no unit** of refractive index (n)
- For a vacuum, $n = 1$. For other media, $n > 1$

$$n_1 v_1 = n_2 v_2$$

also

$$n_1 \lambda_1 = n_2 \lambda_2$$

Here, v_1 = speed of light in medium 1, v_2 = speed of light in medium 2

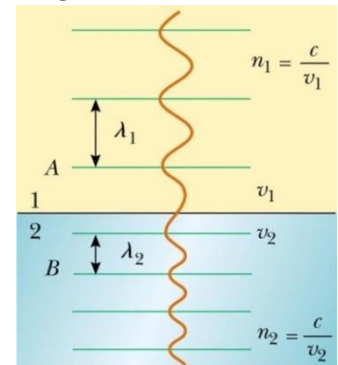

❖ Snell's Law of Refraction:

$$n_1 \sin \theta_1 = n_2 \sin \theta_2 \quad \text{or} \quad \frac{\sin \theta_1}{\sin \theta_2} = \frac{n_2}{n_1} = \text{constant}$$

Here, θ_1 = angle made by the **light ray** with the normal in medium **1**,

θ_2 = angle made by the **light ray** with the normal in medium **2**,

n_1 = refractive index of medium **1**,

n_2 = refractive index of medium **2**.

Indices of Refraction for Various Substances, Measured with Light of Vacuum Wavelength $\lambda_0 = 589 \text{ nm}$

Substance	Index of Refraction	Substance	Index of Refraction
Solids at 20°C		Liquids at 20°C	
Diamond (C)	2.419	Benzene	1.501
Fluorite (CaF ₂)	1.434	Carbon disulfide	1.628
Fused quartz (SiO ₂)	1.458	Carbon tetrachloride	1.461
Glass, crown	1.52	Ethyl alcohol	1.361
Glass, flint	1.66	Glycerine	1.473
Ice (H ₂ O) (at 0°C)	1.309	Water	1.333
Polystyrene	1.49		
Sodium chloride (NaCl)	1.544	Gases at 0°C, 1 atm	
Zircon	1.923	Air	1.000 293
		Carbon dioxide	1.000 45

- **Example 1:** A laser beam is incident at an angle of 30° to the vertical onto a solution of corn syrup in water. If the beam is refracted to 19.24° to the vertical, **(a)** what is the refractive index of the syrup solution? Suppose the light is red, with wavelength 632.8 nm in a vacuum. Find its **(b)** wavelength, **(c)** frequency, and **(d)** speed in the solution.

Sol:

(a) Here, angle of incidence, $\theta_1=30^\circ$, angle of refraction, $\theta_2=19.24^\circ$, & refractive index of air, $n_1=1$

\therefore Using Snell's Law, $n_1 \sin \theta_1 = n_2 \sin \theta_2$, we get refractive index of the syrup solution as

$$n_2 = n_1 \frac{\sin \theta_1}{\sin \theta_2} = 1 \times \frac{\sin 30}{\sin 19.24} = 1.517.$$

(b) Here, $\lambda_1=632.8 \text{ nm}$, $n_1 = 1$, $n_2 = 1.517$ $\therefore n_1 \lambda_1 = n_2 \lambda_2 \Rightarrow \lambda_2 = \lambda_1 \frac{n_1}{n_2} = 632.8 \times \frac{1}{1.517} = 417.14 \text{ nm}$

(c) For air, $v = c = 3 \times 10^8 \text{ m/s}$. $\therefore v = f \lambda$ gives $f = \frac{v}{\lambda} = \frac{3 \times 10^8}{632.8 \times 10^{-9}} = 4.741 \times 10^{14} \text{ Hz}$.

(d) Frequency of light does not change with medium. \therefore Speed of light in the solution is

$$v = f \lambda = 4.741 \times 10^{14} \times 417.14 \times 10^{-9} = 1.978 \times 10^8 \text{ m/s}.$$

- ❖ When the light goes **from rarer medium to denser medium**, the ray **bends toward the normal**.

\Rightarrow Angle of Refraction is less than Angle of Incidence, i.e. $\theta_2 < \theta_1$

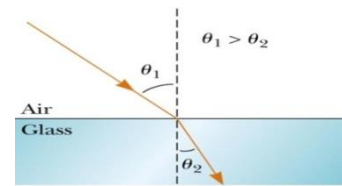

- ❖ When the light goes **from denser medium to rarer medium**, the ray **bends away from the normal**.

\Rightarrow Angle of Refraction is greater than Angle of Incidence, i.e. $\theta_2 > \theta_1$

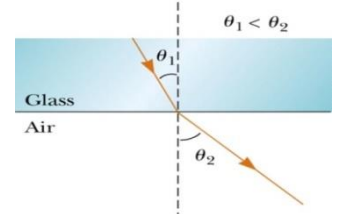

- ❖ **Critical angle:** It is the angle of incidence in denser medium for which the **angle of refraction is 90°** .

So, $n_1 \sin \theta_c = n_2 \sin 90 \Rightarrow$

$$\sin \theta_c = \frac{n_2}{n_1} \quad \text{for } n_1 > n_2$$

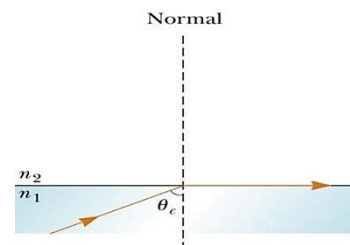

- ❖ **Total Internal Reflection:**

- If the **angle of incidence in denser medium is greater than the critical angle**, then light is **completely reflected** into the denser medium. This is called **Total Internal Reflection**.
- Total internal reflection can occur if light attempts to move from a denser medium to a rarer medium.
- Ray 5 shows Total Internal Reflection

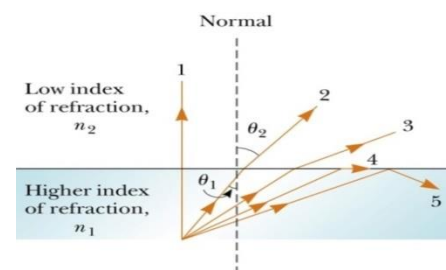

- ❖ **Applications of Total Internal Reflection:**

- **Optical Fibre** is a very thin plastic or glass rod which can carry light from one place to another using the principle of **total internal reflection**.

- **Uses of Optical Fiber:**

- 1) Telecommunications
- 2) For the diagnosis and correction of medical problems.

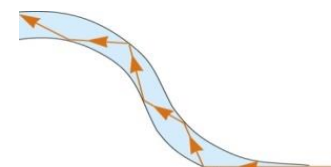

6.4 Ac Circuits

- A current whose **magnitude** and **direction changes periodically with time** is called **alternating current** or **AC**.
- An **AC circuit** consists of AC generator (source) connected across a combination of circuit elements (resistors, capacitors, inductors, etc.).
- The output of **AC generator** is given as: $V = V_o \sin \omega t$

Here, $\omega = 2\pi f$ = angular frequency of AC, V = instantaneous voltage or voltage at time t , V_o = maximum voltage or peak voltage or amplitude of voltage.

- **Current** is the **simplest** possible **alternating current**. It is given as: $I = I_o \sin \omega t$
- Here, I = instantaneous current or current at time t ,
 I_o = maximum current or peak current or amplitude of current.

- The **average value of current** and **voltage** over a **complete cycle** in an **AC circuit** is **zero**.

- Instead of average value we find **root mean square (rms) value** of **AC current** and **voltage**.

- **rms Voltage:** $V_{rms} = \frac{V_o}{\sqrt{2}} = 0.707 V_o$ and **rms Current:** $V_{rms} = \frac{V_o}{\sqrt{2}} = 0.707 V_o$

- Usually, **rms** values are used when discussing AC currents and voltages.
- **AC ammeters** and **voltmeters** are designed to read **rms values**.
- **AC voltages and currents can be combined using arrows** similar to the method for vectors and such a diagram is called **phasor diagram**.

S. No.	Quantity	SI Unit	S. No.	Quantity	SI Unit
1	Current (I)	ampere (A)	6	Frequency (f)	hertz (Hz)
2	Voltage (V)	volt (V)	7	Angular Frequency (ω)	radian/second (rad/s)
3	Resistance (R)	ohm (Ω)	8	Reactance (X)	ohm (Ω)
4	Inductance (L)	henry (H)	9	Impedance (Z)	ohm (Ω)
5	Capacitance (C)	farad (F)	10	Power (P)	watt (W)

❖ Resistor in an AC Circuit:

Consider a circuit consisting of an AC source and a resistor.

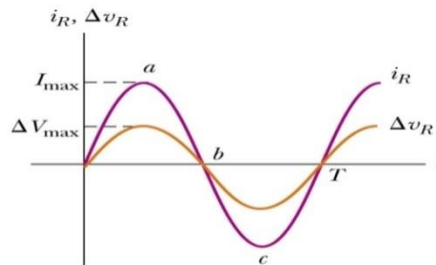
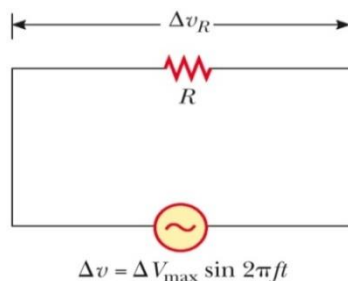

- Voltage across the **resistor is in phase** with the current ($\phi = 0$).
- **Ohm's Law** in an AC circuit with a resistor (R) is given as

$$V_{rms} = I_{rms} R \text{ also } V_o = I_o R$$

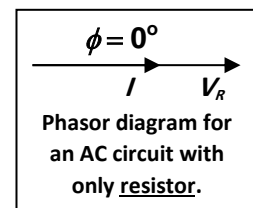

❖ **Capacitor in an AC Circuit:**

Consider a circuit containing a capacitor and an AC source.

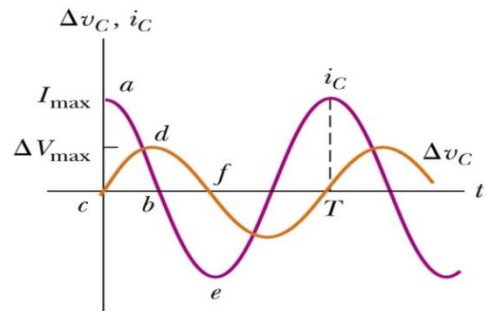
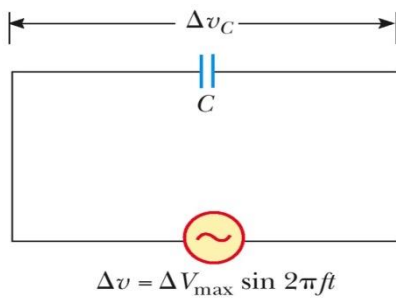

- **Voltage** across the capacitor **lags behind the current by 90° ($\phi = -90^\circ$)**.
- **Capacitive Reactance** is the opposition to AC by **capacitor**.

It is given as
$$X_C = \frac{1}{\omega C}$$
 (SI unit of $X_C = \text{ohms}$).

Here, ω = angular frequency of AC and C = capacitance of the capacitor.

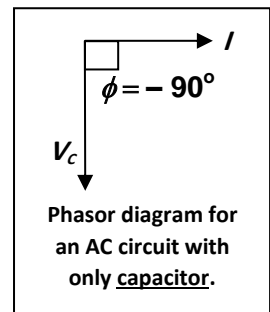

- For a capacitor in an AC circuit, the rms voltage is given by $V_{rms} = I_{rms} X_C$

❖ **Inductors in an AC Circuit**

Consider an AC circuit with a source and an inductor.

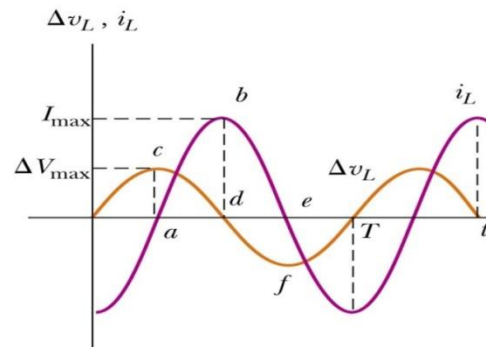
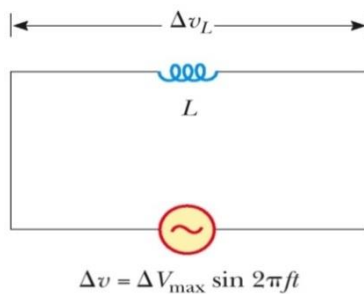

- **Voltage** across the inductor always **leads the current by 90° ($\phi = 90^\circ$)**.
- The current in the circuit is impeded by the back emf of the inductor.
- **Inductive Reactance** is the opposition to ac by an **inductor**.

It is given as
$$X_L = \omega L$$
 (SI unit of $X_L = \text{ohms}$).

Here ω = angular frequency of AC and L = inductance of the inductor.

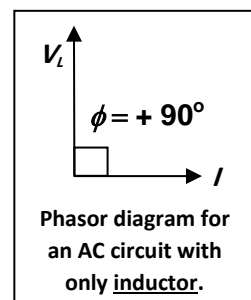

- For an inductor in an AC circuit, the rms voltage is given by $V_{rms} = I_{rms} X_L$

❖ **RLC Series Circuit:**

In a series RLC circuit a resistor, an inductor, and a capacitor are connected in series across an AC source. The current in each circuit element is the same at any time and varies sinusoidally with time.

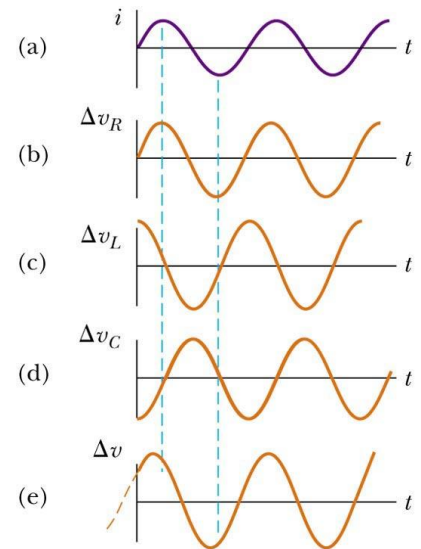
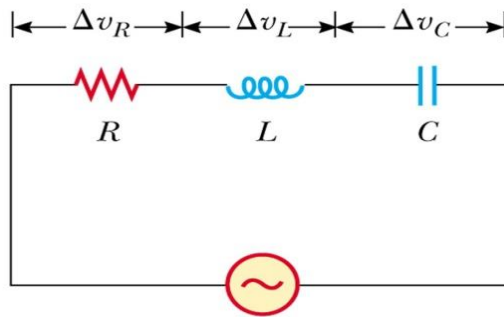

❖ **Current and Voltage Relationship in an RLC Circuit:**

- Instantaneous voltage across the **resistor** is **in phase** with the current.
- Instantaneous voltage across the **inductor** **leads the current by 90°**.
- Instantaneous voltage across the **capacitor** **lags the current by 90°**.

❖ **Impedance of an AC Circuit:**

- Impedance is the **net opposition** to ac by a combination of **resistors, inductors, and capacitors**.

It is given as $Z = \sqrt{R^2 + X^2}$ where $X = X_L - X_C = \text{Reactance of the ac circuit.}$

- The phase difference ϕ between voltage and current is given as

$$\tan \phi = \frac{X}{R}$$

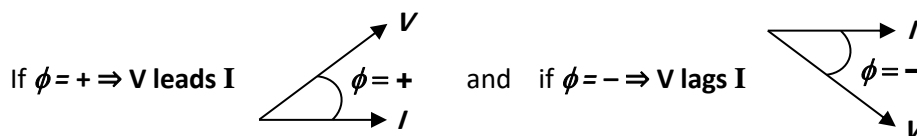

- For a combination of **resistors, inductors** and **capacitors** in an AC circuit, the rms voltage is given by $V_{rms} = I_{rms} Z$

This can be regarded as a generalized form of Ohm's Law for a series AC circuit.

❖ **Average Power Dissipated in an AC Circuit:**

$$P = V_{rms} I_{rms} \cos \phi \quad \text{Here,} \quad \cos \phi = \frac{R}{Z}$$

- For a **purely resistive AC circuit**, $\phi = 0 \Rightarrow \cos \phi = 1 \Rightarrow P = V_{rms} I_{rms}$.
- For a **purely reactive AC circuit** ($R = 0 \Rightarrow Z = X$), $\phi = 90^\circ \Rightarrow \cos \phi = 0 \Rightarrow P = 0$.

Such a circuit is called **watt-less circuit** because **no loss of power** in the circuit.

6.5 Kinetic Theory of Gases

❖ Properties of Ideal Gas:

1. The **volume of a molecule** of an ideal gas is **zero**.
2. **Molecules move randomly** in all possible directions inside the container.
3. There is **no force between the molecules** except during their collisions.
4. Molecules have only kinetic energy and do **not** have **potential energy**.
5. Ideal Gas **cannot be liquefied**.

❖ Avogadro's Hypothesis:

- Equal volumes of gas at the same temperature and pressure contain same number of molecules.
- **Example:** If **gas 1** and **gas 2** are at same temperature T and same pressure P and if their **volumes** are also **equal** then $N_1 = N_2$. Here N_1 = number of molecules of **gas 1** and N_2 = number of molecules of **gas 2**.
- The number of particles in a mole of a substance is called **Avogadro's Number (N_A)**.

$$N_A = 6.02 \times 10^{23} \text{ particles/mol}$$
- **Example:** 12 g of **carbon** contains N_A atoms.

$$\text{Mass of an atom: } m_{atom} = \frac{\text{molar mass}}{N_A}$$

Number of Moles of a Substance in a sample:

$$n = \frac{\text{mass of the sample}}{\text{molar mass of the substance}} = \frac{m}{M} \quad \text{Also } n = \frac{\text{number of molecules in the sample}}{\text{Avogadro's number}} = \frac{N}{N_A}$$

❖ Ideal Gas Equation of State:

$$PV = nRT$$

Here, **P** = pressure of the gas, **V** = volume of the gas,

R = the Universal Gas Constant (**R = 8.31 J / mole.K**),

T = **absolute temperature** of the gas,

n = number of moles of the gas.

From ideal gas equation of state, we get
$$\boxed{\frac{P_f V_f}{T_f} = \frac{P_i V_i}{T_i}}$$

Here, P_i = initial pressure of the gas, P_f = final pressure, V_i = initial volume of the gas, V_f = final volume, T_i = initial **absolute temperature** of the gas, and T_f = final **absolute temperature**.

- **Example 3:** A cylinder with a movable piston contains gas at a temperature of 27.0 °C, a volume of 1.50 m³, and an absolute pressure of 0.200 × 10⁵ Pa. What will be its final temperature if the gas is compressed to 0.700 m³ and the absolute pressure increases to 0.800 × 10⁵ Pa?

Sol: Here $T_i = 27.0 \text{ }^\circ\text{C} = 27 + 273.15 = 300.15 \text{ K}$, $V_i = 1.50 \text{ m}^3$, $P_i = 0.200 \times 10^5 \text{ Pa}$, $V_f = 0.700 \text{ m}^3$, and $P_f = 0.800 \times 10^5 \text{ Pa}$.

$$\therefore \frac{P_f V_f}{T_f} = \frac{P_i V_i}{T_i} \Rightarrow T_f \frac{P_f V_f}{P_i V_i} T_i = \frac{0.800 \times 10^5 \times 0.700}{0.200 \times 10^5 \times 1.50} \times 300.15 = 560.28 \text{ K}$$

❖ **Main Assumptions of Kinetic Theory of Gases:**

1. The number of molecules in a gas is very large.
2. All the molecules of a gas are identical.
3. Gas molecules have only KE and do not have any PE.
4. Gas **molecules move randomly** in all possible directions.
5. Gas molecules obey **Newton's laws of motion**.
6. Gas molecules interact only by short-range forces during elastic collisions.
7. Gas molecules make **elastic collisions** among themselves and with the walls of the container.
8. The average separation between the molecules is large compared to their size.

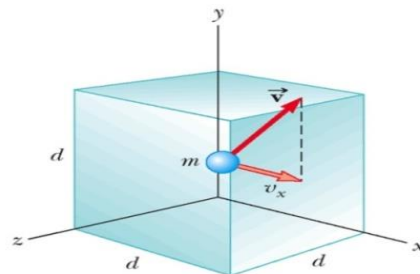

❖ **Using Kinetic Theory of Gases we get:**

• **Average kinetic energy of a gas molecule:** $\overline{KE}_{molecule} = \frac{1}{2} m \overline{v^2} = \frac{3}{2} K_B T$

m = mass of the gas molecule, $\overline{v^2}$ = Average of the square of speed of all the molecules of the gas, $k_B = \frac{R}{N_A} = 1.38 \times 10^{-23} \text{ J / K}$ = Boltzmann's constant, T = absolute temperature of the gas.

Temperature of the gas is proportional to the average kinetic energy of its molecules.

Total kinetic energy of all the molecules in the gas: $KE_{total} = \frac{3}{2} nRT$

• **Pressure of an ideal gas:** $P = \frac{3}{2} \left(\frac{N}{V}\right) \left(\frac{1}{2} m \overline{v^2}\right)$ or $PV = 1.5 N \overline{KE}_{molecule}$

Pressure of an ideal gas can be increased by:

1. Increasing the number of molecules per unit volume in the container.
2. Increasing the average KE of the molecules (by increasing the temperature of the gas).

• **Root-Mean-Square (rms) speed of the gas molecules:** $v_{rms} = \sqrt{\frac{3 k_B T}{m}} = \sqrt{\frac{3 R T}{M}}$

⇒ **At a given temperature, on an average, lighter molecules move faster, than heavier ones.**

- **Example:** A sealed cubical container 20.0 cm on a side contains three times Avogadro's number of molecules at a temperature of 20.0°C. Find force exerted by gas on one of the walls of container.

Sol: Here, number of molecules in the gas, $N = 3N_A \Rightarrow n = \frac{N}{N_A} = 3$.

Volume of gas, V = volume of cubical container = $l^3 = (0.2)^3 \text{ m}^3$.

From ideal gas law, $PV = nRT \Rightarrow P = \frac{nRT}{V} = \frac{3 \times 8.31 \times 293}{0.008} = 9.13 \times 10^5 \text{ Pa}$

But, pressure, P = force/area. Here, area of a wall $A = l^2 = (0.2)^2 \text{ m}^2$.

∴ $P = F/A \Rightarrow F = PA = 9.13 \times 10^5 \times (0.2)^2 = 3.65 \times 10^4 \text{ N}$.

❖ **Internal Energy (U):**

- **Internal energy** of a gas is the **sum of KE and PE of all the molecules (or atoms)** of the gas.
- Internal energy of a **monatomic** gas is only due to **translational KE** of its molecules,
- **U** of a **polyatomic** gas is due to **translational KE, rotational KE, & vibrational KE** of its molecules.

Some rms Speeds		
Gas	Molar Mass (kg/mol)	v_{rms} at 20°C (m/s)
H ₂	2.02×10^{-3}	1 902
He	4.0×10^{-3}	1 352
H ₂ O	18×10^{-3}	637
Ne	20.2×10^{-3}	602
N ₂ and CO	28.0×10^{-3}	511
NO	30.0×10^{-3}	494
O ₂	32.0×10^{-3}	478
CO ₂	44.0×10^{-3}	408
SO ₂	64.1×10^{-3}	338

6.6 Modern physics

❖ Main Features of Modern Physics:

- Matter and energy are **inter-convertible** which is described by **Einstein's mass-energy relation** $E = mc^2$.
- Matter and energy have **dual nature**:
 1. **wave nature**
 2. **particle nature.**
- **Particle nature** is described by quantities like **mass (m)** and **momentum (p)**.
- **Wave nature** is described by quantities like **frequency (f)** and **wavelength (λ)**.
- Usually we observe the particle nature of matter (e.g.: ball, atom, electron, etc.) and wave nature of energy (e.g.: X-rays, light, radio-waves, etc.).
- Waves related to matter are called **Matter waves**.
- Particles related to energy are called **Photons**.
- The **energy, linear momentum, angular momentum, charge**, etc. of molecules, atoms, protons, neutrons, and electrons are **quantized**.
- Values of **velocity, distance, time**, etc. depend on the **relative motion** of the object and observer.

❖ Planck's Hypothesis:

- Atoms emit and absorb energy in the form of particles, called photons.
- An atom can emit or absorb only one photon at a time.
- **Energy of a photon** is $E = hf$.

Here **h** is **Planck's constant** ($h = 6.62 \times 10^{-34}$ J.s) & **f** is **frequency** of the wave that carries this energy.

❖ de-Broglie Hypothesis:

- Matter has dual nature; sometimes it behaves like particle and sometimes like waves.
- **De-Broglie wavelength** is given as: $\lambda = h/p$.
- It is the **wavelength of the matter waves** for a particle having **linear momentum p**.

❖ Lasers: It is an acronym of **Light Amplification by Stimulated Emission of Radiation**.

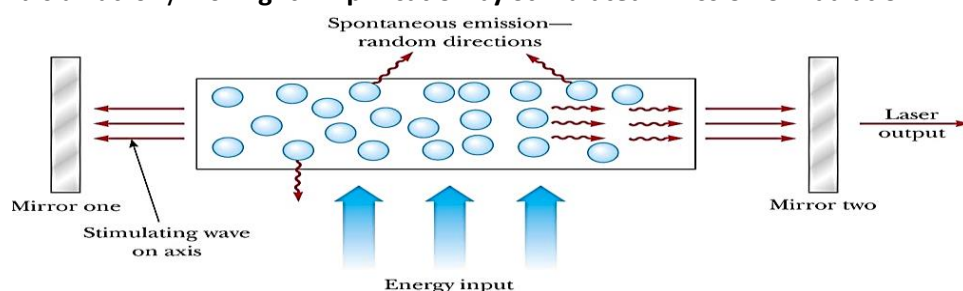

• Main conditions for laser action:

1. The excited state of the system must be a **metastable state (its lifetime must be longer than the lifetime of a normal excited state)**.
2. System must be in a state of **population inversion (more atoms in an excited state than in the ground state)**.
3. The emitted photons must be confined in the system long enough to allow them to stimulate further emission from other excited atoms. This is achieved by using reflecting mirrors as shown in the figure.

- **Properties of Laser Light:**
 1. It is highly monochromatic.
 2. It is highly intense.
 3. It is highly directional.
 4. It is highly coherent.

❖ **Photoelectric Effect:**

1. When light of suitable frequency falls on a metallic surface, electrons are emitted from the surface. This is called the **photoelectric effect**.
2. The emitted electrons are called **photoelectrons**.
3. The **kinetic energy** of photoelectrons increases with the **frequency** of the light.
4. The **number** of photoelectrons increases with the **intensity** of the light.
5. Photoelectric effect shows **particle nature** of light.

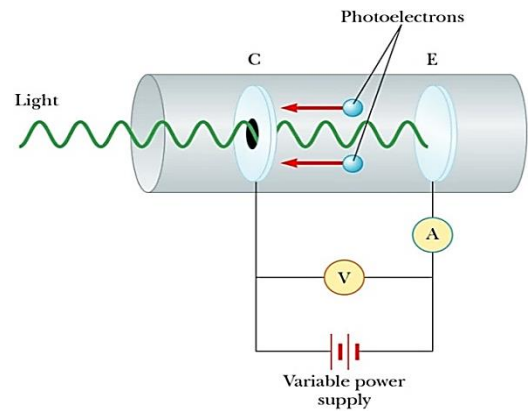

❖ **X-Rays:**

1. X-rays are electromagnetic radiations with **very short wavelengths** (about 0.1 nm).
2. In an X-ray tube, electrons are emitted by heating a filament.
3. These electrons are accelerated toward a dense metal target that is held at a very high potential than the filament.
4. X-rays are produced when **very high-speed electrons** are retarded or stopped suddenly by a suitable target.
5. The high-speed electrons **go deep into the atoms** of the target and interact with their inner electrons and nucleus.
6. X-rays can **pass through dense objects** like animal tissues, wood, plastics, thin metal sheets, etc.
7. X-rays show that the **energy of electrons is quantized** in an atom.

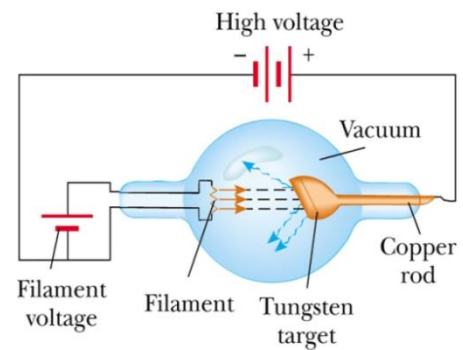

CHAPTER 7

Chemistry

7.1 Chemical Formulae and Equations

- **Chemistry** is the science that studies the matter and its properties and changes.
- **Matter** is anything that has a mass and occupies a space.

❖ Isotope notation:

- Every element in the periodic table is shortly represented called as chemical symbol.
- Mass number = A; Atomic number = Z; Element symbol = X
- The isotopes of an element include all of those with the same number of protons or atomic number but with different mass numbers which is a change in the number of neutrons.
- E.g. $^{12}_6\text{C}$ $^{13}_6\text{C}$ $^{14}_6\text{C}$ (Isotopes of the chemical element carbon)
- E.g. $^{12}_6\text{C}$: **Atomic number Z** = 6 = number of electrons = number of protons
No of electrons e^- = 6 , No of protons p = 6

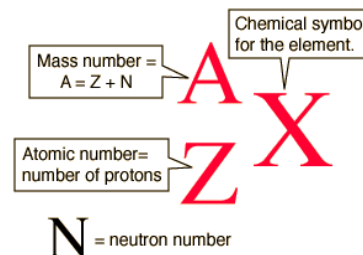

❖ The Periodic Table:

Periodic Table of the Elements
Colored by Type

1A	2A											3A	4A	5A	6A	7A	0	
1 H 1.00797																		2 He 4.0026
3 Li 6.941	4 Be 9.0122											5 B 10.811	6 C 12.01115	7 N 14.0067	8 O 15.9994	9 F 18.9984	10 Ne 20.179	
11 Na 22.9898	12 Mg 24.305											13 Al 26.9815	14 Si 28.086	15 P 30.9738	16 S 32.064	17 Cl 35.453	18 Ar 39.948	
		3B	4B	5B	6B	7B	8B		1B	2B								
19 K 39.098	20 Ca 40.08	21 Sc 44.956	22 Ti 47.90	23 V 50.942	24 Cr 51.996	25 Mn 54.9380	26 Fe 55.847	27 Co 58.9332	28 Ni 58.70	29 Cu 63.54	30 Zn 65.38	31 Ga 69.72	32 Ge 72.59	33 As 74.9216	34 Se 78.96	35 Br 79.904	36 Kr 83.80	
37 Rb 85.47	38 Sr 87.62	39 Y 88.905	40 Zr 91.22	41 Nb 92.906	42 Mo 95.94	43 Tc (99)	44 Ru 101.07	45 Rh 102.905	46 Pd 106.4	47 Ag 107.868	48 Cd 112.41	49 In 114.82	50 Sn 118.69	51 Sb 121.75	52 Te 127.60	53 I 126.9045	54 Xe 131.30	
55 Cs 132.905	56 Ba 137.58	71 Lu 138.91	72 Hf 178.49	73 Ta 180.948	74 W 183.85	75 Re 186.2	76 Os 190.2	77 Ir 192.2	78 Pt 195.09	79 Au 196.967	80 Hg 200.59	81 Tl 204.37	82 Pb 207.19	83 Bi 208.980	84 Po (210)	85 At (210)	86 Rn (222)	
87 Fr (223)	88 Ra 226.0254	103 Ac (227)	104 Rf (257)	105 Db (260)	106 Sg	107 Bh	108 Hs	109 Mt	110 Ds	111 Rg	112 Cn	113 Uut	114 Fl	115 Uup	116 Lv	117 Uus	118 Uuo	

Inner transition metals													
Lanthanides							Actinides						
58 Ce 140.12	59 Pr 140.9077	60 Nd 144.24	61 Pm (147)	62 Sm 150.35	63 Eu 151.96	64 Gd 157.25	65 Tb 158.925	66 Dy 162.50	67 Ho 164.930	68 Er 167.26	69 Tm 168.934	70 Yb 173.04	71 Lu 174.967
90 Th 232.0377	91 Pa 231.036	92 U 238.0289	93 Np 237.0482	94 Pu (242)	95 Am (243)	96 Cm (247)	97 Bk (247)	98 Cf (251)	99 Es (254)	100 Fm (254)	101 Md (258)	102 No (259)	103 Lr (260)

❖ Classification of Matter:

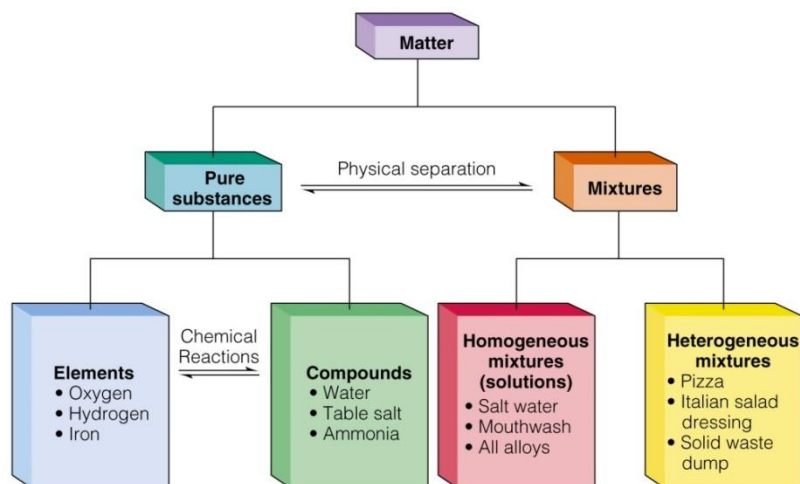

❖ Atoms and ions

- **Atoms** are electrically neutral, because the number of protons and electrons are same.

a) The atom consists of a very small central nucleus.

- 1) Electron e^- (have negative charge)
- 2) Protons p (have positive charge)
- 3) Neutrons n (no charge)

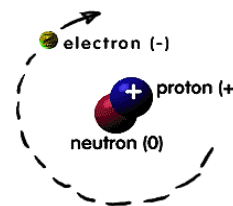

b) Arrangement or configurations of Electrons:

- 1) The electrons around an atom are defined "**shell**"
- 2) **Shell** can contain a maximum number of electrons.
- 3) Shell with the lowest energy fills first.
- 4) The maximum number of electrons in each shell can be given by the formula: $2n^2$ (n = Shell number).
- 5) **E.g.** Maximum number of electrons in shell 1 is 2 and in shell 2 is 8 etc.
- 6) E.g. the electronic configurations and the electronic structure for Sodium.

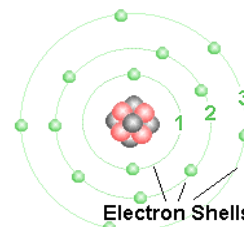

Sodium: ${}^{23}_{11}\text{Na}$, No. of $e^- = 11$

1st. Shell	2nd. Shell	3rd Shell
2	8	1

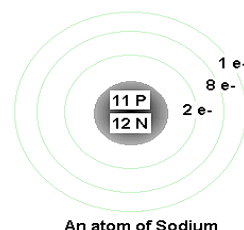

- **An ion** is an atom, or group of atoms, that has a net positive or negative charge. E.g.: Ca^+ ; 11 protons, 10 (11 - 1) electrons. Cl^- ; 17 protons, 18 (17 + 1) electrons.
- **Anion** – ion with a negative charge – if a neutral atom gains one or more electrons it becomes an anion. E.g.; **Nonmetals**.

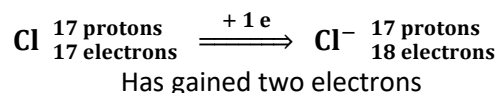
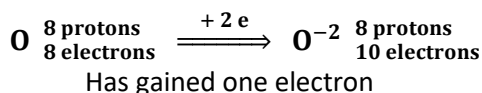

- **Cation** – ion with a positive charge – if a neutral atom loses one or more electrons it becomes a cation. E.g.; **Metals**.

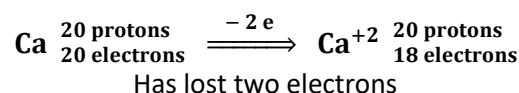
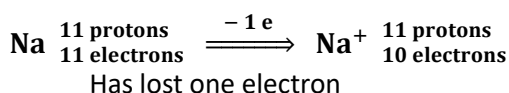

❖ Rules for writing Formula:

• Binary Ionic Compounds (type I) :

- 1) Every binary compound has 2 parts, First part is positive (Cation) and the second is negative (anion). E.g: Aluminium oxides (Al_2O_3); Aluminium (Al^{+3}) is positive & Oxygen (O^{-2}) is negative
- 2) The second part generally ends with "ide" (For single element only) or "ite and ate" (For element in combination with Oxygen). E.g.: Chloride (Cl^-), Oxide (O^{-2}), Nitride (N^{-3}), Sulphide (S^{-2}) and Sulphite (SO_3^{-2}), Nitrite (NO_2^-), Sulphate (SO_4^{-2}), Nitrate (NO_3^-), Phosphate (PO_4^{-3}).
- 3) Firstly write the chemical symbol for the first part (include charge as superscript) followed by the chemical symbol for the last part (include charge as superscript). E.g. Aluminium oxides Al^{+3} and O^{-2} .
- 4) Criss-Cross the valences (only the numbers) to obtain the subscripts. Example: $\text{Al}_2^{+3} \text{O}_3^{-2}$
Note: Only the numbers are criss-crossed, not the charges.

- 5) The total positive valence + the total negative valence must equal to zero (an overall charge of 0) Example: for water (H₂O); (2 times +1) + (1 times -2) = 0
- 6) Use the lowest possible ratio of subscripts (similar to reducing fractions). E.g. Ca₁⁺²O₁⁻² has subscripts of "1" and "1" NOT "2" and "2".
- 7) Enclose all polyatomic ions in parentheses (leave the valence outside the parentheses). (Do not use parentheses for monatomic ions). E.g. (NH₄)₂⁺¹ S₁⁻²

Cation	Name	Anion	Name
H ⁺	Hydrogen	H ⁻	Hydride
Li ⁺	Lithium	F ⁻	Fluoride
Na ⁺	Sodium	Cl ⁻	Chloride
K ⁺	Potassium	Br ⁻	Bromide
Cs ⁺	Cesium	I ⁻	Iodide
Be ⁺²	Beryllium	O ⁻²	Oxide
Mg ⁺²	Magnesium	S ⁻²	Sulfide
Ca ⁺²	Calcium	N ⁻³	Nitride
Ba ⁺²	Barium	P ⁻³	Phosphide
Al ⁺³	Aluminum		
Ag ⁺	Silver		

Common Monatomic Cations and Anions

- **Binary Ionic compounds (Type II):**

- 1) They contain a transition metal (except Zn⁺², Ag⁺ and Cd⁺²) that can form more than one type of cation charge and form more than one type of ionic compound.
- 2) The cation is mentioned first then anion as in case of binary ionic compounds type I .
- 3) The charge on cation must be determined by balancing the positive and negative charges of the compound. E.g. Co⁺² Br⁻ ; CoBr₂; (1 times +2) + (2 times -1) = 0

I	2	3	4	5	6	7	8	9	10	11	12	13	14	15	16	17	18	19	20
I	II	III	IV	V	VI	VII	VIII	IX	X	XI	XII	XIII	XIV	XV	XVI	XVII	XVIII	XIX	XX

Roman Numerals

Ion	Systematic Name	Ion	Systematic Name
Fe ⁺³	Iron(III)	Pb ⁺⁴	Lead(IV)
Fe ⁺²	Iron(II)	Pb ⁺²	Lead(II)
Cu ⁺²	Copper(II)	Hg ⁺²	Mercury(II)
Cu ⁺	Copper(I)	Hg ₂ ⁺²	Mercury(I)
Co ⁺³	Cobalt(III)	Ag ⁺	Silver
Co ⁺²	Cobalt(II)	Zn ⁺²	Zinc
Sn ⁺⁴	Tin(IV)	Cd ⁺²	Cadmium
Sn ⁺²	Tin(II)		

Common Type II Cations

- Note that mercury (I) ions always occurs bound together to form Hg₂⁺² ions. Although these are transition metals, they form only one type of ion, and a Roman numeral is not used.

- **Compounds with Polyatomic Ions:**

- 1) Polyatomic ions are groups of atoms that stay together and have a charge.
- 2) The cation is listed first and the anion second.
- 3) The polyatomic ion names must be memorized.
- 4) No extra suffixes are added.

Ion	Name	Ion	Name
OH^-	Hydroxide	CN^-	Cyanide
NO_2^-	Nitrite	PO_4^{3-}	Phosphate
NO_3^-	Nitrate	NH_4^+	Ammonium
SO_3^{2-}	Sulfite	Hg^+	Mercury(II); Mercurous
SO_4^{2-}	Sulfate	Hg_2^{+2}	Mercury(I); Mercuric
HSO_4^-	Bisulfate	CO_3^{2-}	Carbonate
MnO_4^-	Permanganate	HCO_3^-	Bicarbonate

Common Polyatomic Ions

• **Binary Covalent Compounds (Type III):**

- 1) Binary compound has 2 parts, First part is cation and the second is anion.
- 2) Covalent means Nonmetals are present.
- 3) Prefixes are used to denote the number of atoms present in cation and anion.
- 4) The prefix **mono** is never for naming the first element. E.g. CO_2
- 5) Drop the final **o** or **a** of the prefix when the element begins with a vowel. E.g. N_2O_4 dinitrogen tetroxide.

1	2	3	4	5	6	7	8	9
mono	di	tri	tetra	penta	hexa	hepta	octa	nona

Prefixes

Number of atoms	Prefix	Example
1	mono	NO : nitrogen monoxide
2	di	NO₂ : nitrogen dioxide
3	tri	N₂O₃ : dinitrogen trioxide
4	tetra	N₂O₄ : dinitrogen tetroxide
5	penta	N₂O₅ : dinitrogen pentaoxide
6	hexa	SF₆ : Sulphur hexa fluoride
7	hepta	IF₇ : iodine hepta fluoride
8	octa	P₄O₈ : tetra phosphor decoxide
9	nona	P₄S₉ : tetra phosphor nona sulphide
10	deca	AS₄O₁₀ : tetra arsenic decoxide

Common Binary Covalent Compounds (Type III)

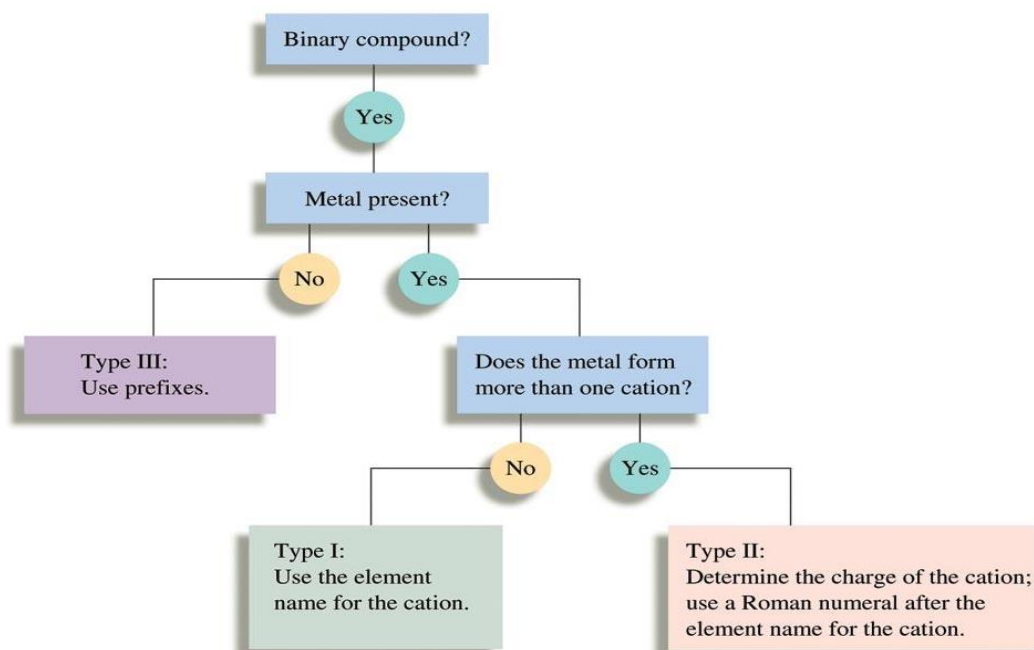

Naming of Binary Compounds

- **Acids**

- 1) Acids are substances that dissociate in water to produce hydrogen ions, H^+ (H_3O^+).
E.g. $HCl + H_2O \rightarrow H_3O^+ + Cl^-$
- 2) If the anion doesn't contain oxygen, the acid is named as **hydro + (anion root + ic) + acid**.
E.g. HCl (hydrochloric acid).
- 3) If the anion contains oxygen and the anion name ends with **-ate**, the acid is named as **(anion root + ic) + acid**. E.g. HNO_3 "Nitrate anion" (**Nitric acid**), H_2CO_3 "Carbonate anion" (**Carbonic acid**), H_2SO_4 "Sulfate anion" (**Sulfuric acid**), H_2PO_4 "Phosphate anion" (**Phosphoric acid**).
- 4) If the anion contains oxygen and the anion name ends with **-ite**, the acid is named as **(anion root + ous) + acid**. E.g. HNO_2 "Nitrite anion" (**Nitrous acid**), H_3PO_3 "Phosphite anion" (**Phosphorous acid**).

Acid	Name
HF	Hydrofluoric acid
HCl	Hydrochloric acid
HBr	Hydrobromic acid
HI	Hydroiodic acid
HCN	Hydrocyanic acid
H_2S	Hydrosulfuric acid

Common acids that don't contain oxygen

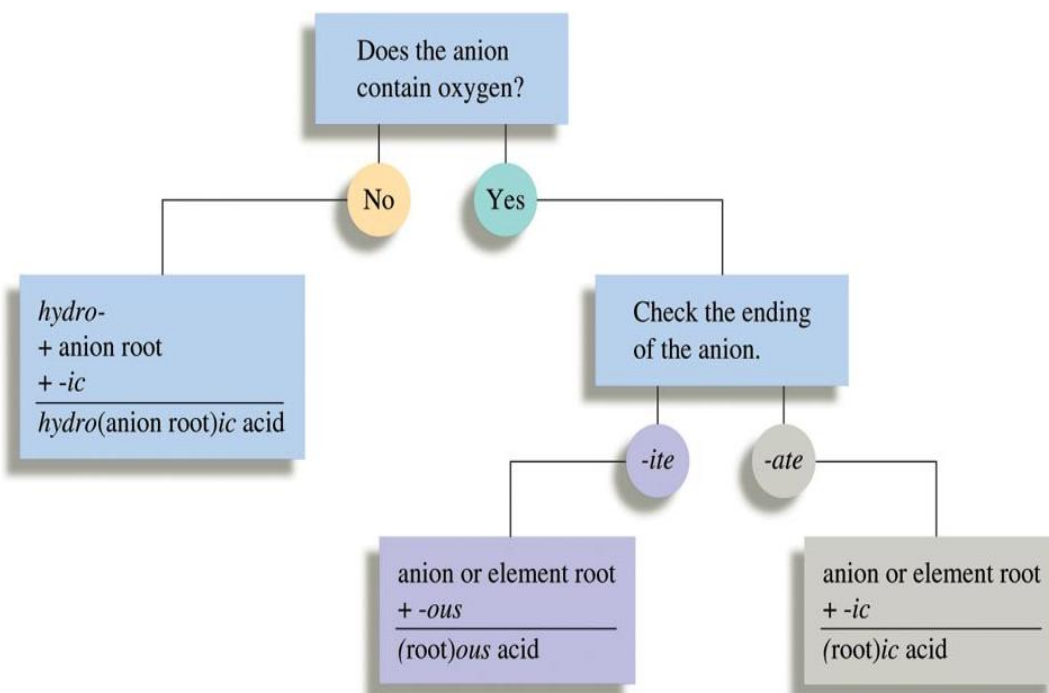

Naming of Acids

- ❖ **Chemical reaction:**

- a) A chemical reaction is a process in which one or more substances are changed into one or more new substances.
- b) All chemical reactions have two parts: Reactants (the substances you start with) and Products (the substances you end up with). E.g. Carbon and oxygen reacts to produce carbon dioxide;
 $Carbon + Oxygen \rightarrow Carbon\ dioxide$

c) **Types of chemical reactions:**

Reaction type	Explanation	General formula
Combination	Two or more compounds combine to form one compound.	$A + B \rightarrow AB$
Decomposition	The opposite of a combination reaction – a complex molecule breaks down to make simpler ones.	$AB \rightarrow A + B$
Precipitation	Two solutions of soluble salts are mixed, resulting in an insoluble solid (precipitate) forming.	$A + \text{soluble salt B} \rightarrow \text{precipitate} + \text{soluble salt C}$
Neutralization	An acid and a base reaction with each other. Generally, the product of this reaction is a salt and water.	$\text{Acid} + \text{salt} \rightarrow \text{salt} + \text{water}$
Combustion	Oxygen combines with a compound to form carbon dioxide and water. These reactions are exothermic, meaning they give off heat.	$A + O_2 \rightarrow H_2O + CO_2$
Displacement	One element trades places with another element in the compound.	$A + BC \rightarrow AC + B$

• **Chemical equation:**

- Chemical equation is the symbolic representation of a chemical reaction.
E.g. Copper reacts with chlorine to form copper (II) chloride; $Cu_{(s)} + Cl_{2(g)} \rightarrow CuCl_{2(s)}$
- Reactants and products may be Solids (s), Liquids (l), Gases (g), Solutions (aq).
- The symbols used to indicate the state of the solids, liquids, gases or solutions are called **State Symbols**. E.g. $C_{(s)} + O_{2(g)} \rightarrow CO_{2(g)}$

• **Balanced Chemical Equations:**

- When the numbers of different atoms are the same on both sides, an equation is said to be balanced. E.g. $2H_{2(g)} + O_{2(g)} \rightarrow 2H_2O_{(l)}$
- An equation which is not balanced is not correct.

c) **How to write balanced Chemical Equations:**

- Write the equation in words.
E.g. Calcium burns in chlorine to form a solid calcium chloride.
- Write the equation using symbols and formula.
Calcium + Chlorine \rightarrow Calcium Chloride; $Ca + Cl_2 \rightarrow CaCl_2$
- Make sure all the formulae are correct.
- Check that the equation is balanced for each type of atom.
Left side (Ca: 1 Cl: 2), Right side (Ca: 1 Cl: 2), so the equation is balanced.
- Make sure you do not change any formula.
- Add the state symbols.
 $Ca_{(s)} + Cl_{2(g)} \rightarrow CaCl_{2(s)}$

d) **Rules for balancing chemical equations:**

- Write the correct formulas for all the reactants and products.
- Count the number of atoms of each type on both sides.
- Check to make sure it is balanced.

- 4) Change the numbers in front of the formulas to make the number of atoms of each element the same on both sides of the equation.
- 5) 6. Do not change the subscripts.

Example 1:

Ethane + Oxygen → Carbon Dioxide + Steam

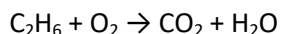

Step 1: Balance C atom, put 2 before CO₂

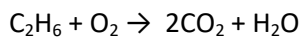

Step 2: Balance H atom, put 3 before H₂O

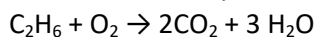

Step 3: Balance O atom, put 7/2 before O₂

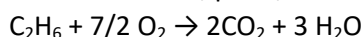

Step 4: Multiply the whole equation by 2 we get the balanced equation is

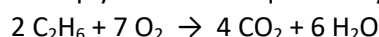

❖ **Mole Concept:**

- It is a unit for substance. It is the amount of substance containing the same number of particles (atoms, molecules or ions), as there are atoms in exactly 12.00 grams of C-12
- **1 mole** of any substance contains 6.02×10^{23} particles.
 - a) 1 mole = $N_A = 6.02 \times 10^{23}$, Avogadro's number (N_A).
 - b) $N = n \times N_A$, N = number of particles (atoms), n = number of moles, N_A = Avogadro's constant
 - c) **E.g 1:** 1 mole of hydrogen atoms has a mass of 1 gram and contains 6×10^{23} atoms or molecules.
E.g 2: 2 moles of oxygen atoms have a mass of 32 grams and contain 12×10^{23} atoms or molecules.
- **Atomic mass** is the mass of an atom in atomic mass units (amu). E.g. $^1\text{H} = 1.008$ amu
 - a) Relative Atomic Mass (**RAM**) = $\frac{\text{Mass of one atom of element (m)}}{\text{Number of moles (n)}}$ g/mole or amu
 - b) Actual masses of atoms are very small. E.g. hydrogen actual mass is 1.66×10^{-24} g, but the relative atomic mass (RAM) is 1.008 amu.
 - c) Relative molecular mass (RMM) is the sum of relative atomic masses (RAM) of the atoms.
 - d) **RMM** = $\frac{\text{Mass of one molecule of the compound (m)}}{\text{Number of moles (n)}}$ g/mole or amu
E.g. **RMM of SO₂:** 1S=32.07 amu, 2O=2*16=32 amu, **RMM of SO₂=64.07** amu.
- **Molar Volume:**
 - a) Volume occupied by 1 mole of any gas at standard temperature and pressure (s.t.p) is always the same and equals to 22.4 dm^3 .
 - b) **Molar Volume = $22.4 \text{ dm}^3/\text{mole}$**
 - c) E.g. the amount of moles presents in the volumes 12.4 dm^3 of helium gas at s.t.p.

1 mol	→	22.4 dm^3	Moles of Helium = $(12.4 \text{ dm}^3 \times 1 \text{ mol}) / 22.4 \text{ dm}^3$
x mol of He	→	12.4 dm^3	= 0.554 mol

❖ **Concentration:**

- The concentration of a solution is the amount of solute present in a given quantity of solvent or solution.
- **A solution** is a homogenous mixture of 2 or more substances (Solvent + Solute).
- **A solute** is the substance that dissolved into a solvent and it presents in the smaller amount.
- **A solvent** is the substance that dissolved the solute substance and it presents in the larger amount.
- **E.g.** Solvent (N_2) + Solute (O_2 , Ar, CO_2) → Solution (Air_(g))
 Solvent (H_2O) + Solute (CO_2 , Sugar) → Solution (Soft drink_(l))

• **Types of Solutions:**

Component 1	Component 2	State of Resulting Solution	Examples
Gas	Gas	Gas	Air
Gas	Liquid	Liquid	Soda water (CO_2 in water)
Gas	Solid	Solid	H_2 gas in palladium
Liquid	Liquid	Liquid	Ethanol in water
Solid	Liquid	Liquid	NaCl (salt) in water
Solid	Solid	Solid	Brass (Cu/Zn), Solder (Sn/Pb)

• **Methods express the concentration:**

1) **Molarity:**

- It is the number of moles of solutes dissolved in one liter of solution.
- Symbol used for molarity is **M**.
- Molarity (M)** = $\frac{\text{No of moles of solutes (mol)}}{\text{Volume of solution (dm}^3\text{)}} = \frac{\text{mole of solute}}{\text{liters of solution}} = \frac{n}{V} \text{ mol/dm}^3$

E.g.1 What is the concentration of a solution which is made by dissolving 0.5 mole of NaOH in 200cm^3 of solution?

No of moles of NaOH $n = 0.5$ mole

Volume of solution (V) = 200cm^3

$1 \text{ dm}^3 = 1000 \text{ cm}^3$

$200\text{cm}^3 = 200 / 1000 = 0.2 \text{ dm}^3$

Now apply the formula for concentration

$$M = n/V$$

$$M = 0.50 \text{ mole} / 0.20 \text{ dm}^3 = \mathbf{2.5M}$$

E.g.2 Calculate the concentration of 6.3g of silver nitrate ($AgNO_3$) in 0.05 dm^3 water.

First find the no of moles of $AgNO_3$

$$n = m/RMM$$

$$RMM = 107.9 + 14 + 3 \times 16 = 170 \text{ g/mol}$$

$$= 6.3\text{g} / (170 \text{ g/mol}) = 0.037 \text{ mol}$$

Now apply the formula for concentration

$$M = n/V$$

$$= 0.037 \text{ mol} / 0.05 \text{ dm}^3 = 0.74 \text{ mol /dm}^3$$

$$= \mathbf{0.74M}$$

- d) **Molar solution** is that solution which contains 1 mole of solute dissolved in 1 dm³ or 1 liter of solvent.
- e) **Dilution** is making a less concentrated solution from a more concentrated solution by Adding Solvent.

2) **Molality:**

- a) It is the number of moles of solutes dissolved in one Kg of solvent.
- b) Symbol used for molality is **m**

$$c) \text{ Molality (m)} = \frac{\text{No of moles of solutes (mol)}}{\text{Mass of solvent (Kg)}} = \frac{n}{m} \text{ mol/Kg}$$

E.g. calculate the molality of a solution containing 37.0g of HCl in 63g H₂O.

No of moles of HCl (n)=37.0g /36.46=1.01 mol

Mass of solvent (kg) (m)= 63g/1000=0.063 kg

$$m = n/m(Kg)$$

m=1.01 mol/0.063 kg=**16 mol/ kg**

- d) **Molal solution** is that solution which contains 1 mole of solute dissolved in 1 Kg of solvent.

❖ **Solubility:**

- It is the property of a solute to dissolve in a given amount of solvent to form a solution at a specified temperature.
- Solubility value is different for different temperatures.
- The solubility of a substance depends on the solvent, temperature and pressure.
-

• **Types of solutions:**

- 1) **Saturated:** The solvent is holding maximum amount of solute as it can at a given temperature.
- 2) **Unsaturated:** The solution is holding less than maximum amount of solute at a certain temperature
- 3) **Supersaturated:** The solution is holding more than maximum amount of solute a certain temperature.

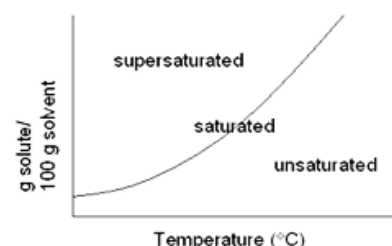
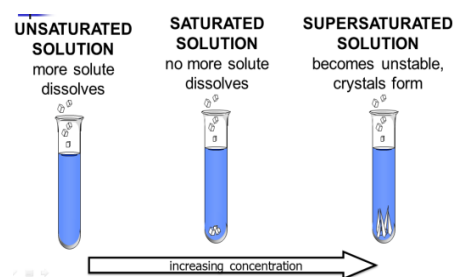

• **Effect of Temperature on solubility:**

- a) Usually solubility of solid increases with increase in temperature.
- b) Solubility of the gases decreases with increase in temperature.

CHAPTER 8

CHAPTER 8

Mathematics

8.1 Formulas

1. π radians = **180°**

2. Radian–Degree Conversion Formulas:

a) Basic proportion: $\frac{\theta_{deg}}{180^\circ} = \frac{\theta_{rad}}{\pi rad}$

b) Radians to degrees: $\theta_{deg} = \frac{180^\circ}{\pi rad} \theta_{rad}$, Degrees to radians: $\theta_{rad} = \frac{\pi rad}{180^\circ} \theta_{deg}$

3. **60'** (minutes) = **1°** (degree)

4. **60"** (seconds) = **1'** (minute)

5. **1'** (minute) = $\left(\frac{1}{60}\right)^\circ$

6. **1"** (second) = $\left(\frac{1}{60 \times 60}\right)^\circ = \left(\frac{1}{3600}\right)^\circ$

7. **Trigonometric functions:** $\sin x, \cos x, \tan x, \operatorname{cosec} x, \sec x, \text{ and } \cot x$

8. **Inverse trigonometric functions:** $\sin^{-1} x, \cos^{-1} x, \tan^{-1} x, \operatorname{cosec}^{-1} x, \sec^{-1} x, \text{ and } \cot^{-1} x$

9. **Trigonometric functions of complementary angles ($90^\circ - x$) or $\left(\frac{\pi}{2} - x\right)$**

- $\sin(90^\circ - x) = \cos x$
- $\cos(90^\circ - x) = \sin x$
- $\tan(90^\circ - x) = \cot x$
- $\operatorname{cosec}(90^\circ - x) = \sec x$
- $\sec(90^\circ - x) = \operatorname{cosec} x$
- $\cot(90^\circ - x) = \tan x$

10. **Trigonometric functions of negative angles:**

- $\sin(-x) = -\sin x$
- $\cos(-x) = \cos x$
- $\tan(-x) = -\tan x$
- $\operatorname{cosec}(-x) = -\operatorname{cosec} x$
- $\sec(-x) = \sec x$
- $\cot(-x) = -\cot x$

11. **Trigonometric Table of some special angles :**

x Tri fn	(0 rad), 0°	$\left(\frac{\pi}{6} \text{ rad}\right), 30^\circ$	$\left(\frac{\pi}{4} \text{ rad}\right), 45^\circ$	$\left(\frac{\pi}{3} \text{ rad}\right), 60^\circ$	$\left(\frac{\pi}{2} \text{ rad}\right), 90^\circ$
$\sin x$	0	$\frac{1}{2}$	$\frac{1}{\sqrt{2}}$	$\frac{\sqrt{3}}{2}$	1
$\cos x$	1	$\frac{\sqrt{3}}{2}$	$\frac{1}{\sqrt{2}}$	$\frac{1}{2}$	0
$\tan x$	0	$\frac{1}{\sqrt{3}}$	1	$\sqrt{3}$	∞

12. Note: **$\cot 90^\circ = 0$, $\operatorname{cosec} 0^\circ = \infty$, $\sec 90^\circ = \infty$, $\cot 0^\circ = \infty$**

13. **Trigonometric Basic Identities:**

<ul style="list-style-type: none"> • $\sin^2 x + \cos^2 x = 1$ • $1 - \sin^2 x = \cos^2 x$ • $1 - \cos^2 x = \sin^2 x$ 	<ul style="list-style-type: none"> • $1 - \cos 2x = 2 \sin^2 x$ • $1 + \cos 2x = 2 \cos^2 x$
<ul style="list-style-type: none"> • $1 + \tan^2 x = \sec^2 x$ • $\sec^2 x - 1 = \tan^2 x$ • $\sec^2 x - \tan^2 x = 1$ 	<ul style="list-style-type: none"> • $1 + \cot^2 x = \operatorname{cosec}^2 x$ • $\operatorname{cosec}^2 x - 1 = \cot^2 x$ • $\operatorname{cosec}^2 x - \cot^2 x = 1$

14. Special Note!

<ul style="list-style-type: none">• $\tan x = \frac{\sin x}{\cos x}$• $\cot x = \frac{\cos x}{\sin x} = \frac{1}{\tan x}$• $\operatorname{cosec} x = \frac{1}{\sin x}$• $\sec x = \frac{1}{\cos x}$
--

15. Trigonometric Sum/Difference Identities:

<ul style="list-style-type: none">• $\sin(A + B) = \sin A \cos B + \cos A \sin B$• $\sin(A - B) = \sin A \cos B - \cos A \sin B$
<ul style="list-style-type: none">• $\cos(A + B) = \cos A \cos B - \sin A \sin B$• $\cos(A - B) = \cos A \cos B + \sin A \sin B$
<ul style="list-style-type: none">• $\tan(A + B) = \frac{\tan A + \tan B}{1 - \tan A \tan B}$• $\tan(A - B) = \frac{\tan A - \tan B}{1 + \tan A \tan B}$

16. Double angle Identities:

<ul style="list-style-type: none">• $\sin 2A = 2 \sin A \cos A$
<ul style="list-style-type: none">• $\cos 2A = \cos^2 A - \sin^2 A$• $\cos 2A = 2\cos^2 A - 1$• $\cos 2A = 1 - 2\sin^2 A$
<ul style="list-style-type: none">• $1 - \cos 2A = \sin^2 A$• $1 + \cos 2A = 2\cos^2 A$
<ul style="list-style-type: none">• $\tan 2A = \frac{2\tan A}{1 - \tan^2 A}$

17. Triple angle Identities:

<ul style="list-style-type: none">• $\sin 3A = 3 \sin A - 4 \sin^3 A$
<ul style="list-style-type: none">• $\cos 3A = 4 \cos^3 A - 3 \cos A$

18. Sum to product identities:

<ul style="list-style-type: none">• $\sin C + \sin D = 2 \sin \frac{C+D}{2} \cos \frac{C-D}{2}$• $\sin C - \sin D = 2 \cos \frac{C+D}{2} \cos \frac{C-D}{2}$• $\cos C + \cos D = 2 \cos \frac{C+D}{2} \cos \frac{C-D}{2}$• $\cos C - \cos D = -2 \sin \frac{C+D}{2} \sin \frac{C-D}{2}$
--

19. Product to Sum identities:

<ul style="list-style-type: none">• $2 \sin A \cos B = \sin(A + B) + \sin(A - B)$• $2 \cos A \sin B = \sin(A + B) - \sin(A - B)$• $2 \cos A \cos B = \cos(A + B) + \cos(A - B)$• $2 \sin A \sin B = \cos(A - B) - \cos(A + B)$

20. Algebraic Identities:

a) $(a + b)^2 = a^2 + 2ab + b^2$

b) $(a - b)^2 = a^2 - 2ab + b^2$

c) $(a + b)(a - b) = a^2 - b^2$

d) $(a - b)^3 = a^3 - 3a^2b + 3ab^2 - b^3$

e) $(a + b)^3 = a^3 + 3a^2b + 3ab^2 + b^3$

f) $(a + b)(a^2 - ab + a^2) = a^3 + b^3$

g) $(a - b)(a^2 + ab + a^2) = a^3 - b^3$

21. Indices formulas:

a) $a^m a^n = a^{m+n}$

b) $\frac{a^m}{a^n} = a^{m-n}$

c) $(a^m)^n = a^{mn}$

d) $a^{\frac{m}{n}} = \sqrt[n]{a^m}$, The symbol $\sqrt{\quad}$ is called a **radical**, **n** is called the **index**, and **a** is called the **radicand**

e) $a^{-m} = \frac{1}{a^m}$

f) $a^0 = 1$

22. Logarithmic rules:

a) $\log_a x + \log_a y = \log_a xy$

b) $\log_a x - \log_a y = \log_a \frac{x}{y}$

c) $\log_a x^n = n \times \log_a x$

d) $\log 1 = 0$

e) $\log_a a = 1$

f) $\log x = \log_{10} x$

g) $\ln e = 1$

h) $\ln x = \log_e x$

23. Exponential form of hyperbolic functions:

a) $\cosh(at) = \frac{e^{at} + e^{-at}}{2}$

b) $\sinh(at) = \frac{e^{at} - e^{-at}}{2}$

24. Exponential form of trigonometric functions:

a) $\cos(at) = \frac{e^{iat} + e^{-iat}}{2}$

b) $\sin(at) = \frac{e^{iat} - e^{-iat}}{2i}$

25. Limits:

a) $\lim_{x \rightarrow 0} \frac{\sin x}{x} = 1$

b) $\lim_{x \rightarrow 0} \frac{a^x - 1}{x} = \ln a$

c) $\lim_{x \rightarrow 0} \frac{e^x - 1}{x} = 1$

d) $\lim_{x \rightarrow a} \frac{x^x - a^n}{x - a} = n a^{n-1}$

26. Partial Fraction Rules:

- a) $\frac{A \pm B}{C} = \frac{A}{C} \pm \frac{B}{C}, C \neq 0$
- b) $\frac{b-a}{(x+a)(x+b)} = \frac{1}{x+a} - \frac{1}{x+b}, x+a \neq 0, x+b \neq 0$
- c) $\frac{b-a}{(x-a)(x-b)} = \frac{1}{x-a} - \frac{1}{x-b}, x-a \neq 0, x-b \neq 0$
- d) $\frac{a \pm b}{ab} = \frac{1}{b} \pm \frac{1}{a}, a \neq 0, b \neq 0$

27. Quadratic Formula:

If $ax^2 + bx + c = 0, a \neq 0$ (Quadratic Equation) then: $x = \frac{-b \pm \sqrt{b^2 - 4ac}}{2a}$

28. Equations of some important curves:

- a) Equation of the circle with center (a, b) and radius r is $(x-a)^2 + (y-b)^2 = r^2$
- b) Equation of the circle with center origin and radius r is $x^2 + y^2 = r^2$
- c) Equation of ellipse is $\frac{x^2}{a^2} + \frac{y^2}{b^2} = 1$, where a and b are constants.
- d) Equation of a parabola is $y = ax^2 + bx + c$, where a and b and c are constants.
- e) Equation of the hyperbola is $\frac{x^2}{a^2} - \frac{y^2}{b^2} = 1$, where a and b are constants.

29. Pythagoras' theorem

The square of the hypotenuse is equal to the sum of the squares of the other two sides. **pythagoras' equation:** $c^2 = a^2 + b^2$

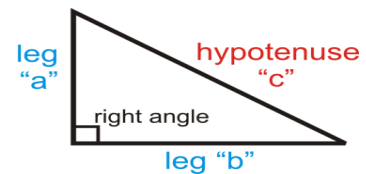

30. Right triangle definition

$$\begin{aligned} \sin \theta &= \frac{\text{opposite}}{\text{hypotenuse}} & \csc \theta &= \frac{\text{hypotenuse}}{\text{opposite}} = \frac{1}{\sin \theta} \\ \cos \theta &= \frac{\text{adjacent}}{\text{hypotenuse}} & \sec \theta &= \frac{\text{hypotenuse}}{\text{adjacent}} = \frac{1}{\cos \theta} \\ \tan \theta &= \frac{\text{opposite}}{\text{adjacent}} & \cot \theta &= \frac{\text{adjacent}}{\text{opposite}} = \frac{1}{\tan \theta} \end{aligned}$$

$0^\circ < \theta < 90^\circ$

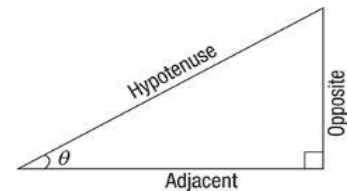

31. Unit circle definition

$$\begin{aligned} \sin \theta &= \frac{y}{1} = y & \csc \theta &= \frac{1}{y} \\ \cos \theta &= \frac{x}{1} = x & \sec \theta &= \frac{1}{x} \\ \tan \theta &= \frac{y}{x} & \cot \theta &= \frac{x}{y} \end{aligned}$$

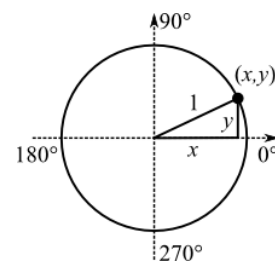

❖ Angles and Their Measure:

- **Angles:** It is formed by rotating initial side of the angle around terminal side of the angle.
- A counterclockwise rotation produces a positive angle, and a clockwise rotation produces a negative angle.

Angle θ or angle PVQ or $\angle V$

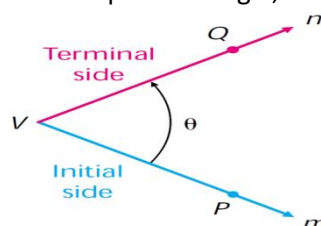

- **Angles and rotation:**

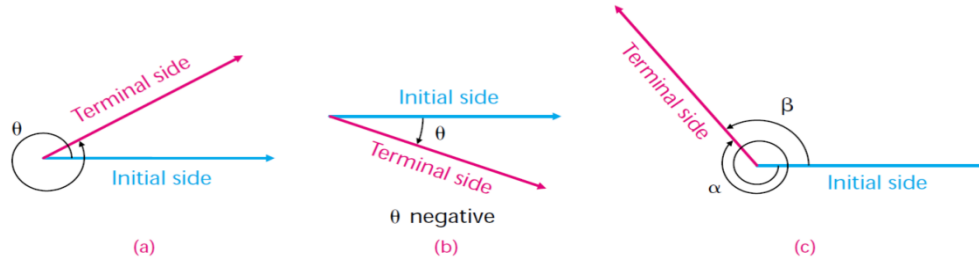

- **Angles in standard positions:**

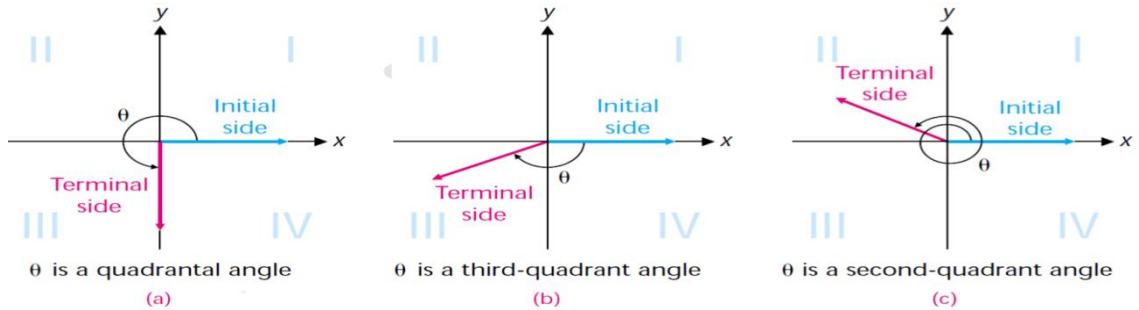

- **Types of angles**

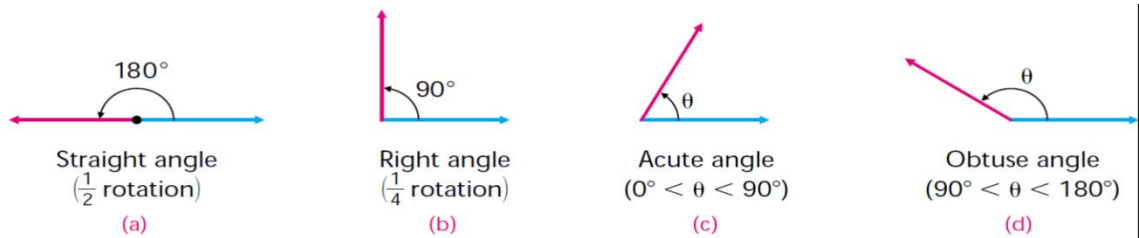

- **Degree Measure:** The two most commonly used units for angle measure are degree & radian.

- Angle formed by one complete rotation is said to have a measure of 360 degrees (360°).
- Angle formed by $\frac{1}{360}$ of a complete rotation is said to have a measure of 1 degree (1°).
- Degree measure is used in engineering, surveying & navigation.
- Convert from Decimal degrees (**DD**) to degrees- minutes-seconds (**DMS**) and vice versa:
 - E.g.1 Convert $21^\circ 47' 12''$ to DD form.
Solution: $21^\circ 47' 12'' = \left(21 + \frac{47}{60} + \frac{12}{3600}\right) = 21.787^\circ$
 - E.g.2 Convert 105.183° to DMS form.
Solution: $105.183^\circ = 105^\circ(0.183 \times 60)' = 105^\circ 10.98' = 105^\circ 10' (0.98 \times 60)'' = 105^\circ 10' 59''$

- **Radian Measure:**

- Length of arc s of a circle: $s = r\theta$
Where, r , radius of the circle, θ , The angle subtended by arc, and it should be measured in radians.

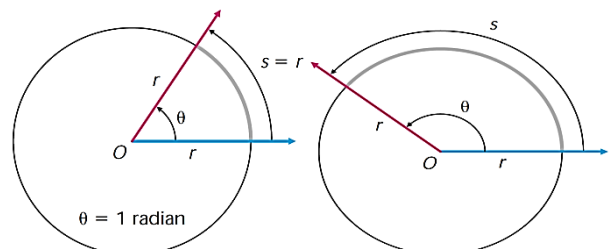

- If $s = r$, then $\theta = r/r = 1$ radian
- Radian measure is used in mathematical developments, scientific work & engineering applications.
- Engineering: A belt connects a pulley of 2-inch radius with a pulley of 5-inch radius. If the larger pulley turns through 10 radians, through how many radians will the smaller pulley turn?

Solution: For the larger pulley: $s = r\theta = (5)(10) = 50$ inches

For the smaller pulley: $\theta = \frac{s}{r} = \frac{50}{2} = 25$ radians

❖ **Algebra & Real Numbers:**

• **Sets:**

- a) They are a collection of objects with the important property.
- b) Each object in a set is called **an element** or **member** of the set.
- c) $a \in A$ means "a is an element of set A" E.g. $3 \in \{1, 3, 5\}$
- d) $a \notin A$ means "a is not an element of set A" E.g. $2 \notin \{1, 3, 5\}$
- e) A set is finite if the number of elements in the set can be counted and infinite if there is no end in counting its elements.
- f) A set is **empty or null set** if it contains no elements, and is denoted by \emptyset
- g) If each element of set A is also an element of set B, we say that A is a **subset** of set B, and we write $A \subset B$ e.g. $\{1, 5\} \subset \{1, 3, 5\}$
- h) Since the empty set \emptyset has no elements, every element of \emptyset is also an element of any given set. Thus, the empty set is a subset of every set. E.g. $\emptyset \subset \{1, 3, 5\}$
- i) If two sets A and B have exactly the same elements, the sets are said to be **equal**, and we write $A = B$ $\{4, 2, 6\} = \{6, 4, 2\}$
- j) Union: $A \cup B$: The combining all the elements of A and B. E.g. $\{1,2\} \cup \{2,3\} = \{1,2,3\}$
- k) Intersection: $A \cap B$:The set of elements of A that are also in B. E.g. $\{1,2\} \cap \{2,3\} = \{2\}$

• **The set of Real Numbers:**

- a) It is any number that has a decimal representation.
- b) Real numbers and important subsets:

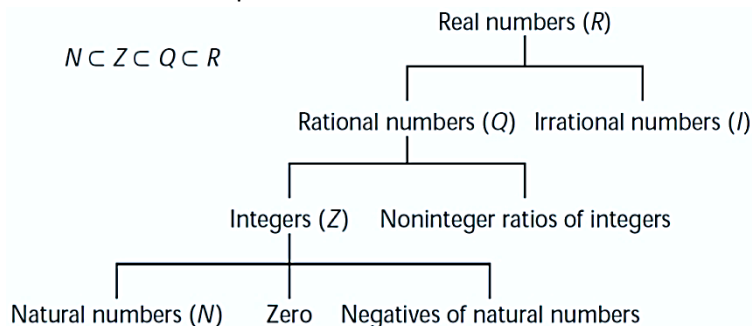

c) **The Set of Real Numbers:**

Symbol	Name	Description	Examples
N	Natural numbers	Counting numbers (also called positive integers)	1, 2, 3, ...
Z	Integers	Natural numbers, their negatives and 0	..., -2, -1, 0, 1, 2, ...
Q	Rational numbers	Numbers that can be represented as a/b , where a and b are integers and $b \neq 0$; decimal representations are repeating or terminating	-4, 0, 1, 25, $\frac{-3}{5}$, $\frac{2}{3}$, 3.67, $-0.33\overline{3}$, $5.27\overline{27}$
I	Irrational numbers	Numbers that can be represented as nonrepeating and nonterminating decimal numbers	$\sqrt{2}$, π , $\sqrt[3]{7}$, 1.4142.., 2.718...
R	Real numbers	Rational numbers and irrational numbers	

• **Natural number exponents:**

- a) For **n** a natural number and **a** any real number:
 $a^n = a \times a \times \dots \times a$, *n factors of a*, E.g. $2^4 = 2 \times 2 \times 2 \times 2$ 4 factors of 2

• **Polynomials:**

- a) They are involving only the operations of addition, subtraction, multiplication, and rising to natural number powers on variables and constants.
- b) Examples of Polynomials and Nonpolynomials:

- 1) Polynomials in one variable: $x^2 - 3x + 2$, $6x^3 - \sqrt{2}x - \frac{1}{3}$
- 2) Polynomials in several variables: $3x^2 - 2xy + y^2$, $4x^3y^2 - \sqrt{3}xy^2z^5$
- 3) Nonpolynomials: $\sqrt{2}x - \frac{3}{x} + 5$, $\frac{x^2-3x+2}{x-3}$, $\sqrt{x^2 - 3x + 1}$

c) classifying polynomials by degree:

- 1) Single-term polynomial called a **Monomial**: E.g. $\frac{5}{2}x^2y^3$
- 2) Two-term polynomial called a **Binomial**: E.g. $x^3 + 4.7$
- 3) Three-term polynomial called a **Trinomial**: E.g. $x^4 - \sqrt{2}x^2 + 9$

d) Polynomials: Factoring:

- 1) A factor of a number is one of two or more numbers whose product is the given number.
- 2) E.g. $30 = 2 \times 3 \times 5$ 2, 3, and 5 are each factors of 30.
 $x^2 - 4 = (x - 2)(x + 2)$, $(x - 2)$ & $(x + 2)$ are each factors of $x^2 - 4$

❖ Long division

- The number to be divided into is known as the **dividend**
- The number which divides the other number is known as the **divisor**

$$425 \div 25$$

↖ ↙
dividend divisor

Steps	Long division	Calculations	Explanations
Step 1	$25 \overline{)425}$	$4 \div 25 \approx 0$	The first digit of the dividend (4) is divided by the divisor. Any remainders are ignored.
Step 2	$25 \overline{)425}$ $\begin{array}{r} 0 \\ 25 \times 0 = 0 \\ \hline 0 \end{array}$	$25 \times 0 = 0$	The result number is placed at top and it multiplied by the divisor. The result is placed under the number divided into
Step 3	$25 \overline{)425}$ $\begin{array}{r} 0 \\ 0 \\ \hline 4 \end{array}$	$4 - 0 = 4$	Now we subtract the bottom number from the top number.
Step 4	$25 \overline{)425}$ $\begin{array}{r} 01 \\ 25 \times 1 = 25 \\ \hline 02 \end{array}$	$42 \div 25 \approx 1$	Bring down the next digit of the dividend and Divide this number by the divisor. The result number is placed at the top. Any remainders are ignored.
Step 5	$25 \overline{)425}$ $\begin{array}{r} 01 \\ 25 \times 1 = 25 \\ \hline 02 \\ 25 \end{array}$	$25 \times 1 = 25$	The answer from the above operation is multiplied by the divisor. The result is placed under the last number divided into.
Step 6	$25 \overline{)425}$ $\begin{array}{r} 01 \\ 25 \times 1 = 25 \\ \hline 02 \\ 25 \\ \hline 17 \end{array}$	$42 - 25 = 17$	Now we subtract the bottom number from the top number.
Step 7	$25 \overline{)425}$ $\begin{array}{r} 017 \\ 25 \times 7 = 175 \\ \hline 02 \\ 25 \\ \hline 175 \end{array}$	$175 \div 25 = 7$	Bring down the next digit of the dividend and Divide this number by the divisor. The result number is placed at the top. Any remainders are ignored.
Step 8	$25 \overline{)425}$ $\begin{array}{r} 017 \\ 25 \times 7 = 175 \\ \hline 02 \\ 25 \\ \hline 175 \\ 175 \end{array}$	$25 \times 7 = 175$	The answer from the above operation is multiplied by the divisor. The result is placed under the number divided into.
Step 9	$25 \overline{)425}$ $\begin{array}{r} 017 \\ 25 \times 7 = 175 \\ \hline 02 \\ 25 \\ \hline 175 \\ 175 \\ \hline 000 \end{array}$	$175 - 175 = 0$	Now we subtract the bottom number from the top number.
Step 10			There are no more digits to bring down. The answer must be 17.

❖ **Converting of Decimals and Fractions**

1. Convert Fractions to Decimals by using long division

$$\frac{3}{5} \begin{array}{l} \leftarrow \text{numerator} \\ \leftarrow \text{denominator} \end{array}$$

- The form **a/b** is called a **fraction**
- The number to be divided into is known as the **numerator**.
- The number which divides the other number is known as the **denominator**.

Steps	Long division	Calculations	Explanations
Step 1	$5 \overline{)3}$		We convert fraction into long division form.
Step 2	$5 \overline{)3.0}$		Add the decimal point after numerator and put the decimal point in the answer. Then add zero after the numerator decimal point.
Step 3	$5 \overline{)3.0} \begin{array}{r} .6 \\ \hline \end{array}$	$30 \div 5 = 6$	The answer from the above operation is divided into the denominator. The result number is placed at the top. Any remainders are ignored.
Step 4	$5 \overline{)3.0} \begin{array}{r} .6 \\ \hline 30 \\ \hline \end{array}$	$6 \times 5 = 30$	Now we multiply the top number into the denominator. The result number is placed under the numerator.
Step 5	$5 \overline{)3.0} \begin{array}{r} .6 \\ \hline 30 \\ \hline 0 \end{array}$	$30 - 30 = 0$	Now we subtract the bottom number from the top number.
Step 6		Answer = 0.6	There are no more digits to bring down. The answer must be 0.6 . If There are more digits to bring down, add another zero after the numerator decimal point until become no digits at the down.

2. Convert Decimals to Fractions by using long division







- If there is one number after the decimal point, then use 10, if there are two then use 100, if there are three then use 1000, etc.

Steps	Calculations	Explanations
Step 1	$\frac{0.75}{1}$	Write down 0.75 divided by 1
Step 2	$\frac{0.75 \times 100}{1 \times 100} = \frac{75}{100}$	Multiply both top and bottom by 100, because there are 2 digits after the decimal point.
Step 3	$\frac{75 \div 5}{100 \div 5} = \frac{15}{20}$	Simplify the fraction by divide both top and bottom by 5
Step 4	$\frac{15 \div 5}{20 \div 5} = \frac{3}{4}$	The answer from the above operation is divided into 5
Step 5	Answer = $\frac{3}{4}$	We cannot simplify the fraction more, so the answer must be $\frac{3}{4}$.

❖ **Mensuration Formula**

Shape/Solid	Perimeter	Area	Volume	Details
Rectangle/Cuboid	$P = 2 \times (l + b)$	$A = l \times b$	$V = lbh$	Length (<i>l</i>), Breath(<i>b</i>), Height (<i>h</i>)
Square/Cube	$P = 4 \times l$	$A = l^2$	$V = l^3$	Length (<i>l</i>)
Triangle/Pyramid	$P = a + b + c$	$A = \frac{1}{2} \times b \times h$	$V = \frac{1}{3}lwh$	Length (<i>l</i>), Base (<i>b</i>), Height (<i>h</i>), Width (<i>w</i>)
Circle/Sphere	$P = 2\pi r$	$A = \pi r^2 / A = 4\pi r^2$	$V = \frac{4}{3}\pi r^3$	Radius (<i>r</i>)
Cylinder	$P = (\pi r + 2h)$	$A = 2\pi rh$	$V = \pi r^2 h$	Radius (<i>r</i>), Height (<i>h</i>)

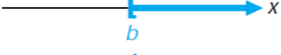
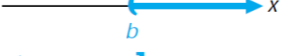
❖ Interval Notation

Interval notation	Inequality notation	Line graph	Type
$[a, b]$	$a \leq x \leq b$		Closed
$[a, b)$	$a \leq x < b$		Half-open
$(a, b]$	$a < x \leq b$		Half-open
(a, b)	$a < x < b$		Open
$[b, \infty)$	$x \geq b$		Closed
(b, ∞)	$x > b$		Open
$(-\infty, a]$	$x \leq a$		Closed
$(-\infty, a)$	$x < a$		Open

❖ Integration

• Rules of Integration

- $\int k f(x) dx = k \int f(x) dx$
- $\int [f(x) \pm g(x)] dx = \int f(x) dx \pm \int g(x) dx$
- If $\int f(x) dx = F(x) + c$, then $\int_a^b f(x) dx = F(b) - F(a)$

• Formulas:

No.	Formula	No.	Formula
1	$\int x^n dx = \frac{x^{n+1}}{n+1} + c$	1+	$\int (ax + b)^n dx = \frac{1}{a} \frac{(ax+b)^{n+1}}{(n+1)} + c$
2	$\int \frac{1}{x} dx = \ln x + c$	2+	$\int \frac{1}{ax+b} dx = \frac{1}{a} \ln(ax + b) + c$
3	$\int e^x dx = e^x + c$	3+	$\int e^{ax+b} dx = \frac{1}{a} e^{ax+b} + c$
4	$\int a^x dx = \frac{a^x}{\ln a} + c$	4+	$\int a^{kx+b} dx = \frac{1}{k} \frac{a^{kx+b}}{\ln a} + c$
5	$\int \sin x dx = -\cos x + c$	5+	$\int \sin(ax + b) dx = -\frac{1}{a} \cos(ax + b) + c$
6	$\int \cos x dx = \sin x + c$	6+	$\int \cos(ax + b) dx = \frac{1}{a} \sin(ax + b) + c$
7	$\int \sec^2 x dx = \tan x + c$	7+	$\int \sec^2(ax + b) dx = \frac{1}{a} \tan(ax + b) + c$
8	$\int \operatorname{cosec}^2 x dx = -\cot x + c$	8+	$\int \operatorname{cosec}^2(ax + b) dx = -\frac{1}{a} \cot(ax + b) + c$
9	$\int \tan x dx = \ln(\sec x) + c$	10	$\int \cot x dx = \ln(\sin x) + c$
11	$\int k dx = kx + c$ (k constant)	12	$\int dx = x + c$
13	$\int \frac{1}{\sqrt{x}} dx = 2\sqrt{x} + c$	13+	$\int \frac{1}{\sqrt{x^2}} dx = -\frac{1}{x} + c$

- $\frac{f'(x)}{f(x)} dx = \ln f(x) + c$
- $\int_a^b f(x) dx$ is the area of the region bounded by the curve $y = f(x)$, the ordinates $x = a$ and $x = b$, and the x -axis

❖ Differentiation

- **Rules of Differentiation:** In the following statements, k is a constant and u, v are functions x

1. If $y = ku$, then $\frac{dy}{dx} = ku'$ **Constant - Function Rule**

2. If $y = u \pm v$, then $\frac{dy}{dx} = u' \pm v'$ **Sum rule**

3. If $y = u \times v$, then $\frac{dy}{dx} = u v' + v u'$ **Product rule**

4. If $y = \frac{u}{v}, v \neq 0$, then $\frac{dy}{dx} = \frac{vu' - uv'}{v^2}$ **Quotient rule**

5. If $y = f[g(x)]$, then $\frac{dy}{dx} = f'[g(x)] g'(x)$ **Chain rule**

- **Formulae**

SN	Function $f(x)$	Derivative $f'(x)$	SN	Function $f(x)$	Derivative $f'(x)$
1	x^n	nx^{n-1}	1+	$(ax + b)^n$	$an(ax + b)^{n-1}$
2	e^x	e^x	2+	e^{ax+b}	ae^{ax+b}
3	a^x (a constant)	$a^x \ln a$	3+	e^{kx+b}	$ka^{kx+b} \ln a$
4	$\sin x$	$\cos x$	4+	$\sin(ax + b)$	$a \cos(ax + b)$
5	$\cos x$	$-\sin x$	5+	$\cos(ax + b)$	$-a \sin(ax + b)$
6	$\tan x$	$\sec^2 x$	6+	$\tan(ax + b)$	$a \sec^2(ax + b)$
7	$\cot x$	$-\operatorname{cosec}^2 x$	7+	$\cot(ax + b)$	$-a \operatorname{cosec}^2(ax + b)$
8	$\ln x$	$\frac{1}{x}$	8+	$\ln(ax + b)$	$a \frac{1}{ax+b}$
9	$\log_a x$	$\frac{1}{x \ln a}$	10	k (k constant)	0
11	x	1	12	$\frac{1}{x}$	$-\frac{1}{x^2}$
13	$\sec x$	$\sec x \tan x$	14	$\operatorname{cosec} x$	$-\operatorname{cosec} x \cot x$
15	\sqrt{x}	$\frac{1}{2\sqrt{x}}$			

- The slope or gradient ' m ' of a curve $y = f(x)$ at the point (x_1, y_1) is $\left. \frac{dy}{dx} \right|_{(x_1, y_1)}$
- Equation of the tangent to the curve $y = f(x)$ at the point (x_1, y_1) is $y - y_1 = m(x - x_1)$
- Equation of the tangent to the curve $y = f(x)$ at the point (x_1, y_1) is $y - y_1 = -\frac{1}{m}(x - x_1)$