

POLYLASE™ MX

Two state-of-the-art lasers in one complete package!

The versatile Polylase MX combines high power 755 nm Alexandrite and 1064 nm Nd:YAG lasers. Great for all skin type hair removal as well as numerous other applications.

DESIGN

- Rapid spot size changes with motorized handpiece zoom lens
- On demand use – no need to wait for warm-up – just turn on and it's ready to go
- Adjustable 10" HD display
- Super quiet

PERFORMANCE & EFFICIENCY

- High-performance dual-wavelength system (755 nm/1064 nm)
- No warm-up
- Unique ultra-short pulse duration for fine hair treatment
- Compressed chilled air cooling provides constant skin cooling and fast treatment speeds

MAXIMIZING BUSINESS POTENTIAL

- No costly consumables and low maintenance costs
- Reduced treatment time due to unsurpassed laser speed and power



POLYLASE AL ALEXANDRITE LASER

EFFICACY, SELECTIVITY AND SPEED

The Polylase AL offers all the advantages of the Alexandrite 755 nm wavelength, which is highly absorbed by melanin, providing superior efficacy for the removal of unwanted hair on light skin types (I-IV). It also effectively treats epidermal pigmented lesions such as age spots, sun spots, birthmarks, and freckles.

With up to 5 pulses/sec and over 120 W of max average power, it is the fastest and most powerful Alexandrite laser available.

ERGONOMIC AND ULTRA LIGHT

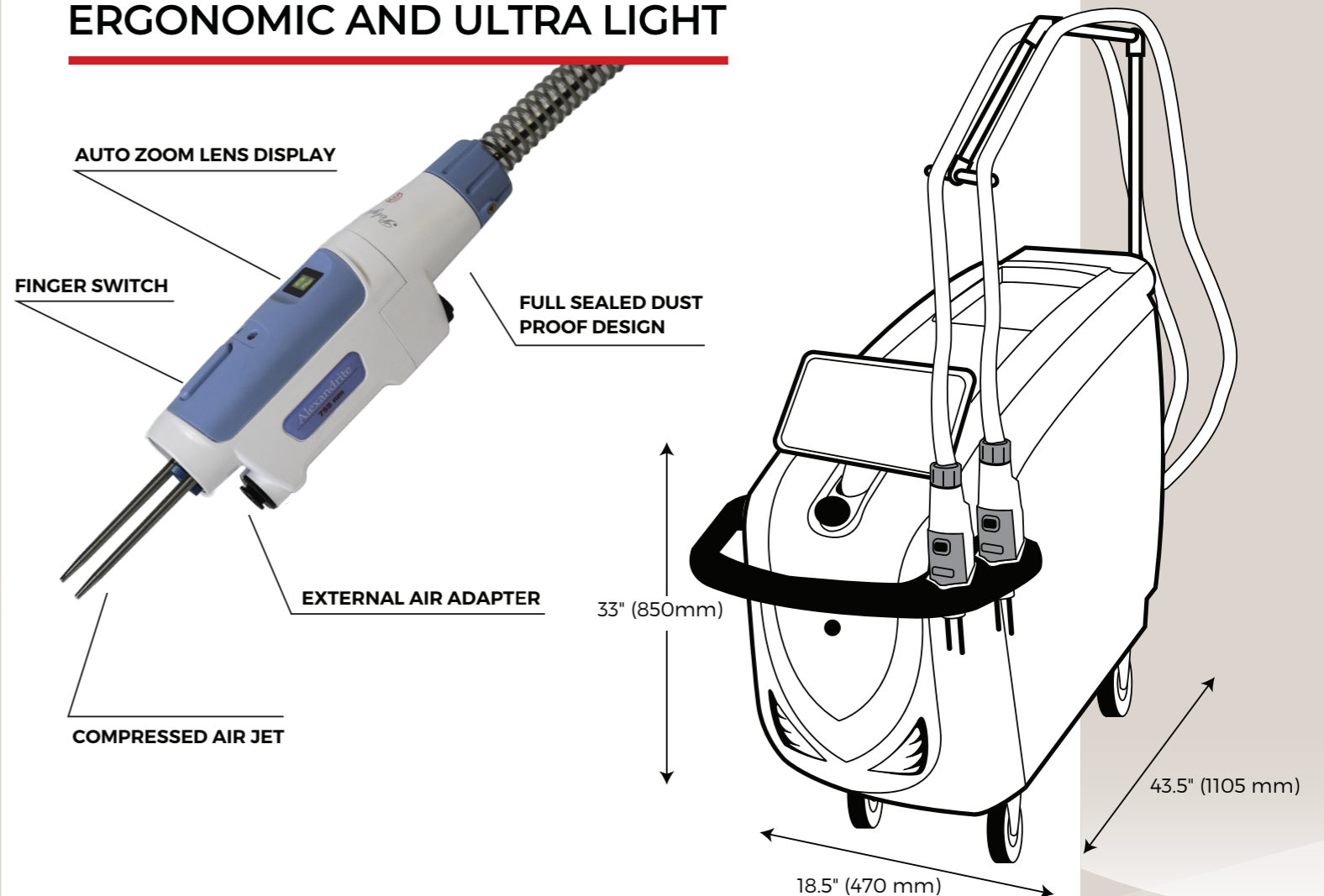

PRODUCT SPECIFICATIONS

Item	Polylase MX / Polylase AL	Polylase MX
Laser Type	Long Pulse Alexandrite Laser	Long Pulse Nd:YAG Laser
Laser Wavelength	755 nm	1064 nm
Max. Energy Per Pulse	75 J	70 J
Laser Pulse Width	0.5-100 ms (user selectable)	0.5-100 ms (user selectable)
Max. Average Power	120 W	120 W
Pulse Repetition Rate	Single Shot to 5 Hz	Single Shot to 10 Hz
Beam Delivery	Optical Fiber, 10 feet (3 m) length	Optical Fiber, 10 feet (3 m) length
Optical Fiber core diameter	1000 µm	1000 µm
Handpiece Spot Size	10 mm, 12 mm or 16 mm dia. (14, 16 and 20 mm optional)	10 mm, 12 mm, or 16 mm dia. Or 2 mm, 3 mm 4 mm in "Vein" mode
Max. Energy Fluence	37.5 J/cm ² @ 16 mm spot size 95.5 J/cm ² @ 10 mm spot size	32.5 J/cm ² @ 16 mm spot size 83 J/cm ² @ 10 mm spot size High (>400 J/cm ²) fluence settings are available with small spot size (vein) objective.
Handpiece Cooling	Compressed chilled air jet	
Dimensions (HxWxL)	33.5" x 18.5" x 43.5" (850 x 470 x 1105 mm)	
Weight	70 kg (155 lbs.)	
Power Requirements	215-240 V single phase ~50/60 Hz, 20 A	

Applications	Polylase MX	Polylase AL
Hair Removal	X	X
Facial and Leg Veins	X	
Vascular Lesions	X	X
Pigmented Lesions	X	X
Facial Wrinkles	X	

Polylase MX™: FDA-cleared technologies and corresponding applications

DDC Technologies, Inc.
311 Woods Avenue, Oceanside, NY 11572
Tel.: (516) 594-1533
Tech. Support: (516) 770-0441
E-mail: sales@ddctech.com
www.ddctech.com



NEW POLYLASE™ MX

Unparalleled Features In Our Super Compact Aesthetic Laser Systems



- ✓ Fast, Reliable, Powerful
- ✓ Compact - Easy to Transport
- ✓ On Demand Use - No Warm-up Required
- ✓ Sealed Handpiece with Fast Motorized Spot Size Change
- ✓ Versatile with Multiple FDA Cleared Applications
- ✓ Low Maintenance and Low Cost of Ownership