



SENTRY

- Performance refractor wall pack - IP65
- Engineered LED optic for superb area lighting
- Durable die cast housing with powder coat finish
- Standard CRI70+, 80+ CRI on request
- UV stabilised polycarbonate refractor
- Quality ~ 120-240V LED converter hard wire or flex-tail option

MODEL	WATTS	OPTIC	COLOUR TEMPERATURE	Lumens	OPTION
SNT	50		3000K	6500	
	70		4000K	9100	
	100		5000K	13000	PE - Photo control
	120			15600	

Geometry

SNT

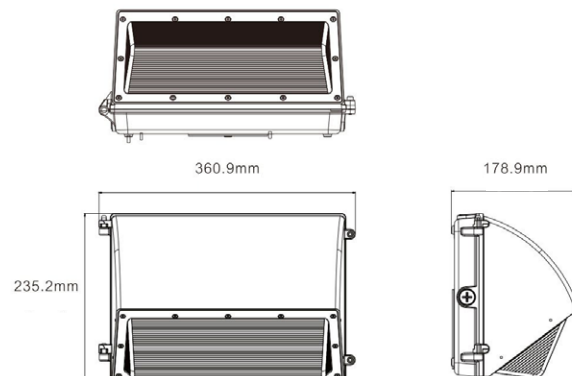

Candela plots

