

PST21D

AC-DC | 150W | 1output



PRODUCTCARD

Electronic | Mechatronic | Optics | Special App

IHR VORTEIL - UNSERE STÄRKEN

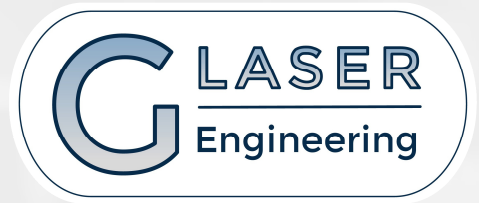

- Europäische Entwicklung
- Europäische Herstellung unter Berücksichtigung von ISO 9001, EN 9100, ISO 14001, ISO 45001
- Kurze Lieferkette
- Kurze Produktionszeiten, da die meisten Bauteile bevorratet werden können.
- Individualisierung nach Kundenwunsch bzw. Anpassung von Formfaktor, Konnektivität und Leistung möglich.
- Standard und ruggedized Varianten
- Modulare Bauweise (mehrere Stromquellen sind System technisch zusammengefasst), Vereinfachung von Konstruktion, Assembling und Service.
- Europäische Normen z.B. EN61000-3-2, EN55022B oder MIL-STD461E CE102, MIL-STD810E
- Alles aus einer Hand:
Design-In, Vertrieb und Abnahme durch das Ingenieurbüro **GLASER Engineering**

PST21D

ACDC 150W Standard product



- 85-264Vac, 47-440Hz Input voltage ranges , PFC
- 100-350 Vdc input voltage operation
- 1 isolated output
- Active very low inrush current limiting circuit
- 165*61*35mm very low profile
- Industrial or ruggedized for hard environment
- Many output configurations available
- Conduction cooled 100°C baseplate

Safety IEC/EN 62368-1, RoHS lead-free-solder compliant



The PST21D, very compact and low profile AC-DC power supply in chassis format, incorporates input filtering, input and output protections, very robust mechanical mounting and connection, optional conformal coating and MIL-STD options required in most of the severe environment for industrial, defense applications. The PSU provides high reliability thanks to the integration of Vicor Corp. modules, high efficiency, input-to-output isolation, soft start and **active very low inrush current limitation**, overtemperature protection and input over/undervoltage lockout. The PSU is configurable in many output voltages from 2V to 48Vdc, other possibilities are even possible as semi-standard versions, they are continuously short-circuit proof. The 100°C baseplate operation allows operation in high temperature environment.

▼ Bloc diagram

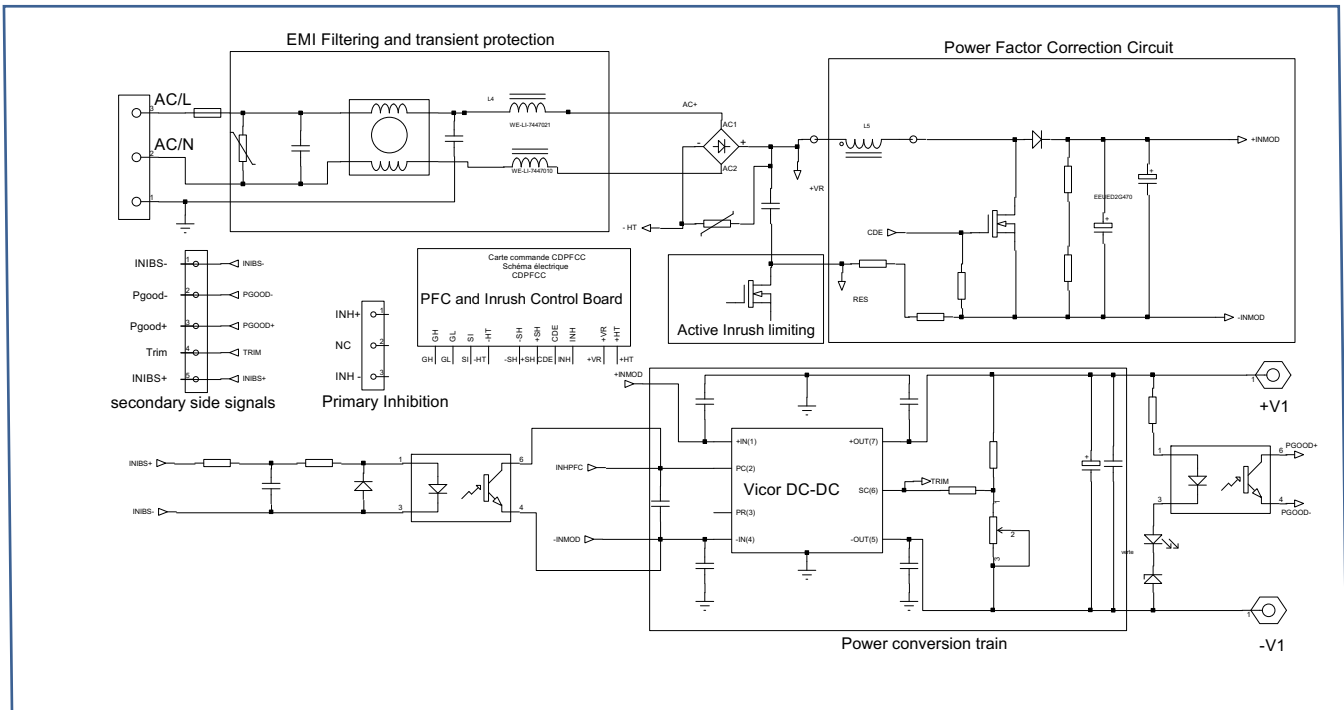

Options Description

MIL-STD ruggedized (-M)

Meet MIL-STD 461E CE102, MIL-STD 1399-300A, MIL-STD810E shock & vibrations. No Laboratory certification.

-40°C operation (-T)

The thermal grade of the Vicor the DC/DC converters used and other components are changed to comply with low ambient temperature.

Conformal coating (-V)

During manufacturing process , when V option is specified, components and pcb are covered with an acrylic coating to address high level of ambient humidity application.

Heatsink (-H, -H1)

-H: a 15 mm heatsink is mounted on the baseplate with longitudinal fins.

-H1: a 15 mm heatsink is mounted on the baseplate with transversal fins.

IP option (-IP)

Full IP65 enclosed mechanical available.

Input

Electrical Input Data

Input					Unit
Characteristics	Conditions	min	typ	max	
Operating input voltage		85		264	Vac
Operating input voltage		100		350	Vdc
Frequency		47	50	440	Hz
Power Factor	230Vac, 50Hz, Pnom.		0,96	0,98	
Input current	At Vin min			2.5	A
No-load input power	At Vin typ		8		W
Peak inrush current	Vin max			5	A
Start-up time				1	s

Input Fuse

A fuse mounted inside the psu protects against damages in case of a failure. The fuse is not user-accessible without opening the unit. In DC mode, reverse polarity at the input is protected and will not cause the fuse to blow .

Model	Fuse type	Rating	Reference
PST21D	schurter	5A	3403.0173

Input Transient Protection

A VDR (Voltage Dependent Resistor) and a common mode input filter form an effective protection against input transients in severe environments.

Power factor curve - PST21D-28150

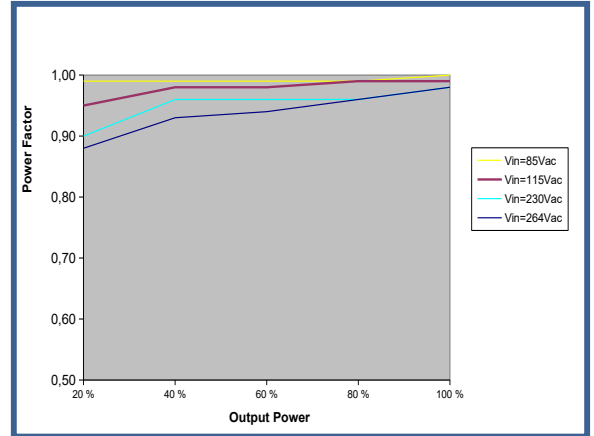

Establishment time curve 115Vac 50Hz - PST21D-28150

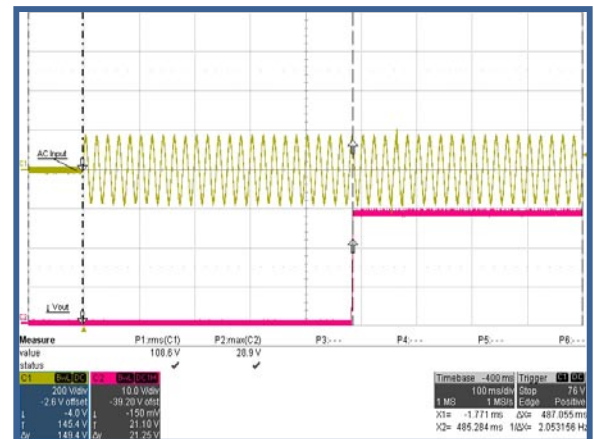

Establishment time curve 230Vac 50Hz - PST21D-28150

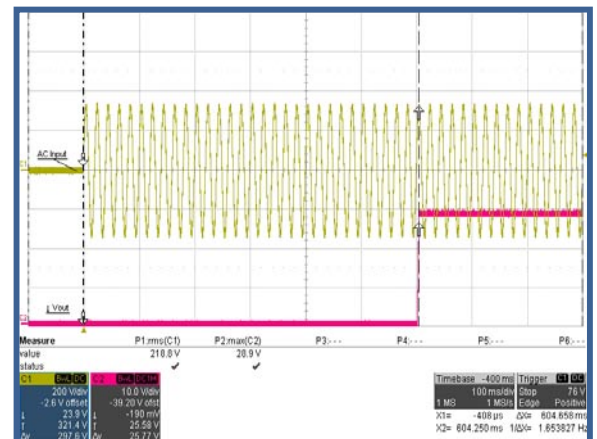

Input power brake at 115Vac 100% Load - PST21D-28150

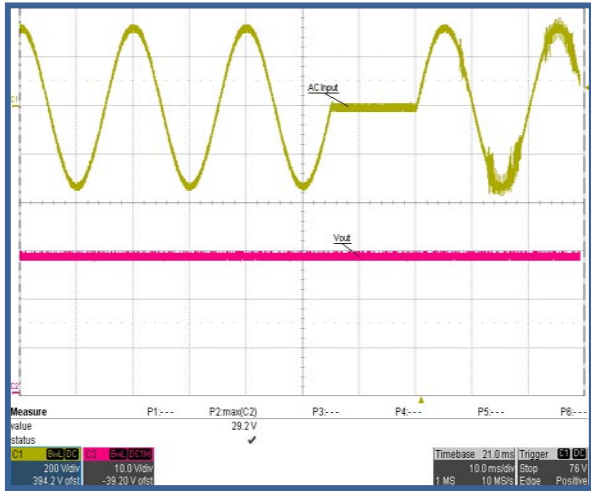

Inrush current at 115Vac - PST21D-28150

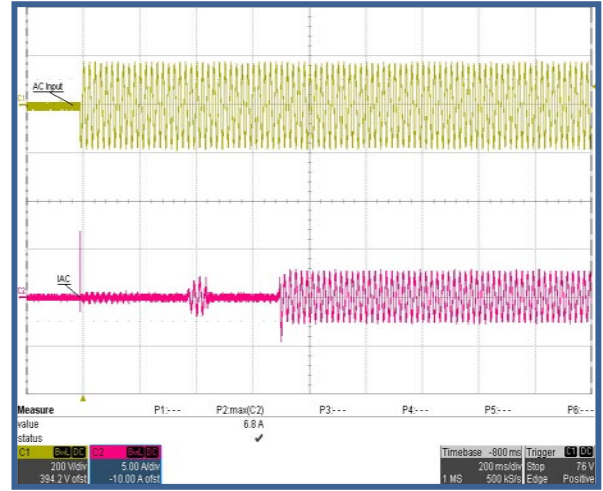

Input power brake at 230Vac 100% Load - PST21D-28150

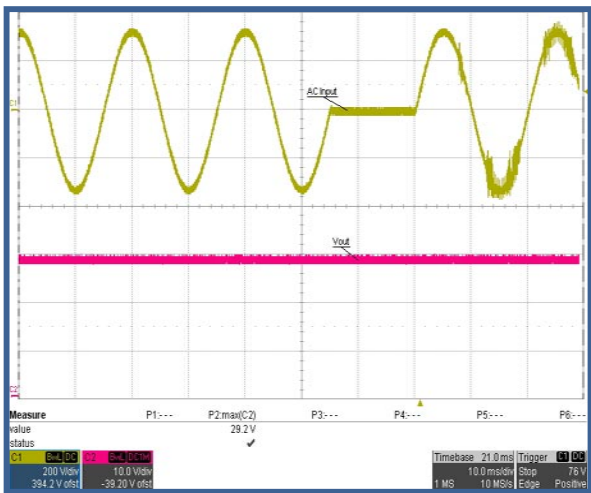

Inrush current at 230Vac - PST21D-28150

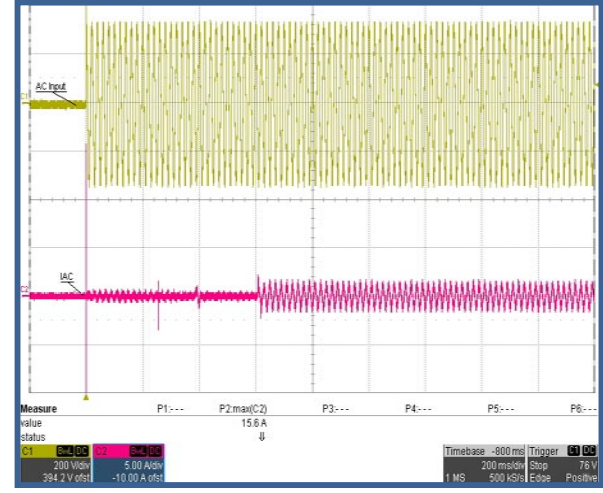

Output

Electrical Output Data

General conditions : 25°C ambient. For each output voltage, max power configuration.

PST21D is based on Micro Module 75W or 150W		2			3V3			5V			8V			12V			15V			24V			28V			48V			Unit
Output	Conditions	min	typ	max	min	typ	max	min	typ	max	min	typ	max	min	typ	max	min	typ	max	min	typ	max	min	typ	max	min	typ	max	
Output voltage			2		3V3			5			8			12			15			24			28			48		V	
Trim range	Factory set	1,8		2,2	3		3,6	4,5		5,5	7,2		8,8	10,8		13,2	13,5		16,5	21,5		26,2	25,2		30,8	43,2	51,8	V	
Overvoltage protection				2,9			4,5			6,5			10,1			14,9			18,5			29,1			34		58	V	
Output noise	20MHz		80			75			75		150			100			100			100			100			150		mVpp	
Efficiency			73			75			83			82			85			84			84			83			84	%	
Load Regulation	Vin nom.			1			1			1			0,5			0,5			1			0,5			0,5			0,5	%
Micromod 75W (50W for 2V, 3V3, 5V)																													
Output current		0		25	0		15	0		10			0		6,25	0		5	0		3,13	0		2,7	0		1,56	A	
Max. power				50			50			50					75			75			75			75			75	W	
Output current limit			29	34		17,5	20,6		11,5	13,5				7,2	8,5		5,8	6,8		3,6	4,25		3,1	3,7		1,8	2,2	A	
Micromod 150W (75W for 3V3, 100W for 5V and 8V)																													
Output current					0		22,7	0		20	0		12,5	0		12,5	0		10	0		6,25	0		5,3	0		3,1	A
Max. power							75			100			100			150			150			150			150			150	W
Output current limit						25	31		23	26		14,5	17		14,5	17		11	14		7,2	8,2		6,2	7		3,6	4,4	A

See "options and configurations" section for all the power possibilities.

Parallel operation & current share

Parallel operation is possible between different units but there is no active current sharing signal available on the PST21D, please use PST21C if needed. Output external circuit has to be used (risk of damage otherwise).

Redundant Systems Operation

When systems require a very high level of reliability and should work normally in the event of a failure, N+1 redundancy is implemented where N is the number of converter to support power requirement. If one converter fails, the remaining ones still delivers the power to the loads.

Redundant operation requires external oring diodes and output external circuit (risk of damage otherwise). PST21C will be preferred for such applications.

Hold-up time

The psu provides internal hold-up time (see curve).

Output Current Limitation

All outputs are continuously protected against short-circuit by a constant current limitation (no foldback) with automatic recovery. See Page 3 for values.

Thermal Considerations

When a converter is mounted in conduction cooled, the temperature measured on the baseplate should not exceed 100°C.

When heatsink option is used in convection cooling and is operating at its nominal output power at the max. ambient temperature, the temperature measured on the heatsink should not exceed 100°C.

Thermal protection

A temperature protection (OTP) is integrated in each output module, disabling output when baseplate temperature exceeds 105°C (+/-5°C). The converter automatically restarts, when the temperature drops below 70°C. Nevertheless, exceeding the max operating temperature may cause failures of the converter.

Overvoltage protection

An OVP is incorporated on each output configuration. Outputs is cut if an OVP is detected. This protection is latch style (Recovery after AC reset or inhibit).

Auxiliary Functions

Remote On/Off (INHIB)

- Secondary Inhibit:** Output disabled if 5V TTL between INIBS+ and INIBS-, enabled if 0V or open. This signal is isolated by optocoupler.
- **Primary Inhibit:** Output disabled if INH+ shorted to INH-. This signal is referenced to the primary side (not isolated), it has to be handle with care (external isolated contact, noise and transient filtered).

Hold up time at 230VAC, 100% load - PST21D-28150

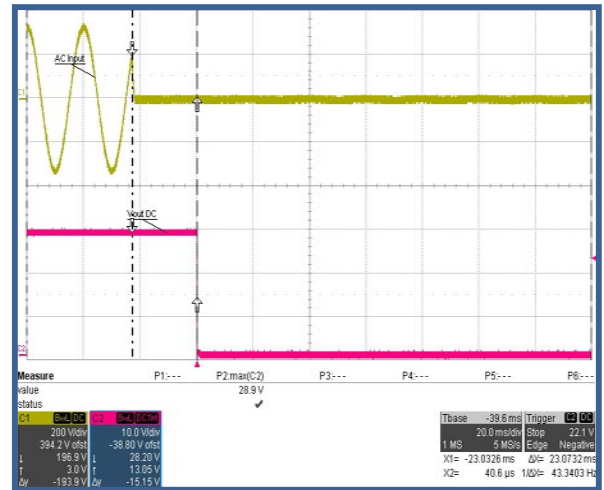

Efficiency curve - PST21D-28150

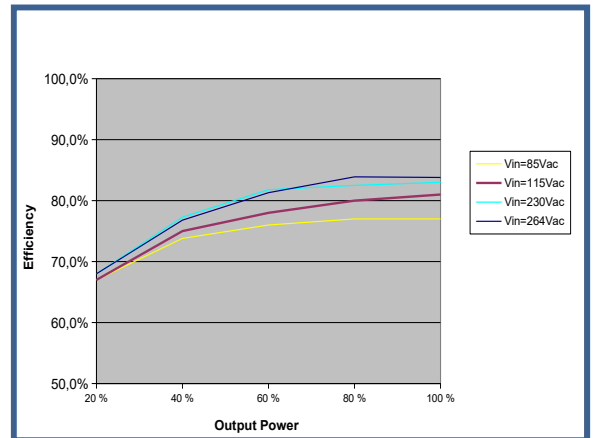

Output Noise - PST21D-28150

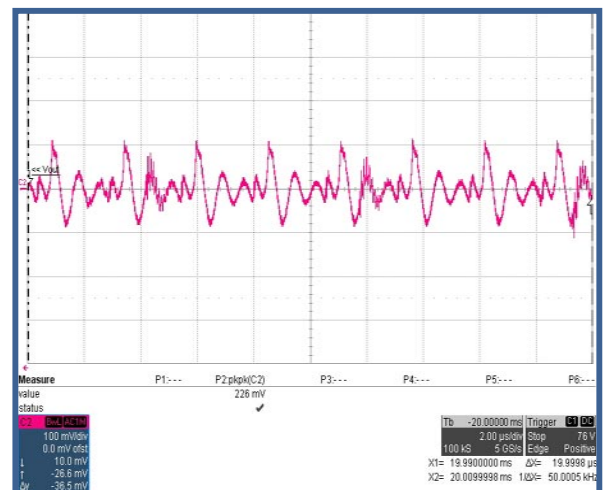

Output Voltage Adjustment (ADJ)

A potentiometer at the output side allows output voltage variation from -10% to +10% of Vnom. The TRIM signal allows output voltage to be adjusted by an external voltage 1,15 to 1,25Vmax voltage referred to -OUT. Extended range of adjustment down to -50% can be considered as semi standard product, consult factory.

Remote Senses (+S -S)

There is no remote sense functionality integrated in the PST21D for compensation of voltage drop across the connector contacts and the load lines. Remote Sense can be done by an external circuit acting on the TRIM signal.

PowerGood & LED (Pgood+ Pgood-)

Isolated Open collector Pgood+, Pgood-, closed if Vout is in its normal range (30Vdc/10mA max.). A green led placed at the output on the topside indicates output voltage is ON.

Powergood Signal - PST21D-28150

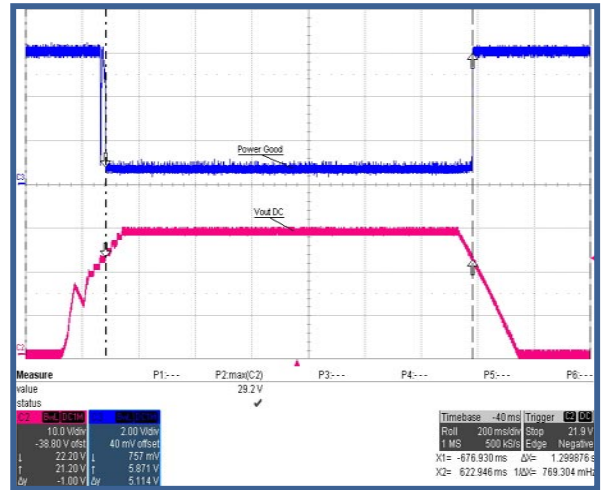

Temperature Derating - PST21D-28150 conduction cooled

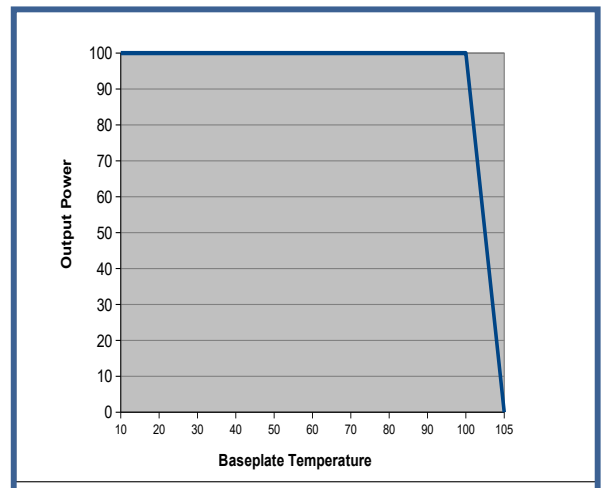

Temperature Derating - PST21D-28150 convection and air forced cooled

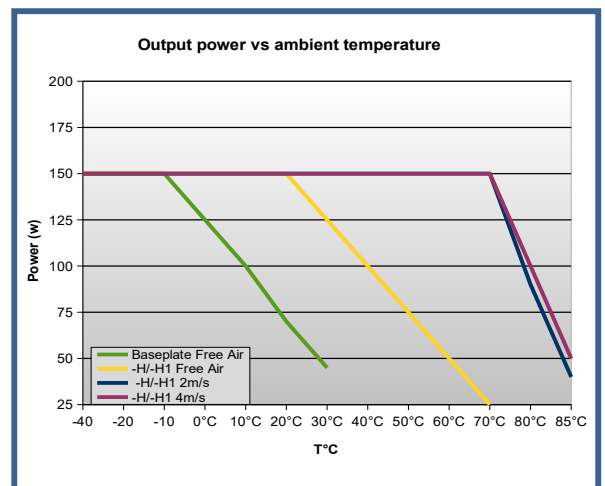

Electromagnetic

Electromagnetic Immunity

		Standard		Level	Value	Waveform	Source imped.	Test procedure	Mode	Criteria
Surges	Built to meet	EN 61000-4-5	DM	3	1KV	1,2 / 50 μ s	12 ohms		OP	B
			CM		2KV	1,2 / 50 μ s	12 ohms		OP	A
Electrostatic discharge (to case)	Built to meet	EN 6100-4-2		4	8000V	1 / 50 μ s	330 Ohms	10 pos., 10neg.	OP	B
Electrical fast transients/burst	Built to meet	EN 61000-4-4		4	4000V	5 / 50 μ s	50 ohms		OP	B

Note : Built to meet EN 61000-4 -3, -6, -11, Harmonics EN 61000-3-2, Flickers EN 61000-3-3

Electromagnetic Emissions

According to the configuration and revision, EMI results could change. External filter may be required to meet EN55022A or B and MIL-STD461E CE102.

PST21D-28150 IND04 EN55022B
230Vac/50Hz 100% load

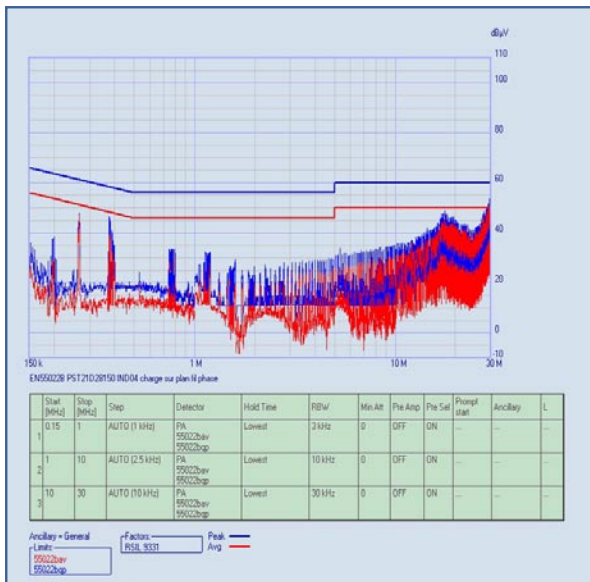

PST21D-28150-MTV IND04 MIL-STD461 CE102
230Vac/50Hz 100% load

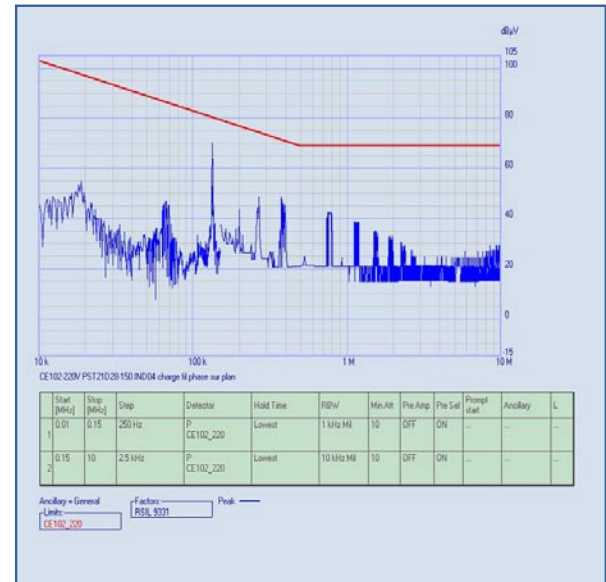

PST21D-28150 IND04 EN55022B
115Vac/50Hz 100% load

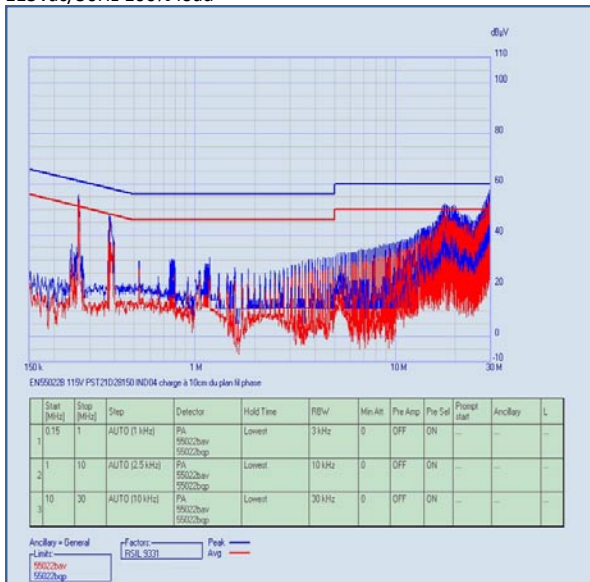

PST21D-28150-MTV IND04 MIL-STD461 CE102
115Vac/400Hz 100% load

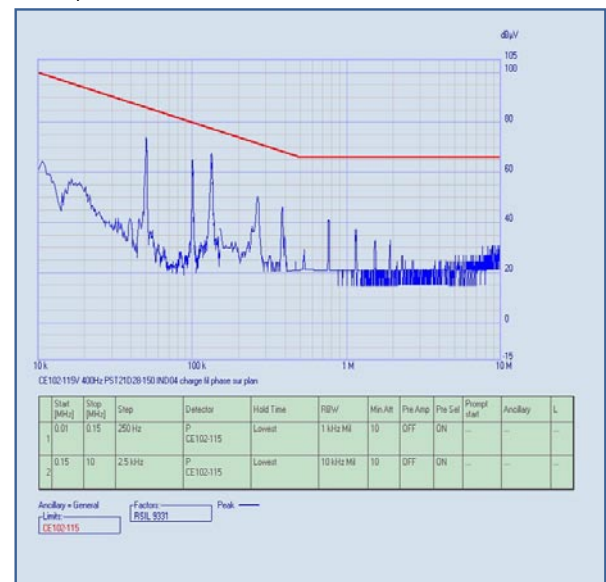

Immunity to Environmental Conditions

Test method	Standard	Test conditions	Status
Damp Heat	MIL STD 810F Proc. 507-2	Humidity 93 %, 40°C, 56 days	Option (-V), built to meet
Shock	MIL STD 810F Proc.516.3	20g / 18ms half size 5g / 30ms	Option (-M), built to meet
Vibrations	MIL STD 810F Proc. 514-5	4-80Hz (2,8m/s ²) ² /Hz, non operating 160-500Hz (0,175m/s ²) ² /Hz, non operating	Option (-M), built to meet

Mechanical data

Size : 165 x 61 x 35 mm. Aluminum Natural . Weight : 415g without heatsink
Note: the datasheet Rev01 and above are based on the product PST21D IND04 revisions.

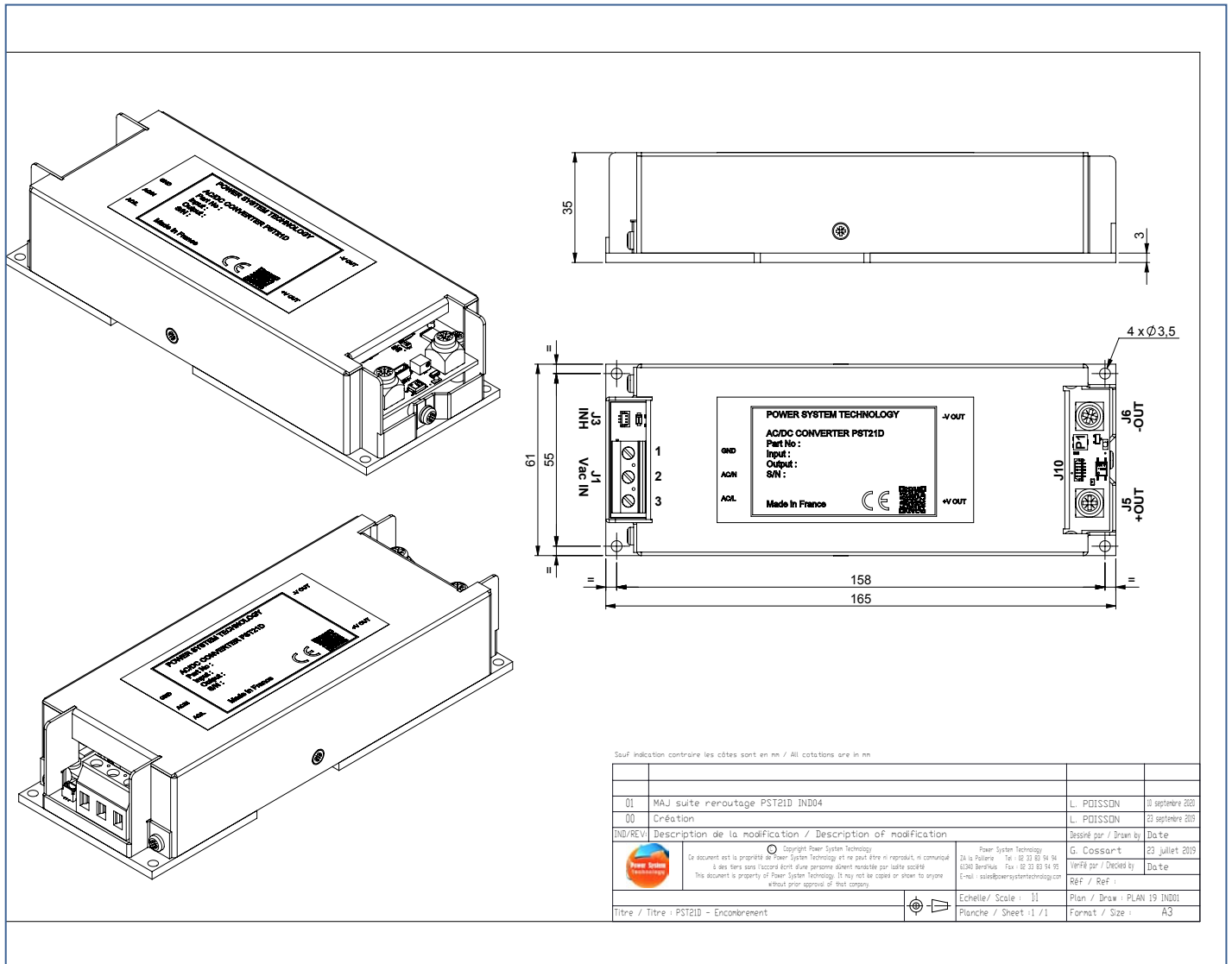

The technical drawing shows the following dimensions and features:

- Overall dimensions: 165 mm (length) x 61 mm (width) x 35 mm (height).
- Terminal block J10 on the left with pins 1, 2, 3 labeled. Labels: IN, VAC, NI, J10.
- Terminal block J6 on the right with pins 1, 2, 3 labeled. Labels: J6, -OUT, +OUT.
- Mounting holes: 4 x Ø 3.5.
- Label on the top surface: POWER SYSTEM TECHNOLOGY ACDC CONVERTER PST21D, Part No., Input, Output, SIN, Made in France.

Sauf indication contraire les côtes sont en mm / All cotations are in mm

01	MAJ suite reroutage PST21D IND04	L. POISSON	23 septembre 2019
00	Création	L. POISSON	23 septembre 2019
IND/REV	Description de la modification / Description of modification	Dessiné par / Drawn by	Date
		G. Cossart	23 juillet 2019
		Verifié par / Decided by	Date
		Réf / Ref :	
Titre / Titre : PST21D - Encombrement		Echelle / Scale : 1/1	Plan / Draw : PLAN 19 IND01
		Planche / Sheet : 1 / 1	Format / Size : A3

PST21D - H option

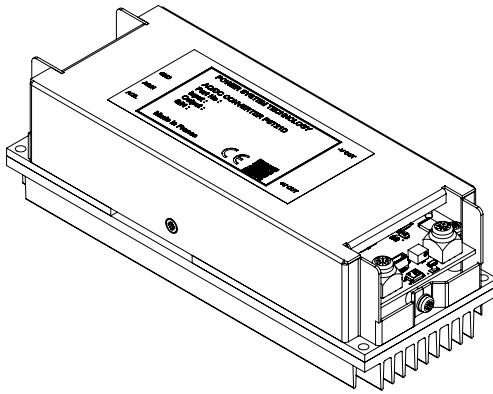
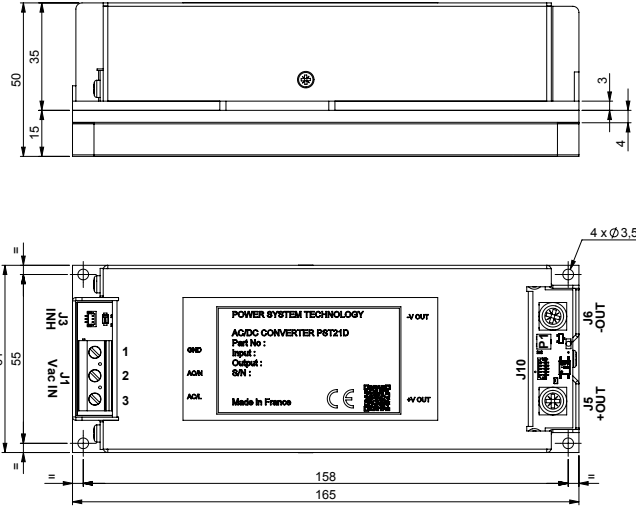
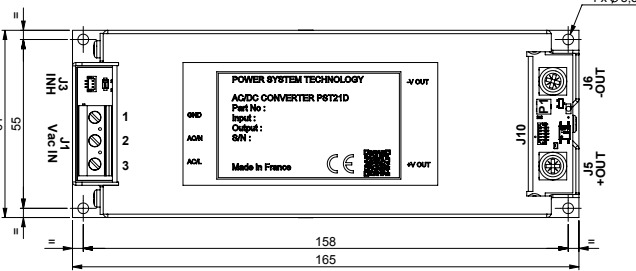
POWER SYSTEM TECHNOLOGY
ACDC CONVERTER PST21D
Part No :
Input :
Output :
SN :
Made in France

4 x Ø3.5

J10

J5 +OUT

J6 -OUT

158

165

61

55

50

35

15

3

4

Sauf indication contraire les cotes sont en mm / All cotations are in mm

01	MAJ suite reroutage PST21D IND04	L. POISSON	03 septembre 2013
00	Création	L. POISSON	03 septembre 2013
IND/REV	Description de la modification / Description of modification	dessiné par / Drawn by	Date
	 Copyright Power System Technology. Ce document est la propriété de Power System Technology et ne peut être ni reproduit, ni communiqué à des tiers sans l'autorisation écrite préalable de Power System Technology. This document is property of Power System Technology. It may not be copied or shown to anyone without prior approval of Power System Technology.	Power System Technology 33 - La Rochelle - Tél: 02 33 53 34 34 6330 Bertheux - Fax: 02 33 53 34 35 E-mail: sales@powersystemtechnology.com	G. Cossart 23 juillet 2013 Vérifié par / Checked by Date REF / REF :
Titre / Titre : PST21D-H - Encombrement		Echelle / Scale : 1:1	Plan / Draw : PLAN 11 IND01
		Planche / Sheet : 1 / 1	Format / Size : A3

PST21D - H1 option

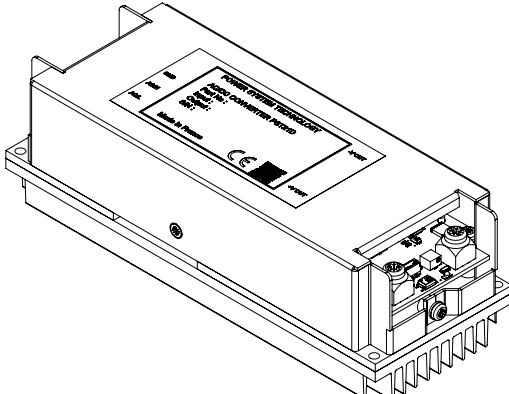
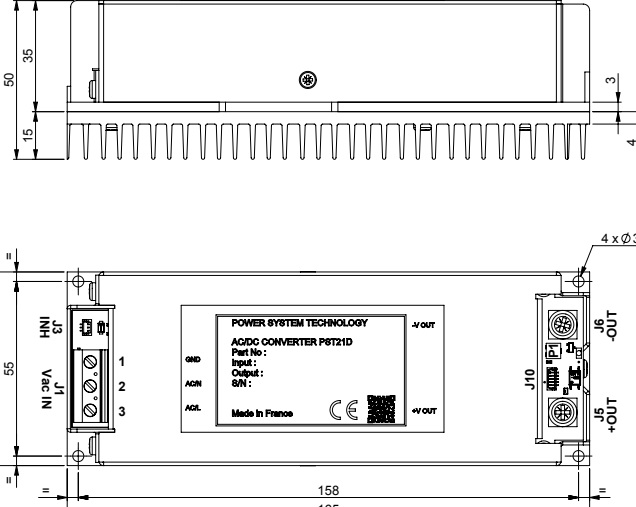
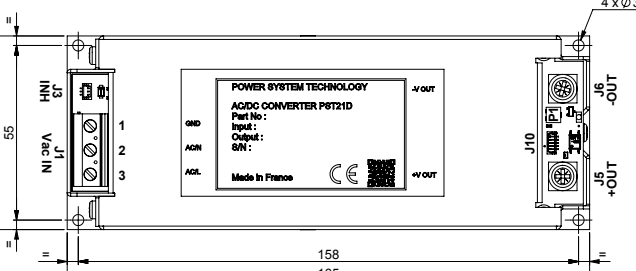
POWER SYSTEM TECHNOLOGY
ACDC CONVERTER PST21D
Part No :
Input :
Output :
SN :
Made in France

4 x Ø3.5

J10

J5 +OUT

J6 -OUT

158

165

61

55

50

35

15

3

4

Sauf indication contraire les cotes sont en mm / All cotations are in mm

01	MAJ suite reroutage PST21D IND04	L. POISSON	03 septembre 2013
00	Création	L. POISSON	03 septembre 2013
IND/REV	Description de la modification / Description of modification	dessiné par / Drawn by	Date
	 Copyright Power System Technology. Ce document est la propriété de Power System Technology et ne peut être ni reproduit, ni communiqué à des tiers sans l'autorisation écrite préalable de Power System Technology. This document is property of Power System Technology. It may not be copied or shown to anyone without prior approval of Power System Technology.	Power System Technology 33 - La Rochelle - Tél: 02 33 53 34 34 6330 Bertheux - Fax: 02 33 53 34 35 E-mail: sales@powersystemtechnology.com	G. Cossart 23 juillet 2013 Vérifié par / Checked by Date REF / REF :
Titre / Titre : PST21D-H1 - Encombrement		Echelle / Scale : 1:1	Plan / Draw : PLAN 10 IND01
		Planche / Sheet : 1 / 1	Format / Size : A3

PST21D - IP option

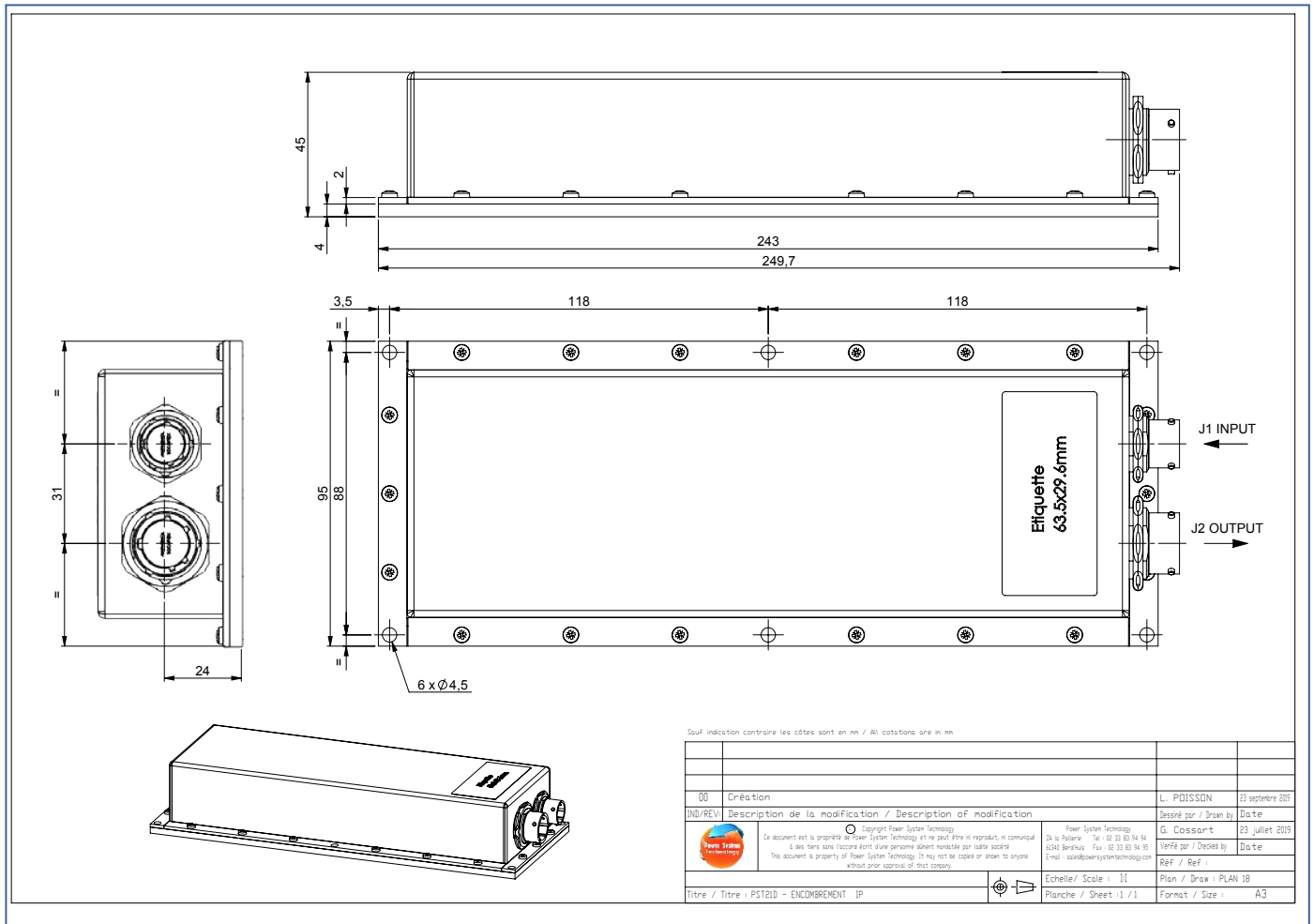

▼ Connector Pin Allocation

PST21D		
PIN	Description	
Input Screw type connector GMKDS 3/3-7.62		
J1-1		Earth
J1-2	AC/N	Neutral
J1-3	AC/L	Line
Output		
J5	OUT+	Wurth Press Fit M4 Ref : 7461095
J6	OUT-	Wurth Press Fit M4 Ref : 7461095
Input Inhibition signal JST 3 points BM03B-SRSS-TB(LFSN)		
J3-1	INH+	Input referenced Inhibit +
J3-2		NC
J3-3	INH-	Input referenced Inhibit -
Output Signals JST 5 points BM05B-SRSS-TB(LFSN)		
J10-1	INIBS-	Secondary referenced Inhibit
J10-2	PGOOD-	Output Ok signal Emitter
J10-3	PGOOD+	Output Ok signal Collector
J10-4	TRIM	Output voltage Adjustment
J10-5	INIBS+	Secondary referenced Inhibit

▼ Pin Allocation -IP option

PST21D – IP version – Connector Pin Allocation		
PIN	Description	
Input Connector AMPHENOL SOCAPEX – 45107A106P50		
A	INH+	Input referenced Inhibit
B	AC/L Line	
C	NC	
D	Earth	
E	-HT	Input referenced Inhibit RTN
F	AC/N Neutral	
Output Connector AMPHENOL SOCAPEX – 45107A12-14S50		
B		
C		
F	OUT+	
H		
L		
M	OUT-	
P		
R		
A	INIBS+	Secondary referenced Inhibit
D	INIBS-	Secondary referenced Inhibit
E	TRIM	Output Voltage Adjustment
N	PGOOD-	Output OK Signal Emitter
J	PGOOD+	Output OK Signal Collector
K	NC	

▼ Safety & Installation

These converters are components, intended exclusively for integration into other equipment by an industrial assembly process or by a professionally competent person. Installation must strictly follow the safety regulations in respect of the enclosure, mounting, creepage and clearance distances, markings of the end-use application.

Connection to the system shall be made via the male connector Würth.

The AC/L is internally fused. This fuse is designed to protect the converter against overcurrent caused by a failure, but may not be able to satisfy all requirements. External fuses in the wiring circuit to one or both input pins may be necessary to ensure compliance with local requirements.

Do not open the PSU, or the warranty will be invalidated. Make sure that there is sufficient thermal baseplate dissipation (absolute max. temperature : 100°C). This should be verified by measuring the case of temperature at the specified measuring point, when the converter is operated in the end-use application.

Standards and Approvals

The converters are built to meet the safety standards IEC 62368-1, EN 62368-1.

'Built to meet' mentioned in the different paragraphs of the datasheet means that Power System Technology has designed the product to meet the standard but not certified it in a laboratory.

'Qualified' means that the test has been made in a certified laboratory.

Cleaning Agents and Process

The converters are not hermetically sealed. In order to avoid possible damage, any penetration of liquids shall be avoided.

Isolation

The electric strength test is performed in the factory in accordance with IEC/EN 62368.

Electric Strength

Characteristic		Input to Earth	Input to Output	Output to Earth	Output to Output	Unit
Electric strength	Design strength	1500	3000	500		Vrms
	Factory test for production units (>10s)	2120	2120	500		Vdc
Insulation resistance				> 100	>100	Mohms

Temperatures

Conditions		Standard			T option			Unit
		Min.	Typ.	Max.	Min.	Typ.	Max.	
Ambiant	Operating (see derating)	-20		+71	-40		+71	°C
Heatsink		-20		+100	-40		+100	
Storage	Not operating	-40		+125	-40		+125	

In operation, there is no power derating as long as the baseplate temperature is in the indicated range.

Reliability

MIL-HDBK-217F, notice 2	Model	Baseplate Temp.	GB	GF
MTBF (Hours)	PST21D 1 output 150W	40°C	302750	172566
		70°C	145320	84558
		100°C	88644	52426

MTBF calculation for a specific part number has to be ordered.

Options and configurations

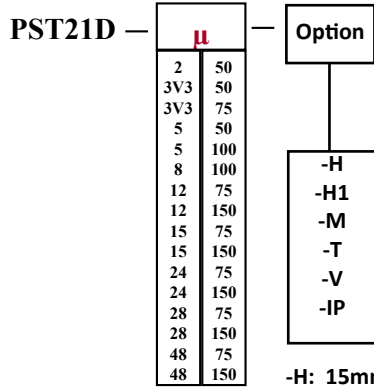

- H: 15mm Heatsink longitudinal fins
- H1: 15mm Heatsink transversal fins
- M : Ruggedized
- T : -40°C
- V : Conformal coating
- IP: IP65 Enclosure

ANSPRECHPARTNER



Für Fragen stehe ich Ihnen gerne persönlich zur Verfügung,

+43 (676) 466 466 0

od. per E-Mail

robert.glaser@glaser-eng.com .

Anfragen nehmen wir gerne unter der E-Mail-Adresse

info@glaser-eng.com

entgegen.



Y o u r t h o u g h t i s o u r p a s s i o n !

info@glaser-eng.com

www.glaser-eng.com