

PST27

DC-DC | 300W | 2 outputs

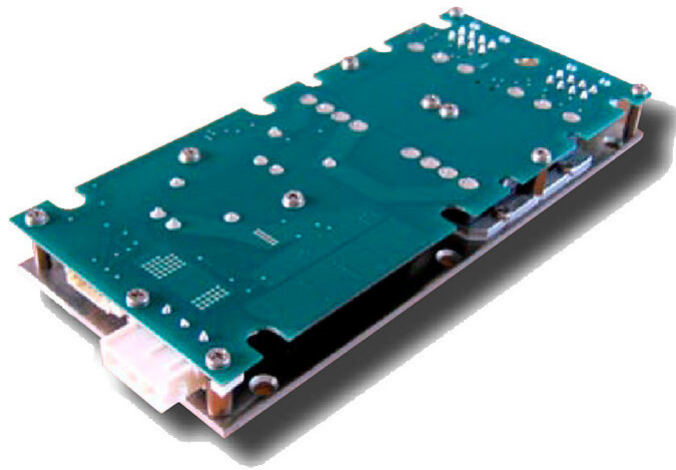

PRODUCTCARD

Electronic | Mechatronic | Optics | Special App

IHR VORTEIL - UNSERE STÄRKEN

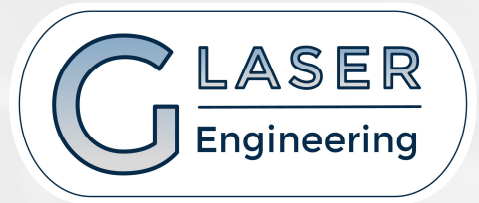

- Europäische Entwicklung
- Europäische Herstellung unter Berücksichtigung von ISO 9001, EN 9100, ISO 14001, ISO 45001
- Kurze Lieferkette
- Kurze Produktionszeiten, da die meisten Bauteile bevorratet werden können.
- Individualisierung nach Kundenwunsch bzw. Anpassung von Formfaktor, Konnektivität und Leistung möglich.
- Standard und ruggedized Varianten
- Modulare Bauweise (mehrere Stromquellen sind System technisch zusammengefasst), Vereinfachung von Konstruktion, Assembling und Service.
- Europäische Normen z.B. EN61000-3-2, EN55022B oder MIL-STD461E CE102, MIL-STD810E
- Alles aus einer Hand:
Design-In, Vertrieb und Abnahme durch das Ingenieurbüro **GLASER Engineering**

DC-DC Conduction cooled PST27 300W

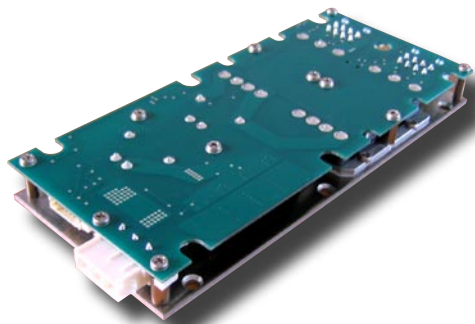

Features

- 12,24,48Vdc Input voltage
- 2 outputs, 300W max.
- 80*190*21mm
- Surge and transient protected
- 10°C to 90°C baseplate, -40°C option T
- Severe environment

Safety IEC/EN 60950-1, RoHS lead-free-solder compliant



The PST27, Very low profile DC-DC converter incorporates input filtering, very robust mechanical, conformal coating, required in most of the severe environments. The converter provides high reliability thanks to the integration of Vicor Corp. modules, high efficiency, input-to-output isolation, soft start, input over/undervoltage lockout. The converter is protected against surges and transients, EMI filtered built to meet MIL-STD 461, MIL-STD 810, MIL-STD 704 and MIL-STD 1275. The output is continuously short-circuit proof.

Bloc diagram

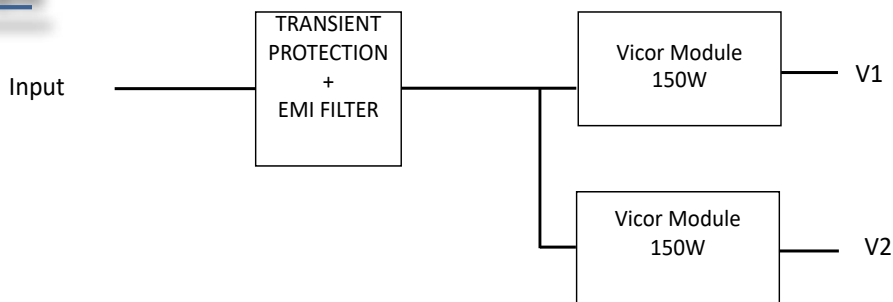

Electrical Input Data

Input		12			24			48			Unit
Characteristics	Conditions	min	typ	max	min	typ	max	min	typ	max	
Operating input voltage		9	12	36	18	24	36	36	48	75	Vdc
Input current	V1 = 100W & V2 = 100W			15		15			7.5		A
No-load input power	V1 = 0W & V2 = 0W		9			9			9		W
Peak inrush current				6			6			12	A
Power interruption	Vin Nom., V1=100W, V2=100W		165			165			165		µs
Start-up time			40			40			40		ms

Configuration

PST27	V1		V2		Option
	Vin	Vout	Pout	Vout	
12	N	N	N	N	H
24	3V3	50	3V3	50	H1
48	5	75	5	75	M
	12	100	12	100	T
	15	150	15	150	V
	24		24		
	28		28		
	48		48		

Electrical Output Data

Output		V1			V2			Unit
Characteristics	Conditions	min	typ	max	min	typ	max	
Output voltage	At 25°C	-0,95Vnom	Vnom	+0,95Vnom	-0,95Vnom	Vnom	+0,95Vnom	Vdc
Output current limitation	At 25°C	105% Inom	Inom	115 % Inom	105% Inom	Inom	115 % Inom	A
Output noise	At 25°C		240			240		mVpp
Overvoltage protection	At 25°C. Recover by off/on line			115% Vnom			115% Vnom	Vdc
Efficiency	Vin = 24Vdc		85			85		%
Thermal protection			95			95		°C

Option

- H : Heatsink longitudinal fins
- H1 : Heatsink transversal fins
- M : Ruggedized
- T : -40°C
- V : Conformal coating



▼ Signals

- PowerFail: Open collector referenced to GND CUST, closed if input voltage is in its normal range, open if below the operating range.
- Powergood+: Open collector referenced to GND CUST.
Closed if V1 or V2 is in its normal range
- Inhibit: Disable if 5V TTL between module disable + and -
Enable if 0V or open between module disable + and -
- Inhibit_Inv: Disable if 0V TTL or Closed contact between module disable_Inv + and -
Enable if 5V TTL or left open between module disable_Inv + and -

▼ Isolation

- Dielectric withstand Input/chassis: 2120Vdc
- Dielectric withstand Input/Output : 2120Vdc
- Insulation resistance Output1/Output2 : 100Mohms/500Vdc
- Insulation resistance Output /Chassis: 100Mohms/500Vdc

▼ Approvals & Environment

Built to meet standards - No laboratory certification

EMI : MIL STD 461E CE102

Temperature :

Stockage : -40 +100°C

Operating : -10 +90°C baseplate, conduction cooled, -40°C option T

Option M :

Input voltage spikes : MIL-STD 704- 100V/50ms (12&24Vin only)

MIL-STD1275D - 100V/50ms (12V&24Vin only)

Altitude: 3000M

Shock & Acceleration : MIL STD 810

Operational shock : MIL STD 810

Crash safety shock (Impulse) : MIL STD 810

▼ Mechanical Data

80 x 190 x 21mm

Weight : 0,286Kg

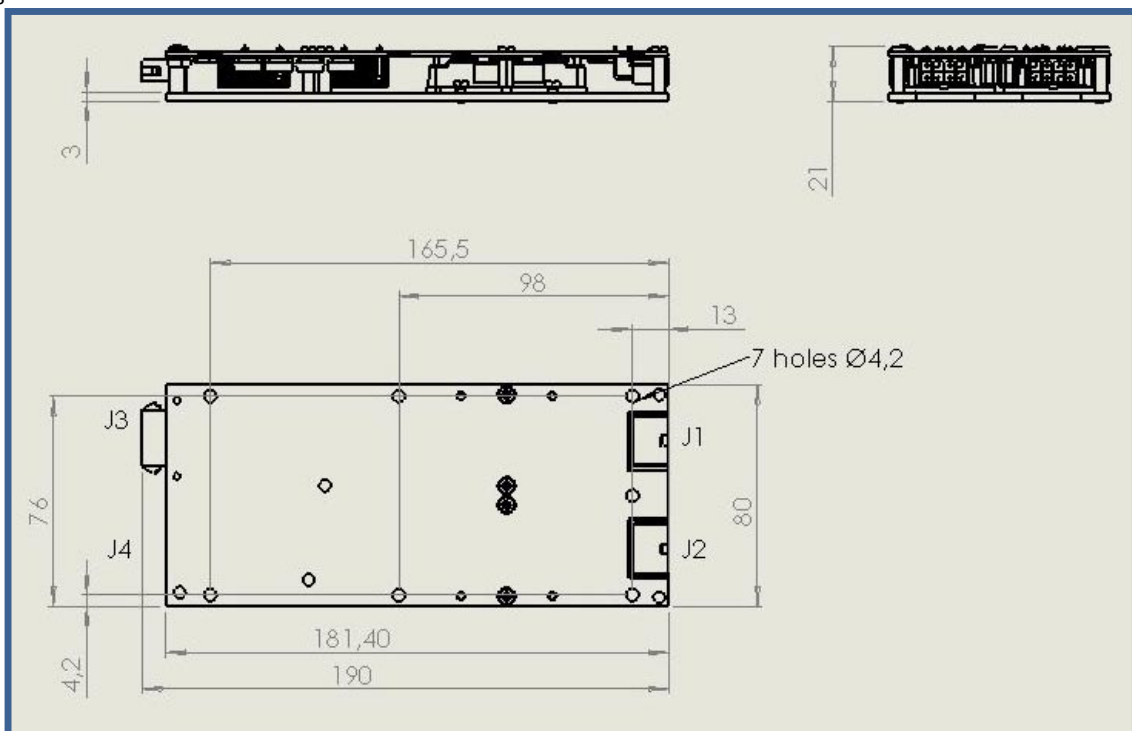

▼ Connector Pin Allocation

J1 : MOLEX 39301080

PIN	signal name	description
1	+VOUT1	OUTPUT+
2	+VOUT1	OUTPUT+
3	-VOUT1	OUTPUT-
4	-VOUT1	OUTPUT-
5	+VOUT1	OUTPUT+
6-7	NC	
8	-VOUT1	OUTPUT-

J2 : MOLEX 39301080

PIN	signal name	description
1	+VOUT2	OUTPUT+
2	+VOUT2	OUTPUT+
3	-VOUT2	OUTPUT-
4	-VOUT2	OUTPUT-
5	+VOUT2	OUTPUT+
6-7	NC	
8	-VOUT2	OUTPUT-

J3 : TE connectivity 1-350943-0

PIN	signal name	description
1	EARTH	EARTH
2	-Vin	INPUT -
3	+Vin	INPUT +

J4 : JST S7B-PH-SM4-TB

PIN	signal name	description
1	Power fail	Signal fail output
2	Disable -	Positive logic inhibit
3	Disable +	Positive logic inhibit
4	GND CUST	Return signal output
5	Power good+	Signal power good output
6	Disable_Inv -	Inverted logic inhibit
7	Disable_Inv +	Inverted logic inhibit
8	NC	

ANSPRECHPARTNER



Für Fragen stehe ich Ihnen gerne persönlich zur Verfügung,

+43 (676) 466 466 0

od. per E-Mail

robert.glaser@glaser-eng.com .

Anfragen nehmen wir gerne unter der E-Mail-Adresse

info@glaser-eng.com

entgegen.



Y o u r t h o u g h t i s o u r p a s s i o n !

info@glaser-eng.com

www.glaser-eng.com