

# PSTCPCI-AC

AC-DC | 300W | 4 outputs



PRODUCTCARD

Electronic | Mechatronic | Optics | Special App

## IHR VORTEIL - UNSERE STÄRKEN

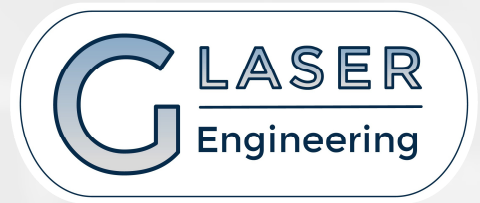

- Europäische Entwicklung
- Europäische Herstellung unter Berücksichtigung von ISO 9001, EN 9100, ISO 14001, ISO 45001
- Kurze Lieferkette
- Kurze Produktionszeiten, da die meisten Bauteile bevorratet werden können.
- Individualisierung nach Kundenwunsch bzw. Anpassung von Formfaktor, Konnektivität und Leistung möglich.
- Standard und ruggedized Varianten
- Modulare Bauweise (mehrere Stromquellen sind System technisch zusammengefasst), Vereinfachung von Konstruktion, Assembling und Service.
- Europäische Normen z.B. EN61000-3-2, EN55022B oder MIL-STD461E CE102, MIL-STD810E
- Alles aus einer Hand:  
Design-In, Vertrieb und Abnahme durch das Ingenieurbüro **GLASER Engineering**

## CPCI AC

Standard product AC-DC CompactPCI® 300W



### Features

- ▶ 85-265Vac or 100-350Vdc input voltage ranges
- ▶ 4 outputs
- ▶ Output power 300W
- ▶ Power Factor Correction EN61000-3-2
- ▶ Active very low inrush limitation
- ▶ Surge and transient protection
- ▶ Current sharing & N+1 redundancy
- ▶ 3U x 8TE x 160mm

Safety IEC/EN 60950-1, RoHS lead-free-solder compliant



### Description

The CPCI AC, AC-DC CompactPCI® compliant with PICMG 2.11 standard, incorporates input and output protections and filtering, signalling features, required in severe environments for industrial, defense, avionic applications. The PSU provides significant advantages, high reliability thanks to the integration of Vicor Corp. modules, high efficiency, low ripple and noise levels, input-to-output isolation, soft start, MOFSET based active very low inrush limitation circuit, overtemperature protection, input over/undervoltage lockout. The input is protected against surges and transients and EMI filtered. The outputs are continuously short-circuit proof. LEDs in front panel indicates the status of the psu.

### Bloc diagramm

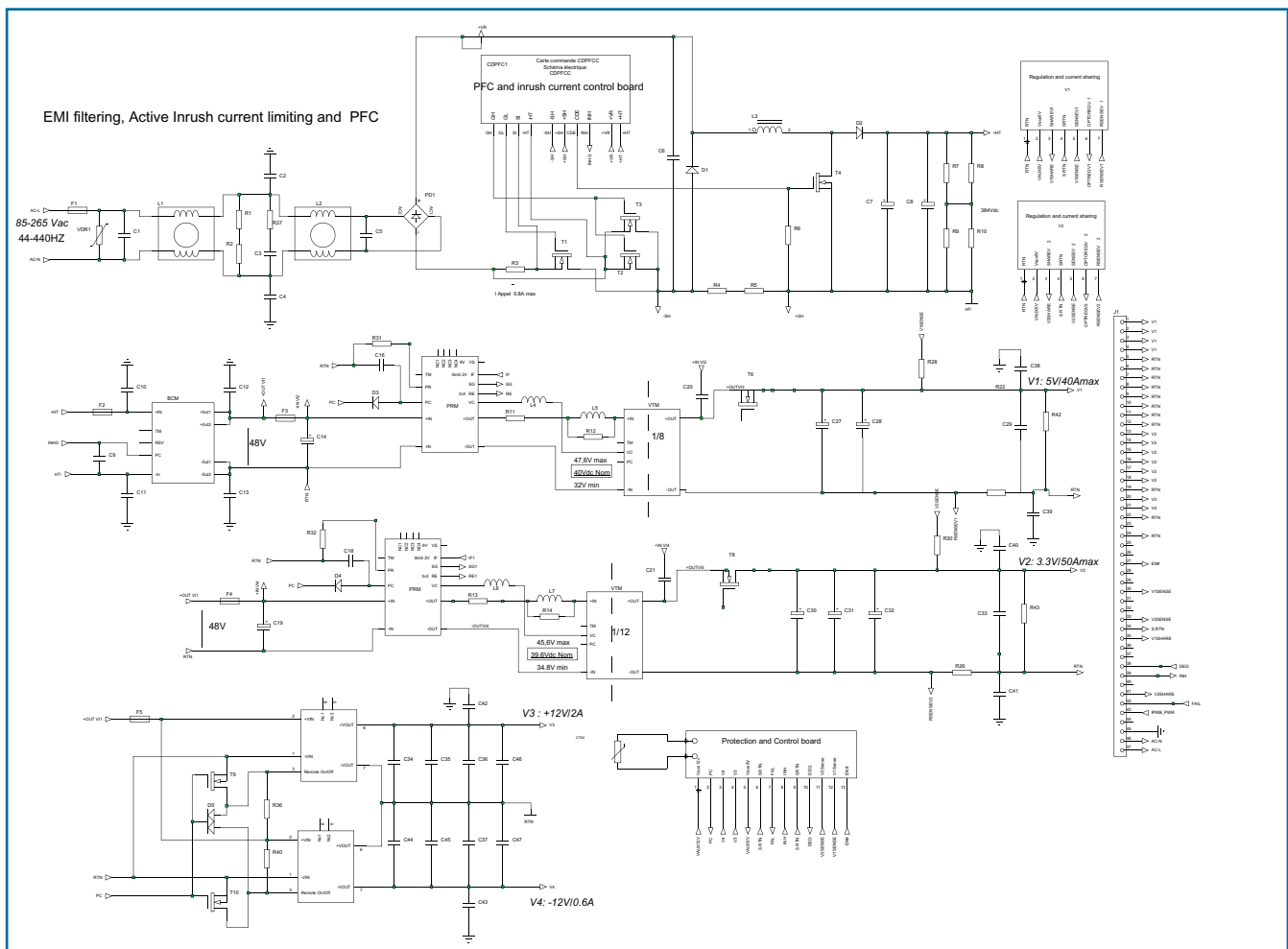

## Options Description

### MIL-STD ruggedized (M)

Meet MIL-STD 461E CE102, MIL-STD 1399-300A, MIL-STD810E shock & vibrations. Laboratory certification.

### -40°C operation (T)

The thermal grade of the Vicor the DC/DC converters used and other components are changed to comply with low ambient temperature.

### Conformal coating (V)

During manufacturing process , when V option is specified, components and pcb are covered with an acrylic coating to address high level of ambient humidity application.

### 61000-4-5 (Y)

Include a common mode surge protection 61000-4-5 Level 3 2KV based on gas discharger and VDR to meet criteria A. **BE CAREFUL not to apply dielectric test** if this option is choosen. If no Y option, criteria B is met.

## Input

### Electrical Input Data

Input					Unit
Characteristics	Conditions	min	typ	max	
Operating input voltage		85		265	Vac
Operating input voltage		100		350	Vdc
Frequency		44	50	440	Hz
Power Factor	230Vac, 50Hz, Pnom.		0,96	0,98	
Input current	At Vin min			4,1	A
No-load input power	At Vin typ			15	W
Peak inrush current	Vin max			4	A
Start-up time				1	s

### Input Fuse

A fuse mounted inside the converter protects against damages in case of a failure. The fuse is not user-accessible. In DC mode, reverse polarity at the input is protected and will not cause the fuse to blow .

Model	Fuse type	Rating	Reference
CPCI AC	Schurter	5A	340300173

### Input Transient Protection

A VDR (Voltage Dependent Resistor) and a common mode input filter form an effective protection against input transients in severe environments.

## Output

### Electrical Output Data

General conditions : 25°C ambient.

		Max output power 325W overall												
Output		V1			V2			V3			V4		Unit	
Characteristics	Conditions	min	typ	max	min	typ	max	min	typ	max	min	typ	max	
Output voltage			5		3V3			12			-12			V
Set point accuracy		4,95		5,05	3,26		3,33	11,5		12,5	-11,5		-12,5	V
Trim range		4,5		5,5	3		3,6							V
Overvoltage protection			5,66			3,8			13,6			-13,6		V
Output current		0		40	0		50	0		1	0		1	A
Output current limit			48			59			1,5			1,5		A
Output noise	20MHz		75			50			90			90		mVpp
Line Regulation	Vout nom.		0,05			0,05			0,05			0,05		%
Load Regulation	Vin nom.			0,1			0,1			1				%

### Efficiency curve

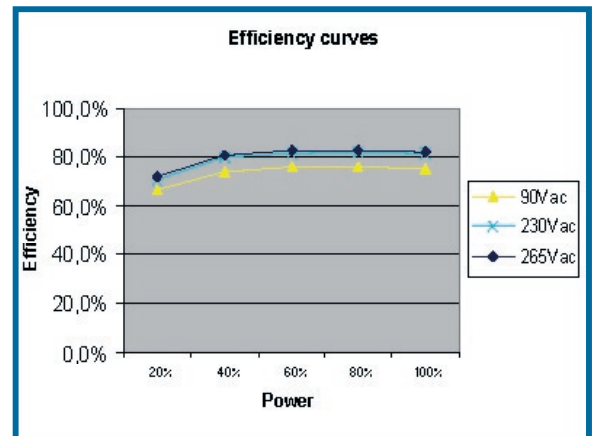

### Power factor curve

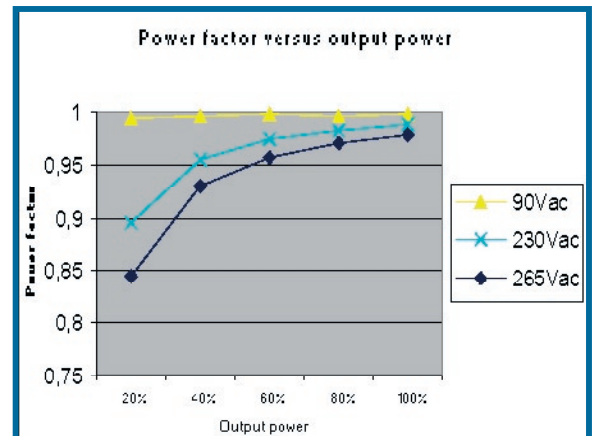

### Establishment time curve

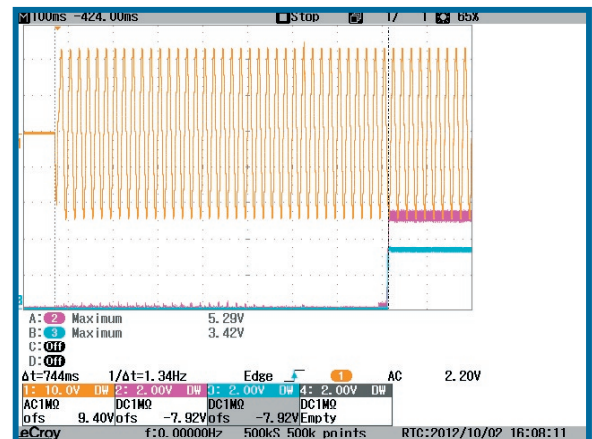

### Parallel operation & current share

Parallel operating is possible for V1, V2 with active current sharing. The signals SHARE are single wire. All V1 SHARE of the different psu in parallel will have to be connected together. (Same for V2 SHARE).

### Redundant Systems Operation

When systems require a very high level of reliability and should work normally in the event of a failure, N+1 redundancy is implemented where N is the number of converter to support power requirement. If one converter fail, the remaining ones still delivers the power to the loads.

Redundant operation is directly provided without need of external diodes and is made internally by an active MOFSET circuit.(reduction of losses).

### Hold-up time

The converters provide internal hold-up time (see curve).

### Hot Swap

The unit incorporates active limitation by MOFSET with very low value of inrush current allowing hot swap operation. See curve.

### Output Current Limitation

All outputs are continuously protected against short-circuit by a constant current limitation (no foldback) with automatic recovery. See Page 2 for the value.

### Thermal Considerations

When a converter is mounted in free air, convection cooling and is operating at its nominal output power at the max. ambient temperature, the temperature measured on the heatsink should not exceed 95°C. The derating curves show the max power available from the converter versus ambient temperature.

### Thermal protection & degrade signal

A temperature protection (OTP) is integrated in the unit, disabling output when heatsink temperature exceeds 90°C (+/-5°C). The converter automatically restarts, when the temperature drops below 55°C (+/-5°C). Nevertheless, exceeding the max operating temperature may cause failures of the converter.

A degraded signal (DEG), open collector, is provided when temperature exceed 80°C +/-5°C(active low) and is reset below 70°C +/-5°C. This can be monitored external system to reduce power and avoid thermal protection. DEG is opened when temperature is within operating range.

### Overvoltage protection

An OVP is incorporated on each output. All outputs are cut if an OVP is detected. This protection is latch style (Recovery after AC reset or inhibit).

Output	OVP value
+5V	5,66V
+3V3	3,80V
+12V	13,6V
-12V	-13,6V

### Hold up time

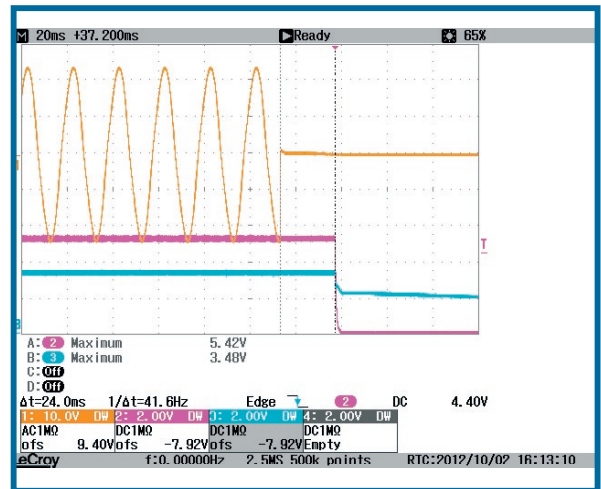

### Inrush current Active Limitation

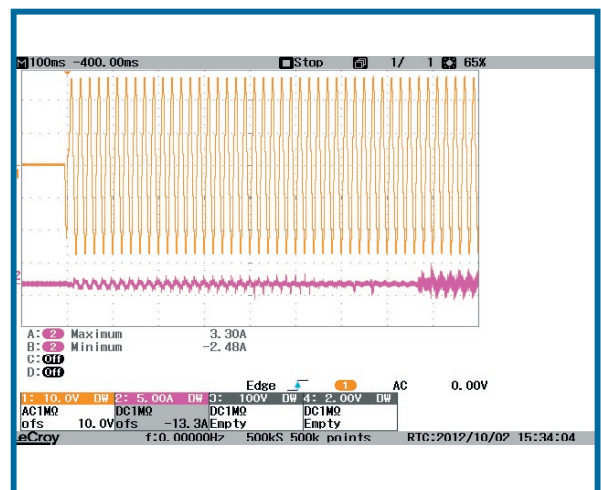

### Output power ambient 2ms + 4ms

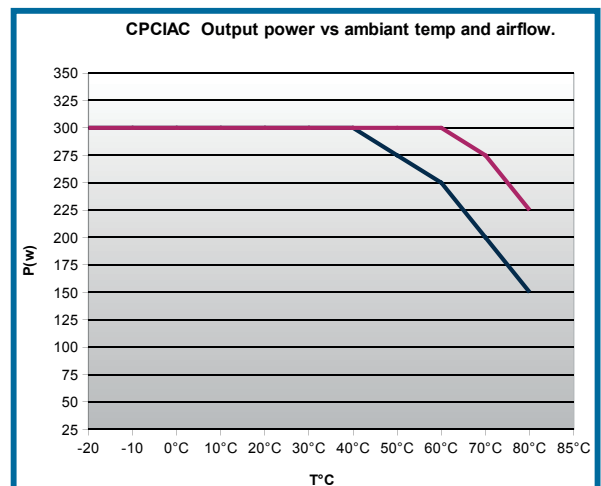

## Auxiliary Functions

### Inhibit (Remote On/Off)

A INH signal activate & de-activate the output voltages  
 - outputs inhibited : INH level LOW

### Output Voltage Adjustment

The converter outputs can be factory adjustable to different values than standard ones. Consult factory.

### Sense Lines

This feature enables compensation of voltage drop across the connector contacts and the load lines. This functionality is implemented on V1 & V2 only.

The voltage between any sense line and its respective power output pin (as measured on the connector) should not exceed the following values at nominal output voltage.

Output type	Total drop	Positive line drop
V1, V2	< 0.5V	< 0.25V

### Powerfail & LED

A FAIL signal (open collector) indicate the working state of the psu.  
 The signal is open when all outputs voltage are in their range and "0" if one output is out of range.

A single bi-color LED in the front panel indicates :

- Green : Input OK
- Red : output failure

Output	Minimum value	Maximum value
+5V	4,40V	5,55V
+3V3	2,99V	3,65V
+12V	10,7V	13,2V
-12V	-10,7V	-13,1V

### Enable & IPMB\_PWR

EN# signal activates the psu when connected to ground.  
 IPMB\_PWR goes high when 5V output is OK

### output noise V3

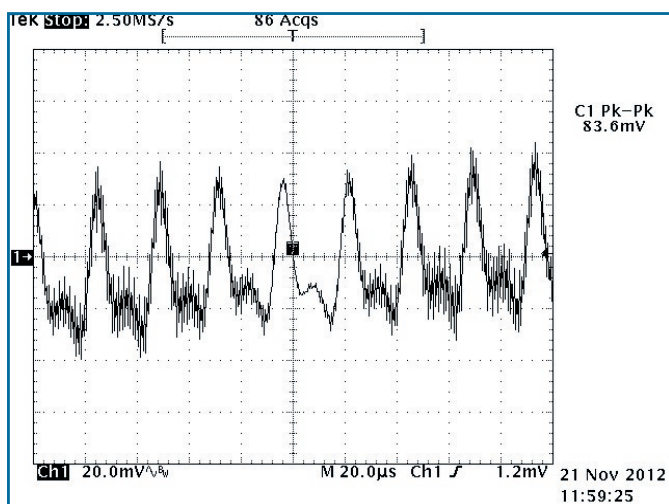

## Waveforms

### output noise V1

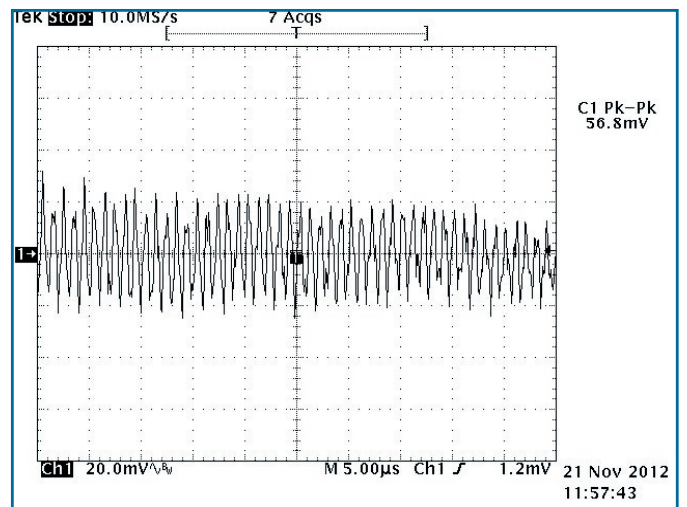

### output noise V2

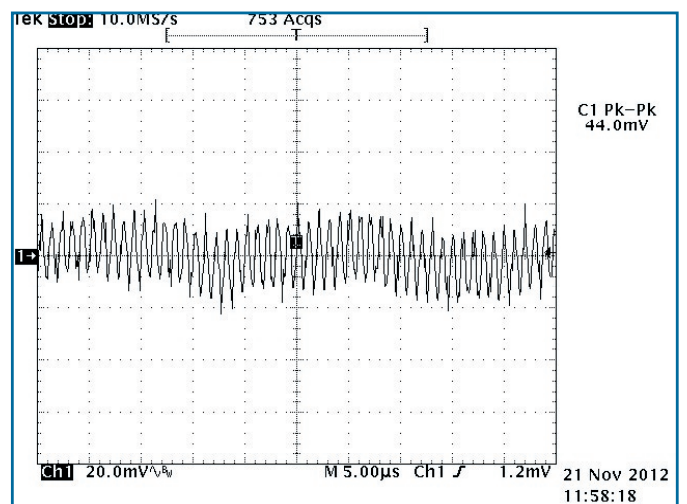

### output noise V4

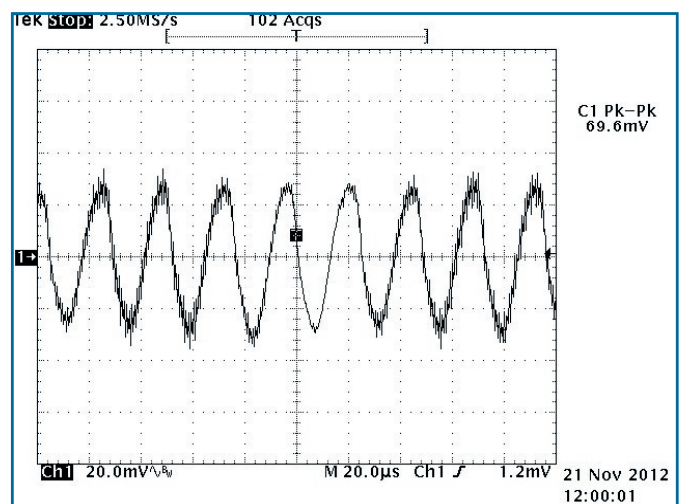

## Electromagnetic

### Electromagnetic Immunity

		Standard	Level	Value	Waveform	Source imped.	Test procedure	Mode	Criteria	
Surges	Qualified	EN 61000-4-5	DM	1KV	1,2 / 50 $\mu$ s	12 ohms		OP	B	
			CM	3	2KV	1,2 / 50 $\mu$ s	12 ohms		OP	B
			CM		2KV	1,2 / 50 $\mu$ s	12 ohms	Y option	OP	A
Electrostatic discharge (to case)	Qualified	EN 6100-4-2	4	8000V	1 / 50 $\mu$ s	330 Ohms	10 pos., 10neg.	OP	B	
Electrical fast transients/burst	Qualified	EN 61000-4-4	4	4000V	5 / 50 $\mu$ s	50 ohms		OP	B	

Note : Qualified for EN 61000-4 -2, -3, -4, -5, -6, -11, EN 61000-3-2, EN 61000-3-3

### Electromagnetic Emissions

Level according to EN55022A

MIL-STD461E CE102 M option

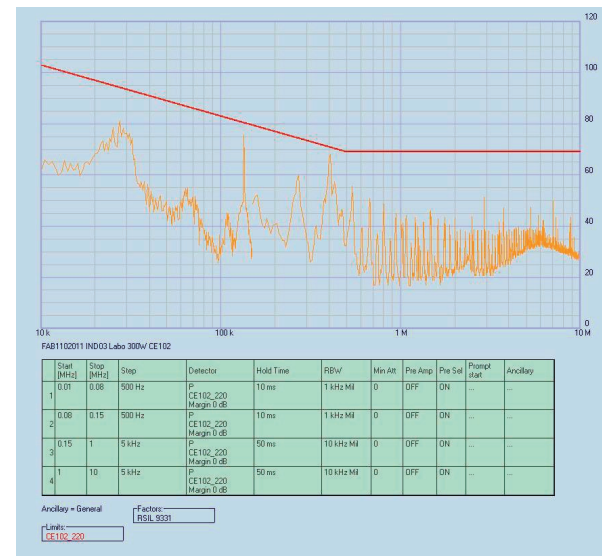
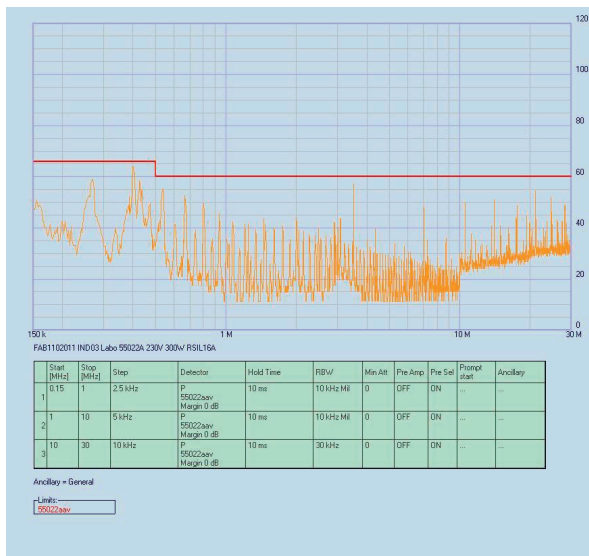

### Immunity to Environmental Conditions

Test method	Standard	Test conditions	Status
Damp Heat	MIL STD 810F Proc. 507-2	Humidity 93 %, 40°C, 56 days	Conformal coating option only (V), qualified
Shock	MIL STD 810F Proc.516.3	20g / 18ms half size 5g / 30ms	Qualified
Vibrations	MIL STD 810F Proc. 514-5	4-80Hz (2,8m/s <sup>2</sup> )/Hz, non operating 160-500Hz (0,175m/s <sup>2</sup> )/Hz, non operating	Qualified
	MIL STD 167A-1A	Non operating	Qualified

**Mechanical data**

Size : 3U x 8TE x 160mm

Solder side of the PCB protected by PBT sheet.

Weight : 600g

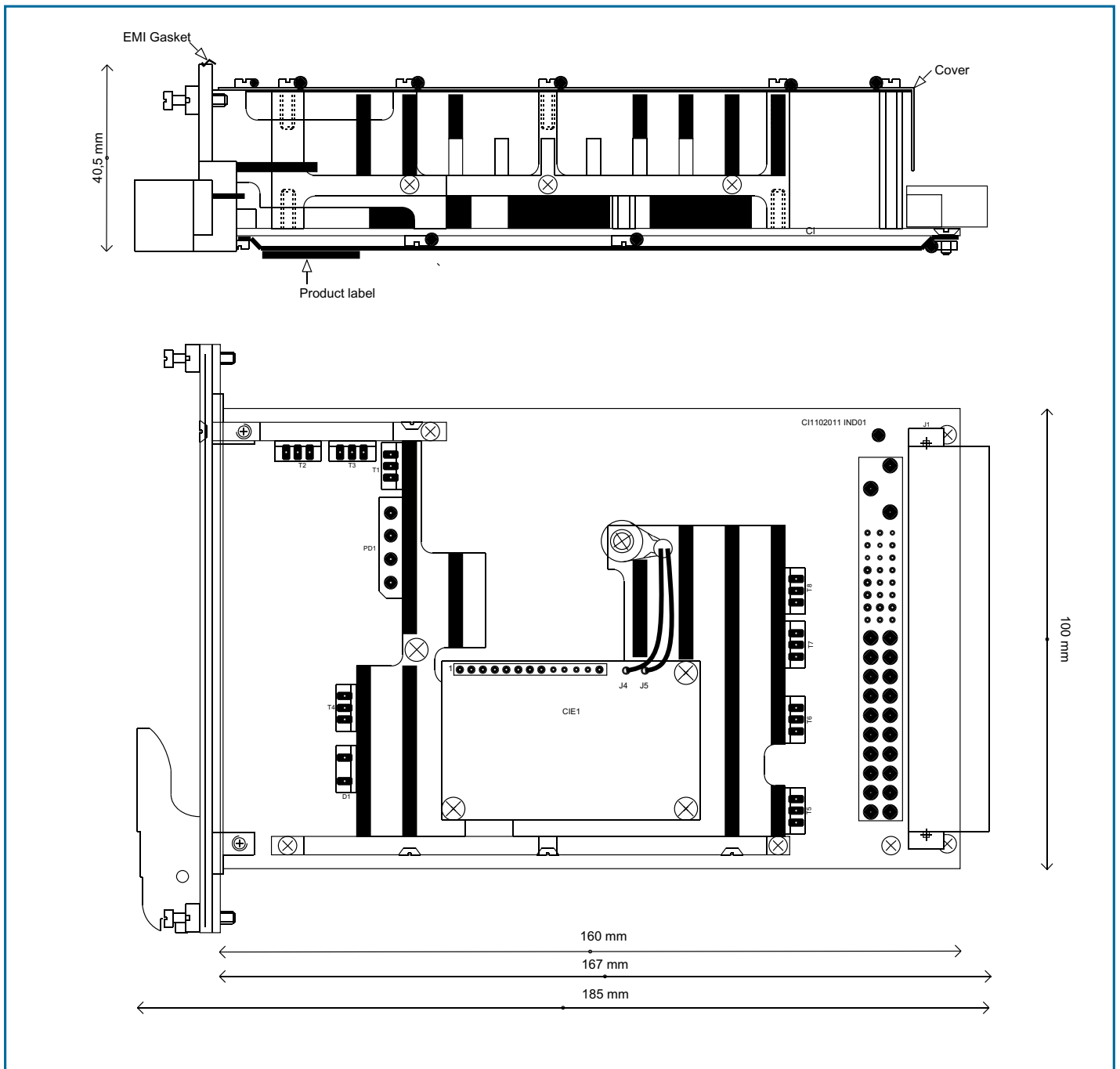



## ▼ Connector Pin Allocation

### Positronic 47 pts

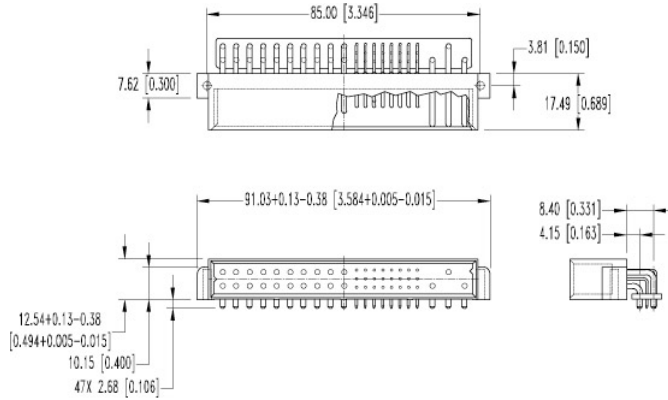

Positronic PCIH47M400A1/AA		
PIN	Description	
1, 2, 3, 4	V1	Output 1 +
5, 6, 7, 8, 9, 10, 11, 12, 19, 22, 24	RTN	Outputs 0V
13, 14, 15, 16, 17, 18	V2	Output 2 +
20	V3	Output 3+
21	V4	Output 4-
23, 25, 26, 28, 29, 31, 32, 36, 37, 40, 44	NC	Not Connected
27	EN#	Enable
30	V1 SENSE	Remote sense V1+
33	V2 SENSE	Remote sense V2+
34	S RTN	Remote sense 0V
35	V1 SHARE	Current sharing V1
38	DEG	Degrade mode signal
39	INH	Inhibition
41	V2 SHARE	Current sharing V2
42	FAIL	Signal Fail
43	IPMB_PWR	
45	EARTH	Earth
46	AC/N	AC Neutral
47	AC/L	AC Line

## Safety & Installation

These converters are components, intended exclusively for integration into other equipment by an industrial assembly process or by a professionally competent person. Installation must strictly follow the safety regulations in respect of the enclosure, mounting, creepage and clearance distances, markings of the end-use application.

Connection to the system shall be made via the female connector Positronic.

Pin 45 (Earth) is a leading pin and is connected to the case. For safety reasons it is essential to connect this pin to the protective earth of the supply system.

The AC/L is internally fused. This fuse is designed to protect the converter against overcurrent caused by a failure, but may not be able to satisfy all requirements. External fuses in the wiring circuit to one or both input pins (46 or 47) may be necessary to ensure compliance with local requirements.

Do not open the converters, or the warranty will be invalidated. Make sure that there is sufficient airflow available for convection cooling. This should be verified by measuring the case of temperature at the specified measuring point, when the converter is operated in the end-use

## Standards and Approvals

The converters are built to meet the safety standards IEC 60950-1, EN 60950-1.

'Built to meet' mentioned in the different paragraphs of the datasheet means that Power System Technology has designed the product to meet the standard but not certified it in a laboratory.

'Qualified' means that the test has been made in a certified laboratory.

## Electric Strength

Characteristic		Input to Earth	Input to Output	Output to Earth	Output to Output	Unit
Electric strength	Design strength	1500	3000	500		Vrms
	Factory test for production units (>10s)	2000	2000	500		Vdc
Insulation resistance				> 100	>100	Mohms

Note : If Y option is choosen, do not apply dielectric test.

## Temperatures

Conditions		Standard			T option			Unit
		Min.	Typ.	Max.	Min.	Typ.	Max.	
Ambiant	Operating (see derating)	-20		+71	-40		+71	°C
Heatsink		-20		+100	-40		+100	
Storage	Not operating	-40		+125	-40		+125	

## Reliability

MIL-HDBK-217F, notice 2	Model	Heatsink Temp.	GB	GF
MTBF ( Hours)	CPCIAC	40°C	285000	165000
		70°C	139500	82300
		100°C	86600	51000

## Cleaning Agents and Process

The converters are not hermetically sealed. In order to avoid possible damage, any penetration of liquids shall be avoided.

## Isolation

The electric strength test is performed in the factory in accordance with IEC/EN 60950.

## Options and configurations

Max. power available : 300W  
IN max : see table page 2

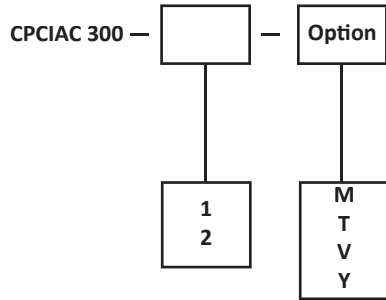

1 : 3,3V/50A, 5V/40A, 12V/1A, -12V/1A  
2 : 3,3V/50A, 5V/40A, 12V/5A, -12V/1A consult factory

CPCIDC consult factory

## ANSPRECHPARTNER



Für Fragen stehe ich Ihnen gerne persönlich zur Verfügung,

+43 (676) 466 466 0

od. per E-Mail

[robert.glaser@glaser-eng.com](mailto:robert.glaser@glaser-eng.com) .

Anfragen nehmen wir gerne unter der E-Mail-Adresse

[info@glaser-eng.com](mailto:info@glaser-eng.com)

entgegen.



Y o u r t h o u g h t i s o u r p a s s i o n !

[info@glaser-eng.com](mailto:info@glaser-eng.com)

[www.glaser-eng.com](http://www.glaser-eng.com)