

# YB-TG240240C02D-C-A0

1,3" | 240\*240 pixels | 320cd/m<sup>2</sup> | CTP



**PRODUCTCARD**

## IHR VORTEIL - UNSERE STÄRKEN

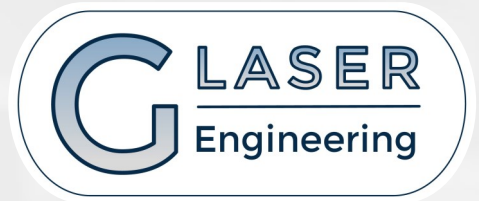

- Asiatischer Premium Hersteller (seit 1988) unter Berücksichtigung von ISO 9001, ISO 14001, IATF16949 und AEO Certificate.
- Qualitätssystem IECQ QC 080000 und ANSI/ESD S20.0.-2021
- **Individualisierung** nach Kundenwunsch (Custom Size, Custom Print, Curved, Edge-Less, Edge-Round, etc.), bzw. Anpassung von Formfaktor, Konnektivität und Leistung möglich.
- **TFT** (Thin-Film Transistor-Display) und **CTP** (Capacitive Touch Panel)  
**LCM** (Liquid Crystal Modul)  
**LCD** (Liquid Crystal Display)
- Industrie und Automotiv - Varianten
- Lange Produktverfügbarkeit
- **Standard** TFT + CTP Displays in den Größen von 1,33“ bis 15,6“.
- Kundenspezifisch ab 1,33“ bis 15,6“
- Kurze Lieferkette für Standard Displays - prompt verfügbar mittels Lager innerhalb Europas.
- Kundenreferenzen: ABB, Bayer & Bayer, brother, DeLonghi, Fisher&Paykei, Honeywell, HP, Philips, LG, Siemens, T-Mobile, etc..
- Design-In, Vertrieb und Abnahme durch das Ingenieurbüro **GLASER Engineering**



# SPECIFICATION FOR CTP MODULE

MODULE NO: YB-TG240240C02D-C-A0

**Doc.Version:02**

Customer Approval:

|                                 |                                 |
|---------------------------------|---------------------------------|
| <input type="checkbox"/> Accept | <input type="checkbox"/> Reject |
|---------------------------------|---------------------------------|

| YEEBO    | NAME                | SIGNATURE | DATE   |
|----------|---------------------|-----------|--|
| Prepare  | Mechanical Engineer | 陈长石       | 2022/9/27  |
| Check    | Electronic Engineer | 张北北       | 2022/9/27  |
| Verify   |                     |           |  |
| Approval |                     | 孙五南       | <div style="border: 1px solid green; padding: 2px; display: inline-block;">APPROVED<br/>Sunray, 2022/9/28, 8:41:16</div> |

APPROVAL FOR SPECIFICATIONS ONLY

APPROVAL FOR SPECIFICATIONS AND SAMPLE

WIMRD005-02-C



## **2. Table of Contents:**

| <b>NO</b> | <b>CONTENTS</b>                        | <b>PAGE</b> |
|-----------|--|-------------|
| 1         | Revision History                       | 1           |
| 2         | Table of Contents                      | 2           |
| 3         | Module Numbering System                | 3           |
| 4         | General Specification                  | 4           |
| 5         | Module drawing                         | 5           |
| 6         | Module Interface                       | 6           |
| 7         | Electrical specification               | 7           |
| 8         | Optical Specifications                 | 11          |
| 9         | Block Diagram:                         | 13          |
| 10        | Backlight                              | 14          |
| 11        | Standard Specification for Reliability | 15          |
| 12        | Specification of Quality Assurance     | 17          |
| 13        | Handling Precaution                    | 24          |
| 14        | Warranty                               | 25          |
| 15        | Guarantee                              | 25          |

**3. Module Numbering System:**  
**Module Numbering System:**

**YB-TG 240240 C 02 D - C - A0**

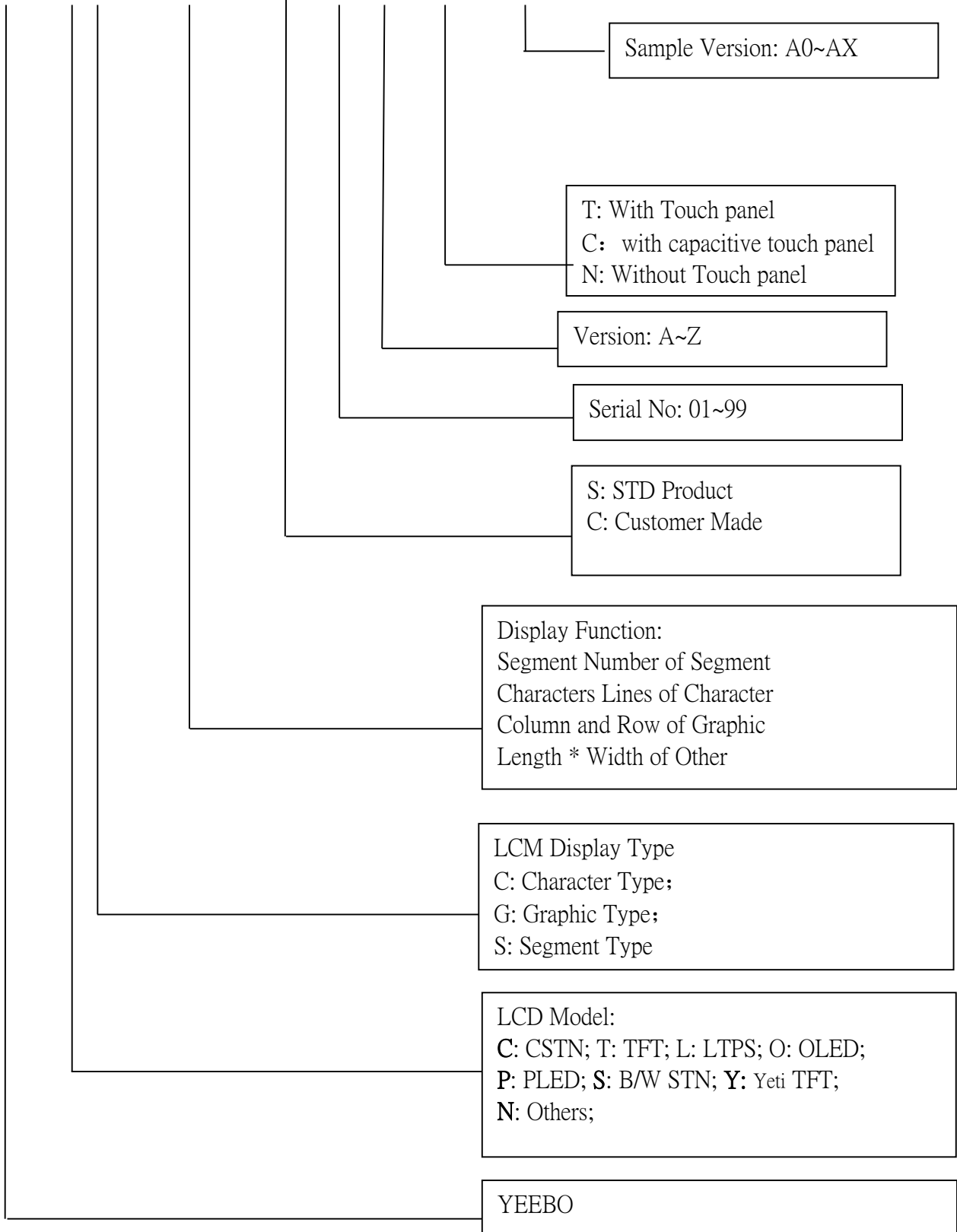

#### **4. General Specification:**

| ITEM                   | CONTENTS                                 |
|------------------------|--|
| Module Size            | 33.66(W) *38.59(H) * 2.375(T) mm         |
| Display Size(Diagonal) | 1.3inch                                  |
| Display Format         | 240 (RGB)* 240 Pixels                    |
| View Area              | 23.8 (W) *23.8(H) mm                     |
| Active Area            | 23.4(W) *23.4(H) mm                      |
| LCD Type               | TFT (262K)/ Trans missive / Normal Black |
| Viewing Direction      | Free                                     |
| TFT Controller IC      | ST7789H2                                 |
| CTP Controller IC      | ST1615                                   |
| CTP Surface Hardness   | >6H                                      |
| Weight(g)              | ≈ 4.52                                   |
| Firmware               | 9706-20220407-ST1615_FW5238.dump         |
| Test Configuration     | 9706-FW5238_20220407_144434.prj          |

### 5. Module drawing:

|  |                              |
|--|------------------------------|
| Count drawing & Spec revision record during discussion with customer |                              |
| Rec:   | Revision content description |
| 01   | FIRST ISSUE                  |
| 02   | Modify TFT-FPC               |
| Date   | 2022-1-05                    |
| Date   | 2022-2-11                    |

Customer Model

- Specification:
- Glass material: soda-lime glass(0.7mm)
  - 1.3"IPS, 240(H)\*240(V). Display colors:262k, view Direction:80/80/80/80  
Laminace Typ:320cd/m2(300-500)
  - Main LCD Driver IC:ST7789H2
  - Backlight :schipos leds parallel.
  - Class Type: OGS +TFT
  - Channel NO.: 5TX\*4RX
  - CTP Controller IC: ST1615
  - Operating temperature: -20°C to +70°C  
Storage temperature: -30°C to +80°C
  - Unspecified tolerance: ±0.20mm.
  - ROHS complant

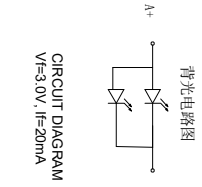
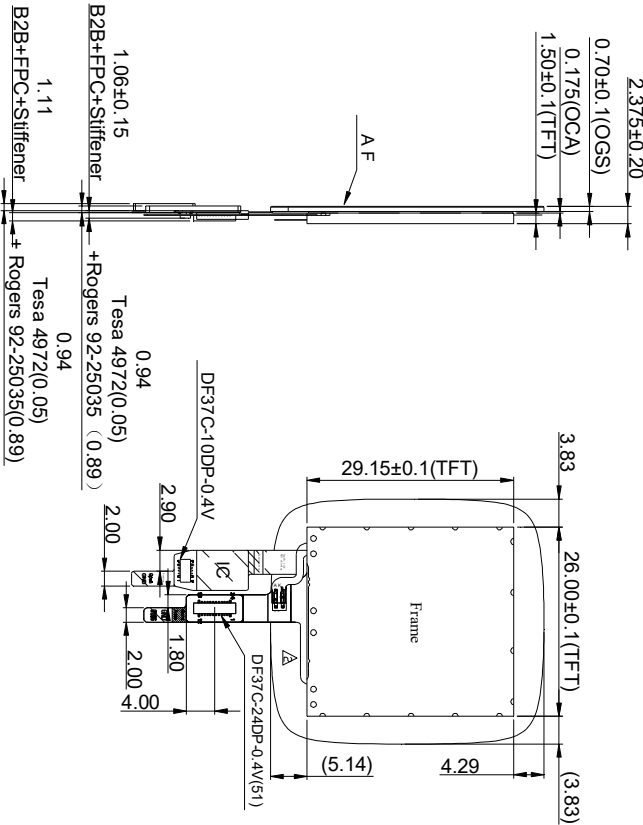
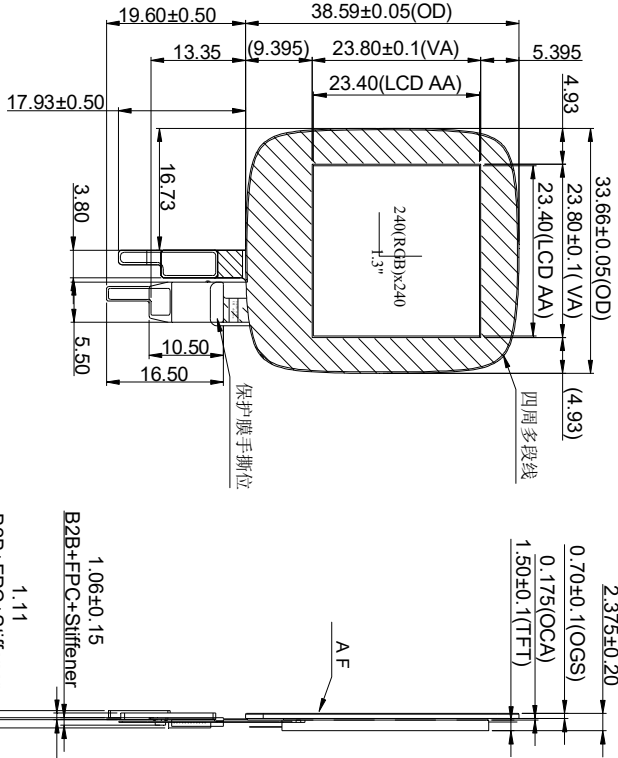

Pin 引脚定义

| Pin | Pin Define |
|-----|------------|
| 1   | GND        |
| 2   | SCL(2.8V)  |
| 3   | SDA(2.8V)  |
| 4   | HS12.8V)   |
| 5   | GND        |
| 6   | NC(2.8V)   |
| 7   | NC         |
| 8   | VDD(2.8V)  |
| 9   | VDD(2.8V)  |
| 10  | GND        |

|  |  |      |      |       |                     |          |         |          |          |           |            |    |
|--|--|------|------|-------|---------------------|----------|---------|----------|----------|-----------|------------|----|
|  |  | UNIT | SIZE | SCALE | MOD. NO.            | DESIGNED | CHECKED | VERIFIED | APPROVED | FILE NAME | Sheet      | 1  |
|  |  | mm   | A4   | N-T-S | YB-TG240240C02D-C-A |          |         |          |          |           | COUNT DWG. | Of |

| PIN | Pin Define  |
|-----|-------------|
| 1   | LED LED+    |
| 2   | LED LED+    |
| 3   | LED LED+    |
| 4   | LED LED-    |
| 5   | LED LED-    |
| 6   | LED LED-    |
| 7   | GND         |
| 8   | VDD(2.8V)   |
| 9   | VDD(2.8V)   |
| 10  | VDD(2.8V)   |
| 11  | GND         |
| 12  | GND         |
| 13  | VDDIO(1.8V) |
| 14  | VDDIO(1.8V) |
| 15  | GND         |
| 16  | GND         |
| 17  | LED CS      |
| 18  | LED SDIN    |
| 19  | LED SOLK    |
| 20  | GND         |
| 21  | LED RS      |
| 22  | LED RST     |
| 23  | GND         |
| 24  | LED TE      |

Customer Approval



## 6 Module Interface

### 6.1 TFT module interface

| NO    | SYMBOL | FUNCTION  |
|-------|--------|---|
| 1     | LEDA   | LED Anode   |
| 2     | LEDA   | LED Anode   |
| 3     | LEDA   | LED Anode   |
| 4     | LEDK   | LED Cathode   |
| 5     | LEDK   | LED Cathode   |
| 6     | LEDK   | LED Cathode   |
| 7     | GND    | Power Ground  |
| 8     | GND    | Power Ground  |
| 9-10  | VDD    | Power Supply for Analog, VDD_2.8V=2.4V~3.3V.  |
| 11-12 | GND    | Power Ground  |
| 13-14 | VDDIO  | Power Supply for I/O system. IOVCC=1.65V~3.3V   |
| 15-16 | GND    | Power Ground  |
| 17    | CS     | Chip selection pin; Low enable, High disable.   |
| 18    | SDA    | SPI interface input/output pin. The data is latched on the rising edge of the SCL signal.                       |
| 19    | SCL    | This pin is used to be serial interface clock.  |
| 20    | GND    | Power Ground  |
| 21    | RS     | Display data/command selection pin  |
| 22    | RES    | This signal will reset the device and it must be applied to properly initialize the chip. Signal is active low. |
| 23    | GND    | Power Ground  |
| 24    | TE     | TE-Tearing effect signal is used to synchronize mcu to frame memory.  |

### 6.2 CTP Interface

| NO | SYMBOL | FUNCTION                               |
|----|--------|--|
| 1  | GND    | Power Ground                           |
| 2  | SCL    | I2C serial clock                       |
| 3  | SDA    | I2C serial date                        |
| 4  | RST    | System reset signal input, active low  |
| 5  | GND    | Power Ground                           |
| 6  | GND    | Power Ground                           |
| 7  | INT    | Indicate coordinate data ready         |
| 8  | NC     | No connect                             |
| 9  | VDD    | Power supply, connect to 1uF capacitor |
| 10 | GND    | Power Ground                           |

## 7 ELECTRICAL SPECIFICATIONS

### 7-1 Absolute Maximum Ratings

( $T_a=25^{\circ}\text{C}$   $V_{SS}=0\text{V}$ )

| Item                  | Symbol | Min. | Type | Max. | Unit               | Remark |
|-----------------------|--------|------|------|------|--------------------|--------|
| Supply Voltage        | VDD    | -0.3 | -    | +4.6 | Volt               | Note1  |
| Supply Voltage(Logic) | VDDIO  | -0.3 | -    | +4.6 | Volt               | Note1  |
| Operating Temperature | Topr   | -20  | -    | +70  | $^{\circ}\text{C}$ | -      |
| Storage Temperature   | Tstg   | -30  | -    | +80  | $^{\circ}\text{C}$ | -      |

Note1: Absolute maximum rating is the limit value beyond which the IC maybe broken.  
They do not assure operations.

### 7.2. Operating Conditions

| Item                         | Symbol          | Unit | Condition          | Min.     | Typ e | Max.     |
|------------------------------|-----------------|------|--------------------|----------|-------|----------|
| Operating Voltage            | VDD             | V    | Operation Voltage  | 2.4      | 2.8   | 3.3      |
| Supply voltage for I/O       | VDDI            | V    | I/O Supply Voltage | 1.65     | 2.8   | 3.3      |
| Input Voltage                | V <sub>IH</sub> | V    | -                  | 0.7*VDDI | -     | VDDI     |
|                              | V <sub>IL</sub> | V    | -                  | GND      | -     | 0.3*VDDI |
| Power Supply Current for LCM | I <sub>dd</sub> | mA   | VDDI =2.8V         | -        | 6     | 9        |

### 7.3 AC Characteristics

#### 7.3.1 Serial Interface Characteristics (4-line serial):

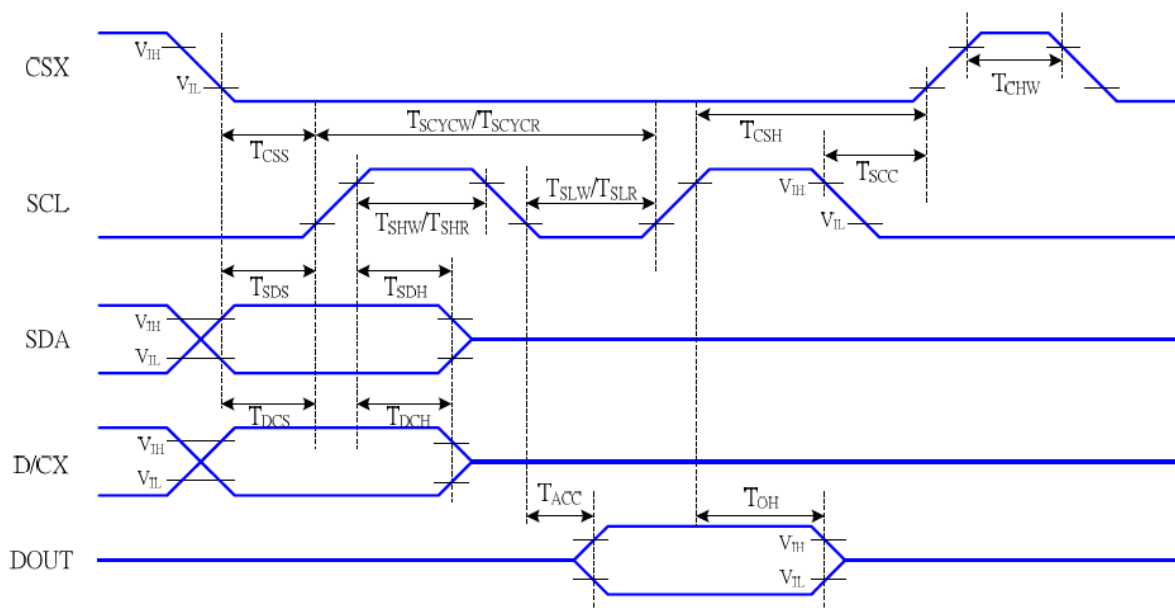

### 4-line serial Interface Timing Characteristics

(VDDI=1.65 to 3.3V, VDD=2.4 to 3.3V, AGND=DGND=0V, Ta=-30 to 70 °C)

VDDI=1.65 to 3.3V, VDD=2.4 to 3.3V, AGND=DGND=0V, Ta=-30 to 70 °C

| Signal       | Symbol             | Parameter                      | MIN | MAX | Unit | Description                  |
|--------------|--------------------|--------------------------------|-----|-----|------|------------------------------|
| CSX          | T <sub>CSS</sub>   | Chip select setup time (write) | 15  |     | ns   |                              |
|              | T <sub>CSH</sub>   | Chip select hold time (write)  | 15  |     | ns   |                              |
|              | T <sub>CSS</sub>   | Chip select setup time (read)  | 60  |     | ns   |                              |
|              | T <sub>SCC</sub>   | Chip select hold time (read)   | 65  |     | ns   |                              |
|              | T <sub>CHW</sub>   | Chip select "H" pulse width    | 40  |     | ns   |                              |
| SCL          | T <sub>SCYCW</sub> | Serial clock cycle (Write)     | 16  |     | ns   | -write command & data<br>ram |
|              | T <sub>SHW</sub>   | SCL "H" pulse width (Write)    | 7   |     | ns   |                              |
|              | T <sub>SLW</sub>   | SCL "L" pulse width (Write)    | 7   |     | ns   |                              |
|              | T <sub>SCYCR</sub> | Serial clock cycle (Read)      | 150 |     | ns   | -read command & data<br>ram  |
|              | T <sub>SHR</sub>   | SCL "H" pulse width (Read)     | 60  |     | ns   |                              |
|              | T <sub>SLR</sub>   | SCL "L" pulse width (Read)     | 60  |     | ns   |                              |
| D/CX         | T <sub>DCS</sub>   | D/CX setup time                | 10  |     | ns   |                              |
|              | T <sub>DCH</sub>   | D/CX hold time                 | 10  |     | ns   |                              |
| SDA<br>(DIN) | T <sub>SDS</sub>   | Data setup time                | 7   |     | ns   |                              |
|              | T <sub>SDH</sub>   | Data hold time                 | 7   |     | ns   |                              |
| DOUT         | T <sub>ACC</sub>   | Access time                    | 10  | 50  | ns   | For maximum CL=30pF          |
|              | T <sub>OH</sub>    | Output disable time            | 15  | 50  | ns   | For minimum CL=8pF           |

**Table 6 4-line serial Interface Characteristics**  
**4-line serial Interface Characteristics**

**Note:** The rising time and falling time (Tr, Ft.) of input signal are specified at 15 ns or less. Logic high and low levels are specified as 30% and 70% of VDDI for Input signals

## 7-4 Absolute Maximum Ratings (TP)

Table 5-1 Absolute Maximum Ratings

| Parameter                     | Symbol      | Min. | Max. | Unit |
|-------------------------------|-------------|------|------|------|
| VDD                           | $V_{VDD}$   | -0.3 | +6   | V    |
| IOVDD                         | $V_{IOVDD}$ | -0.3 | +6   | V    |
| Operating Ambient Temperature | $T_A$       | -20  | +80  | °C   |
| Storage Temperature           | $T_s$       | -40  | +125 | °C   |

**\*Note:** Stresses above those listed under "Absolute Maximum Ratings" may cause permanent damage to the device. All the ranges are stress ratings only. Functional operation of this device at these or any other conditions above those indicated in the operational sections of this specification is not implied or intended. Exposed to the absolute maximum rating conditions for extended periods may affect device reliability.

## 7-5 DC Electrical characteristics(TP)

Table 5-2 System DC Electrical Characteristics

Condition: VDD = IOVDD = 3.3V,  $T_A = 25^\circ\text{C}$ , unless be specified individually.

| Parameter              | Symbol      | Min.                  | Typ. | Max.                  | Unit | Condition                   |
|------------------------|-------------|-----------------------|------|-----------------------|------|-----------------------------|
| VDD                    | $V_{VDD}$   | 2.7                   | -    | 3.6                   | V    |                             |
| IOVDD                  | $V_{IOVDD}$ | 1.6                   | -    | 3.6                   | V    |                             |
| Operating Current      | $I_{NML}$   | -                     | 2.8  | -                     | mA   |                             |
| Idle Current           | $I_{IDLE}$  | -                     | 900  | -                     | uA   |                             |
| Smart Wake Up Current  | $I_{SWU}$   | -                     | 105  | -                     | uA   |                             |
| Power Down Current     | $I_{PD}$    | -                     | -    | 20                    | uA   |                             |
| Input High Voltage     | $V_{IH}$    | $0.85 \cdot I_{OVDD}$ | -    | -                     | V    |                             |
| Input Low Voltage      | $V_{IL}$    | -                     | -    | $0.15 \cdot I_{OVDD}$ | V    |                             |
| Input Pull Up Resistor | $R_{PU}$    | 50                    | -    | 60                    | KOhm |                             |
| Output Driving Current | $I_{DRV}$   | 6                     | -    | -                     | mA   | $V_{OH} = IOVDD \times 0.8$ |
| Output Sinking Current | $I_{SINK}$  | 10                    | -    | -                     | mA   | $V_{OL} = IOVDD \times 0.2$ |
| Low Voltage Reset      | $V_{LVR}$   | -                     | -    | 2.3                   | V    |                             |

## 7-6 AC Electrical Characteristics(TP)

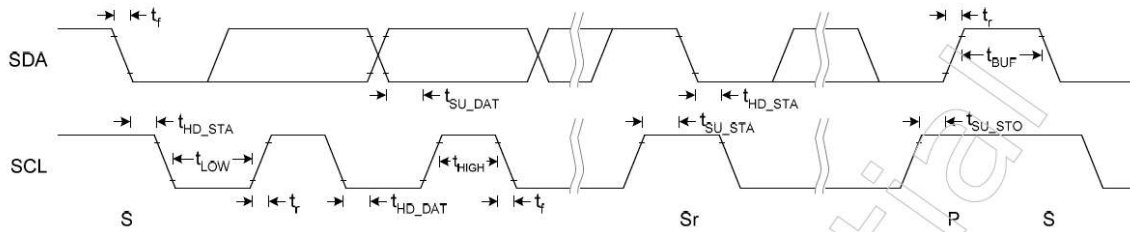

Figure 5-1 I2C Fast Mode Timing

Conditions: VDD = 3.3V, GND = 0V, T<sub>A</sub> = 25°C

| Symbol              | Parameter   | Rating |      |      | Unit |
|---------------------|---|--------|------|------|------|
|                     |   | Min.   | Typ. | Max. |      |
| f <sub>SCL</sub>    | SCL clock frequency   | 0      | -    | 400  | kHz  |
| t <sub>LOW</sub>    | Low period of the SCL clock   | 1.3    | -    | -    | us   |
| t <sub>HIGH</sub>   | High period of the SCL clock  | 0.6    | -    | -    | us   |
| t <sub>f</sub>      | Signal falling time   | -      | -    | 300  | ns   |
| t <sub>r</sub>      | Signal rising time  | -      | -    | 300  | ns   |
| t <sub>SU_STA</sub> | Set up time for a repeated START condition  | 0.6    | -    | -    | us   |
| t <sub>HD_STA</sub> | Hold time (repeated) START condition. After this period, the first clock pulse is generated | 0.6    | -    | -    | us   |
| t <sub>SU_DAT</sub> | Data set up time  | 100    | -    | -    | ns   |
| t <sub>HD_DAT</sub> | Data hold time  | 0      | -    | 0.9  | us   |
| t <sub>SU_STO</sub> | Set up time for STOP condition  | 0.6    | -    | -    | us   |
| t <sub>BUF</sub>    | Bus free time between a STOP and START condition  | 1.3    | -    | -    | us   |
| C <sub>b</sub>      | Capacitive load for each bus line   | -      | -    | 400  | pF   |

## 8. Optical Specifications

| Item                       | Symbol | Conditions                               | Specifications |      |     | Unit | Note    |   |
|----------------------------|--------|--|----------------|------|-----|------|---------|---|
|                            |        |  | Min            | Typ  | Max |      |         |   |
| Transmittance<br>(With PL) | T(%)   | -  | 3.65           | 4.3  | -   | -    | -       |   |
| Contrast Ratio             | CR     | $\Theta=0$<br>Normal<br>Viewing<br>Angle | 800            | 1200 | -   | -    | (1) (2) |   |
| Response time              | TR+TF  | -  | -              | 30   | 35  | ms   | (1) (3) |   |
| NTSC                       | %      | -  | 45             | 50   | -   | -    | -       |   |
| Viewing<br>angle           | Hor    | $\Theta_{x+}$                            | CR $\geq$ 10   | 70   | 80  | -    | deg.    | - |
|                            |        | $\Theta_{x-}$                            |                | 70   | 80  | -    |         |   |
|                            | Ver    | $\Theta_{y+}$                            |                | 70   | 80  | -    |         |   |
|                            |        | $\Theta_{y-}$                            |                | 70   | 80  | -    |         |   |

### Measuring Condition

1. Measuring surrounding: dark room
2. Ambient temperature: 25 $\pm$ 2 $^{\circ}$ C
3. 30 min. Warm-up time.

Color of CIE Coordinate:

| Item  | Symbol | Condition | Min.   | Typ.  | Max.  |       |
|---|--------|-----------|--|-------|-------|-------|
| Chromaticity<br>Coordinates<br>(Transmissive) | Red    | x         | $\theta = \phi = 0^{\circ}$<br>LED Backlight | 0.538 | 0.588 | 0.638 |
|   |        | y         |  | 0.275 | 0.325 | 0.375 |
|   | Green  | x         |  | 0.275 | 0.325 | 0.375 |
|   |        | y         |  | 0.487 | 0.537 | 0.587 |
|   | Blue   | x         |  | 0.104 | 0.154 | 0.204 |
|   |        | y         |  | 0.035 | 0.085 | 0.135 |
|   | White  | x         |  | 0.254 | 0.304 | 0.354 |
|   |        | y         |  | 0.277 | 0.327 | 0.377 |

Note (1) Definition of Viewing Angle :

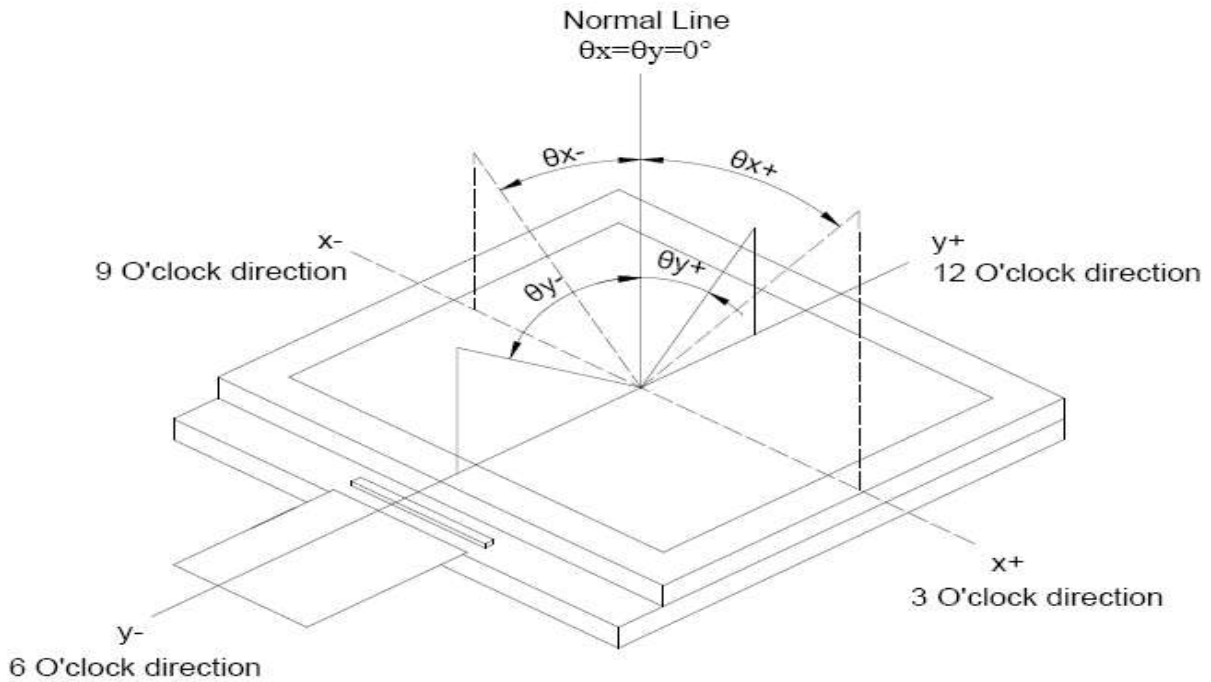

Note (2) Definition of Contrast Ratio(CR) :  
measured at the center point of panel

$$\text{Contrast ratio (CR)} = \frac{\text{Photo detector output when LCD is at "White" state}}{\text{Photo detector output when LCD is at "Black" state}}$$

Note (3) Definition of Response Time : Sum of  $T_R$  and  $T_F$

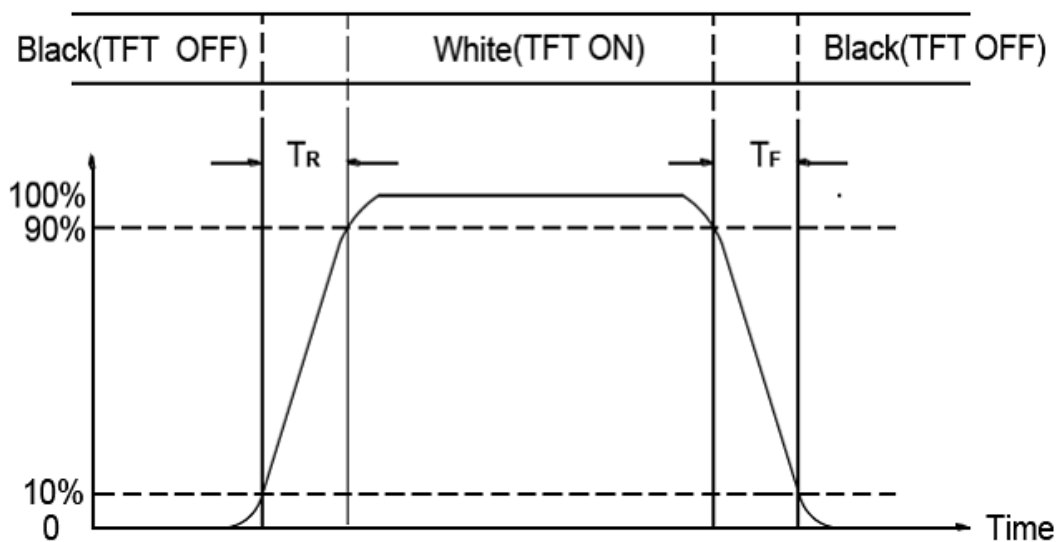

**9. Block Diagram:**

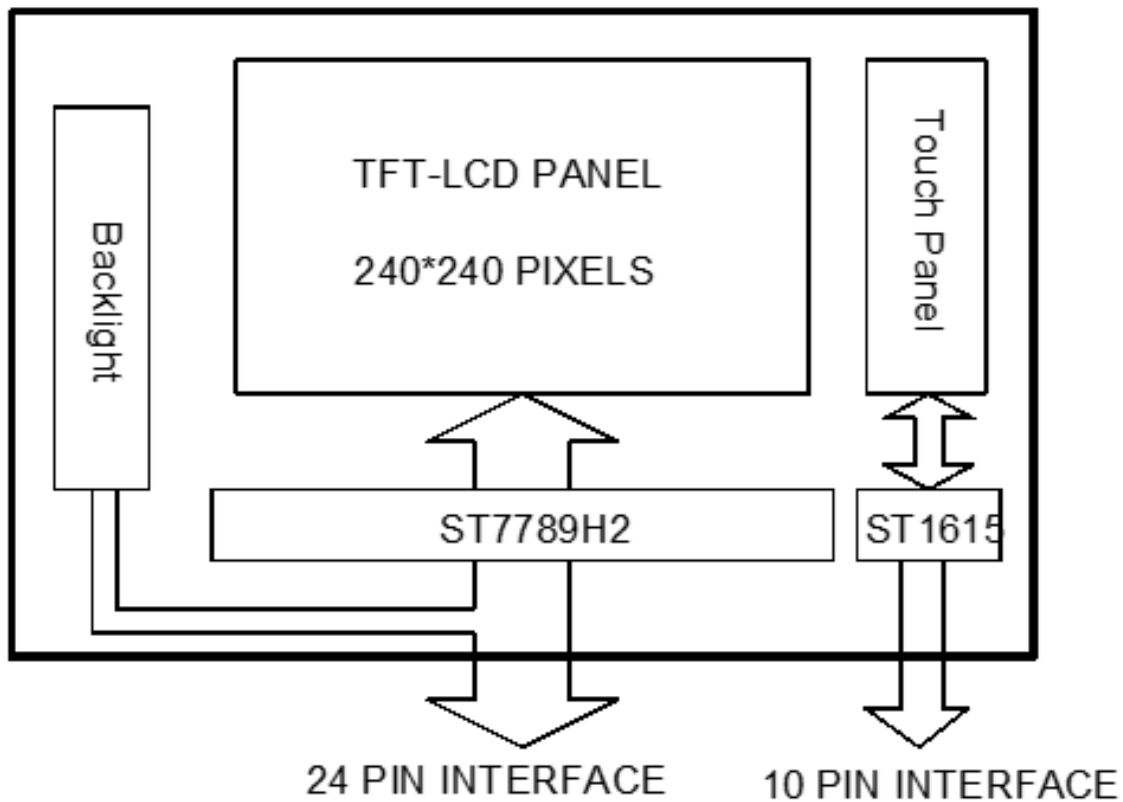



## 10. Backlight:

### 1. Standard Lamp Styles (Edge Lighting Type):

The LED chips are distributed over the edge light area of the illumination unit, which gives the less power consumption:

### 2. The Main Advantages of the LED Backlight are as following:

2.1 The brightness of the backlight can simply be adjusted.

By a resistor or a potentiometer.

### 3. Data About LED Backlight:

(Ta=25°C)

| PARAMETER                      | Sym.  | Min.  | Typ. | Max. | Unit              | Test Condition | Note |
|--------------------------------|-------|-------|------|------|-------------------|----------------|------|
| Supply Current                 | I     | -     | 20   | -    | mA                |                |      |
| Supply Voltage                 | V     | 2.8   | 3.1  | 3.4  | V                 | If=20mA        |      |
| Luminous Intensity for LCM+CTP | IV    | 200   | 260  | -    | Cd/m <sup>2</sup> | If=20mA        | 2    |
| Uniformity for LCM             | -     | 70    | -    | -    | %                 |                | 3    |
| Life Time                      | -     | 20000 | -    | -    | Hr.               |                | 4    |
| Color                          | White |       |      |      |                   |                |      |

NOTE:

1. Backlight Only

2. Average Luminous Intensity of P1-P5

3. Uniformity = Min/Max \* 100%

4. LED life time defined as follows: The final brightness is at 50% of original brightness

**Measured Method: (X\*Y: Light Area)**

**Internal Circuit Diagram**

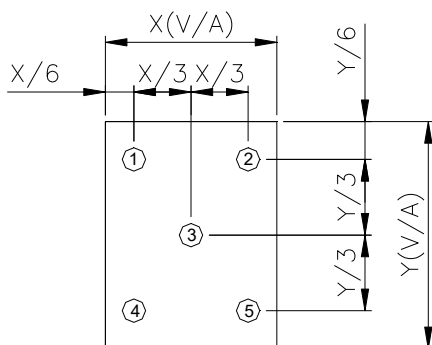

**Circuit Diagram(LED 2 PCS)**

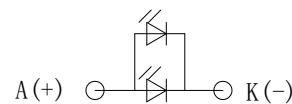

**(Effective spatial Distribution)**

Using aperture of 1°, distance 50cm.

## 11. Standard Specification for Reliability :

### 11-1. Standard Specifications for Reliability of LCD Module

| No | Item                       | Description   |
|----|----------------------------|---|
| 01 | High temperature operation | The sample should be allowed to stand at 70°C for 120 hours under driving condition and then returning it to normal temperature condition, and allowing it stand for 2 hours.                       |
| 02 | Low temperature operation  | The sample should be allowed to stand at -20°C for 120 hours under driving condition and then returning it to normal temperature condition, and allowing it stand for 2 hours.                      |
| 03 | High temperature storage   | The sample should be allowed to stand at 80°C for 240 hours under no-load condition, and then returning it to normal temperature condition, and allowing it stand for 2 hours.                      |
| 04 | Low temperature storage    | The sample should be allowed to stand at -30°C for 240 hours under no-load condition, then returning it to normal temperature condition, and allowing it stand for 2 hours.                         |
| 05 | Moisture storage           | The sample should be allowed to stand at 60°C,90%RH MAX for 240 hours under no-load condition, then taking it out and drying it at normal temperature for 2 hours.                                  |
| 06 | Thermal shock storage      | The sample should be allowed to stand the following 10 cycles :<br>-30°C for 30 minutes → normal temperature for 5 minutes → +80°C for 30 minutes → normal temperature for 5 minutes, as one cycle. |
| 07 | Packing vibration          | Frequency range : 10Hz ~ 55Hz<br>Amplitude of vibration : 1.5mm      Sweep time: 12 min<br>X,Y,Z 2 hours for each direction.  |
| 08 | Packing drop test          | According to ISTA 1A 2001.  |

\*Sample size for each test item is 3~5pcs

## 11 - 2. Testing Conditions and Inspection Criteria

For the final test the testing sample must be stored at room temperature for 24 hours, after the tests listed in Table 12.1, Standard specifications for Reliability have been executed in order to ensure stability.

| No | Item                | Test Model             | In section Criteria  |
|----|---------------------|------------------------|--|
| 01 | Current Consumption | Refer To Specification | The current consumption should conform to the product specification.   |
| 02 | Contrast            | Refer To Specification | After the tests have been executed, the contrast must be larger than half of its initial value prior to the tests. |
| 03 | Appearance          | Visual inspection      | Defect free.   |

## 11- 3. MTBF

|      |   |
|------|---|
| MTBF | Functions, performance, appearance, etc. shall be free from remarkable deterioration within 50,000 hours under ordinary operating and storage conditions room temperature ( $25\pm 5^{\circ}\text{C}$ ), normal humidity ( $50\pm 10\%$ RH), and in area not exposed to direct sun light. |
|------|---|

## 12. Specification of Quality Assurance:

### 12-1. Purpose

This standard for Quality Assurance should affirm the quality of LCD module products to supply to purchaser by YEEBO CORPORATION (Supplier).

### 12-2. Standard for Quality Test

#### a. Inspection:

Before delivering, the supplier should take the following tests, and affirm the quality of product.

#### b. Electro-Optical Characteristics:

According to the individual specification to test the product.

#### c. Test of Appearance Characteristics:

According to the individual specification to test the product.

#### d. Test of Reliability Characteristics:

According to the definition of reliability on the specification for testing products.

#### e. Delivery Test:

Before delivering, the supplier should take the delivery test.

(i) Test method: According to **ISO2859-1**.General Inspection Level II take a single time.

(ii) The defects classify of AQL as following:

Major defect: AQL = 0.65

Minor defect: AQL = 2.5

Total defects: AQL = 2.5

### 12-3. Non- conforming Analysis & Deal With Manners

#### a. Non- conforming Analysis:

(i) Purchaser should supply the detail data of non- conforming sample and the non-conforming.

(ii) After accepting the detail data from purchaser, the analysis of non- conforming should be finished in two weeks.

(iii) If supplier can not finish analysis on time, must announce purchaser before 3 days.

#### b. Disposition of non- conforming:

(i) If find any product defect of supplier during assembly time, supplier must change the good product for every defect after recognition.

(ii) Both supplier and customer should analyze the reason and discuss the disposition of non- conforming when the reason of nonconforming is not sure.

### 12-4. Agreement items

Both sides should discuss together when the following problems happen.

a. There is any problem of standard of quality assurance, and both sides should think that must be modified.

b. There is any argument item which does not record in the standard of quality assurance.

c. Any other special problem.

12-5. Standard of The Product Appearance Test

a. Manner of appearance test:

- (i) The test must be under 20W × 2 or 40W fluorescent light, and the distance of view must be at 30±5cm.
- (ii) When test the model of transmissive product must add the reflective plate.
- (iii) The test direction is base on around 10° of vertical line.
- (iiii) Temperature: 25±5°C Humidity: 60±10%RH

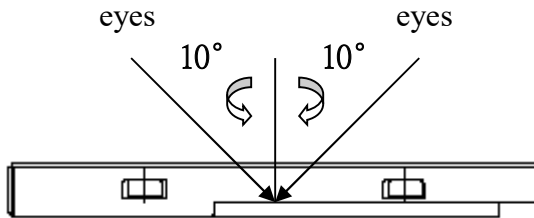

(iv) Definition of area:

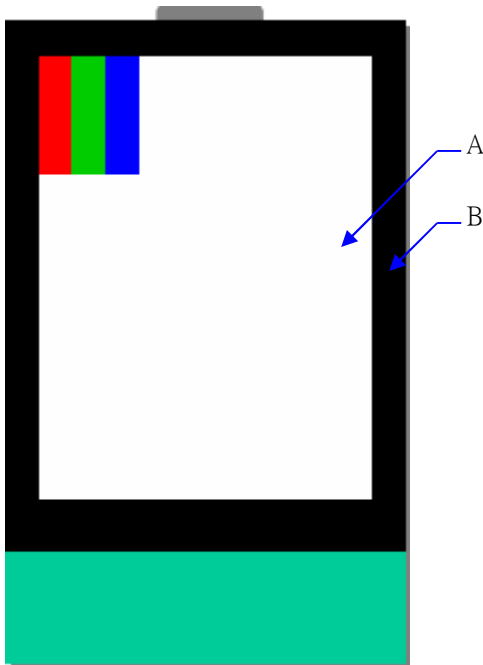

- A. Area: Viewing area.
- B. Area: Out of viewing area.  
(Outside viewing area)

b. Basic principle:

- (i) It will accord to the AQL when the standard can not be described.
- (ii) The sample of the lowest acceptable quality level must be discussed by both supplier and customer when any dispute happened.
- (iii) Must add new item on time when it is necessary.

c. Standard of inspection: (Unit: mm)

12-6. Inspection specification

Defect out of viewing area can be neglected.

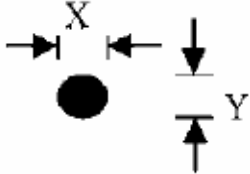
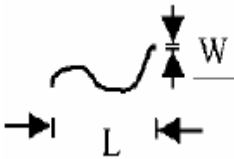
| NO  | Item  | Criterion  | AQL             |                 |                  |                 |                         |                      |                         |            |                         |     |               |           |     |
|---|---|--|-----------------|-----------------|------------------|-----------------|-------------------------|----------------------|-------------------------|------------|-------------------------|-----|---------------|-----------|-----|
| 01  | Electrical Testing  | 1.1 Missing vertical, horizontal segment, segment contrast defect.<br>1.2 Missing character, dot or icon.<br>1.3 Display malfunction.<br>1.4 No function or no display.<br>1.5 Current consumption exceeds product specifications.<br>1.6 LCD viewing angle defect.<br>1.7 Mixed product types.<br>1.8 Flicker   | 0.65            |                 |                  |                 |                         |                      |                         |            |                         |     |               |           |     |
| 02  | Black or White spots or Bright spots or Color spots on LCD (Display only)   | 2.1 White and black or color spots on display $\leq 0.25\text{mm}$ , no more than Five spots.<br>2.2 Densely spaced: No more than three spots within 3mm.<br>2.3 Not visible through 5% ND filter  | 2.5             |                 |                  |                 |                         |                      |                         |            |                         |     |               |           |     |
| 03  | LCD and Touch Panel black spots, white spots, contamination (non – display) | 3.1 Round type: As following drawing<br>$\Phi = (X+Y) / 2$  <table border="1" data-bbox="758 907 1292 1160"> <thead> <tr> <th>Size(mm)</th> <th>Acceptable Q'ty</th> </tr> </thead> <tbody> <tr> <td><math>\Phi \leq 0.10</math></td> <td>Accept no dense</td> </tr> <tr> <td><math>0.10 &lt; \Phi \leq 0.20</math></td> <td>2</td> </tr> <tr> <td><math>0.20 &lt; \Phi \leq 0.25</math></td> <td>2</td> </tr> <tr> <td><math>0.25 &lt; \Phi \leq 0.30</math></td> <td>1</td> </tr> <tr> <td><math>0.30 &lt; \Phi</math></td> <td>0</td> </tr> </tbody> </table> <p>* Densely spaced: No more than two spots within 3mm.</p> | Size(mm)        | Acceptable Q'ty | $\Phi \leq 0.10$ | Accept no dense | $0.10 < \Phi \leq 0.20$ | 2                    | $0.20 < \Phi \leq 0.25$ | 2          | $0.25 < \Phi \leq 0.30$ | 1   | $0.30 < \Phi$ | 0         | 2.5 |
|   |   | Size(mm)   | Acceptable Q'ty |                 |                  |                 |                         |                      |                         |            |                         |     |               |           |     |
| $\Phi \leq 0.10$  | Accept no dense   |  |                 |                 |                  |                 |                         |                      |                         |            |                         |     |               |           |     |
| $0.10 < \Phi \leq 0.20$   | 2   |  |                 |                 |                  |                 |                         |                      |                         |            |                         |     |               |           |     |
| $0.20 < \Phi \leq 0.25$   | 2   |  |                 |                 |                  |                 |                         |                      |                         |            |                         |     |               |           |     |
| $0.25 < \Phi \leq 0.30$   | 1   |  |                 |                 |                  |                 |                         |                      |                         |            |                         |     |               |           |     |
| $0.30 < \Phi$   | 0   |  |                 |                 |                  |                 |                         |                      |                         |            |                         |     |               |           |     |
| 3.2 Line type: (As following drawing)<br> <table border="1" data-bbox="662 1310 1292 1585"> <thead> <tr> <th>Length(mm)</th> <th>Width(mm)</th> <th>Acceptable Q'ty</th> </tr> </thead> <tbody> <tr> <td><math>L \leq 8.0</math></td> <td><math>W \leq 0.03</math></td> <td>Accept no dense</td> </tr> <tr> <td><math>L \leq 5</math></td> <td><math>0.02 &lt; W \leq 0.05</math></td> <td rowspan="2">2</td> </tr> <tr> <td><math>L \leq 5</math></td> <td><math>0.03 &lt; W \leq 0.08</math></td> </tr> <tr> <td>---</td> <td><math>0.08 &lt; W</math></td> <td>Rejection</td> </tr> </tbody> </table> <p>* Densely spaced: No more than two lines within 3mm.</p> | Length(mm)  | Width(mm)  | Acceptable Q'ty | $L \leq 8.0$    | $W \leq 0.03$    | Accept no dense | $L \leq 5$              | $0.02 < W \leq 0.05$ | 2                       | $L \leq 5$ | $0.03 < W \leq 0.08$    | --- | $0.08 < W$    | Rejection | 2.5 |
| Length(mm)  | Width(mm)   | Acceptable Q'ty  |                 |                 |                  |                 |                         |                      |                         |            |                         |     |               |           |     |
| $L \leq 8.0$  | $W \leq 0.03$   | Accept no dense  |                 |                 |                  |                 |                         |                      |                         |            |                         |     |               |           |     |
| $L \leq 5$  | $0.02 < W \leq 0.05$  | 2  |                 |                 |                  |                 |                         |                      |                         |            |                         |     |               |           |     |
| $L \leq 5$  | $0.03 < W \leq 0.08$  |  |                 |                 |                  |                 |                         |                      |                         |            |                         |     |               |           |     |
| ---   | $0.08 < W$  | Rejection  |                 |                 |                  |                 |                         |                      |                         |            |                         |     |               |           |     |

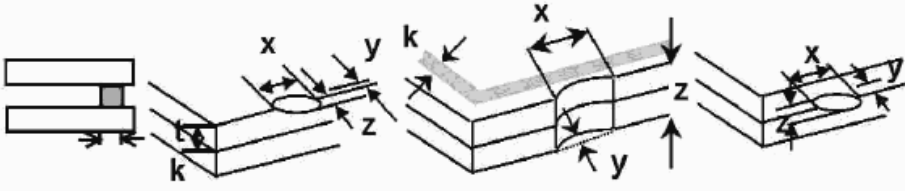
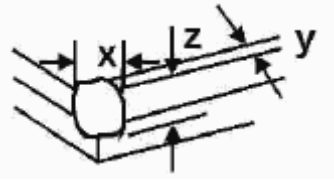
| NO                      | Item                  | Criterion  | AQL               |                 |                  |                 |                         |               |                         |                 |               |                   |               |                |               |                       |               |                    |                 |               |     |
|-------------------------|-----------------------|--|-------------------|-----------------|------------------|-----------------|-------------------------|---------------|-------------------------|-----------------|---------------|-------------------|---------------|----------------|---------------|-----------------------|---------------|--------------------|-----------------|---------------|-----|
| 04                      | Polarizer bubbles     | <p>If bubbles are visible, judge using black spot specifications, not easy to find, must check in specify direction</p> <table border="1"> <thead> <tr> <th>Size <math>\Phi</math>(mm)</th> <th>Acceptable Q'ty</th> </tr> </thead> <tbody> <tr> <td><math>\Phi \leq 0.20</math></td> <td>Accept no dense</td> </tr> <tr> <td><math>0.20 &lt; \Phi \leq 0.50</math></td> <td>3</td> </tr> <tr> <td><math>0.50 &lt; \Phi \leq 1.00</math></td> <td>2</td> </tr> <tr> <td><math>1.00 &lt; \Phi</math></td> <td>0</td> </tr> <tr> <td>Total Q'ty</td> <td>3</td> </tr> </tbody> </table>  | Size $\Phi$ (mm)  | Acceptable Q'ty | $\Phi \leq 0.20$ | Accept no dense | $0.20 < \Phi \leq 0.50$ | 3             | $0.50 < \Phi \leq 1.00$ | 2               | $1.00 < \Phi$ | 0                 | Total Q'ty    | 3              | 2.5           |                       |               |                    |                 |               |     |
| Size $\Phi$ (mm)        | Acceptable Q'ty       |  |                   |                 |                  |                 |                         |               |                         |                 |               |                   |               |                |               |                       |               |                    |                 |               |     |
| $\Phi \leq 0.20$        | Accept no dense       |  |                   |                 |                  |                 |                         |               |                         |                 |               |                   |               |                |               |                       |               |                    |                 |               |     |
| $0.20 < \Phi \leq 0.50$ | 3                     |  |                   |                 |                  |                 |                         |               |                         |                 |               |                   |               |                |               |                       |               |                    |                 |               |     |
| $0.50 < \Phi \leq 1.00$ | 2                     |  |                   |                 |                  |                 |                         |               |                         |                 |               |                   |               |                |               |                       |               |                    |                 |               |     |
| $1.00 < \Phi$           | 0                     |  |                   |                 |                  |                 |                         |               |                         |                 |               |                   |               |                |               |                       |               |                    |                 |               |     |
| Total Q'ty              | 3                     |  |                   |                 |                  |                 |                         |               |                         |                 |               |                   |               |                |               |                       |               |                    |                 |               |     |
| 05                      | Scratches             | Follow NO.3 -2 Line Type.  |                   |                 |                  |                 |                         |               |                         |                 |               |                   |               |                |               |                       |               |                    |                 |               |     |
| 06                      | Mura                  | Not visible through 5% ND filter in 50% gray.  | 2.5               |                 |                  |                 |                         |               |                         |                 |               |                   |               |                |               |                       |               |                    |                 |               |     |
| 07                      | Chipped glass         | <p>Symbols:<br/> x: Chip length            y: Chip width            z: Chip thickness<br/> k: Seal width            t: Glass thickness    a: LCD side length<br/> L: Electrode pad length</p> <p>7.1 General glass chip:<br/> 7.1.1 Chip on panel surface and crack between panels:</p>  <table border="1"> <thead> <tr> <th>z: Chip thickness</th> <th>y: Chip width</th> <th>x: Chip length</th> </tr> </thead> <tbody> <tr> <td><math>Z \leq 1/2t</math></td> <td>Not over viewing area</td> <td><math>x \leq 1/8a</math></td> </tr> <tr> <td><math>1/2t &lt; z \leq 2t</math></td> <td>Not exceed 1/3k</td> <td><math>x \leq 1/8a</math></td> </tr> </tbody> </table> <p>⊙ Unit: mm<br/> ⊙ If there are 2 or more chips, x is the total length of each chip</p> <p>7.1.2 Corner crack:</p>  <table border="1"> <thead> <tr> <th>z: Chip thickness</th> <th>y: Chip width</th> <th>x: Chip length</th> </tr> </thead> <tbody> <tr> <td><math>Z \leq 1/2t</math></td> <td>Not over viewing area</td> <td><math>x \leq 1/8a</math></td> </tr> <tr> <td><math>1/2t &lt; z \leq 2t</math></td> <td>Not exceed 1/3k</td> <td><math>x \leq 1/8a</math></td> </tr> </tbody> </table> <p>⊙ Unit: mm<br/> ⊙ If there are 2 or more chips, x is the total length of each chip</p> | z: Chip thickness | y: Chip width   | x: Chip length   | $Z \leq 1/2t$   | Not over viewing area   | $x \leq 1/8a$ | $1/2t < z \leq 2t$      | Not exceed 1/3k | $x \leq 1/8a$ | z: Chip thickness | y: Chip width | x: Chip length | $Z \leq 1/2t$ | Not over viewing area | $x \leq 1/8a$ | $1/2t < z \leq 2t$ | Not exceed 1/3k | $x \leq 1/8a$ | 2.5 |
| z: Chip thickness       | y: Chip width         | x: Chip length   |                   |                 |                  |                 |                         |               |                         |                 |               |                   |               |                |               |                       |               |                    |                 |               |     |
| $Z \leq 1/2t$           | Not over viewing area | $x \leq 1/8a$  |                   |                 |                  |                 |                         |               |                         |                 |               |                   |               |                |               |                       |               |                    |                 |               |     |
| $1/2t < z \leq 2t$      | Not exceed 1/3k       | $x \leq 1/8a$  |                   |                 |                  |                 |                         |               |                         |                 |               |                   |               |                |               |                       |               |                    |                 |               |     |
| z: Chip thickness       | y: Chip width         | x: Chip length   |                   |                 |                  |                 |                         |               |                         |                 |               |                   |               |                |               |                       |               |                    |                 |               |     |
| $Z \leq 1/2t$           | Not over viewing area | $x \leq 1/8a$  |                   |                 |                  |                 |                         |               |                         |                 |               |                   |               |                |               |                       |               |                    |                 |               |     |
| $1/2t < z \leq 2t$      | Not exceed 1/3k       | $x \leq 1/8a$  |                   |                 |                  |                 |                         |               |                         |                 |               |                   |               |                |               |                       |               |                    |                 |               |     |

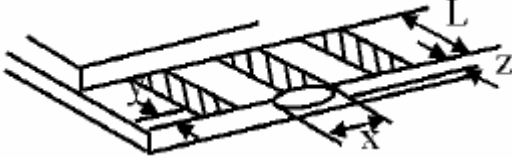
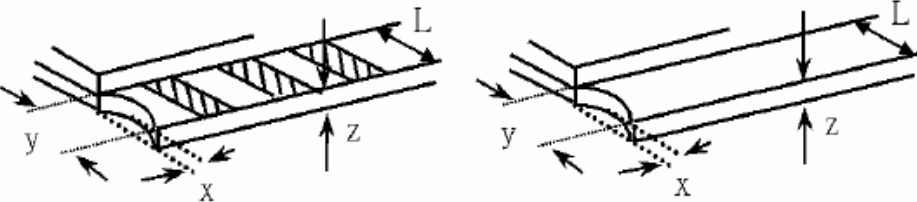
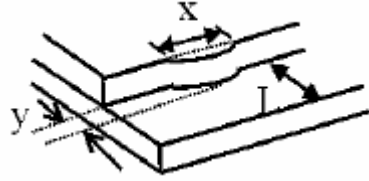
| NO                    | Item           | Criterion   | AQL           |                |                   |                       |               |                |               |                |                   |            |               |                |          |           |               |            |     |
|-----------------------|----------------|---|---------------|----------------|-------------------|-----------------------|---------------|----------------|---------------|----------------|-------------------|------------|---------------|----------------|----------|-----------|---------------|------------|-----|
| 08                    | Glass crack    | <p>Symbols:<br/>           x: Chip length            y: Chip width            z: Chip thickness<br/>           k: Seal width            t: Glass thickness    a: LCD side length<br/>           L: Electrode pad length</p> <p>8.1 Protrusion over terminal:<br/>           8.1.1 Chip on electrode pad:</p>  <table border="1" data-bbox="485 685 1171 842"> <tr> <td>y: Chip width</td> <td>x: Chip length</td> <td>z: Chip thickness</td> </tr> <tr> <td><math>y \leq 0.5\text{mm}</math></td> <td><math>x \leq 1/8a</math></td> <td><math>0 &lt; z \leq t</math></td> </tr> </table> <p>8.1.2 Non-conductive portion:</p>  <table border="1" data-bbox="485 1205 1171 1361"> <tr> <td>y: Chip width</td> <td>x: Chip length</td> <td>z: Chip thickness</td> </tr> <tr> <td><math>y \leq L</math></td> <td><math>x \leq 1/8a</math></td> <td><math>0 &lt; z \leq t</math></td> </tr> </table> <p>⊙ If there chipped area touches the ITO terminal, over 2/3 of the ITO must remain and be inspected according to electrode terminal specifications.<br/>           ⊙ If the product will be heat sealed by the customer, the alignment mark must not be damaged.</p> <p>8.1.3 Substrate protuberance and internal crack</p>  <table border="1" data-bbox="804 1675 1246 1832"> <tr> <td>y: width</td> <td>x: length</td> </tr> <tr> <td><math>y \leq 1/3L</math></td> <td><math>X \leq a</math></td> </tr> </table> | y: Chip width | x: Chip length | z: Chip thickness | $y \leq 0.5\text{mm}$ | $x \leq 1/8a$ | $0 < z \leq t$ | y: Chip width | x: Chip length | z: Chip thickness | $y \leq L$ | $x \leq 1/8a$ | $0 < z \leq t$ | y: width | x: length | $y \leq 1/3L$ | $X \leq a$ | 2.5 |
| y: Chip width         | x: Chip length | z: Chip thickness   |               |                |                   |                       |               |                |               |                |                   |            |               |                |          |           |               |            |     |
| $y \leq 0.5\text{mm}$ | $x \leq 1/8a$  | $0 < z \leq t$  |               |                |                   |                       |               |                |               |                |                   |            |               |                |          |           |               |            |     |
| y: Chip width         | x: Chip length | z: Chip thickness   |               |                |                   |                       |               |                |               |                |                   |            |               |                |          |           |               |            |     |
| $y \leq L$            | $x \leq 1/8a$  | $0 < z \leq t$  |               |                |                   |                       |               |                |               |                |                   |            |               |                |          |           |               |            |     |
| y: width              | x: length      |   |               |                |                   |                       |               |                |               |                |                   |            |               |                |          |           |               |            |     |
| $y \leq 1/3L$         | $X \leq a$     |   |               |                |                   |                       |               |                |               |                |                   |            |               |                |          |           |               |            |     |

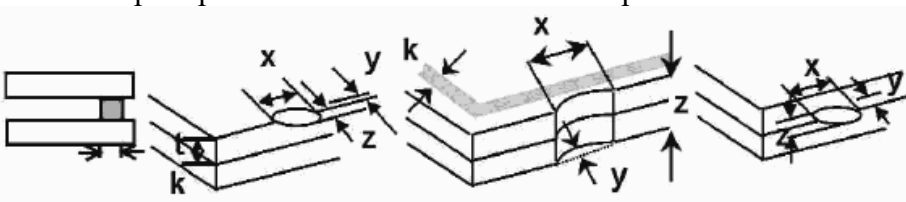

| NO | Item               | Criterion   | AQL   |
|----|--------------------|---|---|
| 09 | Cracked glass      | The LCD with extensive crack is not acceptable.   | 2.5   |
| 10 | Backlight elements | 10.1 Illumination source flickers when lit.<br>10.2 Spots or scratches that appear when lit must be judged. Using LCD spot, lines and contamination standards.<br>10.3 Backlight doesn't light or color is wrong.   | 2.5<br>2.5<br>0.65                              |
| 11 | Bezel              | Bezel must comply with product specifications.  | 2.5   |
| 12 | PCB、COB            | 12.1 COB seal may not have pinholes larger than 0.2mm or contamination.<br>12.2 COB seal surface may not have pinholes through to the IC.<br>12.3 The height of the COB should not exceed the height indicated in the assembly diagram.<br>12.4 There may not be more than 2mm of sealant outside the seal area on PCB. And there should be no more than three places.<br>12.5 Parts on PCB must be the same as on the production characteristic chart, There should be no wrong parts, missing parts or excess parts.<br>12.6 The jumper on the PCB should conform to the product characteristic chart.<br>12.7 PCBA cosmetic control base on latest IPC standard,IPC-A-610,acceptalbe limit of grade 2. | 2.5<br>2.5<br>2.5<br>2.5<br>0.65<br>0.65<br>2.5 |
| 13 | FPC                | 13.1 FPC terminal damage $\leq 1/2$ FPC terminal width and can not affect the function , we judge accept.<br>13.2 FPC alignment hole damage $\leq 1/2$ alignment area and can not affect the function , we judge accept.  | 2.5<br>2.5                                      |
| 14 | Soldering          | 14.1 No cold solder joints, missing solder connections, oxidation or icicle.<br>14.2 No short circuits in components on PCB or FPC.   | 2.5<br>0.65                                     |

| NO                | Item                      | Criterion  | AQL               |               |                |  |
|-------------------|---------------------------|--|-------------------|---------------|----------------|--|
| 15                | Touch Panel Chipped glass | <p>Symbols:<br/> x: Chip length                      y: Chip width                      z: Chip thickness<br/> k: Seal width                      t: Touch Panel Total thickness    a: LCD side length<br/> L: Electrode pad length</p> <p>15.1 General glass chip:<br/> 15.1.1 Chip on panel surface and crack between panels:</p>  | 2.5               |               |                |  |
|                   |                           | <table border="1" style="width: 100%; text-align: center;"> <tr> <td>z: Chip thickness</td> <td>y: Chip width</td> <td>x: Chip length</td> </tr> </table>  | z: Chip thickness | y: Chip width | x: Chip length |  |
| z: Chip thickness | y: Chip width             | x: Chip length   |                   |               |                |  |

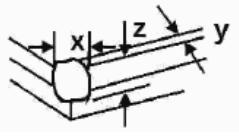
|                   |  |   |  |                   |               |                |            |  |               |  |  |  |
|-------------------|--|---|--|-------------------|---------------|----------------|------------|--|---------------|--|--|--|
|                   |  | $Z \leq t$  | $\leq 1/2 k$ and not over viewing area | $x \leq 1/8a$     |               |                |            |  |               |  |  |  |
|                   |  | <p>⊙ Unit: mm</p> <p>⊙ If there are 2 or more chips, x is the total length of each chip</p> <p>15.1.2 Corner crack:</p>    |  |                   |               |                |            |  |               |  |  |  |
|                   |  | <table border="1"> <tr> <td>z: Chip thickness</td> <td>y: Chip width</td> <td>x: Chip length</td> </tr> <tr> <td><math>z \leq t</math></td> <td><math>\leq 1/2 k</math> and not over viewing area</td> <td><math>x \leq 1/8a</math></td> </tr> </table> |  | z: Chip thickness | y: Chip width | x: Chip length | $z \leq t$ | $\leq 1/2 k$ and not over viewing area | $x \leq 1/8a$ |  |  |  |
| z: Chip thickness | y: Chip width                          | x: Chip length  |  |                   |               |                |            |  |               |  |  |  |
| $z \leq t$        | $\leq 1/2 k$ and not over viewing area | $x \leq 1/8a$   |  |                   |               |                |            |  |               |  |  |  |
|                   |  | <p>⊙ Unit: mm</p> <p>⊙ If there are 2 or more chips, x is the total length of each chip</p>   |  |                   |               |                |            |  |               |  |  |  |

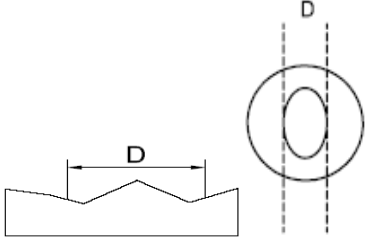
| NO                    | Item  | Criterion   | AQL   |                 |                 |                 |                       |   |                       |   |              |   |     |
|-----------------------|---|---|---|-----------------|-----------------|-----------------|-----------------------|---|-----------------------|---|--------------|---|-----|
| 16                    | Touch Panel(Fish eye、dent and bubble on film) | <table border="1"> <tr> <th>SIZE(mm)</th> <th>Acceptable Q'ty</th> </tr> <tr> <td><math>\Phi \leq 0.2</math></td> <td>Accept no dense</td> </tr> <tr> <td><math>0.2 &lt; \Phi \leq 0.4</math></td> <td>5</td> </tr> <tr> <td><math>0.4 &lt; \Phi \leq 0.5</math></td> <td>2</td> </tr> <tr> <td><math>\Phi &gt; 0.5</math></td> <td>0</td> </tr> </table>  | SIZE(mm)  | Acceptable Q'ty | $\Phi \leq 0.2$ | Accept no dense | $0.2 < \Phi \leq 0.4$ | 5 | $0.4 < \Phi \leq 0.5$ | 2 | $\Phi > 0.5$ | 0 | 2.5 |
| SIZE(mm)              | Acceptable Q'ty                               |   |   |                 |                 |                 |                       |   |                       |   |              |   |     |
| $\Phi \leq 0.2$       | Accept no dense                               |   |   |                 |                 |                 |                       |   |                       |   |              |   |     |
| $0.2 < \Phi \leq 0.4$ | 5   |   |   |                 |                 |                 |                       |   |                       |   |              |   |     |
| $0.4 < \Phi \leq 0.5$ | 2   |   |   |                 |                 |                 |                       |   |                       |   |              |   |     |
| $\Phi > 0.5$          | 0   |   |   |                 |                 |                 |                       |   |                       |   |              |   |     |
| 17                    | Touch Panel Newton ring                       | Newton ring dimension $\leq 1/2$ touch panel area and not affect font and line distortion( $\leq 2.5\%$ ), it is acceptable.  | 2.5   |                 |                 |                 |                       |   |                       |   |              |   |     |
| 18                    | Touch Panel Linearity                         | Less than 2.5% is acceptable.   | 2.5   |                 |                 |                 |                       |   |                       |   |              |   |     |
| 19                    | LCD Ripple                                    | Touch the touch panel , can not see the LCD ripple.<br>Pen: R 1.0mm silicon rubber.<br>Operation Force: 80g   | 2.5   |                 |                 |                 |                       |   |                       |   |              |   |     |
| 20                    | General appearance                            | <p>20.1 Pin type must match type in specification sheet.</p> <p>20.2 LCD pin loose or missing pins.</p> <p>20.3 Product packaging must the same as specified on packaging specification sheet.</p> <p>20.4 Product dimension and structure must conform to product specification sheet.</p>   | <p>0.65</p> <p>0.65</p> <p>0.65</p> <p>0.65</p> |                 |                 |                 |                       |   |                       |   |              |   |     |

## 13. Handling Precaution:

### 13-1 Handling of LCM

- don't give external shock.
- Don't apply excessive force on the surface.
- Liquid in LCD is hazardous substance. Must not lick and swallow. when the liquid is attach to your hand, skin, cloth etc. Wash it out thoroughly and immediately.
- Don't operate it above the absolute maximum rating.
- Don't disassemble the LCM.
- The operators should be grounded whenever he/she comes into contact with the module. Never touch any of the conductive parts such as the LSI pads, the copper leads on the PCB and the interface terminals with any parts of the human body.
- The modules should be kept in antistatic bags or other containers resistant to static for storage.
- The module is coated with a film to protect the display surface. Be care when peeling off this protective film since static electricity may be generated.

### 13-2 Storage

- Store in an ambient temperature of  $25\pm 10^{\circ}\text{C}$ , and in a relative humidity of  $50\pm 10\%\text{RH}$ . Don't expose to sunlight or fluorescent light.
- Storage in a clean environment, free from dust, active gas, and solvent.
- Store in anti-static electricity container.
- Store without any physical load.
- Appearance, 3months;Function,1year;within the validity, failed CTP can be replaced 1 to 1

### 12-3 Soldering

- Use only soldering irons with proper grounding and no leakage.
- Iron: No higher than  $310\pm 10^{\circ}\text{C}$  and less than 3 sec during Hand soldering.
- Rewiring: no more than 2 times.

## 14. Warranty

This product has been manufactured to specifications as a part for use in your company's general Electronic products. It is guaranteed to perform according to delivery specifications. For any other Use apart from general electronic equipment, we will not take responsibility if the product is used in Medical devices, nuclear power control equipment, aerospace equipment, fire and security systems, or any other applications in which there is a direct risk to human life and where extremely high levels of reliability are required. If the product is to be used in any of the above applications, we will need to enter into a separate product liability agreement.

1. We cannot accept responsibility for any defect arise after additional process of the product (including disassembly and reassembly), after product delivery.
2. We cannot accept responsibility for any defect, which may arise after the application of strong external force to the product.
3. We cannot accept responsibility for any defect, which may arise due to the application of static electricity after the product has passed your company's acceptance inspection procedures.
4. We can not accept responsibility for industrial property, which may arise through the use of your product , with exception to those issues relating directly to the structure or method of manufacturing of our product within one year from YEEBO shipment.
5. For Heatseal Product which required to heatseal by customer side, parts must be used within three months after delivery from factory.
6. For TAB Product which required to solder by customer side, parts must be used within three months after delivery from factory.
7. The liability of YB is limited to repair or replacement on the terms set forth below. YB will not be responsible for any subsequent or consequential events or injury or damage to any personnel or user including third party personnel and/or user. Unless otherwise agreed in writing between YB and the customer, YB will only replace or repair any of its LCD which is found defective electrically or visually when inspected in accordance with YB GENERAL LCD INSPECTION STANDARD.

## 15. Guarantee:

Our products meet requirements of the environment.

YEEBO ROHS requirement is based on European Union Directive 2011/65/EU (ROHS) Requirements and Update.

## ANSPRECHPARTNER



Für Fragen stehe ich Ihnen gerne persönlich zur Verfügung,

+43 (676) 466 466 0

od. per E-Mail

[robert.glaser@glaser-eng.com](mailto:robert.glaser@glaser-eng.com) .

Anfragen nehmen wir gerne unter der E-Mail-Adresse

[info@glaser-eng.com](mailto:info@glaser-eng.com)

entgegen.



Y o u r t h o u g h t i s o u r p a s s i o n !

[info@glaser-eng.com](mailto:info@glaser-eng.com)

[www.glaser-eng.com](http://www.glaser-eng.com)