

Model
500
cfm

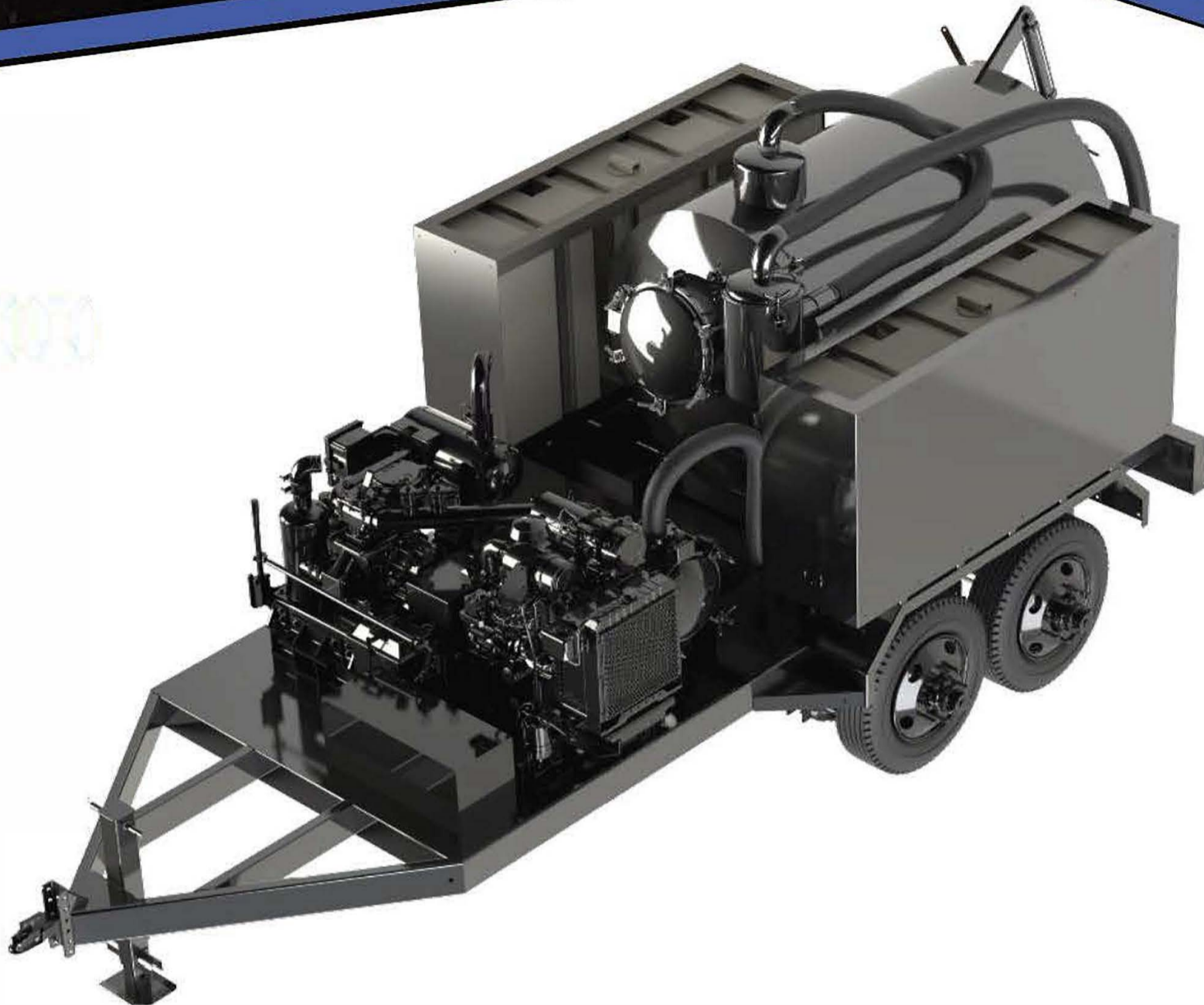

500 CFM VACUUM EXCAVATOR

DIMENSIONS AND WEIGHTS

Length: 21' 6" **Width:** 98.5"
Height: 7' 6" **G.V.W.R.:** 14,000 lbs.
Empty Weight: 7,700 lbs.
Payload: Approximately 10,700 lbs.

UNIT PERFORMANCE

High Pressure Wash Pump:

Flow Rate: 4 GPM
Pressure: 4000 PSI Adjustable

Vacuum:

Filters: .5 micron **Hose Length:** 30'
Hose Diameter: 3" **Flow Rate:** 431 CFM
Blower Type: Tri-Lobe **Pressure:** 24 inHg

OPTIONS

- Semi-Soft Custom Paint Color
- Hot Water Heater • Manual Boom
- Valve Exerciser • Jet Wash Downs

STANDARD FEATURES

Engine: 36.9 hp water cooled diesel
Fuel Tank Capacity: 17 gal
Running Gear: Two 8,000 lb. single wheel axle with oil bath hubs 4" drop
Brakes: 12 ¼" x 3-3/8" electric with self-charging break-away system
Landing Gear: 12,000 lb. static drop leg jack
Wheels: 16" 8-hole Steel
Tires: 235/80R 16" 14-Ply
Lights: Sealed beam with waterproof wiring in nylon tubing
Water Tanks: 400 gallon total **Number of Tanks:** 2
Tank Lift: Hydraulic scissor lift for full dump at 70° tilt
Spoil Tank: 800 gallons
Door Type: Hydraulic with 8 manual wing nuts
Wash: Internal wash out system
Thickness: ¼" allowing for 15 PSI to pressure off and full vacuum
Control Panel: Curbside **Gauges:** Analog