

2021
Collection

neil david



unusual

usual

We design products where the idea is, and stays, the centerpiece of the design process, from beginning to end. We honor the simplicity of geometric forms in many of our products.

Construction strategies are also often creatively integrated to be a part of the design solution.

Wij ontwerpen producten waarbij het idee in het ontwerp proces centraal staat. Geometrische vormen vind je in veel van onze producten terug. Samen met een constructie die is geïntegreerd in het ontwerp. Dit resulteert al dan niet in een onderdeel van het totale ontwerp.

INDEX

F2 SERIE	1
BARFLY STOOL	7
BT4 SMALL TABLE	11
CHEERS SERIE	15
F1 SERIE	21
WABI BOOKCASE	27
ANGLE SERIE	31
TWIG LOUNGE CHAIR	35
LAP LOUNGE CHAIR	39
X LOUNGE CHAIR	43
CONTRA SERIE	49
COLOURS	55
COLLECTION	59
CONTACT	61

INHOUD

F2 SERIE	1
BARFLY KRUK	7
BT4 BIJZETTAFEL	11
CHEERS SERIE	15
F1 SERIE	21
WABI BOEKENKAST	27
ANGLE SERIE	31
TWIG FAUTEUIL	35
LAP FAUTEUIL	39
X FAUTEUIL	43
CONTRA SERIE	49
KLEUREN	55
COLLECTIE	59
CONTACT	61



F2

Serie







F2

Serie

2014

Neil David Coppens

^{EN} The F2 seat is based on a solid ash wood cross foot which continues up to the armrest. The back and seat are upholstered in a single cover.

^{NED} De F2 staat op een massief esenhouten kruisvoet welke doorloopt tot aan de armlegger. De rug en zitting zijn uit één hoes gestoffeerd.

TECHNICAL SPECIFICATION

Frame: Solid European ash wood

Certificates: FSC and PEFC (making use of)

Finish: Water based stain + water based matte lacquer

Certificates/ Test Report: DIN EN 12720 (group 1B)

DIN 53160

Cold liquids (ISO 4211

German version EN12720:2009)

Seat: Birch plywood construction + foam and fabric

Certificates: Birch plywood FSC and PEFC (making use of)

Foam and fabric BS 5852 part 2 (Crib5) or

CAL 117-2013

DIMENSIONS CM / INCH

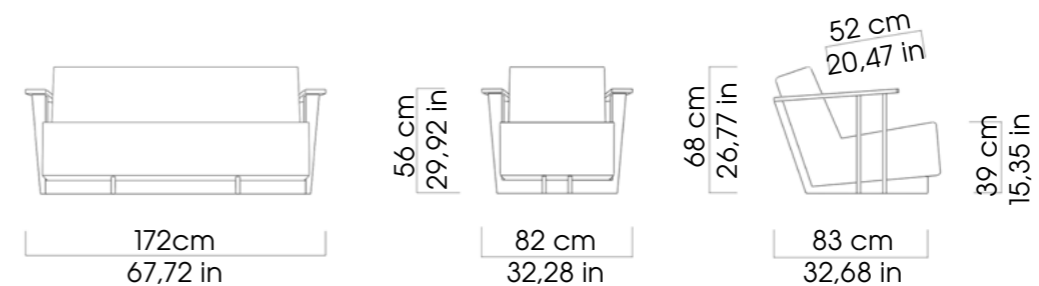

BARFLY

Stool





BARFLY

Stool

2015

Neil David Coppens

EN The Barfly stool is constructed of solid ash wood, with a play on the contrast between the round legs and square seat.

NED De Barfly kruk is gemaakt van massief essenhout, waarbij het onderstel is samengesteld uit rondhout met daarop een contrasterende rechte lijnige zitting met lende steun.

TECHNICAL SPECIFICATION

Frame: Solid European ash wood

Certificates: FSC and PEFC (making use of)

Finish: Water based stain + water based matte lacquer

Certificates/ Test Report: DIN EN 12720 (group 1B)

DIN 53160

Cold liquids (ISO 4211 German version

EN12720:2009)

DIMENSIONS CM / INCH

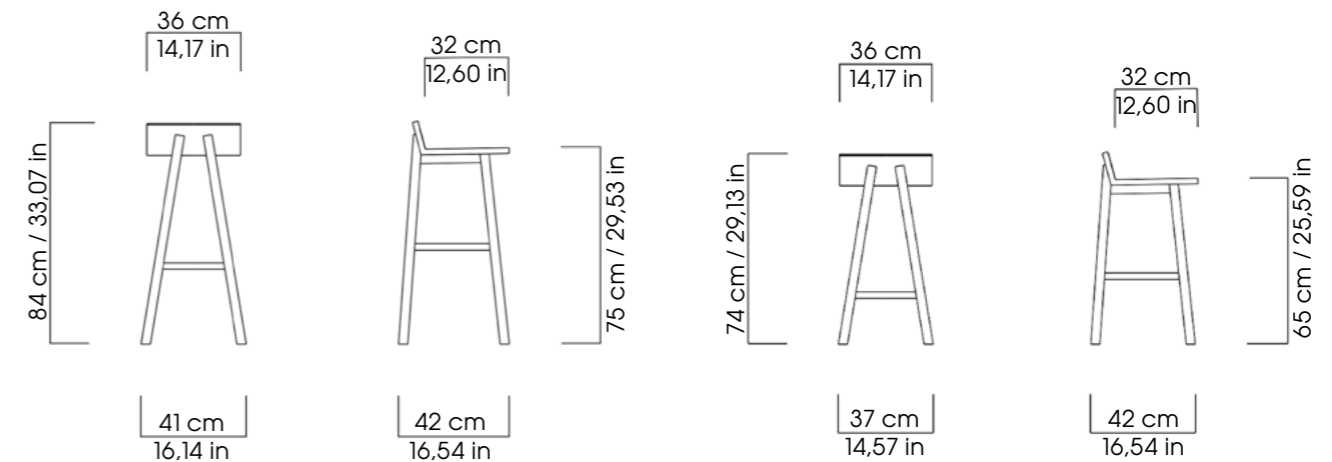



BT4
Bijzettafel



BT4

Small Table

2014

Neil David Coppens

^{EN} In and of itself, an aluminum sheet is very flexible. Angled bending transforms a flexible aluminum sheet into a rigid construction. The triangular feet also function as storage shelves. Useful for bedsides, living rooms, waiting and lounge area. The finish is a powder coat matte fine texture.

^{NED} De BT4 is gemaakt van een dunne plaat aluminium. Door er driehoeksvormen in te vouwen en deze met elkaar te verbinden ontstaat er een stijve constructie. Een handige ruimte voor het opbergen van tijdschriften, kranten etc. De BT4 is toe te passen naast bed, bank, wacht,-en lounge ruimte. Afwerking is matte fine texture poedercoat.

TECHNICAL SPECIFICATION

Material: Aluminum sheet

Finish: Powder coat matte fine texture

Standard: EN 12206, EN13438, EN13051 + A1 : 2013

DIMENSIONS CM / INCH

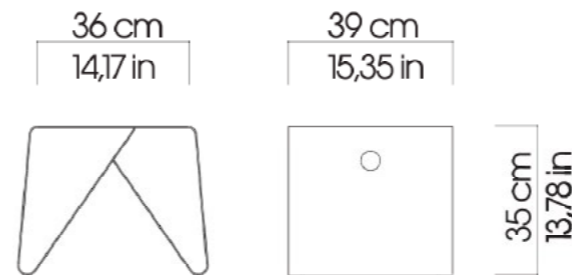



CHEERS

Serie







CHEERS

Serie

2018

Neil David Coppens

EN Born from the desire to design a café stool or chair with a light appearance and strength to withstand intensive use. The steel tube frame references the back and armrests of a classical café stool or chair. The frame is finished with matte powder coat fine texture.

NED Een licht geconstrueerde café kruk of stoel was het idee. Het stalen frame is hiervan de basis. De vorm van de rug geeft de Cheers de identiteit van een café kruk of stoel. Het frame heeft een matte fine texture poedercoat.

TECHNICAL SPECIFICATION

Seat and back: Solid European ash wood
 Certificates: FSC and PEFC (making use of)

Finish: Water based stain + water based matte lacquer
 Certificates/ Test Report: DIN EN 12720 (group 1B)
 DIN 53160
 Cold liquids (ISO 4211 German version
 EN12720:2009)

Upholstered seat: Beech plywood construction + foam and fabric
 Certificates: Beech plywood FSC and PEFC (making use of)
 Foam and fabric BS 5852 part 2 (Crib5) or CAL 117-2013

DIMENSIONS CM / INCH

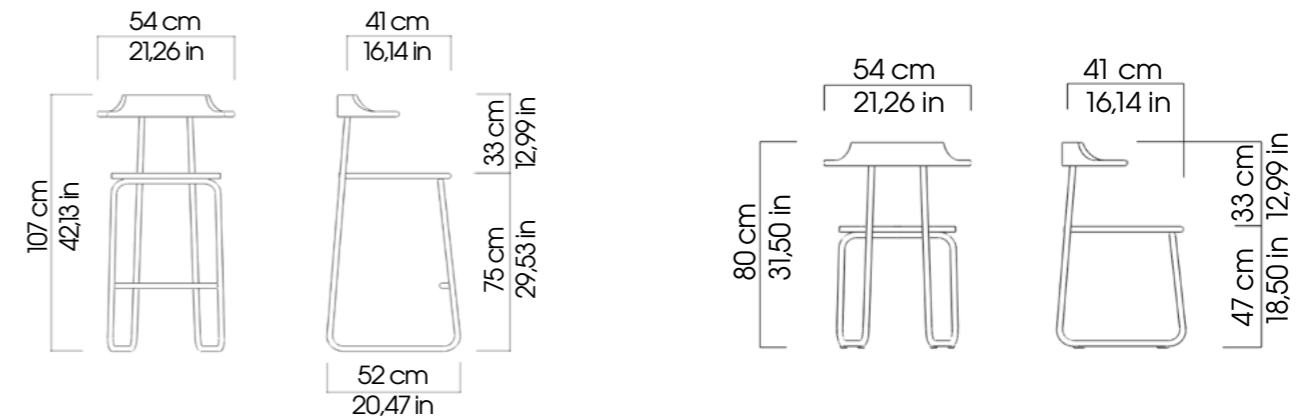



F1
Serie





F1

Serie

2014

Neil David Coppens

^{EN} The back legs of this chair are folded into a hairpin shape to create a light but strong frame. This single line from the seat to the back provides strength with an elegant continuous line.

^{NED} De uitdaging was om een zeer rank frame te ontwerpen wat aan alle eisen voldoet. De sterkte is bereikt door een haarspeld in de achterpoot te creëren. Het frame loopt in één lijn om de stoel of bank heen.

TECHNICAL SPECIFICATION

Frame: Solid steel

Finish: Powder coat matte fine texture

Seat and back: Beech plywood construction + foam and fabric

Certificates: Beech plywood FSC and PEFC (making use of)

Foam and fabric BS 5852 part 2 (Crib5) or CAL 117-2013

DIMENSIONS CM / INCH

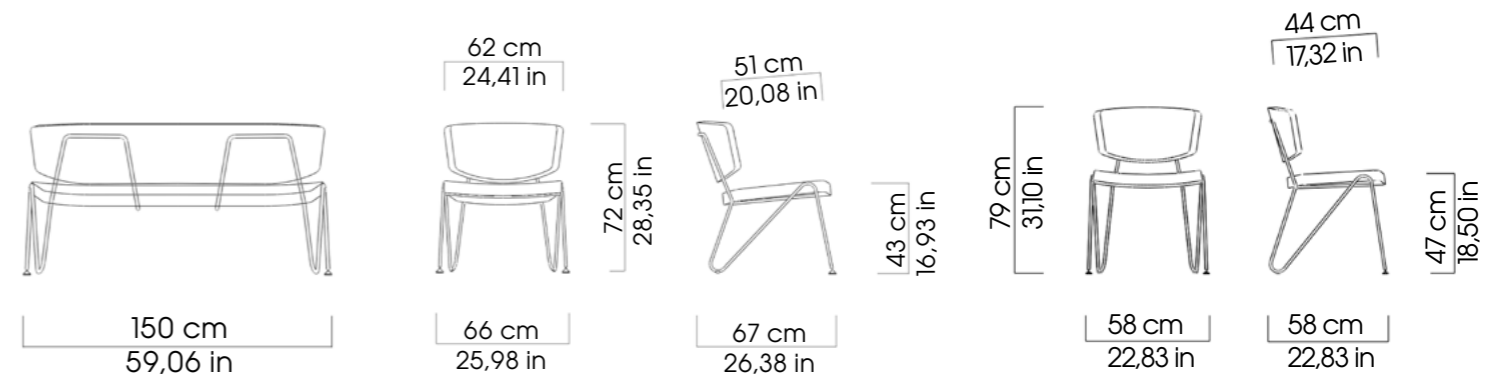



WABI
Bookcase

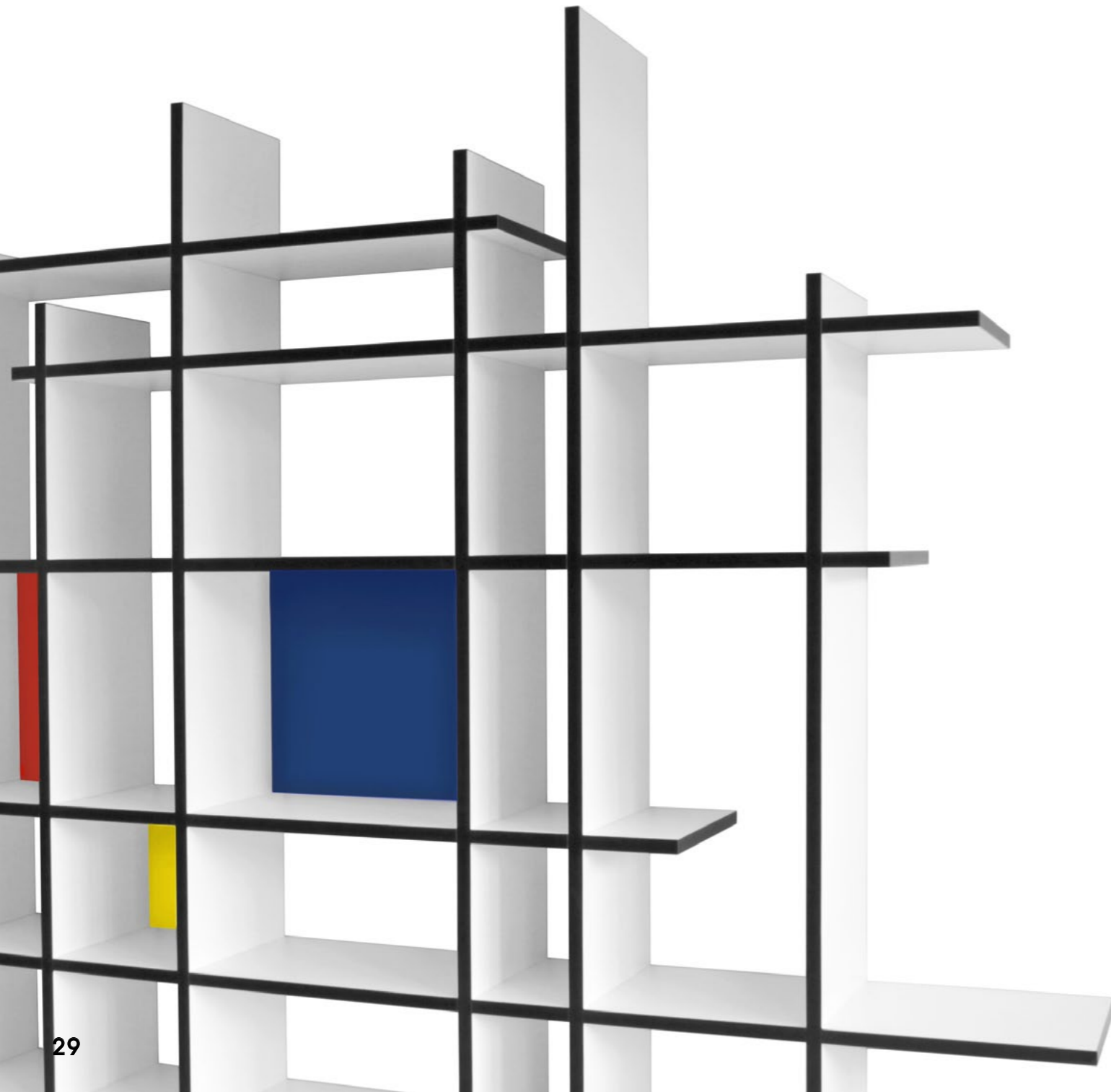

WABI

Bookcase

2014

Neil David Coppens

EN The Wabi is an asymmetrical bookcase or room divider. It begins in a structured grid that unravels incrementally to finish with an 'open' end. The white shelves with black edge serve to frame anything put within the individual squares. With simplicity and form in mind, no screws or glue are needed. You can change the colored squares to white.

NED De Wabi is een asymmetrische boekenkast of ruimtescheider. Het raster begint linksonder met vier vakken van gelijke afmeting en rafelt uit naar een willekeur aan vakafmetingen en uiteinden van de kast. Door de witte planken zwarte randen te geven wordt het lijnenspel extra geaccentueerd. De constructie is éénvoudig, de verticalen en horizontalen delen worden in elkaar geschoven. De gekleurde rugdelen zijn aan de achterkant wit en kunnen gedraaid worden.

TECHNICAL SPECIFICATION

Sheets: MDF is FSC and PEFC (making use of)

Finish: HPL Cristal White + ABS black sides + Colored rectangles
HPL Blue, red and yellow with a white HPL back.

DIMENSIONS CM / INCH

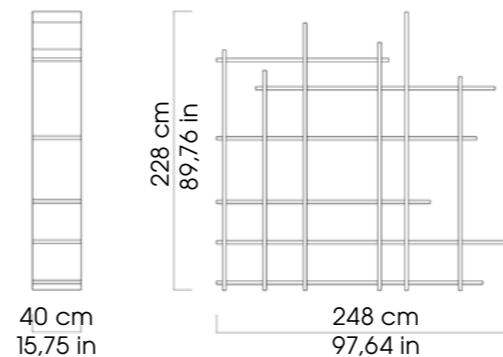





ANGLE

Serie

2017

Neil David Coppens

^{EN} The steel frame of this chair consists of only 90 degree angles. In contrast, oblique placement of the foam seating elements provide a visual contrast as well as improved seating comfort.

^{NED} Het stalen kokerframe is samengesteld uit alleen maar 90 graden hoeken. Voor de rug en de zitting zijn dezelfde rechthoekige vormen gekozen, maar door deze schuin in het frame te plaatsen ontstaat er een valling en wordt het uiteindelijk zitcomfort gecreëerd.

TECHNICAL SPECIFICATION

Frame: Steel

Finish: Powder coat matte fine texture

Seat and back: Birch plywood construction + foam and fabric

Certificates: Birch plywood FSC and PEFC (making use of)

Foam and fabric BS 5852 part 2 (Crib5) or CAL 117-2013

DIMENSIONS CM / INCH

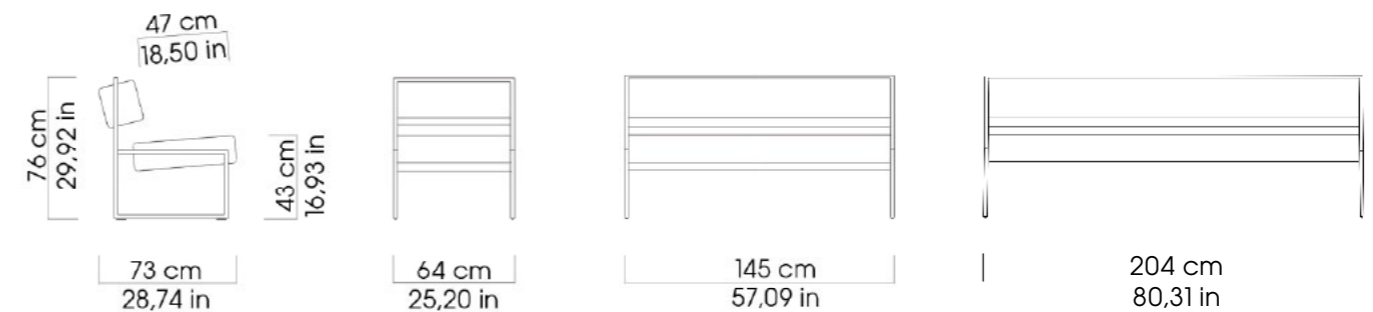

TWIG

Armchair





TWIG

Armchair

2018

Neil David Coppens

EN This chair is named after the twig that inspired the design of it's legs. These are formed from solid ash wood. The legs grow to serve as the arm rest. The Twig provides a compact armchair with great comfort.

NED De naam Twig heeft deze fauteuil te danken aan de vorm van de poten en zijn gemaakt van massief esenhout. De voorpoot heeft tevens de functie van armlegger. De Twig is een compacte fauteuil met een hoog zitcomfort.

TECHNICAL SPECIFICATION

Frame: Solid European ash wood
Certificates: FSC and PEFC (making use of)

Finish: Water based stain + water based matte lacquer
Certificates/ Test Report: DIN EN 12720 (group 1B)
DIN 53160
Cold liquids (ISO 4211 German version
EN12720:2009)

Seat: Beech plywood construction + foam and fabric
Certificates: Beech plywood FSC and PEFC (making use of)
Foam and fabric BS 5852 part 2 (Crib5) or CAL 117-2013

DIMENSIONS CM / INCH

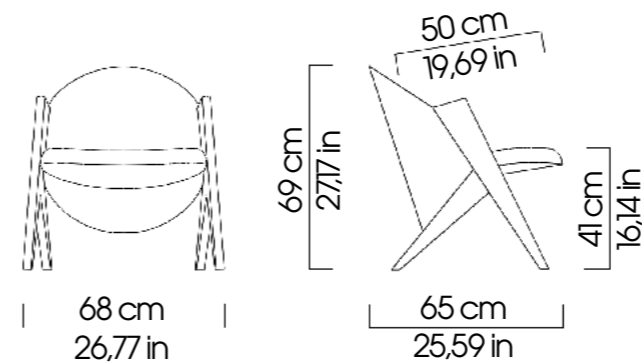

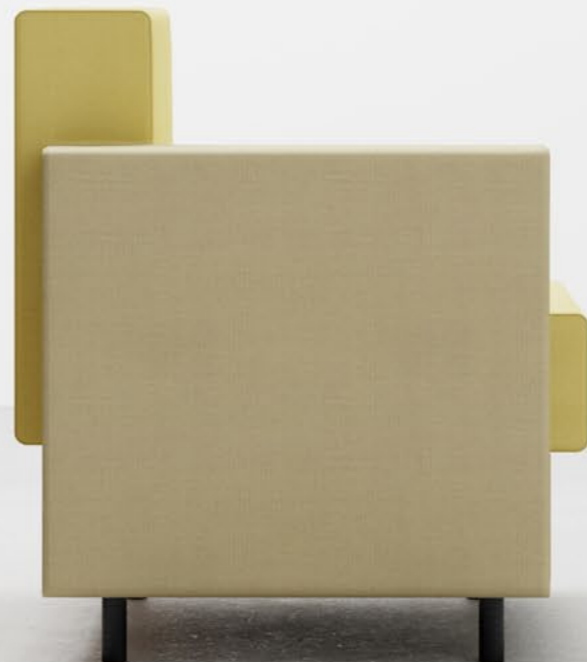



LAP

Lounge Chair

2019

Neil David Coppens

EN The Lap chair is constructed from the simplicity of two L-shaped elements stacked on each other. With a minimal 90 degree move, they combine to form a cubical seating corner.

NED The Lap fauteuil is opgebouwd uit twee L-vormen die op elkaar gestapeld zijn. Samen vormen ze een kubistisch zit element.

TECHNICAL SPECIFICATION

Seat and back: Birch plywood construction + foam and fabric

Certificates: Birch plywood FSC and PEFC (making use of)

Foam and fabric BS 5852 part 2 (Crib5) or CAL 117-2013

DIMENSIONS CM / INCH

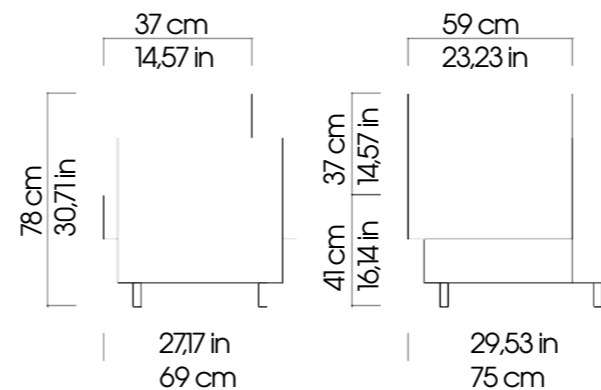



X

Lounge Chair

X
Lounge Chair





X

Lounge Chair

2020

Neil David Coppens

^{EN} The chair characterized by the cross shaped back of the frame.

^{NED} De stoel kenmerkt zich door de kruisvormige achterkant van het frame.

TECHNICAL SPECIFICATION

Seat and back: Beech plywood construction + foam and fabric
Certificates: Beech plywood FSC and PEFC (making use of)
Foam and fabric BS 5852 part 2 (Crib5) or CAL 117-2013

DIMENSIONS CM / INCH

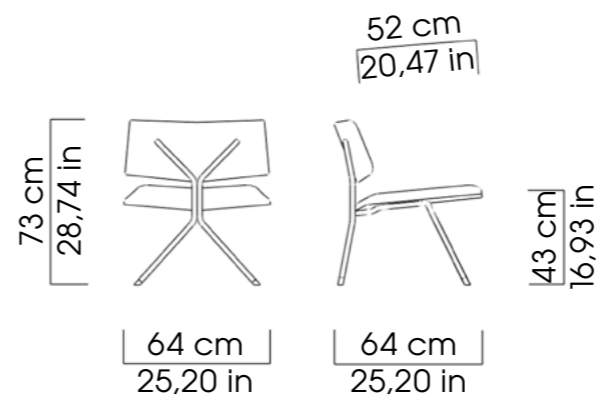

Contra

Serie





Contra

Serie



Contra

Serie

2021

Neil David Coppens

^{EN} By placing the elements of the armrests and seat in an opposite angle, a floating effect is created. The angles also serve the seating comfort.

^{NED} Door de elementen van de armleggers en zitelement contra van elkaar te plaatsen wordt er een zwevend effect gecreëerd. Tevens zorgt de contra positie van de elementen voor een goed zitcomfort.

TECHNICAL SPECIFICATION

Seat and back: Birch plywood construction + foam and fabric

Certificates: Birch plywood FSC and PEFC (making use of)

Foam and fabric BS 5852 part 2 (Crib5) or CAL 117-2013

DIMENSIONS CM / INCH

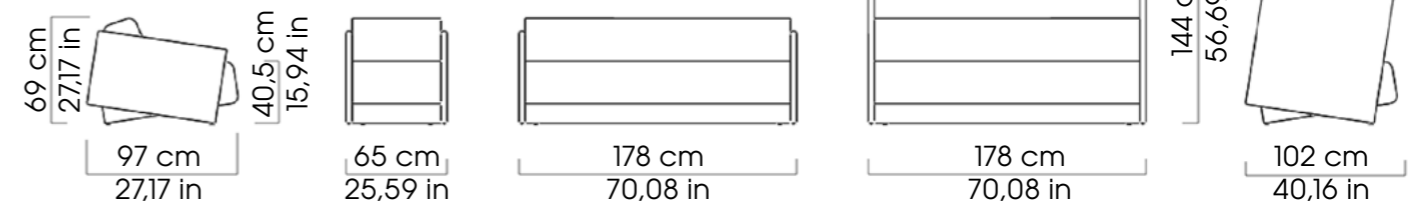

WOOD FINISH STAINS

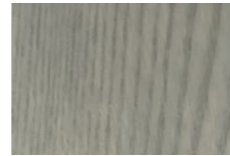

light grey
licht grijs



7034
yellow grey
geel grijs

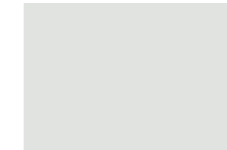

7035
light grey
licht grijs

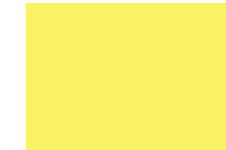

1016
yellow
geel

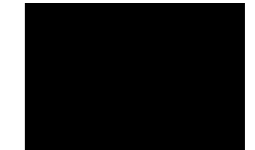

9011
black
zwart



natural
blank

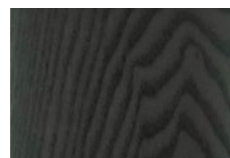

black
zwart



white
wit



dark brown
donker bruin



5002
ultra blue
ultra blauw



5024
light blue
licht blauw



5003
dark blue
dark blauw



9010
white
wit

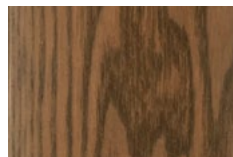

light brown
licht bruin



blue
blauw



orange
oranje



red
rood

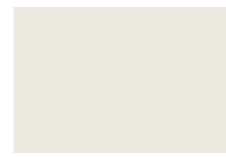

1013
oyster white
gebroken wit



6004
blue green
blauw groen



3004
purple red
paars rood



3020
red
rood

The water based stain options accentuate the structure of the ash wood, while a water based matte lacquer finish allows the texture of the grain to show through a denser colour coverage.



2002
orange
oranje

WOOD FINISH MATTE COLOR LACQUERS

The matte finish does not influence the true colour of the lacquer.

POWDER COATS MATTE FINE STRUCTURE



9005
black
zwart

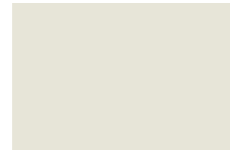

1013
oyster white
gebroken wit



3020
red
rood



3004
dark red
donker rood



9010
white
wit



8014
dark brown
donker bruin

POWDER COATS METALLIC

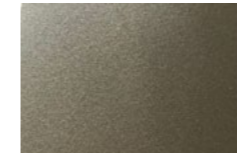

006
metallic bronze
metallic brons

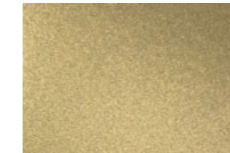

007
metallic gold
metallic goud

Please be advised that the colours on these pages are printed and therefore may differ slightly from the original.



F1
LOUNGE
CHAIR



F1
SOFA
for 2



F1
DINING
CHAIR



CHEERS
STOOL



CHEERS
UPHOL
STOOL

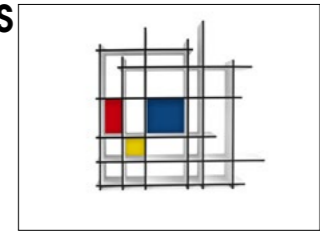

WABI
BOOK-
CASE



F2
ARM
CHAIR



F2
SOFA
FOR 2



LAP
LOUNGE
CHAIR



CHEERS
DINING
CHAIR



CHEERS
UPHOL
DINING
CHAIR



ANGLE
LOUNGE
CHAIR



ANGLE
SOFA
FOR 2



ANGLE
SOFA
FOR 3



TWIG
LOUNGE
CHAIR



BT4
SMALL
TABLE



CONTRA
LOUNGE
CHAIR
new



CONTRA
SOFA
LOW
new



CONTRA
SOFA
HIGH
new



BARFLY
STOOL



X
LOUNGE
CHAIR

More information?

neildavid

Studio HQ
Weesperstraat 96H
1112 AP Diemen
Metropolitan Area of Amsterdam
Netherlands
info@neildavid.com
+31 (0)20 4471507

Our website
neildavid.com

Your agent for the USA
Newton Brown Urban Design
106 W32nd. Street
New York, NY 10001
Tel +1 347 879 4869
Fax + 1 347 402 2555
info@newtonbrownusa.com
www.newtonbrownusa.com
#nbudusa @nbudusa

Neil David has the right to change both the design, the material and/or dimensions from this publication with no obligation.

Neil David heeft het recht om veranderingen aan te brengen in zowel ontwerp als materiaal en afmetingen in tegenstelling tot wat er gepubliceerd is zonder waarschuwing.

© 2020 Neil David. All Rights Reserved.

**Thank
you.**