

COLLECTION  
2020

neil david

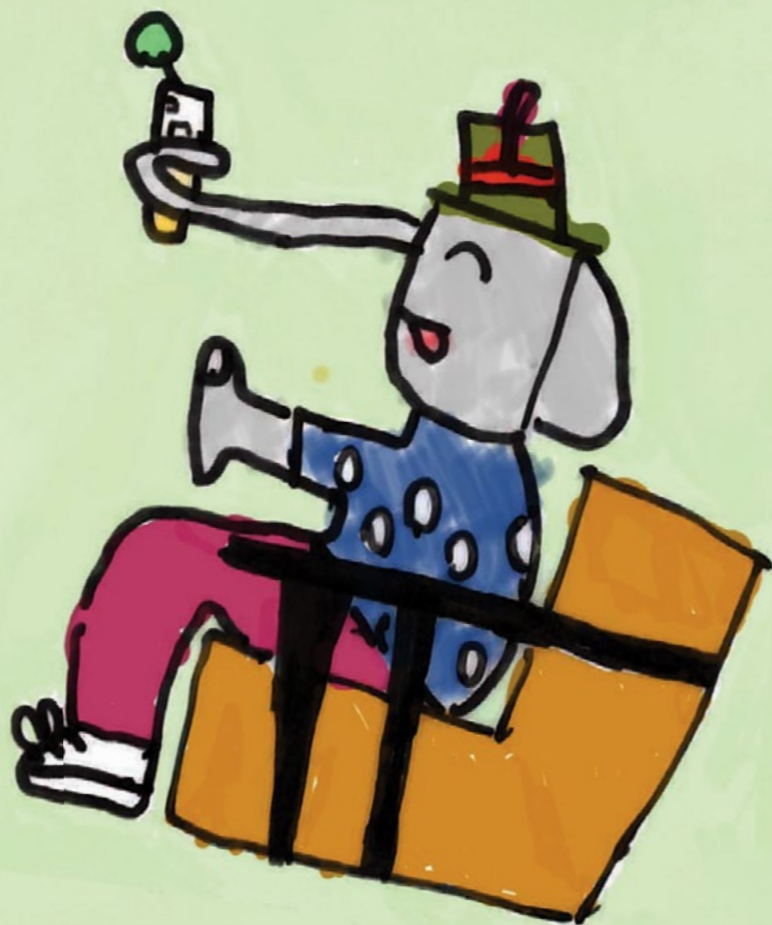

unusual

usual

We design products where the idea is, and stays, the centerpiece of the design process, from beginning to end. We honor the simplicity of geometric forms in many of our products.

Construction strategies are also often creatively integrated to be a part of the design solution.

Wij ontwerpen producten waarbij het idee in het ontwerp proces centraal staat. Geometrische vormen vind je in veel van onze producten terug. Samen met een constructie die is geïntegreerd in het ontwerp. Dit resulteert al dan niet in een onderdeel van het totale ontwerp.

## INDEX

F2 SERIE	1
BARFLY STOOL	9
BT4 SMALL TABLE	13
CHEERS SERIE	17
F1 SERIE	23
WABI BOOKCASE	29
ANGLE SERIE	33
TWIG LOUNGE CHAIR	39
LAP LOUNGE CHAIR	43
X LOUNGE CHAIR	47
COLOURS	51
COLLECTION	55
CONTACT	57

## INHOUD

F2 SERIE	1
BARFLY KRUK	9
BT4 BIJZETTAFEL	13
CHEERS SERIE	17
F1 SERIE	23
WABI BOEKENKAST	29
ANGLE SERIE	33
TWIG FAUTEUIL	39
LAP FAUTEUIL	43
X FAUTEUIL	47
KLEUREN	51
COLLECTIE	55
CONTACT	57



**F2**  
Serie







# F2

Serie

2014

Neil David Coppens

<sup>EN</sup> The F2 seat is based on a solid ash wood cross foot which continues up to the armrest. The back and seat are upholstered in a single cover.

<sup>NED</sup> De F2 staat op een massief essenhouten kruisvoet welke doorloopt tot aan de armlegger. De rug en zitting zijn uit één hoes gestoffeerd.

## TECHNICAL SPECIFICATION

Frame: Solid European ash wood

Certificates: FSC and PEFC (making use of)

Finish: Water based stain + water based matte lacquer

Certificates/ Test Report: DIN EN 12720 (group 1B)

DIN 53160

Cold liquids (ISO 4211

German version EN12720:2009)

Seat: Birch plywood construction + foam and fabric

Certificates: Birch plywood FSC and PEFC (making use of)

Foam and fabric BS 5852 part 2 (Crib5) or

CAL 117-2013

## DIMENSIONS CM / INCH

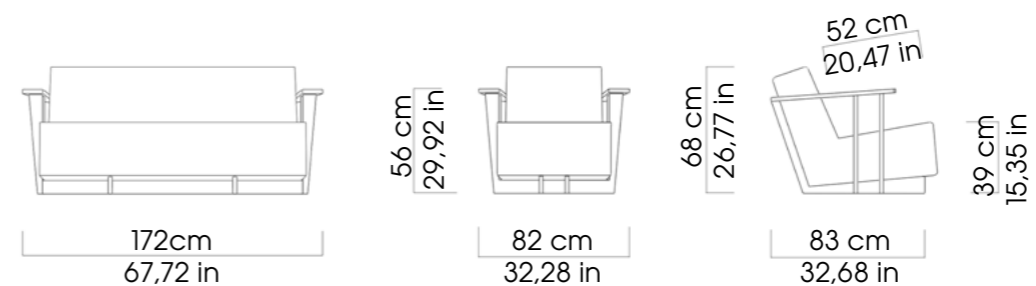



# BARFLY

Stool





# BARFLY

Stool

2015

Neil David Coppens

EN The Barfly stool is constructed of solid ash wood, with a play on the contrast between the round legs and square seat.

NED De Barfly kruk is gemaakt van massief essenhout, waarbij het onderstel is samengesteld uit rondhout met daarop een contrasterende rechte zitting met lende steun.

## TECHNICAL SPECIFICATION

Frame: Solid European ash wood

Certificates: FSC and PEFC (making use of)

Finish: Water based stain + water based matte lacquer

Certificates/ Test Report: DIN EN 12720 (group 1B)

DIN 53160

Cold liquids (ISO 4211 German version  
EN12720:2009)

## DIMENSIONS CM / INCH

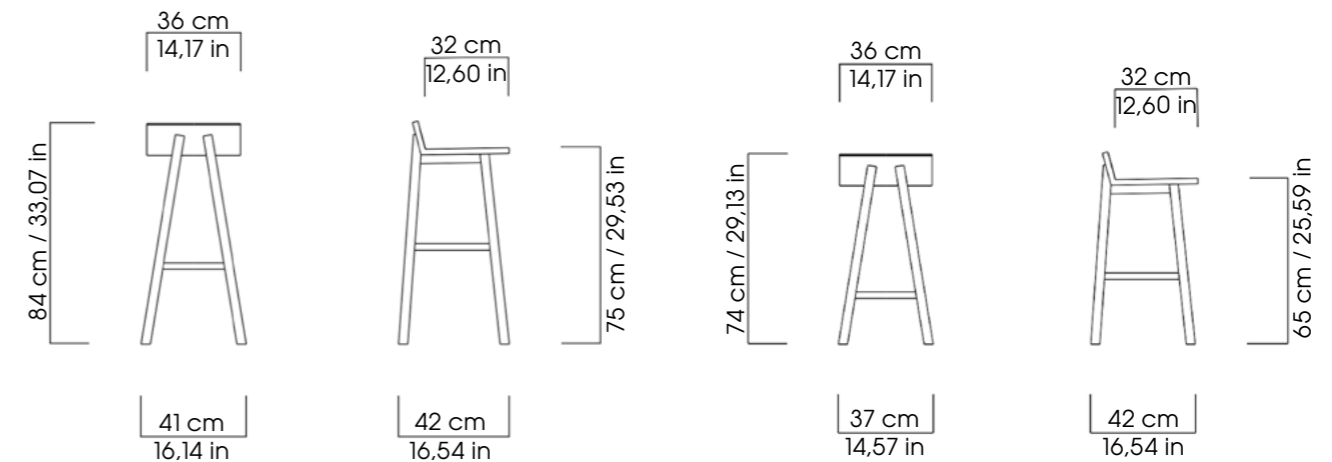



**BT4**  
Bijzettafel



# BT4

Small Table

2014

Neil David Coppens

<sup>EN</sup> In and of itself, an aluminum sheet is very flexible. Angled bending transforms a flexible aluminum sheet into a rigid construction. The triangular feet also function as storage shelves. Useful for bedsides, living rooms, waiting and lounge area. The finish is a matte powder coat.

<sup>NED</sup> De BT4 is gemaakt van een dunne plaat aluminium. Door er driehoeksvormen in te vouwen en deze met elkaar te verbinden ontstaat er een stijve constructie. Een handige ruimte voor het opbergen van tijdschriften, kranten etc. De BT4 is toe te passen naast bed, bank, wacht en lounge ruimte. Afwerking is mat poedercoat.

#### TECHNICAL SPECIFICATION

Material: Aluminum sheet

Finish: Powder coat matte fine texture

Standard: EN 12206, EN13438, EN13051 + A1 : 2013

DIMENSIONS CM / INCH

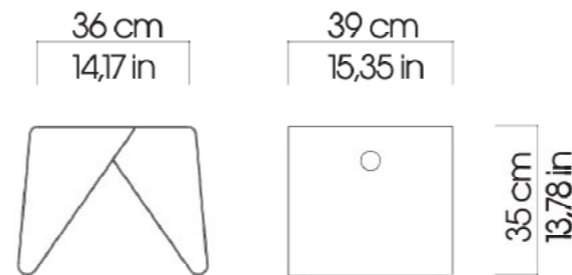

# CHEERS

Serie







# CHEERS

Serie

2018

Neil David Coppens

EN Born from the desire to design a café stool with a light appearance and strength to withstand intensive use. The steel tube frame references the back and armrests of a classical café stool. The frame is finished with matte powder coat.

NED Een licht geconstrueerde café kruk was het idee. Het stalen frame is hiervan de basis. De vorm van de rug geeft de Cheers de identiteit van een café kruk. Het frame heeft een mat structuur poedercoat.

## TECHNICAL SPECIFICATION

Seat and back: Solid European ash wood  
 Certificates: FSC and PEFC (making use of)

Finish: Water based stain + water based matte lacquer  
 Certificates/ Test Report: DIN EN 12720 (group 1B)  
 DIN 53160  
 Cold liquids (ISO 4211 German version  
 EN12720:2009)

Upholstered seat: Beech plywood construction + foam and fabric  
 Certificates: Beech plywood FSC and PEFC (making use of)  
 Foam and fabric BS 5852 part 2 (Crib5) or CAL 117-2013

## DIMENSIONS CM / INCH

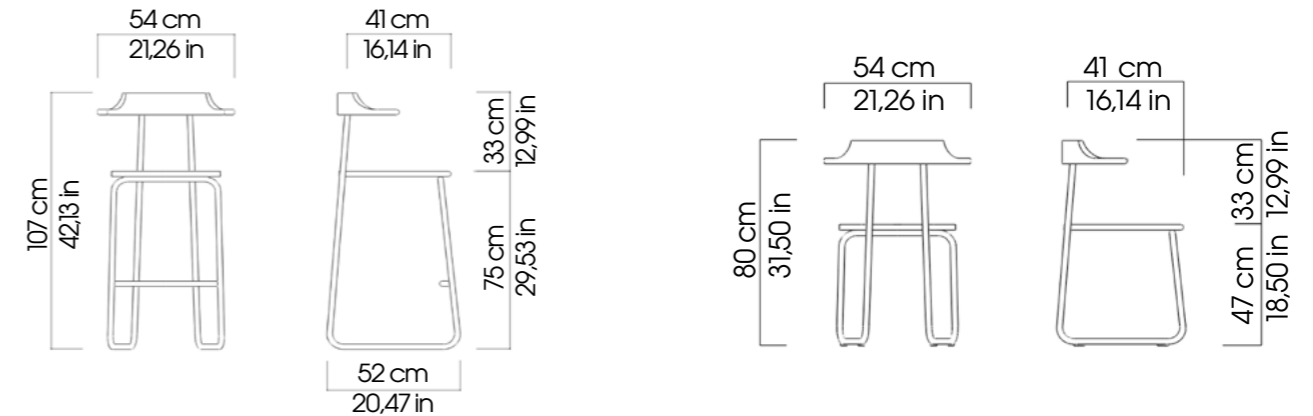







# F1

Serie

2014

Neil David Coppens

<sup>EN</sup> The back legs of this chair are folded into a hairpin shape to create a light but strong frame. This single line from the seat to the back provides strength with an elegant continuous line.

<sup>NED</sup> De uitdaging was om een zeer rank frame te ontwerpen wat aan alle eisen voldoet. De sterkte is bereikt door een haarspeld in de achterpoot te creëren.

## TECHNICAL SPECIFICATION

Frame: Solid steel

Finish: Powder coat matte fine texture

Seat and back: Beech plywood construction + foam and fabric

Certificates: Beech plywood FSC and PEFC (making use of)

Foam and fabric BS 5852 part 2 (Crib5) or CAL 117-2013

## DIMENSIONS CM / INCH

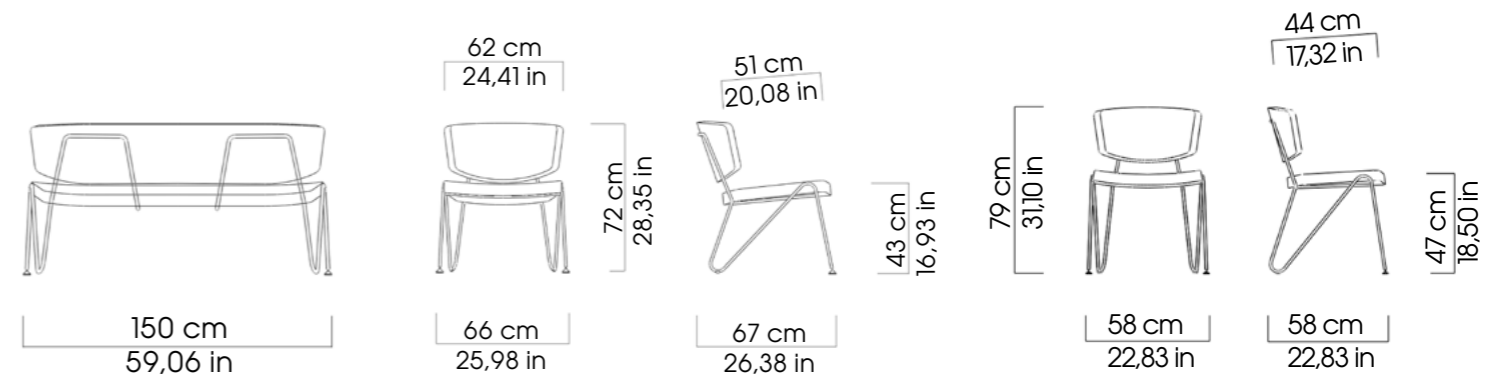



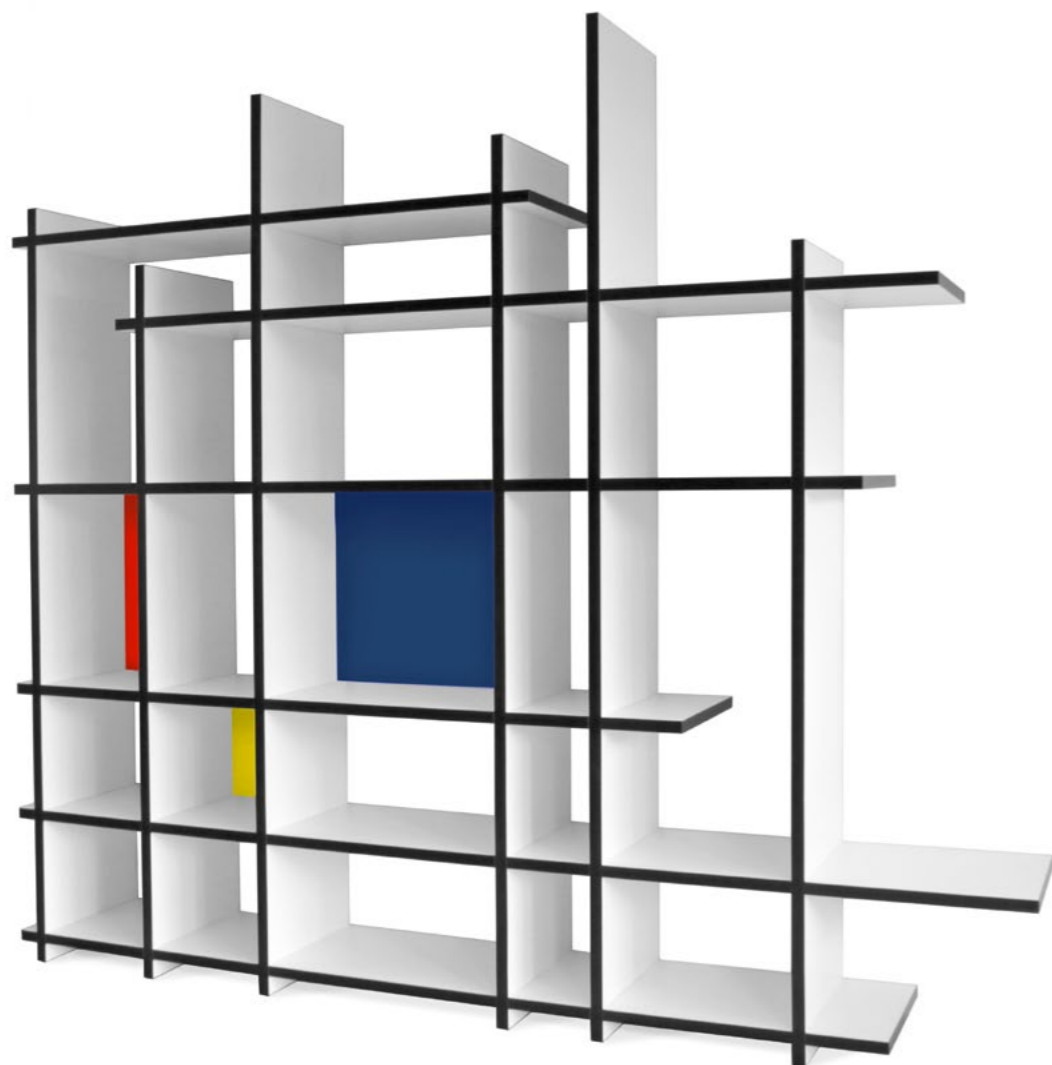

# WABI

Bookcase

2014

Neil David Coppens

EN The Wabi is an asymmetrical bookcase or room divider. It begins in a structured grid that unravels incrementally to finish with an 'open' end. The white shelves with black edge serve to frame anything put within the individual squares. With simplicity and form in mind, no screws or glue are needed. You can change the colored squares to white.

NED De Wabi een asymmetrische boekenkast en ruimtescheider. Het raster begint linksonder met vier vakken van gelijke afmeting en rafelt uit naar een willekeur aan vakafmetingen en uiteinden van de kast. Door de witte planken zwarte randen te geven wordt het lijnenspel extra geaccentueerd. De constructie is éénvoudig, de verticalen en horizontalen delen worden in elkaar geschoven. De gekleurde rugdelen zijn aan de achterkant wit en kunnen gedraaid worden.

## TECHNICAL SPECIFICATION

Sheets: MDF is FSC and PEFC (making use of)

Finish: HPL Cristal White + ABS black sides + Colored rectangles  
HPL Blue, red and yellow with a white HPL back.

## DIMENSIONS CM / INCH

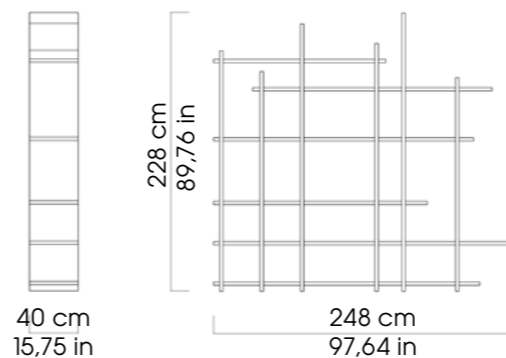







# ANGLE

Serie

2017

Neil David Coppens

<sup>EN</sup> The steel frame of this chair consists of only 90 degree angles. In contrast, oblique placement of the foam seating elements provide a visual contrast as well as improved seating comfort.

<sup>NED</sup> Het stalen kokerframe is samengesteld uit alleen maar 90 graden hoeken. Voor de rug en de zitting zijn dezelfde rechthoekige vormen gekozen, maar door deze schuin in het frame te plaatsen ontstaat er een valling en wordt het uiteindelijk zitcomfort gecreëerd.

## TECHNICAL SPECIFICATION

Frame: Steel

Finish: Powder coat matte fine texture

Seat and back: Birch plywood construction + foam and fabric

Certificates: Birch plywood FSC and PEFC (making use of)

Foam and fabric BS 5852 part 2 (Crib5) or CAL 117-2013

## DIMENSIONS CM / INCH

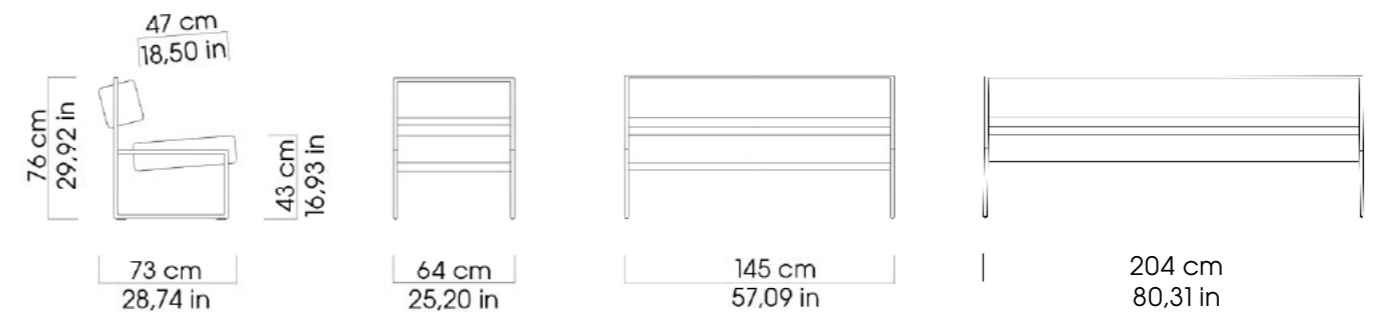

**TWIG**  
Armchair







# TWIG

Armchair

2018

Neil David Coppens

EN This chair is named after the twig that inspired the design of its legs. These are formed from solid ash wood. The legs grow to serve as the arm rest. The Twig provides a compact arm chair with great comfort.

NED De naam Twig heeft deze fauteuil te danken aan de vorm van de poten. Deze zijn gemaakt van massief esenhout. De voorpoot het tevens de functie van armlegger. De Twig is een compacte fauteuil met een hoog zitcomfort.

## TECHNICAL SPECIFICATION

Frame: Solid European ash wood  
Certificates: FSC and PEFC (making use of)

Finish: Water based stain + water based matte lacquer  
Certificates/ Test Report: DIN EN 12720 (group 1B)  
DIN 53160  
Cold liquids (ISO 4211 German version  
EN12720:2009)

Seat: Beech plywood construction + foam and fabric  
Certificates: Beech plywood FSC and PEFC (making use of)  
Foam and fabric BS 5852 part 2 (Crib5) or CAL 117-2013

## DIMENSIONS CM / INCH

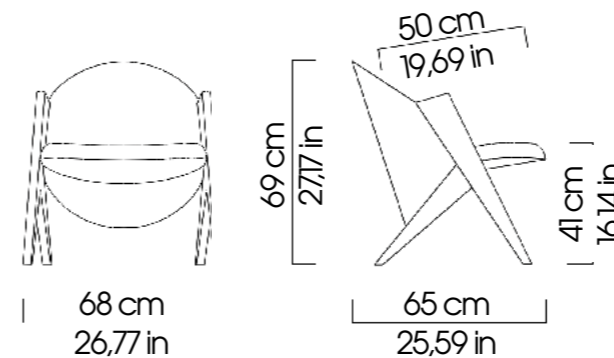

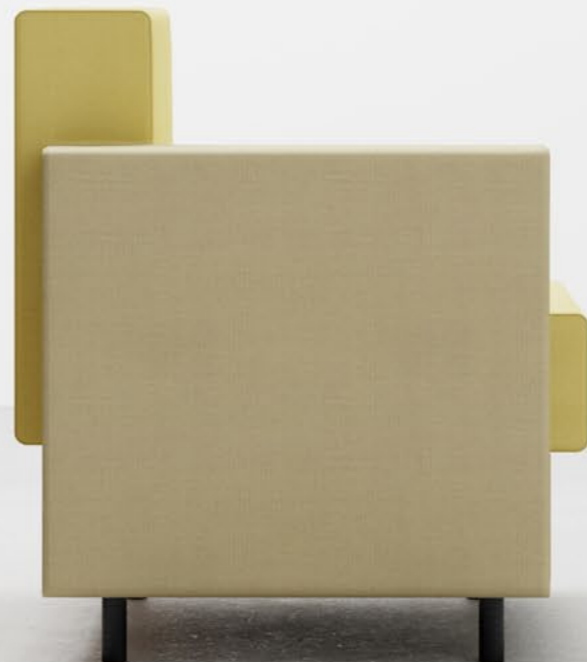



# LAP

Lounge Chair

2019

Neil David Coppens

EN The Lap chair is constructed from the simplicity of two L-shaped elements stacked on each other. With a minimal 90 degree move, they combine to form a cubical seating corner.

NED The Lap fauteuil is opgebouwd uit twee L-vormen die op elkaar gestapeld zijn. Samen vormen ze een kubistisch zit element.

## TECHNICAL SPECIFICATION

Seat and back: Birch plywood construction + foam and fabric  
 Certificates: Birch plywood FSC and PEFC (making use of)  
 Foam and fabric BS 5852 part 2 (Crib5) or CAL 117-2013

## DIMENSIONS CM / INCH

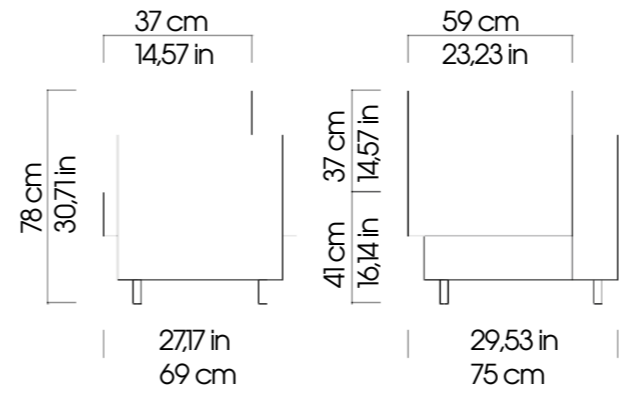

**X**  
Lounge Chair





# X

Lounge Chair

2020

Neil David Coppens

<sup>EN</sup> The chair characterized by the cross shaped back of the frame.

<sup>NED</sup> De stoel kenmerkt zich door de kruisvormige achterkant van het frame.

#### TECHNICAL SPECIFICATION

Seat and back: Beech plywood construction + foam and fabric  
Certificates: Beech plywood FSC and PEFC (making use of)  
Foam and fabric BS 5852 part 2 (Crib5) or CAL 117-2013

#### DIMENSIONS CM / INCH

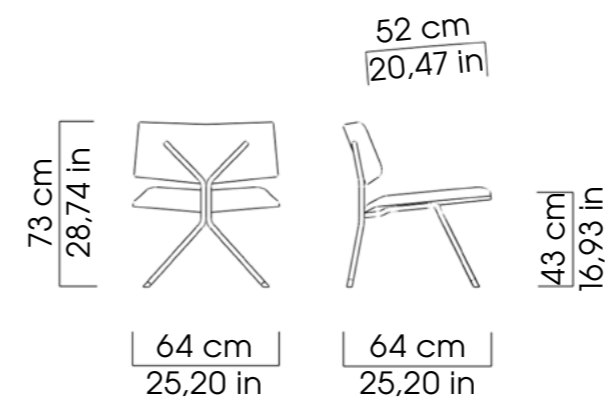

# WOOD FINISH STAINS

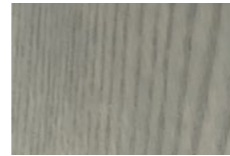

light grey  
licht grijs



natural  
blank



black  
zwart



white  
wit



dark brown  
donker bruin

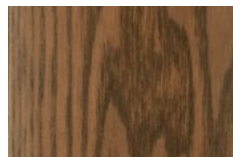

light brown  
licht bruin



blue  
blauw



orange  
oranje



red  
rood

Stain options accentuate the structure of the ash wood, while a matte lacquer finish allows the texture of the grain to show through a denser colour coverage.



**7034**  
yellow grey  
geel grijs

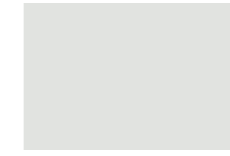

**7035**  
light grey  
licht grijs



**1016**  
yellow  
geel



**9011**  
black  
zwart



**5002**  
ultra blue  
ultra blauw



**5024**  
light blue  
licht blauw



**5003**  
dark blue  
dark blauw

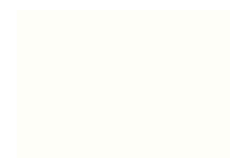

**9010**  
white  
wit

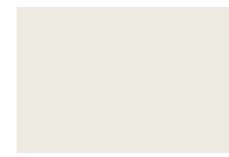

**1013**  
oyster white  
parel wit



**6004**  
blue green  
blauw groen



**3004**  
purple red  
paars rood



**3020**  
red  
rood



**2002**  
orange  
oranje

# WOOD FINISH MATTE COLOR LACQUERS

The matte finish does not influence the true colour of the lacquer.

## POWDER COATS

### MATTE FINE STRUCTURE



**9005**  
black  
zwart

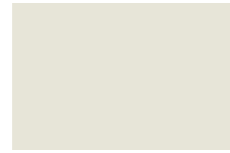

**1013**  
Oyster white  
gebroken wit



**3020**  
Red  
Rood



**3004**  
dark red  
donker rood

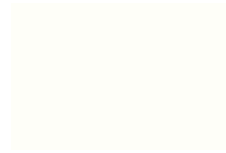

**9010**  
white  
wit



**8014**  
dark brown  
donker bruin

## POWDER COATS

### METALLIC

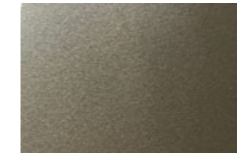

**006**  
Metallic Bronze  
Metallic Brons

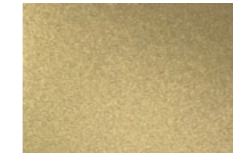

**007**  
Metallic Gold  
Metallic Goud

*Please be advised that the colours on these pages are printed and therefore may differ slightly from the original.*



**F1**  
LOUNGE  
CHAIR



**F1**  
SOFA  
for 2



**F1**  
DINNING  
CHAIR  
*new*



**CHEERS**  
STOOL



**CHEERS**  
UPHOL  
STOOL  
*new*



**F2**  
ARM  
CHAIR



**F2**  
SOFA  
FOR 2  
*new*



**CHEERS**  
DINNING  
CHAIR



**CHEERS**  
UPHOL  
DINNING  
CHAIR  
*new*



**ANGLE**  
LOUNGE  
CHAIR



**ANGLE**  
SOFA  
FOR 2



**ANGLE**  
SOFA  
FOR 3  
*new*



**TWIG**  
LOUNGE  
CHAIR



**BT4**  
SMALL  
TABLE

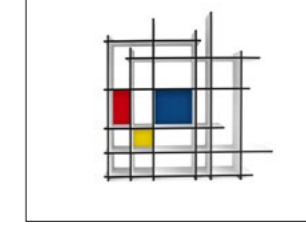

**WABI**  
BOOK-  
CASE



**LAP**  
LOUNGE  
CHAIR



**BARFLY**  
STOOL



**X**  
LOUNGE  
CHAIR  
*new*



## *More information?*

### *Your agent for the USA*

Newton Brown Urban Design  
106 W32nd. Street  
New York, NY 10001  
Tel +1 347 879 4869  
Fax + 1 347 402 2555  
info@newtonbrownusa.com  
www.newtonbrownusa.com  
#nbudusa @nbudusa

### *Neil David is a Dutch design brand*

Weesperstraat 96  
1112 AP Diemen  
Metropolitan Area of Amsterdam  
Tel +31 20 4471507  
info@neildavid.com  
www.neildavid.com

Neil David has the right to change both the design, the material and/or dimensions from this publication with no obligation.

Neil David heeft het recht om veranderingen aan te brengen in zowel ontwerp als materiaal en afmetingen in tegenstelling tot wat er gepubliceerd is zonder waarschuwing.

© 2020 Neil David. All Rights Reserved

---

# Thank you.