

Thoreson-McCosh Inc

Standard Control TD Dryer

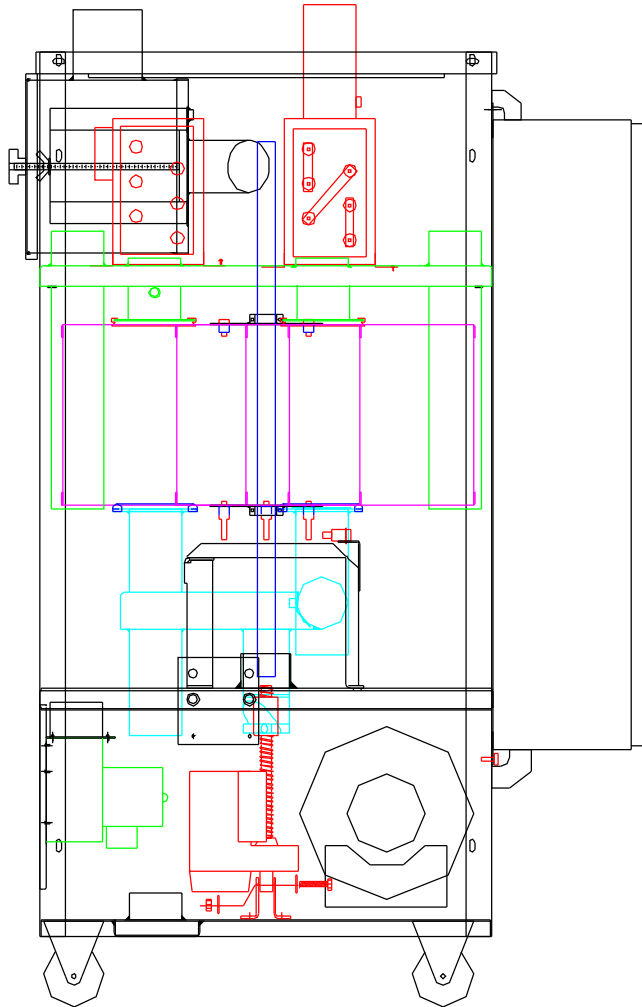

INSTRUCTION MANUAL

IB200302

THORESON-McCOSH INC
1885 Thunderbird St. Troy MI. 48084
Phone 1-248-362-0960
Fax 1-248-362-5270
sales@thoresonmccosh.com
parts@thoresonmccosh.com

Thoreson-McCosh Inc

FORWARD

The information contained in this Instruction Manual is provided to you for the maintenance of your Thoreson-McCosh equipment.

Also included in this manual are operating instructions, a service parts list, and wiring diagrams. Please file this manual for future use.

For additional information, please contact:

THORESON-McCOSH Inc. 1885 Thunderbird Street Troy, MI 48084 Phone: (248) 362-0960 Facsimile: (248) 362-5270 sales@thoresonmccosh.com parts@thoresonmccosh.com

CUSTOMER RECORDS

Upon receipt of your Thoreson-McCosh equipment, it is very important that you complete the table below. The information will be needed to best serve you when you call the Thoreson-McCosh Service Department with questions or to order replacement parts. The information is located on the Serial Tag on the unit and inside the door of the control box.

Model Name _____

Serial No. _____

Wiring Diagram No. _____

Insert No. _____

Program No. _____

Layout No. _____

Table of Contents

SECTION 1: WARRANTY 3

SECTION 2: TD DRYER MECHANICAL METHOD OF OPERATION 4

 2.1: INTRODUCTION 4

 2.2: TRIPLE BED METHOD OF OPERATION 5

 2.3: QUICK START 6

 2.4: POWER CONNECTIONS 6

 2.5: UNITS WITH COMPLETE DRYING HOPPER 7

 2.6: UNITS WITH HOPPER EXTENSION 7

SECTION 3: STANDARD DRYER CONTROLS 8

 3.1: INTRODUCTION 8

 3.2: TURNING THE DRYER ON 9

 3.3: CHANGING THE TEMPERATURE SET POINT 9

 3.4: REGEN BLOWER OFF DELAY TIMER 9

SECTION 4: OPTIONS 10

 4.1: DEW POINT 10

 4.2: DEW POINT SHIFT 10

 4.3: DIRTY FILTER INDICATOR 10

 4.4: BLOWER DIRECTION 10

 4.5: REGEN HEATER FAULT 10

 4.6: REGEN POWER SAVER 10

SECTION 5: PRELIMINARY TD DRYER CHECKS 11

 5.1: VISUALLY CHECKING DRYING SYSTEM 11

 5.2: CHECK THE DRYING HOPPER INLET TEMPERATURE 11

 5.3: CHECK THE HOPPER TEMPERATURE DISTRIBUTION 11

 5.4: CHECK THE DRYER RETURN AIR TEMPERATURE 11

 5.5: CHECK THE DISCHARGE DEWPOINT OF THE DRYER 11

SECTION 6: MAINTENANCE 12

 6.1: FILTERS 12

 6.2: LUBRICATION 12

 6.3: MOLECULAR SIEVE TEST 12

 6.4: FORCING A BED INDEX 12

 6.5: DESICCANT BED RECHARGING PROCEDURE 13

 (TD-12 THRU TD-360) 13

 DESICCANT BED RECHARGING PROCEDURE 14

 (TD-480 THRU TD-2000) 14

 6.6: DEWPOINT SENSOR REPLACEMENT 15

 6.7: DISPOSAL OF MERCURY CONTACTORS 15

 6.8: MAINTENANCE SCHEDULE 16

SECTION 7: TROUBLE SHOOTING ALARMS 17

Thoreson-McCosh Inc

SECTION 8: ADDITIONAL INFORMATION
 TD DRYERS COMMON SPARE PARTS LIST.....
 TD DRYER MECHANICAL SCHEMATICS
 TD DRYER PARTS LIST
 WIRING DIAGRAMS.....
 MERCURY MSDS
 MOLECULAR SIEVE MSDS

Thoreson-McCosh Inc

SECTION 1 THORESON-MCCOSH PRODUCT WARRANTY

Thoreson-McCosh warrants each product of its manufacture to be free from defects in material and workmanship for a period of 30 months (2-1\2) year from the date of delivery to the original purchaser. Thoreson-McCosh's obligation under this warranty is limited to repairing or replacing any part returned to the Thoreson-McCosh factory with transportation charges prepaid, and which, on examination by Thoreson-McCosh, shall disclose to Thoreson-McCosh's satisfaction to have been defective.

The purchaser must notify Thoreson-McCosh of such defects and promptly deliver the defective part(s) in accordance with Thoreson-McCosh's shipping instructions, delivery prepaid. Parts will be replaced F.O.B. Thoreson-McCosh factory, by Thoreson-McCosh, and will be invoiced to the purchaser with "credit on return of defective part", if the part is returned within fifteen (15) days after shipment of replacement part. Thoreson-McCosh is not liable for installation or cost to install the replacement part or removal of the defective part.

Thoreson-McCosh is not responsible for any failure of its product due to improper use, installation, or operation. Thoreson-McCosh shall not assume any expense or liability for repairs made to any Thoreson-McCosh unit or equipment outside Thoreson-McCosh's own factory unless specifically agreed to in writing by Thoreson-McCosh.

Equipment and accessories furnished by us, but manufactured by others, are guaranteed to the extent of the original manufacturer's guarantee to Thoreson-McCosh, if that guarantee exceeds one (1) year.

It is expressly understood that Thoreson-McCosh is not responsible for damage and/or injury caused to buildings, contents, products, or persons by reason of installation or use of any of our products. Thoreson-McCosh shall not be liable for loss, damage or expenses arising directly or indirectly from, or being consequential or incidental to, the use of its products or from any other cause.

The above warranty supersedes, and is in lieu of all other warranties expressed or implied; and no person, agent, representative or dealer is authorized to give any warranties on behalf of Thoreson-McCosh, not to assume for Thoreson-McCosh any other liability in connection with Thoreson-McCosh products.

SECTION 2 TD DRYER MECHANICAL METHOD OF OPERATION

SECTION 2.1 INTRODUCTION

Your Thoreson-McCosh dryer was thoroughly tested prior to shipment and checked to insure that its performance is up to specifications. Upon arrival in your plant, the unit should be carefully inspected for physical damage which might have occurred in transportation. Should any damage be observed, it should be reported to the carrier at the earliest possible time.

Dryers are held to the crate bottom with a Z bracket. The side panels must be removed before the Z brackets can be removed. Use a hi-low or a lift to raise the unit off of the crate bottom. We recommend that a person steady the unit while on the hi-low.

For TD-480 and up, there are cross supports and some wood supports to secure the beds during shipping, these must be removed before power and air are connected to the unit. Failure to remove these items will damage the unit.

The dryer should be located as close as possible to the material drying hopper it will service. This will minimize thermal and air flow losses. The unit should be placed on any reasonable level area or platform. The unit should be connected to the power source indicated on the model nameplate. If the return air temperature will be above 165°F/ 74°C, than an After-Cooler should be installed into your unit.

This dryer is a triple desiccant bed unit which continuously removes moisture from the process air stream by adsorption. While two of the beds are adsorbing moisture from the process air, the third is being automatically recharged.

This unit is a re-circulating dryer, recycling the drying air from the material hopper through the desiccant beds. The regeneration air flow is completely independent of the process air flow. The only atmospheric air that enters the process system is a small quantity which may leak in via the material loading system, if present on the hopper. A process air filter and regeneration air filter are provided to prevent contaminants from reaching the desiccant material.

SECTION 2.2 TRIPLE BED METHOD OF OPERATION

The operation of the triple bed dryer is based on each of the three beds being indexed to one of three separate stations within the unit.

The first position is the regeneration station. Here, super-heated ambient air is blown through the bed to remove adsorbed moisture from the desiccant material. This moisture is exhausted to the atmosphere near the bottom of the dryer.

The second position is the cool down station. Here, a small percentage of return air from the hopper passes through the bed to gradually cool down the hot desiccant material. The heat captured by this air is used to heat the process air, thus minimizing process heater energy requirements. As the bed cools, it begins to contribute to the material drying process.

The third position is the process station. Here, the rest of the return air from the hopper passes through this desiccant bed. The dried, cooled, desiccant material is now permitted to adsorb any moisture removed from the plastic resin that is carried in with the return air, before it is heated and sent back to the drying hopper in a completely closed loop cycle.

Automatic indexing of the beds is performed by separating the manifolds upper and lower airflow from the desiccant beds with an electric lineal actuator motor. The beds are then rotated with a gear motor/chain drive assembly. A limit switch stops the beds at the next sequential station. The lineal actuator motor then clamps the manifold seals located on the upper and lower air flow manifolds against the beds for an airtight operation.

On standard units, the automatic bed indexing time cycle is controlled by a solid state timer, which is set properly to guarantee very dry process air, even while operating under extremely severe drying conditions.

In the optional dewpoint control mode, the dewpoint of the process air is continuously monitored. Automatic bed indexing will occur only when the cycle time has expired and the dew point is approaching an unacceptable level. (-7 °F/ -22°C)

The process air heating elements are located in the heater box, which is nearest the control box mounted on the upper deck.

The regeneration air heating elements are located in the heater box, on the upper deck, furthest from the control box. On standard units the regeneration heater and blower are timed to be on during the first portion of the bed index cycle, and off during the remainder of the cycle. Only units with the optional **regeneration power saver**, the heaters and blower will shut off early if the regeneration of the bed is sensed as being completed (regeneration exhaust temperature reaches a minimum of 325°F/ 163°C). An indicating light is provided to indicate when the regeneration heater elements are on.

SECTION 2.3 QUICK START

NOTE: Please read this section, as it contains information not found elsewhere in the manual. Most steps will refer you to the correct section for reference.

1. Uncrate equipment (Section 2.1).
2. Clean drying hopper. All hoppers are shipped with a light coat of oil.
3. Connect power. (Section 2.4)
4. Connect water lines to after-cooler (optional equipment). Requires 3 to 4 gallons per minute, maximum 100 P.S.I., 80°F/ 27°C.
5. Connect compressed air to the units requiring compressed air. (TD-480 & up). 60 P.S.I. minimum, 120 P.S.I. maximum.
6. Check process blower rotation (Section 2.4).
7. Connect Air hoses. The smaller diameter red process hose connects from the dryer to the diffuser on the hopper. The black hose returns air from the connection near the top of the hopper back to the dryer unit.
8. Set process temperature setpoint (Section 4).
9. Visually inspect drying system (Section 9.1).
10. Fill hopper with material.
11. Begin drying, giving first batch of material sufficient residence time before beginning to use material (typically 3 to 4 hours). Check with resin manufacturer.

SECTION 2.4 POWER CONNECTIONS

The power line terminals are identified as L1, L2, and L3. All heater and blower circuits are individually fused. It is highly recommended, and required by many local codes, that a fusible disconnect of adequate capacity be installed by user. The unit is ready to operate after connecting the power lines to their respective terminals and properly grounding the machine.

Blower motor rotation on three phase units must be checked when the unit is first started and after any reconnection of power to the unit.

The Blower Rotation Alarm is optional. If the alarm is not included on your dryer, you must check that the process blower is rotating in the right direction by removing the side panel and checking that the process blower motor is rotating clockwise.

To correct the blower rotation, reverse any two of the three incoming power leads to the terminal block. Do not swap the power leads at the blower itself.

CAUTION: The correct phase is extremely important. Incorrect phasing can damage the dryer.

SECTION 2.5 UNITS WITH COMPLETE DRYING HOPPER

Clean the inside of your hopper thoroughly to avoid contamination of plastics resin to be processed. Install the balanced flow air diffuser inside of the drying vessel with the mounting plate and bolts supplied. Your drying hopper is made in two sections for ease of cleaning and installation. To remove the barrel of the hopper, lift it out of its “seat” on the hopper cone. If you have purchased a machine-mounted hopper, install the hopper cone mounting plate to the feed throat of your molding machine, being sure that it is well secured. Refit the hopper barrel into its “seat” on the hopper cone, being sure that it is located and clamped properly with the stainless steel ring clamp provided.

NOTE: The T-bolt should have a light application of grease on the threads or the T-bolt will score and lock-up in the clamp.

SECTION 2.6 UNITS WITH HOPPER EXTENSIONS

Clean the inside of your extension thoroughly to avoid contamination of plastic resin. Install the balanced flow air diffuser with the mounting plate and bolts supplied.

Place the extension on your machine hopper, being sure that the extension is centrally located on the machine hopper and properly secured.

SECTION 3 STANDARD DRYER CONTROLS

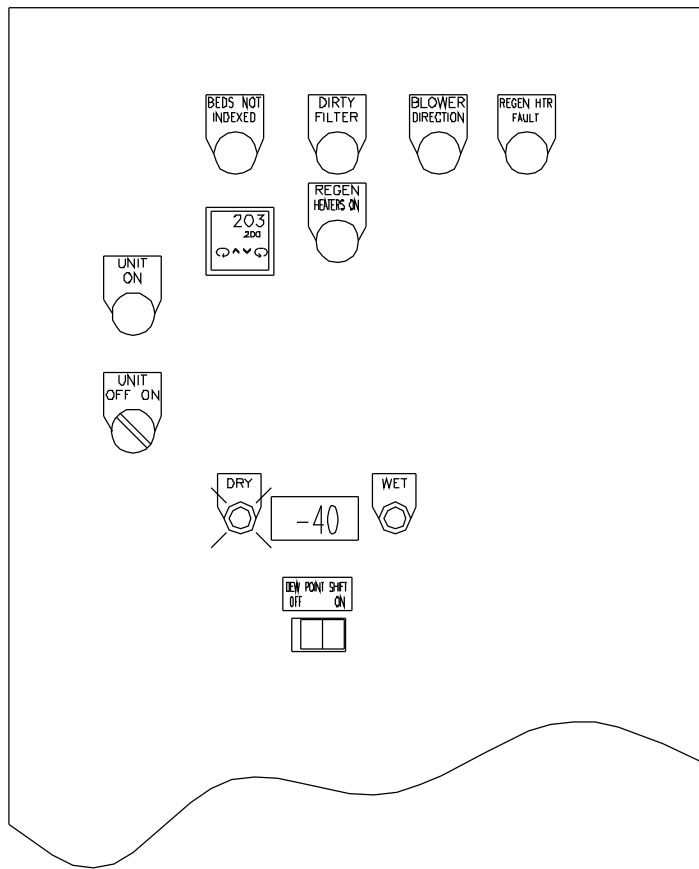

FIGURE 3.1 STANDARD DRYER CONTROLS:

SECTION 3.1 INTRODUCTION

Standard Controls include:

- UNIT OFF/ON SWITCH
- DIGITAL TEMPERATURE CONTROL
- UNIT ON INDICATOR
- REGEN HEATER ON INDICATOR
- BEDS NOT INDEXED WARNING INDICATOR

Options:

- DIGITAL DEW POINT WITH WET & DRY INDICATORS
- DEW POINT WITH SHIFT CONTROL
- DIRTY FILTER INDICATOR
- REGEN HEATER FAULT INDICATOR
- BLOWER DIRECTION INDICATOR

SECTION 3.2 TURNING THE DRYER ON

To turn the dryer on, turn the Unit Off/On selector switch to the On position. The Process Blower will energize and the timing sequence will commence. Depending on the size of the dryer, the Cycle and Regen time will vary. Check your Wiring Diagram or Dryer Insert for your Cycle and Regen times.

After setting the Process temperature set point, the dryer will cycle on the timer, with no more need to monitor or change any settings.

SECTION 3.3 CHANGING THE TEMPERATURE SET POINT

The dryer comes standard with a digital temperature control. The control displays the actual Process temperature and the Process temperature set point. To increase or decrease the temperature, push the up or down indicators on the face of the control, until it displays the desired temperature set point. The Process temperature set point can be selected from 0 to 400°F. The unit is shipped with normal factory defaults. To deviate from the normal settings, refer to the Temperature Control literature included in the Dryer Instruction Manual.

We recommend that the normal factory settings be used. Failure to use these settings, can result in damage to the unit. Consult the service department before making changes.

SECTION 3.4 REGEN BLOWER OFF-DELAY TIMER

The Regen Blower Off-Delay Timer allows additional cooling of the regenerated desiccant bed and is adjustable from 10 to 1000 seconds with a trim pot on the timer.

Regeneration of the desiccant beds is accomplished by blowing extremely hot (550°F/ 288°C) ambient air through the desiccant for a predetermined length of time. The blower and heaters then shut off until the process cycle is complete. Normal cooling is accomplished through static (conduction) heat transfer during the remainder of the process cycle, then through convection while the bed is in the cool down position during the next process cycle. This is accomplished by bleeding off a small portion of the process air through the lower air flow manifold and then thru the desiccant bed, recapturing this air in the process heater box. This cools down the bed and allows reuse of the energy used to regenerate the bed.

However, because desiccant, as it captures moisture gives off heat, this energy and the heat from the bed that is cooling down can make it very difficult to attain low process temperatures (<150°F/ 66°C). Therefore, we have made it possible to extend the regen blower running time with the regen heaters off. This allows the convective cooling to be achieved before the bed rotates to the cool down position. The danger is that the ambient air will introduce some moisture as the bed cools down, thereby reducing the effectiveness of the desiccant to dry the process air. This is less of a danger than letting the process air stream go open loop, because desiccant will not adsorb moisture until its temperature is below approximately 200°F/ 93°C. Thoreson-McCosh would not recommend using the off-delay unless necessary, and recommends that the dryer be monitored closely to determine the effect of the time delay, as ambient conditions change, and plastic resin differ in acceptable process applications.

SECTION 4 OPTIONS

SECTION 4.1 DEW POINT

The digital dew point meter will display the Dew Point of the Process Air just before it exits the process heater box. The lights are factory set to change from wet to dry at -7°F.

SECTION 4.2 DEW POINT SHIFT

All Thoreson-McCosh material dryers have been designed to operate at -40° dew point. The dew point shift option keeps the desiccant beds from shifting until its set point is reached. Taking the dryer unit off the time line schedule and allowing the desiccant bed to continue to saturate with moisture until it reaches a Dew Point of -7° F. The dryer will incur fewer regeneration cycles. Fewer regeneration cycles means a huge reduction of standard operating cost. (NOTE: Minimum time is the standard cycle time preset at the factory). That is, the beds do not shift until the dew point of the process stream reaches the set point value after the cycle timer has timed out.

SECTION 4.3 DIRTY FILTER INDICATOR

When the process filter gets dirty, the Dirty Filter warning light will come on.

SECTION 4.4 BLOWER DIRECTION

With this option, when the Dryer is first installed or moved to a different location, the Blower Direction warning light will come on if the Blower is turning backwards.

SECTION 4.5 REGEN HEATER FAULT

The Regen Heater Fault Indicator comes on if the current sensors on the Regen Heater wires don't sense the proper current flowing through the wires. This indicates an open heater element, or a blown fuse in the Regen circuit or the Power supplied to the Dryer.

SECTION 4.6 REGEN POWER SAVER

The Regen Power Saver option, senses the temperature coming out of the Regenerating Bed and when the temperature reaches a value of 325°F, disables the Regen heaters for the remainder of the Cycle.

SECTION 5 PRELIMINARY TD DRYER CHECKS

SECTION 5.1 VISUALLY CHECK DRYING SYSTEM

Check dryer hoses and hopper. Be sure that delivery and return hoses are in good condition routed with a minimum of length and sharp bends. Hopper lid should be in place and well sealed. If a hopper loader is used, it should be mounted so that drying air leakage is minimized.

SECTION 5.2 CHECK DRYING HOPPER INLET TEMPERATURE

At the hopper air inlet, the drying temperature should match the recommended temperature specified by the material supplier. In general, as hot as possible without allowing thermal degradation or discoloration of the material being processed. If the hopper inlet temperature is lower than the dryer discharge, the dryer temperature setpoint should be increased to compensate for the temperature drop in the process air flow hose.

SECTION 5.3 CHECK THE HOPPER TEMPERATURE DISTRIBUTION

Let dryer run for 3 - 4 hours. Air/material temperature in the hopper should be uniform around the hopper at any level, and hot (within 15°F/ 9°C of inlet temperature) up to 80% of the full hopper height when material is being added at the designed drying rate. Under static drying conditions (no new material added to hopper) the discharge temperature should approach inlet temperature after approximately 4-5 hours of operation. Should these checks show that the heat is not progressing upward through the hopper, the dryer should be checked for low airflow.

SECTION 5.4 CHECK DRYER RETURN AIR TEMPERATURE

After 4 hours of residence time, check the return air temperature. If the return air temperature exceeds 165°F / 74°C, then your unit should be equipped with some kind of After-Cooler. This will protect the process blower and allow the desiccant to work at optimum efficiency.

SECTION 5.5 CHECK DISCHARGE DEW POINT OF DRYER

For standard dryers, it should be approximately -40°F/ -40°C or lower. Should the dew point run higher than specified, check the dryer, hopper and all hoses for leaks.

SECTION 6 MAINTENANCE

SECTION 6.1 FILTERS

The process and regeneration filters should be checked weekly and cleaned with compressed air or replaced if necessary, important remember to check the filter gasket and fix or replace as needed.

SECTION 6.2 LUBRICATION

The regeneration blower motor bearings may be lubricated every 6 months to extend blower life. A couple drops of S.A.E. 20 motor oil at each of the two motor bearings is recommended.

SECTION 6.3 MOLECULAR SIEVE TEST

When it is suspected that the molecular sieve needs replacement, there is a simple test that can be performed. A positive test does not ensure that the molecular sieve is in good condition. If there is a large percentage of broken pellets or dust, contamination from foreign matter, or most of the pellets are discolored, the desiccant should be replaced. New desiccant is light tan in color.

To test the desiccant's effectiveness, a sample should be regenerated in an oven at 600°F/ 316°C for about two hours. At the end of that period, place the desiccant into an air tight jar and allow it to cool down to room temperature for a minimum of 12 hours. Pour 30ml of water into a small glass. Determine and record the temperature of the water using a mercury thermometer. Into a similar dry glass, pour a quantity of desiccant that is 10% greater by volume than the water (33ml). Dry the thermometer and place it into the glass containing molecular sieve. With one quick motion, pour the water into the glass of desiccant. Observe the increase in temperature of the mixture while stirring with the thermometer and record the peak temperature. This will occur in about 20 to 30 seconds. Subtract the water temperature from peak temperature observed. If the temperature difference is 40°F/ 4°C or greater, the sieve is in satisfactory condition.

SECTION 6.4 FORCING A BED INDEX

It becomes necessary to shift the beds for maintenance and for trouble shooting the unit. With standard controls, the simple way to shift the beds is to disconnect power from the unit. Disconnect the neutral wire from the coil of 1TR. Reconnect power to the unit. The beds will pull down and start to rotate. As soon as the beds rotate and open the bed indexing limit switch, Disconnect the power again and re-connect the neutral to 1TR. Re-connect the power, and the beds will finish rotating and push-up when the indexing limit switch is closed.

SECTION 6.5 DESICCANT BED RECHARGING PROCEDURE

FOR TD-12 THROUGH TD-360

Read instructions completely before attempting to remove the beds.

1. Set Off/Auto/On switch to On, Set key switch to "Adjust Setpoints".
2. Remove side panels.
3. Follow the procedure in Section 6.4 "Forcing a Bed Index". When the beds are clear of the manifolds, remove power from the dryer.

Note: Do not turn the dryer off with the OFF/AUTO/ON switch. The manifold will clamp up against the beds.

4. Loosen the band clamps that hold the bed tight up against the turret plates, and remove the bed from the unit. Remove the band clamps
5. Apply power and repeat items 3 and 4 until all the beds have been removed.

Note: On some units, The bed turret assembly can be manually rotated if care is taken to rotate them slowly, and always in a left to right direction.

Inspect the center cavity at the top of the bed for any quantity of beads, which may indicate a damaged inner perforate screen.

Inspect the bottom part of the bed for the presence of any loose beads, which may indicate a damaged outer screen. If when the beds are refilled and there is evidence of bead leakage, the bed must be repaired or replaced.

To replace the desiccant:

- a) Remove the bed bead plate to gain access to the desiccant.
- b) Dump the desiccant beads out and vacuum the remaining beads out.
- c) Fill the beds with new desiccant - use only 4a type 8 x 12 size (0.080" diameter) desiccant beads. Fill beds as full as possible. Rock or vibrate the beds to promote settling of the beads. Add more desiccant to fill the beds and pack tight without breaking beads.
- d) Apply high temperature sealant (G.E. silicone RTV-106n sealant is recommended) and secure bed bead plates to beds.
- e) Reverse the bed removal procedure to replace the beds. Lift the beds into the dryer with bed bead plates up and positioned outward from the shaft. Make sure that the bolts for the band clamps are not strait out from the shaft. (The bolts can catch on frame parts and stall the rotate motor)
- f) Secure the beds tight against the turret plate with the band clamps.
- g) Start the dryer and let it operate for a few bed shift cycles while inspecting for leaks at the upper and lower bed seals.
- h) Shut off dryer and install side panels.
- i) After approximately 1-2 weeks of dryer operation check the bead level and add more desiccant if needed.

FOR TD-480 THROUGH TD-2000

Read instructions completely before attempting to remove the beds.

1. Set Off/Auto/On switch to On, Set key switch to "Adjust Setpoints".
2. Remove side panels.
3. Follow the procedure in Section 6.4 "Forcing a Bed Index". When the manifolds have pulled away from the beds, remove the 4CR (bed shift relay) from its socket. Place a 1" block inside of the upper and lower air cylinders. (2 if a single piston air cylinder). Remove the compressed air from the unit and make sure that the bed seals are far enough away from the beds to be able to slide the beds out of the turret plate. Remove power from the dryer.
4. Loosen the rotate motor bracket and remove the rotate chain. If there is not enough adjustment to remove the chain, use the master link to break the chain.
5. Using a HI-LO, place the forks on both sides of the manifold tube over the process blower. Lift the forks till just touching the beds. (DO NOT LIFT THE BED) Remove the bolts that hold the band clamps together and remove the bed by backing the HI-LO out of the unit.
6. Rotate the beds from left to right by hand so the next bed is in the same position as the first bed removed.
7. Repeat instructions 5 and 6 for the rest of the beds.

Inspect the center cavity at the top of the bed for any quantity of beads, which may indicate a damaged inner perforate screen.

Inspect the bottom part of the bed for the presence of any loose beads, which may indicate a damaged outer screen. If when the beds are refilled and there is evidence of bead leakage, the bed must be repaired or replaced.

To replace the desiccant:

- a) Remove the bed bead plate to gain access to the desiccant.
- b) Dump the desiccant beads out and vacuum the remaining beads out.
- c) Fill the beds with new desiccant - use 4a type 8 x 12 size (0.080" diameter) desiccant beads only. Fill beds as full as possible. Rock the beds to promote settling of the beads. Add more desiccants to fill the beds and pack tight without breaking beads.
- d) Apply high temperature sealant (G.E. silicone RTV-106n sealant is recommended) and secure bed bead plates to beds.
- e) Lift the beds into the dryer with bed bead plates up and positioned outward from the shaft.
- f) Reverse the bed removal procedure to replace the beds. Make sure that the bolts for the band clamps are not straight out from the shaft. (The bolts can catch on frame parts and stall the rotate motor) and the lid clamp pads on the top of the bed don't touch the turret plate alignment bushings.
- g) Start the dryer and inspect for leaks at the upper and lower bed seals. Force a shift to check the seals on all beds in all positions.

SECTION 6.6 DEWPOINT SENSOR REPLACEMENT

The dewpoint sensor should be replaced once a year or when contaminated.

Note: Never attempt to measure the resistance of the sensor. This will damage the sensor.

To replace the sensor:

1. Remove power from the unit.
2. Locate the sensor manifold assembly. This is a manifold (block) with wires coming from the socket to the dewpoint board.
3. Remove socket.
4. Unscrew retaining nut.
5. Remove sensor and insert from manifold.
6. Remove the insert from the sensor. Place the insert onto the new sensor.
7. Reverse steps 1-5.

SECTION 6.7 DISPOSAL OF MERCURY CONTACTORS

When a mercury contactor needs to be replaced, care must be taken to properly dispose of the defective unit. Remove the contactor and place it in a plastic baggy and seal the bag. Then place the unit or units in a sealable 5 gallon steel drum. If the unit is under Thoreson-McCosh's factory warranty, ship to Thoreson-McCosh for warranty replacement credit. If the unit is no longer under warranty, please contact:

Bethlehem Apparatus
P.O. Box 890
Front St.
Hellertown. PA 18055
Ph: (215) 838-7034

SECTION 6.8 MAINTENANCE SCHEDULE

TO BE USED IN CONJUNCTION WITH DRYER INSTRUCTION MANUAL

DRYER#:

DATE:

SPECIAL INSTRUCTIONS:

WEEKLY

CHECK AND CLEAN OR REPLACE FILTERS

CHECK FOR UNUSUAL NOISE

CHECK PROCESS DEWPOINT (MAX.=-40°F)

CHECK SYSTEM FOR AIR LEAKS (HOSES, HOPPER)

SEMI-ANNUALLY

OIL REGENERATION BLOWER MOTOR BEARINGS

CHECK BED INDEXING

CHECK LIGHTS

CHECK CONTACTS

CHECK AMP DRAW OF HEATERS AND BLOWER MOTORS

(SEE WIRING DIAGRAM , INSERT AND INDIVIDUAL MOTORS NAME PLATE)

ANNUALLY

REPLACE DEW POINT SENSOR

TEST MOLECULAR SIEVE

GREASE SHAFT BEARINGS AT TOP AND BOTTOM OF BEDS

(SUGGESTED GREASE: DOW CORNING #41 EXTREME HIGH TEMP. BEARING
GREASE OR EQUIVALENT

SECTION 7 TROUBLE SHOOTING ALARMS

INDICATOR LIGHT

BEDS NOT INDEXED Cycle timer has timed out, and the
..... beds failed to index.

Check that the Push-up motor is in the down position, and that there is power to the rotate motor. **(check at the control terminal block in the control box)**. If there is power to the rotate motor but it doesn't rotate, replace the rotate motor. If the rotate motor has no power, check to see if there is power to the black wire of the push-up motor. If there is power there, the push-up motor will need to be replaced. If there is no power there, back track the circuit to the relay and 1TR to see if either of them are bad.

FILTER DIRTY Clean or replace the Process filter.

REGEN HEATER FAULT Low current draw to Regen heaters
Disconnect power from the unit. Check the Regen heater fuses and ohm the heaters to see if they are open. Replace fuses and heaters that are bad.

BLOWER DIRECTION Incorrect phasing of the high power
Interchange any 2 leads of the incoming power.

Thoreson-McCosh Inc

TD DRYERS COMMON SPARE PARTS LIST

MODEL	MANIFOLD UPPER SEAL	MANIFOLD LOWER SEAL	PROCESS FILTER	REGEN FILTER	DEW POINT SENSOR	MANIFOLD SEPARATION DEVICE	BED INDEX MOTOR
TD-6	413987 (3PCS)	413987 (3PCS)	404663	404663	-----	413989	409650
TD-12	413987 (3PCS)	413987 (3PCS)	410086	404663	411335	410213	409650
TD-24	413987 (3PCS)	413987 (3PCS)	410086	404663	411335	410213	409650
TD-40	413860 (3PCS)	413861 (3PCS)	409951	404654	411335	410213	409650
TD-60	413860 (3PCS)	413861 (3PCS)	409951	404654	411335	410213	409650
TD-90	413860 (3PCS)	413861 (3PCS)	409951	404654	411335	410213	409650
TD-120	413860 (3PCS)	413861 (3PCS)	409951	404654	411335	410213	409650
TD-150	413985 (3PCS)	413986 (3PCS)	410598	404648	411335	410213	410713
TD-180	413985 (3PCS)	413986 (3PCS)	410598	404648	411335	410213	410713
TD-240	413985 (3PCS)	413986 (3PCS)	410598	404648	411335	410213	410713
TD-360	413985 (3PCS)	413986 (3PCS)	410598	404648	411335	410213	410713
TD-480	411204 (3PCS)	411204 (3PCS)	404658	409951	411335	Call Factory	410713
TD-600	411204 (3PCS)	411204 (3PCS)	404658	409951	411335	Call Factory	410713
TD-800	411204 (3PCS)	411204 (3PCS)	404658	409951	411335	Call Factory	410713
TD-1000	410865 (3PCS)	410865 (3PCS)	404658 (2PCS)	409951	411335	Call Factory	413663
TD-1500	410865 (3PCS)	410865 (3PCS)	404658 (2PCS)	404656	411335	Call Factory	413663
TD-2000	411792 (3PCS)	411792 (3PCS)	404658 (3PCS)	404656	411335	Call Factory	413663

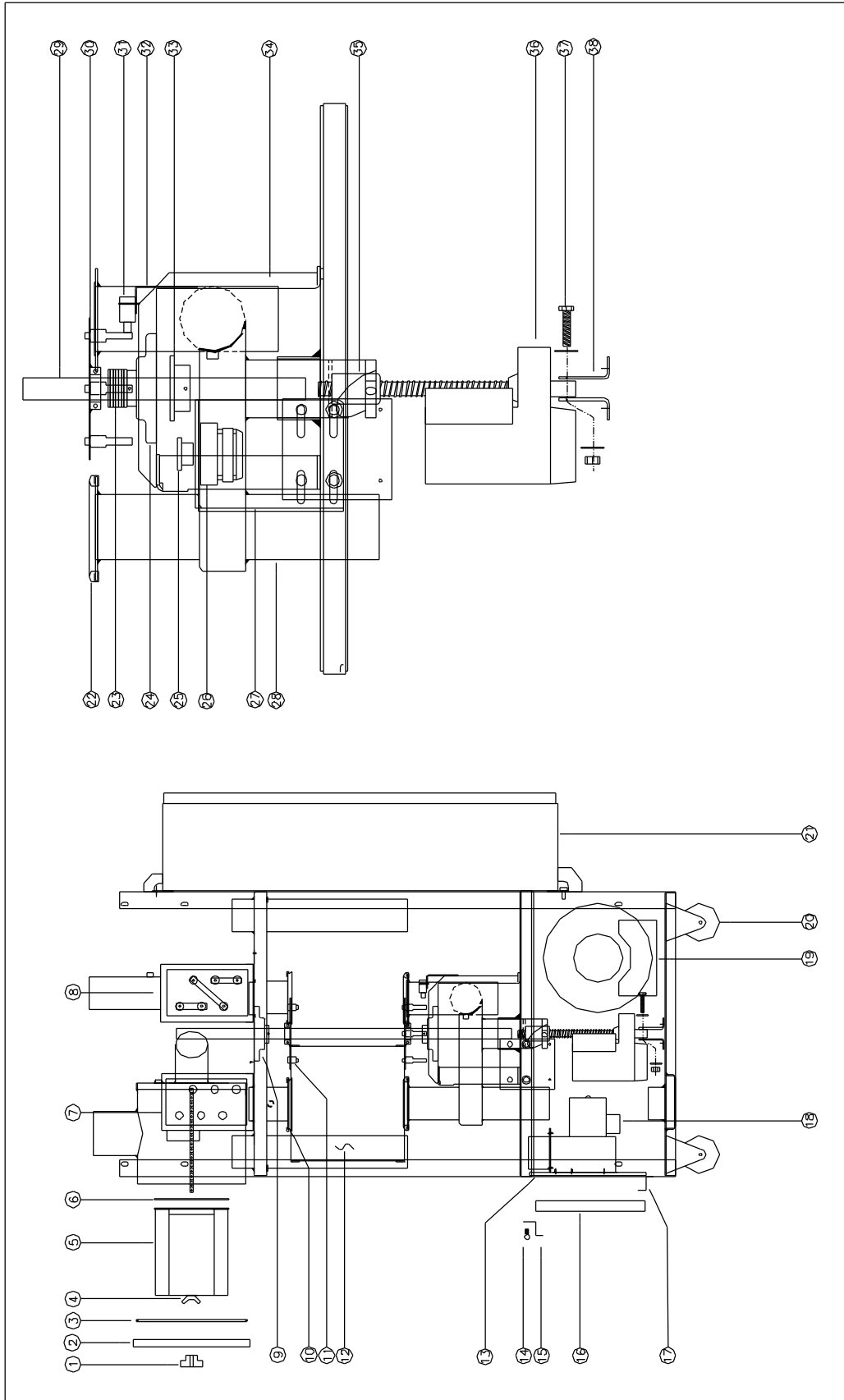

Thoreson-McCosh Inc

40	X	---	
39	X	---	
38	2	PUSH-UP MOTOR BRACKETS	
37	1	SHOULDER BOLT, LOCK-NUT, 2 WASHERS	
36	1	PUSH-UP MOTOR	
35	1	PUSH-UP MOTOR NUT	
34	1	LOWER BEARING SUPPORT ASSEMBLY	
33	1	SHAFT GEAR	
32	1	BED INDEX LIMIT SWITCH BRACKET	
31	1	BED INDEX LIMIT SWITCH	
30	1	LOWER TURRET PLATE	
29	1	BED SHAFT	
28	1	MANIFOLD	
27	1	ROTATE MOTOR BRACKET	
26	1	ROTATE MOTOR	
25	1	ROTATE MOTOR GEAR	
24	1	LOWER BEARING	
23	X	SHIMMS, AM'T VARIES TO MAINTAIN MAX 3/8" GAP	
22	3	LOWER BED SEAL	
21	1	ELECTRICAL CONTROL ENCLOSURE	
SYM.	AM'T		DESCRIPTION

20	4	CASTERS, 2 SWIVEL, 2 RIDGID	
19	1	PROCESS BLOWER	
18	1	REGEN BLOWER	
17	1	LOWER REGEN FILTER BRACKET	
16	1	REGEN FILTER BRACKET	
15	1	UPPER REGEN FILTER BRACKET	
14	1	THUMB SCREW	
13	1	REGEN FILTER GASKET	
12	3	DESICCANT BED	
11	1	UPPER TURRET PLATE	
10	3	UPPER BED SEAL	
9	1	UPPER BEARING	
8	1	PROCESS HEATER BOX	
7	1	REGEN HEATER BOX	
6	1	PROCESS FILTER GASKET	
5	1	PROCESS FILTER	
4	1	WING NUT WITH FLAT WASHER	
3	1	PROCESS FILTER COVER GASKET	
2	1	PROCESS FILTER COVER	
1	1	KNOB	
SYM.	AM'T		DESCRIPTION

Thoreson-McCosh Inc

MSDS Material Safety Data Sheet

From: Mallinckrodt Baker, Inc.
222 Red School Lane
Phillipsburg, NJ 08865



24 Hour Emergency Telephone: 908-859-2151
CHEMTREC: 1-800-424-9300

National Response in Canada
CANUTEC: 613-996-6666

Outside U.S. and Canada
Chemtrec: 703-527-3887

NOTE: CHEMTREC, CANUTEC and National Response Center emergency numbers to be used only in the event of chemical emergencies involving a spill, leak, fire, exposure or accident involving chemicals.

All non-emergency questions should be directed to Customer Service (1-800-582-2537) for assistance.

MERCURY

MSDS NUMBER: M1599 --- EFFECTIVE DATE: 07/09/2001

1. PRODUCT IDENTIFICATION

Synonyms: Quicksilver; hydrargyrum; Liquid Silver

CAS No.: 7439-97-6

Molecular Weight: 200.59

Chemical Formula: Hg

Product Codes:

J.T. Baker: 2564, 2567, 2569, 2572

Mallinckrodt: 1278, 1280, 1288

2. COMPOSITION/INFORMATION ON INGREDIENTS

Ingredient	CAS No	Percent	Hazardous
Mercury	7439-97-6	90 - 100%	Yes

3. HAZARDS IDENTIFICATION

Emergency Overview

DANGER! CORROSIVE. CAUSES BURNS TO SKIN, EYES, AND RESPIRATORY TRACT. MAY BE FATAL IF SWALLOWED OR INHALED. HARMFUL IF ABSORBED THROUGH SKIN. AFFECTS THE KIDNEYS AND CENTRAL NERVOUS SYSTEM. MAY CAUSE ALLERGIC SKIN REACTION.

J.T. Baker SAF-T-DATA^(tm) Ratings (Provided here for your convenience)

Health Rating: 4 - Extreme (Poison)

Flammability Rating: 0 - None

Thoreson-McCosh Inc

Reactivity Rating: 1 - Slight

Contact Rating: 3 - Severe (Life)

Lab Protective Equip: GOGGLES; LAB COAT; VENT HOOD; PROPER GLOVES

Storage Color Code: Blue (Health)

Potential Health Effects

Inhalation:

Mercury vapor is highly toxic via this route. Causes severe respiratory tract damage. Symptoms include sore throat, coughing, pain, tightness in chest, breathing difficulties, shortness of breath, headache, muscle weakness, anorexia, gastrointestinal disturbance, ringing in the ear, liver changes, fever, bronchitis and pneumonitis. Can be absorbed through inhalation with symptoms similar to ingestion.

Ingestion:

May cause burning of the mouth and pharynx, abdominal pain, vomiting, corrosive ulceration, bloody diarrhea. May be followed by a rapid and weak pulse, shallow breathing, paleness, exhaustion, tremors and collapse. Delayed death may occur from renal failure. Gastrointestinal uptake of mercury is less than 5% but its ability to penetrate tissues presents some hazard. Initial symptoms may be thirst, possible abdominal discomfort.

Skin Contact:

Causes irritation and burns to skin. Symptoms include redness and pain. May cause skin allergy and sensitization. Can be absorbed through the skin with symptoms to parallel ingestion.

Eye Contact:

Causes irritation and burns to eyes. Symptoms include redness, pain, blurred vision; may cause serious and permanent eye damage.

Chronic Exposure:

Chronic exposure through any route can produce central nervous system damage. May cause muscle tremors, personality and behavior changes, memory loss, metallic taste, loosening of the teeth, digestive disorders, skin rashes, brain damage and kidney damage. Can cause skin allergies and accumulate in the body. Repeated skin contact can cause the skin to turn gray in color. A suspected reproductive hazard; may damage the developing fetus and decrease fertility in males and females.

Aggravation of Pre-existing Conditions:

Persons with nervous disorders, or impaired kidney or respiratory function, or a history of allergies or a known sensitization to mercury may be more susceptible to the effects of the substance.

4. FIRST AID MEASURES

Inhalation:

Remove to fresh air. If not breathing, give artificial respiration. If breathing is difficult, give oxygen. Get medical attention immediately.

Ingestion:

Induce vomiting immediately as directed by medical personnel. Never give anything by mouth to an unconscious person. Get medical attention immediately.

Skin Contact:

Immediately flush skin with plenty of water for at least 15 minutes while removing contaminated clothing and shoes. Get medical attention immediately. Wash clothing before reuse. Thoroughly clean shoes before reuse.

Eye Contact:

Immediately flush eyes with plenty of water for at least 15 minutes, lifting lower and upper eyelids occasionally. Get medical attention immediately.

5. FIRE FIGHTING MEASURES

Fire:

Not considered to be a fire hazard.

Explosion:

Not considered to be an explosion hazard.

Fire Extinguishing Media:

Use any means suitable for extinguishing surrounding fire. Do not allow water runoff to enter sewers or waterways.

Special Information:

In the event of a fire, wear full protective clothing and NIOSH-approved self-contained breathing apparatus with full facepiece operated in the pressure demand or other positive pressure mode. Undergoes hazardous reactions in the presence of heat and sparks or ignition. Smoke may contain toxic mercury or mercuric oxide. Smoke may contain toxic mercury or mercuric oxide.

6. ACCIDENTAL RELEASE MEASURES

Ventilate area of leak or spill. Clean-up personnel require protective clothing and respiratory protection from vapor. Spills: Pick up and place in a suitable container for reclamation or disposal in a method that does not generate misting. Sprinkle area with sulfur or calcium polysulfide to suppress mercury. Do not flush to sewer. US Regulations (CERCLA) require reporting spills and releases to soil, water and air in excess of reportable quantities. The toll free number for the US Coast Guard National Response Center is (800) 424-8802.

Thoreson-McCosh Inc

J. T. Baker CINNASORB(R) and RESISORB(R) are recommended for spills of this product.

7. HANDLING AND STORAGE

Keep in a tightly closed container, stored in a cool, dry, ventilated area. Protect against physical damage. Isolate from any source of heat or ignition. Do not use or store on porous work surfaces (wood, unsealed concrete, etc.). Follow strict hygiene practices. Containers of this material may be hazardous when empty since they retain product residues (vapors, liquid); observe all warnings and precautions listed for the product.

8. EXPOSURE CONTROLS/PERSONAL PROTECTION

Airborne Exposure Limits:

- OSHA Acceptable Ceiling Concentration:

mercury and mercury compounds: 0.1 mg/m³ (TWA), skin

- ACGIH Threshold Limit Value (TLV):

inorganic and metallic mercury, as Hg: 0.025 mg/m³ (TWA) skin, A4 Not classifiable as a human carcinogen.

- ACGIH Biological Exposure Indices:

total inorganic mercury in urine (preshift): 35 ug/g creatinine;

total inorganic mercury in blood (end of shift): 15 ug/l.

Ventilation System:

A system of local and/or general exhaust is recommended to keep employee exposures below the Airborne Exposure Limits. Local exhaust ventilation is generally preferred because it can control the emissions of the contaminant at its source, preventing dispersion of it into the general work area. Please refer to the ACGIH document, *Industrial Ventilation, A Manual of Recommended Practices*, most recent edition, for details.

Personal Respirators (NIOSH Approved):

If the exposure limit is exceeded, a half-face respirator with a mercury vapor or chlorine gas cartridge may be worn for up to ten times the exposure limit or the maximum use concentration specified by the appropriate regulatory agency or respirator supplier, whichever is lowest. A full-face piece respirator with a mercury vapor or chlorine gas cartridge may be worn up to 50 times the exposure limit, or the maximum use concentration specified by the appropriate regulatory agency or respirator supplier, whichever is lowest. For emergencies or instances where the exposure levels are not known, use a full-face piece positive-pressure, air-supplied respirator. WARNING: Air-purifying respirators do not protect workers in oxygen-deficient atmospheres.

Skin Protection:

Wear impervious protective clothing, including boots, gloves, lab coat, apron or coveralls, as appropriate, to prevent skin contact.

Eye Protection:

Use chemical safety goggles and/or a full face shield where splashing is possible. Maintain eye wash fountain and quick-drench facilities in work area.

9. PHYSICAL AND CHEMICAL PROPERTIES

Appearance:

Silver-white, heavy, mobile, liquid metal.

Odor:

Odorless.

Solubility:

Insoluble in water.

Density:

13.55

pH:

No information found.

% Volatiles by volume @ 21C (70F):

100

Boiling Point:

356.7C (675F)

Melting Point:

-38.87C (-38F)

Vapor Density (Air=1):

7.0

Vapor Pressure (mm Hg):

0.0018 @ 25C (77F)

Evaporation Rate (BuAc=1):

4

10. STABILITY AND REACTIVITY

Stability:

Stable under ordinary conditions of use and storage.

Hazardous Decomposition Products:

At high temperatures, vaporizes to form extremely toxic fumes.

Hazardous Polymerization:

Will not occur.

Incompatibilities:

Acetylenes, ammonia, ethylene oxide, chlorine dioxide, azides, metal oxides, methyl silane, lithium, rubidium, oxygen, strong oxidants, metal carbonyls.

Conditions to Avoid:

Heat, flames, ignition sources, metal surfaces and incompatibles.

11. TOXICOLOGICAL INFORMATION

Toxicological Data:

Investigated as a tumorigen, mutagen, reproductive effector.

Reproductive Toxicity:

All forms of mercury can cross the placenta to the fetus, but most of what is known has been learned from experimental animals. See Chronic Health Hazards.

Carcinogenicity:

EPA / IRIS classification: Group D1 - Not classifiable as a human carcinogen.

-----\Cancer Lists\-----			
Ingredient	---NTP Carcinogen---		IARC Category
	Known	Anticipated	
Mercury (7439-97-6)	No	No	3

12. ECOLOGICAL INFORMATION

Environmental Fate:

This material has an experimentally-determined bioconcentration factor (BCF) of greater than 100. This material is expected to significantly bioaccumulate.

Environmental Toxicity:

This material is expected to be toxic to aquatic life. The LC50/96-hour values for fish are less than 1 mg/l.

13. DISPOSAL CONSIDERATIONS

Whatever cannot be saved for recovery or recycling should be handled as hazardous waste and sent to a RCRA approved waste facility. Processing, use or contamination of this product may change the waste management options. State and local disposal regulations may differ from federal disposal regulations. Dispose of container and unused contents in accordance with federal, state and local requirements.

14. TRANSPORT INFORMATION

Domestic (Land, D.O.T.)

Proper Shipping Name: RQ, MERCURY

Hazard Class: 8

UN/NA: UN2809

Packing Group: III

Information reported for product/size: 2.5KG

Thoreson-McCosh Inc

International (Water, I.M.O.)

Proper Shipping Name: MERCURY
Hazard Class: 8
UN/NA: UN2809
Packing Group: III
Information reported for product/size: 2.5KG

International (Air, I.C.A.O.)

Proper Shipping Name: MERCURY
Hazard Class: 8
UN/NA: UN2809
Packing Group: III
Information reported for product/size: 2.5KG

15. REGULATORY INFORMATION

-----\Chemical Inventory Status - Part 1\-----
Ingredient TSCA EC Japan Australia

Mercury (7439-97-6) Yes Yes No Yes

-----\Chemical Inventory Status - Part 2\-----
Ingredient Korea DSL NDSL Phil.

Mercury (7439-97-6) Yes Yes No Yes

-----\Federal, State & International Regulations - Part 1\-----
-SARA 302- -SARA 313-----
Ingredient RQ TPQ List Chemical Catg.

Mercury (7439-97-6) No No Yes No

-----\Federal, State & International Regulations - Part 2\-----
Ingredient CERCLA -RCRA- -TSCA-

Mercury (7439-97-6) 1 U151 No

Chemical Weapons Convention: No TSCA 12(b): No CDTA: No
SARA 311/312: Acute: Yes Chronic: Yes Fire: No Pressure: No
Reactivity: No (Pure / Liquid)

WARNING:

THIS PRODUCT CONTAINS A CHEMICAL(S) KNOWN TO THE STATE OF CALIFORNIA TO CAUSE BIRTH DEFECTS OR OTHER REPRODUCTIVE HARM.

Australian Hazchem Code: 2Z

Thoreson-McCosh Inc

Poison Schedule: S7

WHMIS:

This MSDS has been prepared according to the hazard criteria of the Controlled Products Regulations (CPR) and the MSDS contains all of the information required by the CPR.

16. OTHER INFORMATION

NFPA Ratings: Health: **3** Flammability: **0** Reactivity: **0**

Label Hazard Warning:

DANGER! CORROSIVE. CAUSES BURNS TO SKIN, EYES, AND RESPIRATORY TRACT. MAY BE FATAL IF SWALLOWED OR INHALED. HARMFUL IF ABSORBED THROUGH SKIN. AFFECTS THE KIDNEYS AND CENTRAL NERVOUS SYSTEM. MAY CAUSE ALLERGIC SKIN REACTION.

Label Precautions:

- Do not get in eyes, on skin, or on clothing.
- Do not breathe vapor.
- Keep container closed.
- Use only with adequate ventilation.
- Wash thoroughly after handling.

Label First Aid:

If swallowed, induce vomiting immediately as directed by medical personnel. Never give anything by mouth to an unconscious person. If inhaled, remove to fresh air. If not breathing, give artificial respiration. If breathing is difficult, give oxygen. In case of contact, immediately flush eyes or skin with plenty of water for at least 15 minutes while removing contaminated clothing and shoes. Wash clothing before reuse. In all cases get medical attention immediately.

Product Use:

Laboratory Reagent.

Revision Information:

No changes.

Disclaimer:

Mallinckrodt Baker, Inc. provides the information contained herein in good faith but makes no representation as to its comprehensiveness or accuracy. This document is intended only as a guide to the appropriate precautionary handling of the material by a properly trained person using this product. Individuals receiving the information must exercise their independent judgment in determining its appropriateness for a particular purpose. MALLINCKRODT BAKER, INC. MAKES NO REPRESENTATIONS OR WARRANTIES, EITHER EXPRESS OR IMPLIED, INCLUDING WITHOUT LIMITATION ANY WARRANTIES OF MERCHANTABILITY, FITNESS FOR A PARTICULAR PURPOSE WITH RESPECT TO THE INFORMATION SET FORTH HEREIN OR THE PRODUCT TO WHICH THE INFORMATION REFERS. ACCORDINGLY, MALLINCKRODT BAKER, INC. WILL NOT BE RESPONSIBLE

Thoreson-McCosh Inc

**FOR DAMAGES RESULTING FROM USE OF OR RELIANCE UPON THIS
INFORMATION.**

Prepared by: Strategic Services Division
Phone Number: (314) 539-1600 (U.S.A.)

