

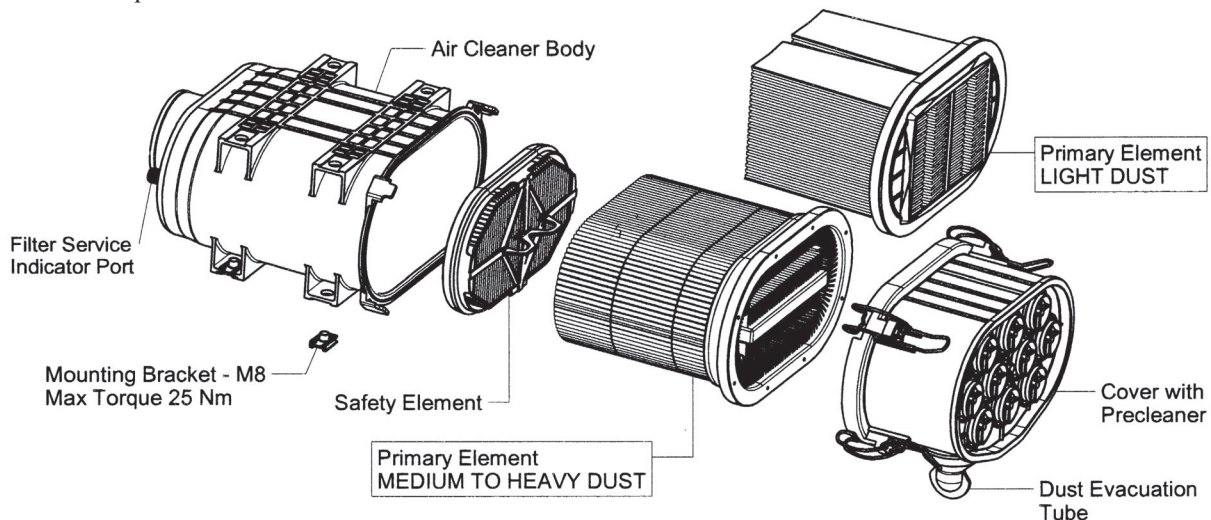

Secondo la filosofia " Più piccolo è Meglio ", **Virgis Filter** ha progettato un nuovo Sistema Filtro che fornisce la soluzione a tutti i produttori che oggi devono confrontarsi con motori che richiedono maggiori prestazioni, una nuova legislazione sulle emissioni, maggior consumo d'aria e meno spazio disponibile nel vano motore. Questo nuovo concetto consente di usare un filtro aria più piccolo con le stesse prestazioni di uno convenzionale.

Using the philosophy " Smaller is Better ", **Virgis Filter** have designed a new Air Cleaner System that provides a solutions for the problem that all manufactures face today with engines demanding greater performance, new emission legislation, more air consumption and less available engine compartment space. This new concept enables the O.E. to use small Air Cleaner, which achieves the same performance as a conventional Air Cleaner.



Vantaggi :

- Più compatto di un filtro convenzionale a parità di prestazioni, riduce lo spazio di installazione
- Flusso d'aria assiale e staffe di montaggio integrate
- Varie possibilità di installazione
- Coperchio prefiltra con separazione fino al 95%, vita del filtro più lunga
- Temperature di esercizio da - 35 °C a + 85 °C con punte di + 100 °C

Advantage :

- More compact at a given performance level than a conventional filter, reduced installation space
- Axial air flow and integrated mounting brackets
- Various possibilities of installation
- Precleaner cover with a separation up to 95%, longer filter service life
- Working temperature - 35 °C a + 85 °C with peaks + 100 °C

SCAVENGE (ASPIRAZIONE) !

Si ottiene aspirando dal tubo di scarico del coperchio prefiltra (ad esempio collegando alla marmitta un eiettore). In questo modo il contaminante viene espulso dal sistema di scarico.

Jokto è progettato per funzionare con o senza pulizia. I principali vantaggi della modalità di evacuazione sono:

- Vita del filtro più lunga grazie alla maggiore efficienza della prefiltrazione
- Il tubo scarico polveri può essere posizionato secondo qualsiasi orientamento
- Nessuna manutenzione del coperchio prefiltra (se con valvola evacuatrice e in condizioni gravose può essere facilmente pulito)

TO SCAVENGE IS BETTER !

Scavenging is obtained by introducing a secondary flow (connecting for example to the ejector muffler) to the drop tube on the multi-cyclone block. In this way the contaminant is sucked into the exhaust stream.

Jokto is designed to operate with or without scavenging. The main advances of scavenging mode are:

- Longer filter life service, resulting with higher pre-cleaner efficiency
- Drop tube not just straight down but it can be located in various orientations
- No servicing required (if installed only with evacuator valve and if heavy duty condition occur, can be easily serviced)

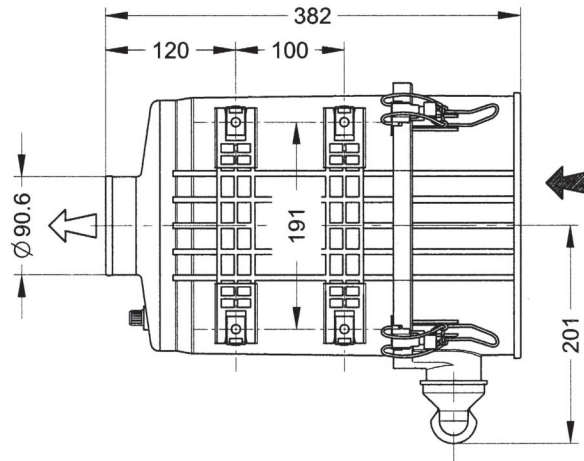
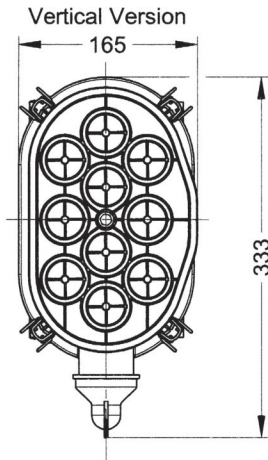
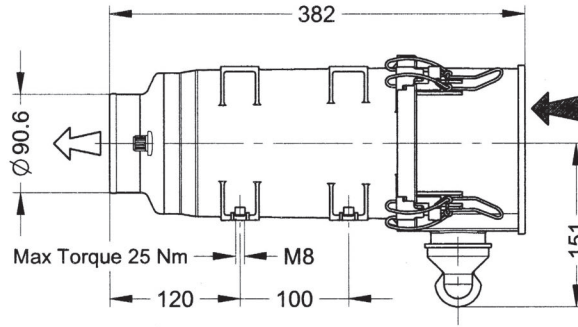
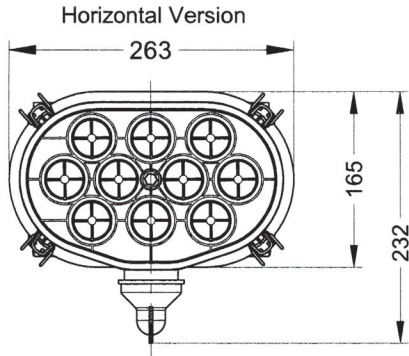

TIPO - TYPE	FILTRO ARIA AIR CLEANER	PORTATA ARIA AIR FLOW	PRIMARIA MAIN	SICUREZZA SAFETY
	Codice-Code	m ³ /min	Codice-Code	
Medium to Heavy Dust (H)	FJ08-18065-C0	6	18056	18073
Medium to Heavy Dust (V)	FJ08-18070-C0	6	18056	18073
Light Dust (H)	FJ08-18561-C0	6.2	18560	18073
Light Dust (H)	FJ08-18562-C0	6.2	18560	18073

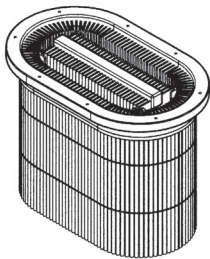

PRIMARY ELEMENT
 MEDIUM TO HEAVY DUST

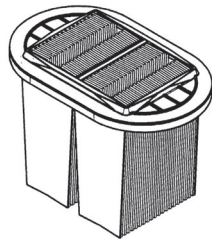

PRIMARY ELEMENT
 LIGHT DUST

