

AMCO CASTLE LANTERN- BASE TYPE FOR GATE AND FENCE

AVAILABLE IN WRINKLE BLACK AND COPPER ANTIQUE COLOR, WITH SOCKET WITHOUT BULB

MODEL NO. AP-1003LR	MODEL NO. AP-1103-LMX	MODEL NO. AP-1003L	MODEL NO. AP-1103LM	MODEL NO. AP-1103LEP
MODEL NO. AP-1003RES	MODEL NO. AP-1103ESX	MODEL NO. AP-1003ES	MODEL NO. AP-1103ES	MODEL NO. AP-1103ESP
MODEL NO. C-2T	MODEL NO. AP-1003WP	MODEL NO. AP-1003LB	MODEL NO. AP-1103SP	
MODEL NO. C-3T	MODEL NO. AP-1003W	MODEL NO. AP-1003	MODEL NO. AP-1103-S	













AMCO CASTLE LANTERN- BASE TYPE & COUPLING TYPE FOR GI POST 1½" OR 2"Ø

AVAILABLE IN WRINKLE BLACK AND COPPER ANTIQUE COLOR, WITH SOCKET WITHOUT BULB

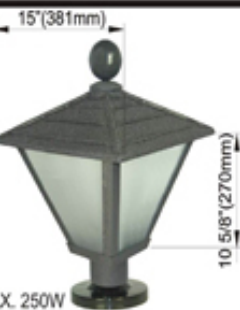
 8½" (215.9mm) 7½" (190.5mm) 6 ¾" (171.45mm) MAX. 60W	 8 ¾"(222.25mm) 7½" (190.5mm) MAX. 60W	 9½"(241.3mm) 7½" (190.5mm) MAX. 60W	 8 ¾"(222.25mm) 7½" (190.5mm) MAX. 60W	 8 ¾"(222.25mm) 7½" (190.5mm) MAX. 60W
MODEL NO. C-8LES	MODEL NO. AP-1103-LMX-C	MODEL NO. AP-1003L-C	MODEL NO. AP-1103LM-C	MODEL NO. AP-1103LEP-C
 8½" (215.9mm) 6 ¾" (171.45mm) 5" (127mm) MAX. 60W	 8 ¾"(222.25mm) 5" (127mm) MAX. 60W	 9½"(241mm) 5" (127mm) MAX. 60W	 8 ¾"(222.25mm) 5" (127mm) MAX. 60W	 8 ¾"(222.25mm) 5" (127mm) MAX. 60W
MODEL NO. C-7ES	MODEL NO. AP-1103ESX-C	MODEL NO. AP-1003ES-C	MODEL NO. AP-1103ES-C	MODEL NO. AP-1103ESP-C
 15 3/8"(390.5mm) 8 7/8" (225.425mm) MAX. 160W	 11½"(292.1mm) 5½" (139.7mm) MAX. 100W	 11½"(292.1mm) 9 ½" (241.3mm) MAX. 160W	 12"(304.8mm) 8½" (215.9mm) MAX. 160W	
MODEL NO. C-2T-C	MODEL NO. AP-1003WP-C	MODEL NO. AP-1003LB-C	MODEL NO. AP-1103SP-C	
 15 3/8"(390.5mm) 6" (152.4mm) MAX. 160W	 11½"(292.1mm) 5½" (139.7mm) MAX. 100W	 11½"(292.1mm) 5½" (139.7mm) MAX. 100W	 12"(304.8mm) 8½" (215.9mm) MAX. 160W	
MODEL NO. C-3T-C	MODEL NO. AP-1003W-C	MODEL NO. AP-1003-C	MODEL NO. AP-1103S-C	















AMCO CASTLE LANTERN- BASE TYPE & COUPLING TYPE FOR GI POST

AVAILABLE IN WRINKLE BLACK AND COPPER ANTIQUE COLOR, WITH SOCKET WITHOUT BULB

 <p>12 1/2" (317.5mm)</p> <p>9 1/2" (241.3mm)</p> <p>9 1/8" (231.8mm)</p> <p>MAX. 100W</p>	 <p>12 1/8" (308mm)</p> <p>6 3/4" (171.4mm)</p>	 <p>12 1/8" (308mm)</p> <p>6 3/4" (171.4mm)</p>	 <p>12 1/2" (317.5mm)</p> <p>9 1/2" (241.3mm)</p> <p>9 1/8" (231.8mm)</p> <p>MAX. 100W</p>
	<p>MODEL NO.</p> <p>AP-1003R</p>	<p>MODEL NO.</p> <p>AP-1003R-C</p>	
<p>MODEL NO.</p> <p>C-8L</p>	 <p>12 1/2" (317.5mm)</p> <p>9 1/2" (241.3mm)</p> <p>6" (152.4mm)</p> <p>MAX. 100W</p>	 <p>12 1/2" (317.5mm)</p> <p>9 1/2" (241.3mm)</p> <p>6" (152.4mm)</p> <p>MAX. 100W</p>	<p>MODEL NO.</p> <p>C-8L-C</p>
	<p>MODEL NO.</p> <p>C-7M</p>	<p>MODEL NO.</p> <p>C-7M-C</p>	
 <p>18" (457.2mm)</p> <p>12 5/8" (320.67mm)</p> <p>MAX. 250W</p>	 <p>15" (381mm)</p> <p>10 5/8" (270mm)</p> <p>MAX. 250W</p>	 <p>15" (381mm)</p> <p>10 5/8" (270mm)</p> <p>MAX. 250W</p>	 <p>18" (457.2mm)</p> <p>12 5/8" (320.67mm)</p> <p>MAX. 250W</p>
	<p>MODEL NO.</p> <p>AP-1103L</p>	<p>MODEL NO.</p> <p>AP-1103M</p>	
 <p>18" (457.2mm)</p> <p>12 5/8" (320.67mm)</p> <p>MAX. 250W</p>	 <p>15" (381mm)</p> <p>10 5/8" (152.4mm)</p> <p>MAX. 250W</p>	 <p>15" (381mm)</p> <p>10 5/8" (152.4mm)</p> <p>MAX. 250W</p>	 <p>18" (457.2mm)</p> <p>12 5/8" (320.67mm)</p> <p>MAX. 250W</p>
	<p>MODEL NO.</p> <p>AP-1103LP</p>	<p>MODEL NO.</p> <p>AP-1103MP</p>	
	<p>MODEL NO.</p> <p>AP-1103LP-C</p>		

AMCO CASTLE LANTERN- HANGING TYPE WITH CHAIN 18"

AVAILABLE IN WRINKLE BLACK AND COPPER ANTIQUE COLOR, WITH SOCKET WITHOUT BULB

 MAX. 100W	 MAX. 100W	 MAX. 100W	 MAX. 160W	 MAX. 160W
MODEL NO. AP-1005WP	MODEL NO. AP-1005W	MODEL NO. AP-1005	MODEL NO. AP-1005LB	MODEL NO. AP-1005R
 MAX. 60W	 MAX. 60W	 MAX. 60W	 MAX. 60W	 MAX. 60W
MODEL NO. AP-1105LX	MODEL NO. AP-1105LP	MODEL NO. AP-1105L	MODEL NO. AP-1005L	MODEL NO. AP-1005LR
 MAX. 60W	 MAX. 60W	 MAX. 60W	 MAX. 60W	 MAX. 60W
MODEL NO. AP-1105ESX	MODEL NO. AP-1105ESP	MODEL NO. AP-1105ES	MODEL NO. AP-1005ES	MODEL NO. AP-1005RES

AMCO CASTLE LANTERN- WALL TYPE AND COUPLING TYPE

AVAILABLE IN WRINKLE BLACK AND COPPER ANTIQUE COLOR, WITH SOCKET WITHOUT BULB

<p>8 1/2" 7 1/8" MAX. 60W</p>	<p>8 1/2" 6 3/4" 7 1/2" MAX. 60W</p>	<p>11 1/2" 9" MAX. 160W</p>	<p>11 1/2" 9" MAX. 160W</p>
MODEL NO. AP-1003LR-C	MODEL NO. C-8LES-C (Black/Antique)	MODEL NO. AP-1004LB	MODEL NO. AP-1006LB
<p>8 1/2" 5" MAX. 60W</p>	<p>8 1/2" 6 3/4" 5 1/2" MAX. 60W</p>	<p>11 1/2" 6 1/8" MAX. 100W</p>	<p>11 1/2" 6 1/8" MAX. 100W</p>
MODEL NO. AP-1003-RES-C	MODEL NO. C7-ES-C (Black/Antique)	MODEL NO. AP-1004	MODEL NO. AP-1006
<p>12 1/2" 9 1/2" 9 1/8" MAX. 100W</p>	<p>11 1/2" 5 1/2" MAX. 100W</p>	<p>11 1/2" 5 1/2" 8 1/2" MAX. 100W</p>	<p>12 1/8" 6 3/4" MAX. 160W</p>
MODEL NO. C-8W (Black/Antique)	MODEL NO. AP-1006WP	MODEL NO. AP-1004WP	MODEL NO. AP-1004R
<p>12 1/2" 9 1/2" 6" MAX. 100W</p>	<p>11 1/2" 5 1/2" MAX. 100W</p>	<p>11 1/2" 5 1/2" 8 1/2" MAX. 100W</p>	<p>12 1/8" 6 3/4" MAX. 160W</p>
MODEL NO. C-7W (Black/Antique)	MODEL NO. AP-1006W	MODEL NO. AP-1004W	MODEL NO. AP-1006R

AMCO CASTLE LANTERN- WALL TYPE

AVAILABLE IN WRINKLE BLACK AND COPPER ANTIQUE COLOR, WITH SOCKET WITHOUT BULB

 <p>MAX. 60W</p>	 <p>MAX. 60W</p>	 <p>MAX. 60W</p>	
MODEL NO. AP-1106LP	MODEL NO. AP-1106L	MODEL NO. C-8WL (Black/Antique)	MODEL NO. 2-A
 <p>MAX. 60W</p>	 <p>MAX. 60W</p>	 <p>MAX. 60W</p>	
MODEL NO. AP-1106ESP	MODEL NO. AP-1106ES	MODEL NO. C-7WES (Black/Antique)	MODEL NO. 1-A
 <p>MAX. 60W</p>	 <p>MAX. 60W</p>	 <p>MAX. 60W</p>	
MODEL NO. AP-1006L	MODEL NO. AP-1006LR	MODEL NO. AP-1106LX	MODEL NO. X-2
 <p>MAX. 60W</p>	 <p>MAX. 60W</p>	 <p>MAX. 60W</p>	
MODEL NO. AP-1006ES	MODEL NO. AP-1006RES	MODEL NO. AP-1106ESX	MODEL NO. X-1

AMCO CASTLE LANTERN- WALL TYPE WITH DIE-CAST ALUMINUM BRACKET

AVAILABLE IN WRINKLE BLACK AND COPPER ANTIQUE COLOR, WITH SOCKET WITHOUT BULB

<p>MODEL NO. AP-1006ES-1A</p>	<p>MODEL NO. AP-1006-1A</p>	<p>MODEL NO. AP-1006RES-1A</p>	<p>MODEL NO. AP-1006LR-1A</p>
<p>MODEL NO. AP-1007-W-1A</p>	<p>MODEL NO. AP-1106ES-1A</p>	<p>MODEL NO. AP-1106L-1A</p>	<p>MODEL NO. AP-1006L-1A</p>
<p>MODEL NO. AP-1006-GS-1A</p>	<p>MODEL NO. C-8WES-1A</p>	<p>MODEL NO. AP-1106ESP-1A</p>	<p>MODEL NO. AP-1106LP-1A</p>
	<p>MODEL NO. C-8WES-1A</p>	<p>MODEL NO. AP-1106ESP-1A</p>	<p>MODEL NO. AP-1106LP-1A</p>
<p>MODEL NO. C-7WES-1A</p>	<p>MODEL NO. C-8WES-1A</p>	<p>MODEL NO. AP-1106ESP-1A</p>	<p>MODEL NO. AP-1106LP-1A</p>

AMCO CASTLE LANTERN- WALL TYPE WITH DIE-CAST ALUMINUM BRACKET





AVAILABLE IN WRINKLE BLACK AND COPPER ANTIQUE COLOR, WITH SOCKET WITHOUT BULB



<p>MODEL NO. AP-1106ES-2A</p>	<p>MODEL NO. AP-1106L-2A</p>	<p>MODEL NO. C-7WES-2A</p>
<p>MODEL NO. AP-1106LP-2A</p>	<p>MODEL NO. AP-1106ESP-2A</p>	<p>MODEL NO. C-8WES-2A</p>
<p>MODEL NO. AP-1006RES-2A</p>	<p>MODEL NO. AP-1006ES-2A</p>	<p>MODEL NO. AP-1007-W-2A</p>
<p>MODEL NO. AP-1006LR-2A</p>	<p>MODEL NO. AP-1006L-2A</p>	<p>MODEL NO. AP-1006-GS-2A</p>

AMCO ANTIQUE LAMP POST WITH CASTLE LANTERN AND ACCESSORIES

MODEL NO. 1 - B		MODEL NO. 1 - BP			
W A L L T Y P E			W A L L T Y P E		
	MODEL NO. C4 - CW			MODEL NO. C4 - SW	
P O S T T Y P E			G A T E T Y P E		
	MODEL NO. C4 - SC			MODEL NO. C4 - SM	
CASTLE LANTERN WITH DECORATIVE POST AND BASE					
MODEL NO. C-145SC		MODEL NO. C-141SCX		MODEL NO. C-143SC	
MODEL NO. C-144SC		MODEL NO. C-141SC		MODEL NO. C-142SC	

AMCO CASTLE LANTERN

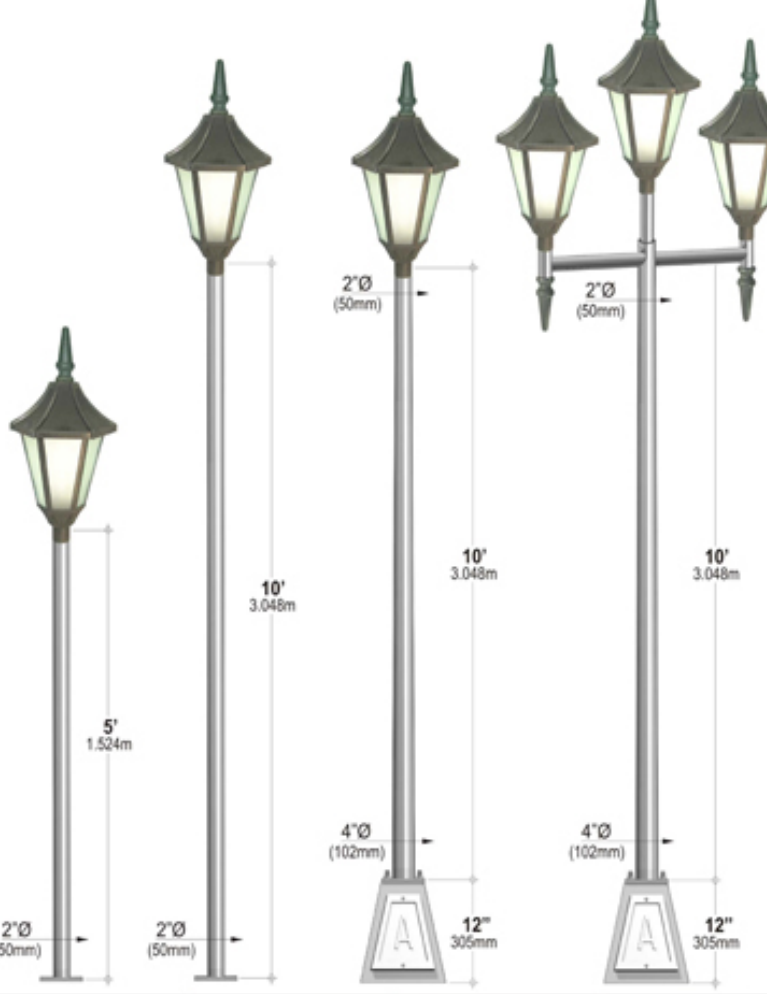
 <p>COUPLING TYPE</p>	<p>WALL TYPE</p> 	 <p>WALL TYPE</p>	<p>BASE TYPE</p> 
<p>MODEL NO. C4 - SC</p>	<p>MODEL NO. C4 - SW</p>	<p>MODEL NO. C4 - CW</p>	<p>MODEL NO. C4 - SM</p>

 <p>MODEL NO. C4 - SP - 2L</p>	 <p>Dimensions shown: Pole heights: 5' (1.524m), 10' (3.048m), 10' (3.048m), 10' (3.048m) Pole diameters: 2" (50mm), 2" (50mm), 4" (102mm), 4" (102mm) Base diameters: 12" (305mm), 12" (305mm)</p>			
<p>DIMENSION:</p>  <p>Labels: Fiber Glass Pine Metal Cover Metal Frame Socket Bulb Industrix Glass or Prismatic Acrylic Plastic 2" G.I. Pipe Coupling</p> <p>Dimensions: MAX. 250W 18" 7 7/8" (200mm) 6 1/2" (165mm) 28 7/8" (733mm) 11 1/2" (292mm) 3" (76mm) 2" (50mm)</p>	<p>MODEL NO. C4 - SP - 5</p>	<p>MODEL NO. C4 - SP - 10</p>	<p>MODEL NO. C4 - TP - 1L</p>	<p>MODEL NO. C4 - SP - 3L</p>

AMCO CASTLE LANTERN

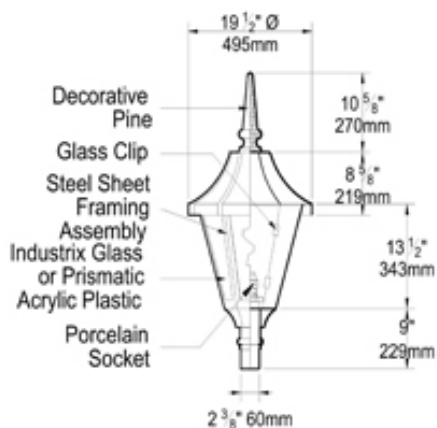

MODEL NO.
C-9

MODEL NO.
C-9D

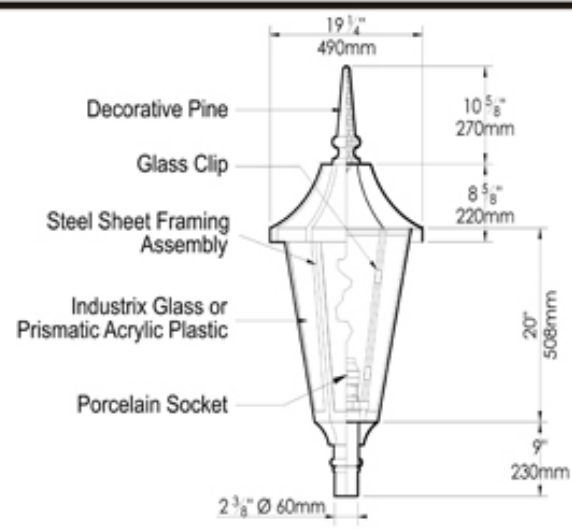
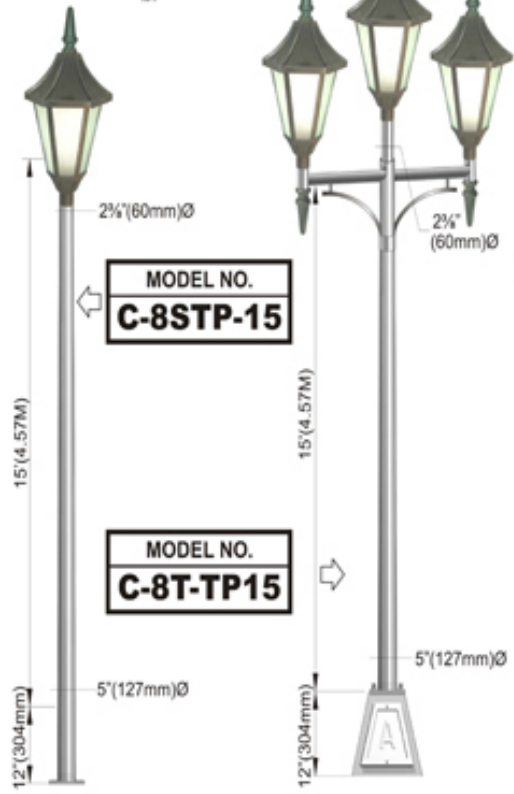
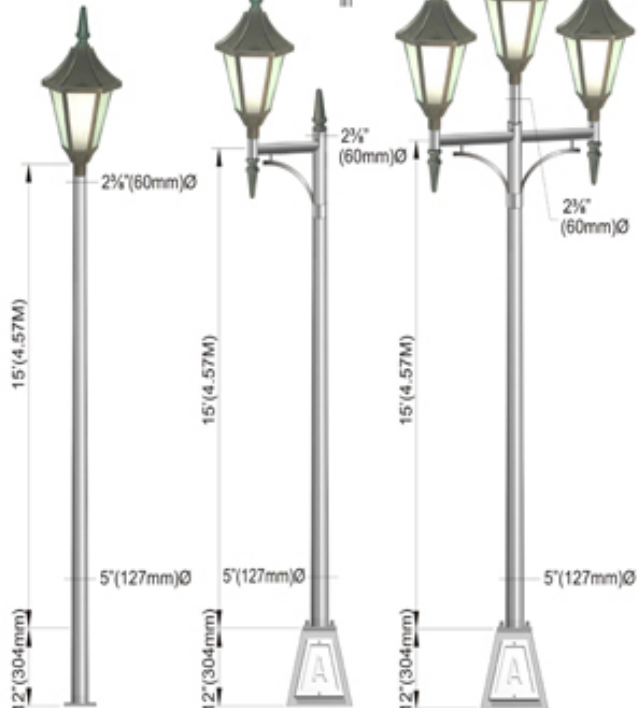
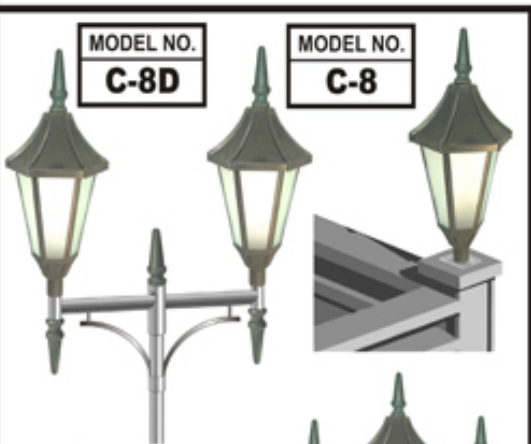

AMCO CASTLE LANTERN



MODEL NO.

C - 25B



MODEL NO.

C - 25SC



MODEL NO.

C - 30W



MODEL NO.

C - 30P2

DESCRIPTION:

CASTLE LANTERN: Metal sheet housing is available in antique powder coating finish or wrinkle black enamel paint finishes.

POST: Zinc electro-galvanized steel lamp post and pedestal base coated with red oxide and enamel paint finish. Complete with anchor bolts, bolts, nuts and washers. Available in enamel black paint finish, antique powder coating finish and wrinkle black baking enamel paint finish.

Wattage:

Ballast Type 50w-125w
None Ballast 160w-250w

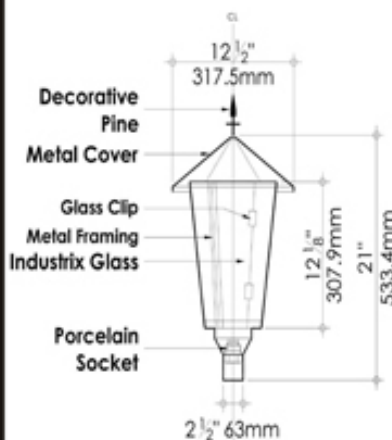

DIMENSIONS:



MODEL NO.

C30 - SP - 5



MODEL NO.

C30 - SP - 10







MODEL NO.

C30-SP-10-3

AMCO ANTIQUE LAMP POST WITH CASTLE LANTERN AND ACCESSORIES

MODEL NO. 1 - B		MODEL NO. 1 - BP			
W A L L T T P E	W A L L T T P E	P O S T T T P E	G A T E T T P E		
MODEL NO. C4 - CW		MODEL NO. C4 - SW		MODEL NO. C4 - SC	
				MODEL NO. C4 - SM	
CASTLE LANTERN WITH DECORATIVE POST AND BASE					
MODEL NO. C-145SC		MODEL NO. C-141SCX		MODEL NO. C-143SC	
MODEL NO. C-144SC		MODEL NO. C-141SC		MODEL NO. C-142SC	

AMCO CASTLE LANTERN

 <p>COUPLING TYPE</p>	<p>WALL TYPE</p> 	 <p>WALL TYPE</p>	<p>BASE TYPE</p> 
<p>MODEL NO. C4 - SC</p>	<p>MODEL NO. C4 - SW</p>	<p>MODEL NO. C4 - CW</p>	<p>MODEL NO. C4 - SM</p>

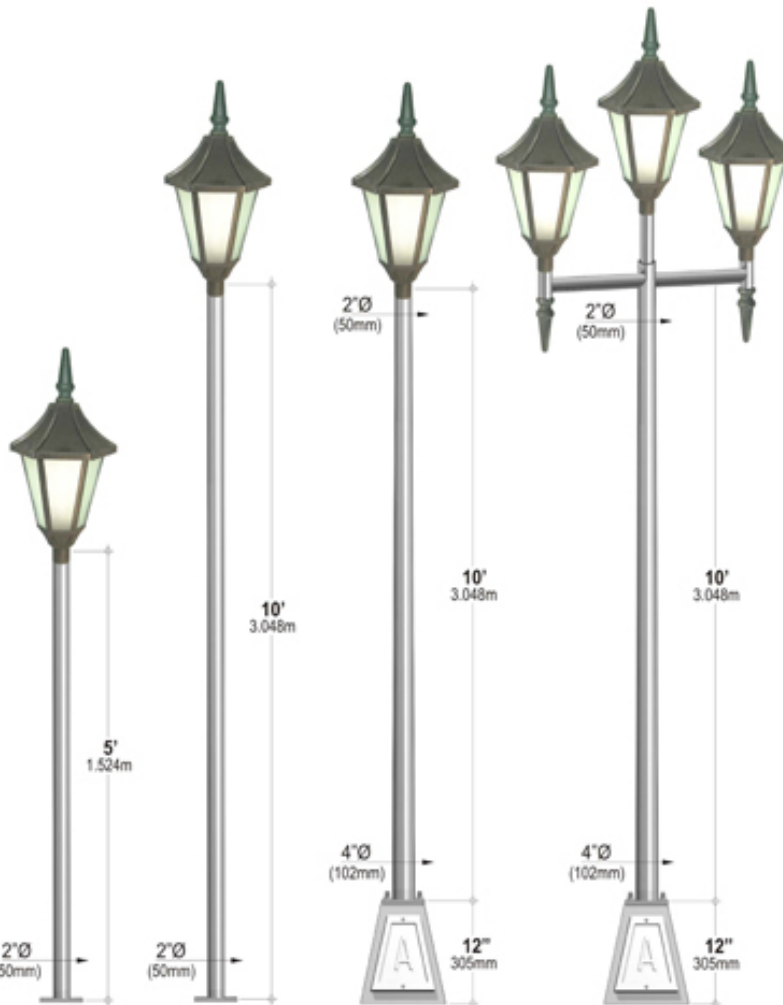
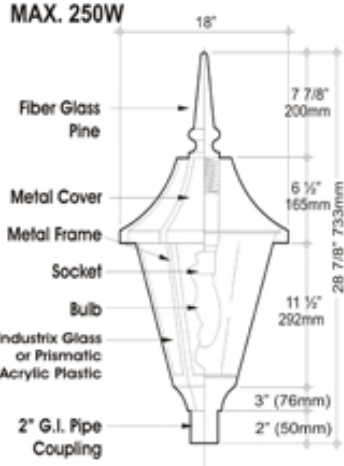
 <p>MODEL NO. C4 - SP - 2L</p>	 <p>Dimensions shown: - Pole 1: 5' (1.524m) height, 2" (50mm) diameter. - Pole 2: 10' (3.048m) height, 2" (50mm) diameter. - Pole 3: 10' (3.048m) height, 4" (102mm) diameter. - Pole 4: 10' (3.048m) height, 4" (102mm) diameter. - Pole 5: 12" (305mm) height, 4" (102mm) diameter. - Pole 6: 12" (305mm) height, 4" (102mm) diameter.</p>			
<p>DIMENSION:</p>  <p>Labels: - Fiber Glass Pine - Metal Cover - Metal Frame - Socket - Bulb - Industrix Glass or Prismatic Acrylic Plastic - 2" G.I. Pipe Coupling</p> <p>Dimensions: - Max. 250W - 18" (width) - 7 7/8" (200mm) (height) - 6 1/2" (165mm) (height) - 28 7/8" (733mm) (height) - 11 1/2" (292mm) (height) - 3" (76mm) (width) - 2" (50mm) (width)</p>	<p>MODEL NO. C4 - SP - 5</p>	<p>MODEL NO. C4 - SP - 10</p>	<p>MODEL NO. C4 - TP - 1L</p>	<p>MODEL NO. C4 - SP - 3L</p>

AMCO CASTLE LANTERN

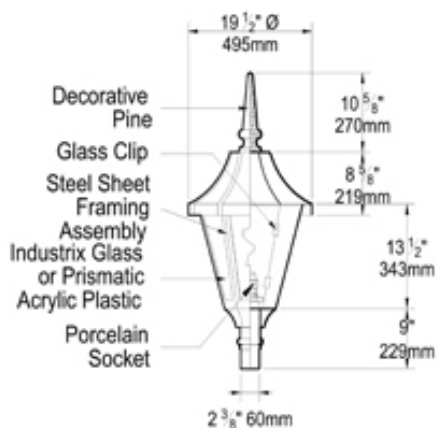

MODEL NO.
C-9

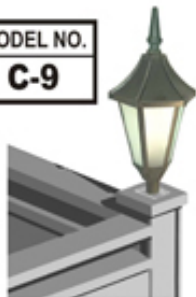

MODEL NO.
C-9D

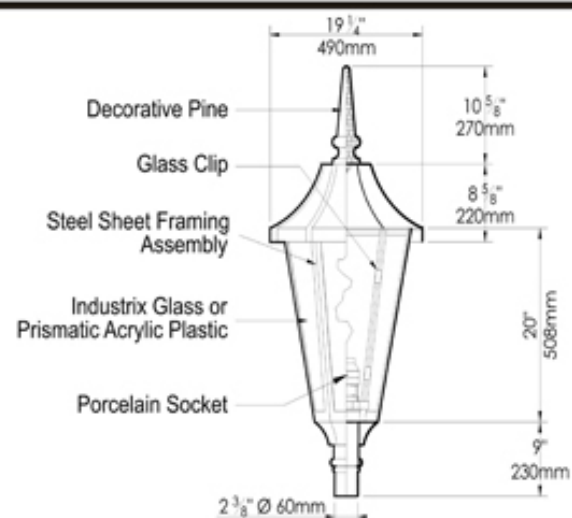
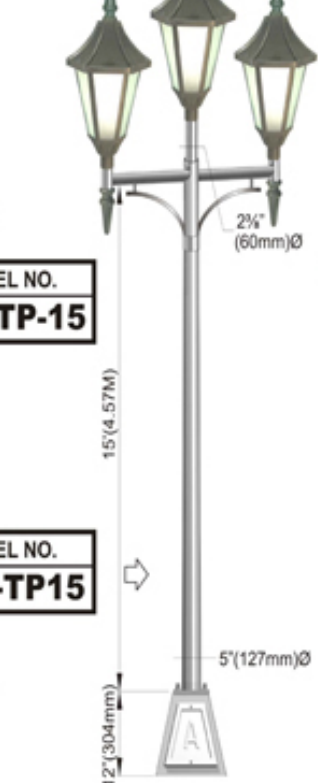
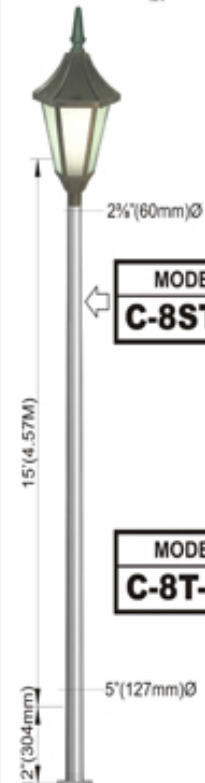
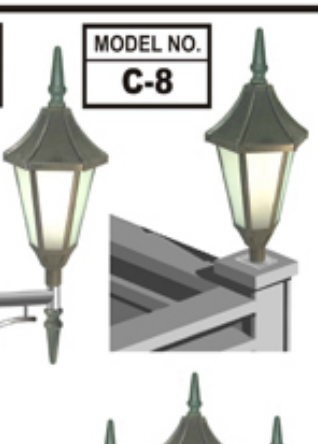

AMCO CASTLE LANTERN



MODEL NO.

C - 25B



MODEL NO.

C - 25SC



MODEL NO.

C - 30W



MODEL NO.

C - 30P2

DESCRIPTION:

CASTLE LANTERN: Metal sheet housing is available in antique powder coating finish or wrinkle black enamel paint finishes.

POST: Zinc electro-galvanized steel lamp post and pedestal base coated with red oxide and enamel paint finish. Complete with anchor bolts, bolts, nuts and washers. Available in enamel black paint finish, antique powder coating finish and wrinkle black baking enamel paint finish.

Wattage:

Ballast Type 50w-125w
None Ballast 160w-250w

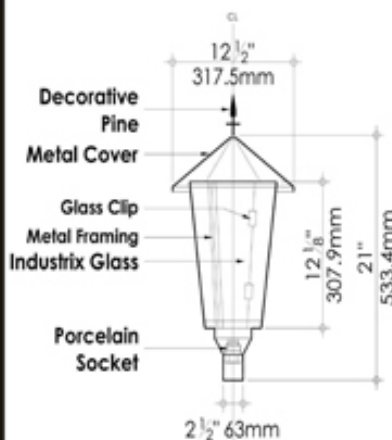

DIMENSIONS:



MODEL NO.

C30 - SP - 5



MODEL NO.

C30 - SP - 10



MODEL NO.

C30-SP-10-3

AMCO CASTLE LANTERN

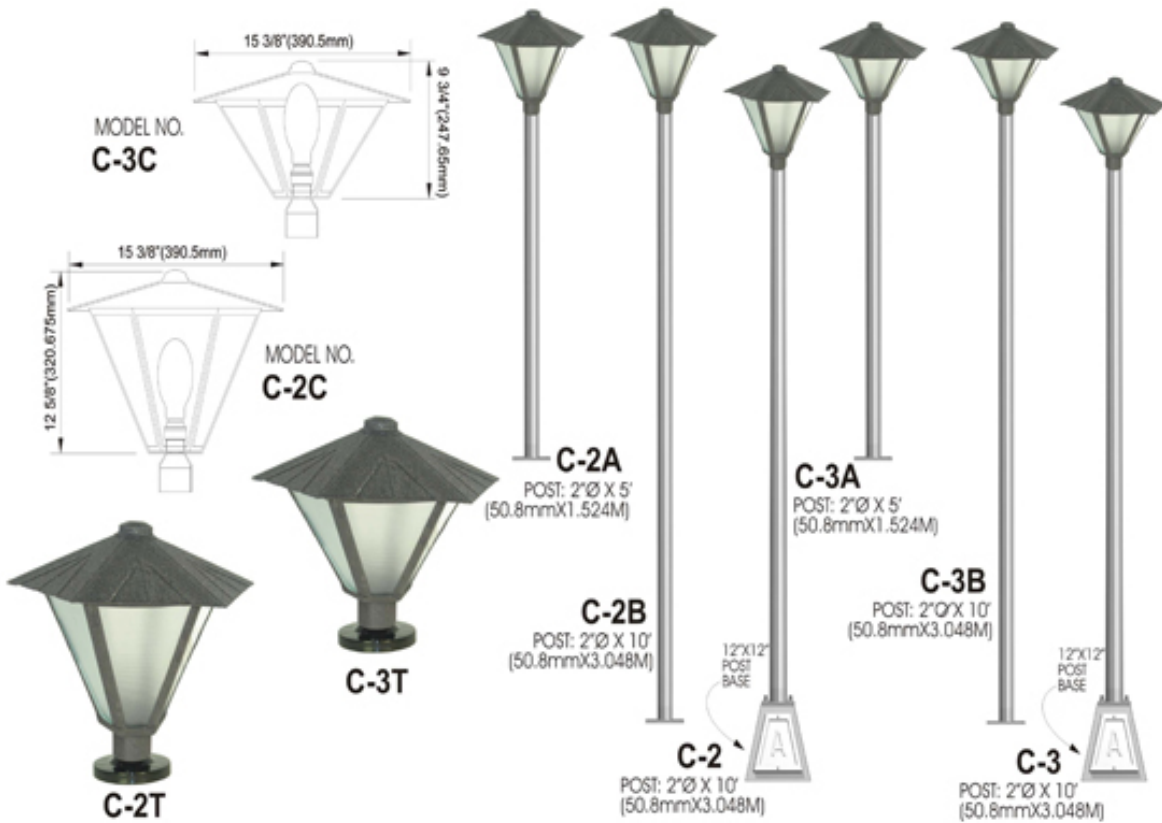

AMCO URBAN LAMP SHADE TYPE

