

NOTES:

1 GENERAL NOTES

1.1 THIS DRAWING HAS BEEN PROVIDED TO R U GROUNDED ENERGY INC.. USE OF THIS DRAWING BY ANY OTHER COMPANY OR ENTITY IS STRICTLY PROHIBITED.

1.2 OPERATION OF EQUIPMENT IS TO BE PERFORMED IN ACCORDANCE WITH THE APPLICABLE OCCUPATIONAL HEALTH AND SAFETY (OH&S) REGULATIONS. ANY SPECIFICATIONS LISTED ARE INTENDED TO BRING ATTENTION TO SPECIFIC AREAS OF INTEREST, OR POSSIBLE HAZARDS, AND TO BE USED IN CONJUNCTION WITH THE APPLICABLE OH&S REGULATIONS.

1.3 A SAFE WORK PROCEDURE FOR THE USE OF THE GROUND CLAMP SHALL BE PREPARED BY A COMPETENT PERSON. THE SAFE WORK PROCEDURE SHALL BE AVAILABLE ON SITE FOR REVIEW.

2 SPECIFICATIONS

2.1 THE GROUND CLAMP IS TO BE PERMANENTLY MARKED WITH THE FOLLOWING:

CERTIFIED BY: ARSENAL ENGINEERING

MODEL NO.: GC-001

SERIAL NO.: 001

2.2 A LABEL SHALL BE AFFIXED, REFERRING USER TO CONSULT MANUFACTURER'S INSTRUCTION MANUAL FOR PRODUCT SAFETY INFORMATION.

2.3 ALL HAZARDS THAT ARE IDENTIFIED IN A SAFETY AUDIT OF THIS EQUIPMENT ARE TO BE LABELED.

3 FABRICATION

3.1 ALL STEEL WELDMENTS SHALL CONFORM TO LATEST EDITION OF CSA STANDARD W59.1

3.2 ALL MATERIALS TO BE MADE FROM STAINLESS STEEL

3.3 FABRICATOR TO CONFIRM DIMENSIONS FOR PROPER FIT UP.

3.4 ALL HOLES TO BE DRILLED OR HAVE EQUIVALENT SURFACE ROUGHNESS (NO FLAME CUTTING)

3.5 THIS CERTIFICATION PERTAINS TO THE LIMITED MANUFACTURING (SMALL RUN) OF THIS GROUND CLAMP WITH A MAXIMUM QUANTITY OF 20 ITEMS

4 INSPECTION

4.1 DOCUMENTED FUNCTION TEST OF ALL EQUIPMENT OPERATIONS.

4.2 START OF SHIFT (UNDOCUMENTED) INSPECTIONS SHALL BE PERFORMED BY THE OPERATOR TO LOOK FOR: DEFORMED MEMBERS, LOOSE BOLTS, WORN, CRACKED, OR DISTORTED PARTS, ETC.

4.3 PERIODIC (MONTHLY) DOCUMENTED INSPECTIONS SHALL BE PERFORMED BY THE EQUIPMENT OWNER/OPERATOR TO LOOK FOR: CONTINUITY, DEFORMED MEMBERS, LOOSE BOLTS, WORN, CRACKED, OR DISTORTED PARTS, ETC.

4.4 MAXIMUM ALLOWABLE RESISTANCE MEASURED IN CONTINUITY CHECK IS 25 OHMS.

4.54 ANY REPAIRS OR MODIFICATIONS TO THE GROUND CLAMP ARE TO BE PERFORMED UNDER THE DIRECTION OF A PROFESSIONAL ENGINEER.

5 LIABILITY

5.1 ARSENAL ENGINEERING LTD OR THE UNDERSIGNED ENGINEER ARE NOT LIABLE FOR ANY CLAIMS RESULTING FROM THIRD PARTY USE.

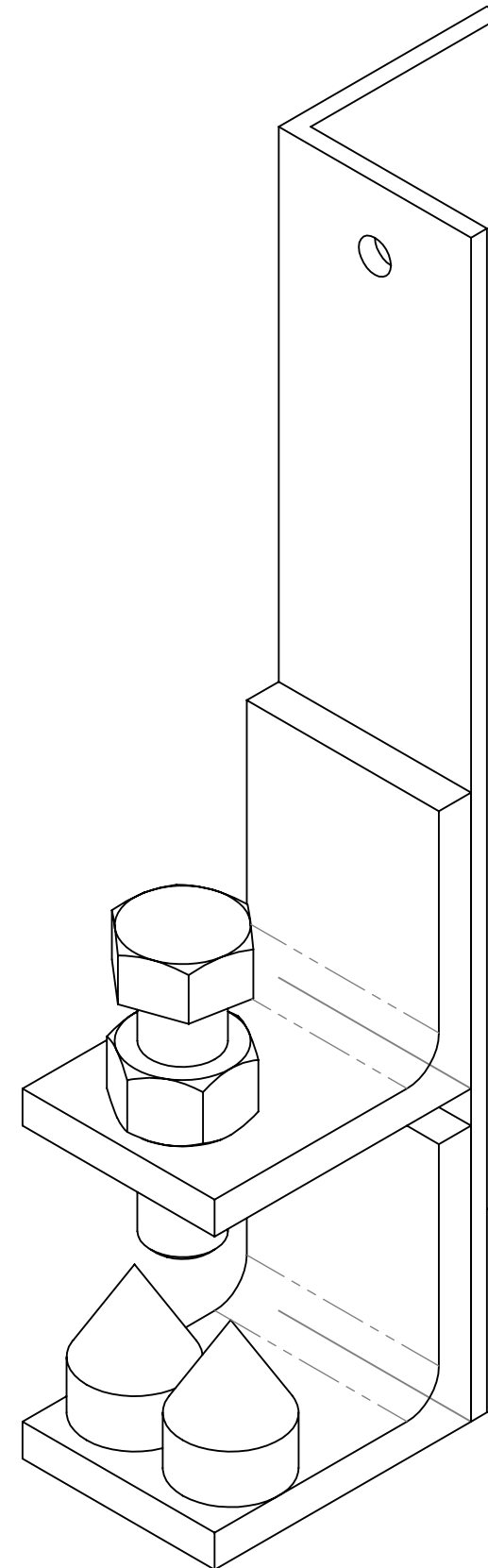

1. © 2016 ARSENAL ENGINEERING LTD. ALL RIGHTS RESERVED. THIS DOCUMENT IS PROTECTED BY COPYRIGHT LAW AND MAY NOT BE REPRODUCED IN ANY FORM EXCEPT BY WRITTEN PERMISSION OF ARSENAL ENGINEERING LTD.
2. LIABILITY IS LIMITED TO THE COST OF ONE REDESIGN.

UNLESS OTHERWISE SPECIFIED DIMENSIONS ARE IN INCHES (IN).
TOLERANCES:
DIMENSIONAL ± 1/16 ANGULAR ± .5
REMOVE ALL BURRS AND BREAK SHARP EDGES.

CLIENT:
R U GROUNDED ENERGY INC.

PROJECT:
GROUNDING CLAMP

DWG NO.: **AE-0219070**

REV:
-

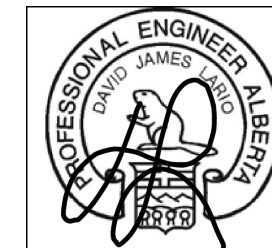

Date April 12, 2019
Member M65014
Permit P12933

SIZE: **B** SHEET 1 OF 5

\\arsenal\p1\15_2019\04_12_2019\0219070\0219070 (R U Grounded Energy) - Engineering of Grounding Clamp\Drawings\BeamClamp w Ground Lug Rev8

8 7 6 5 4 3 2 1

BILL OF MATERIALS

ITM	QTY	DESCRIPTION	SIZE	MATERIAL
1	2	ANGLE 1-1/2"x1-1/2"x3/16" THK	8"	STAINLESS STEEL
2	2	ANGLE 2"x2"x1/4" THK	1.5"	STAINLESS STEEL
3	2	RB 0.75" DIA	1"	4340
4	1	HEX NUT 1/2" UNC		SAE GRADE 8
5	1	BOLT 1/2" UNC	1.75"	SAE GRADE 8

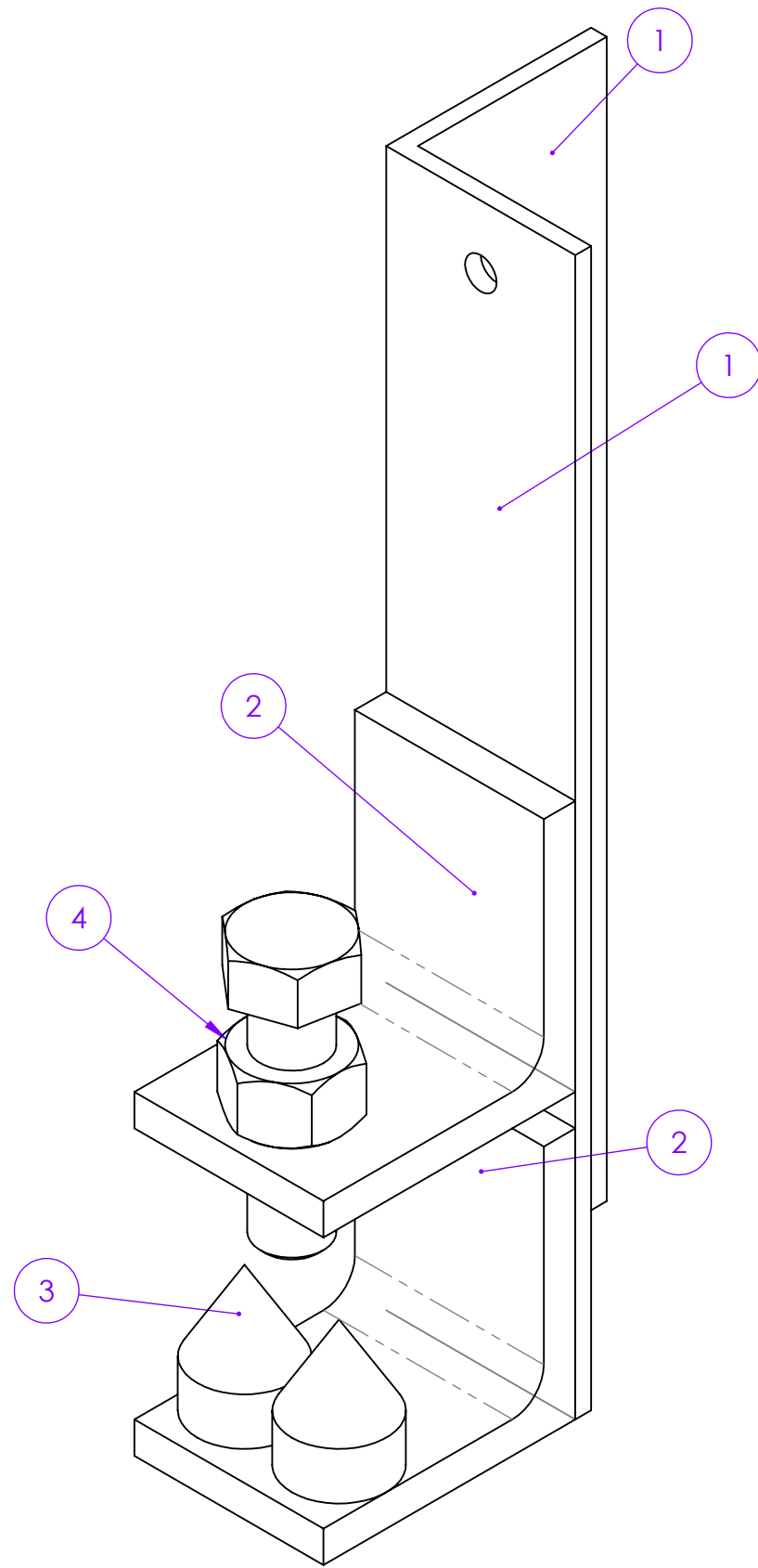

1. © 2016 ARSENAL ENGINEERING LTD. ALL RIGHTS RESERVED. THIS DOCUMENT IS PROTECTED BY COPYRIGHT LAW AND MAY NOT BE REPRODUCED IN ANY FORM EXCEPT BY WRITTEN PERMISSION OF ARSENAL ENGINEERING LTD.
 2. LIABILITY IS LIMITED TO THE COST OF ONE REDESIGN.

UNLESS OTHERWISE SPECIFIED DIMENSIONS ARE IN INCHES (IN).
TOLERANCES:
 DIMENSIONAL ± 1/16 ANGULAR ± .5
 REMOVE ALL BURRS AND BREAK SHARP EDGES.

CLIENT:
 R U GROUNDED ENERGY INC.

PROJECT:
 GROUNDING CLAMP

DWG NO.: **AE-0219070**

REV:
 -

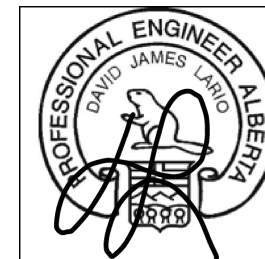

Date April 12, 2019
 Member M65014
 Permit P12933

SIZE: **B** SHEET 2 OF 5

8 7 6 5 4 3 2 1 SCALE: 1:1

I:\E\AN\REV D\REV E\REV F\REV G\REV H\REV I\REV J\REV K\REV L\REV M\REV N\REV O\REV P\REV Q\REV R\REV S\REV T\REV U\REV V\REV W\REV X\REV Y\REV Z\REV AA\REV AB\REV AC\REV AD\REV AE\REV AF\REV AG\REV AH\REV AI\REV AJ\REV AK\REV AL\REV AM\REV AN\REV AO\REV AP\REV AQ\REV AR\REV AS\REV AT\REV AU\REV AV\REV AW\REV AX\REV AY\REV AZ\REV BA\REV BB\REV BC\REV BD\REV BE\REV BF\REV BG\REV BH\REV BI\REV BJ\REV BK\REV BL\REV BM\REV BN\REV BO\REV BP\REV BQ\REV BR\REV BS\REV BT\REV BU\REV BV\REV BV\REV BW\REV BX\REV BY\REV BZ\REV CA\REV CB\REV CC\REV CD\REV CE\REV CF\REV CG\REV CH\REV CI\REV CJ\REV CK\REV CL\REV CM\REV CN\REV CO\REV CP\REV CQ\REV CR\REV CS\REV CT\REV CU\REV CV\REV CW\REV CX\REV CY\REV CZ\REV DA\REV DB\REV DC\REV DD\REV DE\REV DF\REV DG\REV DH\REV DI\REV DJ\REV DK\REV DL\REV DM\REV DN\REV DO\REV DP\REV DQ\REV DR\REV DS\REV DT\REV DU\REV DV\REV DV\REV DW\REV DX\REV DY\REV DZ\REV EA\REV EB\REV EC\REV ED\REV EE\REV EF\REV EG\REV EH\REV EI\REV EJ\REV EK\REV EL\REV EM\REV EN\REV EO\REV EP\REV EQ\REV ER\REV ES\REV ET\REV EU\REV EV\REV EV\REV EW\REV EX\REV EY\REV EZ\REV FA\REV FB\REV FC\REV FD\REV FE\REV FF\REV FG\REV FH\REV FI\REV FJ\REV FK\REV FL\REV FM\REV FN\REV FO\REV FP\REV FQ\REV FR\REV FS\REV FT\REV FU\REV FV\REV FV\REV FW\REV FX\REV FY\REV FZ\REV GA\REV GB\REV GC\REV GD\REV GE\REV GF\REV GG\REV GH\REV GI\REV GJ\REV GK\REV GL\REV GM\REV GN\REV GO\REV GP\REV GQ\REV GR\REV GS\REV GT\REV GU\REV GV\REV GV\REV GW\REV GX\REV GY\REV GZ\REV HA\REV HB\REV HC\REV HD\REV HE\REV HF\REV HG\REV HH\REV HI\REV HJ\REV HK\REV HL\REV HM\REV HN\REV HO\REV HP\REV HQ\REV HR\REV HS\REV HT\REV HU\REV HV\REV HV\REV HW\REV HX\REV HY\REV HZ\REV IA\REV IB\REV IC\REV ID\REV IE\REV IF\REV IG\REV IH\REV II\REV IJ\REV IK\REV IL\REV IM\REV IN\REV IO\REV IP\REV IQ\REV IR\REV IS\REV IT\REV IU\REV IV\REV IV\REV IW\REV IX\REV IY\REV IZ\REV JA\REV JB\REV JC\REV JD\REV JE\REV JF\REV JG\REV JH\REV JI\REV JJ\REV JK\REV JL\REV JM\REV JN\REV JO\REV JP\REV JQ\REV JR\REV JS\REV JT\REV JU\REV JV\REV JV\REV JW\REV JX\REV JY\REV JZ\REV KA\REV KB\REV KC\REV KD\REV KE\REV KF\REV KG\REV KH\REV KI\REV KJ\REV KK\REV KL\REV KM\REV KN\REV KO\REV KP\REV KQ\REV KR\REV KS\REV KT\REV KU\REV KV\REV KV\REV KW\REV KX\REV KY\REV KZ\REV LA\REV LB\REV LC\REV LD\REV LE\REV LF\REV LG\REV LH\REV LI\REV LJ\REV LK\REV LL\REV LM\REV LN\REV LO\REV LP\REV LQ\REV LR\REV LS\REV LT\REV LU\REV LV\REV LV\REV LW\REV LX\REV LY\REV LZ\REV MA\REV MB\REV MC\REV MD\REV ME\REV MF\REV MG\REV MH\REV MI\REV MJ\REV MK\REV ML\REV MM\REV MN\REV MO\REV MP\REV MQ\REV MR\REV MS\REV MT\REV MU\REV MV\REV MV\REV MW\REV MX\REV MY\REV MZ\REV NA\REV NB\REV NC\REV ND\REV NE\REV NF\REV NG\REV NH\REV NI\REV NJ\REV NK\REV NL\REV NM\REV NO\REV NP\REV NQ\REV NR\REV NS\REV NT\REV NU\REV NV\REV NV\REV NW\REV NX\REV NY\REV NZ\REV OA\REV OB\REV OC\REV OD\REV OE\REV OF\REV OG\REV OH\REV OI\REV OJ\REV OK\REV OL\REV OM\REV ON\REV OO\REV OP\REV OQ\REV OR\REV OS\REV OT\REV OU\REV OV\REV OV\REV OW\REV OX\REV OY\REV OZ\REV PA\REV PB\REV PC\REV PD\REV PE\REV PF\REV PG\REV PH\REV PI\REV PJ\REV PK\REV PL\REV PM\REV PN\REV PO\REV PP\REV PQ\REV PR\REV PS\REV PT\REV PU\REV PV\REV PV\REV PW\REV PX\REV PY\REV PZ\REV QA\REV QB\REV QC\REV QD\REV QE\REV QF\REV QG\REV QH\REV QI\REV QJ\REV QK\REV QL\REV QM\REV QN\REV QO\REV QP\REV QQ\REV QR\REV QS\REV QT\REV QU\REV QV\REV QV\REV QW\REV QX\REV QY\REV QZ\REV RA\REV RB\REV RC\REV RD\REV RE\REV RF\REV RG\REV RH\REV RI\REV RJ\REV RK\REV RL\REV RM\REV RN\REV RO\REV RP\REV RQ\REV RR\REV RS\REV RT\REV RU\REV RV\REV RV\REV RW\REV RX\REV RY\REV RZ\REV SA\REV SB\REV SC\REV SD\REV SE\REV SF\REV SG\REV SH\REV SI\REV SJ\REV SK\REV SL\REV SM\REV SN\REV SO\REV SP\REV SQ\REV SR\REV SS\REV ST\REV SU\REV SV\REV SV\REV SW\REV SX\REV SY\REV SZ\REV TA\REV TB\REV TC\REV TD\REV TE\REV TF\REV TG\REV TH\REV TI\REV TJ\REV TK\REV TL\REV TM\REV TN\REV TO\REV TP\REV TQ\REV TR\REV TS\REV TT\REV TU\REV TV\REV TV\REV TW\REV TX\REV TY\REV TZ\REV UA\REV UB\REV UC\REV UD\REV UE\REV UF\REV UG\REV UH\REV UI\REV UJ\REV UK\REV UL\REV UM\REV UN\REV UO\REV UP\REV UQ\REV UR\REV US\REV UT\REV UU\REV UV\REV UV\REV UW\REV UX\REV UY\REV UZ\REV VA\REV VB\REV VC\REV VD\REV VE\REV VF\REV VG\REV VH\REV VI\REV VJ\REV VK\REV VL\REV VM\REV VN\REV VO\REV VP\REV VQ\REV VR\REV VS\REV VT\REV VU\REV VV\REV VW\REV VX\REV VY\REV VZ\REV WA\REV WB\REV WC\REV WD\REV WE\REV WF\REV WG\REV WH\REV WI\REV WJ\REV WK\REV WL\REV WM\REV WN\REV WO\REV WP\REV WQ\REV WR\REV WS\REV WT\REV WU\REV WV\REV WV\REV WY\REV WX\REV WY\REV WZ\REV XA\REV XB\REV XC\REV XD\REV XE\REV XF\REV XG\REV XH\REV XI\REV XJ\REV XK\REV XL\REV XM\REV XN\REV XO\REV XP\REV XQ\REV XR\REV XS\REV XT\REV XU\REV XV\REV XV\REV XW\REV XX\REV XY\REV XZ\REV YA\REV YB\REV YC\REV YD\REV YE\REV YF\REV YG\REV YH\REV YI\REV YJ\REV YK\REV YL\REV YM\REV YN\REV YO\REV YP\REV YQ\REV YR\REV YS\REV YT\REV YU\REV YV\REV YV\REV YW\REV YX\REV YZ\REV ZA\REV ZB\REV ZC\REV ZD\REV ZE\REV ZF\REV ZG\REV ZH\REV ZI\REV ZJ\REV ZK\REV ZL\REV ZM\REV ZN\REV ZO\REV ZP\REV ZQ\REV ZR\REV ZS\REV ZT\REV ZU\REV ZV\REV ZV\REV ZW\REV ZX\REV ZY\REV ZZ

BILL OF MATERIALS				
ITM	QTY	DESCRIPTION	SIZE	MATERIAL
2	2	ANGLE 2"x2"x1/4" THK	1.5"	STAINLESS STEEL
3	2	RB 0.75" DIA	1"	4340

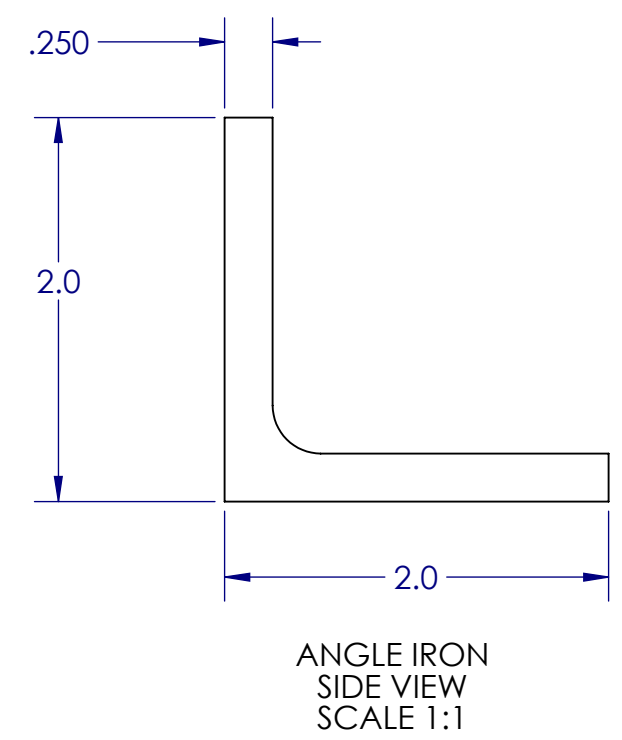
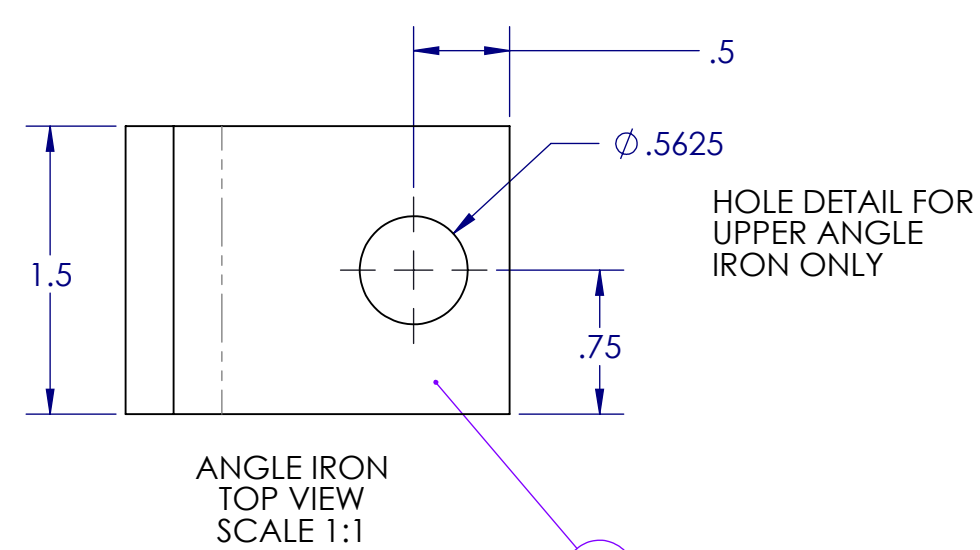

CONTACT POINTS
SIDE VIEW
SCALE 1:1

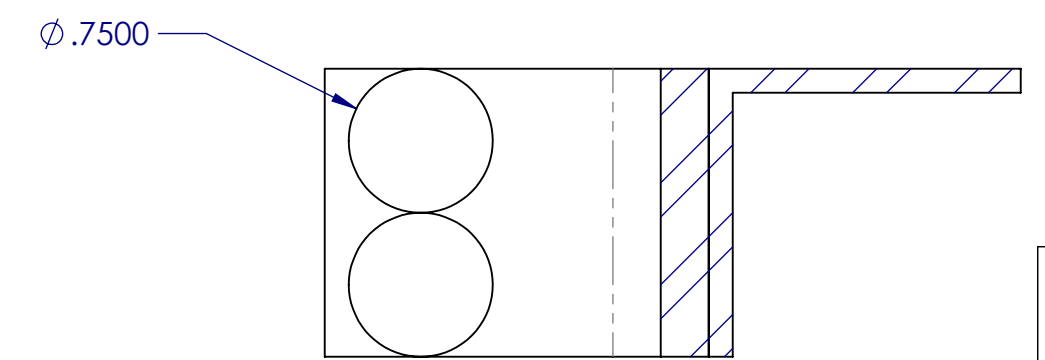
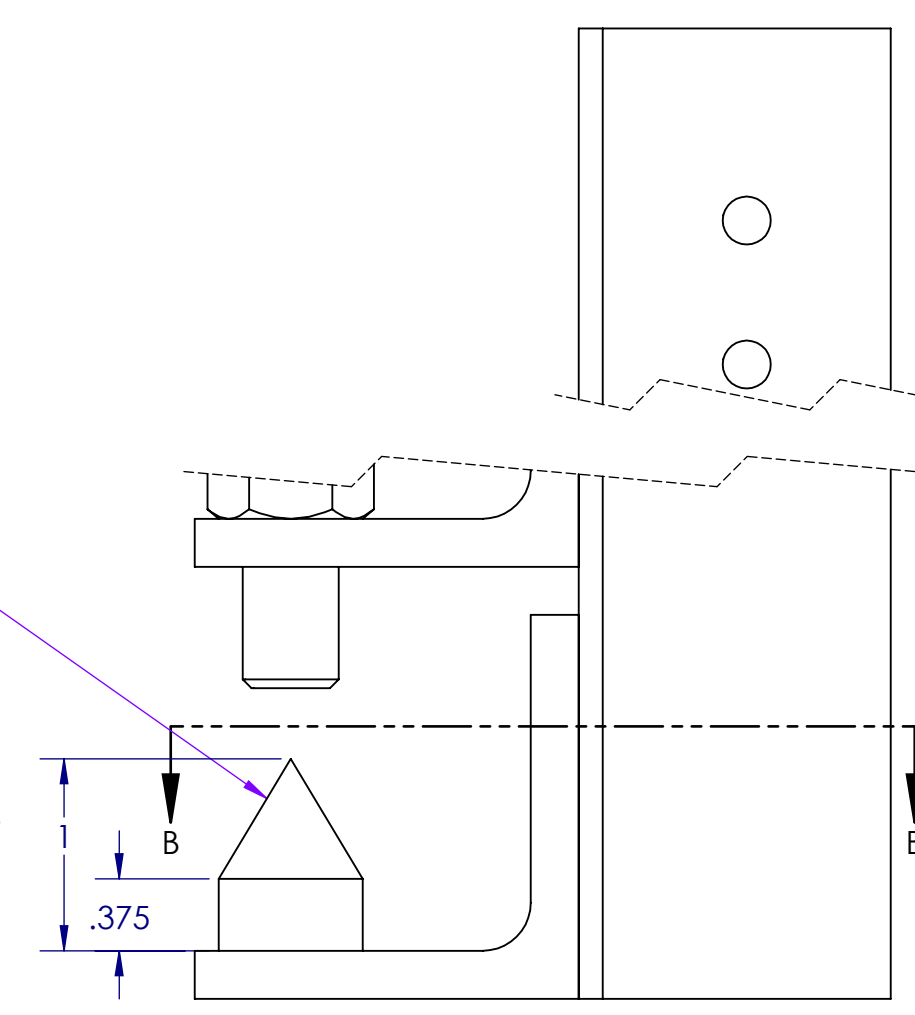

1. © 2016 ARSENAL ENGINEERING LTD. ALL RIGHTS RESERVED. THIS DOCUMENT IS PROTECTED BY COPYRIGHT LAW AND MAY NOT BE REPRODUCED IN ANY FORM EXCEPT BY WRITTEN PERMISSION OF ARSENAL ENGINEERING LTD.
2. LIABILITY IS LIMITED TO THE COST OF ONE REDESIGN.

UNLESS OTHERWISE SPECIFIED DIMENSIONS ARE IN INCHES (IN).
TOLERANCES:
DIMENSIONAL $\pm 1/16$ ANGULAR $\pm .5$
REMOVE ALL BURRS AND BREAK SHARP EDGES.

CLIENT:
R U GROUNDED ENERGY INC.

PROJECT:
GROUNDING CLAMP

DWG NO.: **AE-0219070** REV: -

SIZE: **B** SHEET 3 OF 5

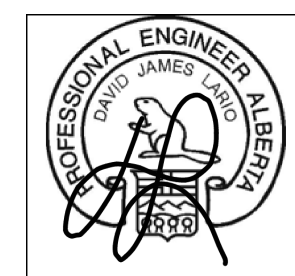

Date	April 12, 2019
Member	M65014
Permit	P12933

L:\PROJECTS\2019\AE-0219070\0219070 (R U Grounded) (Category) - Engineering of Grounding Clamps\BeamClamp w GroundLug Rev8
 FILEPATH:\D:\projects\2019\AE-0219070\0219070 (R U Grounded) (Category) - Engineering of Grounding Clamps\BeamClamp w GroundLug Rev8

L:\PROJECTS\2019\AE-0219070 (R U Grounded Energy Inc)\Drawings\BeamClamp w GroundLug Rev8
 FILEPATH:\D:\Projects\Aerial\Drawings\Aerial\Drawings\BeamClamp w GroundLug Rev8

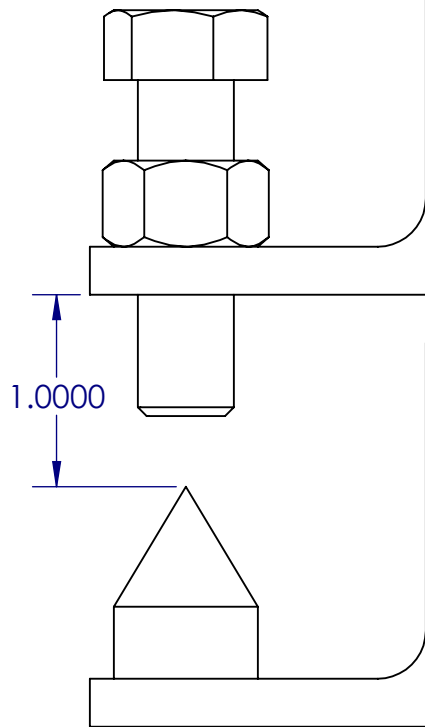

4X - \emptyset .25 THRU

OVERALL
SIDE VIEW
SCALE 1:1

\emptyset .25 THRU

OVERALL
REAR VIEW
SCALE 1:1



1. © 2016 ARSENAL ENGINEERING LTD. ALL RIGHTS RESERVED. THIS DOCUMENT IS PROTECTED BY COPYRIGHT LAW AND MAY NOT BE REPRODUCED IN ANY FORM EXCEPT BY WRITTEN PERMISSION OF ARSENAL ENGINEERING LTD.
 2. LIABILITY IS LIMITED TO THE COST OF ONE REDESIGN.

UNLESS OTHERWISE SPECIFIED DIMENSIONS ARE IN INCHES (IN).
TOLERANCES:
 DIMENSIONAL $\pm 1/16$ ANGULAR $\pm .5$
 REMOVE ALL BURRS AND BREAK SHARP EDGES.

CLIENT:
 R U GROUNDED ENERGY INC.

PROJECT:
 GROUNDING CLAMP

DWG NO.: **AE-0219070**

REV:
 -

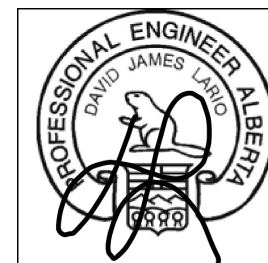

Date	April 12, 2019
Member	M65014
Permit	P12933

SIZE: **B** SHEET 4 OF 5

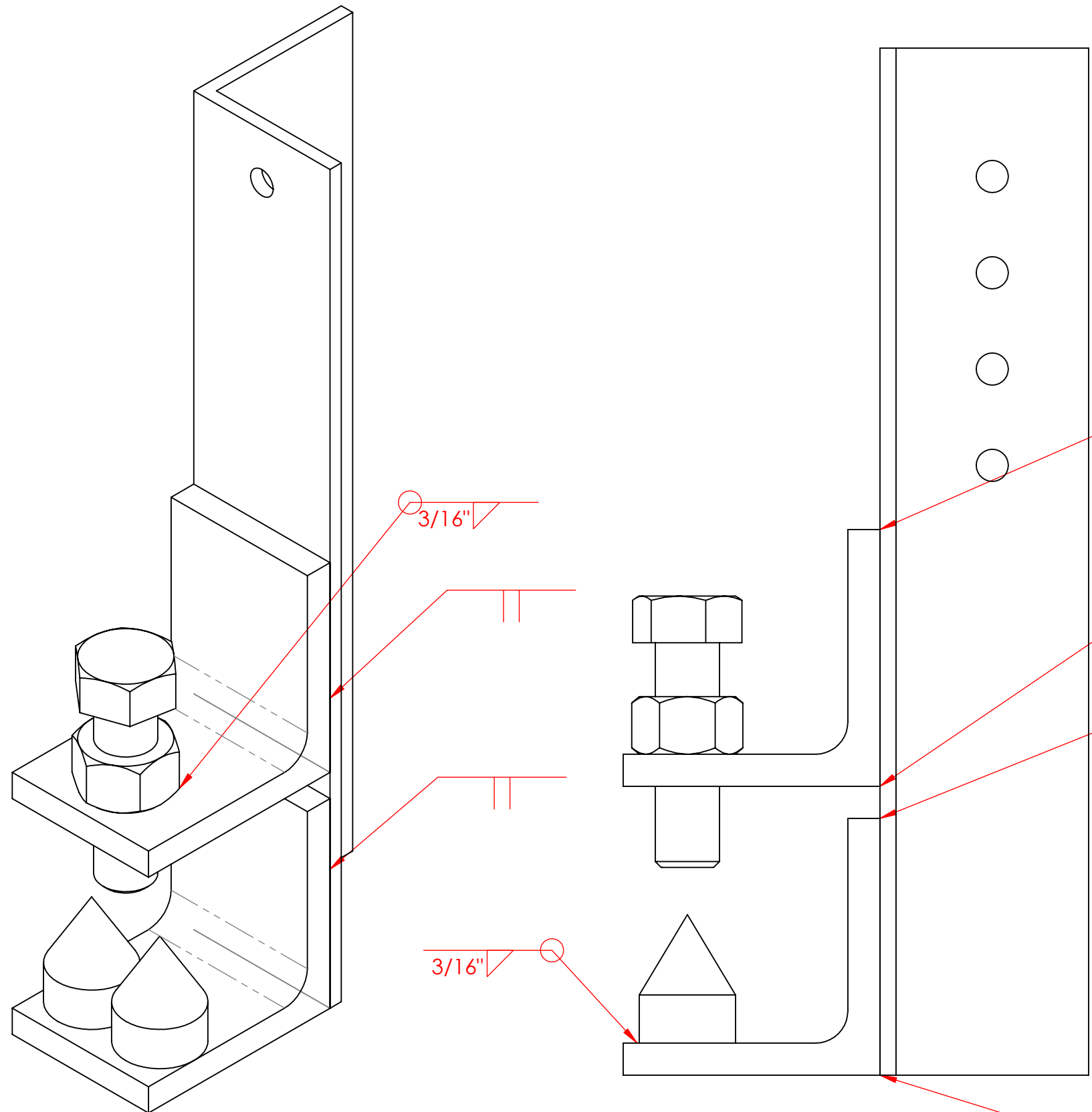

L:\PROJECTS\2019\4675\4675.dwg (R:\GROUNDED\Drawings\BeamClamp w GroundLug Rev8
 FILEPATH\Drawings\BeamClamp w GroundLug Rev8



1. © 2016 ARSENAL ENGINEERING LTD. ALL RIGHTS RESERVED. THIS DOCUMENT IS PROTECTED BY COPYRIGHT LAW AND MAY NOT BE REPRODUCED IN ANY FORM EXCEPT BY WRITTEN PERMISSION OF ARSENAL ENGINEERING LTD.
 2. LIABILITY IS LIMITED TO THE COST OF ONE REDESIGN.

UNLESS OTHERWISE SPECIFIED DIMENSIONS ARE IN INCHES (IN).
TOLERANCES:
 DIMENSIONAL $\pm 1/16$ ANGULAR $\pm .5$
 REMOVE ALL BURRS AND BREAK SHARP EDGES.

CLIENT:
 R U GROUNDED ENERGY INC.

PROJECT:
 GROUNDING CLAMP

DWG NO.: AE-0219070 **REV:** -

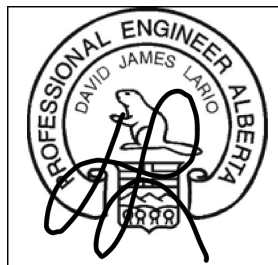

Date	April 12, 2019
Member	M65014
Permit	P12933

SIZE: B **SHEET 5 OF 5**

SCALE: 1:1