

Revolutionary High Speed Technology

Power, Precision and Reliability: 25,000 - 90,000 rpm to 1.40 hp

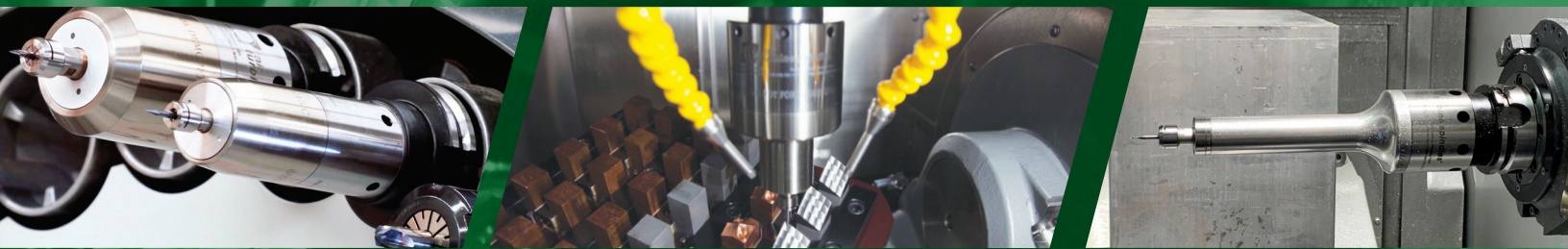

Are Your Machine Spindle Speeds Too Low?

Detail work taking hours?

Breaking too many tools?

Cutting speeds required to optimize smaller tools cannot be achieved using standard machine spindles. If high speeds are required many machines are pushed to the limit and your machine is tied up for days.

What is the answer?

Utilize the compressed air at your machine.

Air Turbine Spindles[®] are powerful governed direct drives. Unlike speeders and coolant driven spindles, our spindles maintain speed when cutting, even corners and hard materials. That's a difference you will see immediately.

Want to save time and money?

Constant high speed on the tool path makes *Air Turbine Spindles*[®] ideal for precision micro machining, milling, slotting, drilling and profiling with small tools. You will dramatically increase cutting rates and reduce your cycle times.

Why are our spindles superior?

Air Turbine Spindles[®] generate low heat, low vibration and operate reliably with no duty cycle in 24/7 non-stop operations. That's because there are only two moving parts in these patented precision spindles – air cooled ceramic bearings and the turbine. There are no gears, high frequency brushes or vanes to burn out like in speeders or electric spindles. So you get no thermal expansion and great reliability while reducing wear on your main spindle.

Just connect compressed air, enter an M Code to mill at 400"/min (10,000 mm/min) with 2μ accuracy.



Patented Technology: Governed 25,000 - 90,000 rpm • Power to 1.60 hp (1.19 kW) • No Duty Cycle • No Thermal Expansion

COMPARISON OF CUTTING SPEED PER MINUTE WITH A 1.5 mm END MILL:

Standard Machine Spindle at 12,000 rpm = **2.22" /min (56.5 mm/min) advance**

Air Turbine Spindles[®] 625 Series at constant 50,000 rpm = **9.28" /min (235.6 mm/min) advance**

Your Cutting Speed is increased 4.2x with *Air Turbine Spindles*[®]

In addition to reducing cycle time the accuracy of the cutting tool is improved and its life extended

$$V_c = \frac{D \times \pi \times n}{1000}$$

V_c = Cutting Speed
 D = Tool Size
 n = Spindle Speed Rating

Our Advantages at a Glance



Constant High Cutting Speed Reduces Cycle Times.



Longer Tool Life. Faster Production.

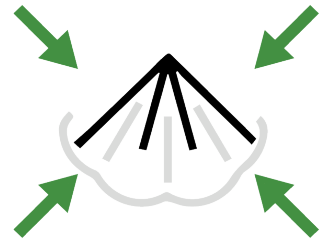

Low Heat. No Thermal Expansion.



Mill 24/7. No Duty Cycle.

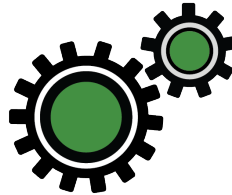

Direct Drive Reliability. Only 2 Moving Parts. No Maintenance.

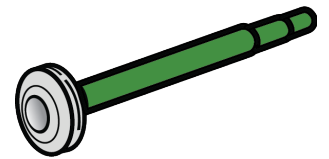

Governor Control for Constant High Torque. Maintains High Speed under Load.

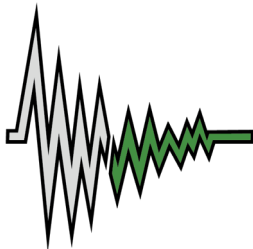

Low Vibration. Quiet - Under 78 dBA.



Environmentally Friendly (No Oil or Lubrication)

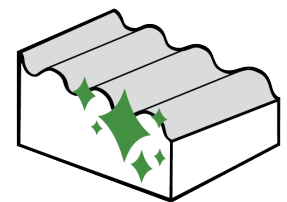

Improved Surface Quality. No Secondary Finishing.

A SIMPLE EXAMPLE OF THE SAVINGS ACHIEVED WITH AIR TURBINE SPINDLES®:

Example: A standard machine spindle at 12,000 rpm produces 1 part in 75 minutes.

Production Run of 500 Pieces:

Machine Spindle: 500 pieces x 75 minutes = **625 hours**

Air Turbine Spindles® (50,000 rpm): 500 pieces x 10 minutes = **83.3 hours**

Result: Time saved = **541.7 hours**

HIGH SPEED SPINDLES

The Air Turbine Differences

Low Vibration, Quiet:

- $< 0.4 \text{ mm/s}^2 < 78 \text{ dBA}$.

High Precision:

- 2 Micron Ultra Precision ER 8 or ER 11 Collet Standard.
- No thermal expansion.

Powerful Constant High Speed and Power:

- Patented governed turbine maintains constant high speed under load.
- Accelerate cycle times and optimize cutting tool performance and life.
- Eliminate secondary finishing.

Flexibility:

- Center rear air feed, patented stop block + collar (TMA), or manual side connection.

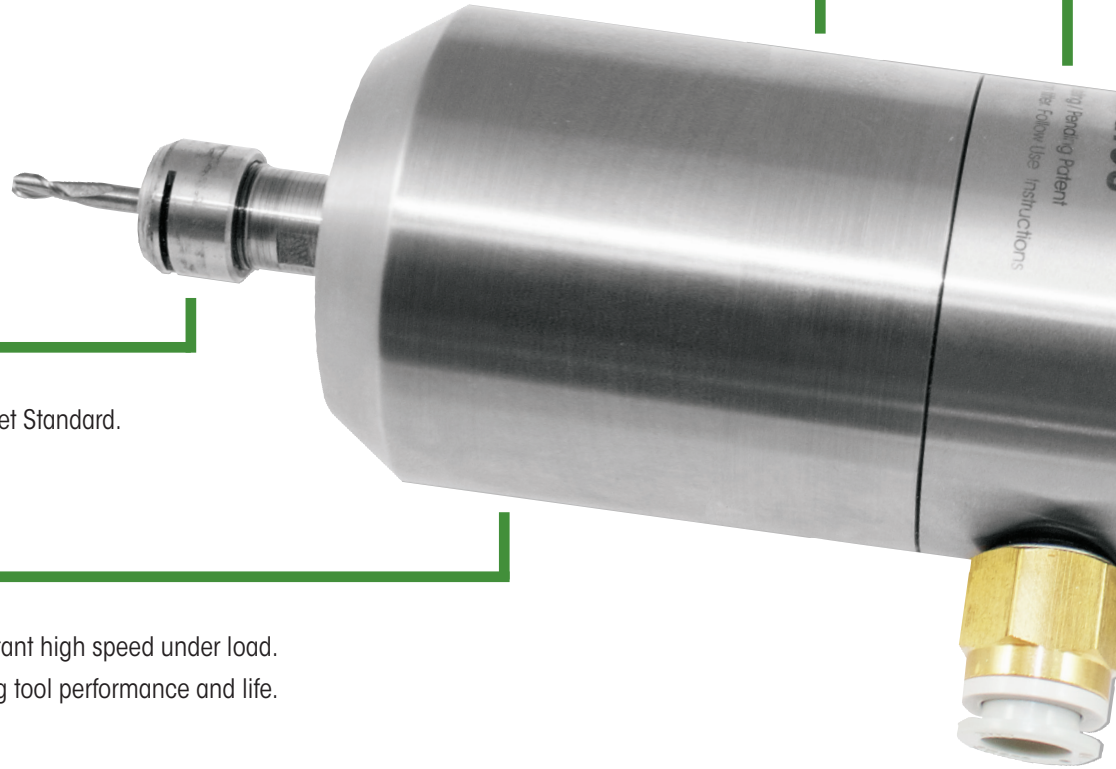

AUTOLOADING OPTIONS

Reduce setup time and increase productivity by incorporating autoloading in your production.

Air Turbine Spindles® give you two options for autoloading.

1. Connect rear air inlet to compressed air feed in your CNC spindle.
2. Fully automate your spindle change with our Tool Changer Mounting Assembly (TMA).



Dry, clean 90 psi / 6.2 bar air only. Filter Extractor included as standard equipment.

Reliable:

- Only two moving parts (Turbine and Bearings).
- Air cooled ceramic bearings.
- No Duty Cycle.

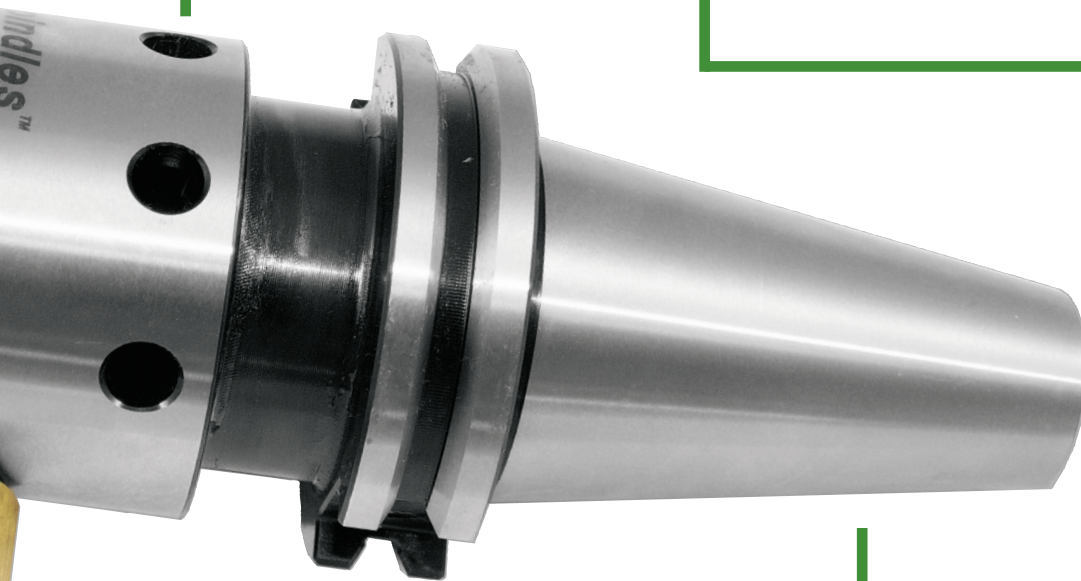

Shown: 625 CAT/DIN/BT
0.55 hp - Governed 65,000 rpm.

Patented Direct Drive Motor:

- Low friction and heat.
- No gears, high frequency brushes, or vanes to heat up or burn out.
- Long Service Life.

Customize Your Spindle:

- Available in all popular tool holder designs.
- Retrofit any CNC.

AUTOMATICALLY TOOL CHANGE ON DEMAND

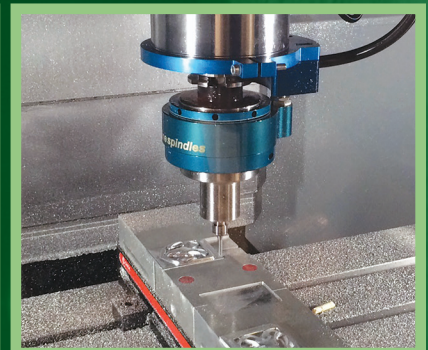
1.**CENTER AIR FEED****2.****TOOLCHANGER MOUNTING ASSEMBLY (TMA)**

LEARN MORE ABOUT OUR PATENTED TMA SYSTEM ON PAGE 20

Application Examples



STEEL ROW MILLING ON DMG HSC 55

Linear Milling Depth: Row depth 2.0-0.13 RA

Material: 1.2344 Steel – HSC 30/70

Tool: Ball Nose End Mill R 2, 0.03mm/z

Standard DMG HSC 55 Spindle - 25,000 rpm

Advance: 1,500 mm/min = Cycle Time: **60 minutes**

Air Turbine Spindles® 625HSK Spindle - 50,000 rpm

Advance: 3,000 mm/min = Cycle Time: **30 minutes**

Cycle time halved with surface quality Ra 0.13.



BONDED CARBON FIBER ON HAAS VF6

Flying S, a successful manufacturer of aerospace components in Illinois, needed to cut carbon fiber bonded to hardened material at production speeds with an 1/16th or 0.625 end mill in a way that did not destroy the material.

Unable to make the part at the 7,500 rpm speed of the Haas VF6 machine spindle, Flying S installed the autoloading **650CAT40 with TMA**.

Flying S transformed its CNC into a high speed machine, milling in composites and hardened steel parts. Bur free surface quality and extended tool life combine with oil free operation, eliminating part contamination.

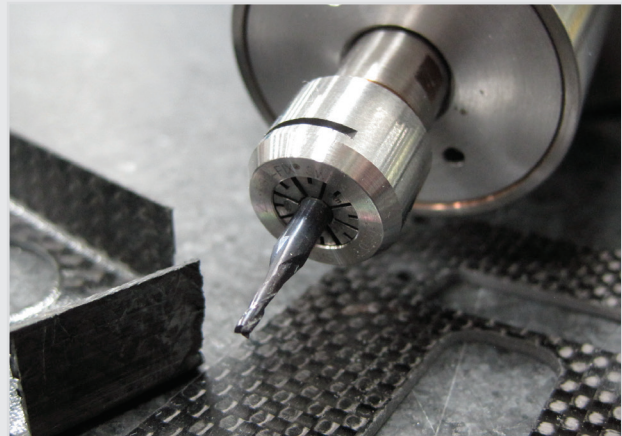

Spindle Selection Guide

All Air Turbine Spindles® are direct drives with our patented high torque governor maintaining high speed and torque under cutting load up to 80% of rated maximum power. This ensures continuous toolpath engagement at high speed in angles and hard materials for trochoidal milling and optimized cutting tool performance. X= Extra Power.

Optimum Spindle for Each Tool					
			√ = Optimum ∞ = Acceptable	x = Not recommended for use ! = Dependent upon cutting conditions	
		602	625(X)	650(X)	660
Drill	Ø 0.1 - 0.3mm	√	√	√	√
	Ø 0.3 - 0.5mm	∞	√	√	√
	Ø 0.5 - 1.0mm	!	√	√	√
	Ø 1.0 - 1.5mm	x	∞	√	√
	Ø 1.5 - 2.0mm	x	!	√	√
Endmill	Ø 0.1 - 1.0mm	√	√	√	√
	Ø 1.0 - 2.0mm	√	√	√	√
	Ø 2.0 - 3.5mm	!	√	√	√
	Ø 3.5 - 5.0mm	x	∞	√	√
	Ø 5.0 - 6.0mm	x	!	∞	∞
Jig Grinding		x	!	√	√
General Specifications		602	625(X)	650(X)	660
Speed (rpm)		40,000 50,000 65,000 90,000*	30,000 40,000 50,000 65,000	25,000 30,000 40,000	50,000
Material Capacity (General Rule)		6061 aluminum and softer - rubber, plastic, graphite, wood, ect	Aluminum and softer for standard high speed machining. All materials if light cutting, finish cutting, engraving, ect	All material capacity - Titanium, inconel ceramics, mold steel, tool steel, and softer	All material capacity - Titanium, inconel, ceramics, mold steel, tool steel, and softer
Average DOC (mm)		0.01 - 0.127	0.01 - 0.305	0.01 - 0.508	0.01 - 0.508
Power - hp		0.15 - 0.20	0.40 - 0.78	0.80 - 1.40	0.91 - 1.60
Collet Range		0.5mm - 3mm	0.5mm - 7mm	0.5mm - 7mm	0.5mm - 7mm
T.I.R. at Nose		Less than 2µm			
Air Pressure		6.2 Bar (0.62 MPa)			

*Due to its governed high speed and power the 602 90,000 rpm is for use only with micro end mills in special applications

DRILL TAP SPINDLES

625DT Series

Mount the patented **625DT** Series spindles in any Drill Tap Machine magazine for **30,000, 40,000, or 50,000 rpm** with **0.50 hp (0.37 kW)**. Increase milling and drilling feed rates resulting in higher productivity with no duty cycle for true 24/7 unattended production. More air is induced on demand to correspond to cutting load Keeping your rated speed high on the tool path. Compatible with all Robodrill, Brother, Haas DT and other DT machines. Just connect 90 PSI. No control system or lubrication. PG-6 PowRgrip® collet optional for 0µ and rigidity; see specifications on page 19.

Dimensions

Many integrated shank dimensions (BT, CAT, DIN, ISO, HSK) available at www.airturbinetools.com

BT30	
A	1.01" (26mm)
B	2.24" (57mm)
C	6.43" (163mm)
D	8.39" (213mm)
E	RoboDrill: 3.16" (80mm) • Brother TC: 3.58" (91mm) • Haas DT: 2.56" (65mm)

General Specifications

Governed Speed rpm	30,000 / 40,000 / 50,000
Power Rating hp (kW)	0.40 (0.30) / 0.45 (0.34) / 0.50 (0.37)
Inlet Air Pressure (clean dry air only)	90 PSI (6.2 Bar)
Air Consumption Idle cfm (l/s)	10.5 (4.9) / 11 (5.2) / 11 (5.2)
Air Consumption Working Flow cfm (l/s)	11 (5.2) - 20 (9.4)
Sound Level	Less Than 78 dBA
Max Shank Capacity	ER 11 - 1/4" (6mm)
Spindle Weight	74.6 oz (2.11 kg)
Coupling / Hose Min. Internal Diameter	0.31" (8mm)

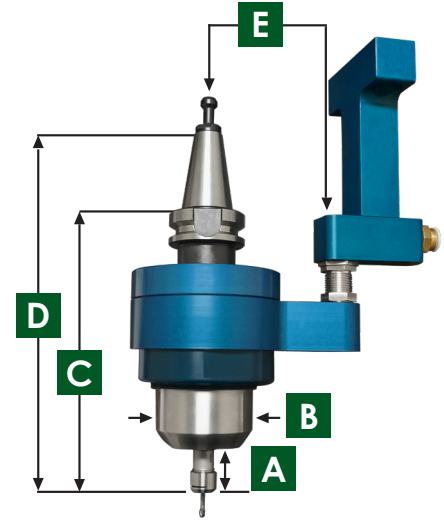

625DT BT30 Shown

Cutting Tool Guide

<p>√ = Optimum</p> <p>∞ = Acceptable</p> <p>× = Not recommended for use</p> <p>! = Dependent upon cutting conditions</p>	Drill					
	Diameter	0.1 - 0.3 mm	0.3 - 0.5 mm	0.5 - 1.0 mm	1.0 - 1.5 mm	1.5 - 2.0 mm
	Rating	√	∞	!	×	×
	End Mill					
	Diameter	0.1 - 1.0 mm	1.0 - 2.0 mm	2.0 - 3.5 mm	3.5 - 5.0 mm	5.0 - 6.0 mm
	Rating	√	√	!	×	×
Jig Grinding						
Rating	×					



625DT

Standard Equipment: 0.3 micron Combo Filter / Extractor, Spindle, 2 micron Ultra Precision ER 11 Collet System, Wrenches, Hose, Coolant Guard and Detachable Side NPT Fitting. Optional Collets 0.5 mm - 7 mm available.

625XDT Series

Make your Robodrill, Brother or Haas DT a high speed machine. Now you can get the speed needed for small tools and end frequent breakages. Airflow increases on demand to the double turbine **625XDT** delivering power to **0.76 hp (0.57 kW)** maintaining constant high speed at **30,000, 40,000, or 50,000 rpm** under cutting load. Speed and power combined optimize milling, drilling, engraving, slotting and finishing with small tools. You will materially reduce your cost per part with 6-10 x faster cycles and no duty cycle in 24/7 production.

PG-6 PowRgrip® collet optional for 0µ and rigidity; see specifications on page 19.

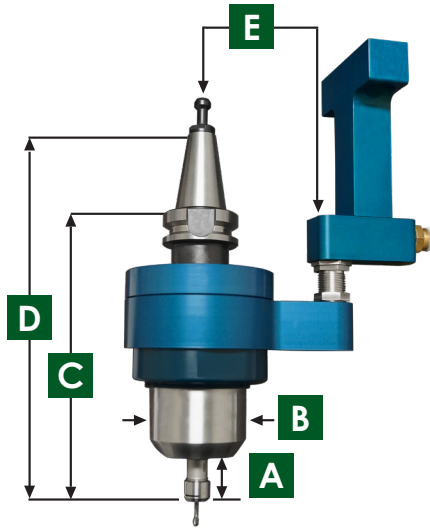

625XDT BT30 Shown

Dimensions

Many integrated shank dimensions (BT, CAT, DIN, ISO, HSK) available at www.airturbine-tools.com

BT30	
A	0.87" (22mm)
B	2.24" (57mm)
C	6.81" (173mm)
D	8.74" (222mm)
E	RoboDrill: 2.56" (65mm) • Brother TC: 3.58" (91mm) • Haas DT: 2.59" (66mm)

General Specifications

Governed Speed rpm	30,000 / 40,000 / 50,000
Power Rating hp (kW)	0.72 (0.54) / 0.74 (0.55) / 0.76 (0.57)
Inlet Air Pressure (clean dry air only)	90 PSI (6.2 Bar)
Air Consumption Idle cfm (l/s)	19 (8.97) / 20 (9.44) / 20 (9.44)
Air Consumption Working Flow cfm (l/s)	22 (10.38) - 30 (14.16)
Sound Level	Less Than 78 dBA
Max Shank Capacity	ER 11 - 1/4" (6mm)
Spindle Weight	96 oz (2.72 kg)
Coupling / Hose Min. Internal Diameter	0.31" (8mm)

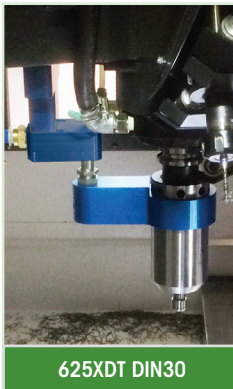

625XDT DIN30

Cutting Tool Guide

√ = Optimum

∞ = Acceptable

× = Not recommended for use

! = Dependent upon cutting conditions

Drill					
Diameter	0.1 - 0.3 mm	0.3 - 0.5 mm	0.5 - 1.0 mm	1.0 - 1.5 mm	1.5 - 2.0 mm
Rating	√	√	√	√	√
End Mill					
Diameter	0.1 - 1.0 mm	1.0 - 2.0 mm	2.0 - 3.5 mm	3.5 - 5.0 mm	5.0 - 6.0 mm
Rating	√	√	√	√	∞
Jig Grinding					
Rating	√				

Standard Equipment: 0.3 micron Combo Filter / Extractor, Spindle, 2 micron Ultra Precision ER 11 Collet System, Wrenches, Hose, Coolant Guard and Detachable Side NPT Fitting. Optional Collets 0.5 mm - 7 mm available.

DRILL TAP SPINDLES

602DT Series

At **65,000 rpm** in cut the compact **602DT** is a precise and reliable solution to increase your feed rates for 6 – 10 x. No duty cycle for 24/7 high speed production on your Robodrill, Brother or any Drill Tap machine. Your governed speed stays at **40,000, 50,000 or 65,000 rpm** in cut. With just 2 moving parts the 602DT Series is proven to reduce cycle times and optimize both tool performance and life. No control system or lubrication – just connect 90 PSI.

Dimensions

Many integrated shank dimensions (BT, CAT, DIN, ISO, HSK) available at www.airturbinetools.com

BT30	
A	0.72" (18mm)
B	1.56" (40mm)
C	4.71" (120mm)
D	6.52" (166mm)
E	RoboDrill: 3.16" (80mm) • Brother TC: 3.58" (91mm) • Haas DT: 2.56" (65mm)

General Specifications

Governed Speed rpm	40,000 / 50,000 / 65,000
Power Rating hp (kW)	0.15 (0.11) / 0.20 (0.15) / 0.20 (0.15)
Inlet Air Pressure (clean dry air only)	90 PSI (6.2 Bar)
Air Consumption Idle cfm (l/s)	4.5 (2.1) / 4.5 (2.1) / 4.5 (2.1)
Air Consumption Working Flow cfm (l/s)	5 (2.36) - 6(3.30)
Sound Level	Less Than 78 dBA
Max Shank Capacity	ER 11 - 1/8" (3mm)
Spindle Weight	35.3 oz (1 kg)
Coupling / Hose Min. Internal Diameter	0.25" (6.5mm)

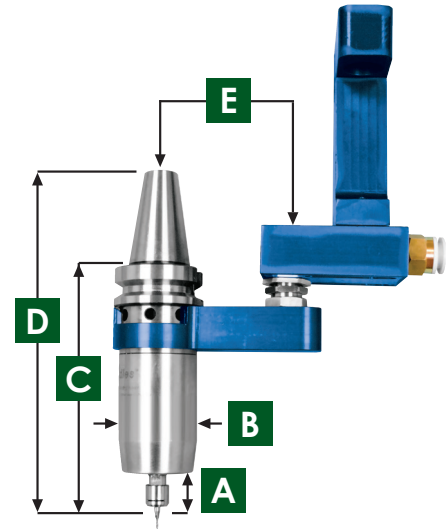

602DT BT30 Shown

Cutting Tool Guide

√ = Optimum ∞ = Acceptable × = Not recommended for use ! = Dependent upon cutting conditions	Drill					
	Diameter	0.1 - 0.3 mm	0.3 - 0.5 mm	0.5 - 1.0 mm	1.0 - 1.5 mm	1.5 - 2.0 mm
	Rating	√	∞	!	×	×
	End Mill					
	Diameter	0.1 - 1.0 mm	1.0 - 2.0 mm	2.0 - 3.5 mm	3.5 - 5.0 mm	5.0 - 6.0 mm
	Rating	√	√	!	×	×
	Jig Grinding					
	Rating	×				

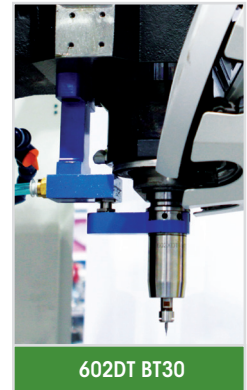

602DT BT30

Standard Equipment: 0.3 micron Combo Filter / Extractor, Spindle, 2 micron Ultra Precision ER 11 Collet System, Wrenches, Hose and Detachable Side NPT Fitting. - Optional Collets 0.5 mm - 4 mm available.

602 Series - "The Sprinter"

The 602 Series maintains governed constant high speeds under load - 40,000 to 90,000 rpm, < 0.20 hp (0.15 kW). This compact, direct drive spindle is engineered for high speed micro machining, ideal for engraving, milling, drilling and finishing with micro tools. Only 2 moving parts and air circulation over the bearings result in low heat and great reliability. Extended 100mm barrel option available, see page 18 for specifications.

BT, CAT, DIN, HSK and JS Straight Shank (3/4" / 20mm). Selectable rear or side air feed.

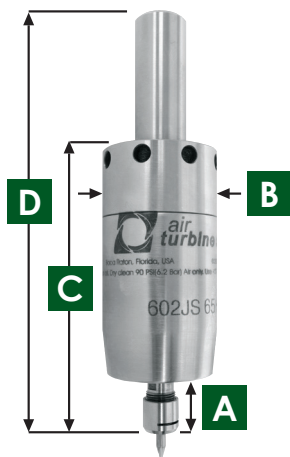

602JS Shown

Dimensions

Many integrated shank dimensions (BT, CAT, DIN, ISO, HSK) available at www.airturbinetools.com

	JS	HSK-A63	CAT40
A	0.76" (19mm)	0.76" (19mm)	0.76" (19mm)
B	1.56" (40mm)	1.56" (40mm)	1.56" (40mm)
C	3.75" (95mm)	5.55" (141mm)	6.06" (154mm)
D	5.75" (146mm)	6.69" (170mm)	8.74" (222mm)

General Specifications

Governed Speed rpm	40,000 / 50,000 / 65,000 / *90,000
Power Rating hp (kW)	0.15 (0.11) / 0.2 (0.15) / 0.2 (0.15) / 0.2 (0.15)
Inlet Air Pressure (clean dry air only)	90 PSI (6.2 Bar)
Air Consumption Idle cfm (l/s)	4.5 (2.1) / 4.5 (2.1) / 4.5 (2.1) / 5 (2.4)
Air Consumption Working Flow cfm (l/s)	5 (2.36) - 6 (3.30)
Sound Level	Less Than 78 dBA
Max Shank Capacity	ER 8 - 1/8" (3mm)
Spindle Weight	JS: 23.2 oz (0.66 kg) • CAT/DIN/BT/HSK: 46.4 oz (1.32 kg)
Coupling / Hose Min. Internal Diameter	0.25" (6.5mm)

*Due to its governed high speed and power the 602 90,000 rpm is only for use with micro end mills in special applications

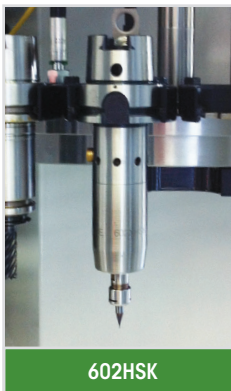

602HSK

602 Cutting Tool Guide

√ = Optimum

∞ = Acceptable

× = Not recommended for use

! = Dependent upon cutting conditions

Drill					
Diameter	0.1 - 0.3 mm	0.3 - 0.5 mm	0.5 - 1.0 mm	1.0 - 1.5 mm	1.5 - 2.0 mm
Rating	√	∞	!	×	×
End Mill					
Diameter	0.1 - 1.0 mm	1.0 - 2.0 mm	2.0 - 3.5 mm	3.5 - 5.0 mm	5.0 - 6.0 mm
Rating	√	√	!	×	×
Jig Grinding					
Rating	×				

Standard Equipment: 0.3 micron Combo Filter / Extractor, Spindle, 2 micron Ultra Precision ER 8 Collet System, Wrenches, Hose and Detachable Side NPT Fitting. Optional Collets 0.5 mm - 4 mm available.

650X Series - "The Workhorse - with Extra Power"

Get nonstop power and precision with the double turbine **650X Series - 25,000 to 40,000 rpm, < 1.40 hp (1.04 kW)**. The patented governor controlled high power **650X Series** maintains constant high speed for trochoidal milling in hard materials and cuts your cycle times dramatically. The ceramic bearings, cooled by turbine air, make this spindle robust and reliable. Mill 24/7 with No Duty Cycle and No Thermal Expansion. Eliminates secondary finishing. BT, CAT, DIN, HSK and JS Straight Shank (3/4" / 20mm). For switchable 25,000/ 40,000 rpm see Variable Speed 650XVS specifications on page 16.

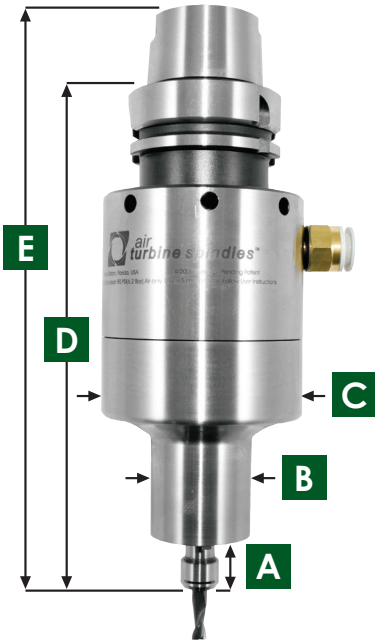

650XHSK-A63 Shown

Dimensions

Many integrated shank dimensions (BT, CAT, DIN, ISO, HSK) available at www.airturbinetools.com

	JS	HSK-A63	CAT40
A	0.87" (22mm)	0.87" (22mm)	0.87" (22mm)
B	1.63" (41mm)	1.63" (41mm)	1.63" (41mm)
C	3.23" (82mm)	3.23" (82mm)	3.23" (82mm)
D	6.26" (159mm)	8.23" (209mm)	7.68" (195mm)
E	8.23" (209mm)	9.13" (232mm)	10.40" (263mm)

General Specifications

Governed Speed rpm	25,000 / 30,000 / 40,000
Power Rating hp (kW)	1.2 (0.90) / 1.3 (0.98) / 1.4 (1.04)
Inlet Air Pressure (clean dry air only)	90 PSI (6.2 Bar)
Air Consumption Idle cfm (l/s)	16 (7.56) / 17 (8.02) / 18 (8.49)
Air Consumption Working Flow cfm (l/s)	19 (8.97) - 40 (18.89)
Sound Level	Less Than 78 dBA
Max Shank Capacity	ER 11 - 1/4" (6mm)
Spindle Weight	JS: 75.2 oz (2.13 kg) • CAT/DIN/BT/HSK: 118.4 oz (3.34 kg)
Coupling / Hose Min. Internal Diameter	0.39" (10mm)

660 Series - "The Titan"

The 660 Series features higher governed constant speed at **50,000 rpm** and power at **0.94 hp (0.70 kW)**. Mill faster in all materials, including tool steel, titanium and ceramics, reducing your cycle times dramatically. No change in tool length and spindle temperature was recorded in independent testing over 12 hours at 50,000 rpm. For use with small tools milling hard materials with a light pass the 660 Series large grease packed air cooled ceramic bearings assure reliability. BT, CAT, DIN, HSK and JS Straight Shank (3/4" / 20mm).

General Specifications	
Governed Speed rpm	50,000
Power Rating hp (kW)	0.94 (0.70)
Inlet Air Pressure (clean dry air only)	90 PSI (6.2 Bar)
Air Consumption Idle cfm (l/s)	14 (6.61)
Air Consumption Working Flow cfm (l/s)	14 (6.60) - 35 (16.5)
Sound Level	Less Than 78 dBA
Max Shank Capacity	ER 11 - 1/4" (6mm)
Spindle Weight	JS: 65.8 oz (1.95 kg) • CAT/DIN/BT/HSK: 112.8 oz (3.20 kg)
Coupling / Hose Min. Internal Diameter	0.31" (8mm)

Dimensions	
	JS
A	0.87" (22mm)
B	1.63" (41mm)
C	3.23" (82mm)
D	5.79" (147mm)
E	7.76" (197mm)

Many integrated shank dimensions (BT, CAT, DIN, ISO, HSK) available at www.airturbinetools.com

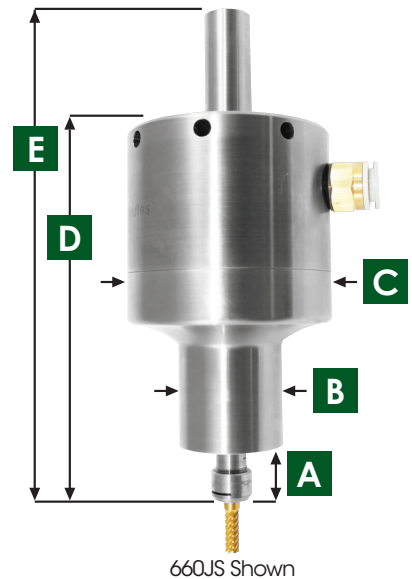

660JS Shown

650 Series - "The Workhorse"

The **650 Series** delivers governed constant high speeds under load - **25,000 to 40,000 rpm, < 0.88 hp (0.66 kW)**.

Robust and reliable, with double front ceramic bearings, the **650 Series** is ideal for heavier duty applications and milling hard materials in corners. The governor controlled turbine maintains rated high speed, optimizing tool performance and life. Effective in all materials, including tool steel, titanium and ceramic. Ultra low vibration and no heat in 24/7 operation.

BT, CAT, DIN, HSK and JS Straight Shank (3/4" / 20mm).

For switchable 25,000/ 40,000 rpm see Variable Speed 650XVS specifications on page 16.

Dimensions

Many integrated shank dimensions (BT, CAT, DIN, ISO, HSK) available at www.airturbinetools.com

	JS	HSK-A63	CAT40
A	0.87" (22mm)	0.87" (22mm)	0.87" (22mm)
B	1.63" (41mm)	1.63" (41mm)	1.63" (41mm)
C	3.23" (82mm)	3.23" (82mm)	3.23" (82mm)
D	5.79" (147mm)	7.76" (197mm)	7.20" (183mm)
E	7.76" (197mm)	8.66" (220mm)	9.88" (251mm)

General Specifications

Governed Speed rpm	25,000 / 30,000 / 40,000
Power Rating hp (kW)	0.80 (0.60) / 0.83 (0.62) / 0.88 (0.66)
Inlet Air Pressure (clean dry air only)	90 PSI (6.2 Bar)
Air Consumption Idle cfm (l/s)	13 (6.1) / 14 (6.6) / 14 (6.6)
Air Consumption Working Flow cfm (l/s)	14 (6.60) - 35 (16.5)
Sound Level	Less Than 78 dBA
Max Shank Capacity	ER 11 - 1/4" (6mm)
Spindle Weight	JS: 65.8 oz (1.95 kg) • CAT/DIN/BT/HSK: 112.8 oz (3.20 kg)
Coupling / Hose Min. Internal Diameter	0.31" (8mm)

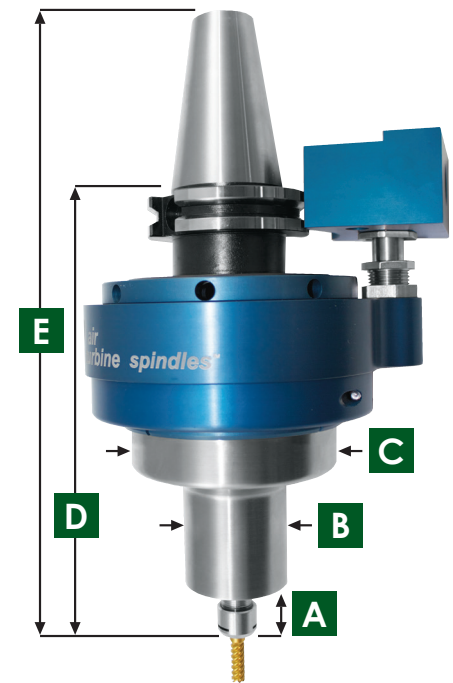

650CAT40 Shown

650(X) + 660 Cutting Tool Guide

<p>√ = Optimum</p> <p>∞ = Acceptable</p> <p>× = Not recommended for use</p> <p>! = Dependent upon cutting conditions</p>	Drill					
	Diameter	0.1 - 0.3 mm	0.3 - 0.5 mm	0.5 - 1.0 mm	1.0 - 1.5 mm	1.5 - 2.0 mm
	Rating	√	√	√	√	√
	End Mill					
	Diameter	0.1 - 1.0 mm	1.0 - 2.0 mm	2.0 - 3.5 mm	3.5 - 5.0 mm	5.0 - 6.0 mm
	Rating	√	√	√	√	∞
	Jig Grinding					
	Rating	√				

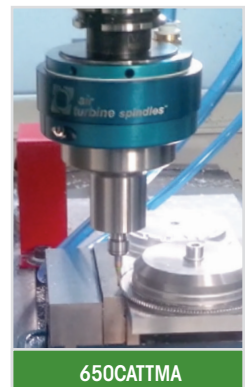

650CAT40

Standard Equipment: 0.3 micron Combo Filter / Extractor, Spindle, 2 micron Ultra Precision ER 11 Collet System, Wrenches, Hose, Coolant Guard and Detachable Side NPT Fitting. Optional Collets 0.5 mm - 7 mm available.

HIGH SPEED SPINDLES

625X Series - "The All-Rounder - with Extra Power"

The patented double turbine. **625X Series** delivers constant high speeds under load - **30,000 to 50,000 rpm, < 0.76 hp (0.57 kW)**. Speed up your cycle times with this compact and powerful spindle. Ideal for contouring, mold making, milling, and finishing. Governor control maintains constant high speed and power under load.

For heavier applications consider the **650 Series** with high torque and double front bearings.

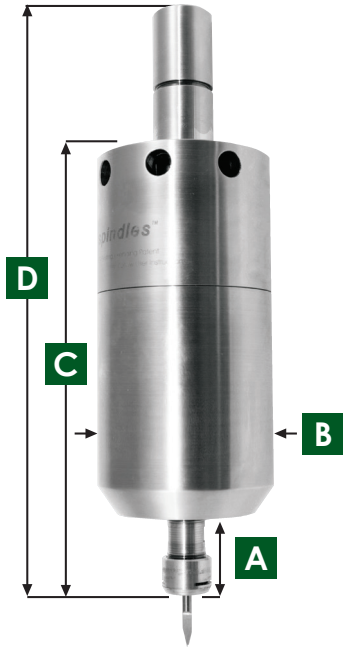

625XJS Shown

Dimensions

Many integrated shank dimensions (BT, CAT, DIN, ISO, HSK) available at www.airturbinetools.com

	JS	HSK-A63	CAT40
A	0.87" (22mm)	0.87" (22mm)	0.87" (22mm)
B	2.24" (57mm)	2.24" (57mm)	2.24" (57mm)
C	5.55" (141mm)	6.50" (165mm)	6.85" (174mm)
D	7.52" (191mm)	7.56" (192mm)	9.57" (243mm)

General Specifications

Governed Speed rpm	30,000 / 40,000 / 50,000
Power Rating hp (kW)	0.72 (0.54) / 0.74 (0.55) / 0.76 (0.57)
Inlet Air Pressure (clean dry air only)	90 PSI (6.2 Bar)
Air Consumption Idle cfm (l/s)	19 (8.97) / 20 (9.44) / 20 (9.44)
Air Consumption Working Flow cfm (l/s)	22 (10.38) - 30 (14.16)
Sound Level	Less Than 78 dBA
Max Shank Capacity	ER 11 - 1/4" (6mm)
Spindle Weight	JS: 64 oz (1.81 kg) • CAT/DIN/BT/HSK: 96 oz (2.72 kg)
Coupling / Hose Min. Internal Diameter	0.31" (8mm)

625X90 Series - "The 90 Degree - with Extra Power"

The motor is in the 90° head on our unique **625X90**. This one piece patented design reduces the height of the spindle and gives you rigidity. The **625X90** is a direct drive with no gears or HF brushes to vibrate or burn up in other 90° spindles. This 90° spindle mills and drills with no heat - improving accuracy and reliability.

Reach into angles and pockets, or mill laterally, with a 50 mm extended barrel option to reach tight spaces. Double turbine power gives you **0.76 hp (0.57Kw)** maintaining rated **30,000, 40,000, or 50,000 rpm** on your tool path. Load manually or integrate automated loading on any CNC.

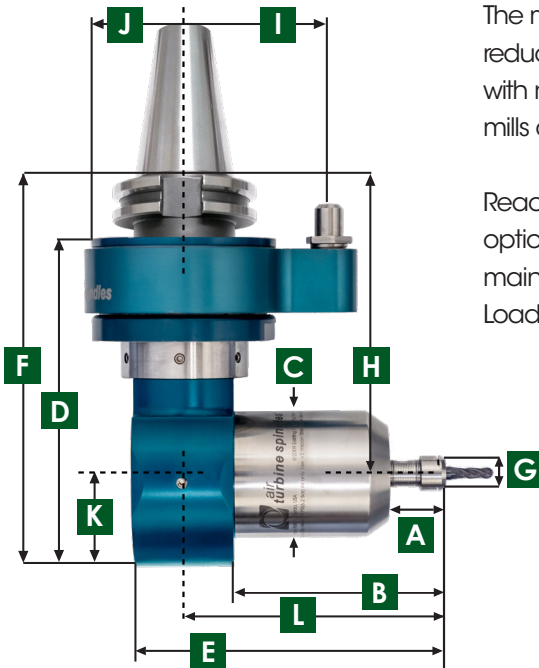

625X90CAT40 Shown with TMA Assembly installed

Dimensions

CAT40

A	0.96 (24.4mm)	G	0.63" (16.0 mm)
B	3.67" (93.2mm)	H	5.42" (137.6mm)
C	2.25" (57.2mm)	I	2.56" (65.0mm)
D	5.79" (147.1 mm)	J	1.75" (44.5mm)
E	5.41" (137.3 mm)	K	1.62" (41.1mm)
F	7.04" (178.9 mm)	L	4.54" (115.3mm)



625X90CAT40 + TMA

625 Series - "The All-Rounder"

The versatile and reliable **625 Series** delivers governed constant high speeds under load - **30,000 to 65,000 rpm**, **< 0.55 hp (0.41 kW)**. Ideal for mold making, milling and finishing with small tools up to 1/4" / 6mm capacity. Only 2 moving parts and air circulation over the bearings, result in low heat. Get the reliability of direct drive milling with no duty cycle and no thermal expansion. BT, CAT, DIN, HSK, and JS Straight Shank (3/4" / 20mm). Selectable rear or side air feed.

Ultra Precision Option: PG-6 PowRgrip® collet for 0µ and rigidity. See specifications on page 19.

For switchable 30,000/ 50,000 rpm see Variable Speed 625XVS specifications on page 15.

Dimensions

Many integrated shank dimensions (BT, CAT, DIN, ISO, HSK) available at www.airturbinetools.com

	JS	HSK-A63	CAT40
A	0.87" (22mm)	0.87" (22mm)	0.87" (22mm)
B	2.24" (57mm)	2.24" (57mm)	2.24" (57mm)
C	5.12" (130mm)	6.06" (154mm)	6.42" (163mm)
D	7.09" (180mm)	7.13" (181mm)	9.13" (232mm)

General Specifications

Governed Speed rpm	30,000 / 40,000 / 50,000 / 65,000
Power Rating hp (kW)	0.40 (0.30) / 0.45 (0.34) / 0.50 (0.37) / 0.55 (0.41)
Inlet Air Pressure (clean dry air only)	90 PSI (6.2 Bar)
Air Consumption Idle cfm (l/s)	10.5 (4.9) / 11 (5.2) / 11 (5.2) / 11 (5.2)
Air Consumption Working Flow cfm (l/s)	11 (5.2) - 20 (9.4)
Sound Level	Less Than 78 dBA
Max Shank Capacity	ER 11 - 1/4" (6mm)
Spindle Weight	JS: 49.6 oz (1.41 kg) • CAT/DIN/BT/HSK: 81.6 oz (2.31 kg)
Coupling / Hose Min. Internal Diameter	0.25" (6.5mm)

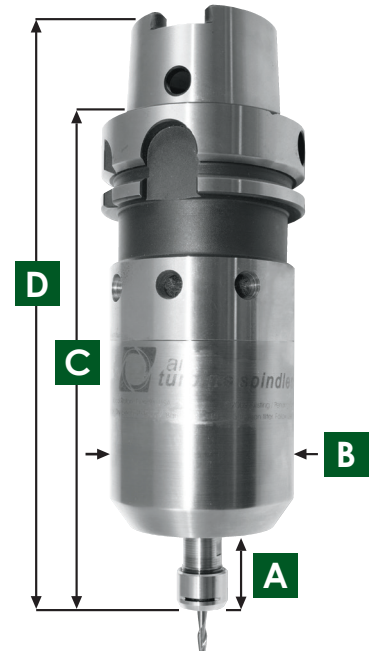

625HSK-A63 Shown

625(X) Cutting Tool Guide

√ = Optimum ∞ = Acceptable × = Not recommended for use ! = Dependent upon cutting conditions	Drill					
	Diameter	0.1 - 0.3 mm	0.3 - 0.5 mm	0.5 - 1.0 mm	1.0 - 1.5 mm	1.5 - 2.0 mm
	Rating	√	√	√	∞	!
	End Mill					
	Diameter	0.1 - 1.0 mm	1.0 - 2.0 mm	2.0 - 3.5 mm	3.5 - 5.0 mm	5.0 - 6.0 mm
	Rating	√	√	√	∞	!
	Jig Grinding					
	Rating	!				



625CAT TMA

Standard Equipment: 0.3 micron Combo Filter / Extractor, Spindle, 2 micron Ultra Precision ER 11 Collet System, Wrenches, Hose, Coolant Guard and Detachable Side NPT Fitting. Optional Collets 0.5 mm - 7 mm available.

VARIABLE SPEED SPINDLES

625XVS Series

Switch speed and power in moments. The **625XVS** has a governor control that maintains constant high speed and power under load. Direct drive means low heat, no duty cycle, and super reliability. Insert a hex key through the rear of the spindle switches the position of an internal screw – controlling the flow of compressed air to supply one or both turbines **operating at different speeds with single or double turbine power ratings.**

30,000 rpm 0.4 hp (0.30 kW) in single turbine mode and **50,000 RPM 0.76 hp (0.57 kW) in twin-turbine mode**
BT, CAT, DIN, HSK and JS Straight Shank (3/4" / 20mm). Selectable rear or side air feed.

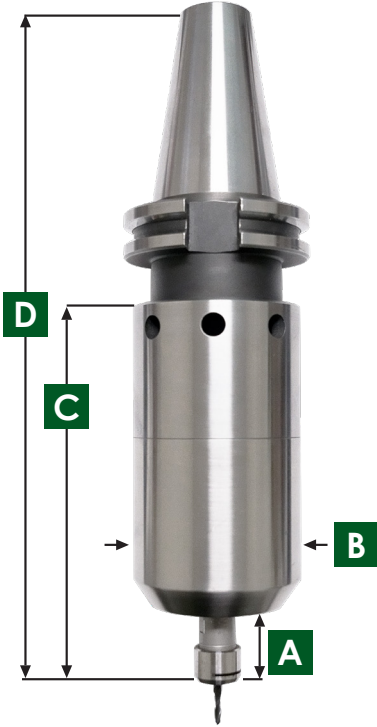

625XVSCAT40 Shown

Dimensions

Many integrated shank dimensions (BT, CAT, DIN, ISO, HSK) available at www.airturbinetools.com

	JS	HSK-A63	CAT40
A	0.87" (22mm)	0.87" (22mm)	0.87" (22mm)
B	2.24" (57mm)	2.24" (57mm)	2.24" (57mm)
C	5.55" (141mm)	6.50" (82mm)	6.85" (174mm)
D	7.52" (192mm)	7.56" (192mm)	9.57" (243mm)

General Specifications

Governed Speed rpm	30,000 – 50,000
Power Rating hp (kW)	0.40 (0.30) – 0.76 (0.57)
Inlet Air Pressure (clean dry air only)	90 PSI (6.2 Bar)
Air Consumption Idle cfm (l/s)	10.5 (4.9) – 20 (9.44)
Air Consumption Working Flow cfm (l/s)	11 (5.2) – 30 (14.16)
Sound Level	Less Than 78 dBA
Max Shank Capacity	ER 11 - 1/4" (6mm)
Spindle Weight	JS: 60 oz (1.70 kg) • CAT/DIN/BT/HSK: 96 oz (2.72 kg)
Coupling / Hose Min. Internal Diameter	0.31" (8mm)

Our patent-pending system makes it very easy to change speed and power rating in a minute with our patented double turbine. A hex key fits through the air shaft at the back of the spindle. The flow control screw is turned up or down by the hex key to switch speeds, as displayed below in the red and green positions below.

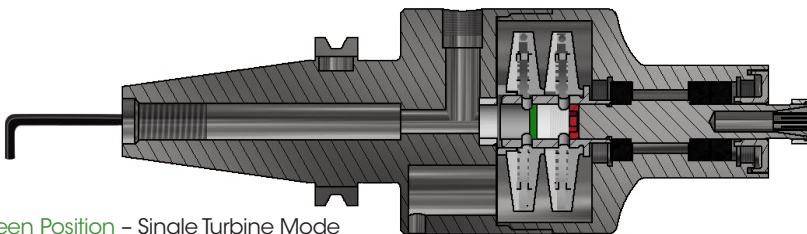

Green Position – Single Turbine Mode

Red Position – Double Turbine Mode

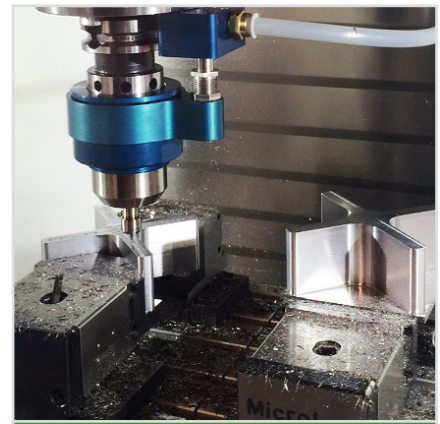

625XVS + TMA

Standard Equipment: 0.3 micron Combo Filter / Extractor, Spindle, 2 micron Ultra Precision ER 11 Collet System, Wrenches, Hose, Coolant Guard and Detachable Side NPT Fitting. Optional Collets 0.5 mm - 7 mm available.

650XVS Series

The **650XVS** Series accelerates feed rates and cuts cycle times as a result of its low friction power unit with few moving parts. Change power and governed speed with a hex key between **25,000 to 40,000 rpm**. Up to **1.4 hp** to speed up your inches cut per minute. Double front ceramic bearings, cooled by turbine air, make this spindle robust and reliable. Mill 24/7 with No Duty Cycle and No Thermal Expansion. Eliminates secondary finishing. See specifications on page 11.

25,000 rpm 0.8 hp (0.60 kW) in single turbine mode and **40,000 RPM 1.4 hp (1.04 kW) in twin-turbine mode**
BT, CAT, DIN, HSK and JS Straight Shank (3/4" / 20mm).

For optional extended reach see 100mm Extended Barrel 650XL Series specifications on page 18.

Dimensions

Many integrated shank dimensions (BT, CAT, DIN, ISO, HSK) available at www.airturbinetools.com

	JS	HSK-A63	CAT40
A	0.87" (22mm)	0.87" (22mm)	0.87" (22mm)
B	3.23" (82mm)	3.23" (82mm)	3.23" (82mm)
C	6.26" (82mm)	8.23" (209mm)	7.68" (195mm)
D	8.23" (209mm)	9.13" (197mm)	10.4" (263mm)

General Specifications

Governed Speed rpm	25,000 – 40,000
Power Rating hp (kW)	0.8 (0.60) – 1.4 (1.04)
Inlet Air Pressure (clean dry air only)	90 PSI (6.2 Bar)
Air Consumption Idle cfm (l/s)	11 (5.2) – 18 (8.49)
Air Consumption Working Flow cfm (l/s)	14 (6.60) – 40 (18.89)
Sound Level	Less Than 78 dBA
Max Shank Capacity	ER 11 - 1/4" (6mm)
Spindle Weight	JS: 75.2 oz (2.13 kg) • CAT/DIN/BT/HSK: 118.4 oz (3.34 kg)
Coupling / Hose Min. Internal Diameter	0.39" (10mm)

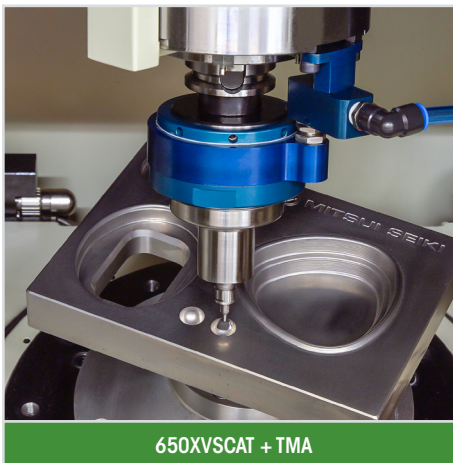
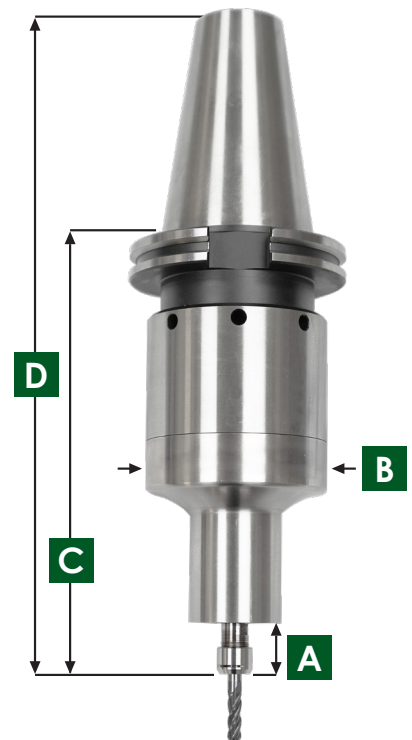

Standard Equipment: 0.3 micron Combo Filter / Extractor, Spindle, 2 micron Ultra Precision ER 11 Collet System, Wrenches, Hose, Coolant Guard and Detachable Side NPT Fitting. Optional Collets 0.5 mm - 7 mm available.

EXTENDED BARREL SPINDLES

625L Series - "The Super Model"

50mm and 100mm Extended Barrels

The **625L (50mm) Series** delivers governed constant high speeds under load - **30,000 to 50,000 rpm, < 0.5 hp (0.37 kW)**. This reliable multipurpose spindle, with its 50mm length body, is ideal for mold making, milling and finishing with small cutter capacities in deep pockets. See specifications for the 625 series on page 14.

BT, CAT, DIN, HSK and JS Straight Shank (3/4" / 20mm). Double front bearings standard.
For switchable 25,000/ 40,000 rpm see Variable Speed 625XVS specifications on page 15.

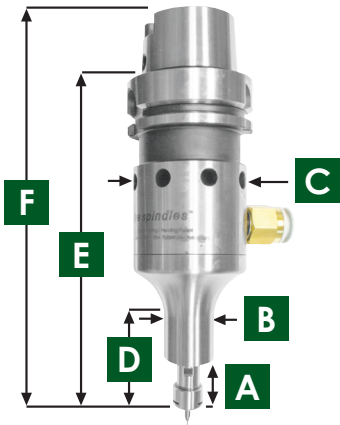

625LHSK-A63 (50mm) Shown

Dimensions			
Many integrated shank dimensions (BT, CAT, DIN, ISO, HSK) available at www.airturbinetools.com			
	JS	HSK-A63	CAT40
A	1.00" (25mm)	1.00" (25mm)	1.00" (25mm)
B	1.00" (25mm)	1.00" (25mm)	1.00" (25mm)
C	2.25" (57mm)	2.25" (57mm)	2.25" (57mm)
D	2.16" (55mm)	2.16" (55mm)	2.16" (55mm)
E	5.22" (133mm)	6.97" (177mm)	6.65" (169mm)
F	7.22" (183mm)	8.03" (204mm)	9.36" (238mm)

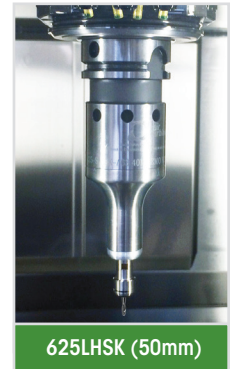

625LHSK (50mm)

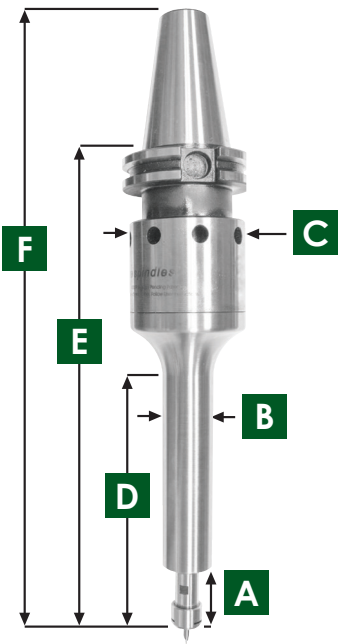

625LCAT40 (100mm) Shown

The long body **625L (100mm) Series** delivers governed constant high speeds under load - **30,000 to 50,000 rpm, < 0.50 hp (0.37 kW)**. Speed up your cycle times with this compact and powerful spindle. Ideal for contouring, mold making, milling, finishing and drilling with small tools in deep pockets.
Governor control maintains constant high speed and power under load.

BT, CAT, DIN, HSK and JS Straight Shank (3/4" / 20mm).
Selectable rear or side airfeed. Double front bearings standard.

Dimensions			
Many integrated shank dimensions (BT, CAT, DIN, ISO, HSK) available at www.airturbinetools.com			
	JS	HSK-A63	CAT40
A	1.00" (25mm)	1.00" (25mm)	1.00" (25mm)
B	1.00" (25mm)	1.00" (25mm)	1.00" (25mm)
C	2.25" (57mm)	2.25" (57mm)	2.25" (57mm)
D	4.80" (122mm)	4.80" (122mm)	4.80" (122mm)
E	7.86" (200mm)	9.61" (244mm)	9.29" (236mm)
F	9.86" (250mm)	10.67" (271mm)	12" (305mm)



625LCAT (100mm)

Standard Equipment: 0.3 micron Combo Filter / Extractor, Spindle, 2 micron Ultra Precision ER 11 Collet System, Wrenches, Hose, Coolant Guard and Detachable Side NPT Fitting. Optional Collets 0.5 mm - 7 mm available.

650L + 650XL Series - "The Body Builder"

100mm Extended Barrels

The robust, long body **650L (100mm) Series** delivers governed constant high speed and power under load - **25,000 to 40,000 rpm, < 0.88 hp (0.66 kW)** with double front ceramic bearings. The **650L (100mm) Series** is ideal for heavier duty applications and milling hard materials in corners in deep pockets. Where extra power is needed in hard materials or deeper cuts the extended **650XL (100mm) Series** delivers our patented double turbine power **1.40 hp (1.04 kW)**. See specifications for the 650 and 650X series on pages 12 and 11.

BT, CAT, DIN, HSK and JS Straight Shank (3/4" / 20mm).

For switchable 25,000/ 40,000 rpm see Variable Speed 650XVS specifications on page 16.

Dimensions			
Many integrated shank dimensions (BT, CAT, DIN, ISO, HSK) available at www.airturbinetools.com			
	JS	HSK-A63	CAT40
A	0.99" (25mm)	0.99" (25mm)	0.99" (25mm)
B	1.62" (41mm)	1.62" (41mm)	1.62" (41mm)
C	3.23" (82mm)	3.23" (82mm)	3.23" (82mm)
D	5.59" (142mm)	5.59" (142mm)	5.59" (142mm)
E	8.22" (209mm) (X) 8.72" (221mm)	9.99" (254mm) (X) 10.49" (266mm)	9.59" (244mm) (X) 10.09" (256mm)
F	10.24" (260mm) (X) 10.74" (273mm)	11.14" (283mm) (X) 11.64" (296mm)	12.34" (313mm) (X) 12.84" (326mm)

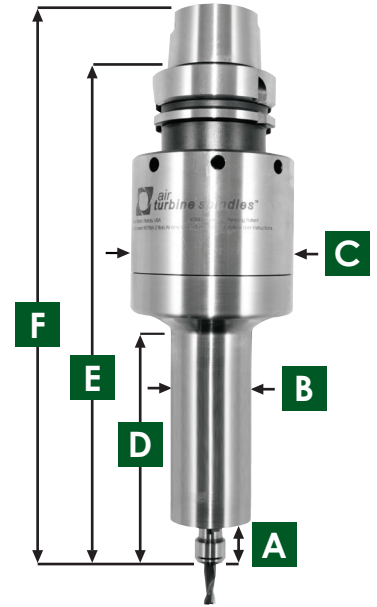

650L HSK-A63 (100mm) Shown

602L Series - "The Deep Diver"

100mm Extended Barrels

The compact, direct-drive **602L (100mm)** is engineered for high-speed micro machining. Suitable for engraving, edge milling and finishing with micro tools in deep pockets and concave molds with its 100mm long body.

Governed **40,000 to 90,000 rpm, < 0.2 hp (0.15 kW)**.

See specifications for the 602 series on page 10.

**Due to its governed high speed and power the 602 90,000 rpm is only for use with micro end mills in special applications*

Dimensions			
Many integrated shank dimensions (BT, CAT, DIN, ISO, HSK) available at www.airturbinetools.com			
	JS	HSK-A63	CAT40
A	0.81" (22mm)	0.76" (19mm)	0.81" (22mm)
B	1.56" (40mm)	1.56" (40mm)	1.56" (40mm)
C	6.59" (167mm)	9.18" (233mm)	8.91" (226mm)
D	8.59" (218mm)	10.44" (265mm)	11.59" (294mm)

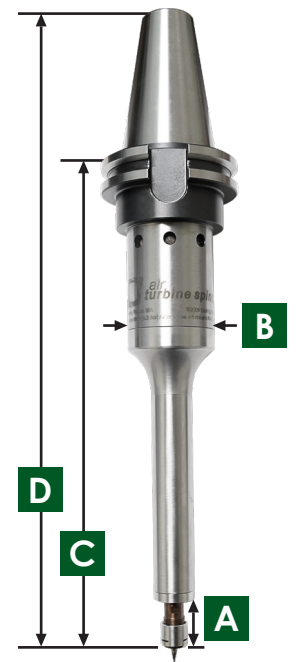

602L CAT40 (100mm) Shown

Standard Equipment: 0.3 micron Combo Filter / Extractor, Spindle, 2 micron Ultra Precision ER 11 Collet System, Wrenches, Hose, Coolant Guard and Detachable Side NPT Fitting. Optional Collets 0.5 mm - 7 mm available.

Press-Fit Series - "Rigid Ultra Precision"

Both Power or Manual Clamping Options ensure correct clamping diameter and T.I.R on every tool change. The resultant high torque transmission extends tool life. The powRgrip option dampens the already low vibration of the direct drive.



Automatic clamping Unit



PG collet



Manual clamping Unit



625HSK - PT



Our Press-Fit Collet System locks in runout stability in collet at TIR $\leq 2 \mu\text{m}$ and TIR $\leq 3 \mu\text{m}$ at 3 x D.

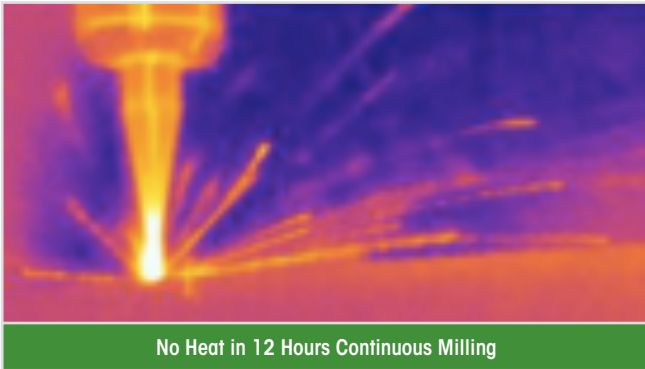

No Heat in 12 Hours Continuous Milling

Extend Tool Life and Improve RA Surface

Eliminate problems thermal growth of your spindle resulting in problems with accuracy: no change in tool length and spindle temperature was recorded in independent testing at 50,000 rpm. Available on the 625 and 650 Spindles with speeds from **25,000 rpm to 65,000 rpm**.

See specifications on pages 14 and 12.

BT, CAT, DIN, HSK and JS Straight Shank (3/4" / 20mm).

Selectable rear or side air feed.

ER11 Collet Length VS PG6 Collet Length

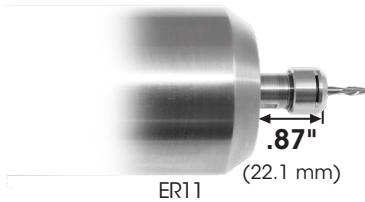

ER11

(22.1 mm)

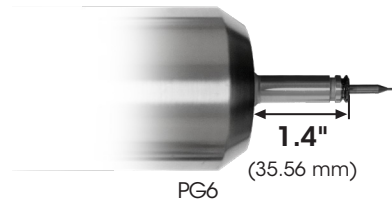

PG6

(35.56 mm)

Advantages of PG6

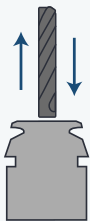

Maximum Clamping Force and Lowest Runout



Ready to use in 10 Seconds



Vibration Dampening and Rigidity

Standard Equipment: 0.3 micron Combo Filter / Extractor, Spindle, 2 micron Ultra Precision ER 11 Collet System, Wrenches, Hose and Detachable Side NPT Fitting. Optional Collets 0.5 mm - 7 mm available.

Tool Changer Mounting Assembly

Automatically load Air Turbine Spindles® in CNC machines with our patented wrap-around Toolchanger Mounting Assembly (TMA). This ATC option automatically loads/unloads our family of high-speed precision spindles using a proprietary collar system and air supply mounting block or ring at the right side of the CNC spindle. Set-up takes only minutes. Your spindle can rotate at low speed inside the TMA collar for probe operation.

The TMA block remains on the CNC spindle for normal tool changes when the Air Turbine Spindle is not in use as it will not interfere with your normal static tooling when using the main spindle.

Standard blocks and collars are supplied for Haas, Hurco, Robodrill, Brother, Doosan, DMG, Romi, Mazak and most other CNC's are available. If you supply non-standard CNC spindle dimensions we can make supply a custom fit quickly.

TMA Assembly Includes:

Mounting block assembly or Collar depending matching your CNC design. Spindle manifold collar with adjustable height connector to air supply connector block and ball-check valve.

Note: Air Turbine Spindles® TMA option is not required on VMC's where air in the CNC can be used to supply sufficient CFM / L/S airflow.

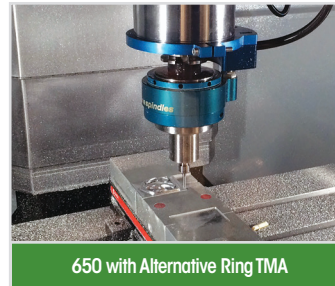

Tool Breakage Alarm System™ - Avoid Hours of Down Time

As your tool follows the programed tool path our broken tool detector system monitors CFM flow for deviation from a sensitive baseline of record of compressed air consumption. If your cutting tool breaks our Tool Breakage Alarm System™ activates to alert the operator with a light and/or a klaxon. Intervention limits damage to your parts and spindles and reduces loss of production yield.

Drops in air pressure or CFM flow will destroy your part and tool. Now you can detect airflow cavitation to your spindle or motor whether from the diversion to other machines or compressor malfunctions. Monitoring airflow against the recorded baseline assures you consistent operation through your programs and mitigates risk to your work in process and machine.



Tool Breakage Alarm System™

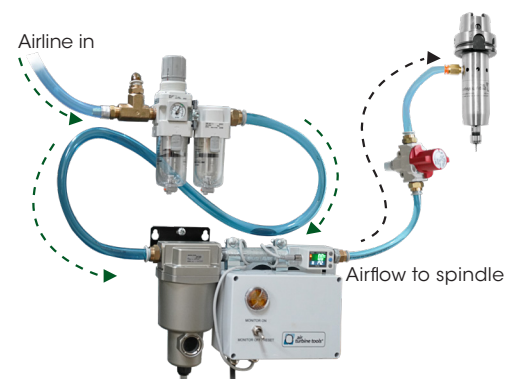

System Monitor Diagram

Quick Spindle User Notes

- A dedicated clean airline is required to supply air to the spindle. Ensure Air Supply is turned off before installing your spindle and the Machine door is shut before switching on Air Supply. Unrestricted air flow is essential at 90 psi (6.2 bar) pressure and the specified CFM/ L/S flow rate for full power performance. A filter extractor is supplied as Standard Equipment. Avoid using lubricant contaminated hoses which can result in oil in the motor.

- Ensure you have a concentric balanced speed rated end mill by consulting manufacturer's speed and feeds / depth of cut recommendations. Securely tighten the end mill in the Spindle collet. The more flutes the better (eg 4 or 6) you will evacuate chips, reduce wear per tooth and reduce heat.

- Turn off lubrication to main spindle, if recommended by your machine manufacturer. Remember to program for resumption of flow when main spindle resumes rotation. When an Air Turbine Spindle is mounted, ensure Machine Spindle is at "0" rotation at all times and for your machine spindle to advance without rotating.

- To automate the loading of your Air Turbine Spindles® use rear air inlet (displayed blow) or our patented Toolchanger Mounting Assembly (comprising a collar connecting to a mounting block). Standard and customized assemblies are available for any CNC. The block is either mounted on ring around the CNC spindle or screwed in to the holes in the main spindle. Screw holes are pre-drilled for your machine's screw pattern or can be drilled by the CNC user in the required positions in the universal mounting block. Check clearance of autoloading cycle in to the CNC magazine. The connector air plug from the TMA Spindle collar is adjustable for height to fit the dimension between the collar and the air connector block.

- On Integrated Tool Holder models each machine manufacturer specifies the retention knob for CAT, BT or DIN (SK) configurations. Air Turbine Spindles® are available with metric and inch size screw threads.

- Follow normal procedures to zero the offset for your spindle when mounted in your machine. Air Turbine Spindles® has an offsetting procedure available upon request. Certificate of conformity states offset.

- If your CNC has air feed through the spindle it can be used on the 602 / 625 units or HSK units after channel used is cleaned by a purge. The channel internal diameter for its full length must be greater than $\frac{1}{4}$, 6.5mm so that sufficient airflow CFM (L/S) can pass. Some pull plugs allow sufficient airflow to pass, or your plug can be drilled. However, 625X, 650, 660 HSK units require a minimum $\frac{3}{8}$, 8mm I'D on the channel and on all couplings to avoid flow restrictions.

- Your spindle has 2 air inlets (rear + side) as shown to the right. Ensure the inlet not in use is closed. If you hear a loud noise or have under rated power performance check if the plug is in the second inlet.

- All HSK Spindles can receive center air feed from clean coolant channels of sufficient internal diameter to allow specified airflow to pass and auto change using a solenoid and the coolant channel connector tube. Purge the channel so clean airflow passes. Ensure no small couplings constrict airflow. Check airflow against specification with a flow meter.

- Coolant or air may be directed at the cutting tip of your end mill but coolant should not flood or ride up to the body of your spindle. Program to switch off coolant jets before the air flow.

- Air Turbine Spindles® must be run at least 10 minutes every 30 days from manufacture date to maintain optimal performance. Run spindle at least 10 minutes before initial use.



625HSK-A63

Hose / Fitting / Connector Specifications

Minimum 90 psi (6.2 bar) clean air pressure. (Okay to adjust up to 100 psi (6.9 bar) at regulator in line to your spindle, as psi / bar air pressure will vary and drop under idle/working load). Do not exceed 100 psi (7 bar).

Hose / Fitting / Connector Internal Diameter Specifications

Models	Minimum Internal Diameter
602, and 625 spindles	0.25" (6.5mm)
625X, 650, 660 spindles and 602, 625, 625X, 650 and 660 spindles with TMA	0.31" (8mm)
650X Spindles and 650X spindles with TMA	0.39" (10mm)

Ensure hoses and connectors meet minimum dimensions to avoid airflow restrictions.

General Air Fitting Dimensions

Inch Quick Disconnect type fitting (shop air type) Overview:

- 1/4" Male > ID = Usually 0.210" but some variations occur.
- 1/4" Male (High Flow, Harbor) ID = 0.277" with 1/4" NPT male thread
- 3/8" Male hole = 0.283" - 0.285" with thread of 3/8" - NPT (ID of female mating OD appears even smaller ID).
- 1/2" Male hole = 0.375" (0.655" OD)

Hose Notes: Actual Internal Diameters on brass fittings (i.e. swedged on ends) of standard Goodyear, etc. brands of 1/2" & 3/8" hose have internal dimensions different from their description. (Example = Goodyear 1/2" Red hose with 3/8" / 9.5mm NPT fitting has internal diameter hole of 0.282", which is sufficient for 602 and 625 units but undersized for 625X, 650, and 660 units.

Note: Goodyear black 3/8" / 9.5mm hose has Internal Diameter hole on swedged fittings of ~0.265" suitable for 602 and 625 units only.

Compressor Tip: Each additional hp (kW) of motor capacity will generate about 4 CFM (1.9 L/s) of compressed air at 90 psi (6.2 bar) on a typical compressor > over 10 hp.

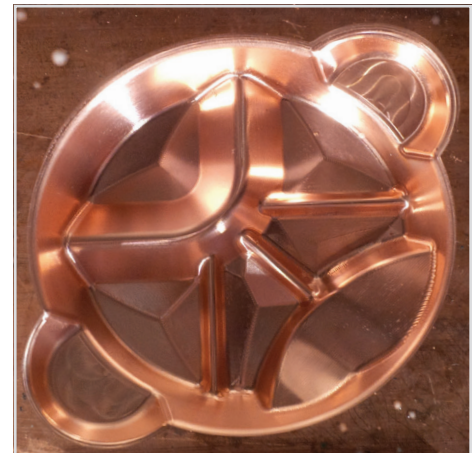
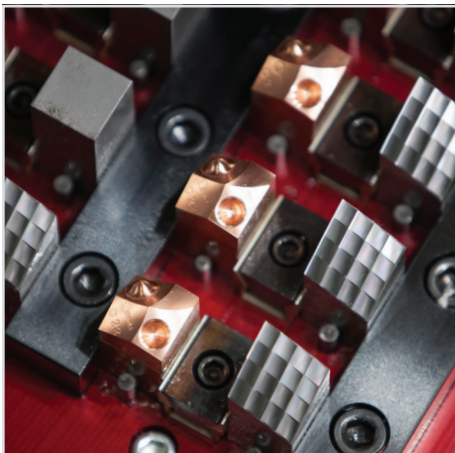

Please see full installation notes, user notes and videos at www.airturbine tools.com

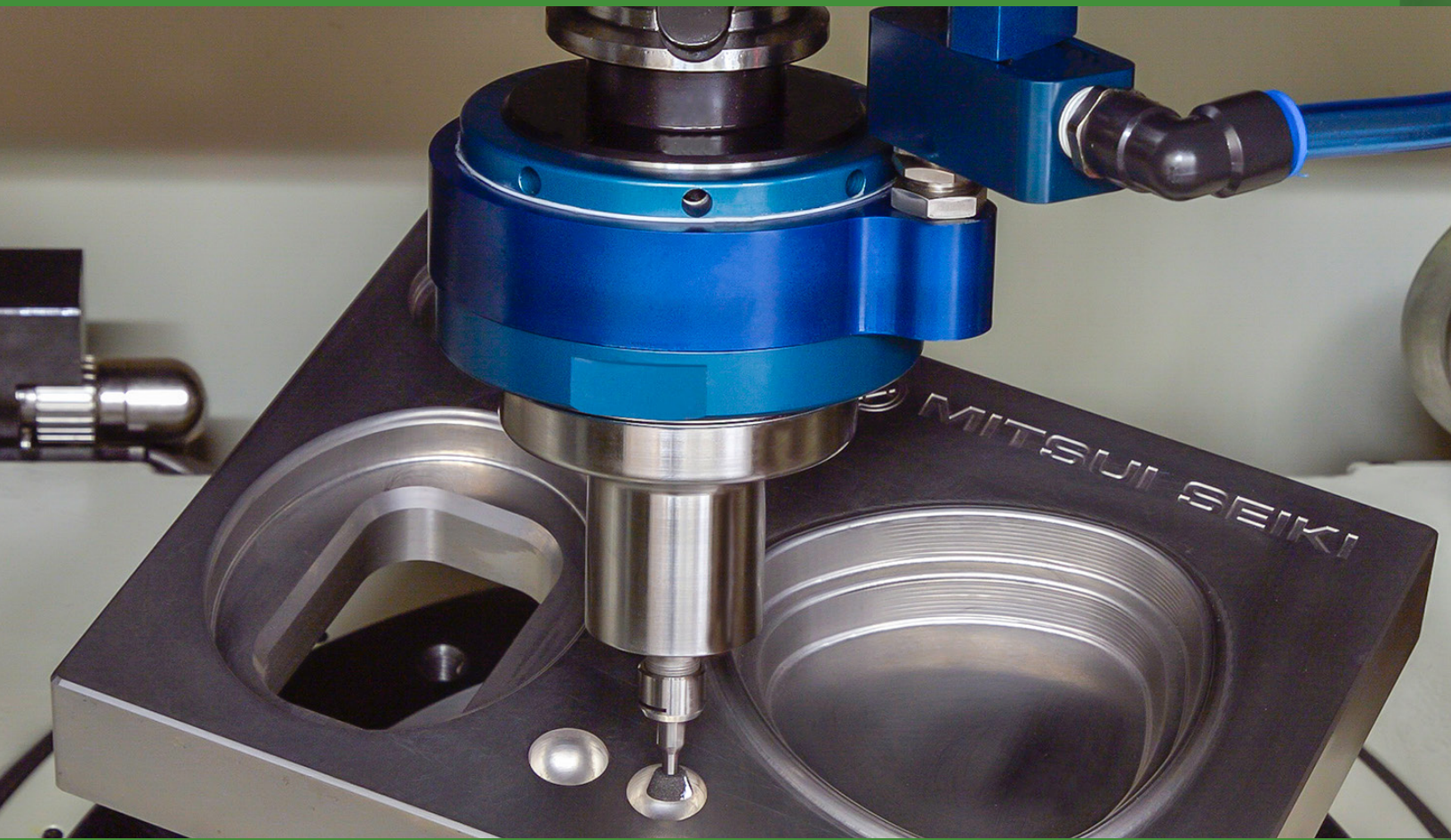

Hand Tools Series

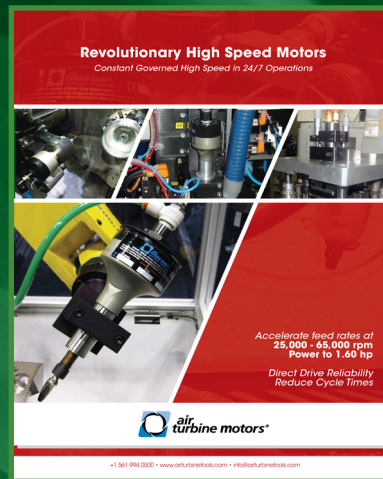

Motor Mounts Series



1225 Broken Sound Parkway, NW, Suite. D • Boca Raton, Florida 33487, USA

Phone: +1.561.994.0500 • Fax: +1.561.994.8097 • info@airturbinetools.com • www.airturbinetools.com

Do not use couplings / hoses less than 1/4" / 6mm Internal Diameter (ID). Use couplings / hoses with a minimum ID of 6.5mm for 602 and 625 spindles, a minimum ID of 8mm for 625X, 650, 660 spindles and (602, 625, 625X, 650 and 660 spindles with TMA) and a minimum ID of 10mm for 650X spindles and (650X spindles with TMA). Always use a 0.3 micron filter and/or extractor where required and check specified psi or l/s air flow. Use 90 psi / 6.2 Bar clean, dry, oil-free air only. Use eye protection and follow safety instructions. Supply is subject to Air Turbine Tools Inc, terms and conditions of sale and distributor policies in effect for the time being. Subject to availability, change of specifications, price and terms without notice. All specifications approximate.

Air Turbine Spindles® is the registered trade name of Air Turbine Tools, Inc. © 2021 Air Turbine Tools, Inc. All rights reserved.