

ETHOS 60's Dual Harmonic Bias Trem

www.customtonesinc.com

Overview:

Custom Tones is thrilled to unveil the ETHOS 60's Dual Harmonic Bias Trem (60's DHBT). Building on the foundation of our original single unit Harmonic Bias Trem, this Dual version elevates your sound experience with complete STEREO capability, plus the versatility of series CASCADE configuration. The STEREO setup allows for captivating three-dimensional harmonic richness, while the CASCADE feature invites complex rhythmic modulations that are an absolute joy to play.

We're delighted to introduce a range of Custom Shop options, giving artists the freedom to customize the DHBT to their preferences. Whether it's repurposing ACTIVE Footswitch functionality or selecting a Stereo-Stacking configuration mode with just a flick of a switch, you'll have the tools to create your ideal sound.

Specifications:

I/O

- Input Power: 9VDC (regulated), 200mA, Center Negative, 2.1mm x 5.5mm (Note: voltages greater than 9VDC can damage the unit)
- Input: Instrument Input, ¼" jack, $Z_{in} = 1$ Megohm (Active mode)
- Output: Effect Output, ¼" jack, $Z_{out} = 10Kohm$ (Active mode)

FOOT SWITCHES

- ACTIVE: Selects Between Effect vs True Bypass
- SPEED: Selects Between Slow and Fast Modulation
- MODE: Selects Between Amplitude vs Harmonic Modulation Mode

CONTROLS

- SLOW SPEED: Controls Slow Tremolo Speed
- FAST SPEED: Controls Fast Tremolo Speed
- INTENSITY: Controls Depth of Tremolo
- VTRIM: Controls Volume of Tremolo
- TONE: Controls the Top End of the Tremolo
- LFO PHASE: Configures the LFO's between Channel A and B to be in or out-of-phase when LFO's are synchronized.
- LFO SYNC: Enables Channel A's SLOW, FAST and INTENSITY knobs to act as Master controls for both channel A and B.

DIMENSIONS

HxWxD 2.5" x 4.75" x 7.25"



ETHOS 60's Dual Harmonic Bias Trem

www.customtonesinc.com

BASE MODEL



Channel B
VERSION 1

Channel A
VERSION 1

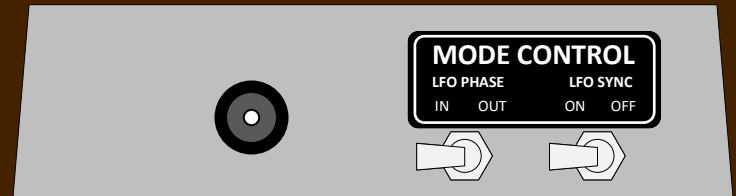

LFO PHASE:
Configure the LFO's between Channel A and B to be in or out-of-phase when LFO's are synchronized.

LFO SYNC:
Enables Channel A's SLOW, FAST and INTENSITY knobs to act as Master controls for both channel A and B.

STEREO OUT



STEREO IN

STEREO CONFIGURATION

MONO OUT

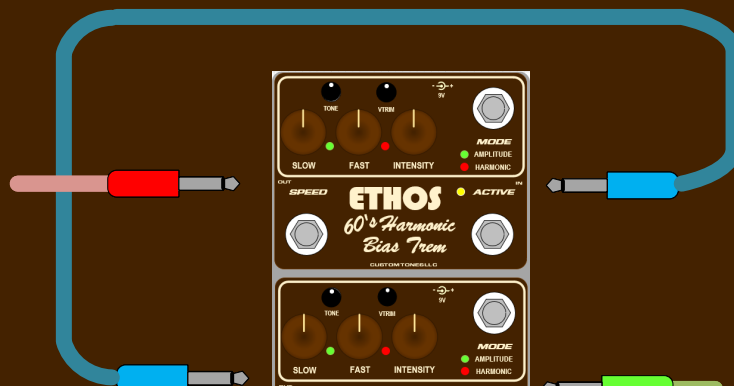

MONO IN

MONO STACKED CONFIGURATION

"Custom Shop Options"

OPTION 1.

Channel A VI/V2 Voice Select



OPTION 2.

Channel B VI/V2 Voice Select



OPTION 3.

Channel A and B VI/V2 Voice Select



VI/V2 Voice Select: The original VI Harmonic Trem produces a bass-heavy harmonic voice, delivering a deep tone. Some musicians find this low-end emphasis a bit excessive, especially with bass-heavy amplifiers, or feel it contrasts too much with their bypass tone. To address this we are offering a **2-Mode Voice Switch**. The VI setting preserves the original harmonic voice, whereas the V2 position revoices the pedal to reduce the low end to align more with the bypass tone.

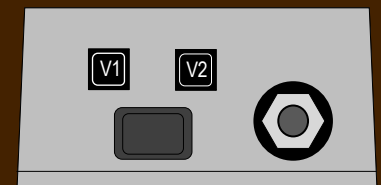

OPTION 4.

INPUT CONFIGURATION SELECTOR

Eliminates the need for external jumper cables

- A-B STACKED = Output of CHANNEL A is connected to Input of CHANNEL B
- A-B SEPARATE = CHANNELS A and B inputs are independent
- A-B BRIDGED = CHANNELS A and B are bridged



"Custom Shop Options"

OPTION 5. MASTER ACTIVE FOOT SWITCH

Channel A's footswitch acts as the MASTER activation footswitch for both channels A and B. Channel B's active footswitch is operational only when the Channel A active footswitch is ON [active]



OPTION 6. ACTIVE FOOT SWITCH ASSIGNMENT

Used with the MASTER Active FS Option, This switch selects between Channel A and Channel B's Active FS's being independent or Channel A's FS being the MASTER FS as described above.

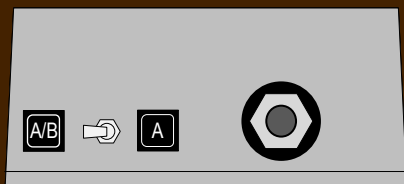

OPTION 7. TREM KILL FOOTSWITCH INTERFACE

Artists are using the harmonic mode preamp voice of the Trem without modulation as it offers a distinctive tone reminiscent of SRV or Big Dipper sounds. The Trem Kill Interface enables the pedal to function as a preamp while allowing users to toggle the tremolo modulation ON or OFF instantly via a remote footswitch. This interface features a 1/4" female phone jack on the unit's side. Trem modulation is disabled when the tip is shorted to the ring (ground) of the jack. [Only available on CHANNEL A]



"STEREO TO STEREO" CONFIGURATON

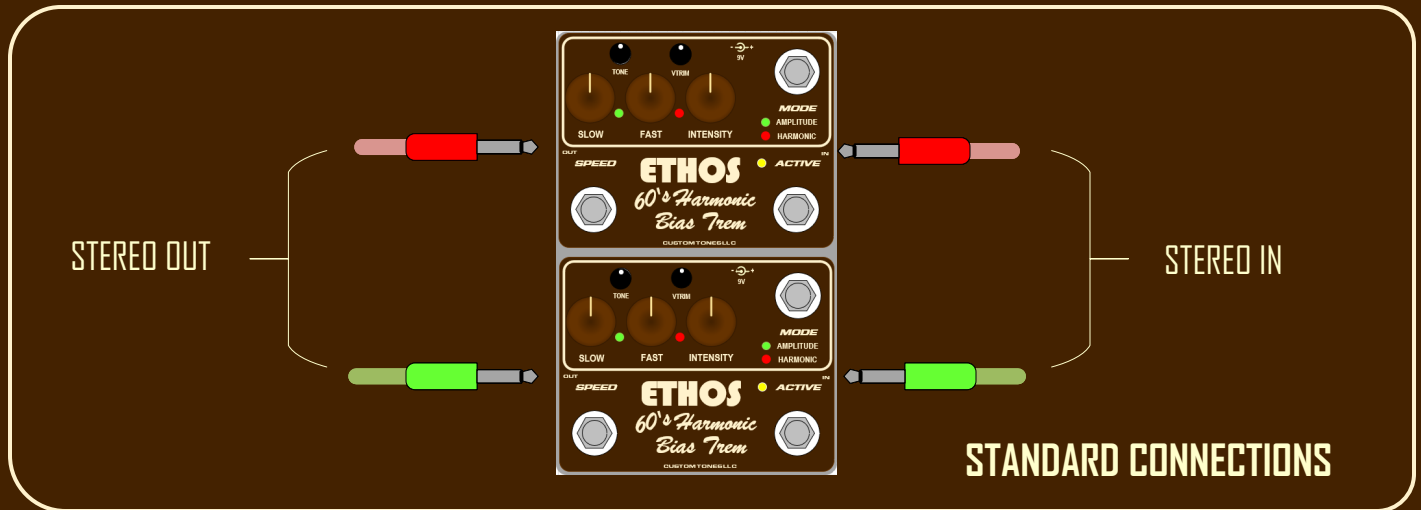

OR

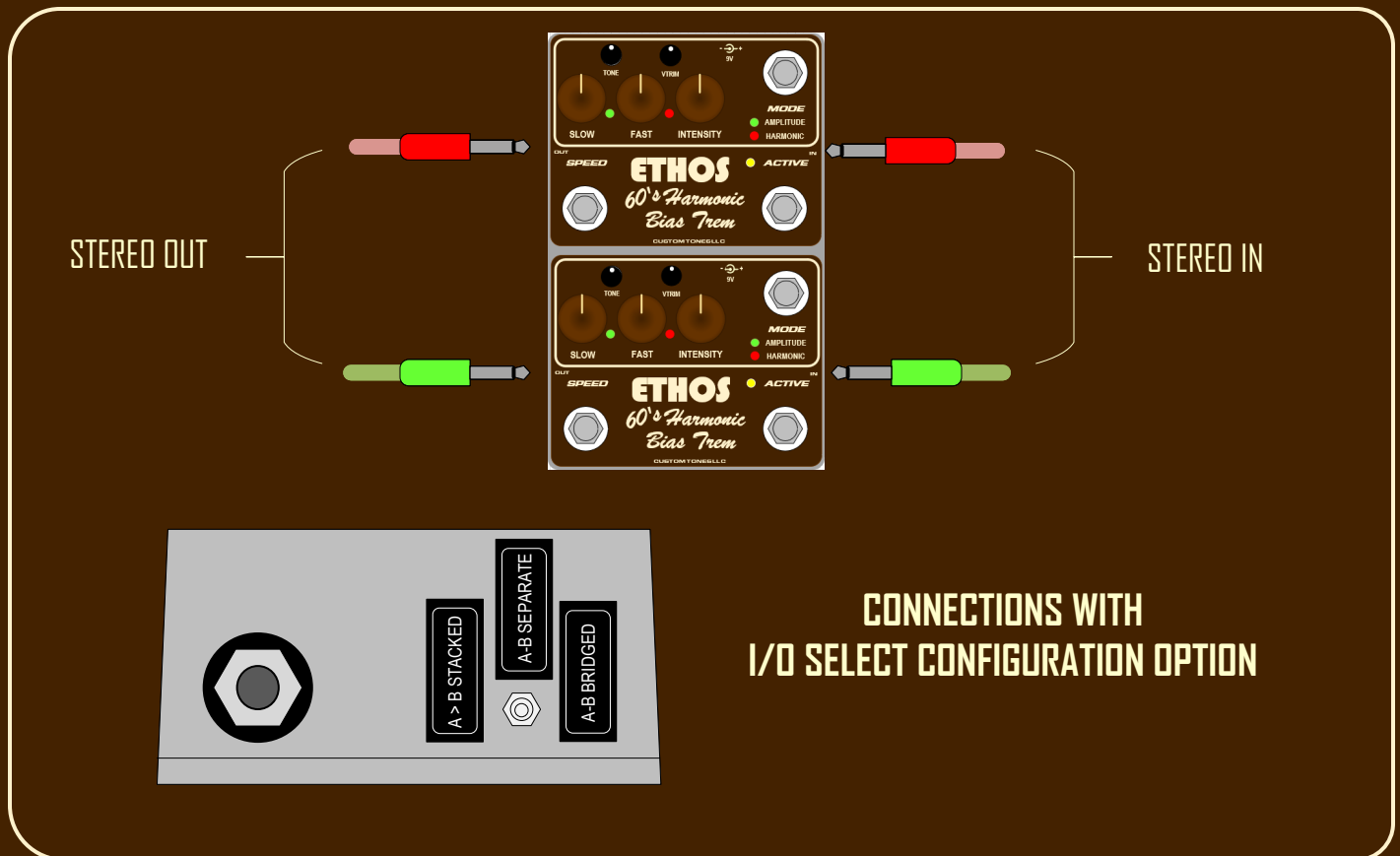

"MONO TO STEREO" Configuration set-ups

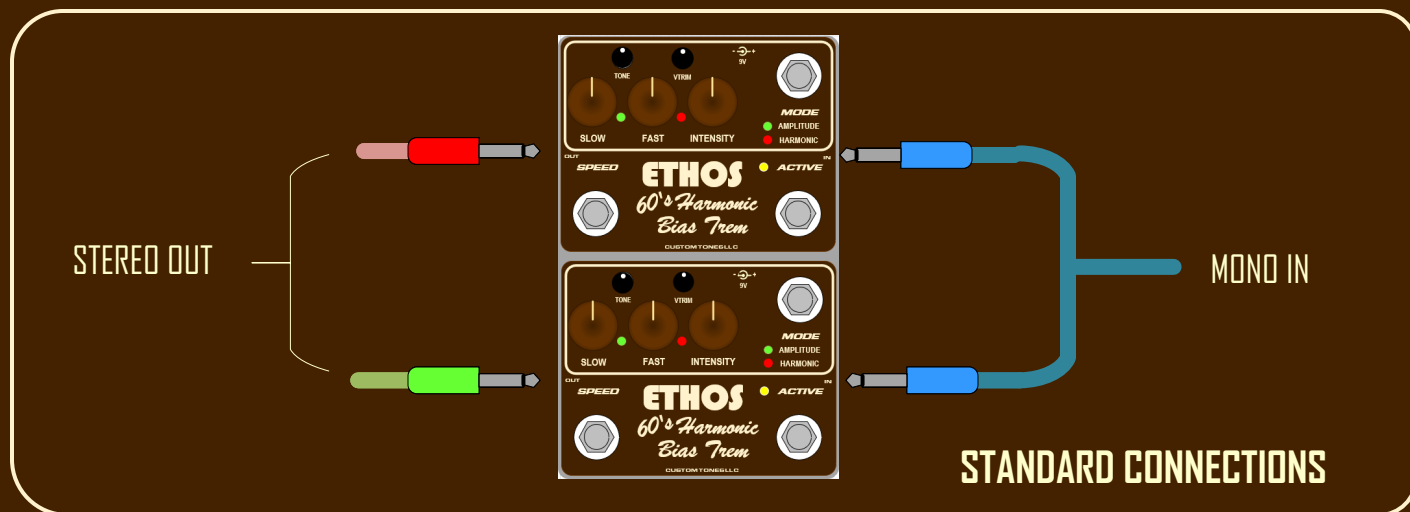

OR

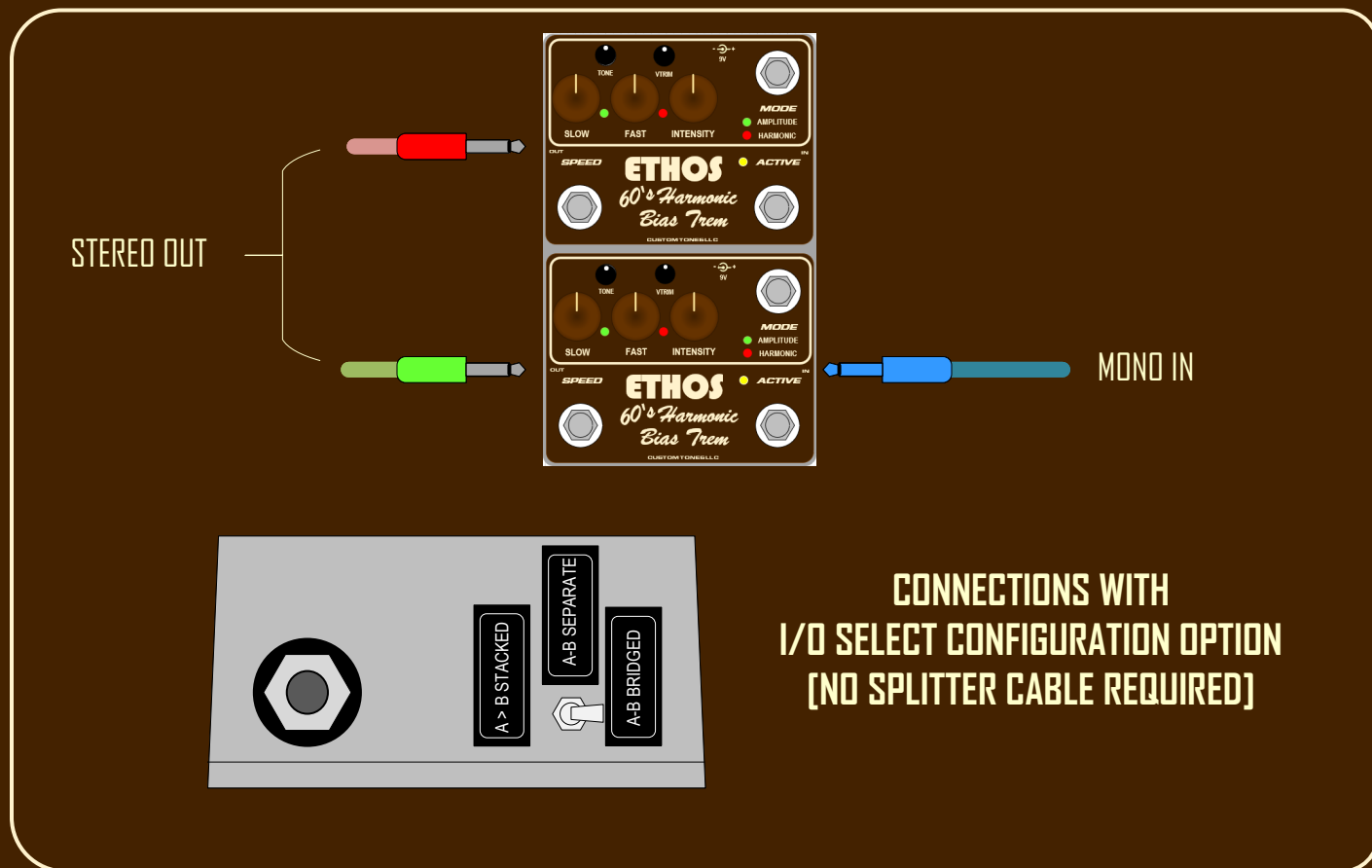

"MONO STACKED CHA -> CHB" Configuration set-ups

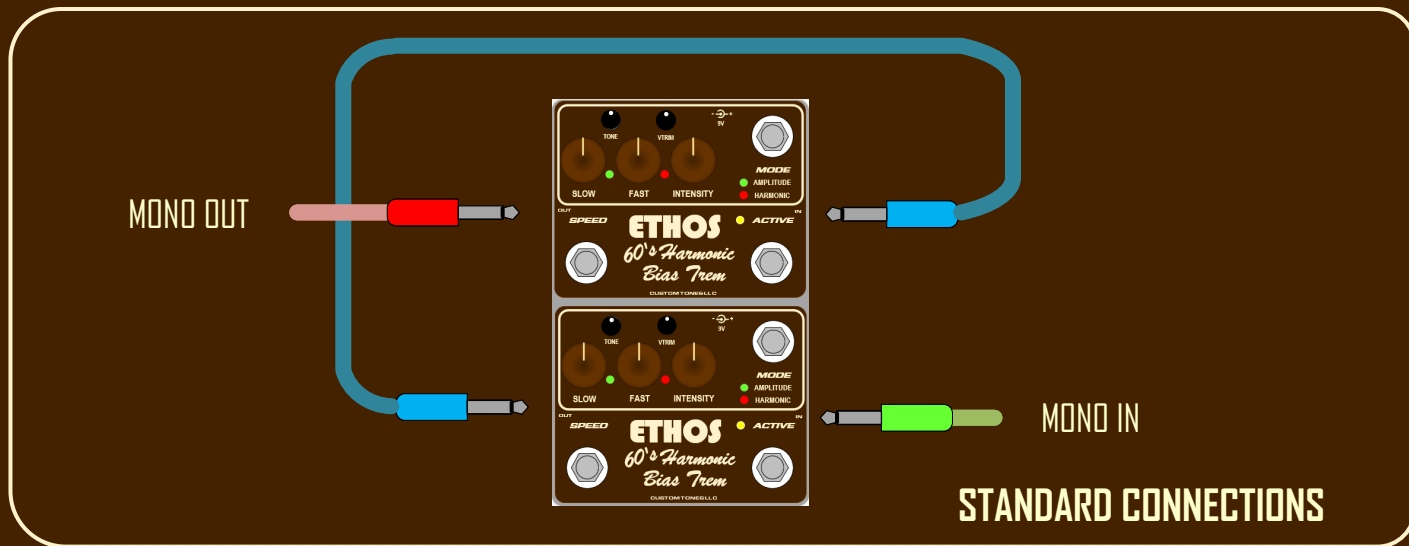

OR

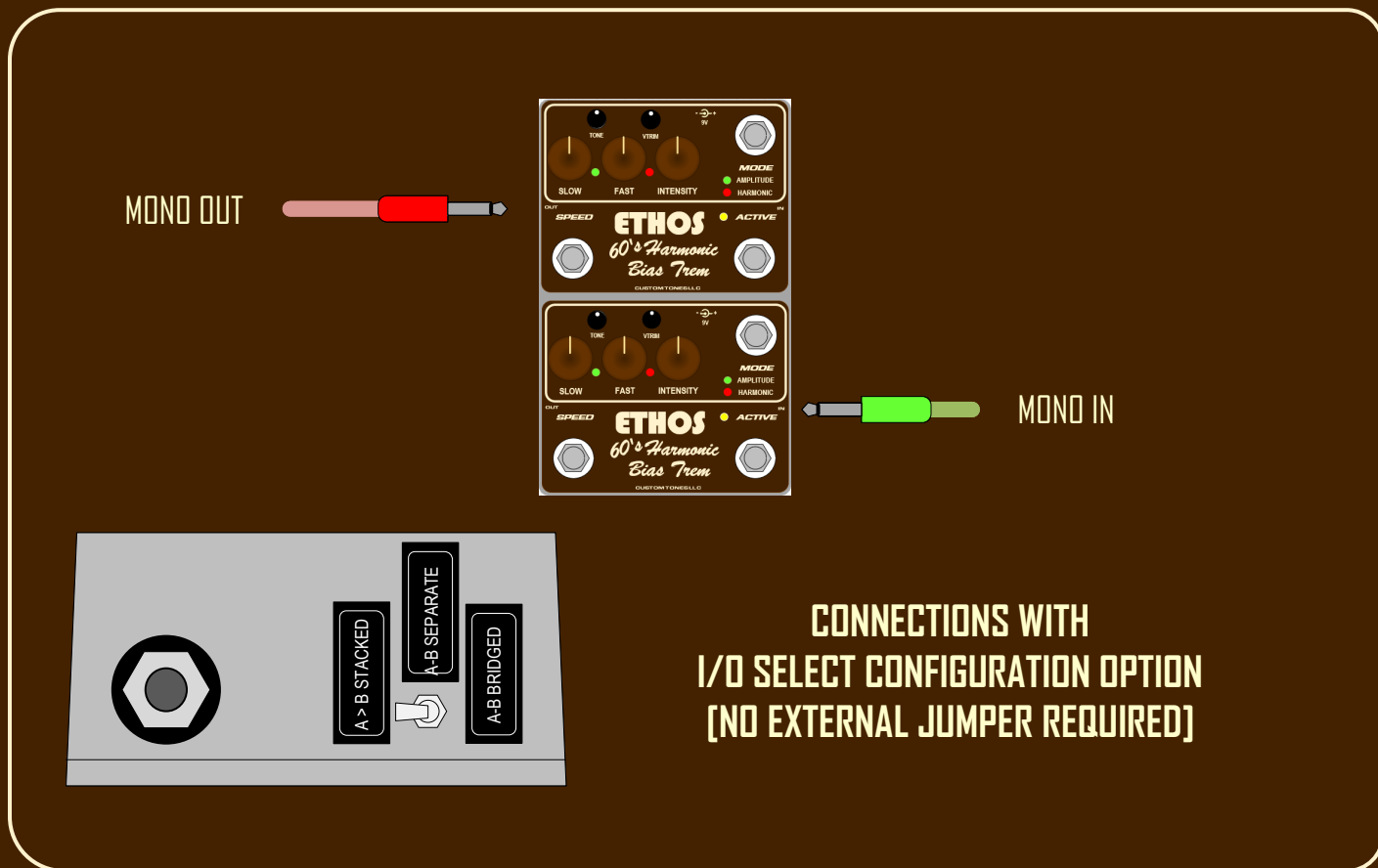

FUN SETTINGS

STEREO
OUT

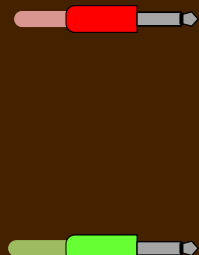

Whirlwind

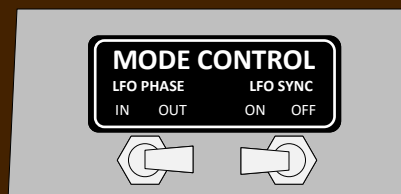

Input set up: STEREO TO STEREO, OR MONO TO STEREO

STEREO
OUT

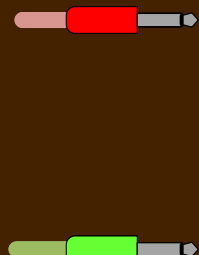

Chorusy [Wet-Dry]

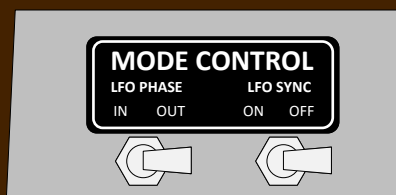

Intensity set to min

Input set up: STEREO TO STEREO, OR MONO TO STEREO

STEREO
OUT

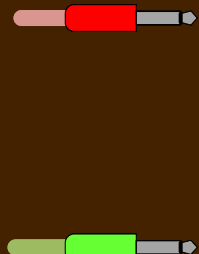

Stereo Complexity



Input set up: STEREO TO STEREO, OR MONO TO STEREO

FUN SETTINGS

MONO
OUT



Double Intensity

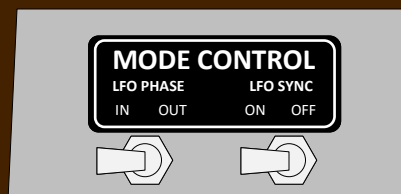

Input set up: "MONO STACKED CHA -> CHB"

MONO
OUT



LFO Beating

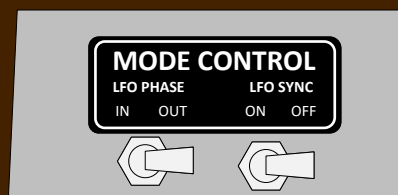

Input set up: "MONO STACKED CHA -> CHB"

MONO
OUT



Freq X2

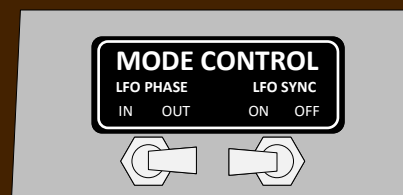

Input set up: "MONO STACKED CHA -> CHB"

"TONE TIPS"

SPEED CONTROL

The speed controls cover 2 different speed ranges where the FAST SPEED range is roughly 2X the SLOW SPEED range. This offers an easy way of dialing in speed. For example when the slow and fast speed controls are set in the same position, e.g. 12:00, the fast speed will be 2X the slow speed.

VOLUME TUNING

Many times turning on a typical tremolo unit will change the guitar's apparent volume. This is due to the effect of the peaks and valley's of the modulation on the base signal when the INTENSITY is turned up. To address this the 60's HBT has a VOLUME TRIM, VTRIM for short, that offers a post modulation gain trim. Once you have set the INTENSITY of the 60'S HBT to your liking, you can adjust the VRTIM to the desired level comparing it to your bypass level.

tone tuning

Tremolo can sometimes effect the tone of your guitar especially when used in the HARMONIC mode where dynamic filtering is taking place. The TONE control provides a degree of post tremolo high frequency adjustment. This can also be very important when using overdrive or distortion pedals to balance out the tremolo's tone with the added harmonic content of those devices.

POWER-UP

At power up internal bias voltages ramp up and stabilize after approximately 45 seconds. During this time switching the unit ON/OFF will generate subtle popping noise and the tremolo intensity will be low. Once the bias voltages fully charge the switching popping will cease and the tremolo intensity will be at its set level.

"BACK GROUND"

Traditionally, bias tremolo has been implemented in tube designs by modulating or changing the amplitude of the guitar's signal via mixing or dynamically biasing the grid or cathode voltage of a vacuum tube with a low frequency oscillator (LFO) signal. The bias voltage shifts the incoming guitar signal into the non-linear region of the tube's transfer function (cut-off) where no current flows. This causes the amplitude of the guitar signal to decrease since the tube's gain incrementally decreases in its non-linear region. This approach equates to a crude voltage-controlled amplifier (VCA). The shape of the modulation is determined by the shape of the LFO bias signal, whether it be a sinewave, triangle wave, square wave or other.

This bias method can be applied to various circuit topologies like a class AB push-pull amplifier, or a class A preamp. In the case of the Fender five triode harmonic tremolo, two out-of-phase LFO bias voltages are mixed with the guitar signal at the grids of two class A triodes where one tube input is configured as a low pass filter and the other a high pass filter. The outputs of the tubes are mixed summing the signals. This results in a modulated signal that is not only amplitude dynamic, but frequency response dynamic as well.

Typical harmonic tremolo pedals utilize either LDRs, JFETs, Transconductance Amplifiers or S/W based DSPs to perform the VCA function. The 60's Harmonic Bias Trem doesn't use any of those VCA methods but instead uses an analog solid-state circuit that mimics the characteristics of a triode that is dynamically biased in the same manner described above to obtain the modulation behavior.

The 60's Harmonic Bias Trem offers both amplitude and harmonic tremolo. In the amplitude mode, only the amplitude of the signal is modulated, whereas in the harmonic mode, the frequency response of the signal is affected. Both of these modulations are created using the bias technique. You can select between these modulations using the MODE footswitch.

The speed of the tremolo can be selected using the SLOW and FAST SPEED controls. The controls cover two speed ranges where you can select between the two speeds using the SPEED SELECT foot switch. Two ranges are used so you have better control resolution when selecting a SPEED.

The depth of the modulations is controlled by the INTENSITY control. You can balance the tone and volume of the tremolo effect against your bypass signal by using the VTRIM and Tone Controls. The bypass mode is "true bypass" where there are no active buffers or circuits in line with the guitar signal.