

**COMANCHE 260**



**OWNER'S HANDBOOK**

753-685

*the*



## Owner's Handbook

PIPER

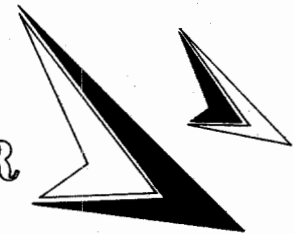

**Piper Aircraft Corporation, Lock Haven, Pa.  
U. S. A.**

**INDEX (cont.)**

	Page
Care of Air Filter . . . . .	55
Care of Windshield and Windows . . . . .	55
Serial Number Plate . . . . .	56
Fuel System . . . . .	56

Additional copies of this manual may be purchased by writing to the SERVICE SPARES DIVISION, PIPER AIRCRAFT CORPORATION, Lock Haven, Pennsylvania, 17745, U.S.A.

Published By  
PUBLICATIONS DEPARTMENT  
Piper Aircraft Corporation  
753 685  
Issued: September 1964  
Revised: January 1965  
Revised: February 1966

# THE PIPER COMANCHE

## INDEX (cont.)

	Page
Climb . . . . .	29
Cruising . . . . .	29
Approach and Landing . . . . .	30
Stopping Engine . . . . .	31
Emergency Procedure . . . . .	32
Mooring . . . . .	34
Operating Tips . . . . .	34
Radio Operation . . . . .	36
SECTION IV	
Performance Charts . . . . .	37
Take-off Distance over 50 Foot Barrier . . . . .	37
Take-off Ground Run Distance . . . . .	38
Speed For Best Rate and Angle of Climb . . . . .	39
Climb Rate vs Standard Altitude and Weight . . . . .	40
True Airspeed vs Altitude . . . . .	41
Range vs Standard Altitude . . . . .	42
Landing Distance over 50 Foot Barrier. . . . .	43
Landing Ground Roll. . . . .	44
Altitude Conversion Chart . . . . .	45
Power Setting Table, Lycoming O-540-E . . . . .	46
Power Setting Table, Lycoming IO-540-D. . . . .	47
Part Throttle Fuel Consumption, IO-540-D . . . . .	48
Fuel Flow Indicator, Lycoming IO-540-D. . . . .	49
SECTION V	
Maintenance . . . . .	50
Tire Inflation . . . . .	50
Battery Service. . . . .	50
Brake Service . . . . .	51
Landing Gear Service . . . . .	51
Fuel and Oil Requirements . . . . .	53
Leveling and Rigging . . . . .	54

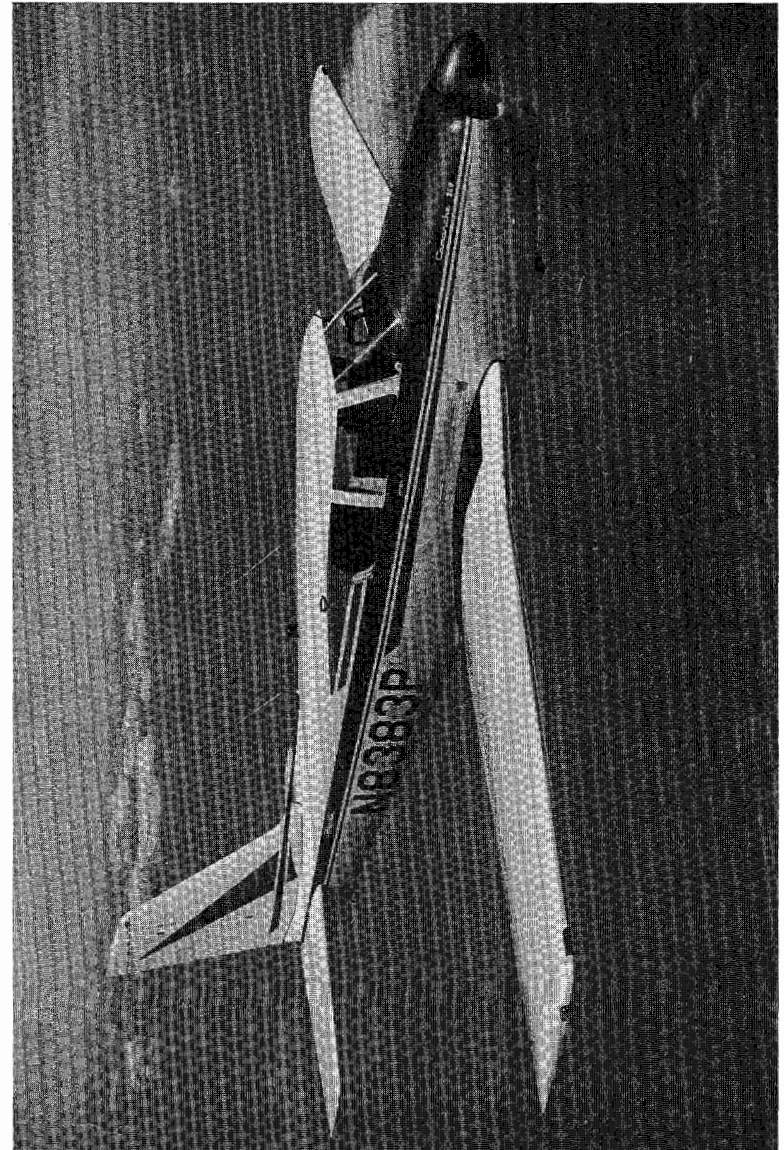

**INDEX**

	Page
<b>SECTION I</b>	
Specifications . . . . .	1
Power Plant . . . . .	1
Performance . . . . .	1
Weights . . . . .	2
Fuel . . . . .	2
Baggage . . . . .	2
Dimensions . . . . .	3
Landing Gear . . . . .	3
<b>SECTION II</b>	
Design Information . . . . .	5
Engine and Propeller . . . . .	5
Induction System . . . . .	6
Structures . . . . .	7
Landing Gear . . . . .	8
Control System . . . . .	10
Fuel System . . . . .	10
Electrical System . . . . .	13
Heating and Ventilating System . . . . .	15
Instrument Panel . . . . .	16
Vacuum System . . . . .	17
Baggage Compartment . . . . .	18
Seats . . . . .	18
Finish . . . . .	18
<b>SECTION III</b>	
Operating Instructions . . . . .	20
Preflight . . . . .	20
Starting Engine (Carburetor) . . . . .	21
Starting Engine (Fuel Injection) . . . . .	22
Warm-up and Ground Check . . . . .	23
Take-off . . . . .	27
Stalls . . . . .	28

## SECTION I SPECIFICATIONS

Power Plant . . . . .	1
Performance . . . . .	1
Weights . . . . .	2
Fuel . . . . .	2
Baggage . . . . .	2
Dimensions . . . . .	3
Landing Gear . . . . .	3

**NOTES**



**SERIAL NUMBER PLATE**

The serial number plate is located outside of fuselage to the left of the tail skid. The serial number of the plane should always be used in referring to the airplane in service or warranty matters.

**FUEL SYSTEM**

The fuel screens in the strainer, the carburetor injector screen and fuel nozzles will require cleaning at the first 25 hour inspection and every 50 hour inspection thereafter. The screen in the carburetor and injector is located in the housing where the fuel inlet line connects to the injector. The fuel strainer located under the floorboards are accessible for cleaning through an access plate on the bottom of the fuselage. When reassembling the strainer after cleaning, a small amount of grease applied to the gasket will facilitate assembly. Acetone is recommended for cleaning these screens.

**SPECIFICATIONS:****POWER PLANT****PA-24-260**

Engine (Lycoming)	*O-540-E or **IO-540-D
Rated Horsepower	260
Rated Speed (rpm)	2700
Bore (inches)	5.125
Stroke (inches)	4.375
Displacement (cubic inches)	541.5
Compression Ratio	8.5:1
Dry Weight (pounds)	*397/**402

**PERFORMANCE**

Take-off Ground Run (ft.)	1090
Take-off Ground Run (ft.) (short field)	660
Take-off Run over 50 ft. barrier	1540
Best Rate of Climb Speed (MPH)	110
Best Rate of Climb (ft. per min.)	1500
Best Angle of Climb Speed (MPH)	85
Service Ceiling (ft.)	20,600
Absolute Ceiling (ft.)	22,000
Top Speed (MPH)	195
Cruising Speed (75% power at sea level) (MPH)	173
Optimum Cruising Speed (75% power at 7000 ft.) (MPH)	185
Optimum Cruising Speed (65% power at 10800 ft.) (MPH)	178
Stalling Speed (flaps extended) (MPH)	61
Stalling Speed (flaps retracted) (MPH)	70
Landing Ground Roll (ft.)	920
Landing Ground Roll (short field) (ft.)	650
Landing Distance over 50 Ft. barrier (ft.)	1420
Fuel Consumption (2400 RPM 75% power) (gph)	14.1
Fuel Consumption (2400 RPM 65% power) (gph)	12.7

**SPECIFICATIONS: (cont.)****PERFORMANCE**

Cruising Range (75% power at 7000 ft.) ( mi.)	1120#
Cruising Range (65% power at 10, 800 ft.) (mi.)	1205#
Cruising Range (55% power at 15, 400 ft.) (mi.)	1265#
# 86 gal. available fuel	

Published figures are for Standard airplanes flown at gross weight under standard conditions at sea level unless otherwise stated.

**WEIGHTS**

Gross Weight (lbs.)	2900
Empty Weight (Standard) (lbs.)	1700
USEFUL LOAD (Standard) (lbs.)	1200
Empty Weight (Professional 422) (lbs.)	1793
USEFUL LOAD (Professional 422) (lbs.)	1107

**FUEL**

Fuel Capacity (gal.) (Standard)	60
Fuel Capacity (gal.) (With Reserve)	90
Unuseable Fuel (Inboard tanks only)	4
Fuel Aviation Grade (Min. Octane)	91/96
Oil Capacity (qts.)	12

**BAGGAGE**

Maximum Baggage (lbs.)	200
Baggage Space (cubic ft.)	20
Baggage Door Size (in.)	20 x 20

**CARE OF AIR FILTER**

The induction air filter must be cleaned at least once every fifty hours and depending on the type of condition existing, it may be necessary to clean the filters daily or every five hours. Extra filters are inexpensive and should be kept on hand and used for rapid replacement.

The following cleaning procedure is recommended by the manufacturer of the filter:

- (1) Remove air scoop.
- (2) Remove filter from cowling.
- (3) Tap gently to remove dirt particles. Do not use compressed air.
- (4) Reassemble to cowling and replace scoop.

**CARE OF WINDSHIELD AND WINDOWS**

A certain amount of care is required to keep the plexiglas windows clean and clear. The following procedure is recommended:

- (1) Flush with clean water and dislodge excess dirt, mud, etc., with your hand.
- (2) Wash with mild soap and warm water. Use a soft cloth or sponge. (Do not rub.)
- (3) Remove oil, grease or sealing compounds with a cloth soaked in kerosene.
- (4) After cleaning, apply a thin coat of hard polishing wax. Rub lightly with a soft dry cloth.
- (5) A severe scratch or mar can be removed by using jeweler's rouge to rub out scratch, smooth on both sides and apply wax.

**LEVELING AND RIGGING**

Leveling the Comanche for purposes of reweighing or rigging is accomplished as follows:

(1) Partially withdraw two machine screws located on the side of the fuselage over the baggage door. These screws are leveling points and the airplane is longitudinally level when a level placed on the head of these screws indicates level.

(2) To put the airplane in a longitudinally level position on scales, first block the main gear oleos to full extension, then deflate the nose wheel tire until the proper position is reached. For rigging purposes, place airplane on jacks.

(3) To level the airplane laterally, place a level across the floorboard at station 136.5 bulkhead (in baggage compartment between rear spar attachment points).

**Rigging:** Although the fixed flight surfaces on the Comanche obviously cannot be adjusted in position for rigging purposes, it may be necessary on occasion to check the position of these surfaces. The movable surfaces, with the exception of the flaps, all have adjustable stops as well as adjustments on their cables or push-pull connections so that their range of movement can be altered. The positions and travels of the various surfaces are as follows:

- (1) Wings:  $5^{\circ}$  dihedral, no twist.
- (2) Stabilator: No dihedral, travel  $-14^{\circ} \pm 1^{\circ}$  up,  $4^{\circ} \pm 1^{\circ}$  down.
- (3) Fin: Should be vertical and in line with center of fuselage.
- (4) Ailerons: Travel  $19^{\circ} \pm 2^{\circ}$  up,  $15^{\circ} \pm 2^{\circ}$  down.
- (5) Flaps: Travel  $-32^{\circ} \pm 1^{\circ}$  full down.
- (6) Rudder: Travel  $25^{\circ}$  left or right,  $\pm 2^{\circ}$ .
- (7) Horizontal Tail Tab Travel:  $7^{\circ} \pm 1^{\circ}$  up,  $15^{\circ} \pm 1^{\circ}$  down.
- (8) Stabilator Tab Ratio: 1 1/2 : 1

For purposes of changing the lateral trim, a fixed tab is provided on the left aileron which can be adjusted as necessary.

**SPECIFICATIONS: (cont.)****DIMENSIONS**

Wing Span (ft.)	35.98
Wing Area (sq. ft.)	178
Length (ft.)	24.99
Height (ft.)	7.47
Wing Loading (lbs. per sq. ft.)	16.3
Power Loading (lbs. per HP)	11.15
Propeller Diameter (in.)	77

**LANDING GEAR**

Wheel Base (ft.)	6.55
Wheel Tread (ft.)	9.66
Tire Pressure (psi)	Nose 27
	Main 42
Tire Size	Nose (four ply rating) 600 x 6
	Main (six ply rating) 600 x 6

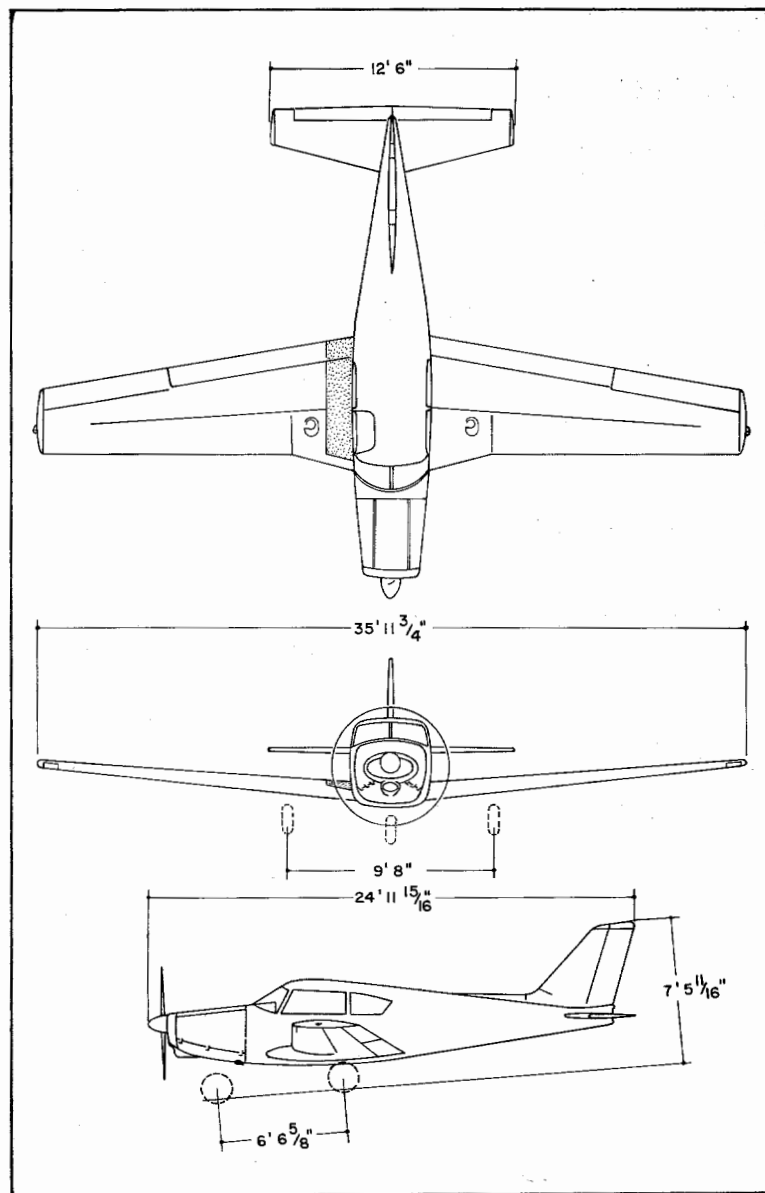

according to instructions on the units. All three oleos should be extended until about 2-3/4 inches of oleo piston tube is exposed under static load.

To add air to the oleo struts, a strut pump is attached at the air valve and the oleo pumped up to the proper position. To add oil, jack the aircraft, release the air through the strut valve and allow the strut to extend fully. Next remove the air valve and fill the unit through this opening. Then compress the oleo to within 1/4 inch of full compression, allowing air and excess oil to escape. Then reinsert the valve core and pump up the strut.

## FUEL AND OIL REQUIREMENTS

Aviation Grade 91/96 Octane (minimum) fuel must be used in the Comanche. The use of lower grades of fuel can cause serious engine damage in a very short period of time and is considered of such importance that the engine warranty is invalidated by such use.

The oil capacity of the Lycoming O-540-E or IO-540-D is 12 quarts and the minimum safe quantity 2-3/4 qts. The operating oil level is normally kept a quart or more below the maximum to reduce oil consumption. It is recommended that engine oil be changed every 50 hours or sooner under unfavorable conditions. The following grades are required for the specified temperatures:

Temperatures above 60° F	S. A. E. 50
Temperatures between 30° F and 90° F	S. A. E. 40
Temperatures between 0° F and 70° F	S. A. E. 30
Temperatures below 10° F	S. A. E. 20

level, but must not be filled above the baffle plates. All connections must be clean and tight.

If the battery is not up to proper charge, recharge starting with a charging rate of 4 amps and finishing with 2 amps. Quick charges are not recommended.

## BRAKE SERVICE

The brake system is filled with MIL-H-5606 (petroleum base) hydraulic brake fluid. This should be checked at every 50 hour inspection and replenished when necessary, refilling the brake reservoir on the firewall to the indicated level.

No adjustment of brake clearances is necessary on the Comanche brakes. If after extended service the brake blocks become worn excessively, they are easily replaced with new brake segments.

Main wheels are easily removed by taking off the axle nut and withdrawing the wheel from the axle. To remove the brake disc and lining, remove the three bolts through the brake housing.

Tires are dismounted from the wheels by deflating the tube, then removing the wheel through-bolts, allowing the wheel halves to be separated.

## LANDING GEAR SERVICE

In jacking up the Comanche for landing gear and other service, a jack kit (available through the Piper Aircraft Distributor Service Departments) should be used. This kit includes two hydraulic jacks and a tail support. Approximately 300 lbs. of ballast should be placed on the base of the tail support before jacking up the airplane.

Landing gear oleos on the Comanche should be serviced

## SECTION II

### DESIGN INFORMATION

## ENGINE AND PROPELLER

The Comanche 260 is powered by a Lycoming O-540-E, carburetor induction engine or a Lycoming IO-540-D, fuel injection engine. Both engines are rated at 260 HP at 2700 RPM, with a compression ratio of 8.5 to 1 and require 91/96 minimum octane aviation fuel. The six cylinder, direct drive engines are equipped with a geared starter, 12 volt 75 ampere alternator, carburetor or fuel injector, vacuum pump, diaphragm fuel pump and shielded ignition system.

Engine mount is of steel tubing construction and incorporate vibration absorbing dynafocal mounts. The all aluminum engine cowl, is a cantilever structure attached at the firewall. Side panels are hinged for quick access to the engine compartment.

The exhaust system consists of dual exhaust stacks and mufflers with the exhaust gases being directed over-board at the bottom rear of the cowl, on each side of the nose gear. Heat for the cabin interior and defrosting is taken from the left muffler shroud.

An efficient aluminum oil cooler is mounted on the left front engine baffle. Engine oil drainage is accomplished by a quick drain installed in the right side of the engine sump.

The propeller on the Comanche is a Hartzell HC-C2YK-1A/8467-7R constant-

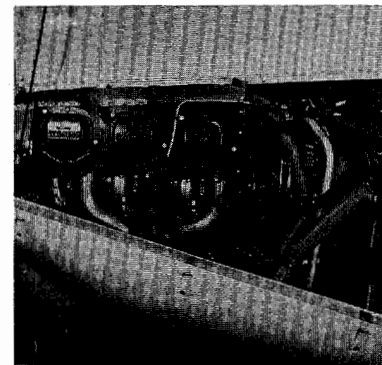

speed, controllable unit. It is controlled entirely by use of the propeller control located in the center of the lower instrument panel.

## INDUCTION SYSTEM

The Lycoming engine induction system in the Comanche is equipped with a Marvel Schebler model MA-4-5 carburetor or a Bendix RSA-5AD1 fuel injector.

The carburetor installed on the O-540-E engine is of the single barrel float type, and is equipped with a manual altitude mixture control and an idle cut-off. Distribution of the fuel-air mixture to each cylinder is obtained by the center zone induction system, which is integral with the oil sump and is submerged in oil, insuring a more uniform vaporization of fuel. From the riser the fuel-air mixture is distributed to each cylinder.

The fuel injector installed on the IO-540-D engine is based on the principle of measuring air flow and using the air flow signals to operate a servo valve. The accurately regulated fuel pressure established by the servo valve, when applied across a fuel control (jetting system), makes fuel flow proportional to air flow.

Fuel pressure regulation, by means of the servo valve; necessitates only a minimum fuel pressure drop through the entire metering system. This makes it possible to maintain metering pressure above vapor forming conditions, and at the same time requires a fuel inlet pressure sufficiently low so that a diaphragm pump can be used. An inherent feature of the servo system is self-purging which eliminates any possibility of vapor lock and associated problems of difficult starting.

The injection system components consists of a Servo Regulator which meters fuel flow in proportion to air flow to the engine, giving proper fuel-air mixture at all engine speeds. A Flow Divider receives the metered fuel and accurately divides fuel flow to each cylinder Fuel Nozzle.

## SECTION V MAINTENANCE

This section of the Comanche Handbook contains information which pertains to minor maintenance of the airplane. Any complex repair or modification should be accomplished by a Piper Certified Service Center or equivalent.

### TIRE INFLATION

For maximum service from the tires on the Comanche, keep tires inflated to the proper pressure of 42 lbs. on the main wheels and 27 lbs. on the nose wheel. Interchange the tires on the wheels if necessary to produce even wear. All wheels and tires are balanced before original installation, and the relationship of tire, tube and wheel should be maintained whenever possible upon reinstallation. Out of balance wheels can cause extreme vibration in the landing gear during take-off. In the installation of new components, it may be necessary to rebalance the wheels with the tires mounted.

### BATTERY SERVICE

Access to the 12-volt 35-ampere hour battery is through the right rear baggage compartment panel. The stainless steel box has a plastic drain tube which is normally closed off with a clamp and which should be opened occasionally to drain off any accumulation of liquid.

The battery should be checked frequently for proper fluid

Installed in the instrument panel is a Fuel Flow Indicator. This instrument is connected to the flow divider and monitors fuel pressure. The instrument converts fuel pressure to an accurate indication of fuel flow in gallons per hour, percentage of cruise power, and proper leaned mixture for take-off at various altitudes.

### NOTE

An increasing or abnormally high fuel flow indication is a possible symptom of restricted injector lines or nozzles.

Induction air for either engine enters an opening in the nose cowl below the propeller and is picked up by a large air duct. The air is directed through a filter and on to the carburetor or servo regulator. For the fuel injection installation, located in the air box at the throat of the servo regulator is a spring loaded door which opens automatically if the filter becomes blocked.

## STRUCTURES

Structures are of sheet aluminum construction, and are designed to ultimate load factors well in excess of normal requirements. All components are completely zinc chromate primed, exterior surfaces are coated with acrylic lacquer.

The main spars of the wings are joined with high strength butt fittings in the center of the fuselage, making in effect a continuous main spar. The spars are attached to the fuselage at the side of the fuselage and in the center of the structure; wings are also attached at the rear spar and at an auxiliary front spar.

Wing airfoil section is a laminar flow type, NACA-64<sub>2</sub>A215, modified, with minimum thickness about 40% aft of the leading edge. This permits the main spar, located at the point of max-

imum thickness, to pass through the cabin under the rear seat, providing unobstructed cabin floor space ahead of the rear seat.

## LANDING GEAR

The nose gear is steerable with the rudder pedals through a 40 degree arc. During retraction of the gear the steering mechanism is disconnected automatically to reduce rudder pedal loads in flight. The nose gear is equipped with a hydraulic shimmy dampener.

Retraction of the landing gear is accomplished through the use of an electric motor and gear train located under the floorboards, actuating push-pull cables to each of the gears. The landing gear motor is activated by a selector switch located on the instrument panel.

To guard against inadvertent movement of the landing gear selector on the ground, a mechanical guard is positioned just below the selector handle. The handle must also be pulled aft before moving it upward. The gear selector is in the shape of a wheel to differentiate it from the electric flap control knob, which has an airfoil shape. As an added safety feature, the warning horn is connected to the gear selector switch. The

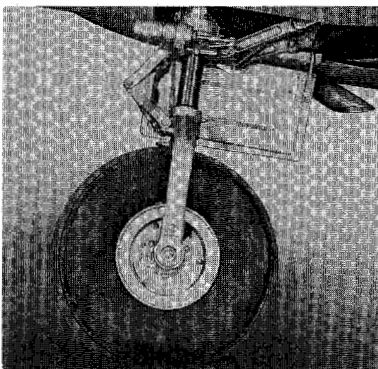

horn will then operate if the selector is moved to the "UP" position with the master switch on and the weight of the airplane is on the landing gear. As a final safety factor to prevent gear retraction on the ground, an anti-retraction switch is installed on the left main gear. This prevents the electric circuit to the landing gear motor from being completed until the gear strut is

## SECTION V

### MAINTENANCE

Tire Inflation . . . . .	50
Battery Service . . . . .	50
Brake Service . . . . .	51
Landing Gear Service . . . . .	51
Fuel and Oil Requirements . . . . .	53
Leveling and Rigging . . . . .	54
Care of Air Filter . . . . .	55
Care of Windshield and Windows . . . . .	55
Serial Number Plate . . . . .	56
Fuel System . . . . .	56



fully extended. A green light on the instrument panel below the landing gear switch is the indication that all gears are down and locked. The warning horn will also sound if the power is reduced below approximately 12" of manifold pressure and the gear has not been lowered.

As optional equipment a visual indicator, located on top of the instrument panel which will pop-up if the gear is retracted and power is reduced below 14" manifold pressure. This indicator is operated mechanically by the landing gear and throttle and therefore has no connection with the electrical system.

The telescoping emergency gear handle should not be used as the primary indication that the gear is down and locked. An amber light above the switch indicates gears up. THE INDICATION LIGHTS ARE AUTOMATICALLY DIMMED WHEN THE NAVIGATION LIGHTS ARE TURNED ON.

The brakes on the Comanche are actuated by toe brake pedals mounted on the left set of rudder pedals and by a hand lever protruding from under the instrument panel. Hydraulic brake cylinders are located above the left rudder pedals and are accessible in the cockpit for servicing. Parking brake valves are incorporated in each cylinder. Two cables extending from the parking brake "T" handle are attached to the parking brake valves. To prevent inadvertent application of the parking brake in flight, a safety lock is incorporated in the valves

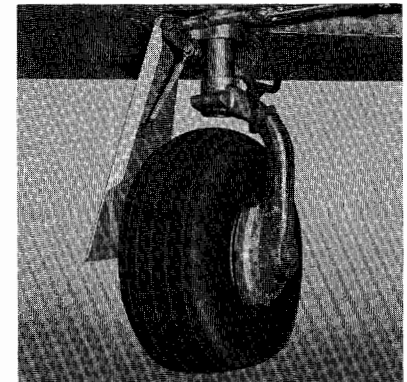
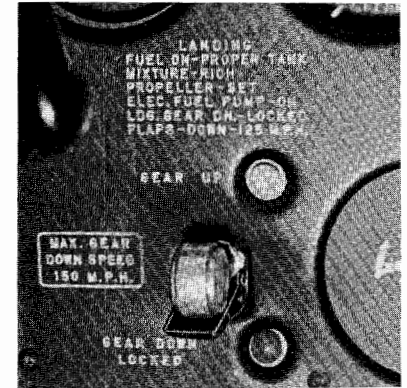

thus eliminating the possibility of pulling out the "T" handle until pressure is applied by use of the toe brakes or the hand lever.

## CONTROL SYSTEM

The flight controls on the Comanche are the conventional three control type operated by a control column and rudder pedals. The all movable stabilator, with an anti-servo tab which also acts as a longitudinal trim tab, provides extra stability and controllability with less size drag and weight.

Provision for directional and longitudinal trim is provided by an adjustable trim mechanism for the rudder and stabilator.

Installed on the Comanche are electrically operated Max-Lift flaps. As the flaps are operated by an electric motor they can be lowered and stopped in any desired position. The flap control switch is located on the nose wheel well just above the rudder trim control. Located on the instrument panel is a flap position indicator which is marked to show the degrees of flap travel. A range for take-off operation is also shown.

Located in the inboard end of the right flap is a lock which holds the flap in the "UP" position so that it can be used as a step for entry or exit. A second lock is incorporated to prevent the flap from going full down in case a step load is applied and the up lock is not fully engaged.

## FUEL SYSTEM

The fuel for the Comanche is carried in two rubber-like fuel cells located in the inboard leading edge sections of the wings. Capacity of these cells, which are classified as the main fuel cells are 30 gallons each (28 gallons useable).

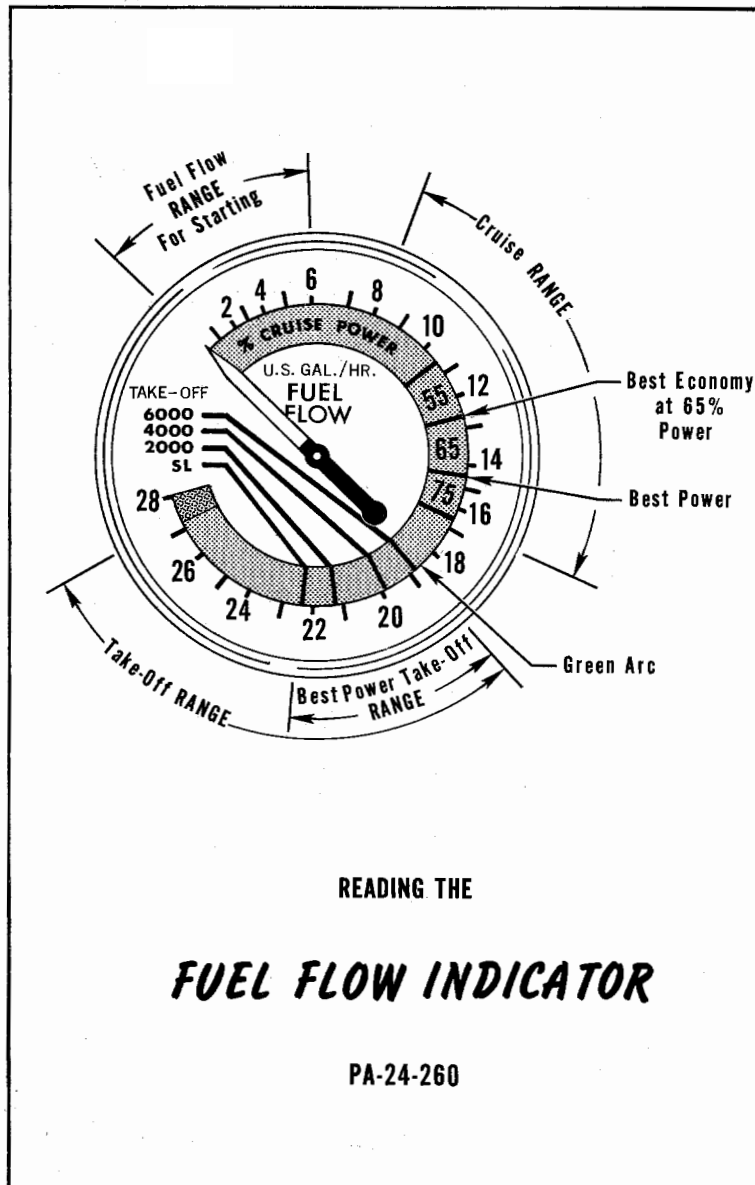

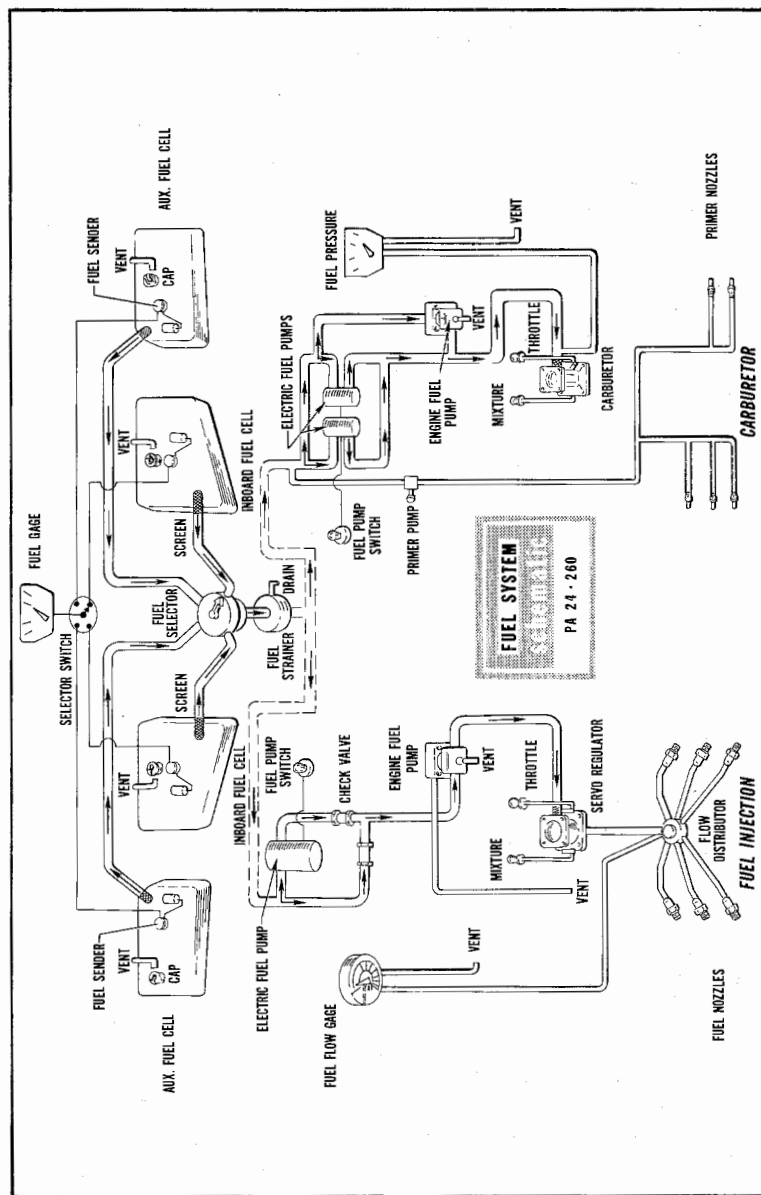
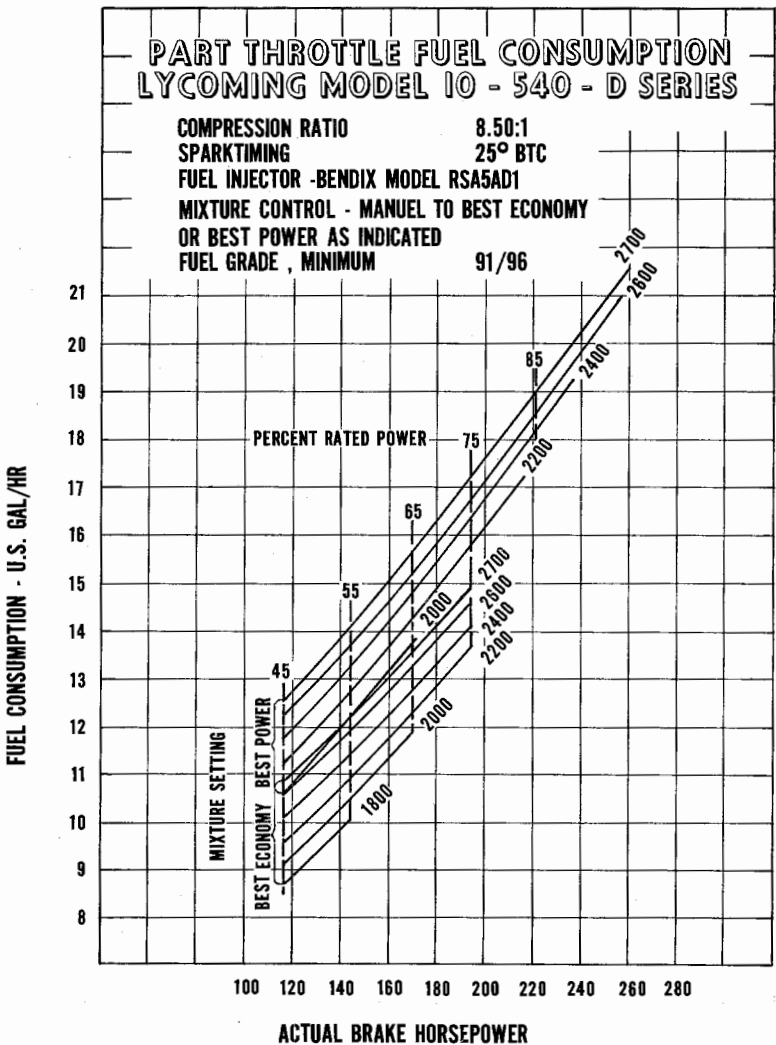

As optional equipment for the Comanche, a 30 gallon auxiliary fuel system is available. The system consists of two 15 gallon fuel cells installed in the wings just outboard of the main fuel cells. Use auxiliary fuel in level flight only.

The cells should be kept full of fuel during storage of the airplane to prevent accumulation of moisture and deterioration of the cells. For long term storage without fuel, the cells should be coated with light engine oil to keep the rubber from drying out.

During normal operation the fuel is drawn to the engine from the cells by a mechanically operated fuel pump located on the engine accessory section. In the event the engine driven fuel pump fails an electric auxiliary fuel pump is provided. This pump is operated during starting, take-offs, and landings.

The fuel selector and strainer units for the system are located between the front seats. Daily draining of the strainer is accomplished in the cockpit by opening the hinged access door located in the floorboard just aft of the fuel selector valve and moving the quick drain valve handle to full aft position. The general procedure for draining the fuel system is to open the strainer quick drain for a few seconds with the fuel cell selector on one cell, then change fuel selector to the opposite cell and repeat the process. The same process applies to the auxiliary fuel system. Allow enough fuel to flow to clear lines as well as the strainer. Positive fuel flow shut-off can be observed through the clear plastic tube

which carries fuel overboard.

Fuel quantity is indicated by one electric gauge located in the instrument cluster. This gauge will indicate the amount of fuel in the cell that is selected. An over-ride system is incorporated so that it is possible to check the amount of fuel available in the remaining cells without moving the selector handle to that cell position. This is accom-

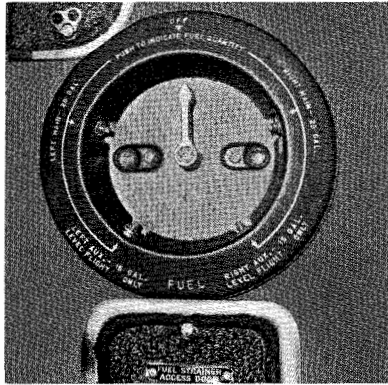

**Power Setting Table - Lycoming Model 10-540-D, 260 HP Engine**

Press. Std.	Alt. 1000 Feet	Temp. °F	143 HP - 55% Rated			169 HP - 65% Rated			195 HP - 75% Rated					
			Approx. RPM	Approx. Fuel 11.4 GPH	MAN. PRESS.	Approx. RPM	Approx. Fuel 12.7 GPH	MAN. PRESS.	Approx. RPM	Approx. Fuel 14.1 GPH	MAN. PRESS.			
			2100	2200	2300	2400	2100	2200	2300	2400	2200	2300	2400	2500
SL	59		22.3	21.5	20.7	19.8	25.3	24.1	23.2	22.2	26.9	25.8	24.8	24.0
1	55		22.1	21.3	20.5	19.6	25.1	23.9	22.9	22.0	26.6	25.5	24.5	23.7
2	52		21.9	21.0	20.3	19.4	24.8	23.6	22.7	21.8	26.3	25.3	24.3	23.5
3	48		21.7	20.8	20.0	19.2	24.5	23.4	22.5	21.6	26.0	25.0	24.0	23.2
4	45		21.4	20.6	19.8	19.0	24.2	23.1	22.2	21.4	25.7	24.7	23.8	22.9
5	41		21.2	20.3	19.6	18.8	24.0	22.9	22.0	21.1	25.4	24.4	23.5	22.7
6	38		21.0	20.1	19.4	18.6	23.7	22.6	21.7	20.9	-	24.1	23.3	22.4
7	34		20.7	19.9	19.1	18.4	23.5	22.4	21.5	20.7	-	-	23.0	22.2
8	31		20.5	19.6	18.9	18.2	-	22.1	21.2	20.5	-	-	-	21.9
9	27		20.3	19.4	18.7	18.0	-	21.9	21.0	20.3	-	-	-	-
10	23		20.0	19.2	18.5	17.7	-	-	-	-	-	-	-	-
11	19		19.8	18.9	18.2	17.5	-	-	-	-	-	-	-	-
12	16		19.6	18.7	18.0	17.3	-	-	-	-	-	-	-	-
13	12		-	18.5	17.8	17.1	-	-	-	-	-	-	-	-
14	9		-	-	17.5	16.9	-	-	-	-	-	-	-	-
15	5		-	-	-	17.3	-	-	-	-	-	-	-	-

To maintain constant power, correct manifold pressure approximately 0.17" Hg. for each 10° F variation in induction air temperature from standard altitude temperature. Add manifold pressure for air temperature above standard; subtract for temperatures below standard.

Power Setting Table - Lycoming Model O-540-E, 260 HP Engine

Press. Alt. 1000 Feet	Std. Alt. Temp. °F	143 HP - 55% Rated			169 HP - 65% Rated			195 HP - 75% Rated					
		Approx. Fuel 11.4 GPH RPM AND MAN. PRESS.			Approx. Fuel 12.7 GPH RPM AND MAN. PRESS.			Approx. Fuel 14.1 GPH RPM AND MAN. PRESS.					
		2100	2200	2300	2400	2100	2200	2300	2400	2200	2300	2400	2500
SL	59	21.7	20.8	20.2	19.5	24.6	23.6	22.7	21.9	26.3	25.3	24.4	23.8
1	55	21.5	20.6	20.0	19.3	24.4	23.3	22.5	21.7	26.0	25.0	24.1	23.5
2	52	21.3	20.4	19.8	19.1	24.1	23.1	22.2	21.5	25.7	24.8	23.9	23.3
3	48	21.0	20.1	19.6	18.9	23.8	22.9	22.0	21.2	25.4	24.5	23.6	23.0
4	45	20.8	19.9	19.4	18.7	23.6	22.6	21.8	21.0	25.1	24.2	23.3	22.7
5	41	20.6	19.7	19.2	18.4	23.3	22.4	21.5	20.8	24.8	23.9	23.0	22.5
6	38	20.4	19.5	18.9	18.2	23.1	22.2	21.3	20.6	-	23.7	22.8	22.2
7	34	20.2	19.3	18.7	18.0	22.8	22.0	21.1	20.4	-	-	22.5	22.0
8	31	20.0	19.1	18.5	17.8	22.6	21.8	20.8	20.1	-	-	-	-
9	27	19.8	18.8	18.3	17.6	-	21.6	20.6	19.9	-	-	-	-
10	23	19.6	18.6	18.1	17.4	-	-	20.3	19.7	-	-	-	-
11	19	19.4	18.4	17.9	17.2	-	-	-	19.5	-	-	-	-
12	16	19.2	18.2	17.7	17.0	-	-	-	19.3	-	-	-	-
13	12	-	17.9	17.4	16.8	-	-	-	-	-	-	-	-
14	9	-	17.7	17.2	16.6	-	-	-	-	-	-	-	-
15	5	-	-	17.0	16.4	-	-	-	-	-	-	-	-

To maintain constant power, correct manifold pressure approximately 0.17" Hg. for each 10° F variation in carburetor air temperature from standard altitude temperature. Add manifold pressure for air temperature above standard; subtract for temperatures below standard.

plished by depressing the red button (located on the fuel selector plate) under the desired fuel cell position. The fuel gauge will indicate the amount of fuel available in that cell. When the red button is released the indicating system will return to its normal operation.

When the fuel selector handle is not in a positive selector detent position, more than one fuel port will be open at the same time. It should be ascertained that the fuel selector is positioned in a detent, which can be easily felt when moving the handle through its various positions.

## ELECTRICAL SYSTEM

The Comanche electrical system includes 12 volt 75 amp alternator, providing power at all engine speeds, a transistorized voltage regulator, an over voltage relay and a 35 ampere hour battery. This advantage results in improved performance for radio and electrical equipment and longer battery life.

The battery and relays are mounted immediately aft of the baggage compartment. Access for service or inspection is obtained through a removable panel adjacent to the baggage door.

Electrical switches are located on the lower left side of the instrument panel. The circuit breakers, located below the electrical switches, automatically break the electrical circuit if an overload should occur. To reset the circuit breakers simply push in the reset button. It may be necessary to allow approximately two minutes before resetting the breakers. Corrective action should be taken in event of continual circuit breaker popping. It is possible to manually trip the breakers by pulling out on the reset button. The alternator circuit breaker, mounted on the same panel, is of the switchtype and should not be opened under any circumstances while the engine is running.

Standard electrical accessories, in addition to those already listed, include a geared starter, stall warning indicator,

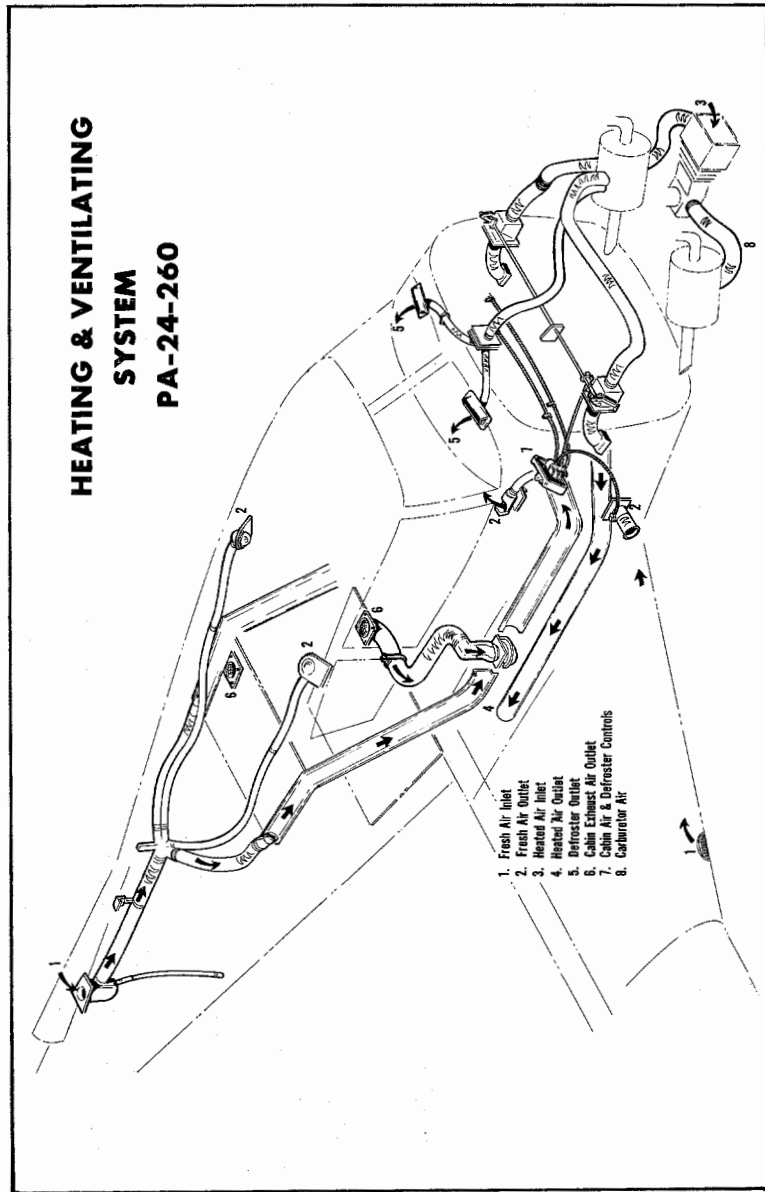

## PA -24 -260 COMANCHE

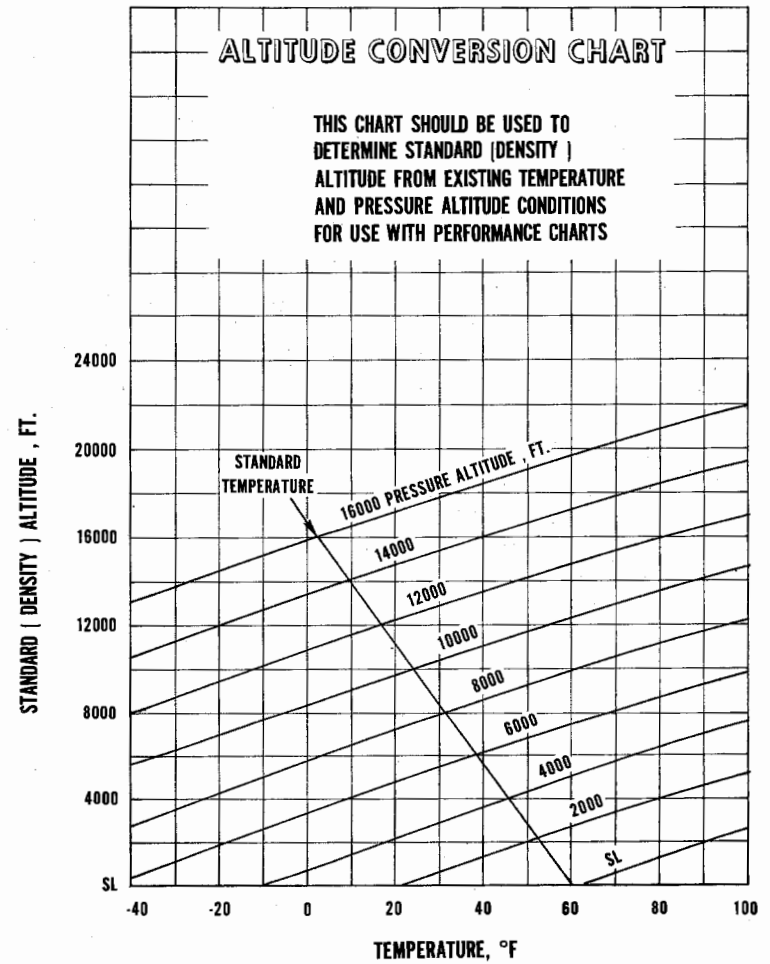

## PA-24-260 COMANCHE

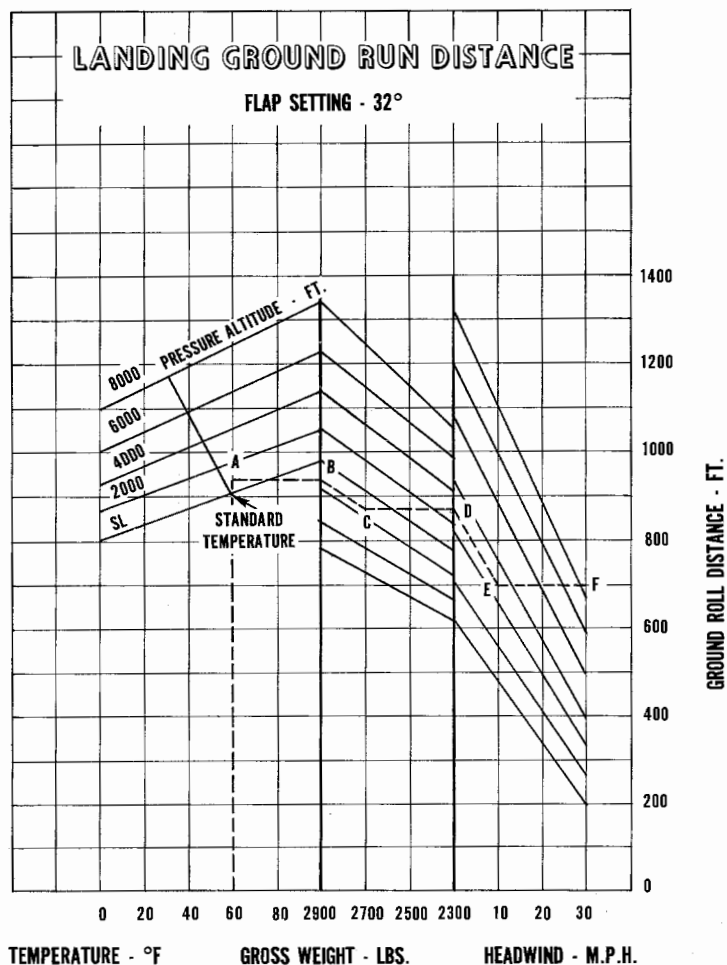

cigar lighter, ammeter and position lights. Glare ban instrument lighting and anti-collision light are offered as optional accessories. Circuit provisions are made to handle optional communications and navigational equipment.

Operation of the alternator system as far as visual indication to the pilot is the same as for a standard generator system. The ammeter, located in the upper right corner of the instrument panel, will give a constant indication of battery charge and/or discharge in case of a malfunction of the system. Should a malfunction of the voltage regulator occur that would cause a high voltage condition the over voltage relay will cut the alternator out of the system. Battery power will still be available to the bus bar.

### HEATING AND VENTILATING SYSTEM

There are four individual controls provided for regulating the heating, defrosting and ventilating air. The controls are located on the lower right side of the instrument panel in a console panel.

Heated air for the cabin interior is provided by a heater shroud attached to the left exhaust muffler. Fresh air is picked up at the air induction inlet at the front of the cowl and passed through the heater shroud into a control valve for distribution to the cabin.

Warm air for the defroster system is obtained directly from the heater shroud. The amount of air applied to the windshield is regulated with the control in the console. Caution should be used if it is necessary to operate the de-

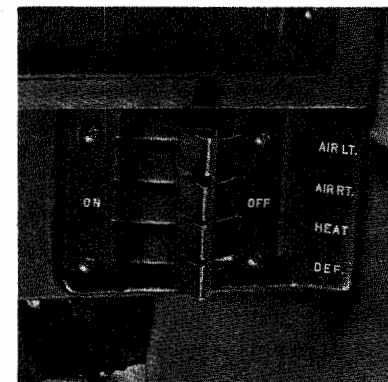

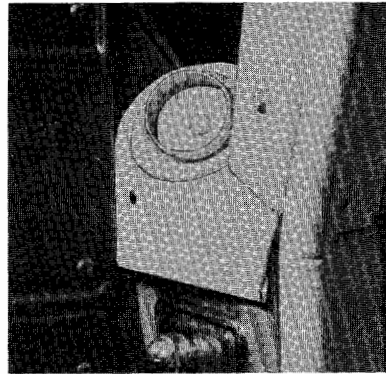

froster on the ground as prolonged application of heat to the windshield may cause distortion.

Fresh air for the cabin interior is picked up from two air inlets in the leading edge of each wing. The air passes through the wings to the wing root area and is discharged into the cabin near the floor just forward of the front seats.

In addition, two fresh air scoops are located on the dorsal fin. These provide air for two overhead ventilators in the rear seat area and two front seat ventilators located between the windshield posts and the instrument panel.

**INSTRUMENT PANEL**

The instrument panel in the Comanche is designed to accommodate the customary advanced flight instruments on the left side in front of the pilot and the engine instruments on the right side. Provision for extra instruments is made in both sections. Gyro instruments are shock mounted and all are accessible for maintenance by removing a portion of the fuselage cowl over the instruments.

The Artificial Horizon and the Directional Gyro in the flight group are vacuum operated through use of a vacuum pump installed on the engine. The Turn and Bank is an electrically operated instrument and serves as a standby for the Gyro's in case of vacuum system failure.

Radio units are installed in the center of the panel. Radio power supplies are mounted aft of the baggage compartment.

**PA-24-260  
COMANCHE**

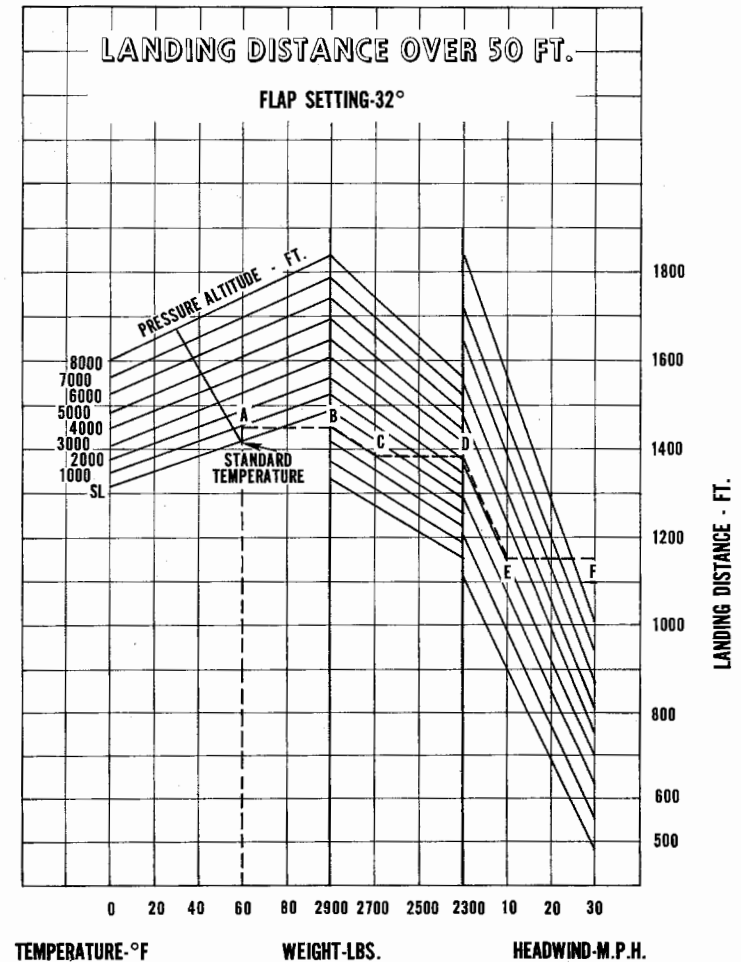



## PA-24 -260 COMANCHE

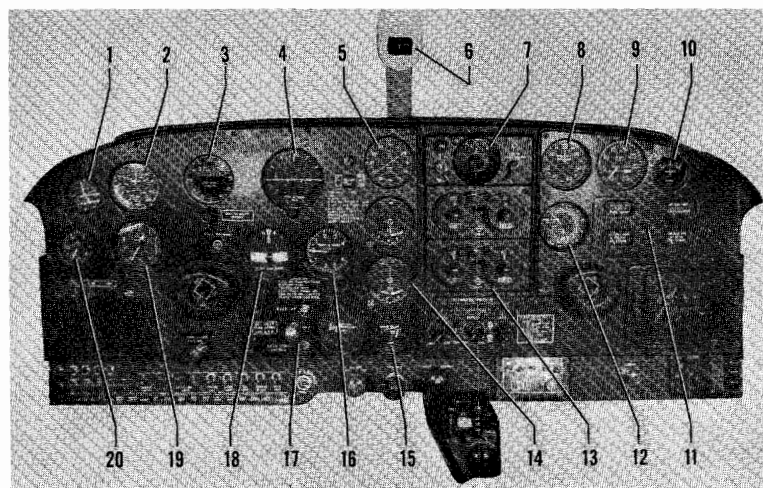
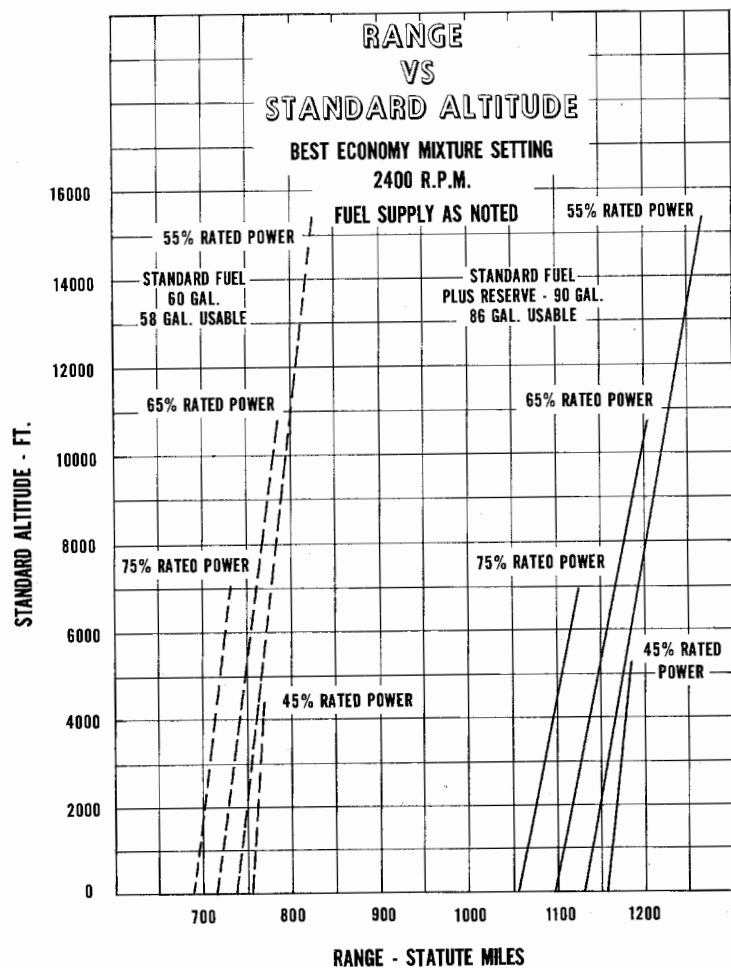

- |                       |                           |
|-----------------------|---------------------------|
| 1. Clock              | 11. Instrument Cluster    |
| 2. Airspeed           | 12. Fuel Flow Indicator   |
| 3. Directional Gyro   | 13. VHF Radio             |
| 4. Artificial Horizon | 14. Omni Indicator        |
| 5. ADF Radio Compass  | 15. Flap Indicator        |
| 6. Compass            | 16. Vertical Speed        |
| 7. ADF Radio          | 17. Landing Gear Selector |
| 8. Manifold Pressure  | 18. Turn and Bank         |
| 9. Tachometer         | 19. Altimeter             |
| 10. Ammeter           | 20. Suction Gauge         |

### VACUUM SYSTEM

Suction for the vacuum operated Gyro instruments is supplied by an engine driven (dry type) vacuum pump.

A vacuum gauge is installed in the instrument panel to provide a constant indication of vacuum source. Suction is indicated on the gauge in inches of mercury; normal operating range is 4.8 to 5.1 inches. The system is controlled by one adjustable regulator, located under the instrument panel. After initial adjustment the regulator will require very little attention.

## BAGGAGE COMPARTMENT

Maximum placarded weight of the baggage area is 200 pounds with 20 cubic feet of area available, accessible through a 20 x 20 inch door. Provision for securing cargo is provided by tie-down belts installed in the compartment. Attached to the top of the baggage compartment are provisions for stowing the tow bar. The key used in the ignition operates the lock on the baggage compartment door.

## SEATS

Front seats are adjustable so as to provide comfort and facilitate ease of entry and exit from the aircraft for pilot and passengers. They are easily removed by taking out the stops at the end of the mounting tracks and sliding the seats off their tracks.

The entire rear seat is removed quickly by disengaging the aft seat bottom tube from its attachment clamps, detaching the latches behind the top of the seat back, removing the center safety belt bolt, then lifting both the seat and the back as one unit from the cockpit.

## FINISH

All aluminum sheet components of the Comanche are carefully finished inside and outside to assure maximum service life. Both sides of all pieces are alodine treated, and are sprayed with zinc chromate primer. External surfaces are coated with durable acrylic lacquer in attractive high gloss colors. The application of primer to interior surfaces will prevent

## PA-24-260 COMANCHE

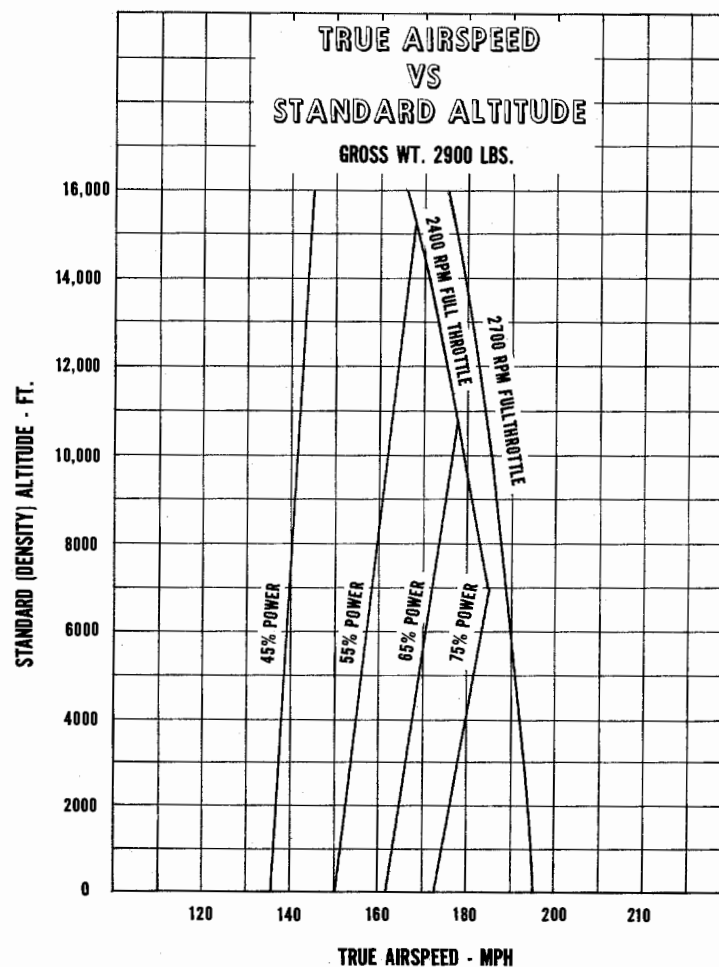

# PA-24-260 COMANCHE

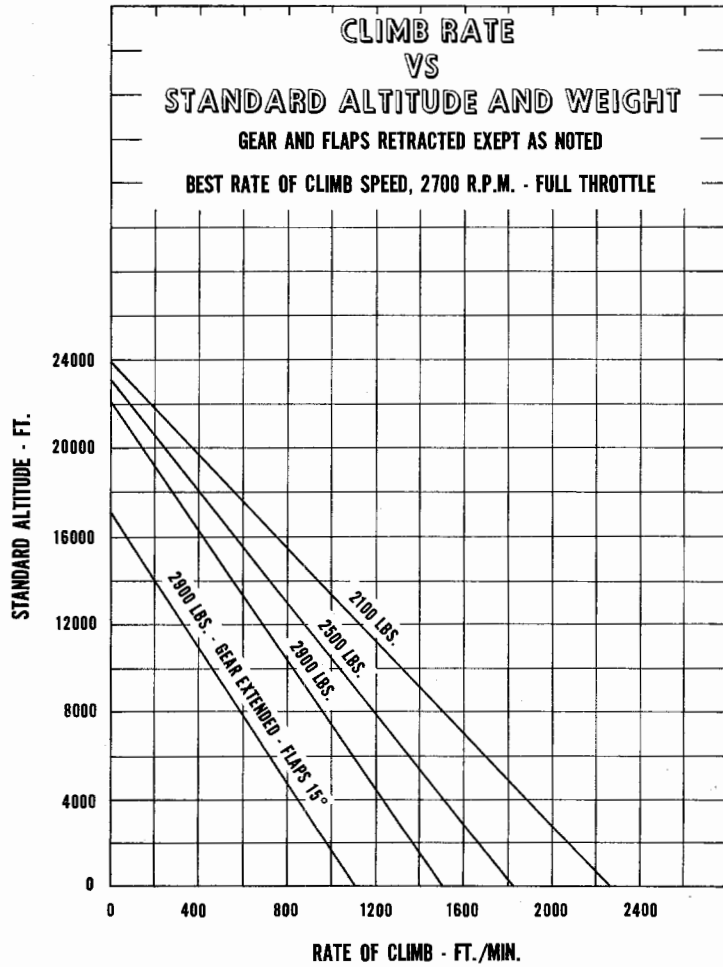

corrosion of structural and non-structural parts on the inside where there is no access for normal maintenance.

# PA-24-260 COMANCHE

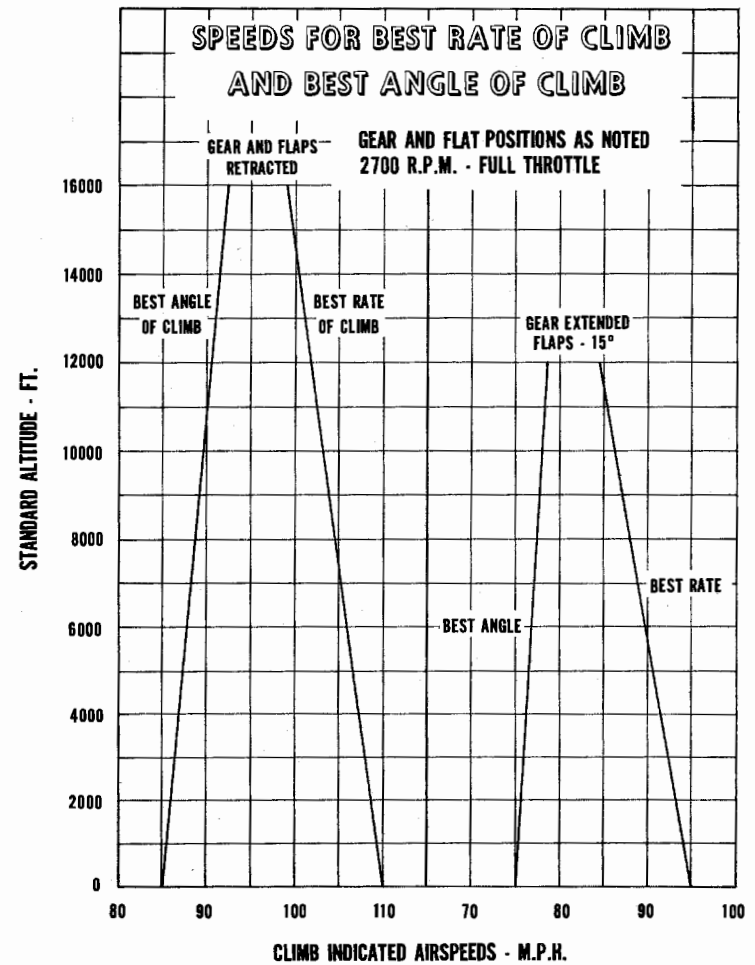

# PA-24-260 COMANCHE

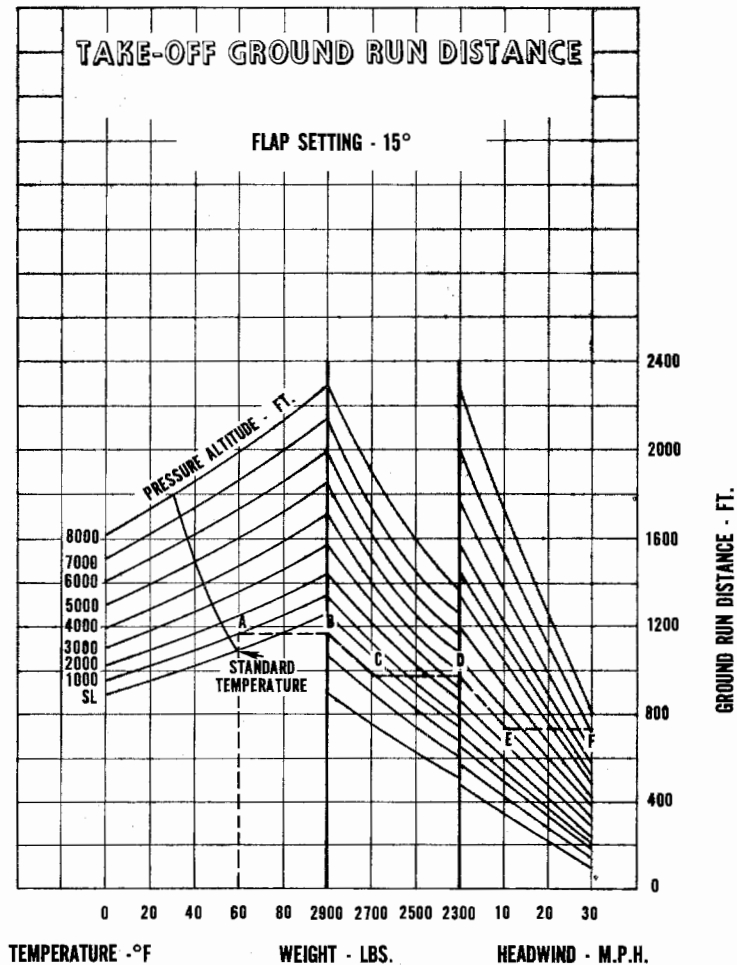

## SECTION III

### OPERATING INSTRUCTIONS

Preflight . . . . .	20
Starting Engine (Carburetor) . . . . .	21
Starting Engine (Fuel Injection) . . . . .	22
Warm-up and Ground Check . . . . .	23
Take-Off . . . . .	27
Stalls . . . . .	28
Climb . . . . .	29
Cruising . . . . .	29
Approach and Landing . . . . .	30
Stopping Engine . . . . .	31
Emergency Procedure . . . . .	32
Mooring . . . . .	34
Operating Tips . . . . .	34
Radio Operation . . . . .	36

# PA-24-260 COMANCHE

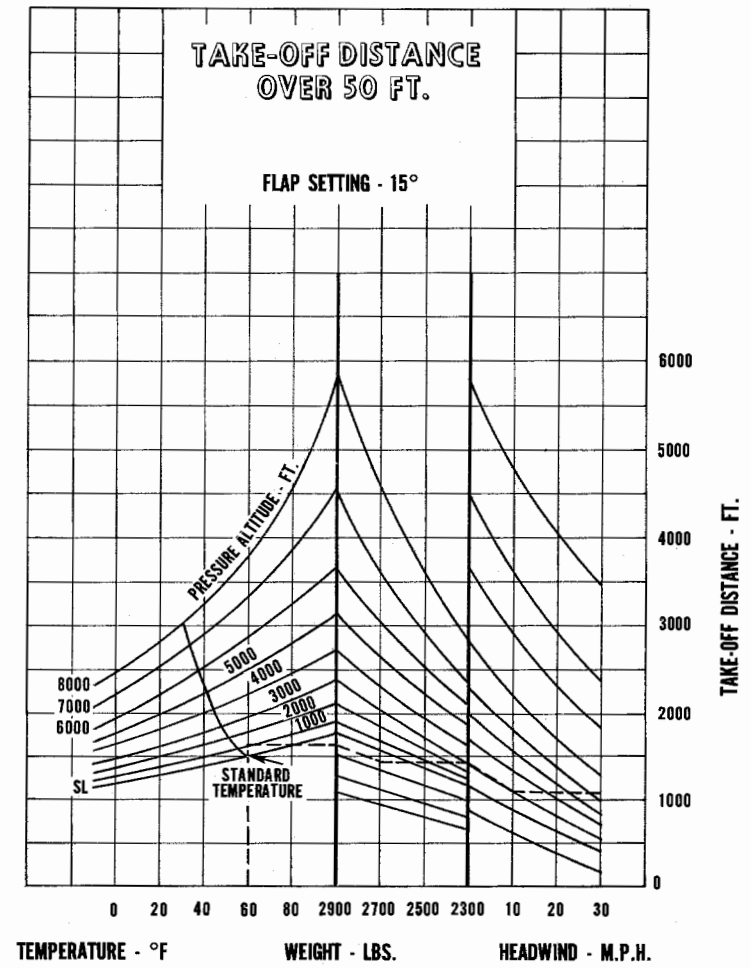

## SECTION III

### OPERATING INSTRUCTIONS

#### PREFLIGHT

The following safety procedure instructions must become an integral part of the pilot's operational routine and preflight inspection.

Below is an outline for preflighting the Comanche:

1. a. Ignition and battery switches are "OFF".
2. a. Check for external damage or operational interference to the control surfaces, wings or fuselage.
- b. Check for snow, ice, or frost on the wings or control surfaces.

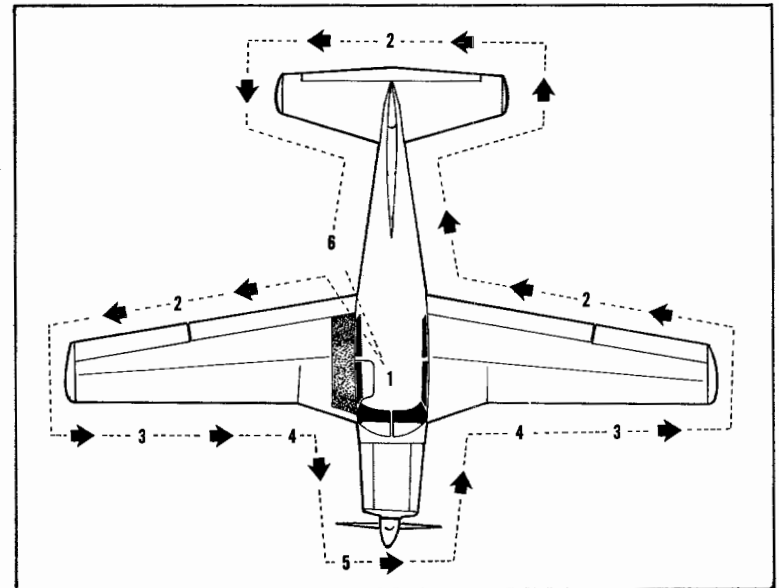

3. a. Check fuel supply.
- b. Check fuel cell caps and covers for security (adjust caps to maintain a tight seal).
- c. Fuel system vents open.
4. a. Landing gear shock struts properly inflated (approximately 2-3/4" piston exposed).
- b. Tires satisfactorily inflated and not excessively worn.
- c. Cowling, landing gear doors and inspection covers properly attached and secured.
- d. Propeller free of detrimental nicks.
- e. No obvious fuel or oil leaks.
- f. Engine oil at the proper level. (Insure dip stick is properly seated.)
5. a. Windshield clean and free of defects.
6. a. Tow-bar and control locks detached and properly stowed. Check that baggage door is secured.
7. a. Upon entering the airplane, ascertain that all controls operate normally.
- b. Check that the landing gear selector and the other controls are in their proper position.
- c. Close and secure the cabin door.
- d. Drain the fuel strainer.
- e. Check that required papers are in order and in the airplane.

### STARTING ENGINE (carburetor)

1. Fuel selector to the proper tank.
2. Mixture control full in, "RICH" position.
3. Carburetor heat control full in, "COLD" position.
4. Throttle open 1/4 inch.
5. Propeller control full in "INCREASE RPM".
6. Turn master switch to "ON" position.
7. Turn the auxiliary fuel pump switch "ON", listen for pump to operate and note fuel pressure indication.

## SECTION IV

### PERFORMANCE CHARTS

Take-off Distance over 50 Foot Barrier . . . . .	37
Take-off Ground Run Distance . . . . .	38
Speed For Best Rate and Angle of Climb . . . . .	39
Climb Rate vs Standard Altitude and Weight . . . . .	40
True Airspeed vs Altitude . . . . .	41
Range vs Standard Altitude . . . . .	42
Landing Distance over 50 Foot Barrier . . . . .	43
Landing Ground Roll . . . . .	44
Altitude Conversion Chart . . . . .	45
Power Setting Table, Lycoming O-540-E . . . . .	46
Power Setting Table, Lycoming IO-540-D . . . . .	47
Part Throttle Fuel Consumption, IO-540-D . . . . .	48
Fuel Flow Indicator , Lycoming IO-540-D . . . . .	49



8. Prime. When engine is cold (under 40° F) prime three to five strokes, if engine is warm do not prime.

### NOTE

If the engine is extremely cold, prime three to five strokes then pull the propeller through by hand. Insure the ignition switch is "OFF."

9. Check all radios for being "OFF."
10. Check the propeller area for being "CLEAR."
11. Turn the ignition switch to the "START" position and hold until engine starts. (Limit starter operation to 30 seconds) When the switch is released it will return to the "BOTH" position.

### NOTE

If the above procedure does not start the engine reprime and repeat the process. If the engine is overprimed, open the throttle and turn the engine over with the starter. If the engine still fails to operate, check for malfunctioning of ignition or fuel system.

## STARTING ENGINE (fuel injection)

Starting Engine When Cold:

1. Open throttle approximately 1/2 inch.
2. Turn on master switch and electric auxiliary fuel pump.
3. Move mixture control to full rich until an indication on the flow meter is noted, then turn pump off. (Engine is primed.)

4. Move mixture control to idle cut-off.
5. Ignition switches on and engage starter.
6. When engine fires move mixture control to full rich.

If engine does not fire within 5-10 seconds, disengage starter and reprime.

#### Starting Engine When Hot:

1. Throttle open approximately 1/2 inch.
2. Mixture in idle cut-off.
3. Electric auxiliary fuel pump off.
4. Engage starter. When engine fires advance mixture to full rich.

#### Starting Engine When Flooded:

1. Throttle full open.
2. Mixture in idle cut-off.
3. Electric auxiliary fuel pump off.
4. Engage starter. When engine begins to fire, push mixture to full rich, then retard throttle.

Starter manufacturers recommend that cranking periods be limited to thirty seconds with a two minute rest between cranking periods. Longer cranking periods will shorten the life of the starter.

## WARM UP AND GROUND CHECK

As soon as the engine starts, the oil pressure should be checked. If no pressure is indicated within thirty seconds, stop the engine and determine the trouble. In cold weather it will take a few seconds longer to get an oil pressure indication.

Warm-up the engine at 800 to 1200 RPM for not more than two minutes in warm weather, four minutes in cold weather. Avoid prolonged idling at low RPM as this practice may result

rienced. This condition may be eliminated by proper leaning of the mixture or by use of the electric fuel pump.

(13) A high fuel pressure indication on the fuel flow indicator is a possible indication of restricted air bleed nozzles.

## RADIO OPERATION

Communication and navigational equipment controls are located in the center of the instrument panel. Associated auxiliary switches are located on a separate panel below the control column on the lower right side of the instrument panel. Circuit breakers for the radios are located to the left of the main switch panel.

All sets are turned "ON" by the switch located on the control head of each particular unit, with the exception of the marker beacon and glide slope power switches which are located on the Audio Selector Switch Panel.

After power is supplied, the pilot may wish to operate one of the two transmitters by moving the transmitter selector switch to the proper position. The switch is located on the selector switch panel.

A separate three position audio selector switch is provided for each receiver. Each receiver audio output may be connected to either the speaker or the headset. In addition they may be placed on the "OFF" or standby position. To receive audio through the speaker from the Marker Beacon and DME UDI-2 the top Mark 12 must be in operation. Power from this radio is not required when the headphones are connected to the Marker Beacon or DME.

Two or more sets may be simultaneously connected to either the headset or speaker position by placing the selector switches in the desired combination. For example, the A.D.F. and the top Mark 12 may be selected to operate on the speaker and the lower Mark 12 may be selected for headset operation. If desired the pilot may listen to the speaker and the co-pilot the headset.

(3) On take-off, do not retract the gear prematurely. The airplane may settle and make contact with the ground because of lack of flying speed, atmospheric conditions or rolling terrain.

(4) The best speed for take-off is at about 65 MPH under normal conditions. Trying to pull the airplane off the ground at too low an airspeed will increase the take-off roll rather than decrease it.

(5) Although it is permissible to extend the landing gear at speeds up to 150 MPH, the loads on the landing gear extension motor and on the gear doors are much lower if slower speeds are used. For this reason, it is recommended that unless there is good reason to lower the gear at a higher speed, it should normally be extended at speeds below 125 MPH.

(6) The flaps can be lowered at airspeeds up to 125 MPH. To reduce flap operating loads, however, it is desirable to slow the airplane to 100 MPH or less before extending the flaps. At these reduced speeds, the load applied to the flaps is greatly reduced.

(7) During gear operation keep the floor area under the emergency gear lever clear. Restriction to movement of the lever will cause the gear motor circuit breaker to open.

(8) Always ascertain position of landing gear by the position of the emergency gear lever as well as the gear position lights.

(9) If, under unusual circumstances, the landing gear motor is apparently being overloaded and the circuit breaker opens repeatedly, the electric motor can be assisted by applying light hand pressure to the emergency gear lever.

(10) Before attempting to reset any circuit breaker, allow a two to five minute cooling off period.

(11) When landing and upon making contact with the ground on the main wheels, neutralize the rudder pedals, apply additional back pressure to the control wheel and retract the flaps. This gives best directional control on the ground and provides for full effectiveness of the brakes during the landing roll.

(12) In some instances when operating with fuel injection at altitudes over 10,000 feet, surging of the engine may be expe-

in fouled spark plugs. The magnetos should be checked at 2200 RPM and with propeller in high RPM, the drop should not exceed 125 RPM. The engine is warm enough for take-off when the throttle can be opened without the engine faltering.

The electric fuel pump(s) should be turned off after starting or during warm-up to make sure that the engine driven pump is operating by noting if fuel pressure or fuel flow is maintained. Prior to take-off the electric pump(s) should be turned on again to prevent loss of power during take-off should the engine driven pump fail.

In airplanes with carburetor induction engines, the carburetor heat should be checked during the warm-up to make sure the heat control operation is satisfactory and to clear out the carburetor if any ice has formed. It should also be checked in flight occasionally when outside air temperatures are between 20° F and 70° F to see if icing is occurring in the carburetor. In most cases when an engine loses manifold pressure without apparent cause, the use of carburetor heat will correct the condition.

When carburetor heat is applied, cold air entering the induction system is taken from the engine compartment, through the exhaust pipe shroud, then to the carburetor; it is not filtered. For this reason carburetor heat should not be used on the ground in dusty conditions except momentarily during the run-up. Dust taken into the intake system can damage the engine severely, and caution must always be exercised during ground operation to prevent dust from entering the engine.

The propeller control should be moved through its complete range during the warm-up to check for proper operation, then left in the full high RPM position. During cold weather operation the propeller should be cycled a minimum of three times to insure that warm engine oil has circulated throughout the entire system.

During the propeller check, as during other ground operations, care must be taken not to run-up the engine with the propeller over loose stones, cinders or other objects which can be picked up by the propeller, and which frequently cause extensive damage to the propeller blades.

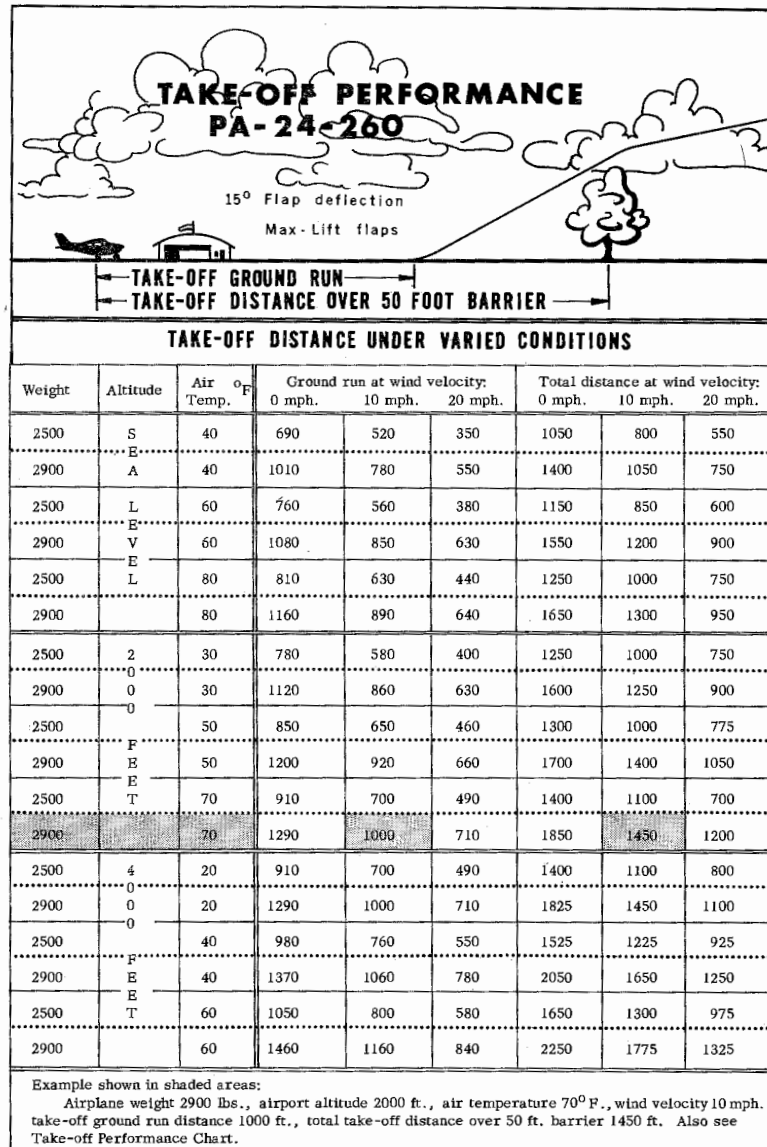

If changing to another tank does not restore the engine:

- (1) Check fuel pressure and turn on electric fuel pump, if off.
- (2) Push mixture control to full "RICH".
- (3) Apply carburetor heat. (Carburetor Installation)
- (4) Check ignition switch.

## MOORING

The Comanche should be moved on the ground with the aid of the nose wheel-tow-bar provided with each plane and stored in the baggage compartment on the bottom of the hat shelf.

Tie-down ropes for mooring the airplane can be fastened to the wing tie-down rings and the tail skid.

The aileron and elevator controls should be secured by means of the safety belt to prevent control surface damage. The rudder is held in position by its connections with the steerable nose wheel and does not need to be secured except under unusually high wind conditions.

## OPERATING TIPS

In the operation of the Comanche, as in that of any other type of aircraft, there are a few points of technique and information that apply particularly to this model. The following Operating Tips may be helpful in the operation of the Comanche:

- (1) Remember that when the navigation lights are on, the gear position lights are very dim.
- (2) Learn to trim for take-off so that only a very light back pressure on the wheel is required to lift the airplane off the ground.

normal electric operation, re-engage the electric motor to the landing gear extension torque tube by following the procedure given:

1. Place airplane on jacks.
2. Landing gear circuit breaker should be disengaged.
3. Pull landing gear emergency extension handle about half way back, allowing gear to hang partially extended.
4. Re-engage circuit breaker and with landing gear control switch move end of the electric motor drive shaft into position about half way back so that the slot in the drive shaft is near the mating pin on the torque tube.
5. Using the extension handle move the torque tube pin slightly back and forth until it can be engaged with the drive shaft slot, then push the parts together.
6. Lock the drive shaft to the torque tube by pulling the motor release arm full back to the normal locked position.
7. Check gear for proper operation.

#### Gear-Up Landing:

A gear-up landing should only be made during an emergency (1) when the surface is too soft or rough to permit a gear down landing; (2) when a field is too short for a gear-down landing, which might cause more damage through hitting obstructions than the gear-up landing would cause, (3) when a water landing is necessary.

In the event of a gear-up landing, make a normal approach as with gear-down, leave flaps up (to reduce flap and wing damage), close the throttle and cut the master and ignition switches during the flare out, turn the fuel selector off, and contact the ground at minimum speed.

#### Engine Failure:

The most common cause of engine failure is mismanagement or malfunction of the fuel system. Therefore, the first step to take after engine failure is to move the fuel selector valve to the tank not being used. This will often keep the engine running even if there is no apparent reason for the engine to stop on the tank being used.

LANDING PERFORMANCE PA-24-260								
32° Flap deflection Max-Lift flaps								
LANDING DISTANCE UNDER VARIED CONDITIONS								
Weight	Altitude	Air Temp.	Landing roll - max. braking effort			Total distance at wind velocity		
			0 mph.	10 mph.	20 mph.	0 mph.	10 mph.	20 mph.
2500	S	40	740	560	400	1260	1010	800
2900	A	40	880	680	510	1380	1120	900
2500	L	60	780	590	430	1290	1050	830
2900	E	60	920	720	550	1420	1160	930
2500	V	80	820	620	460	1320	1090	860
2900	L	80	960	760	590	1460	1200	960
2500	2	30	790	600	450	1310	1070	840
2900	0	30	920	730	560	1430	1160	940
2500		50	830	630	480	1340	1100	870
2900	F	50	950	760	580	1470	1200	950
2500	E	70	870	660	510	1370	1130	900
2900	T	70	980	790	620	1510	1240	1000
2500	4	20	830	640	470	1350	1100	900
2900	0	20	970	780	620	1480	1220	980
2500		40	870	680	510	1390	1130	920
2900	F	40	1010	810	640	1520	1260	1010
2500	E	60	920	720	550	1430	1160	940
2900	T	60	1050	840	660	1560	1300	1040

Example shown in shaded areas:  
Airplane weight 2900 lbs., airport altitude 2000 ft., air temperature 70° F., wind velocity 10 mph = stopping distance with maximum braking effort 790 ft., total landing distance from over 50 ft. barrier 1240 ft. Also see Landing Performance

**TAKE OFF**

Just before take-off the following should be checked:

- |                        |                          |
|------------------------|--------------------------|
| 1. Controls free       | 6. Carburetor heat off*  |
| 2. Flaps set           | 7. Fuel on proper tank   |
| 3. Tab set             | 8. Electric fuel pump on |
| 4. Propeller set       | 9. Engine gauges normal  |
| 5. Mixture set (rich*) | 10. Door latched         |

\*Carburetor induction system only.

In a smooth, steady motion of the throttle apply full power allowing the aircraft to accelerate in the three point attitude until the control surfaces become effective. Then apply slight back pressure on the control column to lift the nose wheel. Under normal take-off conditions the Comanche will leave the ground at about 65 MPH. Trying to pull the aircraft off before the proper speed is obtained will only prolong the take-off run. After the take-off has proceeded to the point at which a landing could no longer be made with the wheels down in the event of power failure, the gear should be retracted. As soon as the gear is up and sufficient altitude has been gained, reduce power to climb setting.

For a minimum take-off run the flaps should be lowered to the recommended 15 degrees. With the flaps in this position the take-off run will be reduced approximately 20 per cent.

Normally flaps are not used during crosswind take-offs. It is desirable to hold the nose wheel on the runway until a higher than normal take-off speed is obtained, then apply a definite but not abrupt back pressure to the control column to lift the aircraft from the runway. Once airborne, set up the required crab angle, retract the gear, and continue the climb-out.

During cold weather operation, when taking off from slush or water covered runways, allow the gear to remain down longer than usual so that any slush remaining on the gears will freeze and be broken away when the gear is retracted.

**EMERGENCY PROCEDURES****Manual Gear Extension:**

Manual landing gear extension is accomplished with the telescoping lever located directly aft of the nose wheel housing. This control is used to extend the gear if the electrical actuating system has failed, not to retract the gear manually without the use of the electric motor. With the electric motor disengaged from the gear torque tube, as required in extending the gear manually there is no mechanism for holding the gear in the "UP" position. The gear will not stay up if retracted manually.

Before proceeding with the emergency extension check the following:

1. Master and gear circuit breakers are in.
2. Master switch is on.
3. Navigation lights are off (daytime).

To extend the gear, remove the cover over the emergency disengage control located between the two front seats, and follow the instructions on the back of this cover as follows:

1. Airspeed not over 100 MPH.
2. Landing gear switch in the center off position if landing gear switch is a three position and in the gear down locked position if switch is a two position.
3. Disengage electric motor by pushing motor release arm forward through full travel.
4. Extend emergency handle to full length.
5. Push handle forward full travel to extend the landing gear.

After the gear has been extended manually, do not perform any unnecessary operation to the gear until the aircraft is placed on jacks.

To return the system to



During the approach, the landing gear can be lowered at speeds under 150 MPH, preferably on the downwind leg. The airplane should be trimmed to approach speed of about 85 MPH and flaps extended. The flaps can be lowered at speeds up to 125 MPH, if desired. The propeller should be set at full RPM or at a high cruising RPM to facilitate an emergency go-around if needed.

The amount of flap used during landings and the speed of the aircraft at contact should be varied according to the wind, the landing surface, and other factors. It is always best to contact ground at the minimum practicable speed consistent with landing conditions.

Normally, the best technique for short and slow landings is to use full flap and a small amount of power, holding the nose up as long as possible before and after ground contact. In high wind conditions, particularly in strong crosswinds, it may be desirable to approach the ground at higher than normal speeds with partial or no flap.

Maximum braking effect during short field landings can be obtained by holding full back on the control wheel with flaps up while applying brakes. This forces the tail down and puts more load on the main wheels, resulting in better traction.

On aircraft with a carburetor installed, carburetor heat should not be applied unless there is indication of carburetor icing, since the use of carburetor heat causes a loss in engine power which may be crucial in the event of a go-around, and can induce detonation in this situation.

## STOPPING ENGINE

During the landing roll, the flaps should be raised and the electric fuel pump turned off. After parking the radios should be turned off and the engine stopped by pulling the mixture control out to idle cut-off. The throttle should be left full aft to avoid engine vibration while stopping. Then the ignition and master switches must be turned off and the parking brake set.

In aircraft with fuel injection, during a normal take-off with full rich mixture the pointer on the fuel flow meter will stabilize between the sea level mark and the red line. This setting gives a slightly rich mixture to aid in fuel cooling the engine and is recommended for all normal take-offs at sea level.

When taking off from a high altitude field, (example 4,000 feet), the mixture should be leaned to obtain maximum power. This is done during the pre-take-off check. Apply full throttle, then move mixture control towards the lean position until the fuel flow pointer has stabilized at the 4,000 foot mark, located between the 19-1/2 and 20 gallon marks. Leave the mixture in this position and proceed with the take-off. Caution should be used when operating with the mixture leaned so that the engine is not overheated.

## STALLS

All controls are effective at speeds down through the stalling speed, and stalls are gentle and easily controlled.

STALL SPEED TABLE	
Configuration	(Power Off)
Flaps Up	70 MPH Calibrated Airspeed
Flaps Down (Full)	61 MPH Calibrated Airspeed
These figures are at gross weight of 2900 lbs.	

**CLIMB**

The best rate of climb speed at gross weight will be obtained at 110 MPH. The best angle of climb may be obtained at 85 MPH. At lighter than gross weight these speeds are reduced somewhat. For climbing enroute a speed of approximately 130 MPH is recommended. This will produce better forward speed and increase visibility over the nose during the climb.

**CRUISING**

The cruising speed of the Comanche is determined by many factors including power setting, altitude, temperature, weight, and equipment installed.

The normal recommended economy cruising power setting of the Comanche is at 65% power. At 10,000 feet this gives a True Airspeed of 177 MPH. This power setting is obtained under standard conditions at 2400 RPM and full throttle. Fuel consumption is approximately 12.7 gallons per hour total.

The optimum cruising speed of the Comanche at 7000' is 185 MPH. (See Power and Performance charts for power settings and performance under various conditions.)

The Lycoming engine in the Comanche can be cruised at any percent of power from 75% down. 2400 RPM is recommended for maximum cruise performance and lower RPM's, down to 1800, for more economical cruising conditions. Ordinarily an RPM setting should be selected which will give maximum smoothness.

To obtain the desired power set the manifold pressure and RPM according to the power setting table in this manual. After the desired power settings have been set up, adjust the mixture control.

Fuel injection engines best power setting is indicated by the fuel flow meter. The low side of the power setting, as

shown on the fuel flow meter, indicates best economy for that percent of power while the high side indicates best power. During climbing operation the servo regulator will sense the change in altitude and will automatically lean the mixture. For better economy manual leaning with the mixture control can also be accomplished if desired.

Use of the mixture control in cruising flight reduces fuel consumption significantly, especially at higher altitudes. The mixture should always be leaned during cruising operation over 5000 feet altitude, and normally also at lower altitudes at the pilot's discretion.

The continuous use of carburetor heat during cruising flight reduces power and performance. Unless icing conditions in the carburetor are severe, do not cruise with the heat on. Apply heat slowly and only for a few seconds at intervals determined by icing severity.

In order to keep the airplane in best lateral trim during cruising, the fuel should be used alternately from each tank. If auxiliary tanks are installed, it is suggested that the fuel in the two auxiliary tanks be used first.

**APPROACH AND LANDING****Before Landing Check List:**

1. Fuel selector on proper tank.
2. Mixture "RICH".
3. Propeller set.
4. Carburetor heat "OFF"\* (unless icing conditions exist).
5. Electric fuel pump "ON".
6. Landing gear "DOWN". (Under 150 M. P. H. check green light "ON", warning horn "OFF", gear emergency handle in "FORWARD" position.
7. Flaps as desired (under 125 M. P. H.)

\*Carburetor induction system only.



**SECTION II**  
**DESIGN INFORMATION**

Engine and Propeller . . . . .	5
Induction System . . . . .	6
Structures . . . . .	7
Landing Gear . . . . .	8
Control System . . . . .	10
Fuel System . . . . .	10
Electrical System . . . . .	13
Heating and Ventilating System . . . . .	15
Instrument Panel . . . . .	16
Vacuum System . . . . .	17
Baggage Compartment . . . . .	18
Seats . . . . .	18
Finish . . . . .	18

