

**Academia Sinica, Institute for Astronomy & Astrophysics
Greenland Telescope Project**

**Equipment Specification for the
Deice Controller Unit**

Document Number: 4-09-6500-0000

Revision: 0D

Date: 2018 May 8

Prepared by: Derek Kubo

Reviewed by:

Bill Liu

Ted Huang

George Nystrom

Pierre Martin-Cocher

EQUIPMENT SPECIFICATION FOR DEICE CONTROLLER UNIT
4-09-6500-0000

Revision History

Rev	Date	Author	Revision Description
0A	2018-04-03	D. Kubo	Original
0B	2018-04-17	D. Kubo	Cover – Reviewed by: removed “Ming-Tang Chen” and added “George Nystrom”
0B	2018-04-17	P. M. Cocher	1.1 added “The contractor is planning to add 12 ambient air temperature sensors, 3 per quadrant, in the future.”
0B	2018-04-17	P. M. Cocher	3.1.1 a) added “+ gnd”; b) added “+ gnd”; g) changed “48” to “60” and “144” to “180”
0B	2018-04-17	P.M. Cocher	3.3.6.1 removed “Note that due to power restrictions, only two (2) power modules will be commanded ON at any given time.” replaced with “Due to power restriction, the total sum of the RMS power used by the 8 power modules shall not exceed the total rating of 10 kW.”
0B	2018-04-17	P.M. Cocher	3.4 added e) Operating Altitude: 3400 meters; f) Non-Operating Altitude: 9000 meters (for air cargo transport)
0B	2018-04-17	T. Huang	3.3.1 c) Removed “1A” fuse size
0B	2018-04-17	D. Kubo	3.2.3.1 added “excluding flanges and handles”
0B	2018-04-17	B. Liu	3.3.5.1 changed “15 A” to “16 A”, removed (TBR).
0B	2018-04-17	D. Kubo	Added 3.5.3 Safety
0B	2018-04-17	J. Maute	Added 3.5.3.1 Unit Enclosure Door Interlock
0B	2018-04-17	J. Maute	Added 3.5.3.2 Ground Fault Monitor
0B	2018-04-17	G. Nystrom	Added 3.5.3.3 Smoke Ventilation
0B	2018-04-17	P.M. Cocher	Added 3.5.4 EMI and EMC
0B	2018-04-17	D. Kubo	Updated Table of Contents
0B	2018-04-17	D. Kubo	Updated Table 4.4 Verification Matrix
0C	2018-04-25	D. Kubo	2.0 added “j) National Electrical Code Reference, 1-28-7400-0000-0A-STD”
0C	2018-04-25	D. Kubo	3.2.1 added “(refer to section 2.0)”
0C	2018-04-25	D. Kubo	3.2.1 1 st paragraph, added “All input terminal contacts shall be labeled properly”
0C	2018-04-25	D. Kubo	3.2.1 2 nd paragraph, added “All output terminal contacts shall be labeled properly”
0C	2018-04-25	D. Kubo	3.2.1.2 3 rd paragraph, added “All input terminal contacts shall be labeled properly”
0C	2018-04-25	D. Kubo	3.2.1 3 rd paragraph, changed “48” to “60” and “144” to “180”
0C	2018-04-25	D. Kubo	3.3.5.1 changed “16 A” to “as required to protect the Deice System”
0C	2018-04-25	D. Kubo	3.3.5.2 changed “10 A” to “as required to protect the Deice System”
0C	2018-04-25	D. Kubo	Added “3.5.3.4 National Electrical Code Compliance” section
0C	2018-04-25	D. Kubo	4.4 Verification Matrix, 3.4 f) added “contractor to provide waiver”
0C	2018-04-25	D. Kubo	4.4 Verification Matrix added “3.5.3.4 NEC Compliance”
0C	2018-04-25	D. Kubo	4.4 Verification Matrix, 3.2.1 added “Labels” under Comments
0D	2018-05-08	D. Kubo	Figure 1.1 Fixed duplicate Zone-2 in QUAD-1
0D	2018-05-08	D. Kubo	3.2.1 2 nd paragraph, changed “eight 8” to “eight”
0D	2018-05-08	D. Kubo	3.2.1 3 rd paragraph, changed “connects” to “connections”
0D	2018-05-08	D. Kubo	Figure 3.2.3 add 2 nd hole for TEMP SENSORS

Table of Contents

1.0	Scope	5
1.1	Introduction	5
2.0	Applicable Document	6
3.0	Requirements	6
3.1	Item Definition	6
3.1.1	Unit Summary	7
3.2	Electrical and Mechanical Interfaces	8
3.2.1	Electrical Interfaces	8
3.2.2	Unit Location	9
3.2.3	Physical Characteristics	10
3.2.3.1	Size and Weight	11
3.2.3.2	Mounting Configuration	12
3.2.3.3	Enclosure Cooling	12
3.3	Electrical Design	12
3.3.1	Power Control, Quadrant-1	12
3.3.2	Power Control, Quadrant-2	15
3.3.3	Power Control, Quadrant-3	15
3.3.4	Power Control, Quadrant-4	15
3.3.5	Input Power Circuit Protection	15
3.3.5.1	480 VAC Disconnect Switch and Circuit Protection	15
3.3.5.2	120 VAC Circuit Protection	15
3.3.6	Remote Monitor and Control	17
3.3.6.1	Power Module Control	17
3.3.6.2	Current Monitor	17
3.3.6.3	Temperature Monitor	18
3.3.8	Local Monitor and Control	18
3.3.8.1	Power ON/OFF Switch	18
3.3.8.2	Emergency OFF Switch	18
3.3.8.3	Power ON Indicator	18
3.3.8.4	Heating Indicator	18
3.4	Environmental Conditions	18
3.5	Design and Construction	18
3.5.1	Identification and Marking	18
3.5.2	Maintainability	19
3.5.3	Safety	19
3.5.3.1	Unit Enclosure Door Interlock	19
3.5.3.2	Ground Fault Monitor	19
3.5.3.3	Smoke Ventilation	19
3.5.3.4	National Electrical Code Compliance	19
3.5.4	EMI and EMC	19
3.6	Engineering Drawings	19

EQUIPMENT SPECIFICATION FOR DEICE CONTROLLER UNIT
4-09-6500-0000

4.0	Requirements Verification	20
4.1	Pretest Inspection	20
4.2	Test Conditions	20
4.3	Failure Criteria	20
4.4	Verification Matrix	20
4.4.1	Inspection (I)	20
4.4.2	Analysis (A)	20
4.4.3	Demonstration (D)	20
4.4.4	Test (T)	20
4.4.5	Verification Level	21
	Test Verification Matrix	22

1.0 Scope

This specification establishes the requirements for the design, fabrication, assembly, test and quality assurance of the Deice Controller Unit, herein referred to as the unit, for the Greenland Telescope Project.

1.1 Introduction

The Greenland telescope, herein referred to as the GLT, consists of a 12-meter primary reflector dish that is composed of 264 aluminum reflector panels. A resistive heating element has been attached to the rear of each of these panels along with a power cabling system. The reflector, shown in *Figure 1.1*, is subdivided into four quadrants with inner and outer ring portions, each of which is subdivided into three zones.

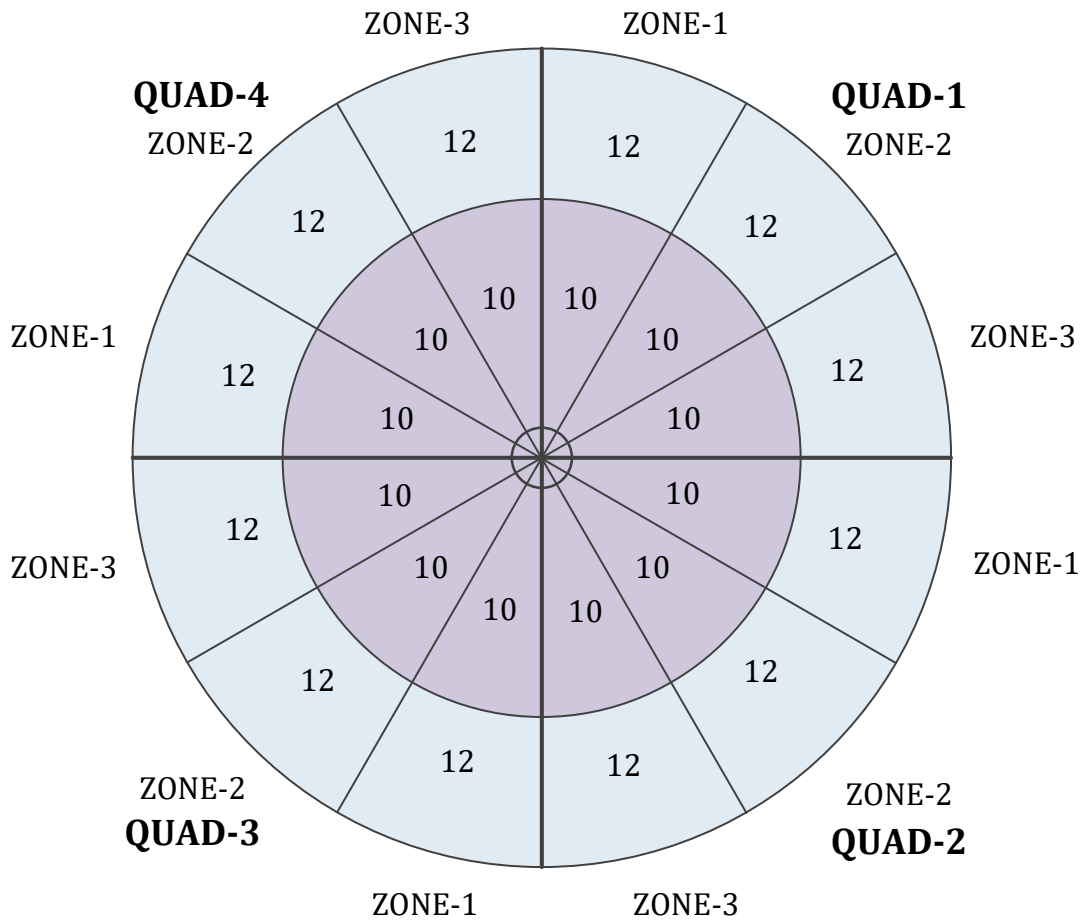

Figure 1.1. Front View of 12-meter Primary Reflector. Each quadrant is composed of 30 inner panels and 36 outer panels for a total of 264 panels. Each quadrant is separated into 3 zones and represent the 3 phases of the primary 480 VAC power.

Each individual resistive heating element has nominal resistances of 614.0 Ohms and 512.5 Ohms for the inner and outer panels, respectively. The outer panels have larger areas corresponding to lower resistances. Each panel is powered with one of three 277 VAC Line-to-Neutral phases of the primary 480 VAC 3-phase system. The nominal power dissipation for each inner and output panel heater is 125.0 W and 149.7 W, respectively. When powered on, a single quadrant corresponds to approximately 9.1 kW. In addition to the heating pads, there are 4 existing temperature sensors per zone, 12 per quadrant, totaling 48 for temperature monitoring. The contractor is planning to add 12 ambient air temperature sensors, 3 per quadrant, in the future.

2.0 Applicable Documents

The following documents are provided for reference purposes. In the event of a conflict between the contents of the referenced documents and those that are contained within this specification, the detailed requirements herein shall take precedence unless otherwise noted.

- a) Power Cable, Deice, Inner Panels, EXT 1, EXT 2, 1-06-6500-0100-0A-ASY
- b) Deicing System Heater and Temperature Sensor, Cable Installation Procedures, GLT-03.01.07.00-XXXX-A-PRO, Revision Draft, 2014-11-11
- c) Panel Heating System Assembly Procedure, GLT-03.01.03.07-1100-PRO, 2013-07-22
- d) Prototype Panel Heating Cover Assembly Report, CLT-03.01.03.07-XXXX-B-REP, Version C, 2015-02-16
- e) Omega SA1-RTD Temperature Sensor Datasheet, 1-09-6600-0000, Rev 0A
- f) Heating Element Resistances, Inner Panels, 3-09-6700-0001-0A-REP
- g) Heating Element Resistances, Outer Panels, 3-09-6700-0002-0A-REP
- h) Measured RTD Resistances, 3-09-6700-0003-0A-REP
- i) Deice System Design Report, 03-09-6700-0004-0A-DSN
- j) National Electrical Code Reference, 1-28-7400-0000-0A-STD

3.0 Requirements

The design of the unit shall comply with all the requirement of this section. Depending on the specific requirement, verification can be performed by inspection, analysis, demonstration, or test.

3.1 Item Definition

The unit shall consist of one wall mounted enclosure that provides the capability to selectively apply power to specified groups of heating elements and to monitor the resultant temperature effect on the panels. In addition, this unit shall be designed to

interface to a contractor provided PC via standard Ethernet network interface for control and monitor of the panel heating system.

3.1.1 Unit Summary

The unit shall provide the following functions and capabilities:

- a) Accept 480 VAC 3-phase input power via terminal blocks (4 contacts + gnd)
- b) Accept 120 VAC signal phase power input via terminal blocks (2 contacts + gnd)
- c) Accept input ground connection via terminal blocks (1 contact)
- d) Accept 2 Ethernet connections (1 spare), IEEE 802.3u (100Base-T), via RJ-45 connectors for control and monitor
- e) Provide 3 conductor connections for line, neutral and ground via terminal blocks to each of the 264 heating elements (792 contacts)
- f) Provide fuses in the LINE path to each of the 264 heating elements (264 fuses)
- g) Provide 3 conductor connections via terminal blocks or connectors to each of the 60 temperature sensors (180 contacts)
- h) Provide one circuit breaker for incoming 480 VAC 3-phase power
- i) Provide one circuit breaker for incoming 120 VAC single phase power
- j) Provide the capability to selectively heat the inner and outer portions of each of the four quadrants (total of eight separate heating groups)
- k) Provide one 3-phase current monitor for incoming 480 VAC 3-phase power
- l) Provide capability to shutdown all heating elements when any of the phase currents reach contractor specified current limit (via software control)
- m) Provide local emergency power off switch on front panel of unit
- n) Provide capability to shutdown all heating elements via network communications
- o) The unit shall be packaged within a metal enclosure that is designed to be wall mounted with maximum dimensions specified within this document
- p) The unit shall be designed to dissipate internally generated heat via conduction and/or convection

- q) The unit shall provide the capability to be monitored and controlled by a remote PC and includes monitoring of currents and RTD temperatures, and On/Off control of heating elements

3.2 Electrical and Mechanical Interfaces

The unit shall comply with the following electrical and mechanical interfaces.

3.2.1 Electrical Interfaces

Refer to *Figure 3.2.1* for the following discussion. The unit enclosure shall accept contractor provided 480-VAC 3-phase primary power for panel heating, 120-VAC single-phase auxiliary power, and Protective Earth (PE) Ground. The PE Ground shall be electrically tied to the metallic enclosure for safety. In compliance with the National Electrical Code (refer to section 2.0), all contractor provided cables for input power, 120 VAC and 480 VAC, are protected by 1-inch diameter (TBR) electrical conduit. All input terminal contacts shall be labeled properly.

The 24 Extension-1 cable assemblies that supply 277 VAC line to neutral power to the 264 panel heaters will be contained within eight separate 3-inch (TBR) diameter electrical conduits, 3 cable assemblies per conduit. The unit shall interface to the contractor supplied Extension-1 cable assemblies via 792 terminal contacts. All output terminal contacts shall be labeled properly.

There are 4 Extension-1 cable assemblies that provide connections to 60 temperature sensors on the dish. Each RTD (Resistance Temperature Detector) has 3 wires. The unit shall interface to the contractor supplied Extension-1 cable assemblies via 180 terminal contacts. All input terminal contacts shall be labeled properly.

Two network connections (one spare), IEEE 802.3u (100Base-T), via RJ-45 connectors shall be provided for remote monitor and control communications.

EQUIPMENT SPECIFICATION FOR DEICE CONTROLLER UNIT
4-09-6500-0000

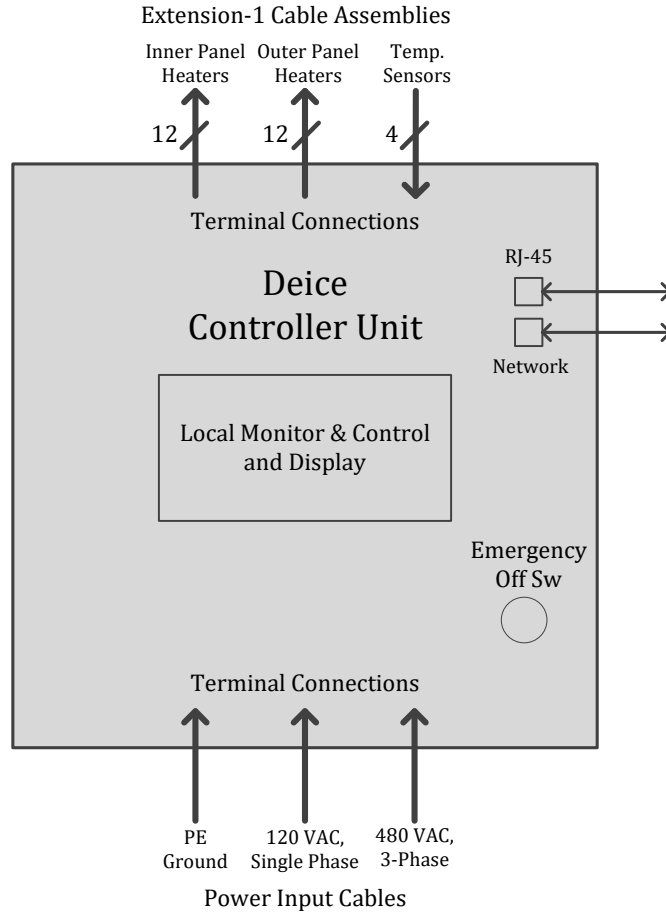

Figure 3.2.1. Electrical Interfaces. The unit shall provide physical terminal contact connections for incoming power and temperature sensors, and outgoing power to the dish heating pads. An RJ-45 connection(s) for network communication shall also be provided.

3.2.2 Unit Location

The unit shall be mounted next to the entrance door of the Left Side Container. An illustration of the antenna with the Left Side Container is shown in [Figure 3.2.2](#).

EQUIPMENT SPECIFICATION FOR DEICE CONTROLLER UNIT
4-09-6500-0000

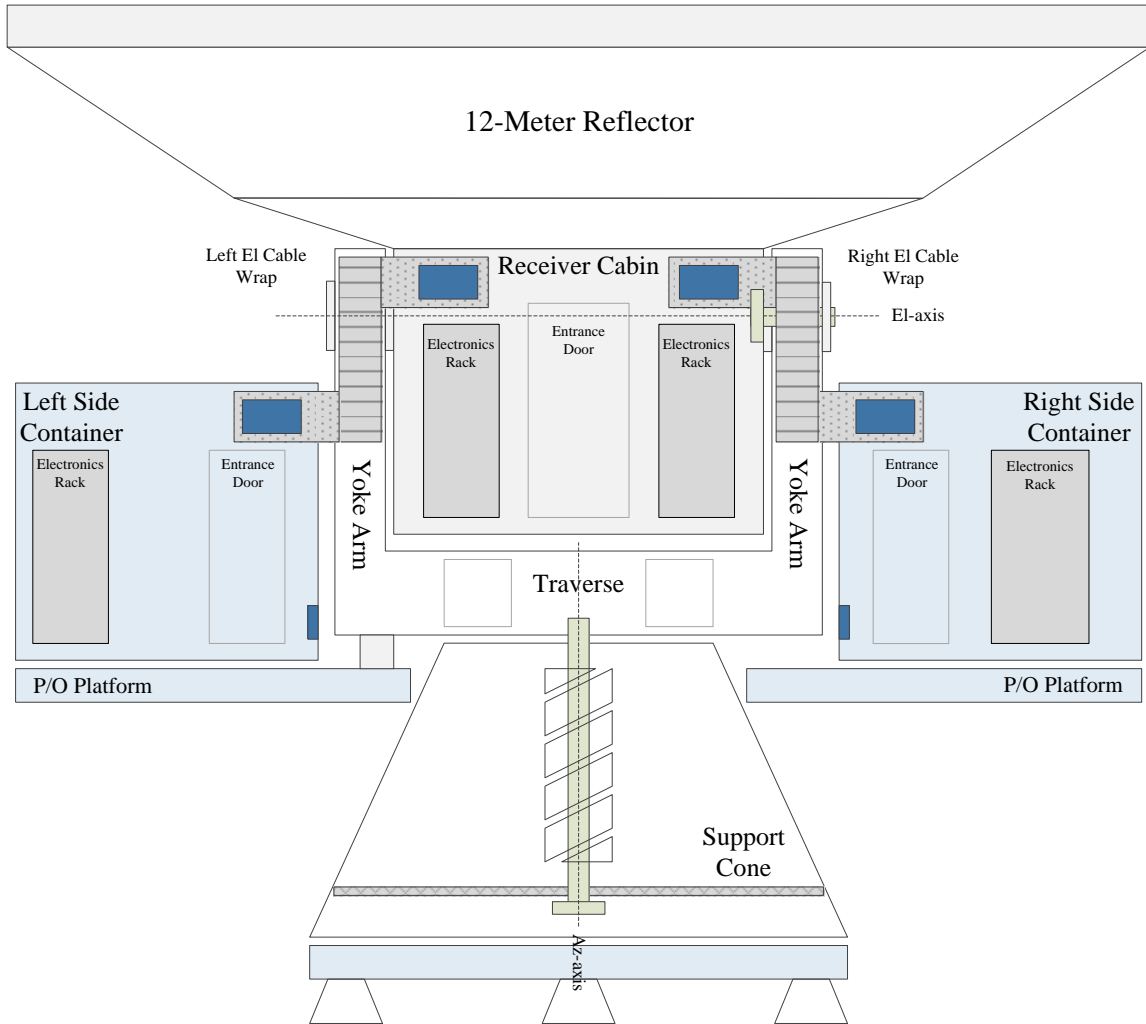

Figure 3.2.2. Deice Controller Unit Location. The unit will be housed in the Left Side Container of the antenna. 28 contractor supplied deice cable assemblies will be routed from the Deice Controller Unit through the Left Elevation Cable Wrap and to the rear of the 12-meter reflector.

3.2.3 Physical Characteristics

The unit shall be packaged within a single metallic enclosure and designed to sit on the floor and against the wall of the Left Side Container. A conceptual illustration of the Deice Controller Unit is shown in [Figure 3.2.3](#).

EQUIPMENT SPECIFICATION FOR DEICE CONTROLLER UNIT
4-09-6500-0000

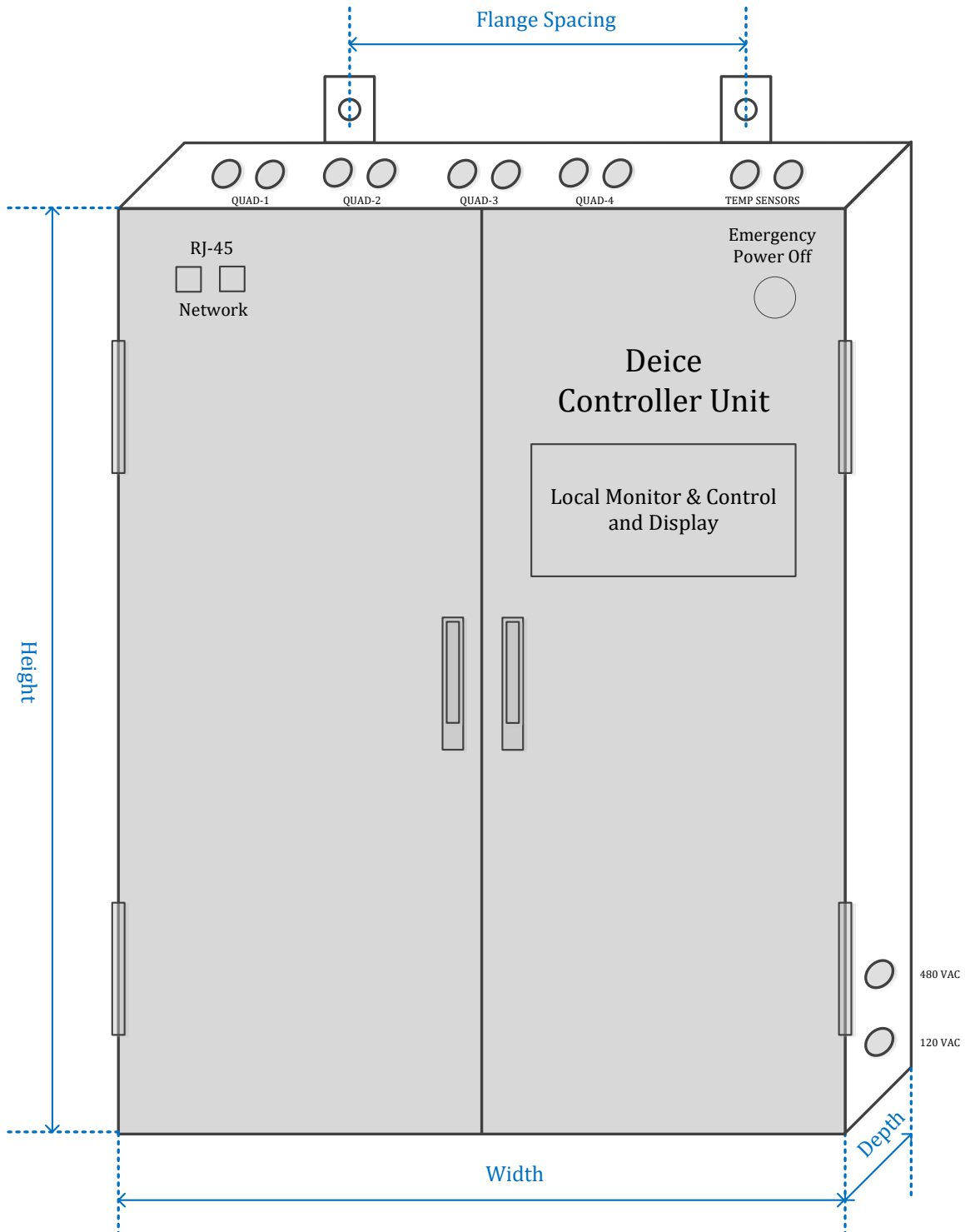

Figure 3.2.3. Conceptual Illustration of Deice Controller Unit. The eight holes at the top of the enclosure are for the Extension-1 cable assemblies for each Quadrant (6 power cable assemblies per quadrant). The two upper rightmost holes accept the four temperature cable assemblies (1 cable assembly per quadrant). Power entrance is through the lower right side of the unit.

3.2.3.1 Size and Weight

The maximum height, width, and depth shall not exceed 2.3 x 1.0 x 0.4 meters (TBR), excluding flanges and handles. The weight of the completed assembly shall not exceed 180 kg (TBR).

3.2.3.2 Mounting Configuration

The unit enclosure shall provide two (2) mounting flanges capable of accepting M10 (TBR) mounting bolts. The center-to-center spacing of the flange mounting holes shall be TBD meters.

3.2.3.3 Enclosure Cooling

The unit shall be capable of dissipating all of its internally generated heat by a combination of conduction and convection. If deemed necessary, forced air cooling shall be employed to maintain internal component and module temperatures within the rated specifications.

3.3 Electrical Design

The unit shall comply with the following electrical design parameters.

3.3.1 Power Control, Quadrant-1

An electrical schematic for the Quadrant-1 Inner and Outer heating panels is provided in *Figure 3.3.1A* and *Figure 3.3.1B*, respectively. It is noted here that the nomenclature for Line-1 (R), Line-2 (S), Line-3 (T), Neutral, and Ground are denoted as L1, L2, L3, N, and G, respectively. The following requirements shall be adhered to:

- a) Power Control Module – This module controls the LINE power, ON or OFF, simultaneously to the heating pads in the three zones. A requirement of this module is that the switching of the shall power take place at the voltage zero crossing of 60 Hz power cycle to prevent the generation of power line harmonics.
- b) Power Control Command – Internal design parameter, not specified.
- c) Protection Fuse - A SLOW BLOW replaceable inline fuse shall be provided for each of the heating pads to protect the Extension-1 and Extension-2 cable assemblies in the event of a short circuit along the routing path.
- d) Terminal Connection – Provide terminal connections for LINE, NEUTRAL, and GROUND for each of the panel heaters, 30 heaters for the inner panels, 36 heaters for the output panels.

EQUIPMENT SPECIFICATION FOR DEICE CONTROLLER UNIT
4-09-6500-0000

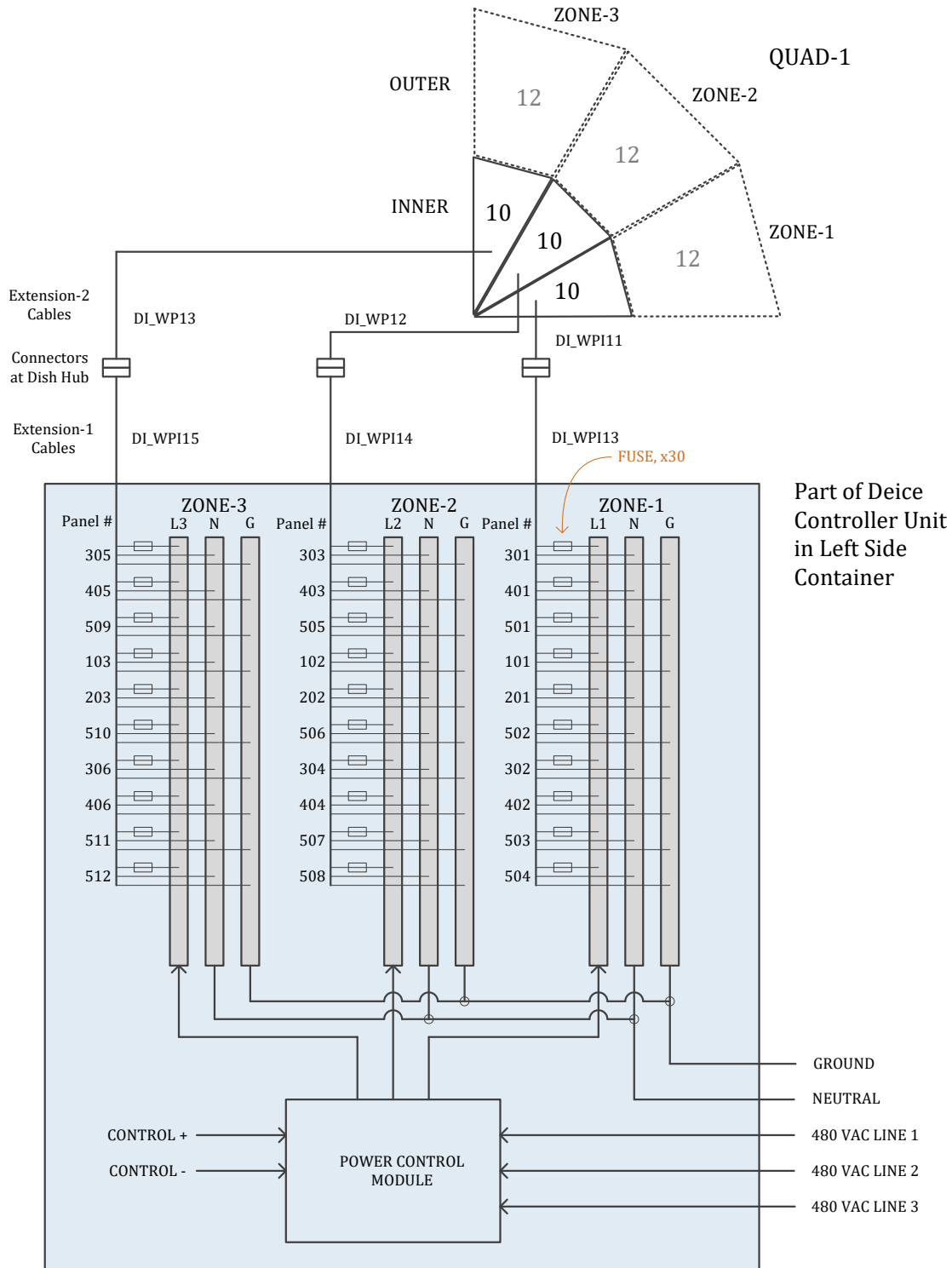

Figure 3.3.1A. Power Control, Quadrant-1 Inner Panels. The power control module provides switching of the three incoming lines to the power bus terminals. An output fuse is provided for each of the individual panel heaters. The Extension-1 cable assemblies are attached directly to the power bus terminals within the Deice Controller Unit enclosure.

EQUIPMENT SPECIFICATION FOR DEICE CONTROLLER UNIT
4-09-6500-0000

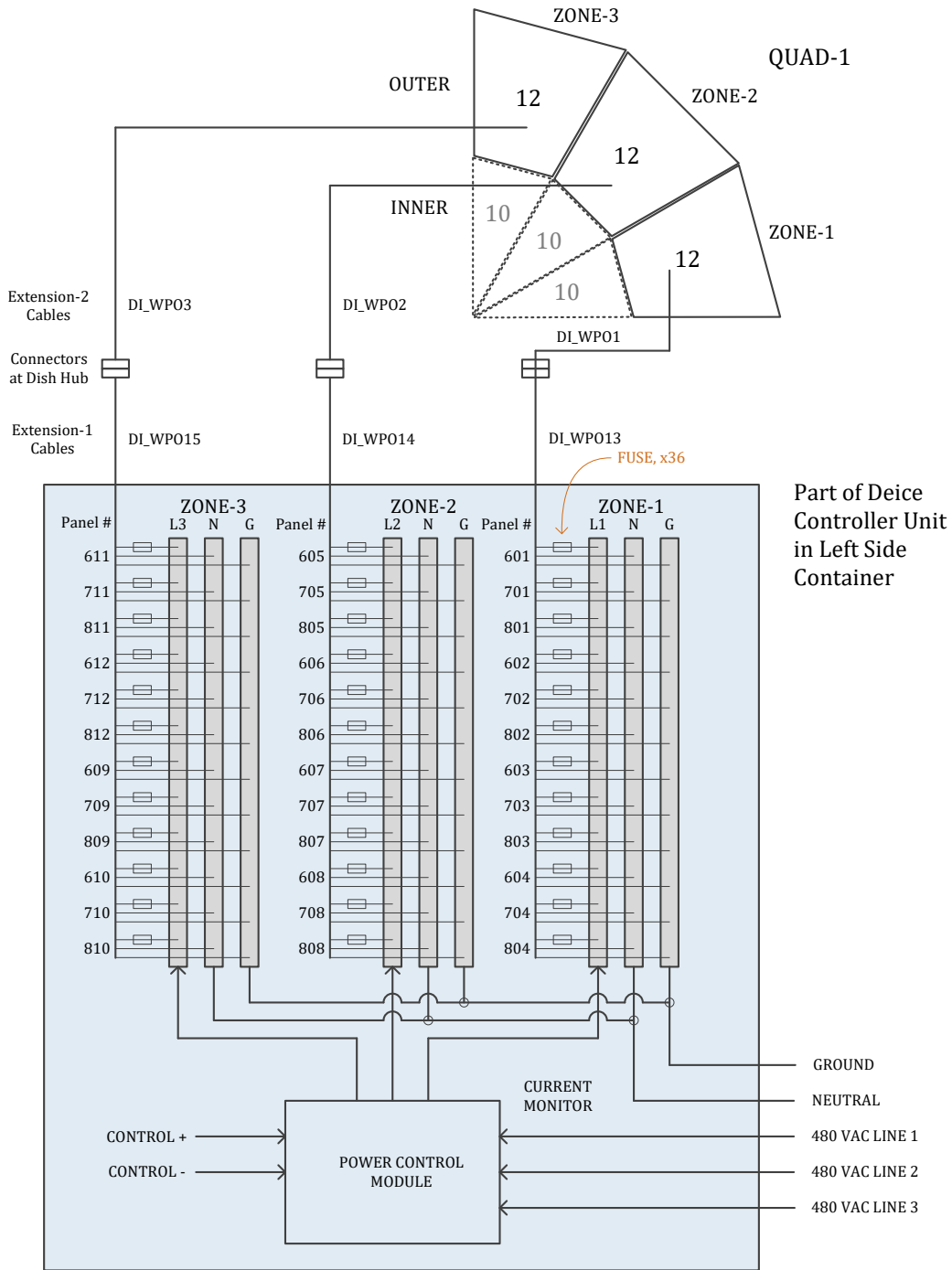

Figure 3.3.1B. Power Control, Quadrant-1 Outer Panels. The power control module provides switching of the three incoming lines to the power bus terminals. An output fuse is provided for each of the individual panel heaters. The Extension-1 cable assemblies are attached directly to the power bus terminals within the Deice Controller Unit enclosure.

3.3.2 Power Control, Quadrant-2

The same requirements for Quadrant-1 apply to Quadrant-2. Refer to [GLT-03.01.07.00-XXXX-A-PRO](#) document, page 42-54.

3.3.3 Power Control, Quadrant-3

The same requirements for Quadrant-1 apply to Quadrant-3. Refer to [GLT-03.01.07.00-XXXX-A-PRO](#) document, page 42-54.

3.3.4 Power Control, Quadrant-4

The same requirements for Quadrant-1 apply to Quadrant-4. Refer to [GLT-03.01.07.00-XXXX-A-PRO](#) document, page 42-54.

3.3.5 Input Power Circuit Protection

3.3.5.1 480 VAC Disconnect Switch and Circuit Protection

A 480 VAC 3-phase emergency disconnect switch and separate circuit breaker shall be provided at the incoming power input to the unit. The trip current for the circuit breaker shall be rated as required to protect the Deice System. Refer to [Figure 3.3.5.1](#).

3.3.5.2 120 VAC Circuit Protection

A 120 VAC single-phase circuit breaker shall be provided at the incoming power input to the unit. The trip current for the circuit breaker shall be rated as required to protect the Deice System.

EQUIPMENT SPECIFICATION FOR DEICE CONTROLLER UNIT
4-09-6500-0000

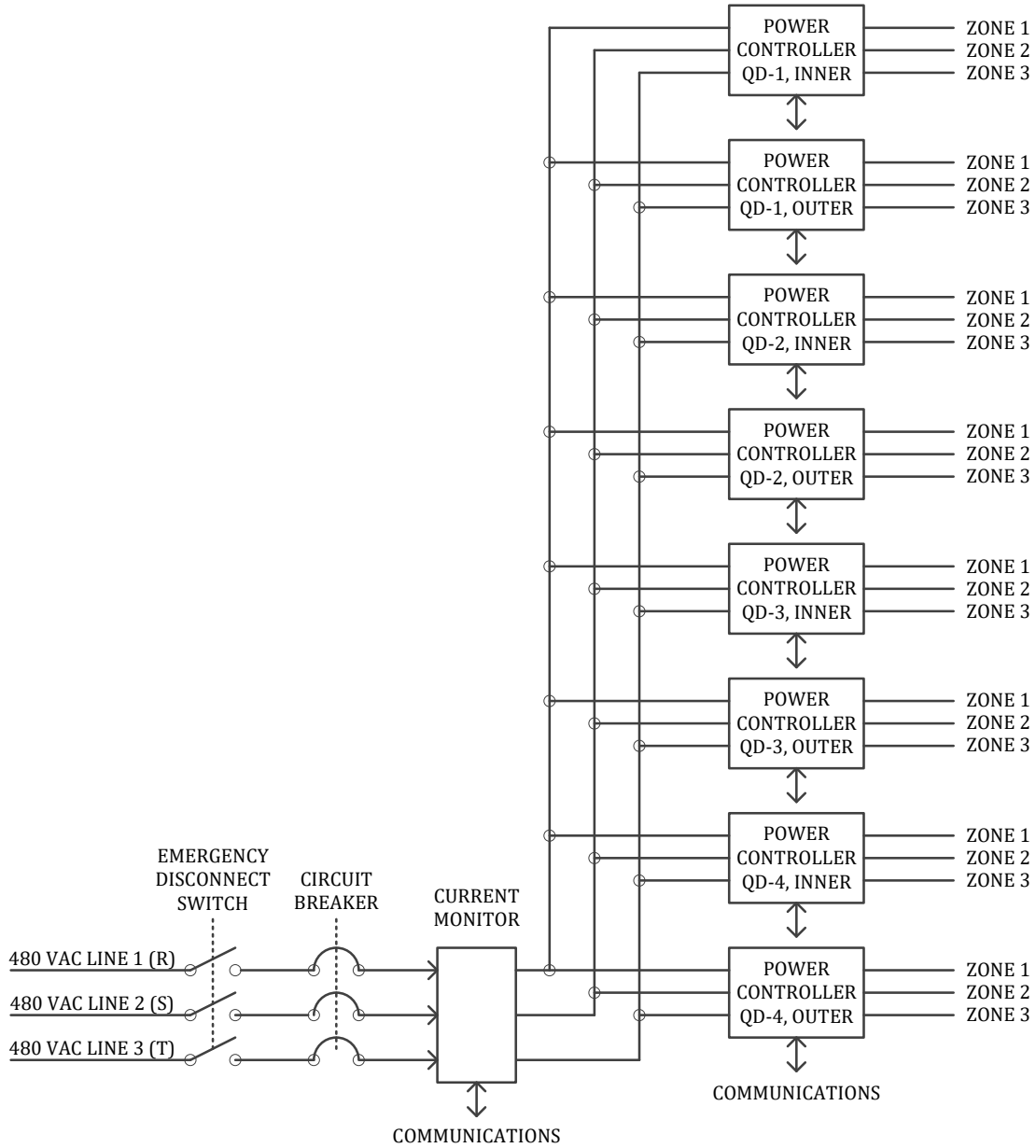

Figure 3.3.5.1. Input Power Switch and Circuit Breaker. A remotely accessible current monitor shall be provided.

3.3.6 Remote Monitor and Control

Figure 3.3.6 illustrates separate internal communications within the unit and is a non-specified internal design parameter (e.g., RS-232, RS-485, USB, etc.). However, the external communications to and from the unit is specified as 100Base-T Ethernet. This Ethernet interface shall be used to communicate to a contractor provided PC (Linux or Windows OS) via network communications for remote monitor and control as described in the following paragraphs.

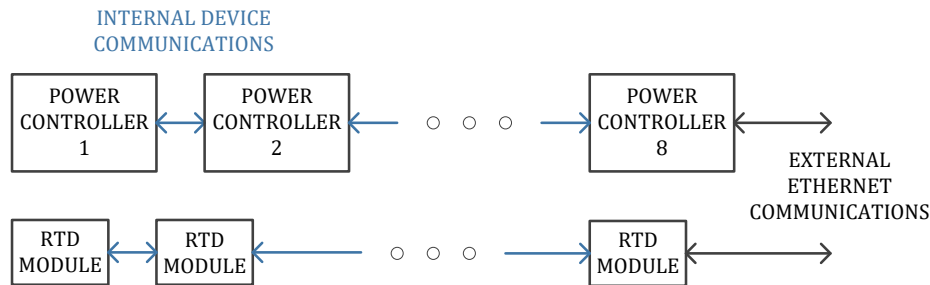

Figure 3.3.6. Internal and External Communications. This figure illustrates separate external Ethernet communications for power control and RTD temperature sensor monitoring.

3.3.6.1 Power Module Control

The unit shall accept remote commands from the contractor provided PC to selectively turn ON/OFF any of the eight (8) power controller modules shown in *Figure 3.3.5*. Due to power restriction, the total sum of the RMS power used by the 8 power modules shall not exceed the total rating of 10 kW.

3.3.6.2 Current Monitor

The unit shall provide the capability to remotely monitor the total deice system current consumption. The current monitor is shown in *Figure 3.3.5* as a separate module, however, this function may be included within the power controller modules.

3.3.6.3 Temperature Monitor

The unit shall provide the capability to remotely monitor 48 individual 3-wire RTD (Resistance Temperature Detector) sensors located on the dish.

3.3.8 Local Monitor and Control

The unit shall provide the following local monitor and control capabilities.

3.3.8.1 Power ON/OFF Switch

The unit shall provide a master power ON/OFF switch within in the enclosure. This may consist of the circuit breaker shown in [Figure 3.3.5](#).

3.3.8.2 Emergency OFF Switch

The unit shall provide a readily accessible Emergency OFF switch on the front panel.

3.3.8.3 Power ON Indicator

The unit shall provide an illuminated indicator to indicate the unit is powered on.

3.3.8.4 Heating Indicator

The unit shall provide indication of the status of each of the eight power controllers via LED or other display means.

3.4 Environmental Conditions

The unit shall be designed and constructed to withstand any combination of the conditions described below without damage or performance degradation.

- | | |
|------------------------------|---------------------------------------|
| a) Operating Temperature: | 0 to +45 C |
| b) Non-Operating Temperature | -20 to +60 C |
| c) Operating Humidity: | 5 to 75%, non condensing (TBR) |
| d) Non-Operating Humidity: | 5 to 90%, non-condensing (TBR) |
| e) Operating Altitude: | 3200 meters |
| f) Non-Operating Altitude: | 9000 meters (for air cargo transport) |

3.5 Design and Construction

The design and construction of the unit shall meet the following design and construction requirements.

3.5.1 Identification and Marking

The following identification and marking shall be provided on the unit.

- | | |
|-----------------------|-----------------------|
| a) Unit Name: | Deice Controller Unit |
| b) Part Number: | 1-09-6500-0001 |
| c) Manufacturer Name: | Manufacturer Name |

3.5.2 Maintainability

The unit shall be designed for maintainability in the field without removal of the unit itself from the telescope. Modules that comprise the unit shall be field replaceable with spares by qualified electrical technicians.

3.5.3 Safety

The design and construction of the unit shall comply with the following safety requirements.

3.5.3.1 Unit Enclosure Door Interlock

Due to the potential dangers of 480 VAC, the enclosure door or front panel shall have an interlock switch that de-energizes the 480-VAC power to the unit when opened. This de-energizing circuit may have an override to allow authorized personnel to conduct tests while energized.

3.5.3.2 Ground Fault Monitor

The unit shall provide the capability to sense and remotely report a ground fault (leakage current) from any of the 480 VAC 3-phases to ground.

3.5.3.3 Smoke Ventilation

The unit enclosure shall be ventilated to the air within the left side container such that any smoke generated within the unit due to overheating or fire would be detected by the existing contractor supplied smoke detector system.

3.5.3.4 National Electrical Code Compliance

The design and construction of the unit shall be in accordance to the National Electrical Code (NEC) guidelines provided in section 2.0.

3.5.4 EMI and EMC

The design and construction of the unit shall comply with standard EMI and EMC design practices including the following.

- a) Grounded metallic enclosure
- b) Grounded metallic cover or door
- c) Metallic screens or grills over vent openings
- d) EMI filters on incoming power lines (480 VAC, 120 VAC)

3.6 Engineering Drawings

The following drawings and documentation shall be provided to the contractor upon delivery of the unit.

- a) Electrical Schematics
- b) Mechanical Drawings
- c) Bill of Materials List
- d) Operation Manual

4.0 Requirements Verification

The requirements for the unit shall be verified according to the following criteria.

4.1 Pretest Inspection

The unit shall be physically examined for conformance to the applicable engineering drawings prior to testing.

4.2 Test Conditions

All tests will be performed under normal laboratory conditions at ambient room temperature.

4.3 Failure Criteria

The unit will exhibit no failure, malfunction, out-of-tolerance performance, or degradation as a result of examinations and tests specified herein. Any such failure, malfunction, out-of-tolerance performance, or degradation will be cause for rejection.

4.4 Verification Matrix

The applicable verification method for each requirement of section 3.0 is indicated in [Table 4.4](#). Verification that the unit performs in accordance with the specification shall be accomplished by the methods of inspection, analysis, demonstration, and test as defined below.

4.4.1 Inspection (I)

Inspection consists of the visual examination of equipment, documentation (e.g., engineering drawings, schematics, flow charts, and/or data sheets), or other products to determine conformance to requirements.

4.4.2 Analysis (A)

Analysis consists of a theoretical treatment performed using generally recognized and accepted mathematical techniques (which may include simulation or computer analysis using appropriate models) to determine conformance to requirements.

4.4.3 Demonstration (D)

Demonstration consists of the exercise of hardware, software, or operations in a specified environment such that pre-designed inputs produce known, predictable, and repeatable outputs that can be readily observed and qualitatively evaluated to determine conformance to requirements.

4.4.4 Test (T)

Test consists of the exercise of the hardware, software, or operations in a specified environment such that pre-designed inputs produce measurable and repeatable outputs and/or data that are instrumented, recorded, audited, compared, and/or

analyzed to determine conformance to requirements.

4.4.5 Verification Level

Verification that the equipment performs in accordance with the specifications will be performed in the system (S), unit (U), or component (C) level as indicated in test verification *Table 4.4*.

EQUIPMENT SPECIFICATION FOR DEICE CONTROLLER UNIT
4-09-6500-0000

Table 4.4 Test Verification Matrix

Spec	Title/Requirement	Method	Level	Comments
1.0	Scope	--	--	Information
1.1	Introduction	--	--	Information
2.0	Applicable Documents	--	--	Information
3.0	Requirements	--	--	Information
3.1	Item Definition	--	--	Information
3.1.1	Unit Summary	--	--	Information
3.2	Electrical and Mechanical	--	--	Information
3.2.1	Electrical Interfaces	--	--	
	480 VAC Power, 4 Wires	I	U	Labels
	120 VAC Power, 2 Wires	I	U	Labels
	Ground Input, 1 Wire	I	U	Labels
	264 Heaters, 792 Wires	I	U	Labels
	60 RTD Sensors, 180 Wires	I	U	Labels
	1 Network Connection	I	U	
3.2.2	Unit Location	--	--	Information
3.2.3	Physical Characteristics	--	--	
	Metal Enclosure	I	U	
3.2.3.1	Size and Weight	--	--	
	Maximum Size	I	U	
	Maximum Weight	I	U	
3.2.3.2	Mounting Configuration	I	U	
3.2.3.3	Enclosure Cooling	D	U	
3.3	Electrical Design	--	--	Title
3.3.1	Power Control, Quad-1	--	--	
a)	Power Module	T	U or C	On/Off, Zero-Crossing Switch
b)	Power Command	D	U	Remote
c)	Fuses, 66	I	U	
d)	Terminal Connections, 198	I	U	
3.3.2	Power Control, Quad-2	--	--	
a)	Power Module	T	U or C	On/Off, Zero-Crossing Switch
b)	Power Command	D	U	Remote
c)	Fuses, 66	I	U	
d)	Terminal Connections, 198	I	U	
3.3.3	Power Control, Quad-3	--	--	
a)	Power Module	T	U or C	On/Off, Zero-Crossing Switch
b)	Power Command	D	U	Remote
c)	Fuses, 66	I	U	
d)	Terminal Connections, 198	I	U	
3.3.4	Power Control, Quad-4	--	--	
a)	Power Module	T	U or C	On/Off, Zero-Crossing Switch
b)	Power Command	D	U	Remote
c)	Fuses, 66	I	U	
d)	Terminal Connections, 198	I	U	
3.3.5	Input Power Circuit Protection	--	--	Title
3.3.5.1	480 VAC Switch and Protection	--	--	
	Emergency Off Switch	D	U	Disconnect Switch
	Circuit Protection	I	U	
3.3.5.2	120 VAC Circuit Protection	I	U	

EQUIPMENT SPECIFICATION FOR DEICE CONTROLLER UNIT
4-09-6500-0000

Spec	Title/Requirement	Method	Level	Comments
3.3.6	Remote Monitor and Control	D	U	Ethernet Communications
3.3.6.1	Power Module Control	D	U	Power Module Control, On/Off
3.3.6.2	Current Monitor	D	U	Monitor Current with Load
3.3.6.3	Temperature Monitor	D	U	Monitor 48 RTD Sensors
3.3.8	Local Monitor and Control	--	--	Information
3.3.8.1	Power ON/OFF Switch	D	U	
3.3.8.2	Emergency OFF Switch	D	U	
3.3.8.4	Heating Indicator	D	U	
3.4	Environmental Conditions	--	--	
a)	Operating Temperature	I	U	0 to +45C
b)	Non-Operating Temperature	I	U	-20 to +60C
c)	Operating Humidity	I	U	5 to 75%
d)	Non-Operating Humidity	I	U	5 to 90%
e)	Operating Altitude	I	U	3200m
f)	Non-Operating Altitude	I	U	9000m (contractor to provide waiver)
3.5	Design and Construction	--	--	Title
3.5.1	Identification and Marking	--	--	
a)	Unit Name	I	U	
b)	Part Number	I	U	
c)	Manufacturer Name	I	U	
3.5.2	Maintainability	I	U	
3.5.3	Safety	--	--	
3.5.3.1	Unit Enclosure Door Interlock	D	U	
3.5.3.2	Ground Fault Monitor	D	U	
3.5.3.3	Smoke Ventilation	I	U	
3.5.3.4	NEC Compliance	I	U	
3.5.4	EMI and EMC	I	U	
3.6	Engineering Drawings	--	--	
a)	Electrical Schematics	I	U	
b)	Mechanical Drawings	I	U	
c)	Bill of Materials	I	U	
d)	Operation Manual	I	U	