

System One
Heated Humidifier

USER MANUAL

RESPIRONICS

Table of Contents

Intended Use.....	2
Warnings.....	2
Cautions.....	2
Symbol Key.....	2
System Features and Contents.....	3
Connecting the Therapy Device.....	4
Disconnecting the Therapy Device.....	5
Daily Use.....	5
Home Cleaning: Water Tank.....	9
Home Cleaning: Humidifier Base.....	9
Hospital and Institution Cleaning.....	10
Service.....	10
Traveling with the System.....	10
Troubleshooting.....	11
Specifications.....	13
Disposal.....	14
How to Contact Respiroics.....	14
EMC Information.....	15
Limited Warranty.....	Back Page

CAUTION: U. S. federal law restricts this device to sale by or on the order of a physician.

Intended Use

The Heated Humidifier is an accessory for the Respiration REMstar and BiPAP therapy devices to provide moisture to the patient circuit. It is intended for use in spontaneously breathing patients weighing over 30 kg (66 lbs), in the home or hospital/institutional environment, who use mask-applied positive pressure ventilation therapy.

Warnings

A warning indicates the possibility for injury to the user or the operator.

- Use the humidifier only for its intended use as described in this manual. Use only accessories recommended by Respiration.
- Periodically inspect the humidifier for signs of wear or damage. Never operate the humidifier if any parts are damaged, if it is not working properly, or if the humidifier has been dropped or mishandled. Do not use the humidifier if the water tank is leaking or damaged in any way. Have any damaged parts replaced before continuing use.
- Periodically inspect the humidifier power cord for signs of wear or damage. If it becomes worn or damaged, contact Respiration or your home care provider for a replacement.
- Allow the humidifier heater plate and water to cool down for approximately 15 minutes before removing the water tank. A burn may result from: touching the heater plate, coming in contact with the heated water, or touching the tank pan.
- This equipment is not suitable for use in the presence of a flammable anesthetic mixture with air or with oxygen or nitrous oxide.
- When installing the water tank, do not allow any water to spill into the humidifier or therapy device.
- If you notice any unexplained changes in the performance of this device, if it is making unusual or harsh sounds, if it has been dropped or mishandled, if water is spilled into the enclosure, or if the enclosure is broken, disconnect the power cord from the therapy device and discontinue use. Contact your home care provider.
- Before cleaning the humidifier, always remove from the therapy device.
- Empty and clean the water tank daily to prevent mold and bacteria growth. Wipe the seal completely.

Note: Please see the “Limited Warranty” section of this manual for information on warranty coverage.



Cautions

A caution indicates the possibility of damage to the device.

- Do not place the humidifier directly onto carpet, fabric, or other flammable materials.
- Do not place the device in or on any container that can collect or hold water. Take precautions to protect furniture from water damage.
- Do not fill the water tank above the maximum fill line. Damage to the humidifier or therapy device may occur. If the water tank is overfilled, water may leak out of the tank inlet (located on the back of the tank) when installing the tank lid.
- Use only room temperature distilled water in the tank. Do not put any chemicals or additives into the water. Possible airway irritation or damage to the water tank may result.
- Remove the tank, empty all water, and replace the empty tank before transporting the humidifier base.
- Do not attempt to fill the water tank while it is still inside the humidifier.
- To avoid spilling, do not disconnect the humidifier from the therapy device with water in the tank. Remove the water tank from the humidifier before disconnecting the therapy device.
- Do not turn the humidifier on without the water tank installed. The Humidifier number setting must remain on 0 if there is no water in the water tank.
- The humidifier door must be set in the open position before removing the water tank. Do not remove the water tank without making sure that the humidifier door locks into the open position.
- Do not move the humidifier while the water tank has water in it.
- Only the hospital and institution cleaning procedures listed in this manual are recommended by Respiration. Use of other cleaning and disinfecting processes, not specified by Respiration, may affect the performance of the product.

Symbol Key

The following symbols appear on the device:

SYMBOL	DEFINITION	SYMBOL	DEFINITION
	Maximum Fill Line		Follow Instructions for Use
	Hot Water, Hot Surface	IPX1	Drip Proof Equipment

System Features and Contents

IMPORTANT: Read and understand the entire manual for your therapy device before attempting to use this humidifier.

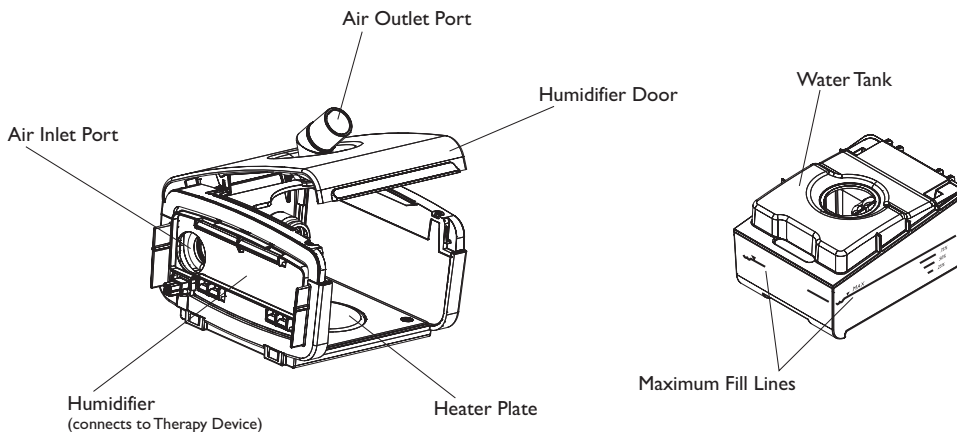

This figure illustrates many of the device features and contents, described in the table below.

ITEM	DESCRIPTION
Humidifier	Connect your therapy device here.
Air Inlet Port	Connects to the outlet port on the therapy device.
Air Outlet Port (conical, 22 mm)	Connect the patient circuit here.
Heater Plate	Warms the water in the water tank.
Humidifier Door	Open the door to access the water tank.
Humidifier Door Lever	Lift up on the lever to open the humidifier door.
Water Tank	The removable water tank holds the water for humidification.
Maximum Fill Lines	The fill lines indicates the maximum water level for safe operation. (Found on front and both sides of tank)

Note: Read all instructions before using the humidifier.

Note: This humidifier is specified for use with Respiration REMstar and BiPAP therapy devices only.

Connecting the Therapy Device

1. When using a humidifier, the patient circuit attaches to the air outlet port on the humidifier.
2. To connect the therapy device to the humidifier, first you must remove the side cover on the therapy device. Press in the tab on the side cover and pull the cover away from the unit.

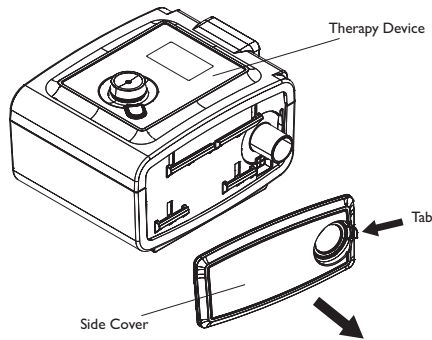

3. Next, line up the components side by side. Make sure that the guides on the humidifier fit into the slots on the therapy device and the air outlet port on the therapy device fits into the air inlet port on the humidifier.

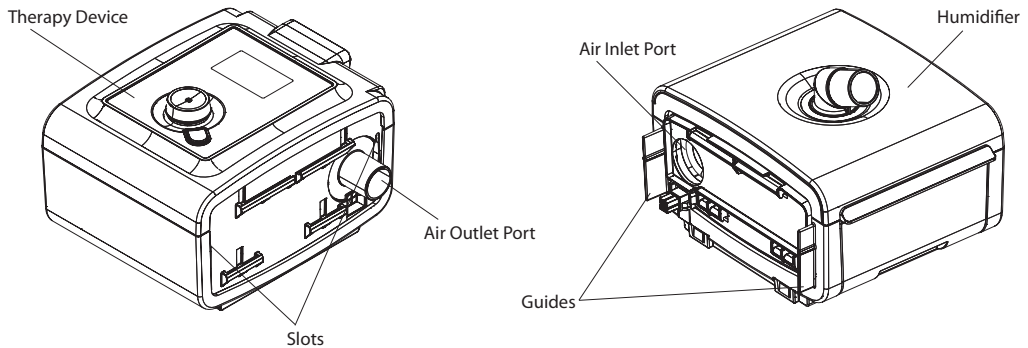

4. Simply press the two units together until they snap into place. Make sure that the therapy device and the humidifier are completely seated against each other.

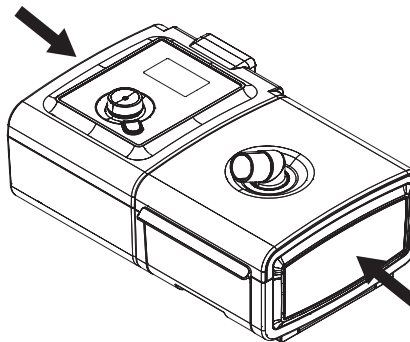

Disconnecting the Therapy Device

CAUTION: To avoid spilling, do not disconnect the humidifier from the therapy device with water in the tank. Remove the water tank from the humidifier before disconnecting the therapy device.

1. Grasp the release latch on the bottom of the humidifier.
2. While holding both the therapy device and the humidifier, pull the release latch and pull the two units apart.

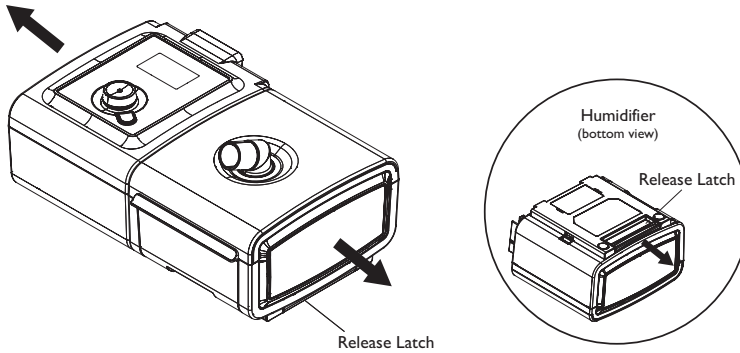

3. If you will be using the therapy device without the humidifier, reattach the side cover to the therapy device.

Daily Use

1. Place the connected therapy device with humidifier on a firm, flat surface lower than your sleeping position.

CAUTION: Do not place the humidifier directly onto carpet, fabric, or other flammable materials.

CAUTION: Do not place the device in or on any container that can collect or hold water. Take precautions to protect furniture from water damage.

CAUTION: Do not turn the humidifier on without the water tank installed. The Humidifier number setting must remain on 0 if there is no water in the water tank.

CAUTION: Do not attempt to fill the tank while it is still inside the humidifier.

WARNING: Allow the humidifier heater plate and water to cool down for approximately 15 minutes before removing the water tank. A burn may result from: touching the heater plate, coming in contact with the heated water, or touching the tank pan.

2. Lift up on the release lever to open the humidifier door until it locks in an open position. You will hear a “click” once the door is opened far enough to remain in an open position. Remove the water tank by grasping the front of the tank and sliding it out of the humidifier base.

CAUTION: The humidifier door must be set in the open position before removing the water tank. Do not remove the water tank without making sure that the humidifier door locks into the open position.

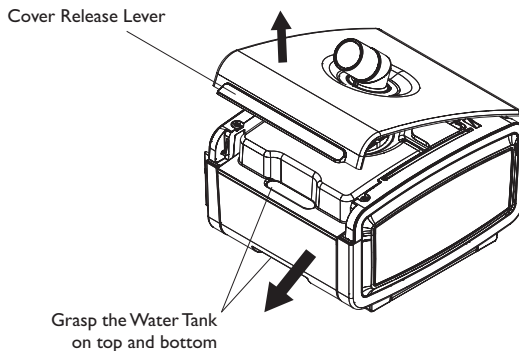

3. Press the tab in the hole on top of the tank in toward the front of the tank. Gently remove the tank lid from the tank base and set aside. Empty any remaining water from the base of the tank.

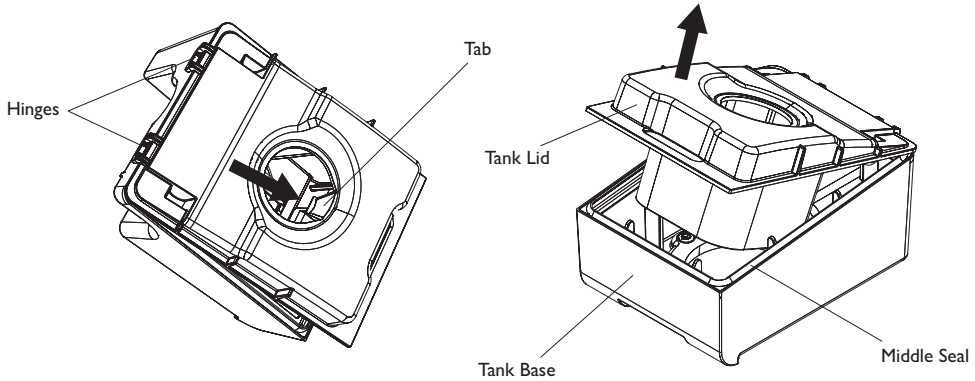

4. Rinse the tank with water. With the water tank sitting on a flat surface, fill it with distilled water (approximately 325 ml) no higher than the maximum fill line located on the front and both sides of the tank.

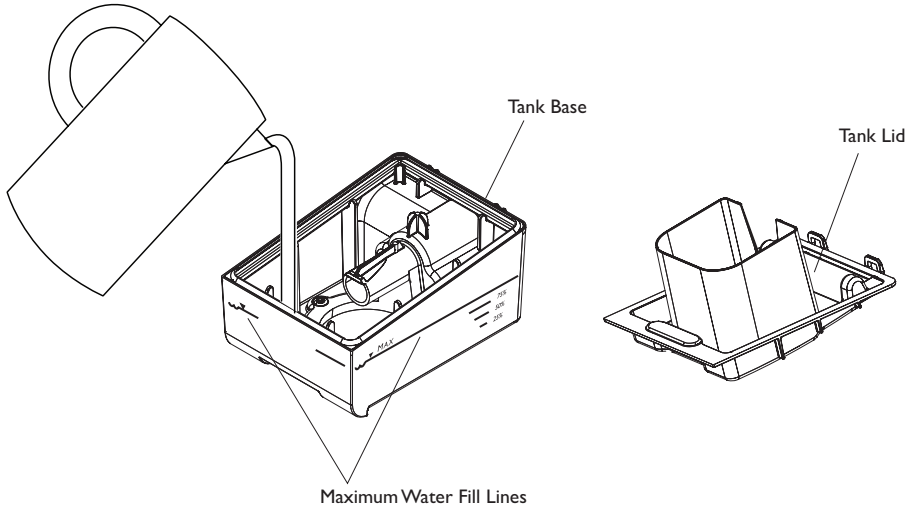

CAUTION: Use only room temperature distilled water in the tank. Do not put any chemicals or additives into the water. Possible airway irritation or damage to the water tank may result.

CAUTION: Do not fill the water tank above the maximum fill line. Damage to the humidifier or therapy device may occur. If the water tank is overfilled, water may leak out of the tank inlet (located on the back of the tank) when installing the tank lid.

5. Reassemble the tank by placing the hinges on the tank lid over the 2 tabs on the back of the tank base. Close the lid until the tab on the lid snaps back under the lip in the tank base. Inspect the tank. When it is closed correctly, the lid should be seated completely on the middle seal and it should sit snugly on the tank base so the tab can easily snap back in place.

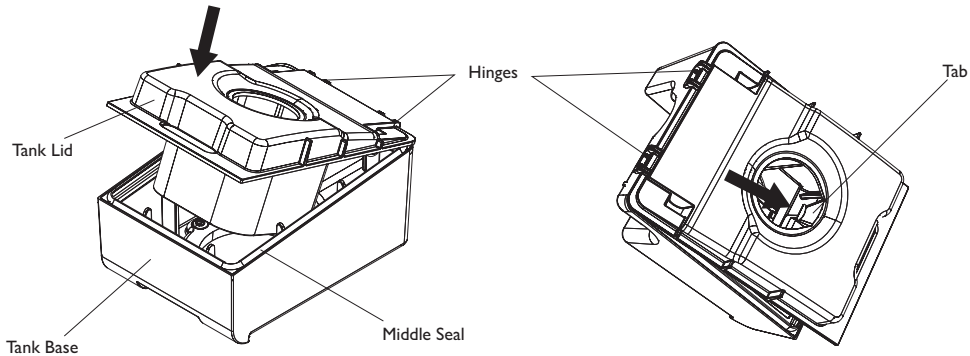

Note: If the lid does not close easily onto the base, separate the two parts, reassemble the tank, and inspect it again.
CAUTION: Do not fill the water tank above the maximum fill line. Damage to the humidifier or therapy device may occur. If the water tank is overfilled, water may leak out of the tank inlet (located on the back of the tank) when installing the tank lid.

6. Slide the water tank back into the humidifier.
WARNING: When installing the tank, do not allow any water to spill into the humidifier or therapy device.
CAUTION: Do not move the humidifier while the water tank has water in it.
7. Plug the power supply cord into the back of the therapy device.
8. Plug the AC power cord into the power supply provided with your therapy device, and then plug the AC power cord into an electrical outlet that is not controlled by a wall switch.
9. Attach the flexible tubing from the patient circuit to the humidifier's air outlet port.
IMPORTANT: Before each use, examine the flexible tubing for any kinks, damage, or debris. If necessary, clean the tubing to remove the debris. Replace any damaged tubing.
10. The Home screen (shown below) will appear on the therapy device.

Therapy	Flex
Info	Setup

Home Screen

Note: "Flex" shown above will display as the current Flex setting chosen by the provider.

11. Put on your mask assembly when the air starts to flow.
12. Turn the Wheel to toggle between the four options. Highlight "Therapy". Press the Wheel to turn on the airflow and begin therapy. The Therapy screen will appear which will show the current pressure setting being delivered.
Note: For more information on your therapy device settings, refer to the manual included with your therapy device.

13. The Humidifier icon and current Humidifier number setting will light up on the device.

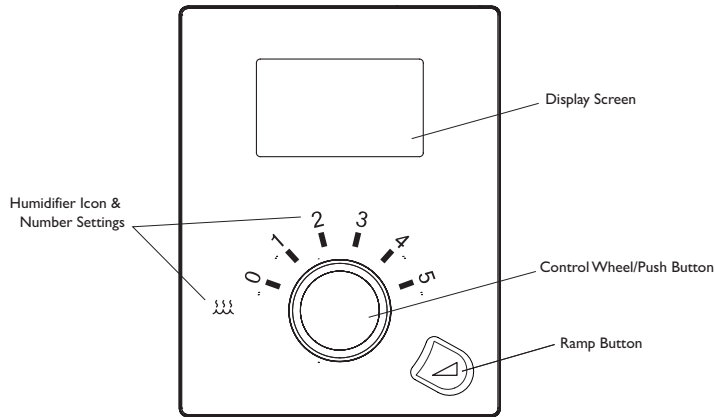

Note: If you are having trouble with your mask, refer to the instructions included with the mask.

14. Turn the wheel to adjust the Humidifier number to the desired heater plate setting. The settings are 0 (which turns the heater plate off), 1, 2, 3, 4, and 5. The delivered Relative Humidity (RH) shall increase as the setting increases.

CAUTION: Do not turn the humidifier on without the water tank installed. The Humidifier number setting must remain on 0 if there is no water in the water tank.

IMPORTANT: The Humidifier LED will remain on but will dim when the Humidifier is attached. The number may turn off depending on the LED Backlight settings.

IMPORTANT: The ideal humidity setting depends on room temperature and humidity. Initially a setting of 2 is recommended. You can adjust this setting at any time. Turn the Wheel to change the setting.

Note: You can also adjust the humidifier setting while therapy is off in the setup screen from the main menu.

15. Press the Wheel again to turn off therapy and return to the home screen.

Home Cleaning: Water Tank

WARNING: Before cleaning the humidifier, always remove from the therapy device.

1. Turn the humidifier setting to 0, turn the therapy device off, and allow the heater plate and water to cool.

WARNING: Allow the humidifier heater plate and water to cool down for approximately 15 minutes before removing the water tank. A burn may result from: touching the heater plate, coming in contact with the heated water, or touching the tank pan.

2. Open the humidifier door with the release lever, and then slide the water tank out of the humidifier base.
3. Press the tab in the hole on top of the tank in toward the front of the tank. Gently remove the tank lid from the tank base. Empty any remaining water from the base of the tank.
4. Wash the parts of the tank in a solution of warm water and a mild liquid dish detergent. Gently wash the middle seal. Rinse the parts with clean water. Wipe the parts completely on the top and bottom. Allow them to air dry.

WARNING: Empty and clean the water tank daily to prevent mold and bacteria growth. Wipe the seal completely.

5. Inspect the tank and seal for damage.

Note: Never use the water tank if the tank lid does not fit comfortably on the tank base.

6. Before using the tank, fill it with distilled water (per the directions in the Daily Use section) no higher than the maximum fill line located on the front and sides of the tank.
7. Reassemble the tank by placing the hinges on the tank lid over the 2 tabs on the back of the tank base. Close the lid until the tab on the lid snaps back under the lip in the tank base. Inspect the tank. When it is closed correctly, the lid should be seated completely on the middle seal and it should sit snugly on the tank base so the tab can easily snap back in place. Inspect the water tank for any leaks or damage. If the water tank shows signs of wear or damage, contact your home care provider for a replacement.

Note: If the lid does not close easily onto the base, separate the two parts, reassemble the tank, and inspect it again.

Home Cleaning: Humidifier Base

1. Clean the humidifier base and heater plate by wiping it with a damp cloth. Allow the platform to air dry before reconnecting to the therapy device.
2. Inspect the humidifier base for any damage and replace it if necessary.
3. Clean the humidifier outlet port by using a damp bottle brush or a damp cloth. Insert the brush or cloth approximately 7 cm (2.75 inches) into the outlet opening while cleaning.

Hospital and Institution Cleaning

CAUTION: Only the hospital and institution cleaning procedures listed in this manual are recommended by Respiroics. Use of other cleaning and disinfecting processes, not specified by Respiroics, may affect the performance of the product.

Cleaning Prior to Disinfection

Clean the humidifier base and outlet as described in the previous Home Cleaning section.

Clean and disinfect the humidifier's water tank using the procedures below.

1. Disassemble the tank by separating the tank lid and tank base.
2. While soaking the tank pieces in mild liquid dish detergent, use a soft bristle brush to clean each piece. Pay close attention to all corners and crevices.
3. Rinse each piece with water twice. Be sure to agitate it vigorously in water when rinsing and allow to air dry, but not in direct sunlight.

Disinfection

The following processes can be used to disinfect the water tank for a maximum of 60 cycles:

- Thermal Disinfection: Immersion in a (tap) water bath at $75^{\circ}\text{C} \pm 2^{\circ}\text{C}$ for 30 minutes
- Control III
- Cidex
- Cidex OPA

Following disinfection, visually inspect each piece. Discard and replace any damaged parts.

Service

The humidifier does not require routine servicing. If any part of the humidifier is worn or damaged, contact Respiroics or your home care provider. See the Troubleshooting section later in the manual for additional information.

Traveling with the System

Packing the System

1. Remove the water tank and empty all water.
2. Put the empty water tank back into the device.
3. Pack your humidifier in your carry-on luggage.

CAUTION: Do not move the humidifier while the water tank has water in it.

When you are traveling, the optional carrying case for your therapy device can be used for carry-on luggage only. The carrying case will not protect the humidifier if it is put through checked baggage.

For your convenience at airport security stations, there is a note on the bottom of the humidifier stating that it is medical equipment. It may be helpful to bring this manual along with you to help security personnel understand the device.

If you are traveling to a country with a line voltage different than the one you are currently using with the therapy device, a different power cord or an international plug adapter may be required to make your power cord compatible with those where you visit. Contact your home care provider for additional information.

Troubleshooting

The table below lists some of the problems you may experience with your humidifier and possible solutions.

PROBLEM	WHY IT HAPPENED	WHAT TO DO
Nothing happens when you apply power to the humidifier.	Loss of AC/DC power or the device is unplugged.	Verify that the humidifier and therapy device are properly plugged in. Make sure the AC power cord is connected correctly to the power supply and the power supply cord is correctly plugged into the wall. If the problem continues to occur, contact your home care provider. Return the humidifier, therapy device, and power supply to your provider to determine if the problem is with the therapy device, humidifier, or power supply.
High Leak	The tubing is not connected correctly and doesn't seal properly.	Remove your mask and tubing and check for kinks or tears. If it is torn or damaged, contact your home care provider or Respironics for replacement tubing and/or mask. If the tubing is not damaged, reattach your tubing, turn on the airflow, and check to make sure you do not still feel air coming out of the port area.
	The therapy device is not seated correctly against the humidifier.	Remove the therapy device from the humidifier and reconnect. Make sure the air inlet port on the humidifier connects securely to the air outlet port on the device. If high leak persists, issue may be caused by a misaligned or damaged seal. Seals are not user-serviceable components. Please contact your home care provider or Respironics.
	The humidifier tank is not properly seated in the humidifier.	Remove the water tank from the humidifier base, and then slide the tank back in the humidifier, making sure it is pushed back as far as it can go. If high leak persists, issue may be caused by a misaligned or damaged seal. Seals are not user-serviceable components. Please contact your home care provider or Respironics.
The humidifier LED icon on the therapy device is flashing.	There is no communication between the therapy device and the humidifier.	Following the Daily Use section earlier in this manual, check the outlet power and verify that the humidifier and therapy device are properly plugged in. Make sure the AC power cord is connected correctly to the therapy device's power supply. Make sure the AC power cord is correctly plugged into the wall. If the problem continues to occur, contact your home care provider. Return the humidifier, therapy device, and power supply to your provider, to determine if the problem is with the therapy device, humidifier, or power supply.
	The therapy device is not seated properly against the humidifier.	Remove the therapy device from the humidifier and reconnect it. Make sure the air inlet port on the side of the humidifier connects securely to the air outlet port on the side of the device.
	The heater plate is not heating.	Check the power connections to the humidifier. If the problem continues, contact your home care provider or Respironics. Note: If the water is not heating, you can temporarily use the humidifier as an unheated pass-over humidifier.
The humidifier is cracked or damaged.	The humidifier was dropped or mishandled.	If the humidifier does not operate properly after being dropped or mishandled, contact your home care provider or Respironics.

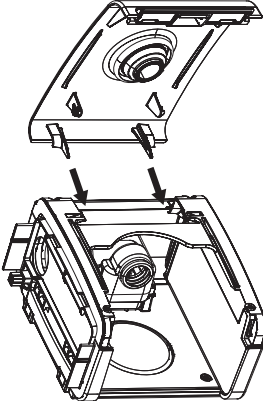
PROBLEM	WHY IT HAPPENED	WHAT TO DO
The therapy device is operating but the humidifier's airflow is low or stopped.	The humidifier has an airflow obstruction.	Contact your home care provider. Return the humidifier and power supply to your provider to determine the problem.
The water tank's middle seal is damaged.	The seal may become damaged during use.	Check the seal for any tears or other damage. If it is damaged, contact your home care provider.
Excessive condensation in the tubing.	The heater plate temperature setting is too high.	Reduce the heater control setting.
	The humidifier is positioned incorrectly.	Verify that the humidifier and therapy device are away from air conditioning equipment.
The humidifier door has been accidentally removed from the humidifier.	Humidifier door was lifted past the locked open position.	<p>The humidifier door can be easily reattached.</p> <p>With the water tank removed, align the hinge side of the door with the back of the humidifier in a fully open position (see figure below). Make sure the hinges are aligned with the grooves of the humidifier. Rotate the door closed. You will need to apply pressure until the door snaps past the locked open position. Verify that the door is working properly.</p>  <p>If further assistance is needed, contact your home care provider.</p>
The humidifier has fallen off your table or night stand.	The humidifier may not have been properly seated on the night stand, or the placement of the tubing may have caused the device to fall.	<p>Always make sure your humidifier is placed on a hard, flat surface so the rubber feet on the bottom of the humidifier base can adhere to the surface (make sure there is no fabric under the base). The humidifier must be level for proper operation.</p> <p>Also, place the humidifier away from the edge of the night stand or table, so it doesn't accidentally get knocked off the table.</p> <p>If the humidifier falls and water gets into the therapy device, drain all water out of the therapy device. Allow it to air dry to make sure it is completely dry before reapplying power.</p> <p>If the placement of the tubing causes the humidifier to fall, make sure that you use proper hose management when setting up your device. Route the tubing behind the bed's headboard.</p> <p>If the humidifier does not operate correctly after falling, contact your home care provider or Respironics.</p>

Note: For information on troubleshooting your therapy device, see the manual included with your therapy device.

Specifications

Environmental

Operating Temperature: 5° to 35° C (41° to 95° F)
Storage Temperature: -20° to 60° C (-4° F to 140° F)
Relative Humidity (operating & storage): 15 to 95% (non-condensing)
Atmospheric Pressure: 77 to 101 kPa (0 - 2286 m / 0 - 7500 ft)

Physical

Dimensions: 18 x 14 x 10 cm (7" L x 5.5" W x 4" H)
Weight: Approximately 0.89 kg (1.95 lbs.)

Water Capacity

325 ml (11 oz.) at recommended water level

Standards Compliance

This device is designed to conform to the following standards:

IEC 60601-1 General Requirements for Safety of Medical Electrical Equipment
EN ISO 8185:2007 General Requirements for Humidification Systems

Electrical

(When the heated humidifier is used with a Respironics therapy device)

AC Power Consumption: 100 – 240 VAC, 50/60 Hz, 2.1 A
DC Power Consumption: 12 VDC, 5.0 A
Type of Protection Against Electric Shock: Class II Equipment
Degree of Protection Against Electric Shock: Type BF Applied Part
Degree of Protection against Ingress of Water: Drip Proof, IPX1
Mode of Operation: Continuous
Electromagnetic Compatibility: The device meets the requirements of EN 60601-1-2, 2nd edition.

Heater Plate

Max Temperature: 70° C (158° F)

Pressure Drop with Humidifier

Max.: 0.3 cm H₂O at 60 LPM flow

Humidity

Humidity_{min} Output: 10 mg H₂O/L
Measured @ max flow, 35° C, 15% RH.

Disposal

Dispose of this device in accordance with local regulations.

How to Contact Respironics

To have your device serviced, contact your home care provider. If you need to contact Respironics directly, call the Customer Service department at 1-800-345-6443 or 1-724-387-4000.

You can also use the following address:

Respironics, Inc.
1001 Murry Ridge Lane
Murrysville, PA 15668

EMC Information

Because this heated humidifier cannot operate without using a Respironics therapy device, refer to the device's User Manual for additional EMC information.

GUIDANCE AND MANUFACTURER'S DECLARATION - ELECTROMAGNETIC EMISSIONS: This device is intended for use in the electromagnetic environment specified below. The user of this device should make sure it is used in such an environment.

EMISSIONS TEST	COMPLIANCE	ELECTROMAGNETIC ENVIRONMENT - GUIDANCE
RF emissions CISPR 11	Group 1	The device uses RF energy only for its internal function. Therefore, its RF emissions are very low and are not likely to cause any interference in nearby electronic equipment.
RF emissions CISPR 11	Class B	The device is suitable for use in all establishments, including domestic establishments and those directly connected to the public low-voltage power supply network.
Harmonic emissions IEC 61000-3-2	Class A	
Voltage fluctuations/Flicker emissions IEC 61000-3-3	Complies	

GUIDANCE AND MANUFACTURER'S DECLARATION - ELECTROMAGNETIC IMMUNITY: This device is intended for use in the electromagnetic environment specified below. The user of this device should make sure it is used in such an environment.

IMMUNITY TEST	IEC 60601 TEST LEVEL	COMPLIANCE LEVEL	ELECTROMAGNETIC ENVIRONMENT - GUIDANCE
Electrostatic Discharge (ESD) IEC 61000-4-2	±6 kV contact ±8 kV air	±6 kV contact ±8 kV air	Floors should be wood, concrete or ceramic tile. If floors are covered with synthetic material, the relative humidity should be at least 30%.
Electrical Fast Transient/Burst IEC 61000-4-4	±2 kV for power supply lines ±1 kV for input-output lines	±2 kV for supply mains ±1 kV for input/output lines	Mains power quality should be that of a typical home or hospital environment.
Surge IEC 61000-4-5	±1 kV Line to Line ±2 kV Line(s) to Ground	±1 kV differential mode ±2 kV for common mode	Mains power quality should be that of a typical home or hospital environment.
Voltage dips, short interruptions and voltage variations on power supply input lines IEC 61000-4-11	<5% U_T (>95% dip in U_T) for 0.5 cycle 40% U_T (60% dip in U_T) for 5 cycles 70% U_T (30% dip in U_T) for 25 cycles <5% U_T (>95% dip in U_T) for 5 sec	<5% U_T (>95% dip in U_T) for 0.5 cycle 40% U_T (60% dip in U_T) for 5 cycles 70% U_T (30% dip in U_T) for 25 cycles <5% U_T (>95% dip in U_T) for 5 sec	Mains power quality should be that of a typical home or hospital environment. If the user of the device requires continued operation during power mains interruptions, it is recommended that the device be powered from an uninterruptible power supply or a battery.
Power frequency (50/60 Hz) magnetic field IEC 61000-4-8	3 A/m	3 A/m	Power frequency magnetic fields should be at levels characteristic of a typical location in a typical hospital or home environment.
NOTE: U_T is the a.c. mains voltage prior to application of the test level.			

GUIDANCE AND MANUFACTURER'S DECLARATION - ELECTROMAGNETIC IMMUNITY: This device is intended for use in the electromagnetic environment specified below. The user of this device should make sure it is used in such an environment.

IMMUNITY TEST	IEC 60601 TEST LEVEL	COMPLIANCE LEVEL	ELECTROMAGNETIC ENVIRONMENT - GUIDANCE
Conducted RF IEC 61000-4-6	3 Vrms 150 kHz to 80 MHz	3 Vrms	Portable and mobile RF communications equipment should be used no closer to any part of the device, including cables, than the recommended separation distance calculated from the equation applicable to the frequency of the transmitter. Recommended separation distance: $d = 1.2 \sqrt{P}$ 150 kHz to 80 MHz
Radiated RF IEC 61000-4-3	3 V/m 80 MHz to 2.5 GHz	3 V/m	$d = 1.2 \sqrt{P}$ 80 MHz to 800 MHz $d = 2.3 \sqrt{P}$ 800 MHz to 2.5 GHz Where P is the maximum output power rating of the transmitter in watts (W) according to the transmitter manufacturer and d is the recommended separation distance in meters (m). Field strengths from fixed RF transmitters, as determined by an electromagnetic site survey a, should be less than the compliance level in each frequency range b. Interference may occur in the vicinity of equipment marked with the following symbol: 

NOTE 1: At 80 MHz and 800 MHz, the higher frequency range applies.
 NOTE 2: These guidelines may not apply in all situations. Electromagnetic propagation is affected by absorption and reflection from structures, objects, and people.
 a: Field strengths from fixed transmitters, such as base stations for radio (cellular/cordless) telephones and land mobile radios, amateur radio, AM and FM radio broadcast and TV broadcast cannot be predicted theoretically with accuracy. To assess the electromagnetic environment due to fixed RF transmitters, an electromagnetic site survey should be considered. If the measured field strength in the location in which the device is used exceeds the applicable RF compliance level above, the device should be observed to verify normal operation. If abnormal performance is observed, additional measures may be necessary, such as re-orienting or relocating the device.
 b: Over the frequency range 150 kHz to 80 MHz, the field strengths should be less than 3 V/m.

Recommended Separation Distances between Portable and Mobile RF Communications Equipment and This Device: The device is intended for use in an electromagnetic environment in which radiated RF disturbances are controlled. The customer or the user of this device can help prevent electromagnetic interference by maintaining a minimum distance between portable and mobile RF communications equipment (transmitters) and this device as recommended below, according to the maximum output power of the communications equipment.

RATED MAXIMUM POWER OUTPUT OF TRANSMITTER (W)	SEPARATION DISTANCE ACCORDING TO FREQUENCY OF TRANSMITTER (m)		
	150 kHz to 80 MHz $d = 1.2 \sqrt{P}$	80 MHz to 800 MHz $d = 1.2 \sqrt{P}$	800 MHz to 2.5 GHz $d = 2.3 \sqrt{P}$
0.01	0.12	0.12	0.23
0.1	0.38	0.38	0.73
1	1.2	1.2	2.3
10	3.8	3.8	7.3
100	12	12	23

For transmitters rated at a maximum output power not listed above, the recommended separation distance d in meters (m) can be estimated using the equation applicable to the frequency of the transmitter, where P is the maximum output power rating of the transmitter in watts (W) according to the transmitter manufacturer.
 Note 1: At 80 MHz and 800 MHz, the separation distance for the higher frequency range applies.
 Note 2: These guidelines may not apply in all situations. Electromagnetic propagation is affected by absorption and reflection from structures, objects, and people.

Limited Warranty

Respironics, Inc. warrants that the system shall be free from defects of workmanship and materials and will perform in accordance with the product specifications for a period of two (2) years from the date of sale by Respironics, Inc. to the dealer. If the product fails to perform in accordance with the product specifications, Respironics, Inc. will repair or replace – at its option – the defective material or part. Respironics, Inc. will pay customary freight charges from Respironics, Inc. to the dealer location only. This warranty does not cover damage caused by accident, misuse, abuse, alteration, and other defects not related to material or workmanship. The Respironics, Inc. Service department shall examine any devices returned for service, and Respironics, Inc. reserves the right to charge an evaluation fee for any returned device as to which no problem is found after investigation by Respironics, Inc. Service.

Respironics, Inc. disclaims all liability for economic loss, loss of profits, overhead, or consequential damages which may be claimed to arise from any sale or use of this product. Some states do not allow the exclusion or limitation of incidental or consequential damages, so the above limitation or exclusion may not apply to you.

This warranty is given in lieu of all other express warranties. In addition, any implied warranties – including any warranty of merchantability or fitness for the particular purpose – are limited to two years. Some states do not allow limitations on how long an implied warranty lasts, so the above limitation may not apply to you. This warranty gives you specific legal rights, and you may also have other rights which vary from state to state.

To exercise your rights under this warranty, contact your local authorized Respironics, Inc. dealer or contact Respironics, Inc. at:

1001 Murry Ridge Lane
Murrysville, Pennsylvania 15668-8550
1-724-387-4000

Manufactured for:

Respironics Inc.
1001 Murry Ridge Lane
Murrysville, PA 15668 USA

REF **1058288**

1057395
JR 5/29/2009
EN-DOM