



# Datasheet

## X3G6509B8

## Contents

- Features 1
- Description 1
- Static Parameters 2
- Switching Performance 3
- Thermal Characteristics 3
- Package Dimensions 7
- Gate Driving Examples 9
- Important Notice 11
- Applications 1
- Device Characteristics 2
- Dynamic Parameters 2
- Absolute **Max.** Ratings 3
- Characteristics Diagrams 4
- Testing Conditions 8
- Revision History 10

## Features

$V_{DS}$	$R_{DS(on)}$	$I_{DS}$
700V	82mΩ	20A

- High reliability
- High dv/dt capability
- Extremely low input capacitance
- Zero Qrr
- Outstanding switching performance
- Low system profile
- Dual gate pins

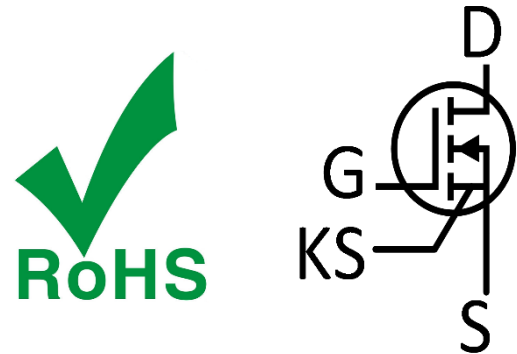
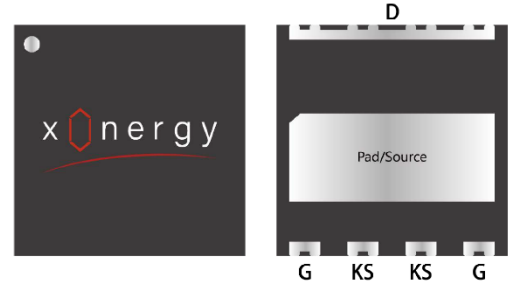

## Applications

- Switching power supplies
- PC and server power supplies
- Adapters, quick chargers
- 5G power supplies

## Description

- The X3G6509B8 is a 700V power GaN HEMT in DFN8\*8 package with dual gate pins. Based on p-GaN enhancement mode (E-mode) GaN-on-silicon technology, it is a normally off and stand-alone device. The device can be switched at very high frequencies in both soft-switching and hard-switching modes while still achieve high efficiency. In addition, our patented dual-gate-pin structure is designed to further improve switching performance and allow flexibility in PCB layout. Advanced packaging methods are implemented to obtain low thermal resistance and high device performance.

Type	Package	Qty
X3G6509B8	DFN8*8	3300

## Device Characteristics

### Static Parameters

Symbol	Parameter	Min.	Typ.	Max.	Unit	Test Conditions
$V_{GS(th)}$	Gate threshold voltage	1.2	1.6	2.3	V	$V_{DS}=V_{GS}$ , $I_D=3.5mA$ , $T_J=25^\circ C$
$BV_{DSS}$	Drain-Source breakdown voltage	700			V	$V_{GS}=0V$ , $I_D=250\mu A$ , $T_J=25^\circ C$
$I_{DSS}$	Drain-Source leakage current,		1	100	$\mu A$	$V_{GS}=0V$ , $V_{DS}=700V$ , $T_J=25^\circ C$
			30		$\mu A$	$V_{GS}=0V$ , $V_{DS}=700V$ , $T_J=150^\circ C$
$I_{GSS}$	Gate-Source leakage current		20	300	$\mu A$	$V_{GS}=6V$ , $V_{DS}=0V$ , $T_J=25^\circ C$
				500	$\mu A$	$V_{GS}=6V$ , $V_{DS}=0V$ , $T_J=125^\circ C$
$R_{DS(on)}$	Static drain-source on resistance		82	107	mΩ	$V_{GS}=6V$ , $I_D=5A$ , $T_J=25^\circ C$
			195		mΩ	$V_{GS}=6V$ , $I_D=5A$ , $T_J=150^\circ C$
$V_{SD}$	Reverse conduction voltage	1.6	1.7	2.1	V	$I_{SD}=1A$ , $V_{GS}=0V$ , $T_J=25^\circ C$
$R_G$	Internal gate resistance		1.4		Ω	$f=5MHz$ , open drain, $T_J=25^\circ C$

### Dynamic Parameters

Symbol	Parameter	Min.	Typ.	Max.	Unit	Test Conditions
$C_{iss}$	Input capacitance		108		pF	$V_{GS}=0V$ , $V_{DS}=400V$ , $f=1MHz$ $T_J=25^\circ C$
$C_{oss}$	Output capacitance		32		pF	
$C_{rss}$	Reverse transfer capacitance		0.9		pF	
$Q_g$	Gate charge		3.9		nC	$V_{DS}=400V$ , $I_D=6A$ , $V_{GS}=6V$ $T_J=25^\circ C$
$Q_{gs}$	Gate to source charge		0.6		nC	
$Q_{gd}$	Gate to drain charge		1.8		nC	
$Q_{rr}$	Reverse recovery charge		0		nC	
$DR_2/DR_1$	Dynamic resistance ratio			1.1	-	$V_{DS}=400V$ , $T_J=25^\circ C$

### Switching Performance

Symbol	Parameter	Min.	Typ.	Max.	Unit	Test Conditions
$t_{d(on)}$	Turn-on delay time		1.4		ns	$V_{DS}=400V, I_D=10A$ $V_{GS}=+6V/0V$ $R_{g(on)}=15\Omega, R_{g(off)}=3\Omega$ $L=70\mu H$ $T_J=25^\circ C$
$t_r$	Rise time		2.2		ns	
$t_{d(off)}$	Turn-off delay time		3.7		ns	
$t_f$	Fall time		5.3		ns	
$E_{on}$	Turn on switching energy		11.2		$\mu J$	
$E_{off}$	Turn off switching energy		5.3		$\mu J$	

### Absolute Max. Ratings

Symbol	Parameter	Value	Unit
$V_{DS-max}$	Breakdown voltage transient @ $T_J=25^\circ C$	850	V
$V_{GS-max}$	Gate to source max. transient voltage @ $T_J=25^\circ C$	-15 to +7	V
$I_{DS-max}$	Gate to source DC current @ $T_C=25^\circ C$	20	A
$I_{DS-max}$	Gate to source DC current @ $T_C=100^\circ C$	13	A
$I_{DS\ pulse-max}$	Pulse drain current(Pulse width 50 $\mu s$ , $V_{GS}=6V$ )	40	A
$dv/dt-max$	Drain to source voltage slew rate	150	V/ns
$T_{J-max}$	Max junction temperature	150	$^\circ C$
$T_{S-max}$	Storage temperature	-55 to 150	$^\circ C$

### Thermal Characteristics (Typical)

Symbol	Parameter	Typ.	Max.	Unit
$R_{thJC}$	Thermal resistance from junction to case	1.2		$^\circ C/W$
$R_{thJA}$	Thermal resistance from junction to ambient		38	
$T_{solder}$	Reflow soldering temperature	260		$^\circ C$

### Characteristics Diagrams

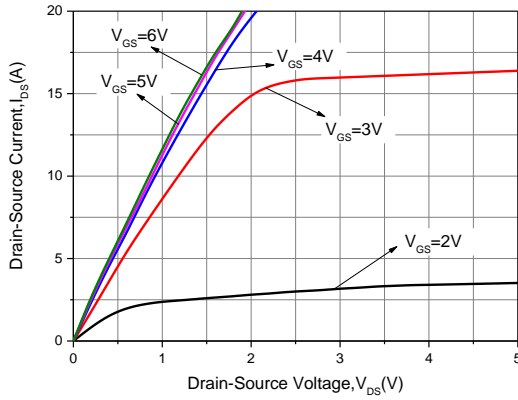

Figure 1. Output Characteristics  $T_j=25^\circ\text{C}$

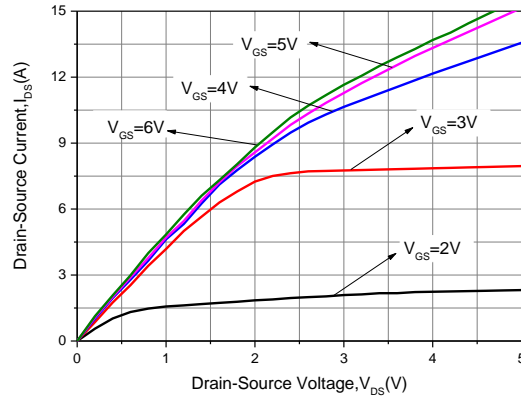

Figure 2. Output Characteristics  $T_j=150^\circ\text{C}$

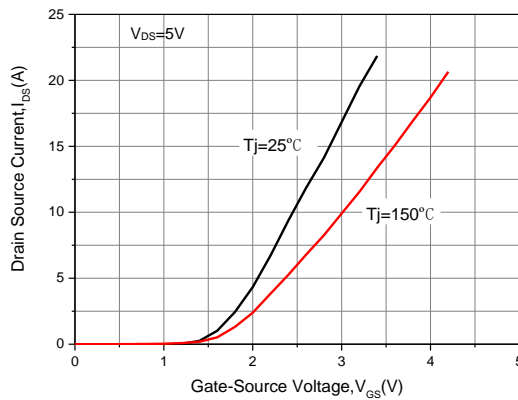

Figure 3. Transfer Characteristic for Various Junction Temperature

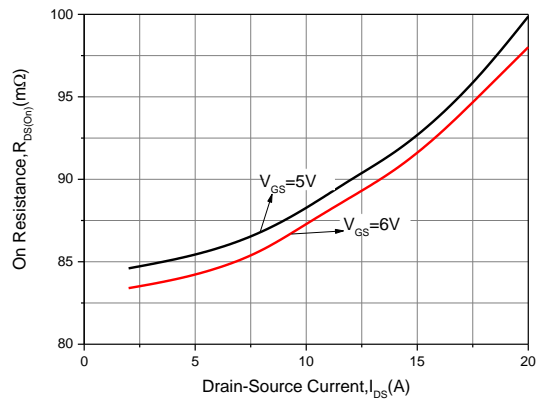

Figure 4. On-resistance vs. Drain Current For Various Gate Voltage @ $25^\circ\text{C}$

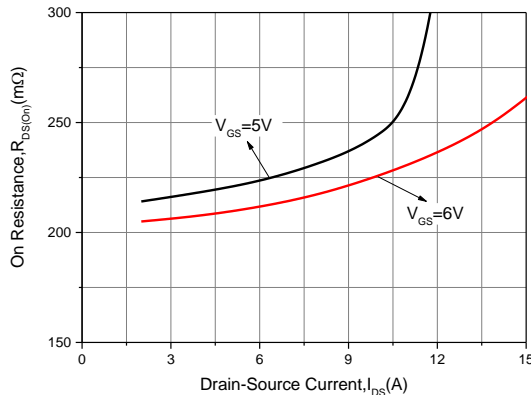

Figure 5. On-resistance vs. Temperature For Various Gate Voltage @ $150^\circ\text{C}$

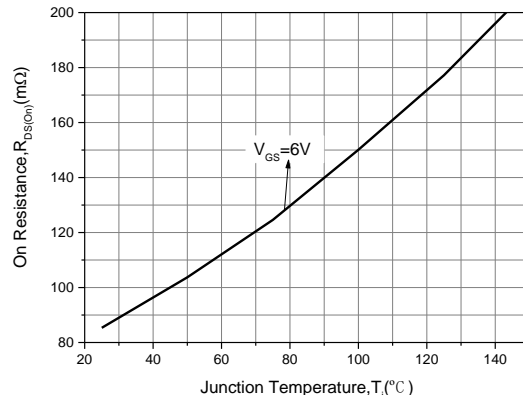

Figure 6. On-Resistance vs. Temperature

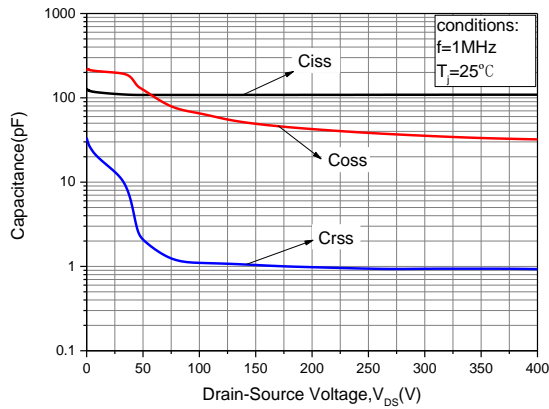

Figure 7. Capacitances vs. Drain-Source Voltage

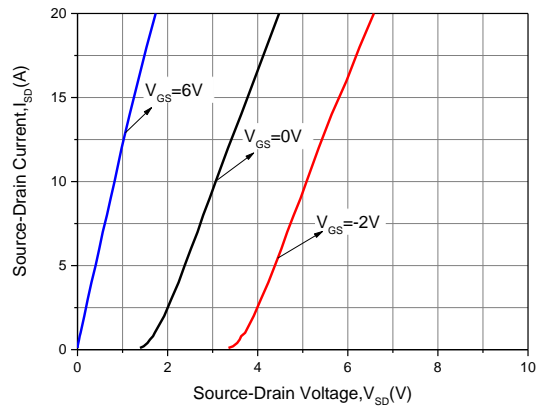

Figure 8. Channel Reverse Characteristic

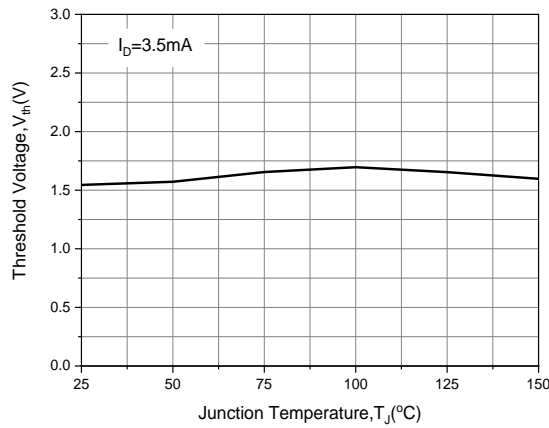

Figure 9. Threshold Voltage vs. Temperature

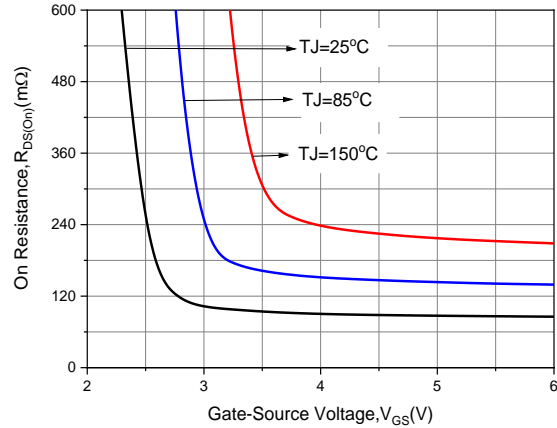

Figure 10. On-resistance vs. Gate Voltage @5A

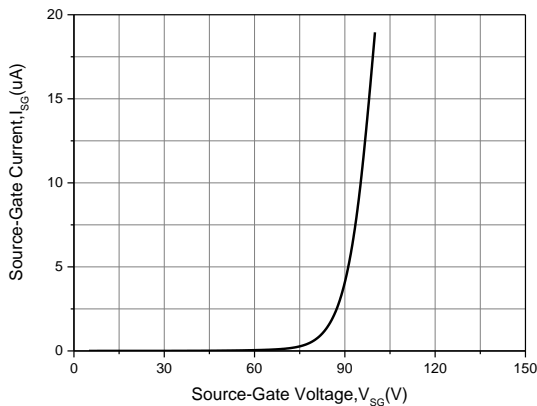

Figure 11. Reverse Gate Voltage

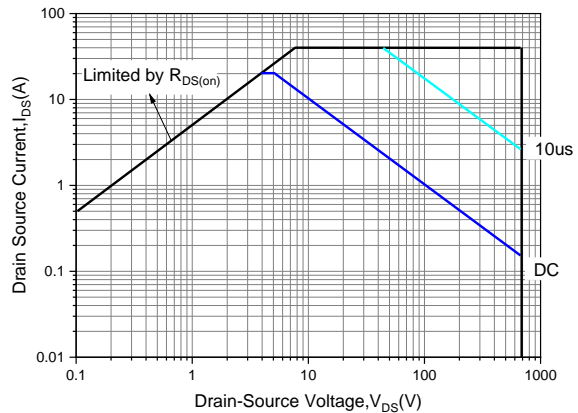

Figure 12. Safe Operating Area

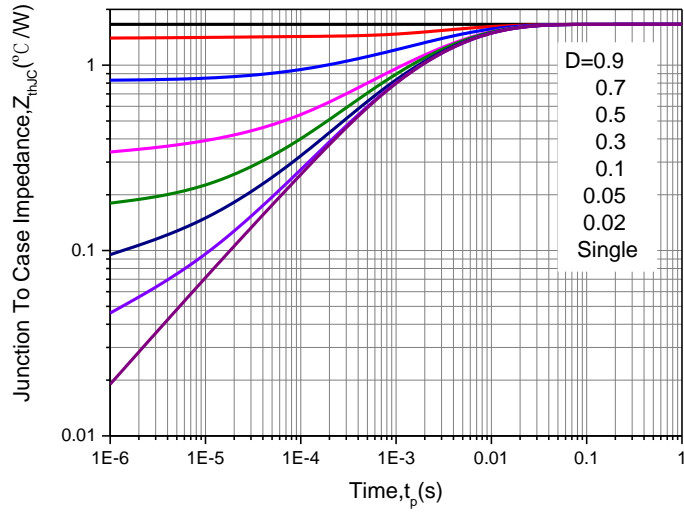
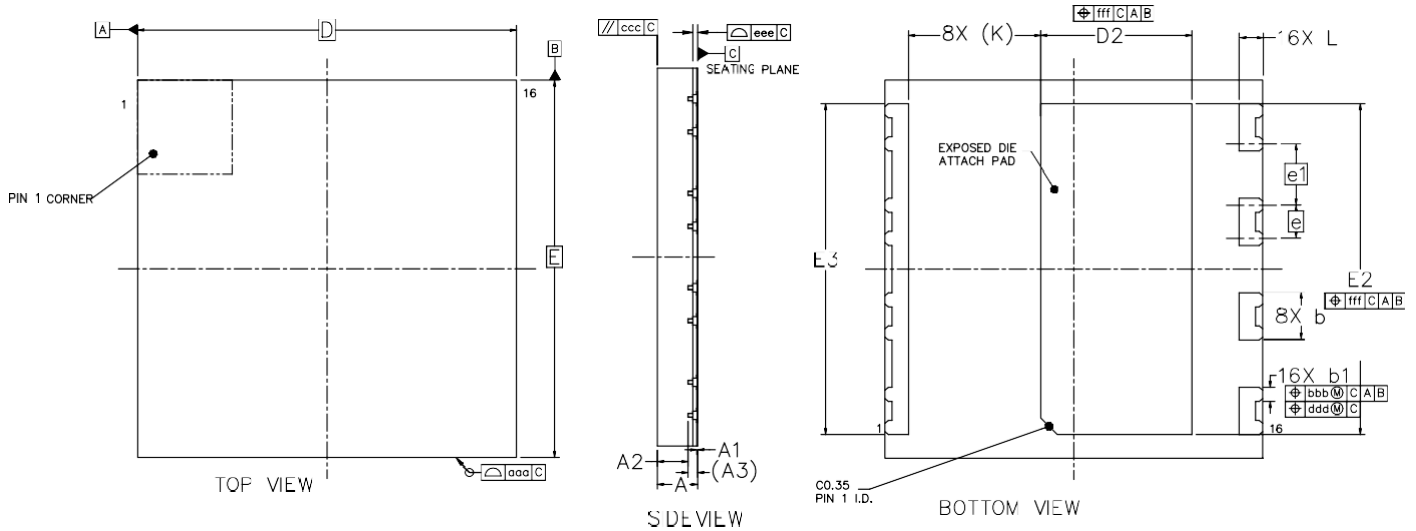

Figure 13. Transient Thermal Impedance (Junction-Case)

### Package Dimensions



	SYMBOL	MIN	NOM	MAX	
TOTAL THICKNESS	A	0.80	0.85	0.90	
STAND OFF	A1	0	0.02	0.05	
MOLD THICKNESS	A2	---	0.647	---	
L/F THICKNESS	A3		0.203		
LEAD WIDTH	b	0.90	1.00	1.10	
	b1	0.25	0.30	0.35	
BODY SIZE	X	D	8 BSC		
	Y	E	8 BSC		
LEAD PITCH	e	0.7 BSC			
	e1	1.3 BSC			
EP SIZE	X	D2	3.10	3.20	3.30
	Y	E2	6.90	7.00	7.10
	Y	E3	6.90	7.00	7.10
LEAD LENGTH	L	0.40	0.50	0.60	
LEAD TIP TO EXPOSED PAD EDGE	K	2.8 REF			
PACKAGE EDGE TOLERANCE	aaa	0.1			
MOLD FLATNESS	ccc	0.1			
COPLANARITY	eee	0.08			
LEAD OFFSET	bbb	0.1			
	ddd	0.05			
EXPOSED PAD OFFSET	fff	0.1			



Testing Conditions

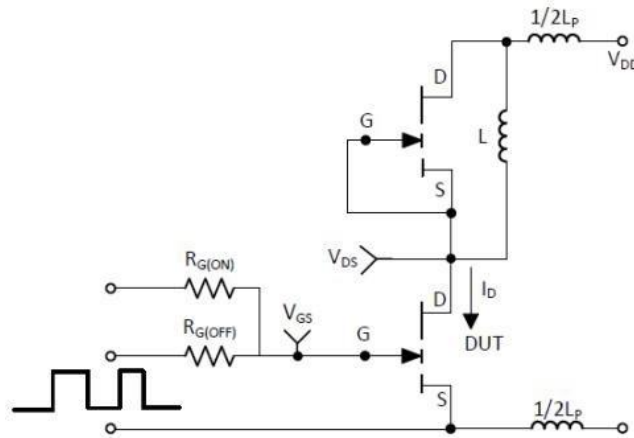

Switching Test Circuit

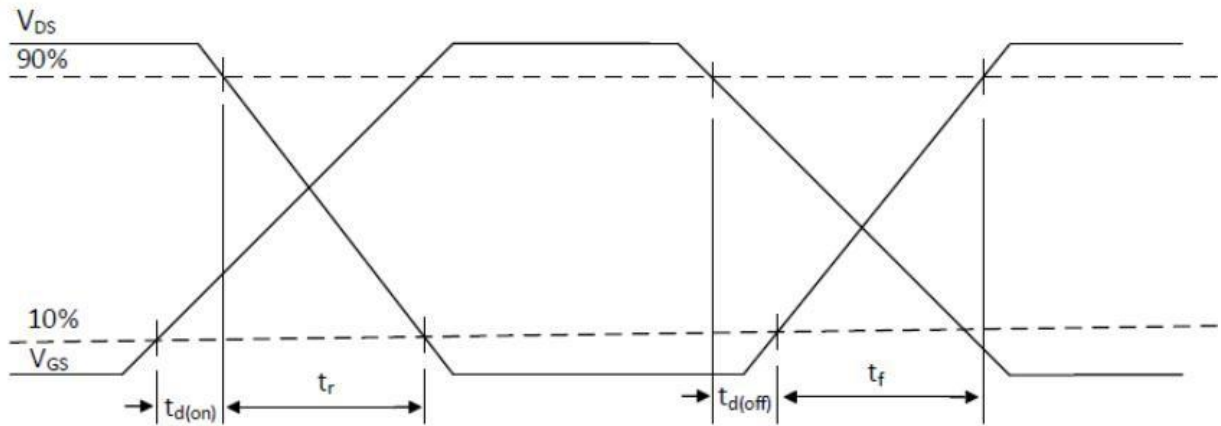

Switching Time Waveform

### Gate Driving Examples

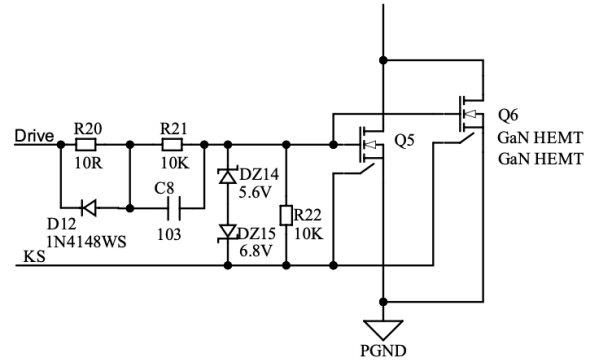
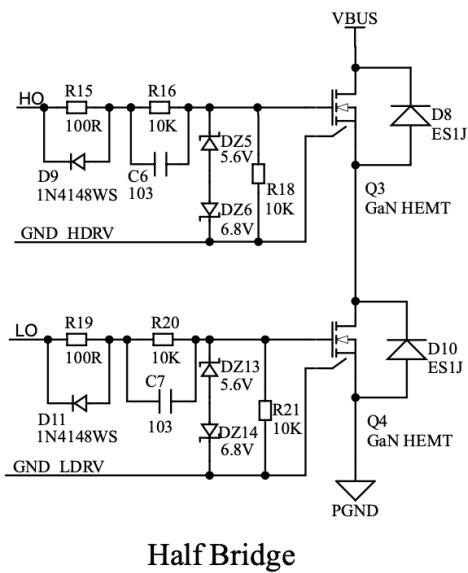

**Two Devices in Parallel**

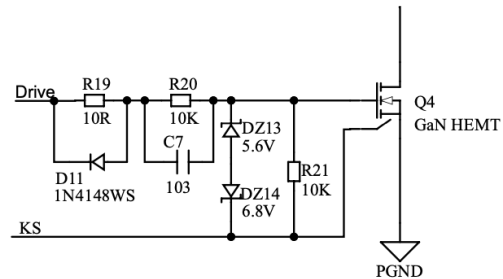

**Single Device**

## Revision History

Document revision	Date	Description of changes
2.7	2023.10.27	Target datasheet
2.8	2023.12.26	Updated ordinate in Figure7
2.9	2024.3.28	Add Vth @150°C
3.0	2024.4.8	Add Dynamic Rdson
3.1	2025.3.6	Revise Vth



X3G6509B8  
700V 82mΩ E-Mode GaN HEMT

---

## Important Notice

The information provided in this document is for informational purposes only and should not be construed as a warranty of condition, character, or performance under any circumstances. Xienergy disclaims any liability arising from the application or use of any of the products described herein, including but not limited to any personal injury, death, or damage to property or the environment. No license, patent or any other intellectual property rights are granted or transferred. Xienergy reserves the right to amend without prior notice. All rights reserved.

### Questions?

Email: [info@xienergy.com](mailto:info@xienergy.com)

Web: [www.xienergy.com](http://www.xienergy.com)

Tel: 1-778.588.1119

Copyright © 2024

Xienergy Systems, Inc.

Vancouver, Canada