

DESIGN NOTES

- DESIGNED IN ACCORDANCE WITH AASHTO HS20-44 TRAFFIC BRIDGE LOADING USING 5,500 PSI COMPRESSIVE STRENGTH CONCRETE AND 60,000 PSI YIELD STRENGTH ASTM A-706 STEEL REINFORCEMENT PER CALCS. #31602.
- COVER DESIGNED FOR 16,000 LB LOAD ON 10" X 20" FOOTPRINT, WITH 30% IMPACT RESTRICTED TO UNRESTRICTED PARKING LANES AND ALLEYWAYS WHERE TRAFFIC SPEED IS LIMITED TO 15 MILES PER HOUR. (ASTM LOAD LEVEL 5)
- MINIMUM EXCAVATION SIZE: 4'-0" X 6'-10" X DEPTH REQ'D.
- VAULT TO BE PLACED ON A MIN. 6" BASE OF CRUSHER RUN FOR EASE OF INSTALLATION AND EVEN LOAD DISTRIBUTION.
- ALL PARTS TO BE STENCILED: MFG DATE / JOB NUMBER / PRODUCT ID / WEIGHT.
- FOR COMPLETE DESIGN AND PRODUCT INFORMATION CONTACT JENSEN PRECAST.

BILL OF MATERIALS

ITEM	UNIT QTY	QTY	PART NUMBER	DESCRIPTION	MASS (lb)
1	1	1	100012119	Intercept 2436x8 Slab Bottom Sump Edison	1559
2	1	1	100012237	Intercept Riser 2436x27 Knockout Ducted Edison	1275
3	1	1	100012124	Vault 2436x6 Rect. Top Section 24"x36"C LADWP/EDISON	217
4	1	1	100006613	DAS1-SD-2436-D5-DP-P-RED-FONT-(SC2436-TRD)	157
5	1	4	100004349	BOLT HEX 1/2-13 UNC 2.5 304SS	
6	1	1	100006739	FONTANA NAME PLATE SS BLANK	
7	1	1	100007650	NAME PLATE HARDWARE KIT	
8	1.000 ul	1.000 ul	100005749	SEALANT JOINT BUTYL RUBBER ASTM C-990 AND M198 CS-102 1IN EQUIV X14.5FT PER BOX 118FT	

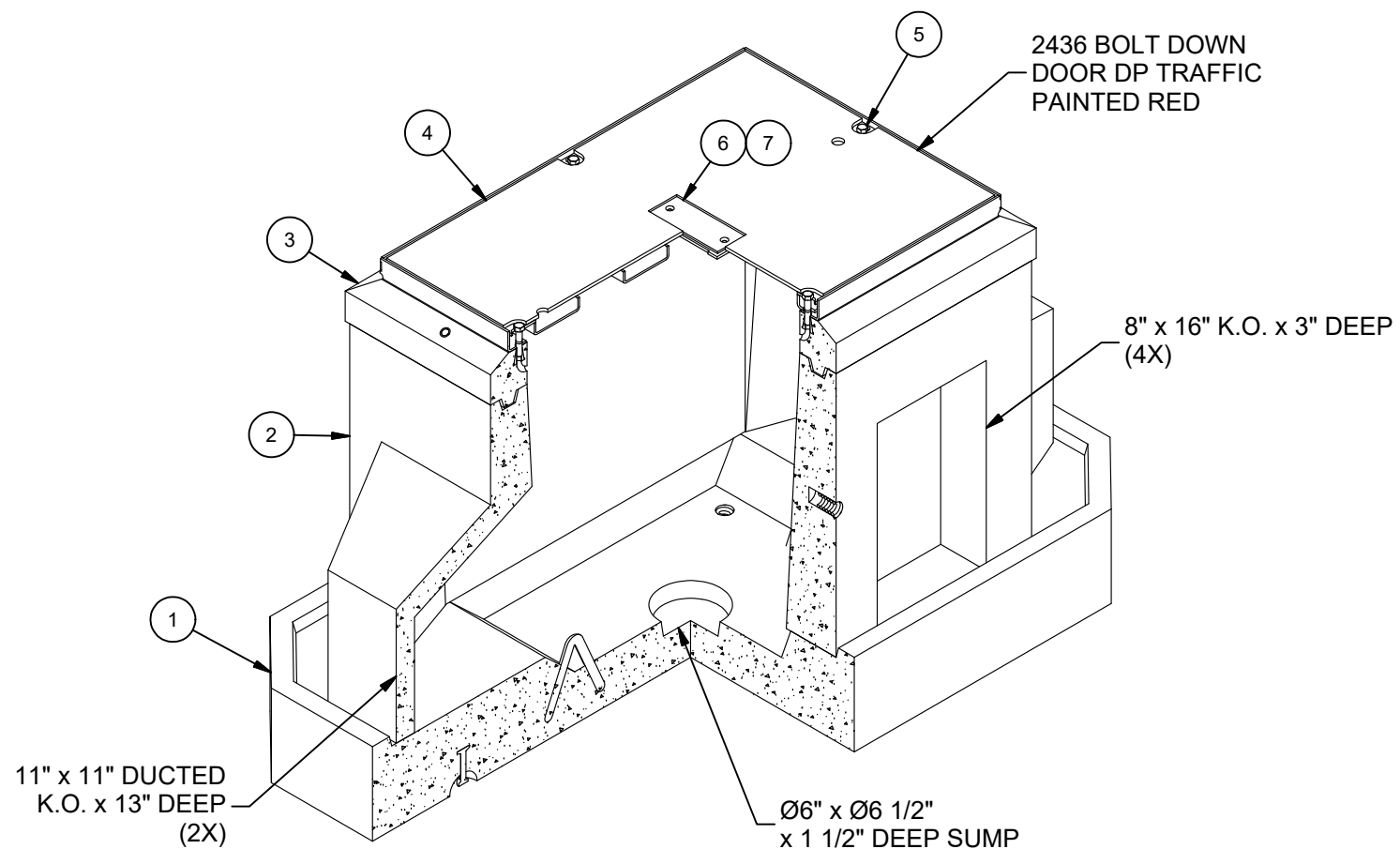

ISOMETRIC VIEW

LIFTING NOTES

- FIELD INSTALLATION: PLANT DEMOLDING: MINIMUM HANDLING CONCRETE STRENGTH F'c = 5500 PSI RIGGING EQUALIZER REQUIRED TO EQUALIZE LOAD TO 4 LIFTING POINTS WITH A SLING ANGLE BETWEEN 60° AND 90°

BURY DEPTH:	0.0' - 0.0' to Top
WATER LEVEL:	3.0'
DESIGN SPEC:	ACI 318, ASTM C857
AGENCY:	
APPROX. WEIGHT:	3209.98 Lbs
LOADING SPEC:	A-16 (AASHTO HS20-44)
AGENCY SPEC:	

**JENSEN PRECAST** EST. 1968  
[WWW.JENSENPRECAST.COM](http://WWW.JENSENPRECAST.COM)

©2024 Jensen Precast- All rights reserved. All materials appearing as Jensen Precast documents and the like are proprietary work product and are protected under U.S. copyright and other laws. Unless in conjunction with business conducted with Jensen Precast, any use of Jensen Precast work product without express, written consent is prohibited, and recipient is prohibited from distributing any and all work product to non-approved third parties under penalty of civil action.

REVISION HISTORY			
REV	DESCRIPTION	DATE	APPROVED
B-2	INITIAL RELEASE INVENTOR	6/13/2024	

DESCRIPTION:	Intercept Vault Layout 2436x36 Knockout Ducted, Sump 24"x36"C Traffic Painted Red	REV:	B-2
LAYOUT REVIEW		SHEET:	1 OF 2
PART NUMBER:	100010265	DRAWN BY:	J. Prado
CREATED:	3/20/2024	MODIFIED:	6/13/2024

100010265.rdw

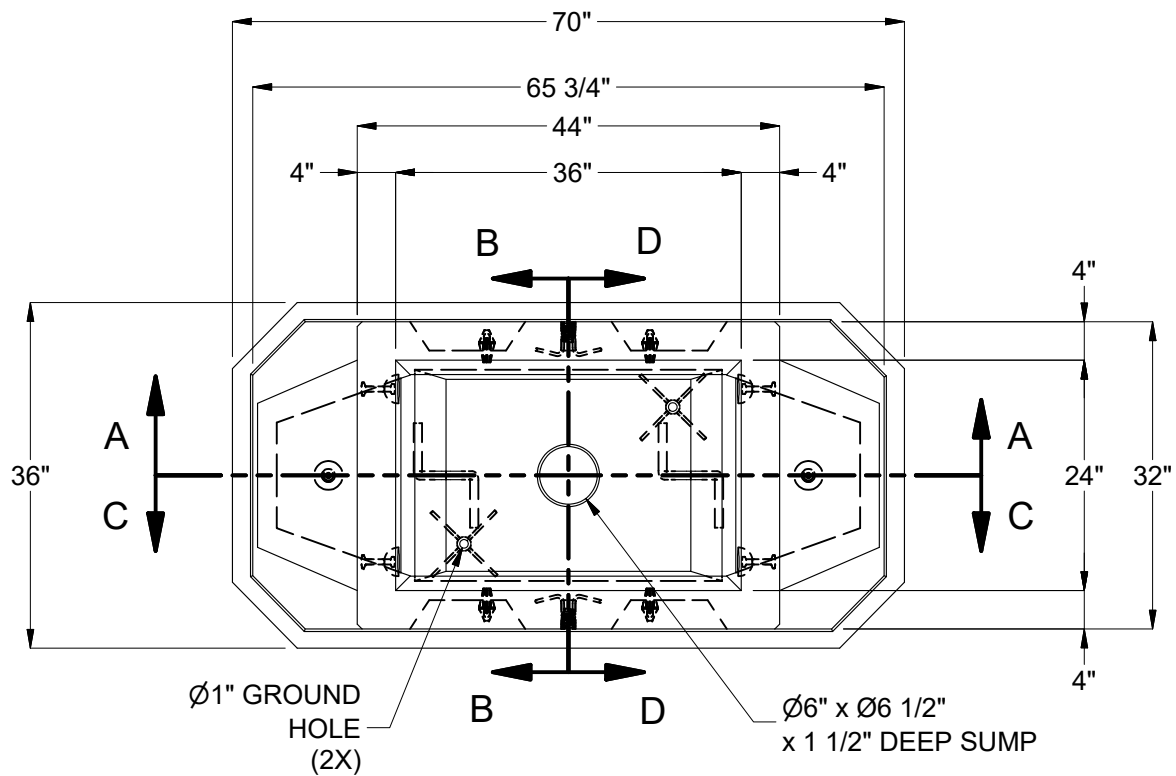

**PLAN VIEW W/O TOP SECTION**

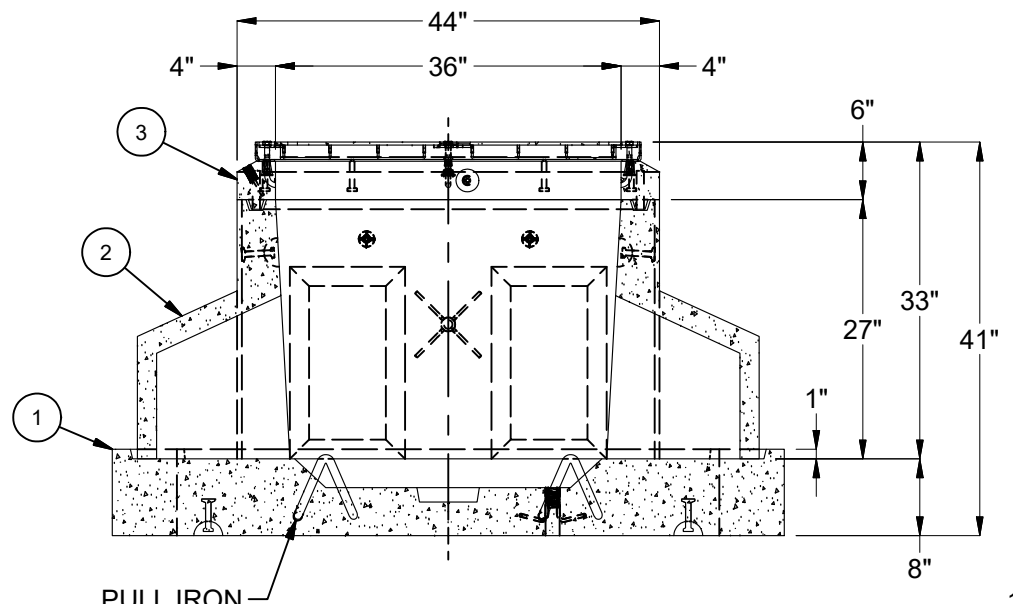

**SECTION A-A**

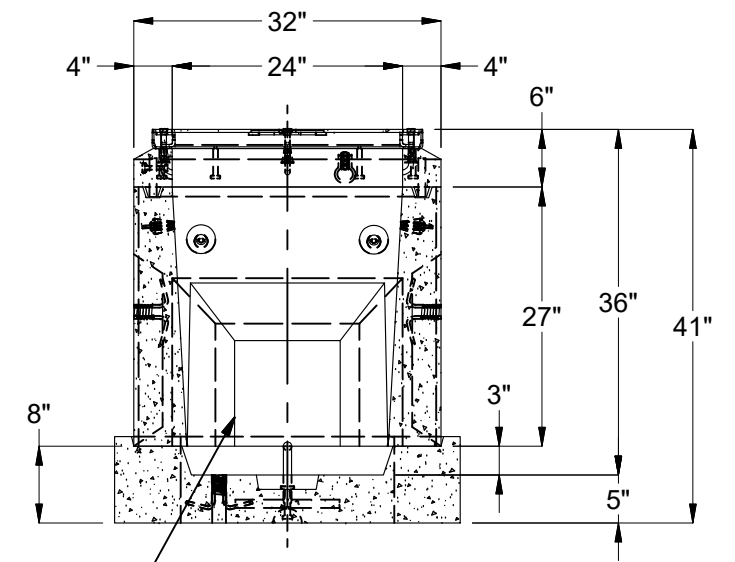

**SECTION B-B**

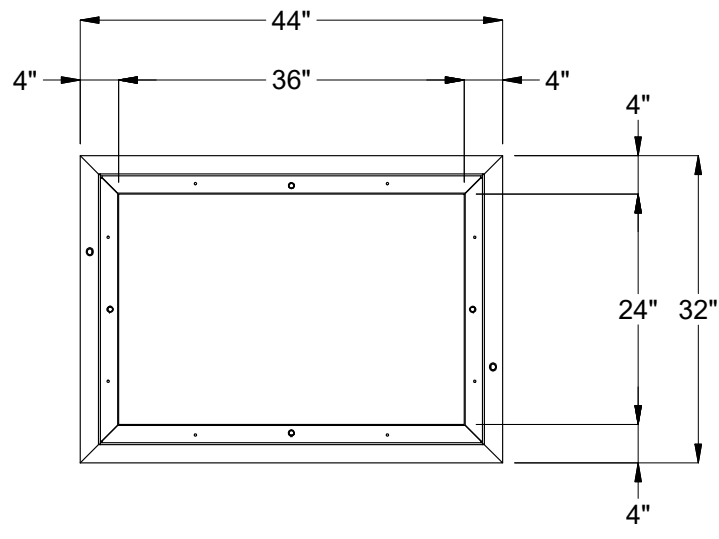

**PLAN VIEW OF TOP SECTION**

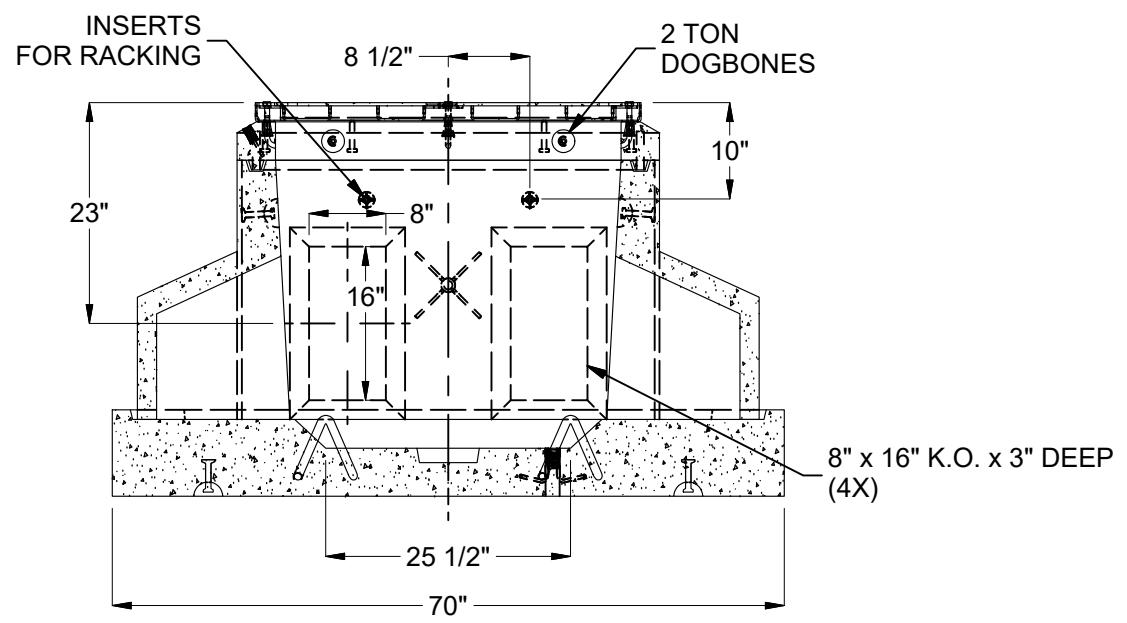

**SECTION C-C**

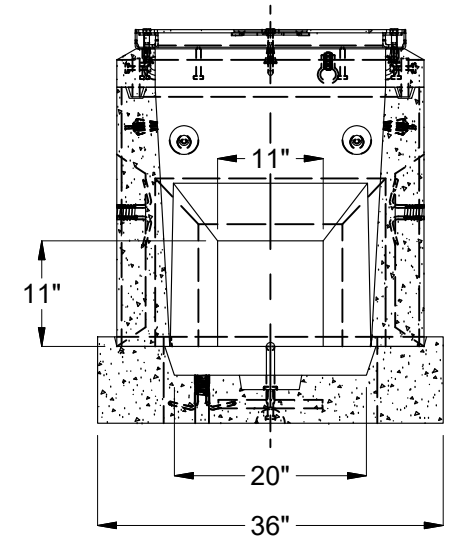

**SECTION D-D**

BURY DEPTH:	0.0' - 0.0' to Top
WATER LEVEL:	3.0'
DESIGN SPEC:	ACI 318, ASTM C857
AGENCY:	
APPROX. WEIGHT:	3209.98 Lbs
LOADING SPEC:	A-16 (AASHTO HS20-44)
AGENCY SPEC:	

**JENSEN PRECAST** EST. 1968  
[WWW.JENSENPRECAST.COM](http://WWW.JENSENPRECAST.COM)

©2024 Jensen Precast- All rights reserved. All materials appearing as Jensen Precast documents and the like are proprietary work product and are protected under U.S. copyright and other laws. Unless in conjunction with business conducted with Jensen Precast, any use of Jensen Precast work product without express, written consent is prohibited, and recipient is prohibited from distributing any and all work product to non-approved third parties under penalty of civil action.

DESCRIPTION:	Intercept Vault Layout 2436x36 Knockout Ducted, Sump 24"x36"C Traffic Painted Red	
PART NUMBER:	100010265	DRAWN BY: J. Prado
CREATED:	3/20/2024	MODIFIED: 6/13/2024

REV: B-2  
 SHEET: 2 OF 2

100010265.rdw