

2'-6" x 4' x 3' DUCTED INTERCEPT BOX

MODEL K3048-DI36-12

L.A.D.W.P. SPEC.
E-541 G2

NOTES:

STRUCTURE DESIGNED IN ACCORDANCE WITH:

- AASHTO H-20 TRAFFIC BRIDGE LOADING
- ASTM C-857 STANDARD PRACTICE FOR MINIMUM STRUCTURAL DESIGN LOADING FOR UNDERGROUND PRECAST CONCRETE UTILITY STRUCTURES
- AMERICAN CONCRETE INSTITUTE ACI 318-05

CONCRETE COMPRESSIVE STRENGTH $F'_c = 5500$ PSI

REINFORCEMENT IN ACCORDANCE WITH ASTM A-706 WITH A YIELD STRENGTH OF $F_y = 60,000$ PSI.

6" MINIMUM COMPACTED GRANULAR MATERIAL RECOMMENDED FOR SUB-BASE FOR EASE OF INSTALLATION AND EVEN LOAD DISTRIBUTION.

TRAFFIC COVER DESIGNED FOR H-20-44 TRAFFIC LOADING FOR OFF STREET USE ONLY.

PARKWAY COVER DESIGNED FOR PARKWAY LOADING OF 300 PSF.

1. PB3048-B-12, BASE SLAB, WT. 1,700 Lbs.
2. PB3048D-I27-12, INTERMEDIATE SECTION, WT. 1,223 Lbs.
3. PB3048-T6-12, TOP SECTION WITH GALV. ANGLE FRAME CAST IN WT. 213 Lbs.
- 4A. ONE PIECE PARKWAY POLYMER CONCRETE COVER, MARK "LADWP-E", WT. 236 Lbs.
- 4B. ONE PIECE TRAFFIC SLIP, WT. 236 Lbs.
- RESISTANT GALV. COVER, MARK "LADWP-E", WT. 236 Lbs.
5. 6" x 7" DIA. SUMP x 2" DEEP.
6. 14" x 14" DUCTED KNOCKOUT x 12" DEEP.
7. 8" x 16" KNOCKOUT x 3" DEEP.
8. 1/2" PLASTIC INSERTS.

(PB-1-INT) PARKWAY ASSEMBLY WITH RPM COVER K3048-DI36-12P.

(PB-2-INT) LIGHT TRAFFIC ASSEMBLY WITH STEEL COVER K3048-DI36-12I.

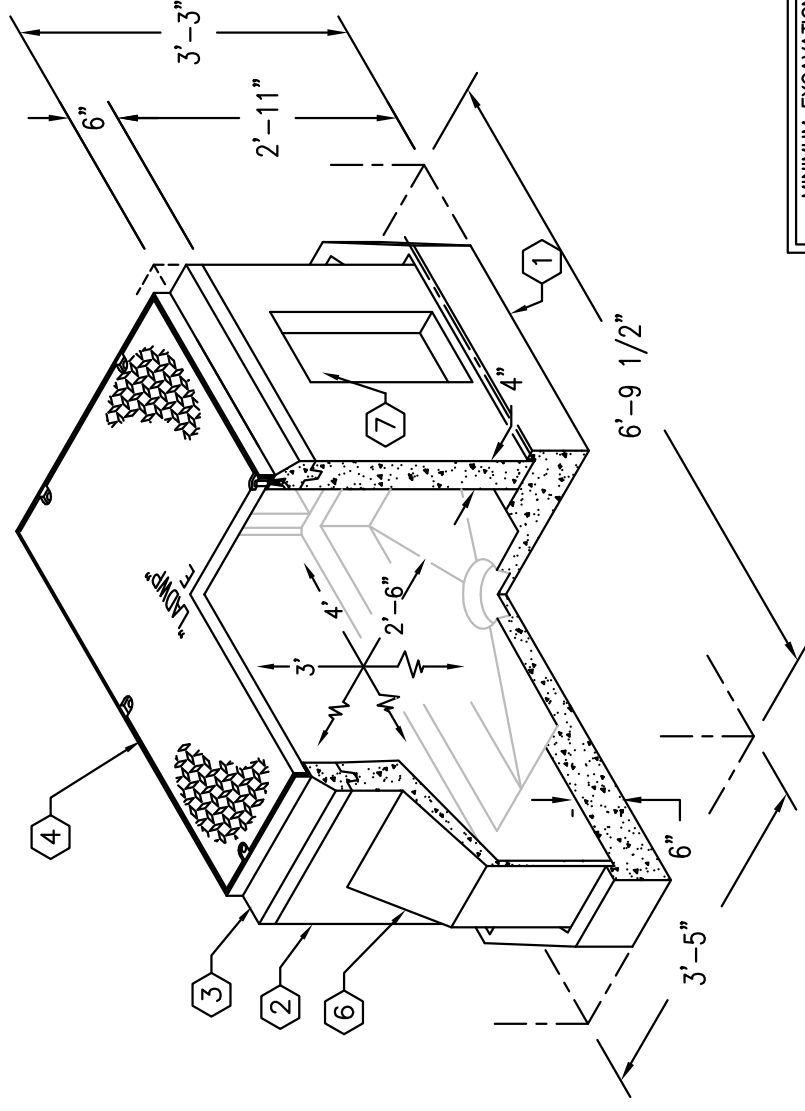

MINIMUM EXCAVATION SIZE:
4'-0" x 7'-3" x REQ'D DEPTH

2'-6" x 4' x 3' DUCTED INTERCEPT BOX

MODEL K3048-DI36-12

L.A.D.W.P. SPEC.
E-541 G2

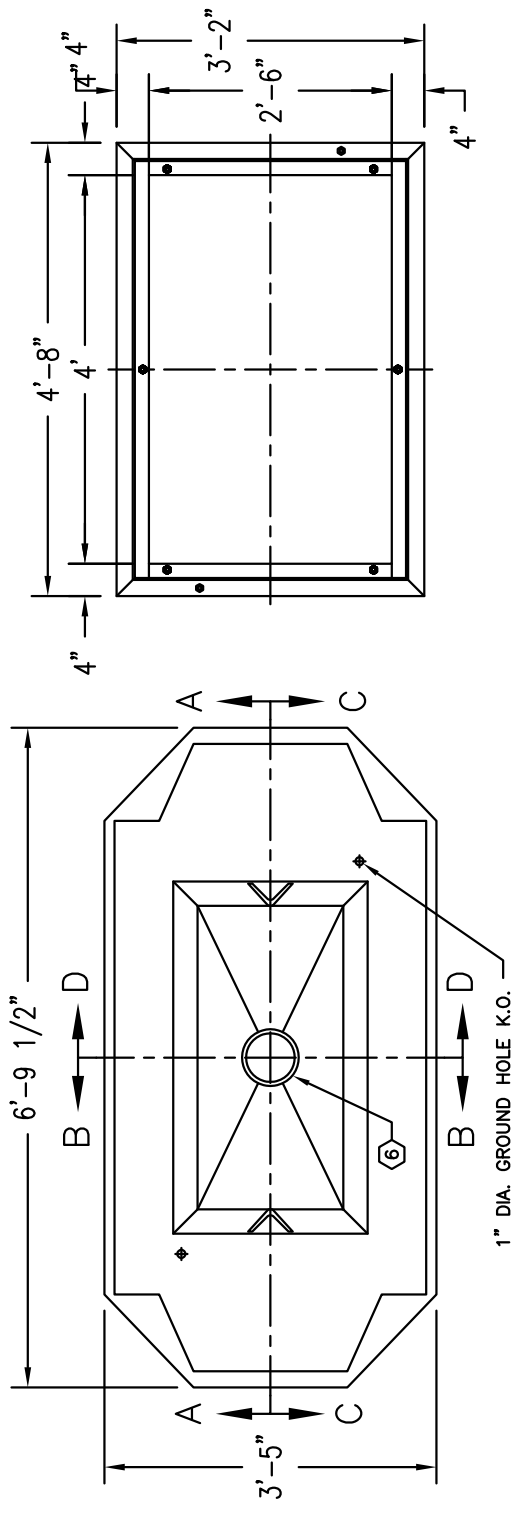

PLAN VIEW OF BOTTOM SLAB

PLAN VIEW OF TOP SECTION

NOTE: GRADE RINGS TO BE ADDED TO ACHIEVE DEEPER INSIDE HEADROOM

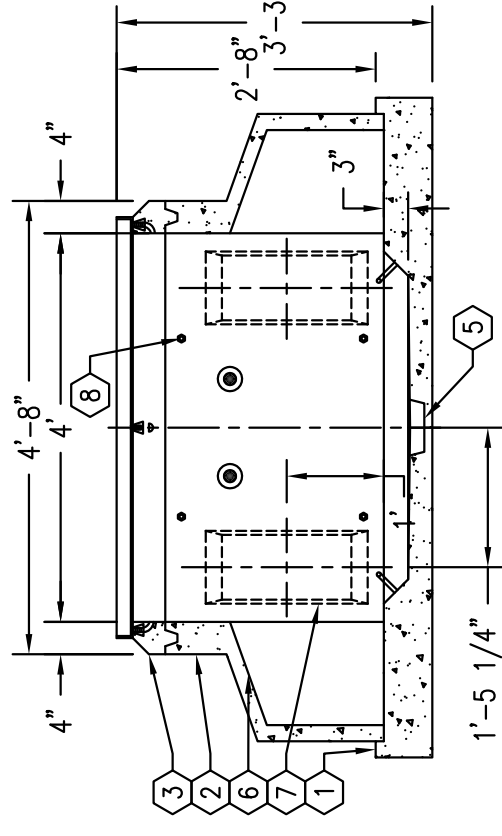

SECTION A-A/C-C

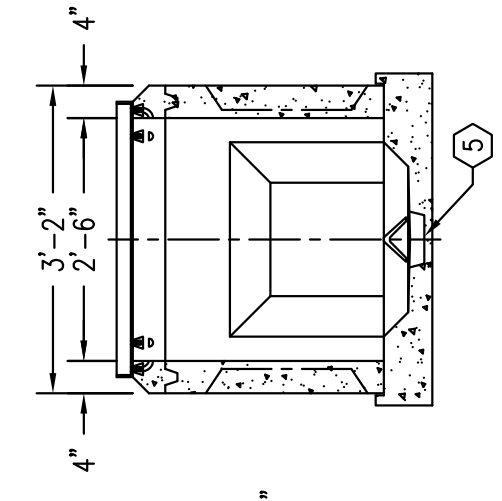

SECTION B-B/D-D