

Rose-Hulman Institute of Technology Rose-Hulman Scholar

Graduate Theses - Mechanical Engineering

Graduate Theses

5-2018

Aquaponic System Design and Modeling Ammonia Production: An Overview of Aquaponics

Spencer Davis Wright

Follow this and additional works at: https://scholar.rose-hulman.edu/mechanical_engineering_grad_theses

 Part of the [Mechanical Engineering Commons](#)

Recommended Citation

Wright, Spencer Davis, "Aquaponic System Design and Modeling Ammonia Production: An Overview of Aquaponics" (2018).
Graduate Theses - Mechanical Engineering. 11.
https://scholar.rose-hulman.edu/mechanical_engineering_grad_theses/11

This Thesis is brought to you for free and open access by the Graduate Theses at Rose-Hulman Scholar. It has been accepted for inclusion in Graduate Theses - Mechanical Engineering by an authorized administrator of Rose-Hulman Scholar. For more information, please contact weir1@rose-hulman.edu.

Aquaponic System Design and Modeling Ammonia Production:

An Overview of Aquaponics

A Thesis

Submitted to the Faculty

of

Rose-Hulman Institute of Technology

by

Spencer Davis Wright

In Partial Fulfillment of the Requirements for the Degree

of

Master of Science in Mechanical Engineering

May 2018

© 2018 Spencer Davis Wright



ROSE-HULMAN INSTITUTE OF TECHNOLOGY

Final Examination Report

Spencer Wright _____ Mechanical Engineering _____
Name Graduate Major

Thesis Title Aquaponic System Design and Modeling Ammonia Production: An Overview of

Aquaponics

DATE OF EXAM:

April 20, 2018

EXAMINATION COMMITTEE:

Thesis Advisory Committee	Department
Thesis Advisor: Zachariah Chambers	ME
Lorraine Olson	ME
William Weiner	BBE

PASSED X

FAILED _____

ABSTRACT

Wright, Spencer Davis

M.S.M.E.

Rose-Hulman Institute of Technology

May 2018

Aquaponic System Design and Modeling Ammonia Production: An Overview of Aquaponics

Thesis Advisor: Dr. Zachariah Chambers

The study of aquaponics in academia has been slowly gaining momentum, but the majority of the research and testing performed is done in an informal, backyard setting. This publication seeks to collate the widespread information into a singular location, as well as to outline various methods by which the necessary tasks can be accomplished.

The ammonia production rate of the aquatic life in the system, whether living or deceased, was also explored in order that a more accurate model of the ammonia and nitrate levels of the system may be created. It was found that 20 tilapia produced approximately 3,300 mg of ammonia in 11 hours with minimal to no feed provided. It was also found that a fish which had been dead for approximately 0.5 days produced approximately 0.83 mg of ammonia per hour, while two fish which had been dead for approximately four days produced approximately 6.309 mg of per hour.

Keywords: Aquaculture, Aquaponics, Tilapia, Ammonia, Parameterization

For Mom and Amelia, for everything you've done and all that you are.

Thank you to Carly Bobak and Herb Kunze, who provided the basis for my research and who answered all my questions. I really appreciate your help and clarification of key points in your work.

Thank you also to the Rose-Hulman Institute of Technology Mechanical Engineering Department, who helped fund the testing. Thank you for your generosity.

Thank you to Mr. Mat Pollom, who was my client for my senior design project on aquaponics. He was incredibly knowledgeable and helpful. He was willing to listen to and explore with outlandish ideas.

Finally, thank you to Dr. Zachariah Chambers, who has helped me so much with this project. He allowed me to explore different aspects of aquaponics and guided me through the testing. He provided the tilapia used in the testing and helped maintain and monitor the water levels. He was incredibly knowledgeable about aquaponics, and his expertise was incredibly helpful.

Table of Contents

List of Figures	iii
List of Tables	iv
List of Abbreviations	v
List of Symbols	vi
1. Introduction	1
2. Aquaponics Overview	2
2.1 Habitat for Aquatic Life.....	3
2.2 Habitat for Plants	5
2.3 Circulation.....	7
2.4 Aeration.....	8
2.5 Degasification.....	9
2.6 Clarification.....	10
2.7 Biofiltration.....	11
2.8 Example of Sustained Aquaponics System – University of Virgin Islands.....	14
3. Previous Literature	15
4. Experimental Design – Effects on a_2	19
4.1 Feed Amount Variations.....	21
4.2 Feed Protein Level Variations	22
4.3 Simulated Stocking Density Variations	22
4.4 Light Level Variations	23
5. Experimental Testing Procedure - Effects on a_2	24
6. Results – Effects on a_2	25
7. Experimental Design - Deceased Fish.....	27
8. Testing Results - Deceased Fish.....	27
9. Experimental Design – Multiple Fish.....	31
10. Testing Results – Multiple Fish	31
11. Further Work.....	35
12. Conclusion	36
List of References	38
Appendix A – Figures of Specification Solutions	43

LIST OF FIGURES

Figure 1. The layout of the University of the Virgin Island’s aquaponics system [22].....	14
Figure 2. The original plot of the fish and plant population [1]	18
Figure 3. The original plot of the ammonia and nitrate levels [1].	18
Figure 4. The plot of the fish population and the plant population for the given coefficients	18
Figure 5. The plot of the ammonia and nitrate levels present in the water	18
Figure 6. Plot of the Ammonia Data from the Deceased Testing	29
Figure 7. Plot of the Ammonia and Nitrite Levels for the IBC Testing in ppm	33
Figure 8. Plot of the Nitrate Data from the IBC Testing in ppm	33
Figure 9. An industrial 55-gallon drum [29].....	43
Figure 10. A 275-gallon intermediate bulk container (IBC) [30].....	43
Figure 11. A 300-gallon stock tank [31].....	43
Figure 12. Plants growing through a Styrofoam sheet demonstrating deep water culture farming [10].....	43
Figure 13. Plants grown using the nutrient film technique [32]	44
Figure 14. Plants growing in a media (or aggregate) grow bed [10]	44
Figure 15. An air stone accomplishing aeration and degasification [33]	44
Figure 16. An oxygen saturation cone cross section [34].....	44
Figure 17. Diagram of a Bakki shower showing the inner workings [35].....	45
Figure 18. A spray bar accomplishing aeration and degasification [36]	45
Figure 19. An example of a swirl filter, though many different configurations are usable [37] ..	45
Figure 20. A baffle filter where the arrow’s path demonstrates the water’s flow and solids leave through the lower pipe [22].....	45

Figure 21. An example of one configuration of a settling tank [38].....	46
Figure 22. An auger screw, which could be used for clarification by being placed in a pipe and rotated, acting as a baffle filter [39].....	46
Figure 23. A simplistic drum filter, where water enters at the top and the water sent to the grow beds comes out through the center of the inner basket [40]	46
Figure 24. One type of bio-balls, though there are numerous other examples [41]	46

LIST OF TABLES

Table 1. Results of the Deceased Fish Testing in ppm.....	28
Table 2. Results of the IBC Ammonia Level Testing.....	32

LIST OF ABBREVIATIONS

ppm – Parts Per Million

FCR – Feed Conversion Ratio

IBC – Intermediate Bulk Container

LIST OF SYMBOLS

F – the fish population

A – the amount of ammonia present in milligrams

N – the amount of nitrate present in milligrams

P – the plant population

a_1 – a coefficient which represents the birth and survival rate of the fish

a_2 – a coefficient which represents the rate at which fish produce ammonia

a_3 – a coefficient which represents the amount of ammonia converted each day

a_4 – a coefficient which represents the amount of nitrate made from ammonia each day

a_5 – a coefficient which represents the nitrate consumed by plants each day

a_6 – a coefficient which represents the rate at which plants grow

K_F – the system's carrying capacity for fish

K_A – the amount of ammonia, if present in the system that would be fatal to the fish

K_P – the system's carrying capacity for plants

1. Introduction

Aquaponics is a form of farming which produces vegetables and seafood within a relatively small area. It is a very open-sourced area of agriculture, with most farmers helping each other solve problems and respecting the intellectual property of other farmers. In aquaponics, fish live in tanks filled with water and are raised for profit as well as to produce waste. A portion of this waste is ammonia, which is converted by bacteria to nitrite before another type of bacteria converts the nitrite to nitrate. The nitrate is much less harmful to the fish than either the ammonia or the nitrite, and the nitrates are then sent through the water system to grow beds full of plants. The foliage consumes the nitrates in order to grow and flourish, thereby cleaning the water for the fish to use again, and so the aquaponics cycle restarts.

Since aquaponics is a more grassroots area of study as opposed to an academic, more streamlined field, there is a great deal of research being done outside of a laboratory setting, and the information is very widespread. Though a shift is taking place having aquaponics become more of an academic field as well, this change is slow moving. Part of the goal of this publication is to coalesce a portion of the available information into a more academic introduction to aquaponics. For example, the various tasks performed in an aquaponics system are laid out and explained, and examples of solutions are given. It has been found that there are many conflicting opinions as to what options work best, and it mostly comes down to a case-by-case basis and individual preference. What works for one individual will not work for others, whether that is due to different species of fish, different plants, slightly different configurations, or any number of factors.

The second portion of this paper will focus on a model of an aquaponics system put forth in the publication “Modelling an Aquaponic Ecosystem Using Ordinary Differential Equations” by Carly Bobak and Herb Kunze [1]. The equations presented in the paper can be used to model the ammonia and nitrate levels present in the aquaponics system, as well as the fish and plant populations. This model utilizes coefficients throughout that define various rates found in the physical aquaponics system. Many of the coefficients have specific values identified based upon chemistry or extensive literature review performed by those authors, but a few values were chosen as very rough estimates. The inexact coefficient used to determine the rate of ammonia production by the fish was investigated. Experiments were designed to greater explore the extent of the effects various factors have on the value of this coefficient, but the testing in its current configuration did not yield reliable results. Testing was also performed to measure the amount of ammonia produced by deceased fish, and a separate trial was run using a large group of live fish in a tank as a test case for the experiments designed.

2. Aquaponics Overview

The systems used in aquaponics farming can be as simple as a single tank with plants floating above fish, or more detailed than entire warehouses converted to a vertical farming area. Regardless of the complexity, the two main goals are almost always to grow plants and seafood for profit. To accomplish this goal, there are two basic tasks which must be completed: providing a habitat for the plants and providing a habitat for the aquatic life. There are also five less intuitive tasks which must be accomplished in order for the fish and plants to survive until they are of a harvesting age, which are circulation, aeration, degasification, clarification, and biofiltration [2]. Each of these five tasks is of equal importance as without any of them a system cannot function properly. Each task comes with specifications which must be met, and has many

different ways in which it can be accomplished. Example pictures of the various solution methods are given in Appendix A.

2.1 Habitat for Aquatic Life

The aquatic habitat and the floral habitat are the two most significant aspects of the aquaponics system since they generate profit. Additionally, the fact that these areas support the bulk of the life in the system, with the only other life being bacterial, the specifications they set tend to determine the conditions for the rest of the system. While there are some similarities between the two habitats in terms of the requirements that must, each also has distinct and diverse needs as well.

The pH of the water in the system is a prime example of a shared specification, as both the plant life and the aquatic life require different pH levels to thrive. Often these levels directly contradict each other, such as a certain breed of fish requiring a pH of around 8, while a species of plants may require a pH closer to 6, as plants prefer acidic conditions and fish prefer alkaline conditions [3]. To reach a pH more agreeable to both the plants and the animals, it is best to pick both the types of plants and the types of fish together so that the required pH can be taken more into account, thereby balancing the system.

One of the most important specifications for the fish habitat is that the ammonia level must stay below 0.98 ppm as prolonged exposure can be lethal to tilapia (the most common fish used in aquaponics) [4]. Preferably, the ammonia level should be kept as close to 0 ppm as possible, though very short periods of time at higher ammonia levels, such as 4 ppm are survivable [4]. The other key in regards to the fish habitat is the level of dissolved oxygen present in the system, as 4 to 5 milligrams per liter is generally required [5]. Some species of fish

may require higher levels than this, but this standard can be used as a general starting point. It is always highly recommended that research is done on the specific breed of fish being selected for the system to tune in to the more exact needs of that species.

The level of nitrite (produced through the decomposition of ammonia as discussed later in the biofiltration section) should be kept near 0 ppm, and the nitrate level can reach 20 ppm to 100 ppm depending on what source the information is drawn from [6, 7]. The temperature of the water is dependent on the specific breed of fish selected, but it must be considered as well.

Another important factor to consider when selecting a type of fish to raise is their feed conversion ratio, or FCR, which determines approximately what portion of the food, by mass, gets converted directly into mass gained in the fish. It is a unitless value that has vast implications for selecting the fish to farm and is calculated by dividing the mass of the food given to the fish by the mass gained by the fish [8]. Therefore, a higher FCR is less optimal, since more food, and therefore more production costs are used to grow the fish to harvest weight.

The “stocking density,” or amount of water per pound of fish, is another concern since the less water available per fish, the faster chemical levels can fluctuate, meaning the water may become toxic without much warning. Therefore, a stocking density of approximately eight gallons per pound of fish is recommended for less experienced aquaponics farmers, while some more experienced farmers may be able to get the stocking density down closer to two gallons per pound of fish [9]. A lower stocking density is optimal as the more fish that are successfully raised, the higher the profit come harvest time. Conversely, if a farmer seeks a stocking density below their ability to handle, they may lose a significant portion, if not all of their crop due to being unable to counter the fluctuation in nutrient levels properly.

The light level present in the tanks is another factor that must be regulated. Fish become uneasy when subjected to too little light [10]. If the fish are not content, they will not eat as much and will not grow as quickly. Conversely, if the fish tanks are subjected to light which is too strong, algae may begin to grow on the surface of the water, depleting the oxygen levels in the water which could be lethal for the fish [10].

Even with this myriad of specifications, there are still limitless possibilities when it comes to housing fish. Industrial 55-gallon barrels could be used, and 275-gallon intermediate bulk containers (IBCs) work very well. Concrete could be poured to form troughs in which the fish could be housed, or aquarium tanks could be employed in smaller aquaponics systems. 300-gallon stock tanks could be used, or any size and shape of container could be custom made from fiberglass or plastic. Even bathtubs and swimming pools work very well. While all the detailed specifications must be met, the containers must also be deep enough to allow the fish to thrive, and not be so small such that the fish are not free to move. Images of some of the less well-known solutions are provided in Appendix A.

2.2 Habitat for Plants

Plants are not as complex as aquatic life, so it is expected that they have fewer stipulations than the marine life. As stated earlier, the pH level of the system's water is a balancing point for the two habitats, and generally, plants prefer a pH around 6 [3]. The type of plant grown also can affect what temperature the environment should be kept at, due to cool-season plants thriving in a colder temperature (50°F to 70°F), while warm-season plants need slightly warmer temperatures (60°F to 80°F) [11]. Therefore, keeping the air temperature at approximately 65°F should satisfy both types of plants, allowing for a more diverse range of crops to be grown

simultaneously. Plants prefer light in the blue and red spectrum [12]. Many grow lights are specially designed to put out light in these desired spectrums to supplement any ambient lights.

Along with all of these environmental conditions, there are additional stipulations for the other nutrients which must be present in the water. As discussed later in the biofiltration section, the plants will be receiving nitrates already, but the other major nutrients they require are phosphorus, potassium, calcium, magnesium, and sulfur [13]. They also require minor amounts of other nutrients, such as iron, manganese, boron, zinc, copper, and molybdenum [13]. While these may occur naturally in the system from the fish or the environment, it is highly recommended that these levels be tested, or at the very least, supplements are added to ensure the necessary levels are equal to or exceeding the requirements. The required levels are not consistent, varying between each species of plants, so it is best that this is researched prior to beginning to plant a new crop.

To successfully provide a home for the plants, there are three methods that are commonly used, and many other possibilities for housing the plants. One of these widespread methods is deep water culture farming which utilizes floating raft grow beds. In this configuration, no media is provided to grow the plants. Instead, the plants are placed in holes cut into a material with a low density such as Styrofoam or foam board. The plants then have their roots placed in the nutrient-rich water so as to soak up the necessary compounds.

The floating rafts allow farmers to harvest plants or maintain the environment easily by removing whole sections of plants. Sometimes, these floating rafts are placed directly on the surface of the fish habitat, especially in smaller systems to save space. But this method also prevents the plants from being packed tighter together. The more compact the plant population is, the higher the yield, which means the pre-determined spacing with this method is a drawback.

Another variation similar to this is called the nutrient film technique where plants are placed in shallow cups with large holes which allow the roots to dangle through. These cups are then placed in holes cut into the tops of piping, and water flows through the interior of the pipe, allowing the plant's roots to soak up the necessary nutrients as they dangle down into the flowing water. This method has the same drawback as the deep water culture farming though, in that plants are forced to be more spread out based on the construction of the piping.

An alternative to the floating raft and nutrient film techniques is aggregate beds, where a media such as volcanic lava rocks is provided for the plants to sprout and take root. The media then have water sent through it, navigating the naturally occurring channels to bring the nutrients to the roots. Plants grown in this type of environment are harder to harvest, as whole sections cannot be removed at once. The media may also become too compact if the wrong material is chosen, such that water is not able to permeate the growbed. This process is known as compaction, and will most likely occur naturally over time as well regardless of the media used as the aggregate begins to settle. Again, pictures of the example solutions to many of these tasks are given in Appendix A.

Once these two tasks have been planned out, it is recommended that the five less intuitive goals be accomplished, circulation, aeration, degasification, clarification, and biofiltration. These tasks are vital to the survival of the plant and aquatic life, and without even one of these, a standard aquaponics system will fail.

2.3 Circulation

Just like a heart circulates blood throughout a body, so too an aquaponics system needs a pump of some kind to circulate water throughout the system. The main specification for the

pump is that the water in the system must be completely “turned over” or cycled through the whole system a set number of times per hour. The number of times the water must be turned over is determined by a number of factors, from species of aquatic life to types of plants grown, to the size of the system. Generally, a rough estimate of turning over all the water in the system one or two times per hour is acceptable. There are many different types of pumps, from electric pumps to air pumps, to gasoline-powered pumps, and each can accomplish this task. Each type has its own advantages and drawbacks, and there are certainly other methods of moving the water through the system that have not been listed here.

2.4 Aeration

The process of aeration involves air being forced into the water, increasing the dissolved oxygen levels. In general, approximately 4 to 5 milligrams per liter of dissolved oxygen are needed for the fish [5]. The key is the need for smaller bubbles being formed further down in the tank [14]. This allows for a greater surface area to volume ratios meaning the bubble can be absorbed more quickly, and the oxygen would have more time to be absorbed by the water as the bubbles float up from a greater depth. The increased pressure at lower depths will also force the bubbles to be smaller. Any bubbles which reach the surface are unused for aeration, and the energy used to form them was also wasted, meaning lost production costs. Aeration in its simplest form is simple to accomplish, as there are numerous ways to make bubbles in water.

Airstones connected to a pump force oxygen to the bottom of the tank and allow it to bubble up. Venturis have also been used to create bubbles in the flow being constricted [10]. Oxygen saturation cones greatly oxygenate the water, but pure oxygen must be fed into the device, increasing costs [15]. A structure called a Bakki shower can be used, where the water pumped to the top of a six to ten-foot structure, filling a shallow trough. The trough has holes in

the bottom which allow the water to drop into another trough below, which also has holes [16]. The water continues to drop down through successive layers to the bottom oxygenating the air and degassing the water (discussed in the next section) [16].

Water can also be sent to the grow beds through spray bars, which allow smaller amounts of water to fall into the beds, creating bubbles. Mechanical aeration devices, such as propellers, can be used, though these tend to be more expensive and not as widely utilized. Any method that has water splashing will introduce bubbles, and therefore, oxygen.

2.5 Degasification

In the biofiltration portion of the tank, there are helpful nitrification bacteria, but also sulfate-reducing bacteria that produce hydrogen sulfide in anaerobic conditions, a compound deadly to fish [10]. The process of degasification helps to prevent the build-up of hydrogen sulfide by removing carbon dioxide, hydrogen sulfide, methane, and nitrogen gas from the system [17]. Depending on the plants grown, removing the nitrogen may be counterproductive as leafier plants need more nitrogen [10]. As such, most systems are not large enough to warrant a special degassing tank, and this is usually combined with aeration in that the bubbles produced in aeration accomplish the degasification process as well. The grow beds also can function to degas the water as the water mixes with plenty of exposed air to release the harmful chemicals.

The presence of a rotten egg smell from the hydrogen sulfide is usually an indication a degassing tank is needed, there are many different options [10]. A separate tank with airstones would work to allow the hydrogen sulfide to bubble out, and aerate the water as well. If a less conventional route is sought, a Bakki shower can be used as discussed in the aeration section.

In aeration, the goal is to have no bubbles reaching the surface, indicating maximum efficiency. Conversely, degasification relies on many bubbles reaching the surface to remove the harmful gasses, creating a trade-off. Regardless of the amount or size of the bubbles which escape, most systems still allow the water to be exposed to the atmosphere enough to sufficiently degas the system.

2.6 Clarification

Clarification is the process by which solid waste is removed from the flow of water from the fish to the plants. If the solid waste is not removed, it could clog the pipes in the system leading to a catastrophic failure. Alternatively, if the solid waste did make it through the pipes to the plant habitat, the toxins in the waste could harm the foliage. Depending on the clarification system used, heterotrophic bacteria could be introduced, which would break down the solid matter in the waste [10]. Even if the bacteria are present and no other clarification is used, there would still be too large of a quantity of waste to break in all but the smallest systems, necessitating the inclusion of a separate chamber to deal with the solid waste.

There are many different methods of performing this task. Swirl filters are commonly used due to their ease of construction. These are where the water enters a circular barrel at an angle close to tangent to the barrel's curvature. This then causes a weak vortex effect in the water which pulls the solid waste to the bottom. The cleaner water then exits the barrel. Another method used is a baffle filter, where the water is sent into a tank perpendicular to a flat plate, removing most of the water and waste's momentum in the impact. This causes the solids to settle to the bottom as they are unable to regain enough momentum to exit the tank. Settling tanks, as a third option, are commonly used in septic systems to remove human solid waste, but smaller versions could be easily applied to aquaponics systems. A drum filter can be used, which acts

somewhat like a reverse sieve with a larger container housing a smaller, internal container with holes in it. The water enters the larger container so the solids will settle in the outer container and the water is then pulled into the inner container through suction and sent to the plants [18].

There are also all sorts of mechanical separators which could be used. Centripetal force could be employed to force the more dense solids to the outer edge for extraction. If there are sufficiently few fish for the number of plants, aggregate grow beds could be used to provide a home for bacteria to break down the minute amount of solid waste. An auger screw could be inserted into a pipe with the wastewater flowing past, acting like a rotating baffle filter system. No single method of clarification is best; each has advantages and disadvantages, and the method of clarification is very much so dependent on each individual system, the space allotted, the maintenance which can be performed, and many other factors.

2.7 Biofiltration

Biofiltration is the other stage of filtration that must be accomplished. While the clarification step removes the large solid waste, the biofilter removes the ammonia excreted by the fish. Ammonia is useless to the plants and highly toxic to fish, even at levels as low as 0.98 ppm over extended periods of time [4]. The ammonia enters the biofilter, and bacteria converts the ammonia to nitrite [10]. Unfortunately, nitrite is still highly toxic to the fish, and levels of nitrite as low as 0.1 ppm can be fatal to some catfish, though other types of aquatic life have a higher tolerance [19]. Fortunately, a secondary bacterial process converts the nitrite into nitrate, which is not harmful to the fish unless it is present in high concentrations (20 ppm to 100 ppm depending on the source), and the plants can absorb this compound as nutrients to grow and flourish [7]. These processes are demonstrated in the two chemical equations shown below, Equation 1 representing the first process, and Equation 2 detailing the second process [20].

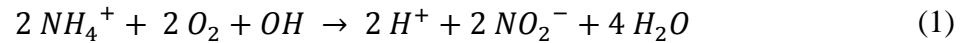

The bacteria require the surface area to make their home on, and can even be found in the air. They are blown into a system and will begin to multiply in the presence of their food.

Unfortunately, this establishing process takes time, and the fish may be producing ammonia faster than the bacteria can keep up in newly started systems. This is why it is advisable to slowly ramp up a new system and allow the bacteria a lead time to have a large enough population to deal with the amount of ammonia produced when the system is at full capacity. As a way to jump-start a new system, water from an existing system can be taken and added to a new system, as the old system's water will already have the necessary bacteria. This sudden influx of bacteria would still need time to establish itself, so it is not an instant solution, but it does decrease the necessary ramping up period. Alternatively, if there is an available system which employs aggregate grow beds, some of the media from that system can be added to the newer system, having approximately the same effect as adding the water from the old system.

A system should also be designed with more biofiltration than is required. If there is not enough bacteria, the system will continue to accumulate ammonia, leading to fish fatalities. Additionally, the bacteria will never be able to catch up to the necessary population to handle and process the excess ammonia. The bacteria also require the surface area to grow, and if this is not provided, the system will begin to fail. Therefore, it is always advisable to create a larger biofiltration component than needed, whether that be increasing the size of the biofiltration chamber, or adding a separate chamber if none was present before. The nitrifying bacteria also prefer darkness, so darkening the biofilter will also help it function at a higher capacity [21].

Some systems just use aggregate grow beds, and the media in these beds provides a home for the bacteria, allowing the system not to need a separate biofilter chamber. If the system is small enough, aggregate grow beds are not even necessary for biofiltration, as there is enough surface area on the piping and walls of tanks for the bacteria. This is riskier, as again, it is always better to have more biofiltration than needed to prevent catastrophic failures.

Volcanic gravel is a naturally occurring stone with a tremendous amount of surface area which makes it ideal to place in a biofiltration chamber. Conversely, sand does provide extremely high levels of surface area, but the grains are so small that they can permeate the system, leading to issues. The sand that remains in the biofilter also undergoes compaction, such that water is not able to filter through, rendering it useless.

Other, man-made options for bacterial homes are available, such as plastic bottle caps, which are large enough to not pass through the system but will allow water to filter through. Any sort of netting works, as does less conventional products such as nylon shower poufs, PVC shavings (which are slightly riskier as they compact more than intended), and nylon scrub pads. There are even commercial products which can be used, such as bio-balls, which are small plastic spheres (approximately 1 cm in diameter or less) with holes or protrusions formed so as to provide increased surface area. Any other objects which provide high amounts of surface area, do not compact down readily, and do not break down quickly could function as a filler material for the biofilter.

Many methods are being designed to accomplish the tasks necessary to sustain an aquaponics system. As long as the task is completed, it does not matter what other tasks it is combined with, nor in what manner is it performed. While aquaponics may still be a more “backyard science” field of study performed with less rigor than academia, the creativity of the

public at large all working together is what makes aquaponics unique, and designing new methods of accomplishing these tasks is where that advantage is allowed to shine. In conjunction with this more widespread system design, academic institutions have begun performing research on various aspects of aquaponics systems, allowing for more rigorous testing of these designs.

2.8 Example of Sustained Aquaponics System – University of Virgin Islands

An example of how these concepts all work together to produce a functioning aquaponics system can be seen in a system used at the University of the Virgin Islands. There is an outdoor system, and they had much more land area to expand outward, taking up 500 square meters of land [17]. An outdoor system is possible as well since their system was built in a warmer climate. A diagram of their facility is shown below.

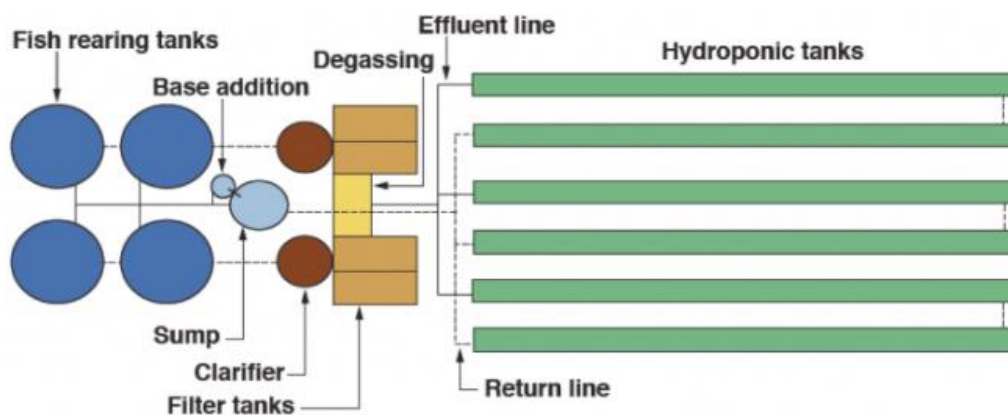

Figure 1. The layout of the University of the Virgin Island's aquaponics system [22]

The system at the University of the Virgin Islands houses the fish in four large rearing tanks, separated into groups of two [17]. Each set of two tanks then feeds a single cylindroconical clarifying tank [17]. Each of these clarifying tanks then feeds into a series of two filter tanks, where biofiltration occurs, and the water from the filter tanks then feeds a single degassing tank, allowing the harmful gasses to escape [17]. Being a larger system, the degassing tank became more necessary. The degassing tank then feeds three of the six hydroponic, deep

water culture troughs, which house the plants [17]. Each of these three rows of plants then feeds a secondary hydroponic trough at the end opposite the degassing tank, allowing the water to flow back toward the fish [17]. The three secondary tanks then feed back into a central sump tank, which sends water back to the four rearing tanks [17]. The sump tank not only provides a location to test all the water in the system as all the clean water flows through it at some point, but it also allows any medication necessary to be given to all the fish at once. Two pumps are used in the circulation of this system, and they may be situated such that they draw the water out of the sump tank to send it to the rearing tanks [17]. Aeration occurs as the water enters back into the rearing tanks since the inlet is above the water's surface [17]. Airstones are also situated in the rearing tanks, and the plant troughs also help with aeration of the water, allowing a large area of flowing water to mix with the atmosphere [17].

3. Previous Literature

This model was taken from “Modelling an Aquaponic Ecosystem Using Ordinary Differential Equations” by Carly Bobak and Herb Kunze [1]. Any variables with a dot above them indicates a derivative of that variable with respect to time. The constant a_1 is associated with the birth rate of the fish in the system, a_2 is associated with the rate at which fish produce ammonia, a_3 is the amount of ammonia consumed each day by the bacteria, a_4 is the amount of nitrate produced by the bacteria consuming one unit of the ammonia, a_5 represents the nitrate uptake rate of the plants, and a_6 is tied to the growth rate of the plant population [23]. The model is as follows:

$$\dot{F} = a_1 \left(1 - \frac{F}{K_F}\right) F - \frac{A}{K_A} F \quad (3)$$

$$\dot{A} = a_2F - a_3A \quad (4)$$

$$\dot{N} = a_4A - a_5NP \quad (5)$$

$$\dot{P} = a_6 \left(1 - \frac{P}{K_P}\right) PN \quad (6)$$

The coefficients presented in the paper are as follows: $a_1 = 0.0124$, $a_2 = 0.1$, $a_3 = 0.94$, $a_4 = 3.6$, $a_5 = 0.92$, $a_6 = 0.056$, $K_A = 20$, $K_P = 300$, and $K_F = 250$, and initially, $F = 10$, $A = N = 0$, and $P = 0.5$ [1]. The coefficients were based upon physical laws and experimentation, as cited in their previous research, and each of the a coefficient terms also represent various percentages from previous research [1, 23].

The a_1 term was calculated based on a study done by Bhujel, Little, and Hossain involving fifteen tilapia, and tracked the number of fingerlings spawned, as well as how many survived [23]. The a_2 term was selected from a range of values to best match the expected growth rate of the populations, and this value was explained using crude protein content in the feed and approximate average fish weight [23]. The value of a_3 was also roughly approximated, estimating that 94% of the ammonia in a system is converted to nitrates each day [23]. The a_4 value was chosen based on stoichiometry, using the molar mass of ammonia and nitrate to conclude that “1 ppm of ammonia equates to 3.6 ppm of nitrate”, though it seems the value of a_4 was altered slightly from their previous research’s value of 3.384 [1, 21]. This seems to be due to removing the dependence on the 94% from the a_3 term ($3.6 * 0.94 = 3.384$), as this percentage does not affect the stoichiometric equation [1, 21]. a_5 is highly variable as well, since “the nitrate uptake rate of plants has been estimated to be between 86% and 98% of available nitrate in aquaponics environments” and these two values were averaged to reach the given rate of $a_5 = 0.92$ [23]. The a_6 term’s value was based on a previous study done by Liang and Chiens who

quantified plants at growing an average of 5.56% per day, leading to the term's value of 0.056 [23]. K_F was calculated using a stocking density for tilapia of 25 liters (6.6 gallons) per fish and an arbitrary tank size of 10 liters (2.64 gallons) [23]. The K_A value in their research assumed 2 ppm was the lethal limit for all fish, which seems reasonable as this was the value that killed all the tilapia tested within 24 hours in another study [22, 4]. This value of 2 ppm was then multiplied by the arbitrary tank size of 10 liters (2.64 gallons) to calculate K_A [1, 21]. While these numbers may make mathematical sense, 10 liters seems like very little water for the system [23]. The report also assumed that thirty lettuce plants could grow in each square meter based on previous research, and an arbitrary grow bed area size of 10 m² was selected, yielding a product of $K_P = 300$ [1, 21].

This model was solved iteratively by calculating the derivatives of F, A, N, and P, and this value was then multiplied by the time step and added to the previous value. The graphs created by these models were compared to the graphs provided in the previous research to ensure the model was recreated successfully.

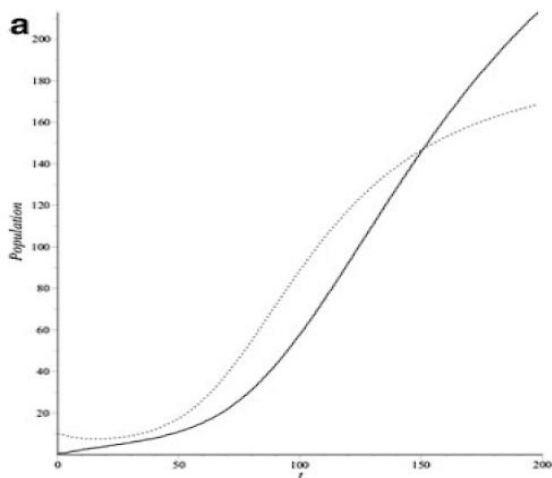

Figure 2. The original plot of the fish and plant population [1]

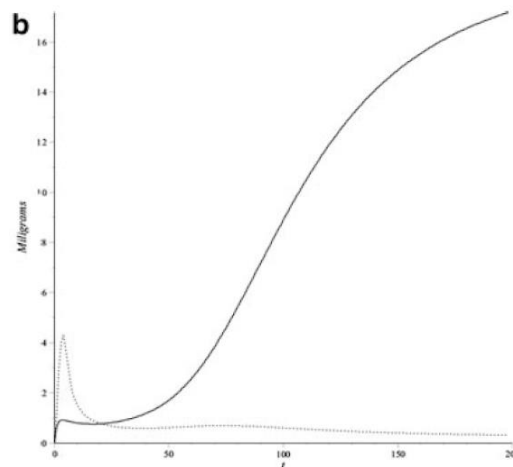

Figure 3. The original plot of the ammonia and nitrate levels [1].

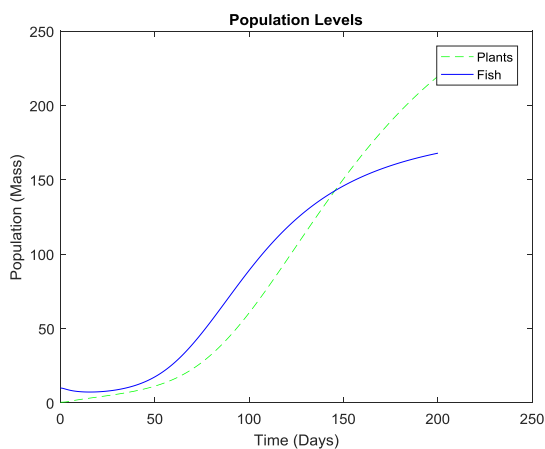

Figure 4. The plot of the fish population and the plant population for the given coefficients

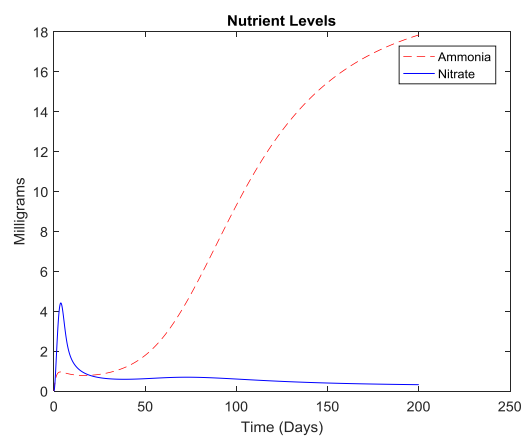

Figure 5. The plot of the ammonia and nitrate levels present in the water

These figures match approximately to those given in the paper, which means it appears the system was recreated correctly [1]. Due to all of the values starting at approximately zero, it is readily apparent that the system of equations, as given, represents a start-up aquaponic system.

The purpose of this investigation was to examine if these equations could be used to model an existing, physical system. To that end, the a_2 term was selected for further refinement

due to the previous research being very inexact. Therefore, experiments were designed to more accurately predict this value for varying conditions experienced by fish in differing aquaponics systems to track the amount of ammonia they produced.

4. Experimental Design – Effects on a_2

In order to accomplish this task of identifying reasonable values for the production rate of ammonia, the a_2 term, a series of experiments were designed. The value for this coefficient estimated from these tests would allow a more accurate model to be produced. Using this, a farmer would have a better idea of the chemical operational equilibrium points of their system.

To that end, the fish would be separated out, one to each tank. Each tank would have a different combination of varied factors discussed in this section, and a single round of trials would be performed each day. A single fish would be used in each tank to remove other variables, such as food competition, even though fish compete naturally for food in an operational aquaponics system. Each tank would begin each trial with clean water which had been dechlorinated using a commercially available dechlorinator, and the water would also have another chemical added which reduced stress to the fish and helped retain the necessary slime coat on their gills. The trials would then consist of feeding each fish the designated amount, then tracking the amount of ammonia they produce over a 12 hour period.

There are many factors which affect the ammonia production rate, most notably the amount of feed given to the fish. If the fish are given more feed, it was assumed it must pass through their systems, generating more ammonia than if they had been given a normal amount. The other factors evaluated are the tank size (used to simulate varying stocking densities), the light level, and the amount of protein present in the food. It is expected the effects of the protein

level will closely follow the effects of the amount of feed provided, and a general trend of the effects of the other variables was known from the literature, but any numerical effects the changes would have were not present.

The feeding of the fish in an aquaponics system is typically based on the preference of the farmer, though once a day is acceptable [24]. This experiment, on the other hand, focuses more on the hourly changes of the chemical levels as opposed to the daily levels. Therefore, only one feeding is used per test, and the effects of that feeding are measured by tracking the ammonia level of the water over time for 12 hours.

These experiments were originally going to be performed on feeder goldfish due to their availability. While goldfish are not widely consumed, they have been used in aquaponics systems “with good results” [25]. Unfortunately, a single fish could raise the ammonia in the testing containers noticeably, resulting in their data being useless to track the hourly fluctuations of the ammonia level. Initially, these goldfish were going to be placed in much larger tanks, and a single trial was performed. It was then realized that this was simulating a stocking density closer to 60 to 100 gallons per pound of fish, and to get down to a stocking density of two gallons per pound, or even ten gallons per pound, removing the water to test the ammonia would significantly affect the water level remaining, and therefore, the concentration of ammonia in the following tests. In addition to this, the shallow water level may also be hazardous to the fish. As a final test, five goldfish were placed in approximately six gallons of water and fed a significant amount of high protein goldfish feed two times per day. Even under these ideal circumstances, no noticeable change in the ammonia level could be measured after 2 days, so it was decided to switch to tilapia.

Tilapia are commonly used in aquaponics due to their resilience to poor water conditions [26]. They also are large enough that removing 5 milliliters of water for each of the ammonia tests would not significantly affect the desired simulated stocking density for the test. The testing was then performed using the original intent of placing 1 fish in each of the testing containers to eliminate competition and other unknown variables.

4.1 Feed Amount Variations

A single, one pound fish is generally fed approximately 0.16 ounces of food each day, as this is approximately 1% of their body weight, which is less than the recommended 3% of their body weight as a precaution against the ammonia rising too quickly [27]. The lower feeding amount was selected to attempt to limit the production of ammonia, leading to a higher resolution on the data. Three variations were selected for this experiment, the normal amount of food, or 0.16 ounces, half of the normal amount of food, or 0.08 ounces, and 1.5 times the normal amount of food, or 0.24 ounces. These options were chosen to simulate differing real-world scenarios simultaneously and to provide a wide spectrum of effects for analysis. For instance, feeding half the recommended amount of food is used to simulate severely underfeeding and the 1.5 times is to simulate feeding closer to the recommended 3% [27]. To avoid any actual harm coming to the fish, the fish would be underfed or overfed for at most two days. It is a common practice when harvesting fish to withhold feed for four days to ensure all waste is out of their system, so two days would not harm them [28]. To ensure that the proper amount would be given to each fish, the food was measured out using a scale.

The high and low values were chosen not as goals to shoot for, but as endpoints to a spectrum. They were intended to yield results on the outer edges so interpolation could be used to find the effect on the a_2 term correlating to the amount of feed selected by the farmer. Varying

the amount of food given may yield differing results, such as possibly increasing growth, and various sources give conflicting values as to the amount of feed that should be provided each day, which is the cause for attempting to identify a spectrum of values.

4.2 Feed Protein Level Variations

The amount of protein present in the feed was varied as well to find the most extreme reasonable values. The results from altering the protein level in the feed could then be used to interpolate the effect of the protein level of the farmer's selected feed so that as many possible cases could be covered. To that end, two protein levels were selected, with 30% of the feed being crude protein being the low end of the spectrum, and 43% being the high end, chosen due to their ready availability at pet stores. Other values of protein levels would have been chosen as well, but options were limited as the intent was to use commercially available feeds, much like an aquaponics farmer would.

4.3 Simulated Stocking Density Variations

Another factor varied in the design of the experiment was the amount of water used in the test. Three levels were selected for this due to the wide range of stocking densities various sources claim are reasonable, from two gallons per pound of fish up to eight gallons per pound [9]. To that end, the three sizes selected were three gallons per pound of fish, five gallons per pound, and seven gallons per pound.

While some companies do run their stocking densities even lower than three gallons per pound, it seemed advisable to keep more water in the containers so as to not begin running into issues with the water removed for ammonia testing significantly impacting the simulated stocking density and to allow the test to run for longer [8]. With multiple fish in a single trial,

this would not be an issue as there would be more water present, but as stated earlier, it was decided that a single fish would be placed in each container to eliminate any variations due to the interactions between the fish. Other companies may run their stocking densities higher than seven gallons per pound of fish, but it was assumed that most would try to do so as to pack more fish in and generate a larger profit in less space.

4.4 Light Level Variations

The final variable altered in these experiments is the amount of light the fish are exposed to while the test is being performed, due to previous literature which states that fish prefer low light levels [10]. In accordance with this, a medium and a low light level were selected for the experiments to avoid the extreme brightness and complete darkness which the fish do not like, and to attempt to approximate situations farmers would realistically [10].

The medium-light level corresponds to fish kept in opaque containers which are mostly closed on top, but near the bright grow lights or are completely open on top, but further from the grow lights in an aquaponics system. For a rough approximation of the amount of light present in these real-life scenarios, opaque black totes were used, and a clear lid was placed on top so as to allow the lights from the room to shine in. The room lights are fluorescent lights approximately 15 feet above the top of the tank and interspersed throughout a large area. While this does yield a light level slightly higher than the medium-light levels present in some farming operation, it will provide a wider range of values to extrapolate between.

A low-light level is meant to simulate fish being kept in a darker area, possibly on a separate floor away from the plants grow lights or in opaque tanks further away from the bright grow lights. Opaque black totes were used to simulate this in the experiments, and opaque black

lids were mostly replaced so that the inside of the tank was very dark. As stated earlier, a bright light level such as shining lamps directly on the fish or a pitch dark light level such as completely covering the container were not tested due to these options being far from ideal for the fish and therefore, not recommended for aquaponics farming. The results from these tests could be extrapolated out to examine the effects those extreme light levels would have on the fish, but it is unknown how closely the results would match reality.

5. Experimental Testing Procedure - Effects on a_2

Thirty trials were to be performed each day until every combination had been tested once (which would have taken two days, as thirty tilapia were used for 36 different combinations). The tests themselves were fairly simple and straightforward to accomplish. Each round of trials consists of placing one fish in each of thirty totes with the water level calibrated to their approximate weight to simulate the desired stocking density. Once the fish had been placed, they were each to be fed the appropriate amount of food based on the desired feeding amount being tested. The ammonia in the container was then tested every half hour until 12 hours had elapsed. Once this trial was completed, the fish were all to be transferred to the IBC they arrived in while the next round of trials could be prepared.

Water was constantly aerated during the trials through the use of a single airstone in each of the small containers with the fish, with multiple pumps used to each aerate a sub-group of the containers to yield sufficient oxygenation. The ammonia testing was performed using commonly available liquid ammonia tests where five milliliters were removed for sampling. Chemicals were added to the sample to measure the ammonia levels; then the mixture was dumped out and not added back to the fish tank so as to not introduce any potentially harmful chemicals into the

fish's habitat. The airstones used were small, a cylinder approximately an inch long and half an inch in diameter and these were fed air by a commonly available aquarium air pump through pneumatic tubing.

6. Results – Effects on a₂

The results of these tests were inconclusive. It was discovered through attempting to begin the tests that the fish would not consume the food offered unless they were content, as most of the fish ate nothing, while a few ate only a couple pellets. Therefore, they were given fresh water and left to become acclimated to their testing environments overnight. When the trials were about to begin the following morning, the ammonia was tested in each tank to find a base level for each individual test. It was then that it was discovered that the amount of ammonia each fish produces is much too varied to yield any reliable results, even without any modifications to their food or tanks. Fish in identical conditions (identical light levels and identical water amounts as they did not eat) would have wildly different amounts of ammonia present in the tank before the test began, some already up to a dangerous level before testing.

When the fish were placed into their respective tanks with clean water free of ammonia and left overnight (approximately 10 hours) to settle into their environments, many of the tanks showed 4 ppm already, though some showed less. As the water was already at a dangerous ammonia concentration for many of the fish, no tests were performed, and the water was replaced with clean water, and the fish were left overnight again (approximately 20 hours this time). Upon checking the ammonia the following morning, identical results were found with some testing containers already measuring 4 ppm before testing began. Due to this, it was

determined that these tests would not work in their intended configuration. Therefore, the initial value of the a_2 term given in the previous literature section as $a_2 = 0.1$ is still the best estimate.

One result of significance is that, while attempting to allow the fish to settle into their testing environments, it was discovered the fish continued to produce waste, even after they had not been fed for two days. This shows the feeding of the fish would not produce an effect on the ammonia level in the system in a matter of hours. The timescale would be more likely on the order of days before the effects of any overfeeding or underfeeding were noticed. Therefore, in scaling up the testing, the fish would need to be placed in clean water, and the different batches of fish must be overfed or underfed with their respective various protein level foods for days to notice a result in the ammonia level. Further testing would be required to verify the time scale.

The focus of the project was then shifted to two separate directions. The first focus was on deceased fish. Some fish had died of natural causes whether that be stress during shipping, jumping from the testing containers overnight when no one was around to place them back in their tanks, or some other cause. With these dead fish it was decided to test the effects they would have on the ammonia level in any sort of aquatic habitat, as it was theorized that they would produce high levels of ammonia and effectively poison any other fish.

The other focus became tracking the ammonia produced by the fish in the IBC they were shipped in. The battery of tests varying the different factors was not run on the single IBC due to the stress to minimize stress to the fish as the testing had already resulted in many of their deaths.

As the experiments were unsuccessful in their current form, it was theorized that they could be applied to larger tanks of fish for each trial, thereby eliminating much of the variation from fish to fish. Though the various factors could be tested using larger groups of fish, a wider

range of possibilities for each factor could be chosen to give a better representation of numerical effect on a_2 .

7. Experimental Design - Deceased Fish

There were intended to be two separate types of deceased fish used in these tests: fish which had been dead 4 days and had been kept in individual tanks of water since then, and fish which had been dead a mere 0.5 days. This would provide insight into the amount of ammonia a fish produced when newly dead as well as when they had not been removed for a few days after death, which simulated conditions found in a poorly kept aquaponics system. Each fish was to be kept in five gallons of water to simulate a stocking density of five gallons per pound of fish, as this seemed to be a commonly used value from previous research. No food would be introduced, as deceased fish do not eat, and uneaten food raises the ammonia level and therefore is a separate issue not being tested in these trials. The tanks would also each have an airstone which would supply more than enough oxygen to the water to better simulate the fish being deceased in a well-oxygenated tank as would be the case if they died in the normal fish habitats. The fish would also all be kept in opaque containers with opaque lids mostly replaced to again better simulate the ideal housing conditions for the whole fish population as they would be found in a real aquaponics system. The tests would be performed for 6 hours with samples taken every half hour so as to provide a better idea of the amount of ammonia produced by each fish each hour.

8. Testing Results - Deceased Fish

The ammonia alone was tracked due to preliminary testing of the water the fish had been dead in for 4 days yielding no signs of nitrite, which matches intuition since the bacteria which

would convert the ammonia to nitrite were not present aside from any minuscule amounts that may have been carried over on the fish's skin. The results are given below in Table 1.

Table 1. Results of the Deceased Fish Testing in ppm

Time	Fish 1 – Dead 4 Days	Fish 2 – Dead 4 Days	Fish 3 – Dead ½ Day
0	0	0	0
0.5	0	0	0
1	0	0	0
1.5	0.5	0.35	0
2	0.5	0.4	0
2.5	0.5	0.5	0
3	0.5	0.5	0
3.5	1	1	0.25
4	1	1	0.25
4.5	1.5	1	0.25
5	1.5	1.5	0.25
5.5	2	2	0.25
6	2	2	0.25

The results of these trials were graphed and shown below in Figure 6.

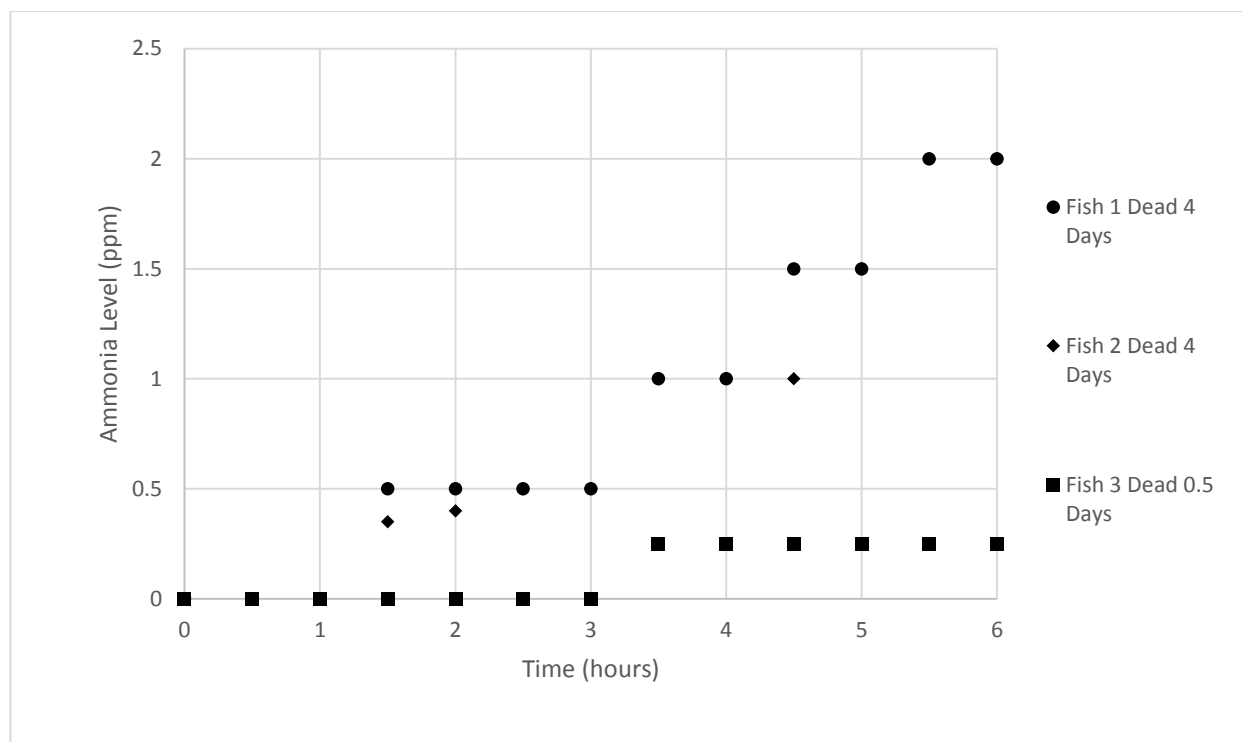

Figure 6. Plot of the Ammonia Data from the Deceased Testing

From the plot, there are a few key points readily apparent. The data shows a gradually increasing trend, which is what would be expected. The fish will produce ammonia, and there are no bacteria present to consume said ammonia since the tests were performed in newly cleaned tanks. Secondly, the stair-step like nature of the data is a product of the testing. To measure the ammonia level, 5 milliliters of water was sampled and placed in a vial; then chemicals are added which turn the mixture a shade of green. This shade must then be compared to the chart given to determine the concentration of ammonia in the system. As this is not an exact measure, the data is an approximation of the true ammonia level. The commercially available ammonia testing kit was used so that the tests could be repeated by aquaponics farmers in general to verify results or to be used in the previous tests described to find a better approximation of the a_2 term.

The seven-gallon tanks which held a single deceased fish each for four days had been tested as well, and Fish 1's ammonia level was found to be 6 ppm while Fish 2's ammonia level was found to be 4 ppm. Both of these levels are extremely high and toxic to other fish, but it did take 4 days to reach those levels. Both of the fish which had been dead 4 days consistently produced more ammonia and at a faster rate than the one which had been dead only 0.5 days. The fish which had been dead longer seemed to produce ammonia at approximately 1/3 ppm per hour in a five-gallon tank, or 6.309 milligrams per hour. One ppm is the same thing as 1 milligram per liter or 3.785 milligrams per gallon. Multiply this by 5 gallons since that was the size of the testing container, and divide it by 3 as the dead fish reach 1 ppm in approximately 3 hours to get the 6.309 milligrams per hour. This mathematical process is shown below in Equation 7.

$$\frac{3.785 \frac{mg}{gal} \times 5 gal}{3 hours} = 6.309 \frac{mg}{hr} \quad (7)$$

This rate can be compared to the newly dead fish, which seem to produce a mere 0.25 ppm in 6 hours, or 0.830 milligrams per hour. While in the context of a large tank which holds the entire fish population, both of these values are insignificant. It is readily apparent that the longer the fish are left to decompose in the holding tank, the worse it will be for the system. This does not take into account the other chemicals produced by the decomposing fish corpse, nor what effect they would have on the rest of the system. The water in the tank also does not mix evenly, so the concentrations of ammonia would be higher near the corpses.

Overall, the dead fish seem to have less of an effect than expected on the ammonia level in the tank. It is still recommended that the decomposing fish be removed to prevent the smell as

well to prevent the spread of any diseases that may have killed the fish or any other chemicals the corpse releases.

9. Experimental Design – Multiple Fish

The ammonia in the large IBC was tested once all the remaining fish were returned to it from their individual containers. The IBC was mostly emptied, retaining just enough water to allow the fish to survive. It was then refilled with water to which was added dechlorinator to make the water safe for the fish. The pH of the tank, once it was full, was tested to ensure it was at the proper level (approximately 7.8). Then the ammonia, nitrite, and nitrate levels in the IBC were tested every half hour as often as was possible. The biofilter was removed so as to allow the ammonia the fish produced to rise as naturally as possible. Some bacteria would still be present on the walls of the IBC, but by removing the biofilter, the majority of the nitrifying bacteria were stopped from having an effect on the system. The test was run until the ammonia level reached a dangerous 4 ppm, a process which normally had taken approximately 12 hours from previous experience. Approximately 20 fish were present in the IBC.

10. Testing Results – Multiple Fish

The testing ended up taking 11 hours for the IBC to reach 4 ppm from the 0.5 ppm which was as low as it was gotten by replacing out most of the old water with fresh water. As it was such a long trial, there are some gaps in data due to previous commitments. These gaps seem to be inconsequential as the ammonia seems to have been increasing at a fairly steady rate. The nitrate level at the start of the testing was not found as it was not originally going to be tracked, but it was realized once the testing had begun that it might yield intriguing results. The data of this testing are given below in Table 2, then plotted in Figures 7 and 8.

Table 2. Results of the IBC Ammonia Level Testing

Time (hours)	Ammonia (ppm)	Nitrite (ppm)	Nitrate (ppm)
0	0.5	0.5	
1.5	0.75	0.75	15
3.5	1	0.75	20
4	1	0.75	20
4.5	1.25	0.75	20
5	1	0.85	20
5.5	1.25	1	25
7		1	25
7.5	1.5	1	25
8		1	20
8.5	2	1	25
9	2	1	30
9.5	2.5	1	25
10	2.5	1.25	30
10.5	3	1.5	30
11	4	1	35

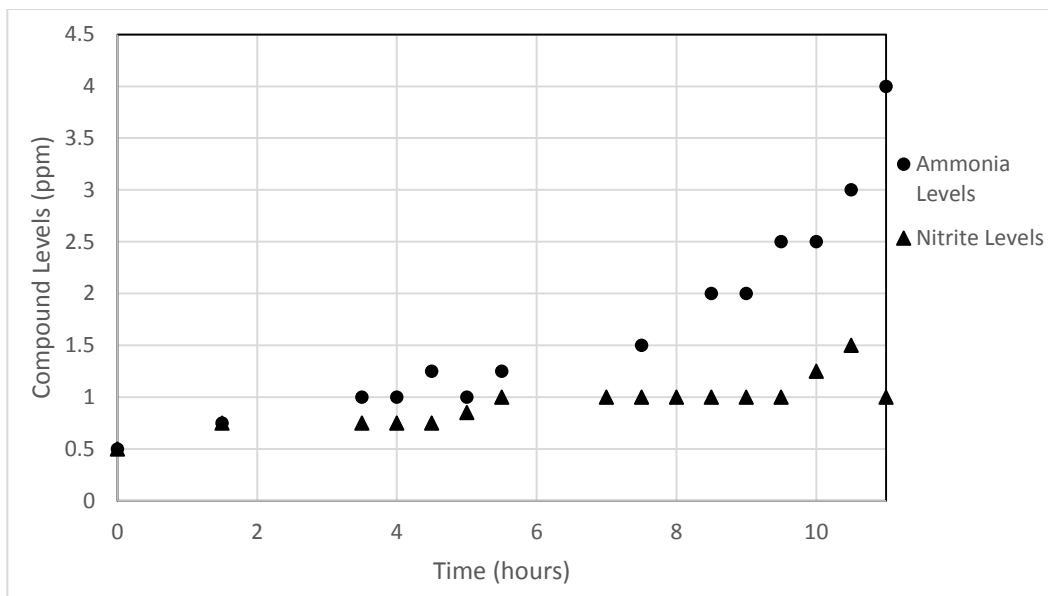

Figure 7. Plot of the Ammonia and Nitrite Levels for the IBC Testing in ppm

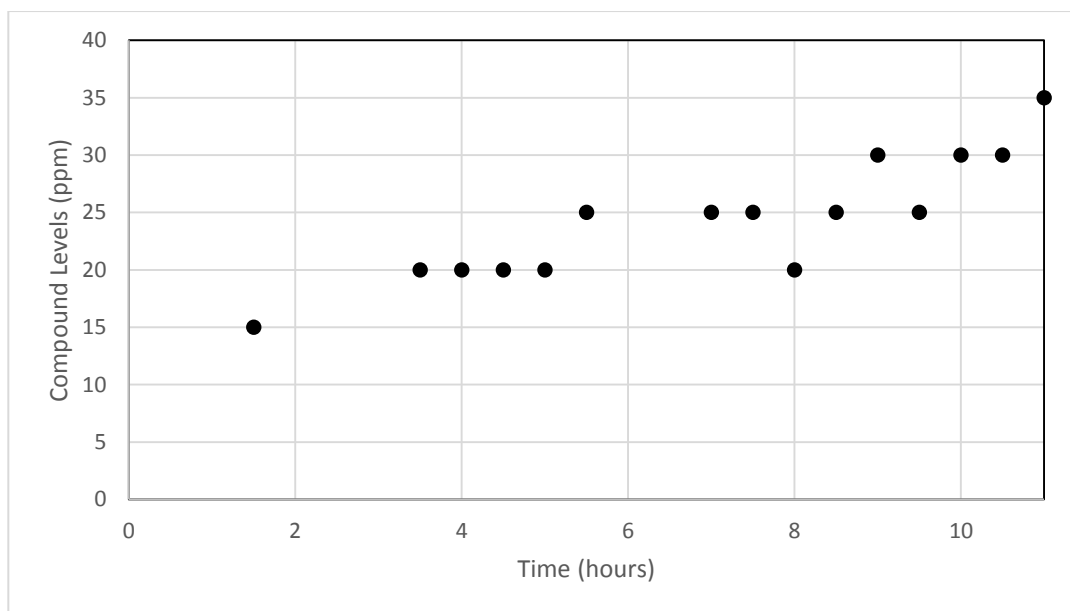

Figure 8. Plot of the Nitrate Data from the IBC Testing in ppm

The two blank entries in the ammonia column were due to a very clear malfunction which yielded unreliable results for those entries. The malfunction was corrected both times.

The stair-step like quality of the data again comes from the inexact nature of gauging the amount of a compound in the water. All three tests, one for each compound, involved comparing the color the sample turns to a chart. The nitrite and ammonia levels were plotted together since they are very close in values. The nitrate levels would have ideally been plotted with the other two sets of results, but the values were too far removed so that any trends in any of the data sets would have been masked.

The ammonia levels, for the most part, seem to increase nonlinearly as opposed to linearly like previously speculated. This is especially apparent near the end of the ammonia testing shown in Figure 7. It is unknown whether this is an actual phenomenon or whether this is due to the inexact nature of determining the level of the compound present due to the color. Further testing is required, but if this is a natural phenomenon, that would be logical since the increased ammonia would stress the fish more, and the increased stress would cause them to release more ammonia, creating a self-destructive cycle. The bacteria conversely could not multiply quickly enough or did not have enough surface area to combat this rise of ammonia. To extrapolate this data, the twenty tilapia produced approximately 3,331 milligrams of ammonia in the eleven hours, and to examine what effect that would have on another system, simply multiply this number by the number of liters present in the other system, which will yield the approximate ammonia ppm level present in the other system. It is unknown whether the nonlinear effect would occur in a larger system where the ammonia level did not begin approaching 2 ppm yet, so this estimation is inconclusive without further testing on various other sizes of tanks, as well as repeated trials with this size tank. If the exponential increase is a legitimate phenomenon, then it is assumed the increase in the ammonia levels of other tanks would begin to increase quickly once the ammonia level reached approximately 2 ppm.

The nitrite levels seem to increase slightly, then level off, and it is unknown why the level begins to plateau. The slight rise and dip around the five to six-hour mark either is due to the nature of the data comparison, or it may be a slight fluctuation in the level of various compounds, which is reasonable since biological systems fluctuate continuously. The nitrate level rises steadily as well with slight fluctuations, which matches intuition since the nitrate is formed from the nitrite, and the nitrite level becomes constant, meaning the excess nitrite is converted to nitrate, which is not consumed in this testing scenario.

11. Further Work

The tests to determine the amount of ammonia produced under various conditions must be modified in order to achieve reliable results. Fish must be grouped together in order to eliminate biases caused by each fish producing a different amount of ammonia without any environmental factors. It is unknown whether this increased stocking density will affect the results, nor is it known how many fish must be used in each trial to eliminate these biases. It is also unknown how long of a delay there would be before any effects of differing feed types or amounts would be apparent. Testing should also be done to increase the amount of feed given to the recommended 3% of the body mass per day, as well as past this level [27].

Testing can also be done to verify the other coefficients in the given model. The a_3 and a_5 coefficients especially appear to vary widely or to be inexact. It is hoped that once these other tests have been accomplished and accurate coefficients have been achieved, tests of the ammonia and nitrate levels in an entire established aquaponics system could be performed to verify the reliability of the model. Once the model has been verified, further tests could then be

performed introducing different disturbances to the model and to the physical system to track how well the model predicts these changes.

12. Conclusion

In designing an aquaponics system, creativity and ingenuity are key to finding innovative solutions to satisfy the requirements of the system. As long as a habitat is provided for both the plants and the aquatic creatures, and circulation, aeration, degasification, clarification, and biofiltration and are accomplished, the system has a good chance of succeeding.

These tests laid out in the experimental design section might yield results if the tests were modified to use multiple fish as opposed to one fish to eliminate the influence any individual fish has on the results. The tests must also be performed over many days as it is unknown how long the changes in feed take to appear. It is assumed the trends generated would be applicable to most fish farmed for consumption, so these results could be used as a general basis. It would be preferred though if the tests were performed by the individual farmer if they desire to model their specific system more accurately, as a specific value would be more helpful in case of an accident. The importance of a more accurate value becomes even greater if the ammonia produced by the fish increases nonlinearly as the data seems to suggest. Due to the lack of reliable data yielded by the testing of the individual fish, the assumption of $a_2 = 0.1$ still remains the best estimate.

While this preliminary testing does not indicate that large amounts of ammonia are produced by deceased fish, these results are inconclusive due to so few trials having been performed. It is not known what effect other chemicals released by their decomposing corpses

would have on the remaining fish. The decomposing fish also seem to begin producing more ammonia over time.

The results from the IBC testing are intriguing and merit further investigation to determine if the exponential uptick once the ammonia level reached approximately 2 ppm was due to the method of quantifying the value of the color or due to the fish becoming more stressed, or possibly some other reason. Further testing is also required, if the exponential quality of the data is valid, to determine how this phenomenon would relate to various other systems of differing sizes. Due to the possibility of the exponential increase, it is unknown if these values for the amount of ammonia produced over time by 20 tilapia would directly apply to other conditions, or if the exponential increase causes the data not to transfer correctly.

List of References

It is important to note that though some references are less credible, the information was cross-checked across multiple sources. The necessary inclusion of these sources was a result of aquaponics being a less academic and less formal field of study, as stated earlier in this report.

- [1] Bélair, Jacques, et al., editors. “Modelling an Aquaponic Ecosystem Using Ordinary Differential Equations.” *Mathematical and Computational Approaches in Advancing Modern Science and Engineering*, Springer, 2016, pp. 189–196.
- [2] Malone, Ronald. “Recirculating Aquaculture Tank Production Systems: A Review of Current Design Practice.” Southern Regional Aquaculture Center, Oct. 2013.
- [3] Bernstein, Sylvia. “Managing PH in Aquaponic Systems.” *Maximum Yield - Your Modern Growing Resource*, 22 July 2017, www.maximumyield.com/managing-ph-in-aquaponic-systems/2/1208.
- [4] Evans, Joyce J., et al. “Un-Ionized Ammonia Exposure in Nile Tilapia: Toxicity, Stress Response, and Susceptibility to *Streptococcus Agalactiae*.” *North American Journal of Aquaculture*, 2006.
- [5] Oram, Brian. “Dissolved Oxygen in a Stream May Vary from 0 Mg/l to 18 Mg/l. Readings above 18 Mg/l Are Physically Impossible.” *Pennsylvania Well Water Testing Private Wellowners Drinking Water Pennsylvania Ground Water Education Program*, www.water-research.net/index.php/dissolved-oxygen-in-water.
- [6] “Frequently Asked Questions on Nitrite.” *Practical Fishkeeping Magazine*, 13 June 2016, www.practicalfishkeeping.co.uk/features/articles/frequently-asked-questions-on-nitrite.

- [7] Burke, Heather L. “The Nitrogen Cycle: Achieving a Balanced Aquarium for Salmon Success.” Michigan State University, Aug. 2014.
- [8] United States, Congress, “Feed Conversion Ratio (FCR): How to Calculate It and How It Is Used.” Feed Conversion Ratio (FCR): How to Calculate It and How It Is Used. pdf.usaid.gov/pdf_docs/PA00K8MQ.pdf.
- [9] Brook, Russell. “What Is The Right Stocking Density Of Fish?” Welcome To HomeAquaponicsSystem.com, 20 Jan. 2018, homeaquaponicssystem.com/fish/right-stocking-density-fish/.
- [10] Somerville, Christopher, et al. Small-Scale Aquaponic Food Production: Integrated Fish and Plant Farming. Food and Agriculture Organization of the United Nations, 2014.
- [11] Schmidt, James C., et al. “Requirements for Plant Growth.” Requirements for Plant Growth, Hydroponics as a Hobby, www.aces.uiuc.edu/vista/html_pubs/hydro/require.html.
- [12] “Green Plants & Chlorophyll.” Causes of Color, www.webexhibits.org/causesofcolor/7A.html.
- [13] “Plant Nutrients in the Soil.” NSW Department of Primary Industries, 1 Jan. 1970, www.dpi.nsw.gov.au/agriculture/soils/improvement/plant-nutrients.
- [14] Mann, Tim. “Aeration, Air Pumps, Blowers, And Airstones.” Friendly Aquaponics, 29 Mar. 2017, www.friendlyaquaponics.com/2017/03/28/aeration-air-pumps-blowers-and-airstones/.

- [15] "Oxygen Cones: 'Breathing Air.'" www.waterco.us/waterco/brochures/aquaculture/oxygen-cone/qxygen-cones_zzb1503.pdf.
- [16] Gannon, Mike. "Does Your Pond Need A Shower?" Full Service Aquatics, 19 Mar. 2012, fullserviceaquatics.com/koi-pond/does-you-pond-need-a-shower/.
- [17] Rakocy, James, et al. "Design and Operation of the UVI Aquaponic System." University of the Virgin Islands.
- [18] "DIY Swirl Filter for Aquaponics." Ecofilms, 20 Aug. 2010, www.ecofilms.com.au/diy-swirl-filter-for-aquaponics/.
- [19] Greeley, Melanie. Nitrite Toxicosis In Freshwater Fish: "Brown Blood Disease". Edited by Tim Muench, Animal Disease Diagnostic Laboratory, 1998, www.addl.purdue.edu/newsletters/1998/spring/nitrate.shtml.
- [20] Ebeling, James M. "Biofiltration - Nitrification Design Overview." College of Agriculture and Life Sciences, University of Arizona.
- [21] United States, Congress, Office of Water, Office of Ground Water and Drinking Water. "Nitrification." Nitrification, 2002. www.epa.gov/sites/production/files/2015-09/documents/nitrification_1.pdf.
- [22] Beem, Marley. "Recirculating Aquaculture Tank Production Systems: Aquaponics- Integrating Fish and Plant Culture." Oklahoma Cooperative Extension Service, Oklahoma State University, factsheets.okstate.edu/documents/srac-454-recirculating-aquaculture-tank-production-systems-aquaponics-integrating-fish-and-plant-culture/.

- [23] Bobak, Carly. “The Development and Analysis of a System of Ordinary Differential Equations to Examine Long-Term Stability of an Aquaponic Environment.” University of Guelph, 15 Aug. 2016, atrium.lib.uoguelph.ca/xmlui/handle/10214/9902.
- [24] Campana, Steven E. “Feeding Periodicity and the Production of Daily Growth Increments in Otoliths of Steelhead Trout (*Salmo Gairdneri*) and Starry Flounder (*Platichthys Stellatus*).” *Canadian Journal of Zoology*, vol. 65, no. 6, 1983, pp. 1591–1597.
- [25] “Recommended Plants and Fish in Aquaponics • Nelson & Pade Aquaponics.” Nelson & Pade Aquaponics, aquaponics.com/recommended-plants-and-fish-in-aquaponics/.
- [26] Genello, Laura. “Why Tilapia? Species Selection at the CLF Aquaponics Project.” Center for a Livable Future, John Hopkins Center for a Livable Future, 8 Jan. 2015, livablefutureblog.com/2015/01/tilapia-species-selection-aquaponics.
- [27] Riche, Marty, and Donald Garling. “Feeding Tilapia in Intensive Recirculating Systems.” North Central Regional Aquaculture Center.
- [28] Webster, Carl D., editor. “Harvest, Handling, and Processing.” *Tilapia: Biology, Culture, and Nutrition*, by Chhorn Lim, Food Products Press, 2008, pp. 608.
- [29] “55 Gal. Blue Industrial Plastic Drum.” The Home Depot, 20 Feb. 2018, www.homedepot.com/p/55-Gal-Blue-Industrial-Plastic-Drum-PTH0933/205845768.
- [30] “IBC 1000 Litre, Plastic Pallet, Cover 225 Mm, UN Approved, 2’ Ball Valve, Viton Seal.” DENIOS, Environmental Health and Work Safety, www.denios.co.uk/shop/ibc-1000-litre-plastic-pallet-cover-225-mm-un-approved-2-ball-valve-viton-seal/.

- [31] “Stock Tanks - 300 Gal Stock Tank Blk.” Amazon, www.amazon.com/Stock-Tanks-300-stock-tank/dp/B007IAFA9G.
- [32] “Aquaponic Systems.” *Suburban Grow*, suburbangrow.weebly.com/aquaponics---ststems.html.
- [33] “How To Set Up Bubbles In A Tropical Fish Tank Aquarium.” Tropical Fish Site, www.tropicalfishsite.com/how-to-set-up-bubbles-in-a-tropical-fish-tank-aquarium/.
- [34] “WMT?s Oxygen Cones.” Water Management Technologies, Inc., www.w-m-t.com/products/wmts-oxygen-cones/.
- [35] Sanke, Manke. Good Water Guide Pt. 17. Koi Carp Magazine, www.mankysanke.co.uk/html/good_water_guide__pt_17.html.
- [36] Sam Pike. “Spray Bar Filter Outflow Planted Tank.” YouTube, YouTube, 29 Sept. 2013, www.youtube.com/watch?v=LO-SGQSo2Us.
- [37] Maulana, Wildan. “Filter : Salah Satu Komponen Penting Di Sistem Aquaponik.” Belajar Bareng Aquaponik, 26 Jan. 2015, blog.belajaraquaponik.org/2015/01/filter-salah-satu-komponen-penting-di-sistem-aquaponik.html.
- [38] Introduction to Wastewater Treatment. California State University Northridge, www.csun.edu/~vchsc006/356b/WW.html.
- [39] “Auger Screw.” Omkar Industries, www.omkarindustriesindia.co.in/auger-screw.html.
- [40] “DIY Swirl Filter for Aquaponics.” Ecofilms, 20 Aug. 2010, www.ecofilms.com.au/diy-swirl-filter-for-aquaponics/.

[41] “Bio-Balls Biological Media.” Doctors Foster and Smith,
www.drsfostersmith.com/product/prod_display.cfm?pcatid=14727.

Appendix A – Figures of Specification Solutions



Figure 9. An industrial 55-gallon drum [29]



Figure 10. A 275-gallon intermediate bulk container (IBC) [30]



Figure 11. A 300-gallon stock tank [31]



Figure 12. Plants growing through a Styrofoam sheet demonstrating deep water culture farming [10]



Figure 13. Plants grown using the nutrient film technique [32]



Figure 14. Plants growing in a media (or aggregate) grow bed [10]



Figure 15. An air stone accomplishing aeration and degasification [33]

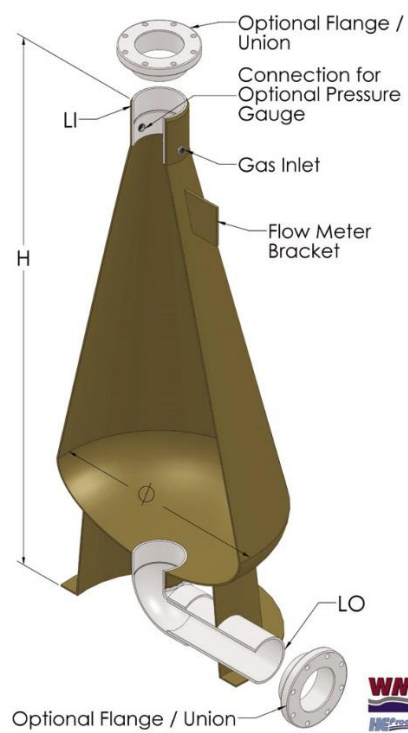

Figure 16. An oxygen saturation cone cross section [34]

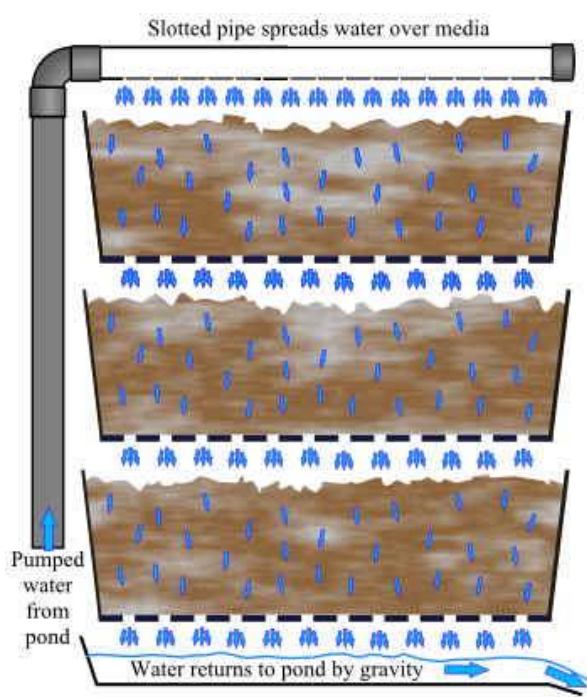

Figure 17. Diagram of a Bakki shower showing the inner workings [35]



Figure 18. A spray bar accomplishing aeration and degasification [36]

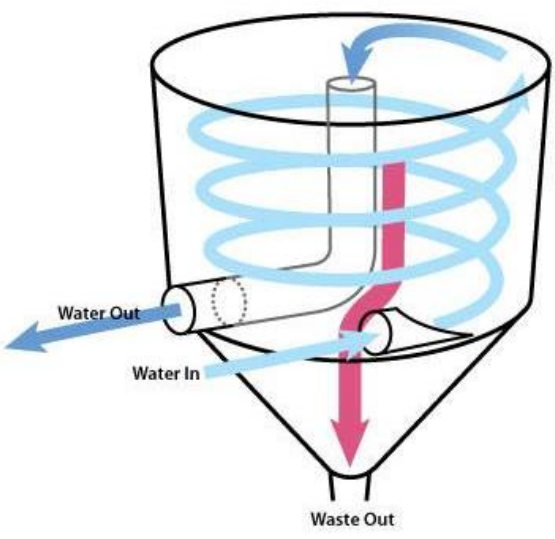

Figure 19. An example of a swirl filter, though many different configurations are usable [37]

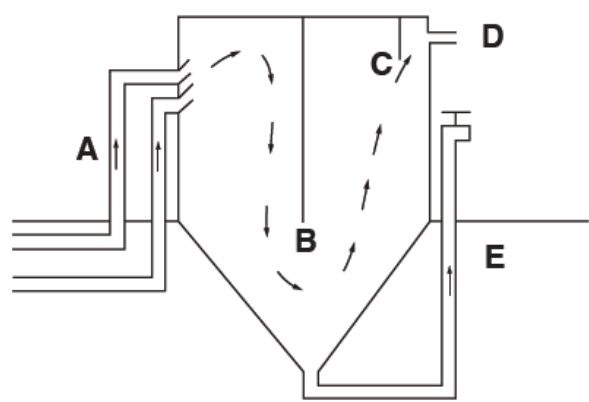

Figure 20. A baffle filter where the arrow's path demonstrates the water's flow and solids leave through the lower pipe [22]

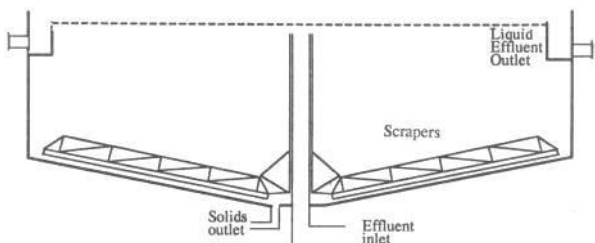

Figure 21. An example of one configuration of a settling tank [38]



Figure 22. An auger screw, which could be used for clarification by being placed in a pipe and rotated, acting as a baffle filter [39]



Figure 23. A simplistic drum filter, where water enters at the top and the water sent to the grow beds comes out through the center of the inner basket [40]

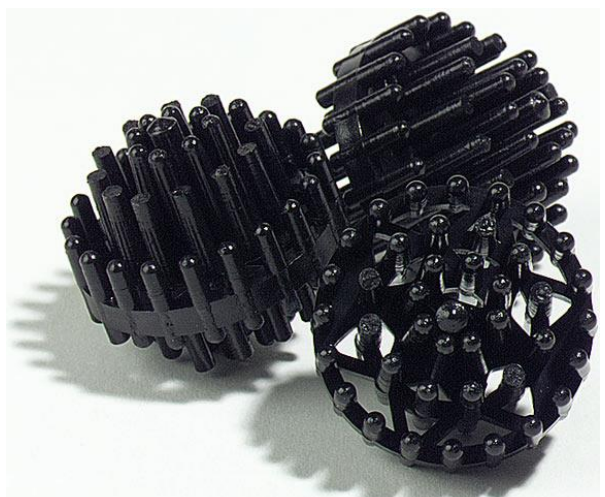

Figure 24. One type of bio-balls, though there are numerous other examples [41]