



## *Ducted Systems Technical Services Service Tips Letter*

Letter: **ST-002-2019**

Date: January 10, 2019

To: Ducted Systems (Factory Direct) S1 HVAC Branch Service, Sales, Warranty Managers  
Ducted Systems (UPG/Applied) Distribution Service, Sales, Warranty Managers

Subject: **Incorrect Polarity Fault – RED Fault Code 9 Flash**

Product: **LX Series Gas Residential Package Product Models: PCG, PHG.**

Summary: **This letter provides troubleshooting and repair information if package unit ignition control board indicates RED fault code 9.**

The purpose of this letter is to provide troubleshooting information, repair information, and general service tips if a RED Fault Code 9 should occur on one of the above-listed models. This letter applies to both single and three phase model equipment.

The ignition control board used in the single stage gas LX series package unit (PCG4), as well as the dual fuel heat pump / single stage gas backup (PHG4) LX series package unit, is powered by the unit 24VAC low voltage control transformer, but also has an L1 (line voltage) input. The L1 input is directed to an onboard switching relay and used to power the combustion blower motor. The L1 input is also used for flame sensing purposes. The ignition control board requires the low voltage transformer to be “in phase” with the line voltage input on the L1 control board connection. The L1 connection is a Molex plug that contains 3 wires. The 3 wires are labeled L1, IND, and FS. The low voltage wiring is connected to the ignition control board on a 6 pin header. The 6 pin header is labeled C, R, O, Y, W, and G.

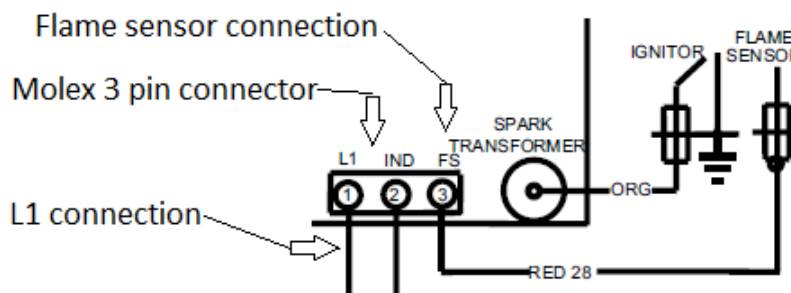

Single Stage Gas – Line Voltage Connections

The ignition control board used in the two-stage gas LX series package unit (PCG6), as well as the dual fuel heat pump/two-stage gas backup (PHG6) LX series package unit, is powered by the unit 24VAC low voltage control transformer, but also has an L1 (line voltage) input. The L1 input is directed to an onboard switching relay and used to power the 2-speed combustion blower motor. The L1 input is also used for flame sensing purposes. The ignition control board requires the low voltage transformer to be “in phase” with the line voltage input on the L1 control board connection. The L1 connection is a Molex plug that contains 4 wires. The Molex plug is labeled P2. The low voltage wiring is connected to the ignition control board on a 9 pin header. The 9 pin header is labeled C, R, O, Y1, Y2, W1, W2, G, and DEHUM.

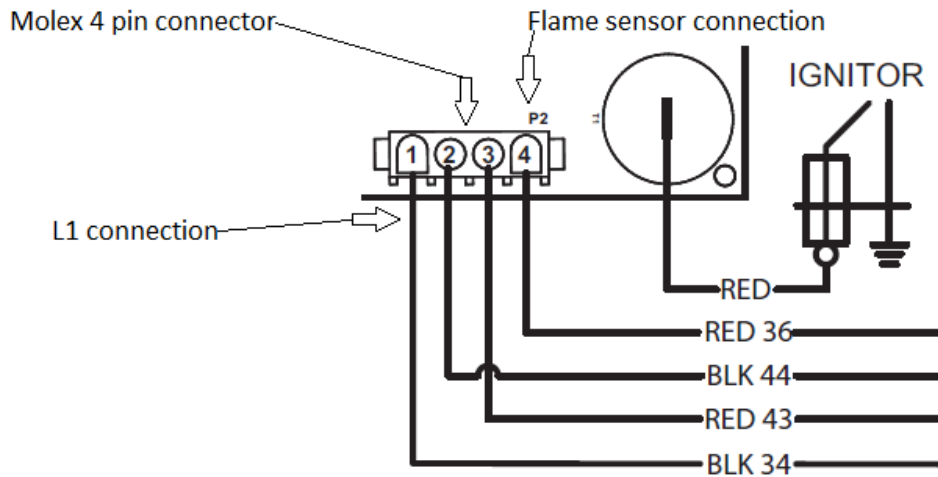

Two Stage Gas – Line Voltage Connections

In rare instances, a flame sensor may cause a Red fault code 9 indication. There are a few simple procedures that can be done to check the flame sensor circuit.

### SINGLE STAGE GAS MODELS:

Unplug the 3 wire L1-IND-FS Molex plug from the ignition control board. At the harness end of the Molex plug take an ohm reading from the RED wire to chassis ground. This reading should indicate an open circuit (O.L). If the circuit is not open check flame sensor wire for bad/severed insulation. The porcelain flame sensor insulator could be cracked, or on some occasions, a heat exchanger tube LoNox screen may have backed out of the tube and is making contact with the flame sensor.

### TWO-STAGE GAS MODELS:

Unplug the 4 wire P2 Molex plug from the ignition control board. At the harness end of the Molex plug take an ohm reading from the RED flame sensor wire to chassis ground. This reading should indicate an open circuit (O.L). If the circuit is not open check flame sensor wire for bad/severed insulation. The porcelain flame sensor insulator could be cracked, or on some occasions, a heat exchanger tube LoNOX screen may have backed out of the tube and is making contact with the flame sensor.

### CONTROL TRANSFORMER PHASING:

As described above, the 24VAC control transformer must be in “phase” with the L1 line voltage connection on the ignition control board. Since only L1 goes to the ignition control, the ignition control considers line voltage to be 120VAC. To check transformer phasing use a voltmeter and obtain a volts A/C reading from the Molex L1 connection to the low voltage thermostat “R” connection. If the control transformer is in phase the reading should be line voltage minus low voltage – approximately 96 volts. If the control transformer is out of phase the reading should be line voltage plus low voltage – approximately 144 volts. If the VAC reading indicates a control transformer out of phase, simply reverse the low voltage wiring at the low voltage control transformer. An image of the transformer connections to be reversed is shown below.

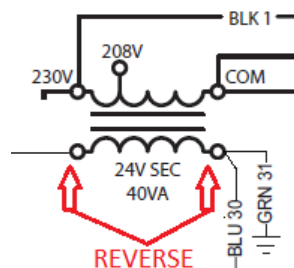

One side of the 24VAC low voltage control transformer is bonded to chassis ground. This GREEN wire connection uses a piggy-back type terminal with the BLUE wire. If the 24VAC control voltage wires must be reversed to correct an out of phase condition, move the GREEN wire with the BLUE wire. The GREEN and BLUE wires should be kept together regardless of what low voltage side of the transformer they are connected to.

Once transformer low voltage control wires have been swapped, apply power to equipment and re-check for proper transformer phasing. If RED fault code 9 is still present, disconnect power from the unit. Remove and swap the incoming field supplied and installed LINE voltage wires connected to the equipment L1 and L2 connections on the equipment contactor. An image of single phase equipment LINE connections are shown below.

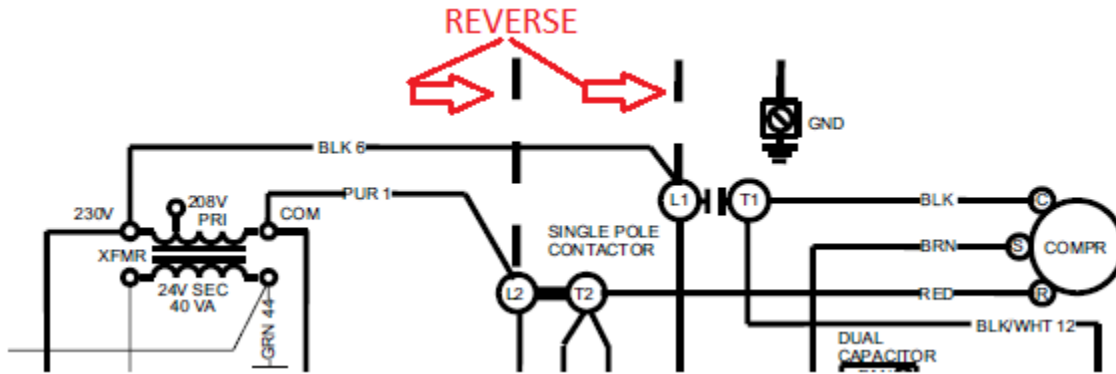

The same correction indicated in the paragraph above also applies to three-phase model units regardless of 208-230 VAC or 460 VAC incoming power supply voltage. An image of three-phase equipment LINE connections is shown below.

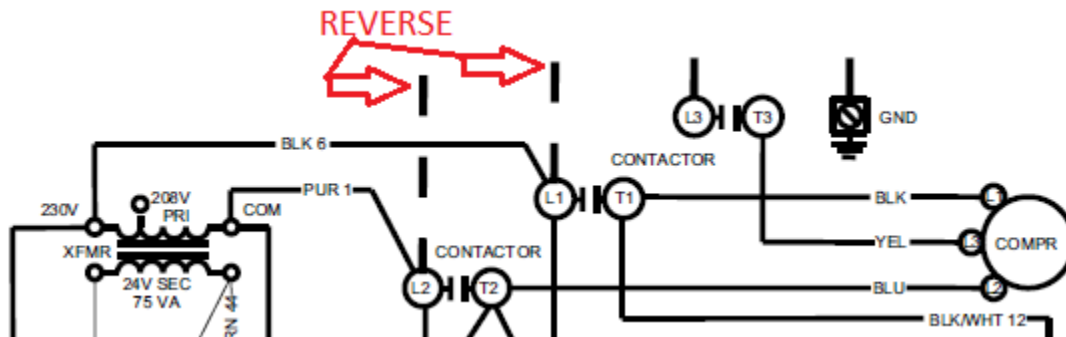

Once L1 and L2 incoming LINE voltage power wires have been swapped, apply power to equipment and re-check for proper transformer phasing. If the transformer phasing is now **incorrect**, disconnect power and reverse 24VAC control voltage transformer wires once again. Re-apply power and check for correct transformer phasing. If phasing is correct and RED fault code 9 is still present, disconnect power from the unit. Remove and swap the incoming field supplied and installed LINE voltage wires connected to the equipment L1 and L3 connections on the equipment contactor. An image of three-phase equipment LINE connections is shown below.

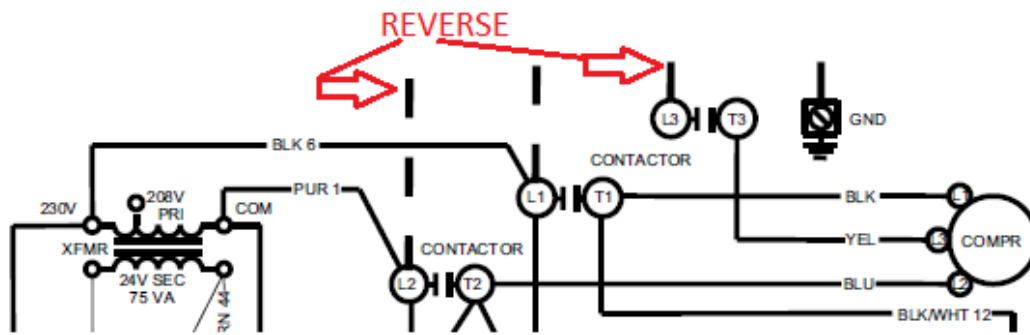

Once L1 an L3 incoming LINE voltage power wires have been swapped, apply power to equipment and re-check for proper transformer phasing. If the transformer phasing is now **incorrect**, disconnect power and reverse 24VAC control voltage transformer wires once again. Re-apply power and check for correct transformer phasing.

If control voltage transformer is in phase with line voltage, flame sense circuit is open to ground, equipment has proper grounding, and above corrections have been attempted, DSI (direct spark ignition) control board must be replaced.

**⚠ CAUTION**

*Scroll compressors require proper rotation to operate properly. Failure to check and correct rotation may result in property damage.*

If the equipment is three phase and contains a Scroll compressor proper compressor rotation **MUST** be confirmed. Three phase scroll compressors operate in only one direction properly. If the scroll compressor is drawing low current, has similar suction and discharge pressures and/or is producing a high noise level, the scroll compressor motor may be experiencing out of phase rotation and **MUST** be corrected or damage will quickly occur. To reverse compressor motor rotation, remove two of the compressor harness leads connected to the LOAD side of the equipment contactor and reverse them as shown in the example below.

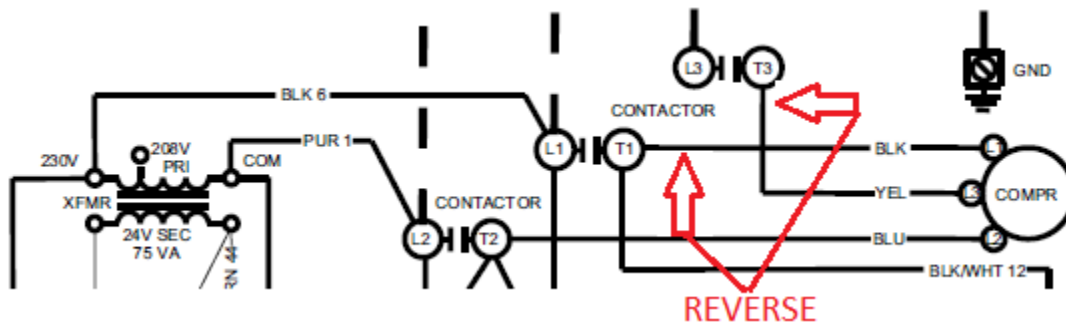

If you have any questions on this feel free to call Factory Direct Northeast Technical Services at 1-855-251-8267 and speak with a technical support representative.

Regards,  
 Thomas Hoffmaster II  
 York Factory Direct Northeast  
 Area Service Manager