



***Ducted Systems
Technical Services
Service Tips Letter***

Letter: **ST-014-2018**

Date: **November 12, 2018**

To: Ducted Systems (Factory Direct) S1 HVAC Branch Service, Sales, Warranty Managers
Ducted Systems (UPG/Applied) Distribution Service, Sales, Warranty Managers

Subject: **3-12 ton Packaged Reheat – Resolution of 3-way valve issue.**

Product: **Series 10, Predator, Outfitter, Ovation, ReliaCore 300, OmniCore 300**

Effective: **November 12, 2018** Expires: **November 12, 2021**

Summary: **This “Service Tips” letter provides modification instructions where units are found to have a 3-way valve malfunction in the reheat mode of operation.**

In late summer and early fall of 2018, Technical Services received isolated reports that the 3-way valve on the subject units was not actuating fully to the reheat position. If this occurs hot gas from the compressor during reheat mode will be fed to both the reheat coil and the condenser coil and the condenser coil bleed solenoid will continuously try to recover refrigerant. The symptoms of this condition can be identified as follows:

1. Failure of the unit to meet dehumidification expectations.
2. Discharge lines to both the reheat coil and the condenser coil remaining hot. In the reheat mode the discharge line to the condenser should be cool in stabilized reheat mode.
3. Small refrigerant recovery line between the bleed solenoids and the suction line remains hot. In the reheat mode this line should be cool.
4. Suction line at the compressor becomes hot due to continuous refrigerant recovery from the condenser coil.
5. On the 12.5 ton, solenoid #4 may open and close at a rapid rate.

As always, proper unit application, control and set-up are required for optimal unit performance.

Page three of this “Service Tips” letter explains the preferred field remediation to allow the unit to perform properly in the reheat mode. This method and instruction is the result of several weeks of rigorous lab review of units exhibiting this condition that were returned from the field specifically for Engineering evaluation and testing in a wide array of application conditions.

Parts needed:

Time delay relay, S1-ICM102

Double pole, double throw relay (DPDT), S1-02423972000

Additional wiring, 18 gauge 600V 105-C minimum.

This remediation is to be considered on a “Fix-On-Fail” basis only where the failure of the 3-way valve to fully actuate to the reheat mode is diagnosed. Validations of proper unit application, installation and set-up should be observed in conjunction with any conclusions regarding the 3-way valve performance before applying this modification.

If you have any questions on this feel free to call Factory Direct Northeast Technical Services at 1-855-251-8267 and speak with a technical support representative.

Regards,

Thomas Hoffmaster II

York Factory Direct Northeast

Area Service Manager

The following instructions are to provide direction to replace the current RHR (SPDT) with a (DPDT) relay with the addition of a Time Delay Relay. The purpose of this change is to provide a brief interruption of the compressor at the initiation of a call for dehumidification only and allow the Reheat Valve to fully shift to the reheat mode.

Disconnect power to the unit before proceeding with the installation and follow all safety practices!

Parts Required

Time Delay Relay: S1-ICM102

Double Pole Double Throw Relay (DPDT): S1-02423972000

Additional wiring & connectors: 18 gauge 600V 105-C minimum

1. Open the controls access door and locate the reheat relay, as shown in Figure 1
2. Disconnect all wires from the reheat relay and remove the (2) screws securing the reheat relay. Discard relay
3. Install the new reheat relay DPDT, secure using (2) screws removed from previous step
4. Install ICM102 time delay relay
5. Connect wiring as described in steps 6 thru 13, refer to Figure 2 below as needed
6. Connect wires 938/O and 952/O from UCB-AuxHGR and SOL2 to terminal 'A' on the new RHR relay
7. Connect 939/BR from TB2-2 to terminal 'B' on the new RHR relay
8. Connect 951/Y from SOL1 to terminal '7' on the new RHR relay
9. Connect 942/Y from TB2-3 to terminal '1' on the new RHR relay
10. Disconnect 212/Y for compressor contactor M1-A and re-connect to terminal '9' on the new RHR
11. Connect a new wire from compressor contactor M1-A to terminal '3' on the new RHR relay
12. Connect a new wire from terminal '1' on ICM102 to terminal '6' on the new RHR relay
13. Connect a new wire from terminal '3' on ICM102 to compressor contactor M1-A, since there may be only one terminal available on M1-A, a piggyback terminal may be required
14. The time delay relay ICM102 is adjustable up to 10 minutes. It is recommended to set the red dial to the 2-minute mark
15. After the time delay is set, close the controls access door, restore power to the unit and confirm unit operation



Time delay relay ICM102



Existing relay RHR, SPDT



New relay, DPDT

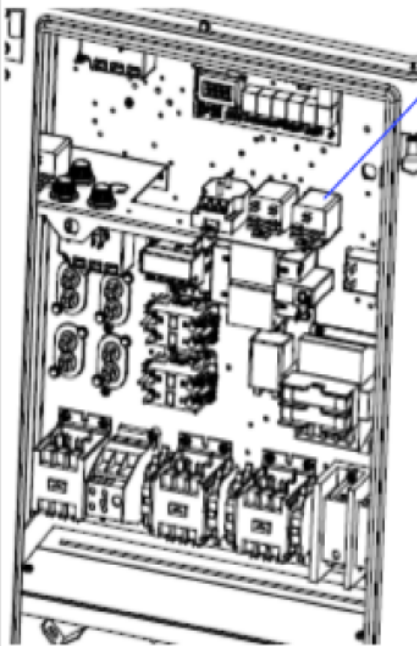

Figure 1.

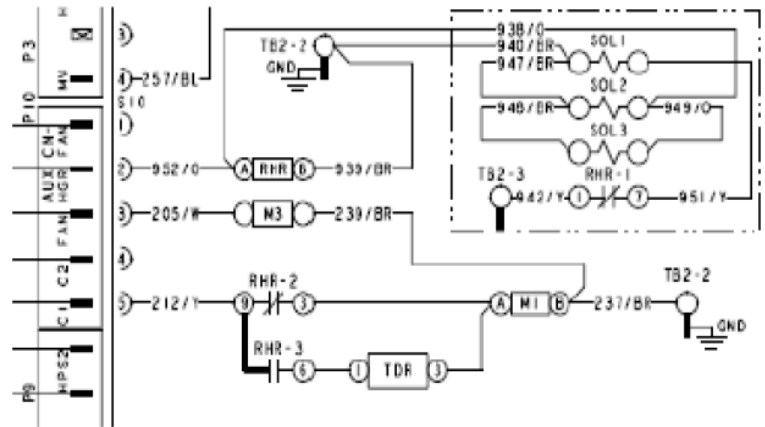

Figure 2.