

Smith Meter® microLoad.net™

Bulletin SS06045 Issue/Rev. 0.7 (7/17)

Electronic Preset Delivery System

The Smith Meter® microLoad.net® is a microprocessor based instrument with Ethernet capability. It is designed to monitor and control single product, straight loading. The unit can operate either as a stand-alone instrument or be part of system where it communicates with an automation or SCADA system.

FEATURES

- One arm, single product loading and unloading
- Standalone or remote controlled operation
- LACT control - BS&W monitoring, Sampler, Diverter
- Ethernet and serial communications
- Modbus and Smith communication protocols
- User authorization database and optional card reader
- Event, transaction and W&M audit logging
- User configurable load ticket and display
- Automatic volume correction of refined/crude liquids from LPG to asphalt based on temperature, pressure and density using API MPMS CH. 11.1-2004 Tables and all industry standard calculations
- TechnipFMC Promass Coriolis Meter communications for density and status
- Globally W&M and electrical safety approved
- Built-in web server for browser access
- Transaction log export to spreadsheet
- Programmable pulse output
- Fully programmable flow profile
- Optional display back-up per OIML
- Three levels of parameter access security
- Automated proving assistance
- Boolean/Algebraic custom logic expressions
- Additization of metered or unmetered products
- MicroMate configuration utility included
- Programmable language / messages
- Continuous monitoring of critical functions
- Pulse security level B



microLoad.net

Applications

The microLoad is ideal for any liquid transfer application requiring accurate weights and measures approved measurement and precise real-time control. Configurability has been built-in which allows every aspect of the operation to be tailored to fit a wide variety of situations.

Refined products – Batch loading/unloading of alcohol, gasoline, lube oils, fuel oils, solvents, fertilizers, LPGs, LNGs, and liquid chemicals into trucks, rail cars and barges. Ideal for bulk plants, shipping docks, processing installations, and tank farms where a single unblended product is transferred.

Crude Oil – The microLoad supports loading, unloading and LACT transfers of crude oil with built-in facilities to monitor and average BS&W, control a sampler with up to four sample cans, and full diverter valve control. Refer to publication AB06100 for additional information regarding upstream/crude oil applications.

Temperature Compensation

The temperature compensation feature provides the customer with the ability to compensate for variance in temperature from a reference temperature. This feature is used with an RTD input or a temperature transducer and, excluding the accuracy of the fluid temperature measurement, will exactly match the proper volume correction factor of ASTM-D-1250-04, and API MPMS CH 11.1 - 2004 tables as noted below, over the fluid temperature range of -58°F to 302°F (-50°C to 150°C).

The following API tables can be programmed in the microLoad.net: 5A, 5B, 5D, 6, 6A, 6B, 6C, 6D, 23, 23A, 23B, 23D, 23E, 24, 24A, 24B, 24D, 24E, 53, 53A, 53B, 53D, 53E, 54, 54A, 54B, 54C, 54D, 54E, 59A, 59B, 59D, 59E, 60A, 60B, 60D, 60E; also BR1A, BR1P, BR2P, and ETH/Gas (PTB), Aromat.

Pressure Compensation

Pressure compensation provides the customer with the ability to compensate the volume of product delivered at varying pressures per API Tables 11.2.1 and 11.2.2, using a 4-20 mA pressure transducer input. This feature also contains real-time control functions for maintaining system pressures at the meter to a minimally-acceptable, user-definable level (pressure transducer not included). Pressure compensation is particularly useful for light products, such as LPG, where the compressibility factor varies greatly with different pressures.

Density Correction

The density correction feature provides the customer with the ability to correct the volume of product delivered at varying densities (crude). The microLoad can read the line density as a 4-20 mA analog signal or through communications when using a Promass Coriolis meter.

Metered Injectors, Piston Injectors, and Smart Additives

The microLoad.net has been designed to provide maximum flexibility when it comes to additive control. The unit is capable of handling metered injectors, piston injectors and smart additives simultaneously.

The microLoad.net is capable of controlling four additive injector systems. (One metered injector and three piston or Smart or zero metered injectors and four piston or Smart.)

The microLoad.net controls the additive solenoids of metered injectors to precisely inject additive into the main product. It monitors the pulses of the additive meter and controls the amount of additive, based on the incoming pulses from the additive meter and main product meter.

Additive monitoring provides the capability for the microLoad.net to monitor feedback from the piston injectors of the additive products. The microLoad.net monitors the injector feedback switches for a change of state and counts the errors and alarms if no change is detected within the cycle or a period of time, depending on how the unit is programmed. The microLoad.net will totalize additive volume based on confirmation signals and a programmable volume per cycle. The totalized volume will print on the emulated load ticket printed on the printer output.

For Smart additives, the firmware has also been designed with a Master/Slave type of communications, with the microLoad.net being the master and the Additive Injector System being the slave. The microLoad.net constantly interrogates the Additive Injector System for a change in status. The microLoad.net can be operated with communications control over the Smart Additive Injector System or with communication/pulse control. When the microLoad.net has communication control over the Additive System, it will constantly monitor the Additive System for its status, poll the additive totals, and signal the system when to inject additive – all through the communications line.

The microLoad.net communications package has also been designed with a pass-through communications mode. In this mode of operation the supervisory computer can talk to the Additive Injector System through communication lines run to the microLoad.net and from the microLoad.net to the Additive Injector System(s).

Additization of Unmetered Products

The microLoad.net has a feature that allows it to additize products that do not have a meter providing pulses on the main product stream. This feature was added to provide a device to handle the injection of lubricity additive into low sulfur diesel where the diesel is not being metered. The microLoad.net has been designed to handle three separate scenarios for the application:

Scenario 1 – With meter on main product (standard method). microLoad.net receives pulses from product meter and paces additive accordingly.

Scenario 2 – Flow switch on main product line (no meter). No meter on the main product; the microLoad.net will simulate pulses. These pulses will be generated to match the selected high flow rate. Thus, the additive will be paced according to the predicted flow rate rather than the actual flow.

Scenario 3 – No flow switch or meter on main product. The microLoad.net will start simulating pulses when the START key is pressed; thus, an operator must be present. Similarly, the batch preset size must be accurate as the additization will be done over the entire preset amount.

Dual Pulse Security

This feature provides continuous monitoring and error indication alarm of pulse transmission for each preset position per API Petroleum Measurement Standard, Chapter 5.5, Level B, and Institute of Petroleum Standard, IP 252/76, Part XIII, Section 1, Level B.

Automated Proving Mode

The microLoad.net firmware provides an automated proving mode of operation. When the automated proving mode is activated, the microLoad.net will calculate the meter factor for a proving run based on information obtained during the prove. The operator can select the flow rate and meter factor being proved through the keypad of the microLoad.net. After the prove is complete, the operator enters the prover volume and prover temperature and the microLoad.net will calculate the new meter factor which the operator can download to the program or ignore. The microLoad.net also has the capability of providing an average meter factor over a maximum of ten batches. This feature allows the operator to prove the meter at up to four different flow rates without having to enter the program mode for each meter factor.

Boolean and Algebraic Processing

The microLoad.net provides the customer the flexibility to set-up inputs and outputs for tasks that are not standard in the unit. Through Boolean processing, relays can be turned on and off through equations and events set-up by the customer. For example, a relay is required to close at the first trip point of the load. This can be set-up using Boolean processing and does not require special software from the manufacturer.

Algebraic processing is also an area the customer can use to do simple mathematical calculations not in the unit. These calculations can then be used on the configurable reports or delivery display for the current transaction being run by the unit. The last 5 user boolean and the last 5 user float registers are also stored with the transaction.

Shared Printing

Shared printing allows multiple microLoads to generate reports on a single printer. A single microLoad.net can be configured to act as a "print server" (host) and all other microLoads to be "shared printers" (clients). Once the client microLoad.nets are configured as shared printers, they will have their communication, transmit, and receive lines tied together and connected to a single comm port on the print server. When a shared printer microLoad is done with a transaction and print is pressed on its keypad, the report is sent via communications to the host, where it will be printed.

Communications

The microLoad.net is equipped with three standard programmable communication ports that can be set up to be either EIA-232 or EIA-485 compatible communication ports, with baud rates up to 38,400 bps. In addition to these three communication ports an Ethernet port is available which supports FTP, HTTP, and Modbus/TCP protocols.

Hardware Options

OIML Display

The microLoad.net is designed to have two display options. The standard display option will operate until the power is lost and then will go blank. The OIML display option is the same display but when the power is lost, the display will maintain the data for reading by an operator for up to fifteen minutes.

Specifications

Accuracy

Calculated Accuracy: The gross at standard temperature to gross volume ratio, excluding the accuracy of fluid temperature measurement, will exactly match the proper volume correction factor or ASTM-D-1250-04 over fluid temperature range of -58°F to +302°F (-50°C to +150°C).

Temperature Measurement Accuracy: Fluid Temperature is measured to within +/- 0.72°F (+/-0.4°C) over the fluid temperature of -328°F to 572°F (-200°C to 300°C). Fluid temperature is measured to within +/-0.45°F (+/-0.25°C) over the fluid temperature range of 32°F to 572°F (0°C to 300°C)

Stability: 0.1°F (0.06°C)/year

Flow totalization within one pulse of input frequency

Electrical Inputs

AC Instrument Input Power

Dual Voltage input 115 or 230 VAC via Switch, 50/60 Hz

Power consumption: Approximately 9 watts.

Power Interruption Tolerance: Interruption of power greater than 0.05 seconds (typical) will cause an orderly shut-down of the microLoad.net and the control valve will be immediately signaled to close.

Digital (Meter Signal) Pulse Inputs

Type: Optically-isolated solid-state voltage sensors

Quantity: Two

Input Voltage Range: 5 to 28 VDC compatible

Pickup Voltage: 5 VDC minimum

Drop-Out Voltage: 1 VDC maximum

Current at Maximum Voltage: 20 mA maximum

Minimum Pulse Input Frequency: 3 Hz

Input Level Duration: 83 μ S minimum

Digital Control Inputs

Type: Optically-isolated solid-state voltage sensors

Quantity: Three

Input Voltage Range: 5 to 28 VDC compatible

Pickup Voltage: 5 VDC minimum

Drop-Out Voltage: 1 VDC maximum

Current at Maximum Voltage: 20 mA maximum

Input Level Duration: 120 mSec minimum

Analog Inputs

Type: 20-bit analog to digital converters

Function: One RTD, one 4-20 mA

Temperature (RTD – Resistance Temperature Device)

Type: Four-wire 100 Ω platinum resistance temperature detector (PRTD)

PRTD Temperature Coefficient @ 32°F to be: 0.00214 $\Omega/\Omega/^\circ\text{F}$ (0.00385 $\Omega/\Omega/^\circ\text{C}$)

Temperature Range: -148°F to +572°F

(-100°C to +300°C)

Temperature Measurement Accuracy: $\pm 0.72^\circ\text{F}$ ($\pm 0.4^\circ\text{C}$) over the specified range

Current (4-20 mA) Input

Type: Two-wire, 4-20 mA current loop receiver, programmable as to function.

Span Adjustment: Program adjustable

Input Burden: 50 Ω

Accuracy: $\pm 0.025\%$ of range

Resolution: One part in 1,048,576

Voltage Drop: Two volts maximum

Sampling Rate: One Sample/300 mSec minimum.

Electrical Outputs

DC Power

12 VDC $\pm 5\%$, 180 mA maximum, short circuited protected.

AC Digital Outputs

Type: Optically isolated solid-state output user-programmable as to function

Quantity: Four

Load Voltage Range: 90 – 280 VAC (rms) 48 – 63 Hz

Steady-State Load Current Range: 0.05A (rms) minimum to 0.50 amp (rms) maximum into an inductive load.

Leakage Current at Maximum Voltage Rating: 2.5 mA maximum at 240 VAC.

On-State Voltage Drop: 2.0 VAC at maximum load

DC Digital Outputs

Type: Optically-isolated solid-state output user-programmable as to function

Quantity: Two

Switch Blocking Voltage: 30 VDC maximum

Load Current: 150 mA maximum with 0.6 volt drop

Power down normally open

Pulse Output

Type: Optically-isolated solid state open-collector output.

Pulser output units are program selectable through the microLoad.net keypad or communications

Switch Blocking Voltage (Switch off): 30 VDC maximum

Load Current (Switch On): 10 mA with 0.6 volts drop

Frequency Range: 0 to 3000Hz

Duty Cycle: 50/50 (on/off)

Environmental

Ambient Operating Temperature

-13°F to 140°F (-25°C to +60°C)

Humidity

5 to 95% with condensation

Enclosure

Explosion-proof (NEMA7, Class I, Groups C and D) and watertight (NEMA4X), IP 65

Electrical Safety Approvals

North American: UL/CUL Listed 557N UL File E23545

Class I, Division 1, Groups C & D; Class II, Groups E, F & G

Class I, Zone1, AEx d ib IIB T6

UL Enclosure 4X, CSA Enclosure 4

Global

Ex d ib IIB T6 Gb ($U_m = 250\text{V}$) IP 65 Tamb = -25°C to 60°C

ATEX: DEMKO 04 ATEX 0403315X

IEC: IEC Ex UL 04.0007X

Weights & Measures Approvals

United States: NTEP CC 05-049

Canada: Measurement Canada NOA AV-2388 & AV-2387C

International: OIML R117-1 Test Report + WELMEC 7.2

European Union: MID Directive 2014/32/EU

For others, consult factory.

NMi Netherlands: Evaluation Certificate

Brazil: INMETRO/DIMEL No. 0143

Australia: Supplementary Certificate of Approval NMI S496

Electromagnetic Compatibility

European Union:

EMC Directive 2014/30/EU

EN 61326-1 Electrical equipment for measurement, control, and laboratory use.

COMMUNICATIONS

Serial:

Number of Ports: Three

Configuration: EIA-485 Four-wire or two wire Multi-drop network with optional termination resistor or EIA-232 Three-wire communications link

Data Rate: Programmable asynchronous data (Baud) rate from 2,400 to 38,400 bps

Data Format: Fixed at one start bit, one stop bit, eight data bits, and no parity

Line Protocol: Full duplex, no echo character

Data Structure: ASCII character oriented, modeled after ISO Standard 1155

Protocols: Smith Meter Terminal, Smith Meter mini computer, Modbus (PI-MBUS-300 Rev. D)

Ethernet:

Protocols: Smith/IP, Modbus TCP, http
10/100 Base TRJ-45

8 or 10 pin UTP (unshielded twisted pair) connector

microLoad.net – Modeling

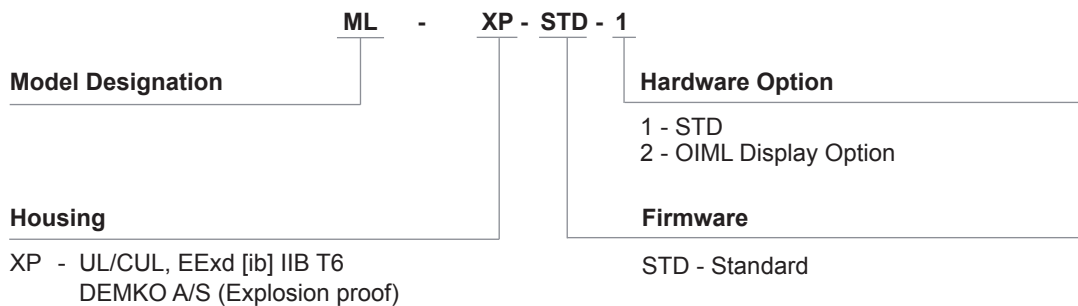

microLoad.net – dimensions

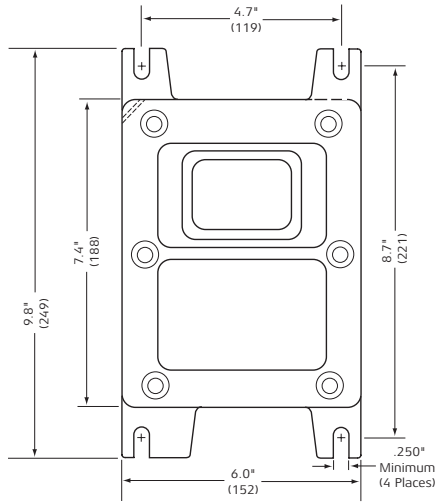

Conduit Entrances

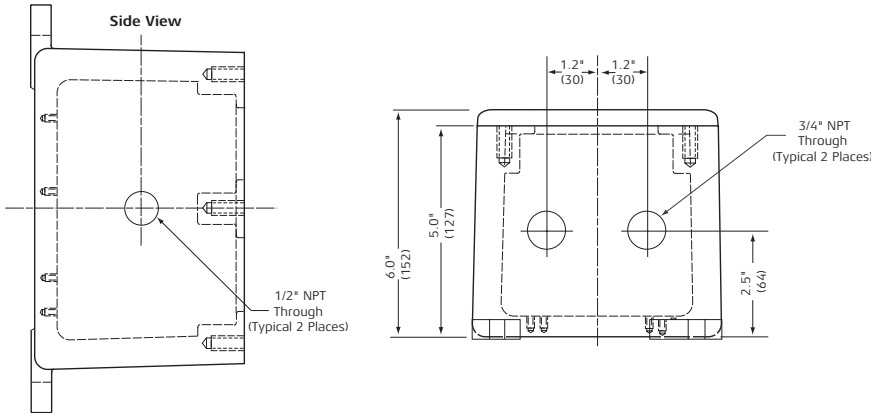

Explosion-Proof Housing

Note: Dimensions – Inches to the nearest tenth (millimetres to the nearest whole mm), each independently dimensioned from respective engineering drawings.

Revisions included in SS06045 Issue/Rev. 0.7 (7/17):

Updated Electrical Safety Approvals for North America and the Electromagnetic Compatibility directive for the European Union on page 5.

The specifications contained herein are subject to change without notice and any user of said specifications should verify from the manufacturer that the specifications are currently in effect. Otherwise, the manufacturer assumes no responsibility for the use of specifications which may have been changed and are no longer in effect.

Contact information is subject to change. For the most current contact information, visit our website at www.fmctechnologies.com/measurementsolutions and click on the "Contact Us" link in the left-hand column.

TechnipFMC.com

www.fmctechnologies.com/measurementsolutions

© TechnipFMC 2017 All rights reserved. SS06045 Issue/Rev. 0.7 (7/17)

TechnipFMC
FMC Technologies
Measurement Solutions, Inc.
500 North Sam Houston Parkway West,
Suite 100
Houston, Texas 77067 USA
P:+1 281.260.2190

USA Operation
1602 Wagner Avenue
Erie, Pennsylvania 16510 USA
P:+1 814.898.5000

Germany Operation
Smith Meter GmbH
Regentstrasse 1
25474 Ellerbek, Germany
P:+49 4101 304.0