

HydraLux

THE WORLD'S MOST ADVANCED POOL COVER



**TULLY
POOLS**

tullypools.com
404-307-6143



World Leaders in Automatic Pool Covers

A unique cover

HydraLux is the most advanced pool cover system designed and manufactured by **Aquamatic Cover Systems**. It is a European slat style that incorporates proven **Aquamatic** hydraulic technology.

The HydraLux is the only pool cover that provides automation without the use of tracks, ropes and leading edge bars found on traditional automatic cover systems. In addition, multiple covers can be deployed from a hidden recess in the pool floor to allow for complex pool shapes.

You are no longer limited in your pool design. Unique extruded rigid slats that can be cut to virtually any converging shape.

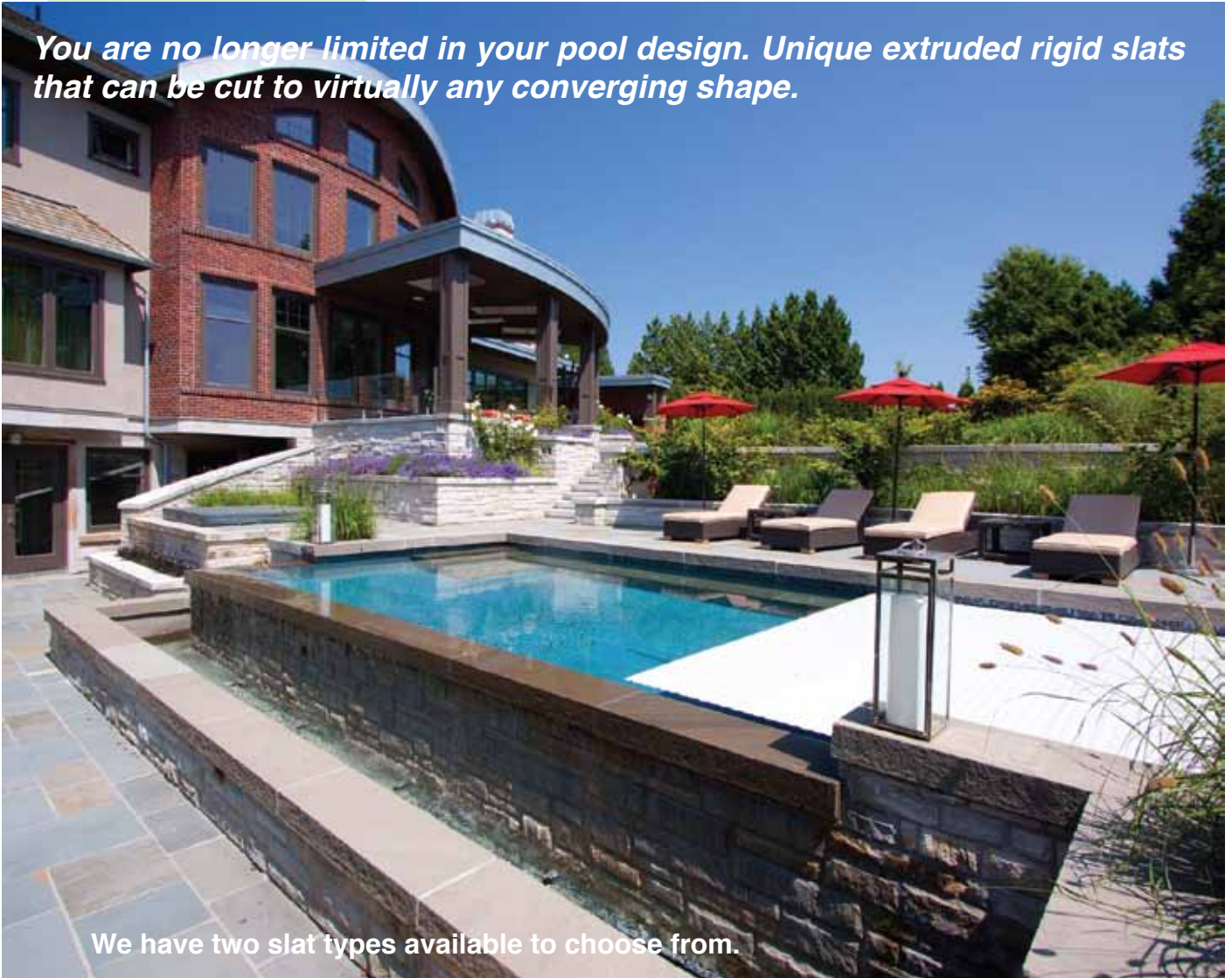

We have two slat types available to choose from.

Our standard slats are a hollow core with three air chambers, available in white, sand, light blue, and gray. We also have three optional slats with the hollow core, translucent, and two types of solar (translucent top/black bottom, and metallic top/black bottom). Additionally, Aquamatic has an exclusive solid core foam filled slat which is available in 4 colors. Blue Sky, Steel Gray, Silex Gray and Cream White. Either slat offers the highest aesthetic value and energy savings of any automatic swimming pool or spa cover available anywhere.

... for a unique pool

The HydraLux is designed as an automated energy savings device, and is **not to be considered a safety cover**. If the pool requires an ASTM F1346-91 safety cover, please consider our Hydramatic which exceeds this standard.

The HydraLux is a unique automatic pool cover that utilizes extruded rigid PVC slats. This slat design eliminates the rope track interface and can provide automation on pools that previously could not accept an automatic pool cover.

The design characteristic of the hollow slat uses three chambers, that when sealed provide a 1/2" airspace giving the cover an excellent insulating quality. We also have a solid foam core slat which offers an even greater insulating value. Ideal for commercial pools, or pools that are maintained in colder climates.



...limited only by
your imagination...

Water features, such as laminaires, spa overflows can run while the cover is closed.



This unique geometric pool design has a full perimeter “Lautner Edge” overflow which required the pool cover system to be installed in the floor of the pool. With precise construction techniques, advanced engineering and fabrication of the solid stainless steel, the In-floor lid system provided a virtually seamless finish for the exquisite glass tile finish of the pool.



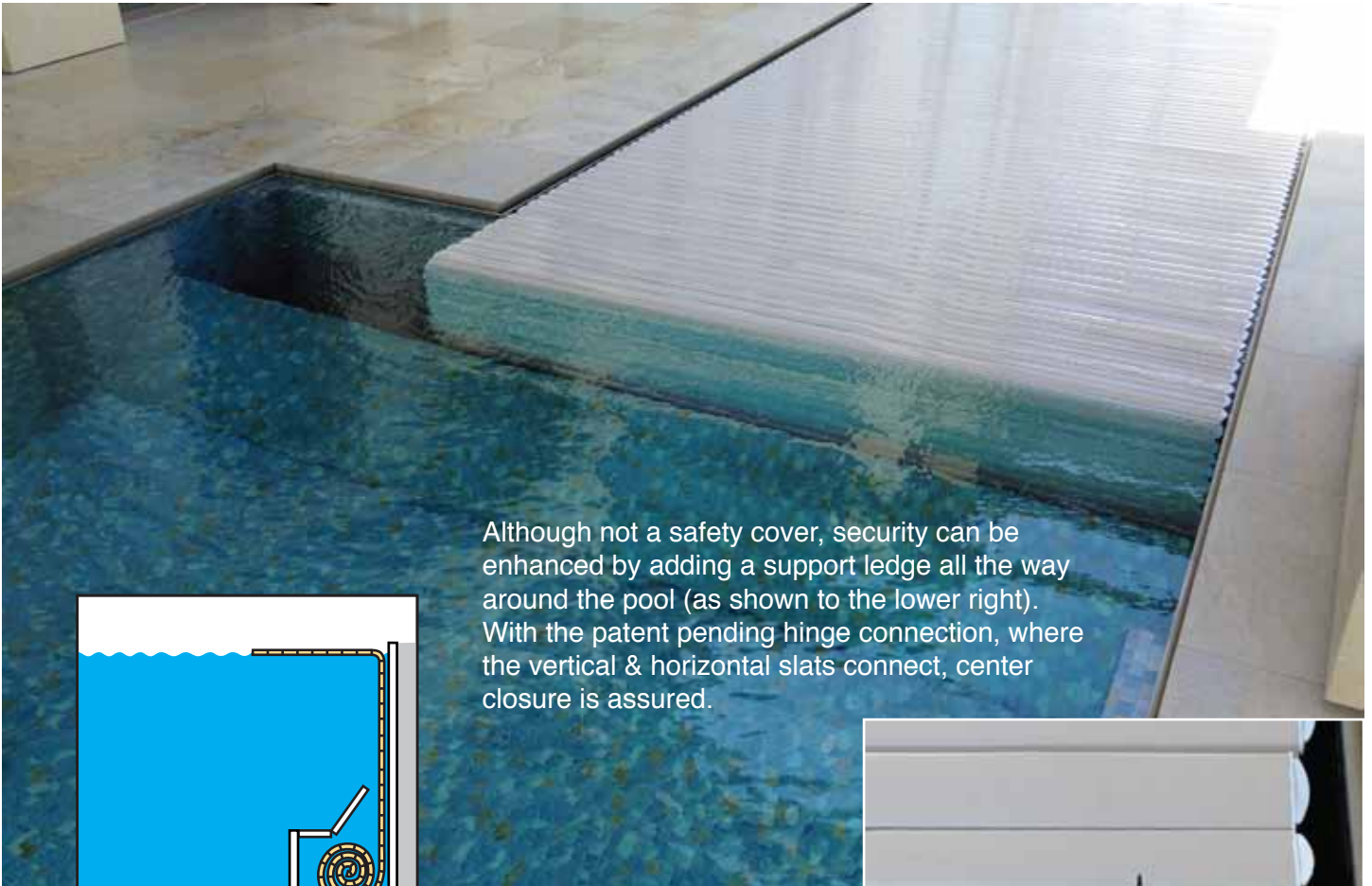

Although not a safety cover, security can be enhanced by adding a support ledge all the way around the pool (as shown to the lower right). With the patent pending hinge connection, where the vertical & horizontal slats connect, center closure is assured.

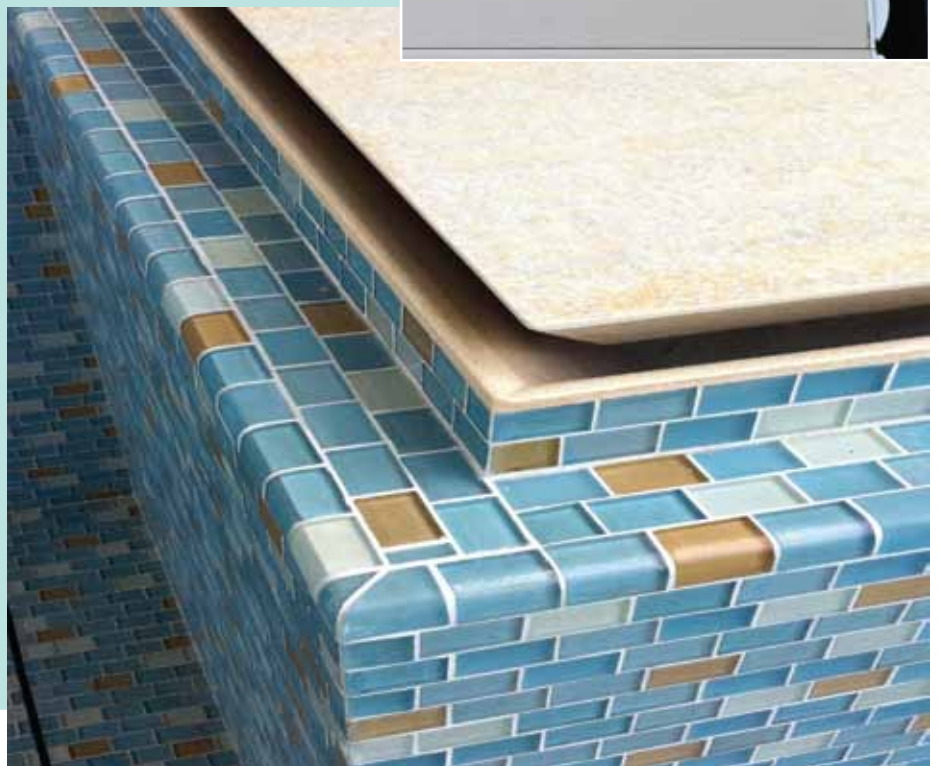
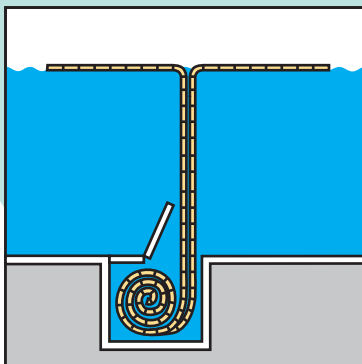
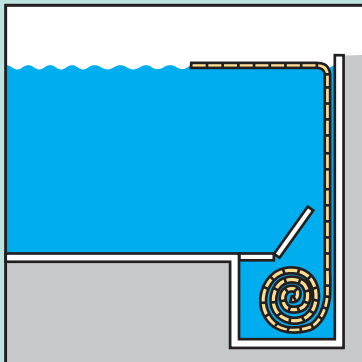
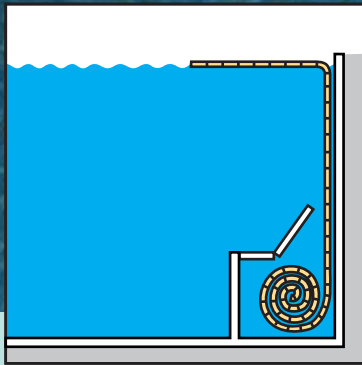

Our Product

The **HydraLux** is a unique trackless floating design which can cover any converging pool or spa shape. Fully automatic, this system is also ideal for any commercial application.

Operation

- Designed and developed by Aquamatic Cover Systems
- Proven automatic hydraulic drive technology.
- Key switch control standard or optional Touch pad.
- 20 year limited mechanism warranty.
- 5 year limited warranty on hollow core slat
- 6 year limited warranty on solid core slat

Installation

- Recessed, in-floor or deck mounted (see illustrations within this brochure).

Materials

- The pool cover consists of extruded rigid profiles floating on the water.
- PVC slats available in four standard colors, with three optional polycarbonate choices.
- Color matched end caps.

****NOTE: The HydraLux cover is NOT a safety cover.** It is solely designed as an energy saving device





Model # 1 in Gray

The HydraLux offers unmatched aesthetics. Along with its unique energy saving properties, the HydraLux will offer you an expedited return on investment while significantly reducing your pool operating costs, and enhancing your pool ownership experience.



Model # 1 in Light Blue



Model # 1 in Solar

Solid Core Slats

Another Aquamatic Exclusive



- Aquamatic has an exclusive solid core foam filled slat which offers the highest insulating value of any automatic swimming pool or spa cover.
- This option is available in 4 colors: Cream White, Silex Grey, Blue Sky and Steel Grey
- The solid core slat is supported by a 6 year limited warranty, the longest in the industry.





Model # 1 in Cream White



Model # 1 in Sky Blue



Model # 1 in Sand

Model #1 (Standard)



The recess can be covered with the same materials as the coping and/or deck surround. A stainless steel beam with perpendicular supports holds the custom stainless steel pans that can accommodate any masonry product. The beam and supports are keyed into the bond beam of the pool providing a secure fail-safe application.

In some cases, the stainless steel beam can be finished with the same materials as the pool finish as shown below right. Both the beam and pans are constructed of type 316 stainless steel. Special beam and pan details can be designed upon request.

The Standard HydraLux model installs in a flooded recess behind the pool. (See illustration to the right).

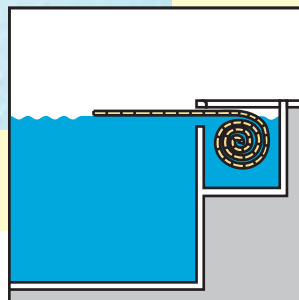

Model #2

This is our most adaptable HydraLux model. This in-floor application allows for any perimeter pool design, including zero edge, vanishing edge pools and pools of virtually any shape.

A type 316 solid stainless steel lid accepts all finishes and provides an almost seamless closure with superb aesthetics. The in-floor lid is hydraulically actuated and sequentially timed to work in unison with the hydraulic driven cover drum. A fail-safe limit switch stops the cover at the desired end of travel.



With oval and other non-rectangular pools or pools without a straight side/end, the cover can deploy from the center of the pool or other in-floor position.

All of the hydraulic components, including the lid ram, reducer, torque motor and limit switch are isolated in a dry external recess, adjacent to the pool wall.



Model #3, 4 & 5

Models 3 and 4 are similar in that they are installed under a cantilevered deck. In both of these applications the cover slats and drum assembly must be isolated from swimmers by a divider. This divider can be constructed in the same manner as model #2 in-floor lid and finished the same as the pool interior. The divider must be hinged and removable for cleaning and access to the pool cover recess.



Model 5 is limited to small pools or swim spas. A removable divider is also recommended for this type of installation.

On either of these limited applications, a custom roller assembly may be required to aid in deployment of the cover slats.



Protective dividers must be removable to allow servicing

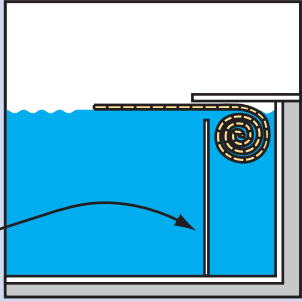

Model #3

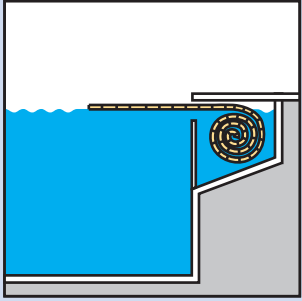

Model #4

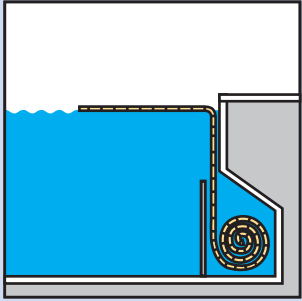

Model #5
(Limited to small pools or spas)



Model #6



This model's retrofit housing can automatically move over the pool water when deploying the cover to close and off the pool surface when opening the pool to swimmers. This application is optional, otherwise it can be mounted in a fixed application.

A composite polymer enclosure is available in six colors (white, tan, gray, charcoal gray, terra cotta and brown).

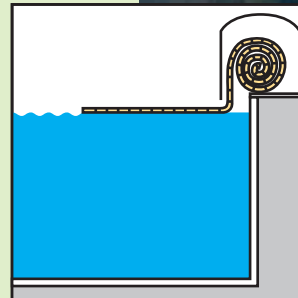

On outdoor pools the bench enclosure is mandatory if using the hollow core slat as the slats must be protected from sunlight when not in contact with the water surface.



HydraLux Gallery

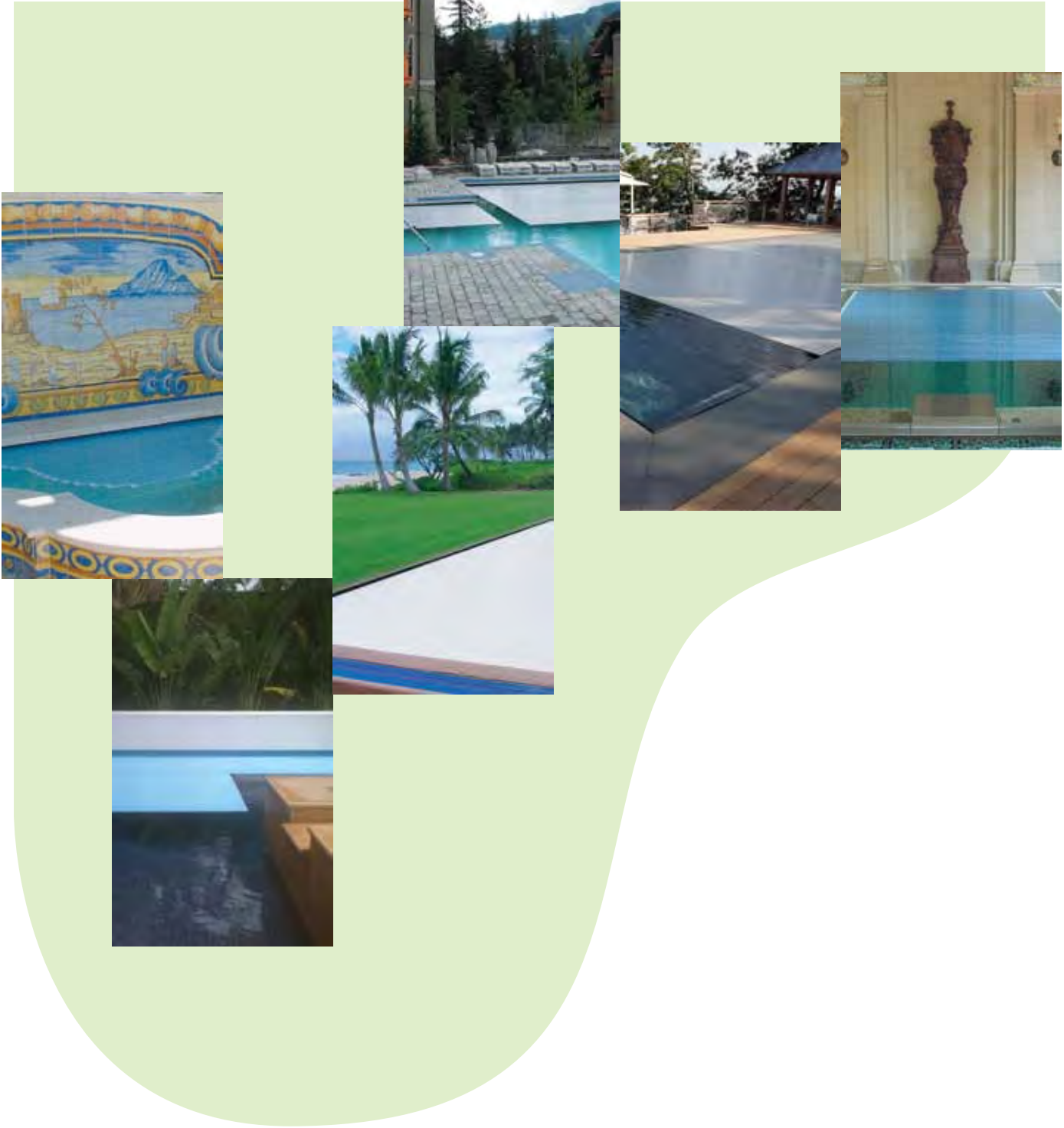

HydraLux Gallery



HydraLux Gallery



Double cover pool with a Model #2 solar slats.



Uniquely shaped Vanishing Edge pool with a Model #1 light blue slats.



HydraLux Gallery



HydraLux Gallery



HydraLux Gallery



Solid Foam Filled Core Color Gallery



Blue Sky



Silex Gray



Tan



Steel Gray



Cream White



Steel Gray

HydraLux Model #1 Standard Mount

A: CONTACT AQUAMATIC FOR COVER VAULT WIDTH
 B: CONTACT AQUAMATIC FOR COVER VAULT DEPTH
 C: 4" MINIMUM, REQUIRES 2" CLEAR BOTH ABOVE LOWERED BOND BEAM AND BELOW VAULT COVER LID SUPPORT COMPONENTS FOR HYDRALUX COVER CLEARANCE. REFER TO NOTE #1 AND VAULT SECTION DETAIL PAGE 2

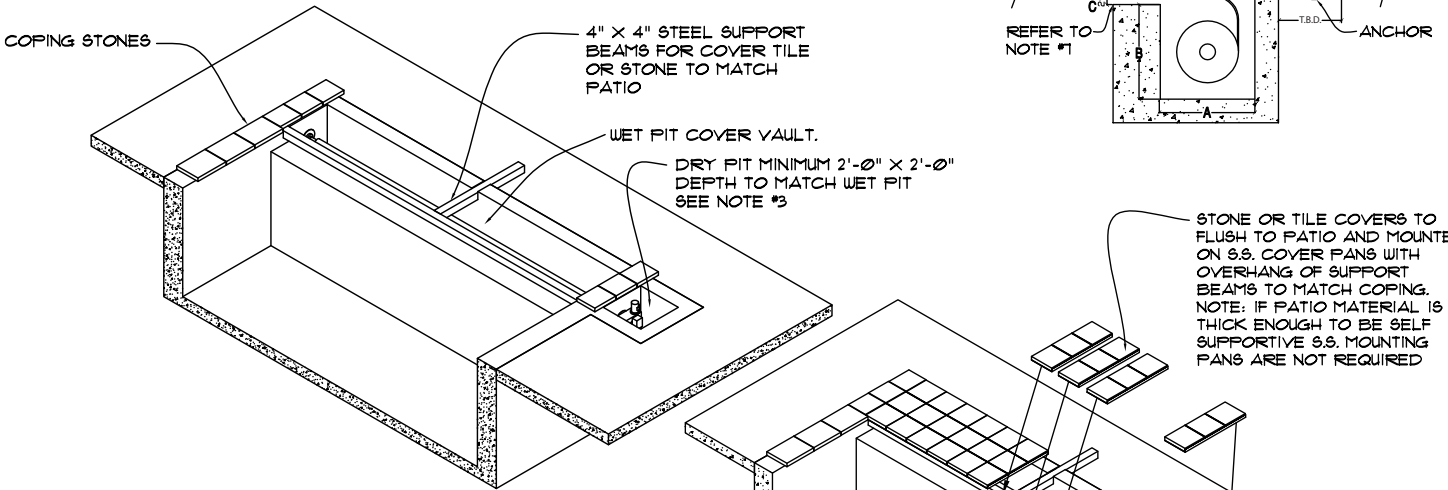
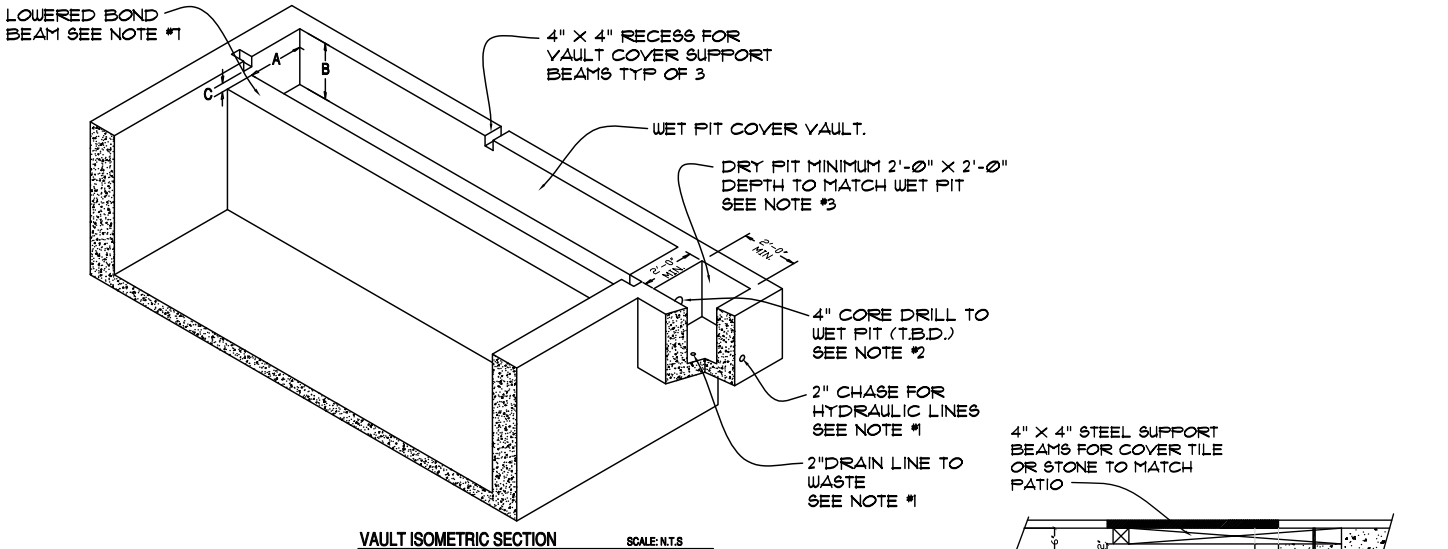

1. DRY PIT MUST BE EQUIPPED WITH DRAIN, AND ONE 2 CHASE FROM DRY PIT RETURNED TO THE EQUIPMENT PAD WITH SWEEP TURNS ONLY.
2. A 4" HOLE WILL BE CORED FROM THE WET PIT TO THE DRY PIT FOR WALL SHAFT PASSAGE ASSEMBLY, MAKE SURE THERE IS NO PIPING IN THE WALL BETWEEN THE WET AND DRY PITS. LOCATION TO BE DETERMINED AS PER AQUAMATIC.
3. DRY PIT MUST BE AT MINIMUM 24" X 24" WIDE (CENTERED) AND THE SAME DEPTH AS THE WET PIT . DRY PIT CAN BE LOCATED ON EITHER SIDE OF WET PIT. WET END WALL IS TO BE FLUSH TO POOL WALL.
4. IF USING A HOSE TYPE OF SWEEP, FLOATS MUST BE REMOVED TO KEEP HOSE BELOW WATERLINE, IN-FLOOR CLEANING SYSTEMS ARE PREFERRED.
5. FOR CIRCULATION AND WATER TREATMENT A DRAIN OR RETURNS MUST BE INSTALLED, CONSULT WITH THE POOL BUILDER FOR PLACEMENT AND REQUIREMENTS
6. ** CLEARANCES ARE CRITICAL, THEREFORE WATER LEVEL MUST BE MAINTAINED WITH AUTO-FILL AND OVERFLOWS **
7. FOR BOTH THE LOWERED BOND BEAM (END WALL), AND ANY LID COMPONENTS, (MEASURE FROM THE LOWEST POINT DOWN) THERE MUST BE A MINIMUM OF 2" CLEARANCE FROM BOTH (4" OVERALL) TO ALLOW THE COVER TO PASS WITHOUT OBSTRUCTION. IF THE COVER DOES NOT PASS FREELY, THE SLATS WILL GET BUNCHED UP INSIDE THE COVER HOUSING, WHICH CAN CAUSE SIGNIFICANT DAMAGE TO THE SLATS.

HydraLux Benefits

The HydraLux cover has the best insulating value compared to other traditional pool covers.

Saves Energy

The U.S. Department of Energy states that **75 % of heat loss is from evaporation**. Along with the evaporation, you will have water and chemical loss while incurring the cost of increased pump and filtration time of an uncovered pool. By utilizing an automatic pool cover you will eliminate your evaporative loss.



Saves Money



An automatic cover will reduce your pool operating costs by as much as 70 % through reduction of pool water, chemical and energy consumption. Additionally your other pool equipment will work less and last longer. You will also realize a full return on your cover investment in a relatively short time. * On indoor pools, the automatic pool cover will act as a vapor barrier, which allows you to reduce both the size and operating time of your dehumidification equipment saving you additional money. *

Saves Time

Spend less time skimming and more time swimming. A pool with a cover is always clean, warm and debris free. Which in turn, will allow you to have more time to enjoy your backyard oasis with your friends and family.



Saves Resources

If choosing the optional "Solar Slats" The HydraLux pool cover will act as a solar collector and will passively heat your pool through radiant transfer. Our customers have found on average their pool temperature has increased by as much as 10 to 15 degrees while also extending their swimming season.

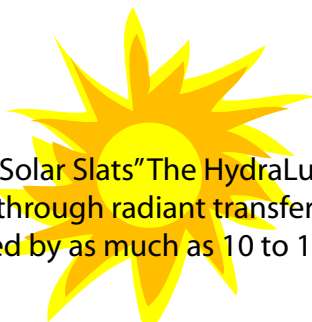

Photo credits: Alka Pools, Aloha Pools, Aquascape, Aquatic Consultants, Aquatic Technology, Bonavista Pools, Bay Area Pools, Canderle Pools, Creative Master Pools, Mission Pools, Nautilus Pools, North Coast Pool & Spa, Pacific Pools, Paradise Pools & Gardens, Soucy Aquatik