

LICENCE

for

Licensee:

Date:

To read the full licence agreement, simply click within the red box above and scroll through with your cursor

- Learn about LexConnect, All Jurisdictions, Standards referenced in Australian legislation
- Know when a Standard has changed
- Visit our store to find more Publications



Fire protection for mobile and transportable equipment



This Australian Standard® was prepared by Committee FP-022, Fire Protection of Mobile and Transportable Equipment. It was approved on behalf of the Council of Standards Australia on 20 June 2016.

This Standard was published on 11 July 2016.

The following are represented on Committee FP-022:

- Australasian Fire and Emergency Service Authorities Council
 - Construction and Mining Equipment Industry Group
 - Department of Trade and Investment, NSW
 - Fire Protection Association Australia
 - Mining Electrical and Mining Mechanical Engineering Society
-

This Standard was issued in draft form for comment as DR AS 5062:2015.

Standards Australia wishes to acknowledge the participation of the expert individuals that contributed to the development of this Standard through their representation on the Committee and through the public comment period.

Keeping Standards up-to-date

Australian Standards® are living documents that reflect progress in science, technology and systems. To maintain their currency, all Standards are periodically reviewed, and new editions are published. Between editions, amendments may be issued.

Standards may also be withdrawn. It is important that readers assure themselves they are using a current Standard, which should include any amendments that may have been published since the Standard was published.

Detailed information about Australian Standards, drafts, amendments and new projects can be found by visiting www.standards.org.au

Standards Australia welcomes suggestions for improvements, and encourages readers to notify us immediately of any apparent inaccuracies or ambiguities. Contact us via email at mail@standards.org.au, or write to Standards Australia, GPO Box 476, Sydney, NSW 2001.

Australian Standard[®]

Fire protection for mobile and transportable equipment

First published as AS 5062—2006.
Second edition 2016.
Reissued incorporating Amendment No. 1 (April 2017).

COPYRIGHT

© Standards Australia Limited

All rights are reserved. No part of this work may be reproduced or copied in any form or by any means, electronic or mechanical, including photocopying, without the written permission of the publisher, unless otherwise permitted under the Copyright Act 1968.

Published by SAI Global Limited under licence from Standards Australia Limited, GPO Box 476, Sydney, NSW 2001, Australia

ISBN 978 1 76035 528 9

PREFACE

This Australian Standard was prepared by Standards Australia Committee FP-022, Fire Protection of Mobile and Transportable Equipment, to supersede AS 5062—2006.

This Standard incorporates Amendment No. 1 (April 2017). The changes required by the Amendment are indicated in the text by a marginal bar and amendment number against the clause, note, table, figure or part thereof affected.

This Standard originated as Australian Coal Association Research Program, *Draft Code of Practice Fire Suppression Systems for Off-Road Mobile and Transportable Vehicles*. The scope has been expanded for applicability to vehicles and transportable equipment in other industry sectors.

The objective of the Standard is to formalize current good practice in reducing the incidence and severity of fires and to provide a consistent approach to fire risk reduction in order to safeguard life, property and the environment against fire associated with mobile and transportable equipment.

Providing protection against fire on mobile and transportable equipment poses unique and specific challenges, which general risk assessment methodologies do not necessarily address. This Standard is intended to assist in meeting those specific requirements.

This Standard references the requirements of the various fire protection systems Standards, with the exception of pre-engineered foam water spray systems. In the absence of an applicable Standard, the specific requirements for foam water spray systems are provided in this Standard.

Statements expressed in mandatory terms in notes to tables are deemed to be requirements of this Standard.

The terms ‘normative’ and ‘informative’ have been used in this Standard to define the application of the appendix to which they apply. A ‘normative’ appendix is an integral part of a Standard, whereas an ‘informative’ appendix is only for information and guidance.

This Standard incorporates a Commentary on some Clauses. The Commentary directly follows the relevant Clause, is designated by ‘C’ preceding the Clause number and is printed in italics in a panel. The Commentary is for information only and does not need to be followed for compliance with the Standard.

CONTENTS

	<i>Page</i>
SECTION 1 SCOPE AND GENERAL	
1.1 SCOPE.....	6
1.2 LIMITATIONS.....	7
1.3 REFERENCED DOCUMENTS.....	7
1.4 DEFINITIONS.....	7
1.5 INTERPRETATION OF SPECIFIED LIMITING VALUES.....	10
SECTION 2 FIRE RISK MANAGEMENT	
2.1 GENERAL.....	11
2.2 CONSULTATION.....	14
2.3 RECORDS.....	14
2.4 FIRE HAZARD IDENTIFICATION.....	14
2.5 FIRE RISK ANALYSIS.....	17
2.6 FIRE RISK EVALUATION.....	18
2.7 MONITORING AND REVIEW.....	19
SECTION 3 FIRE RISK REDUCTION	
3.1 GENERAL.....	20
3.2 DESIGN MEASURES AND SAFEGUARDS.....	22
3.3 ADMINISTRATIVE CONTROLS.....	24
3.4 DOCUMENTATION.....	25
3.5 FIRE PROTECTION SYSTEMS.....	25
SECTION 4 SAFETY REQUIREMENTS	
4.1 EMERGENCY PROCEDURES.....	27
4.2 EMERGENCY STOP DEVICE.....	27
4.3 SIGNS AND WARNING NOTICES.....	27
4.4 FIRE EXTINGUISHERS.....	30
SECTION 5 FIRE PROTECTION SYSTEMS	
5.1 GENERAL.....	31
5.2 FIRE PROTECTION SYSTEM FUNCTIONS.....	31
5.3 EXTINGUISHING AGENT.....	34
5.4 OPERATING CONDITIONS.....	34
5.5 FIRE SYSTEM SPECIFICATION.....	34
5.6 LISTING OF FIRE PROTECTION SYSTEMS.....	35
5.7 FIRE TESTING REQUIREMENTS FOR FOAM WATER SPRAY FIRE SUPPRESSION SYSTEMS.....	35
5.8 DESIGN AND INSTALLATION.....	36
5.9 EQUIPMENT MODIFICATIONS.....	36
5.10 DOCUMENTATION.....	36
5.11 FIRE PROTECTION SYSTEMS.....	37
5.12 SYSTEM SAFETY REQUIREMENTS.....	37

SECTION 6 FIRE PROTECTION SYSTEM DESIGN	
6.1	GENERAL..... 38
6.2	DESIGN DOCUMENTATION..... 38
6.3	SYSTEM DESIGN PROCEDURES 39
6.4	QUANTITY OF AGENT..... 41
6.5	EQUIPMENT SHUTDOWN 41
6.6	AIR HANDLING..... 42
6.7	DISCHARGE TIME 42
6.8	SYSTEM FLOW CALCULATIONS..... 42
6.9	CONTAINMENT OF EXTINGUISHING AGENT 42
6.10	IDENTIFICATION OF DISCHARGE NOZZLES 42
SECTION 7 SUPPLY	
7.1	STORAGE CONTAINERS 43
7.2	STORAGE CONTAINER ARRANGEMENT 43
7.3	IDENTIFICATION, MARKING AND LABELLING OF CONTAINERS..... 44
7.4	FIRE PROTECTION SYSTEM CONTROL VALVES 45
SECTION 8 DISTRIBUTION SYSTEM	
8.1	GENERAL..... 46
8.2	DISTRIBUTION SYSTEM SUPPORTS 46
8.3	COMPATIBILITY..... 46
8.4	INSTALLATION OF DISTRIBUTION SYSTEM 46
8.5	NOZZLES 46
SECTION 9 FIRE DETECTION, ACTUATION AND CONTROL SYSTEMS	
9.1	GENERAL..... 48
9.2	MANUAL ACTUATION 48
9.3	ELECTRICAL SYSTEMS..... 49
9.4	PNEUMATIC SYSTEMS..... 49
9.5	MECHANICAL SYSTEMS 49
9.6	CONTROL AND INDICATING EQUIPMENT 50
SECTION 10 COMMISSIONING AND ACCEPTANCE OF FIRE PROTECTION SYSTEM	
10.1	GENERAL..... 53
10.2	DISCHARGE TEST 53
10.3	SYSTEM FUNCTION AND OPERATION TEST 54
10.4	COMPLETION REPORT AND DOCUMENTATION..... 54
10.5	OPERATION AND MAINTENANCE MANUALS..... 55
10.6	TRAINING..... 55
SECTION 11 SERVICE OF FIRE PROTECTION SYSTEMS	
11.1	GENERAL..... 56
11.2	SERVICE PERSONNEL 56
11.3	RECORDS..... 56
11.4	PRECAUTIONS 58
11.5	RECHARGE OF EXTINGUISHING AGENT 58
11.6	SERVICE REQUIREMENTS..... 59
11.7	ROUTINE SERVICE SCHEDULES FOR PRE-ENGINEERED SYSTEMS 60

Page

APPENDICES

A	REFERENCED DOCUMENTS.....	65
B	TYPES OF RISK ANALYSIS.....	67
C	HOSE AND WIRING RETICULATION DIAGRAMS.....	69
D	ASSESSMENT OF COMPONENT COMPLIANCE FOR FIRE PROTECTION SYSTEMS	72
E	FIRE TEST METHOD FOR FOAM WATER SPRAY FIRE SUPPRESSION SYSTEMS.....	80
F	PRE-ENGINEERED FIRE PROTECTION SYSTEM SAMPLE COMMISSIONING REPORT	86
G	SAMPLE CERTIFICATE OF COMPLETION.....	89
H	FIRE PROTECTION SYSTEM—SAMPLE ANNUAL SYSTEM CONDITION REPORT	92

STANDARDS AUSTRALIA

Australian Standard

Fire protection for mobile and transportable equipment

SECTION 1 SCOPE AND GENERAL

1.1 SCOPE

This Standard specifies fire risk management procedures and the minimum requirements for fire protection system design, installation, commissioning, and maintenance for use on mobile and transportable equipment. The requirements for listing of fire protection systems and the testing requirements for pre-engineered foam-water spray systems are also specified.

NOTE: Mobile and transportable equipment is generally referred to in this Standard as 'equipment'.

This Standard may be applied to the following equipment and industries:

(a) Commercial and recreational vehicles, including the following:

- (i) Buses.
- (ii) Four-wheel drives.
- (iii) Road haulage.
- (iv) Motor homes.
- (v) Forklifts.
- (vi) Road registered plant.
- (vii) Pleasure craft.

NOTE: *National Standard for Commercial Vessels, Part C—Design and Construction, Section 4—Fire Safety* covers the requirements for commercial marine applications.

(b) Mobile and transportable equipment, including but not limited to the following industry sectors:

- (i) Mining and quarrying.
- (ii) Forestry.
- (iii) Waste management.
- (iv) Construction.
- (v) Railway.
- (vi) Agriculture.
- (vii) Defence.

This Standard is intended for new equipment however, it is recommended that the Standard be applied to existing equipment.

NOTE: For existing equipment, the fire risk assessment may identify the need for further risk reduction measures or modification of existing reduction measures (see Section 3).

1.2 LIMITATIONS

The requirements of this Standard do not override the requirements of regulatory authorities or the authority having jurisdiction.

The limitations of use for individual system agent standards shall apply in this Standard.

1.3 REFERENCED DOCUMENTS

The documents referred to in this Standard are listed in Appendix A.

1.4 DEFINITIONS

For the purpose of this Standard, the definitions below apply.

1.4.1 Approved and approval

Accepted by, or the acceptance of, the authority having jurisdiction.

1.4.2 Authority having jurisdiction

A minister of the Crown, a government department, or other public authority having power to issue regulations, orders or other instructions having the force of the law in respect of any subject covered by an Australian Standard or, in cases where none of these apply, the owner or the owner's agent.

1.4.3 Baseline data

As defined in AS 1851.

1.4.4 Competent person

A person who has acquired through training, qualifications or experience, or a combination of these, the knowledge and skills enabling that person to perform the task required.

1.4.5 Container

A cylinder or other vessel used to store the extinguishing agent.

1.4.6 Defects and non-conformance

1.4.6.1 Critical defect

A defect that renders a system inoperative.

NOTE: A critical defect is reasonably likely to have a significant adverse impact upon the safety of the operator and equipment.

1.4.6.2 Non-critical defect

A system impairment or faulty component not likely to critically affect the operation of the system.

1.4.6.3 Non-conformance

Missing or incorrect features that do not affect the system operation but are required to facilitate ongoing routine service.

NOTE: An example of non-conformance includes: use of non-approved parts to replace original components.

1.4.7 Directional valve

A device for controlling the passage of the extinguishing agent from a supply manifold to pre-selected area(s) of protection.

1.4.8 Distribution system

The pipework and fittings downstream of a container.

1.4.9 Effective discharge time

The period of time between the first appearance of extinguishing agent from the system discharge nozzles and the time at which the discharge changes from predominantly extinguishing agent to propellant. The end of the effective discharge is often accompanied by a characteristic change in the sound and appearance of the discharge.

1.4.10 Electrical clearance

The air distance between system equipment, including piping and nozzles, and unenclosed or non-insulated live electrical components.

1.4.11 Engineered system

A fire suppression system consisting of a supply of extinguishing agent connected to pipework where the quantity of agent and the size of each section of pipe and nozzle orifice has been calculated in accordance with the requirements of the system's design manual.

1.4.12 Extinguishing system unit

Identified components that are to be assembled into a system for the discharge of an extinguishing agent through fixed piping or hose, and nozzles for the purpose of extinguishing fires.

1.4.13 Fire suppression system

An engineered or pre-engineered system designed to suppress or extinguish a fire by either local application or total flood design methodology.

1.4.14 Foam water spray system

An automatic or manually actuated fixed distribution system connected to a foam-water supply and equipped with spray nozzles designed to provide a specific discharge pattern and distribution over the protected surfaces or area.

1.4.15 Hazard

A source of potential harm or a situation with a potential to cause loss.

1.4.16 Listed

Equipment, materials, or services included in a list published by an organization that is acceptable to the authority having jurisdiction and concerned with evaluation of products or services, and which maintains periodic inspection of production or listed equipment or materials or periodic evaluation of services and whose listing states that either the equipment, material, or service meets appropriate designated Standards or has been tested and found suitable for a specified purpose.

NOTES:

- 1 Examples of recognized testing and approval bodies are organizations accredited by JAS-ANZ, CSIRO Actifire, Factory Mutual (FM), Loss Prevention Certification Board (LPCB), SP Technical Research Institute of Sweden, Underwriters Laboratories (UL) and Verband der Schadenverhütung (VdS).
- 2 A manufacturer's statement of compliance does not by itself confirm that a system has been listed. The authority having jurisdiction should seek evidence of conformity to demonstrate that the system has been independently verified as being appropriate for the intended application.

1.4.17 Local application system

A fire suppression system arranged to discharge the extinguishing agent directly onto the burning material or identified fire hazard location, without the need for an enclosure to establish an effective concentration of extinguishing agent.

1.4.18 Lock-off device

A manual device installed in the discharge piping downstream of the agent containers, which, when closed, mechanically prevents agent reticulation into the protected area.

1.4.19 Manual

Requiring human intervention to accomplish a function.

1.4.20 Mobile equipment

Machine capable of being readily moved while in operation. It includes, but is not limited to, trucks, tractors, excavators, drills and the like.

1.4.21 Normally unoccupied space

An area not normally occupied, but which people may enter occasionally for brief periods.

1.4.22 Owner

The person or organization that has the legal rights to a particular piece of equipment.

Where the equipment is leased or financed such that the legal rights to the equipment are maintained by the finance company and the finance company has no interest in the operation of the equipment, then the owner is the person or organization that pays the finance company and/or has an option to purchase the equipment at the end of the lease or finance period.

1.4.23 Pre-engineered system

A fire protection system consisting of a supply of extinguishing agent of pre-determined quantity coupled to pipework with nozzle arrangement installed up to a maximum permitted design. No hydraulic calculations are required to size pipework or nozzles.

1.4.24 Risk

The chance of an occurrence of an event that will have an impact upon objectives.

1.4.25 Shall

Indicates a mandatory requirement.

1.4.26 Should

Indicates a recommendation or that which is advised but not mandatory.

1.4.27 Supervised

Continuous monitoring of the operational integrity or status of an electrical, mechanical, pneumatic or hydraulic feature of a system.

1.4.28 Survey

Visual inspection to identify if fire protection systems or equipment have been altered, damaged or compromised.

1.4.29 Total flooding system

A fire protection system arranged to discharge extinguishing agent into an enclosed space to achieve the appropriate design concentration.

1.4.30 Transportable equipment

Equipment that is designed to be periodically moved to a new position between periods of its operation. It includes, but is not limited to, pumps, generators, lighting towers, drills, high wall augers, mobile crushing plants and the like.

1.4.31 Visual warning device

A device that is illuminated or otherwise rendered visible at the appropriate time.

1.4.32 Warning notice

A permanently visible warning sign associated with the system.

1.5 INTERPRETATION OF SPECIFIED LIMITING VALUES

For the purpose of assessing compliance with this Standard, the specified limiting values are to be interpreted in accordance with the 'rounding method' described in AS 2706. That is, the observed or calculated value is to be rounded to the same number of figures as in the specified limiting value of 2.5, 2.50 and 2.500, the observed or calculated value would be rounded, respectively, to the nearest 0.1, 0.01 or 0.001.

SECTION 2 FIRE RISK MANAGEMENT

2.1 GENERAL

2.1.1 Fire risk management process

A fire risk management process is the systematic application of management policies, procedures and practices to identify, analyse, control, monitor and review fire risks at all phases of equipment life.

The fire risk management process shall be carried out in accordance with Figure 2.1 and AS/NZS ISO 31000, *Risk management—Principles and guidelines* or equivalent risk management Standard.

NOTE: SA/SNZ HB 436 provides guidance to AS/NZS ISO 31000.

The fire risk management process shall include the following stages:

- (a) Fire risk assessment—
 - (i) fire hazard identification;
 - (ii) fire risk analysis; and
 - (iii) fire risk evaluation.
- (b) Fire risk reduction (treat risks).
- (c) Fire risk monitoring and review.

NOTES:

- 1 The fire risk management process should be an integral part of the organization's occupational health and safety management system and should include a continuous improvement process (see AS/NZS 4801).
- 2 For further information see, NSW Department of Industry & Investment, Minerals Industry Safety and Health Risk Management Guidelines, Publication, MDG 1010, January 2011.

Consultation shall be carried out at each stage of the fire risk management process in accordance with Clause 2.2.

C2.1.1 *Phases of equipment life include the following:*

- (a) *Design.*
- (b) *Construction/acquisition.*
- (c) *Installation, assembly and commissioning.*
- (d) *Operation, including start-up and shutdown.*
- (e) *Maintenance, including breakdown, planned and preventive maintenance.*
- (f) *Modification.*
- (g) *Decommissioning and dismantling.*

2.1.2 Risk assessment

2.1.2.1 General

A risk assessment shall be carried out—

- (a) when equipment is designed;
- (b) prior to equipment being placed into service; and
- (c) when variations in design, use condition and environment could change the fire risk potential.

2.1.2.2 Process

The fire risk assessment shall be a structured process as follows:

- (a) Determine the possible fire scenarios:
 - (i) What can happen?
 - (ii) When and where can it happen?
 - (iii) Why and how can it happen?

NOTE: See Clause 2.4 for fire hazard identification.
- (b) Quantify the risk exposure by determining the likelihood and consequence of the fire scenarios:
 - (i) How likely is this to happen?
 - (ii) What are the consequences?

NOTE: See Clause 2.5 for fire risk analysis.
- (c) Prioritize fire risk—what risk needs to be addressed first?

NOTE: See Clause 2.6 for fire risk evaluation.

Figure 2.2 sets out the fire risk assessment process.

2.1.2.3 Methods

Appropriate risk assessment methods shall be used to analyse the fire risk.

Examples of methods that may be suitable are—

- (a) consequence analysis;
- (b) fault tree analysis (FTA);
- (c) event tree analysis (ETA);
- (d) failure modes effects analysis (FMEA);
- (e) human error analysis (HEA);
- (f) work place risk assessment control (WRAC);
- (g) hazard analysis (HAZAN); and
- (h) hazard and operability study (HAZOP).

More than one method may be required to identify all fire risks.

NOTES:

- 1 AS 4024.1201 and AS/NZS 40124.1302 provide guidance on methods that may be suitable.
- 2 Further information is available in, Joy, J. and Griffiths, D., *National Minerals Industry Safety and Health Risk Assessment Guideline*, Minerals Industry Safety and Health Centre, Version 6, June 2007.

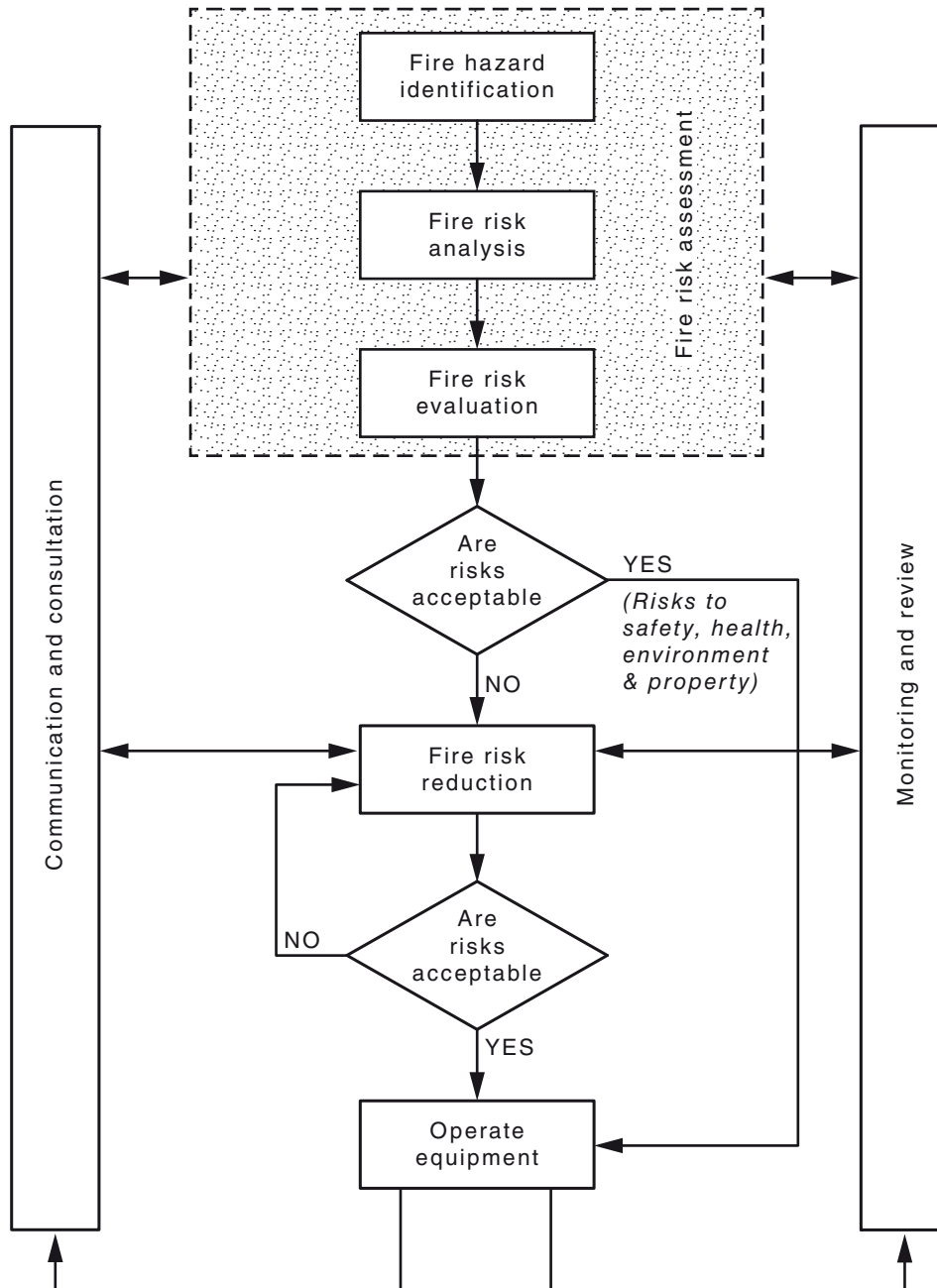

FIGURE 2.1 FIRE RISK MANAGEMENT PROCESS

2.1.3 Fire incidents

Previous fire experiences on similar equipment shall be considered at each stage of the fire risk management process.

NOTE: Manufacturers, owners and regulators should maintain a list of fire incidents.

C2.1.3 Past experience may indicate that special hazards exist, such as equipment that has an adverse fire history or component failure that increases fire potential.

2.2 CONSULTATION

The fire risk management process shall be carried out by personnel competent in risk-assessment and in consultation with the following person(s) where applicable:

- (a) Owner.
- (b) Operator.
- (c) Maintenance personnel.
- (d) Manufacturer's representative.
- (e) Supplier.
- (f) Hirer.
- (g) Insurer.
- (h) Specialist fire consultant.

NOTES:

- 1 Fire hazards and risks associated with mobile and transportable equipment are often too complex to be fully understood by one person.
- 2 Consultation regarding the fire hazards identified and risk reduction methods taken should be undertaken with at least three parties, including equipment operators and maintainers.

A risk assessment shall be completed and any recommended control measures shall be implemented. The organization, or a person appointed by the organization, that operates the equipment is responsible for ensuring that the fire risk assessment is completed and for the implementation of any recommended control measures. The residual risk should be acceptable to that organization.

2.3 RECORDS

The fire risk management process shall be fully documented for the life of the equipment. Records shall be maintained, including those associated with—

- (a) hazard identification, risk analysis and risk evaluation;
- (b) risk reduction methods;
- (c) consultation;
- (d) maintenance;
- (e) accidents, incidents and safety statistics; and
- (f) monitoring and review.

2.4 FIRE HAZARD IDENTIFICATION

2.4.1 General

A fire hazard exists where there is the potential for the interaction of fuel sources, oxygen and ignition sources. Fire hazards shall be identified in accordance with the process set out in Figure 2.2.

Consideration shall be given to whether the properties of materials can change over time or with use. Such changes may include the possibility of deterioration of the material, resulting in an increased fire risk.

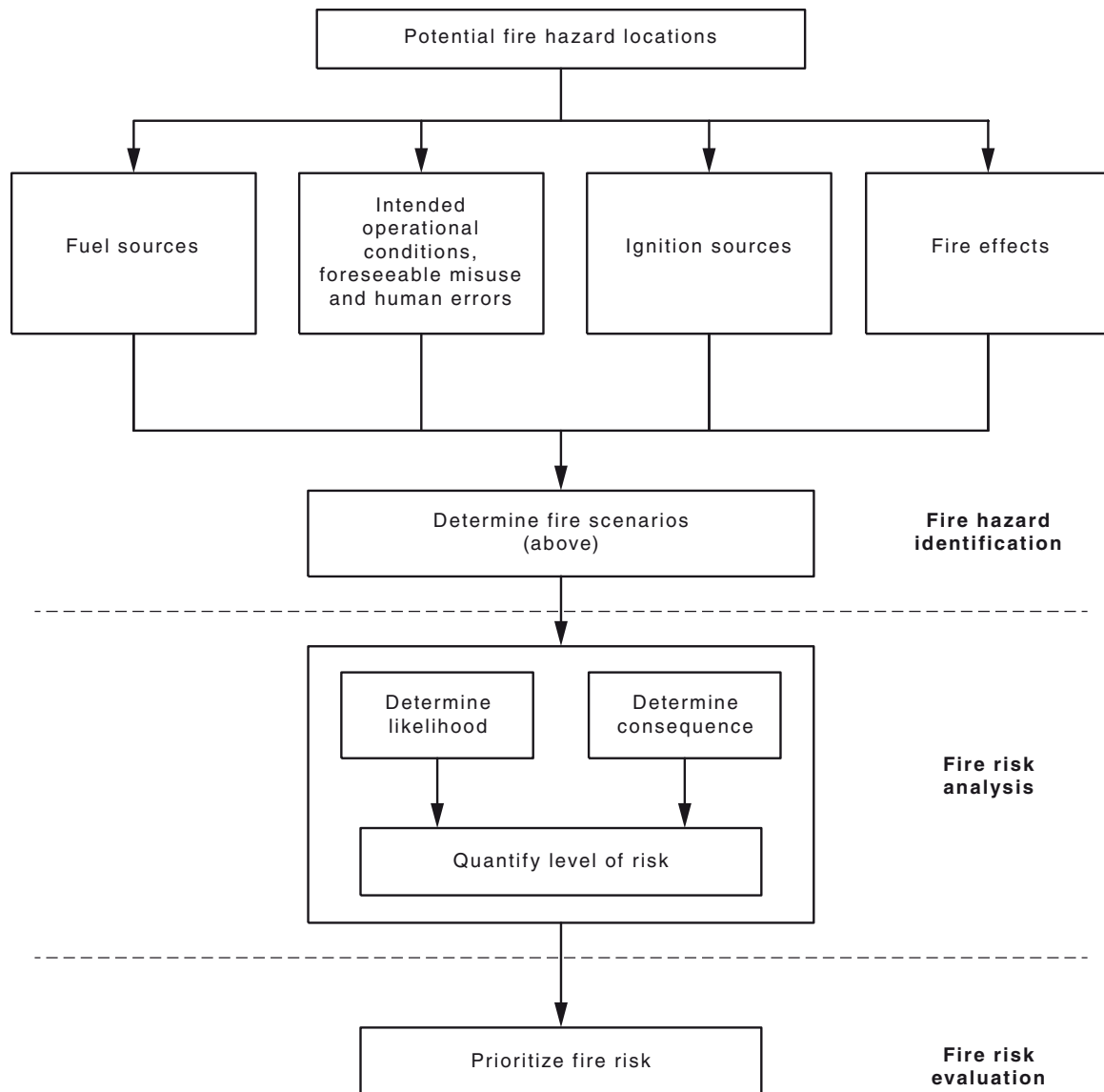

FIGURE 2.2 FIRE RISK ASSESSMENT

2.4.2 Fuels

2.4.2.1 General

When assessing the fire hazard location, all fuel sources shall be identified, including—

- primary fuel sources such as flammable liquids and lubricant;
- materials of construction of the equipment;
- the product being processed or transported; and
- the surrounding environment.

2.4.2.2 Types

Fuels to be identified may include, but not be limited, to those associated with the following classes of fire:

- Class A* Fires involving carbonaceous solids, which normally burn under the formation of glow, e.g. wood, textiles, rags, paper, rubber, electrical insulation or conduit, coal or flammable dust, construction materials, upholstery, hoses, tyres, seats, combustible debris and many plastics.

- (b) *Class B* Fires involving flammable and combustible liquids, e.g. diesel, petrol, hydraulic fluid, grease, lacquer, resin, tar, ether, alcohol, oils and some coolant combinations.
- (c) *Class C* Fires involving combustible gases, e.g. LP Gas, methane, propane and hydrogen.
- (d) *Class D* Fires involving certain combustible metals, e.g. magnesium, aluminium, lithium, sodium, potassium and their alloys.
- (e) *Class E* Fires involving electrically energized equipment, e.g. fuels of any other class.

2.4.2.3 *Properties*

The properties of the fuels shall be considered, including the following:

- (a) Ignitability.
- (b) Flammability.
- (c) Combustibility.
- (d) Quantity and continuity of supply.
- (e) Toxicity and combustion products.
- (f) Environmental impact of fire effluents.

NOTE: Where the fire properties of materials cannot be found in technical literature or the fuel's materials safety data sheet, appropriate testing of the materials or components may need to be carried out.

2.4.3 **Oxidizers**

When assessing the fire hazard, the existence and quantity of fire supporting substances and the probability of their occurrence shall be determined.

C2.4.3 The most common oxidizer is air but there are other oxidizers that support combustion, e.g. ammonium nitrate.

2.4.4 **Ignition sources**

When assessing the fire hazard, all ignition sources shall be identified, including but not limited to the following:

- (a) *Heat energy*—for example, high temperatures and hot surfaces are usually found in the vicinity of internal combustion engines, exhaust systems, pumps, turbochargers, batteries, wiring, switches, electric motors, generators, heat exchangers, bearings and brakes.
- (b) *Electrical energy*—for example, switch gear, motors, retarders, transformers, batteries, lights, cables, short circuit and electric arc, earth or conductor fault, discharge of static electricity, loose contact and induction heating.
- (c) *Mechanical energy*—for example, welding and cutting, friction, overheating, impact, grinding.
- (d) *Chemical reaction*—for example, self-heating, self-ignition and runaway exothermic reaction.

2.4.5 **Potential fire hazard locations**

Particular fire hazard locations associated with equipment shall be identified, including, but not limited to, the following:

- (a) Turbo chargers.

- (b) Fuel systems, including piping, hoses, pumps valving and injectors in close proximity to ignition sources.
- (c) Cooling system, including hydraulics, engine and transmission.
- (d) Exhaust systems.
- (e) Hydraulics systems, including piping, hoses, pump and valving.
- (f) Lubrication systems, including engine and transmission systems and grease systems.
- (g) Braking systems, including retarders, park brakes and service brakes.
- (h) Electrical systems, including alternators, generators, batteries, wiring and switch gear.
- (i) Locations where combustible materials can accumulate, e.g. bellyplates, engine valleys and wheel arches.
- (j) Tyres.
- (k) Tyre filling compounds.
- (l) Conveyor belts.

NOTES:

- 1 Potential fire hazard locations may be remote from the fuel or ignition source, for example, a liquid can spray or drip onto a hot surface remote from the leak point.
- 2 An electrical short conductor may transfer heat to another area of the equipment.
- 3 Fires involving tyres represent a significant safety hazard due to the potential for explosive deflation.

2.4.6 Operating environments

When assessing the fire hazard, the operating environment of the equipment shall be considered.

Particular fire hazard operating environments associated with the equipment include situations where the equipment fire will impact on the environment (e.g. forests/bushfires), or the environment will impact on the equipment. Fire hazards associated with the operating environment include the likelihood of combustible dust (e.g. coal), combustible gases, timber, confined spaces, oil spills, fuel and waste dumps/depos, tyre storage areas, and temperature.

2.5 FIRE RISK ANALYSIS

2.5.1 General

The fire risk on equipment shall be determined by analysis in accordance with Figure 2.2.

NOTES:

- 1 Semi-quantitative or quantitative risk analysis should be used in preference to qualitative risk analysis. Semi-quantitative or quantitative analysis methods allow risk to be equally ranked and prioritized.
- 2 Additional information on risk analysis is given in Appendix B.

2.5.2 Fire risk determination

2.5.2.1 General

The fire risk analysis shall determine the risks for the following, where applicable:

- (a) Health and safety of the operator and passengers.
- (b) Health and safety of people in the vicinity.
- (c) Property loss.

- (d) Production loss.
- (e) Environmental damage.

2.5.2.2 Fire effects

The effects of fire shall be considered in the risk analysis, including—

- (a) fire propagation;
- (b) thermal radiation;
- (c) products of combustion (e.g. smoke, toxic gases);
- (d) escaping materials into the surrounding area (e.g. pine forests); and
- (e) fire effluent.

2.5.3 Operational conditions

The potential for operational conditions to increase the fire risk shall be considered, including, but not limited to, the following:

- (a) Poor maintenance practices, e.g. rags left in engine compartment, removal of oils and greases, re-routing of hoses and modifications, housekeeping, use of incorrect materials, cleaning, changes of wiring and circuitry.
- (b) Operating environment, e.g. unshot ground, road conditions, road gradients, equipment speeds, gases and build-up of combustible materials.
- (c) Time of day.
- (d) Operator use/misuse, e.g. park brake being left on, brakes dragging and emergency brakes being used as service brakes.
- (e) Wear and tear of components.
- (f) Life cycle of components, e.g. hoses deteriorating, hoses and electrical cables rubbing and electrical conduit deteriorating.
- (g) Equipment interaction, e.g. refuelling and collisions.
- (h) Inexperienced operator(s).
- (i) Operator human error.

2.5.4 Existing risk controls

The fire risk analysis shall include analysis of existing controls, including but not limited to the following:

- (a) Paths of normal and emergency egress for operations personnel.
- (b) Means of fire detection (e.g. visual).
- (c) Availability of portable extinguishers.
- (d) Availability of fire-fighting personnel, external support and time to respond.
- (e) Procedures and training of operator(s).

2.6 FIRE RISK EVALUATION

The fire risk evaluation process shall compare fire risks against acceptance criteria and shall set priorities for further actions and fire risk reduction (treatment).

If the results of the risk evaluation indicate an unacceptable level of risk exists, then fire risk reduction measures shall be undertaken in accordance with Section 3.

2.7 MONITORING AND REVIEW

The fire risk management process shall be a continuous improvement process. It shall be monitored and reviewed—

- (a) periodically at intervals not exceeding five years;
- (b) whenever changes are made to the equipment that could affect the fire risk;
- (c) whenever variations in use, condition or environment could change the fire risk potential;
- (d) when there is a change of owner; and
- (e) after fire accidents or incidents occur.

SECTION 3 FIRE RISK REDUCTION

3.1 GENERAL

3.1.1 Risk reduction hierarchy

Risk reduction shall be primarily achieved by design/engineering measures that eliminate or minimize the fire hazards.

A risk elimination/reduction hierarchy shall be followed until the risk is reduced to an acceptable level.

NOTE: The preferred hierarchy for risk reduction measures is set out in Figure 3.1. It shows the order of reduction measures preferred to least desirable.

The residual risk after the use of controls, safeguards or fire protection measures shall be documented.

Risk reduction measures shall be considered at each level of the hierarchy in accordance with Figure 3.2.

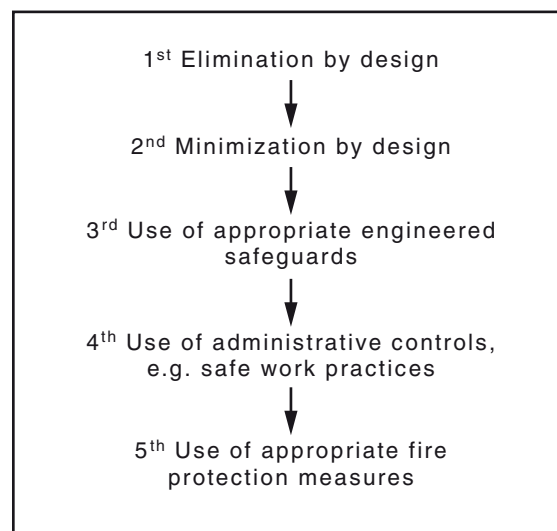

FIGURE 3.1 HIERARCHY OF FIRE RISK REDUCTION

3.1.2 Introduction of further risk

Proposed fire reduction measures shall not introduce other unacceptable risks. Other unacceptable risks include, but are not limited to—

- (a) obstruction of access and egress;
- (b) obstruction of vision;
- (c) changes to equipment systems;
- (d) obstruction of controls; and
- (e) adverse effects of extinguishing agent e.g. the use of electrically conductive fire extinguishing agents on energized electrical equipment.

HIERARCHY OF REDUCTION MEASURES

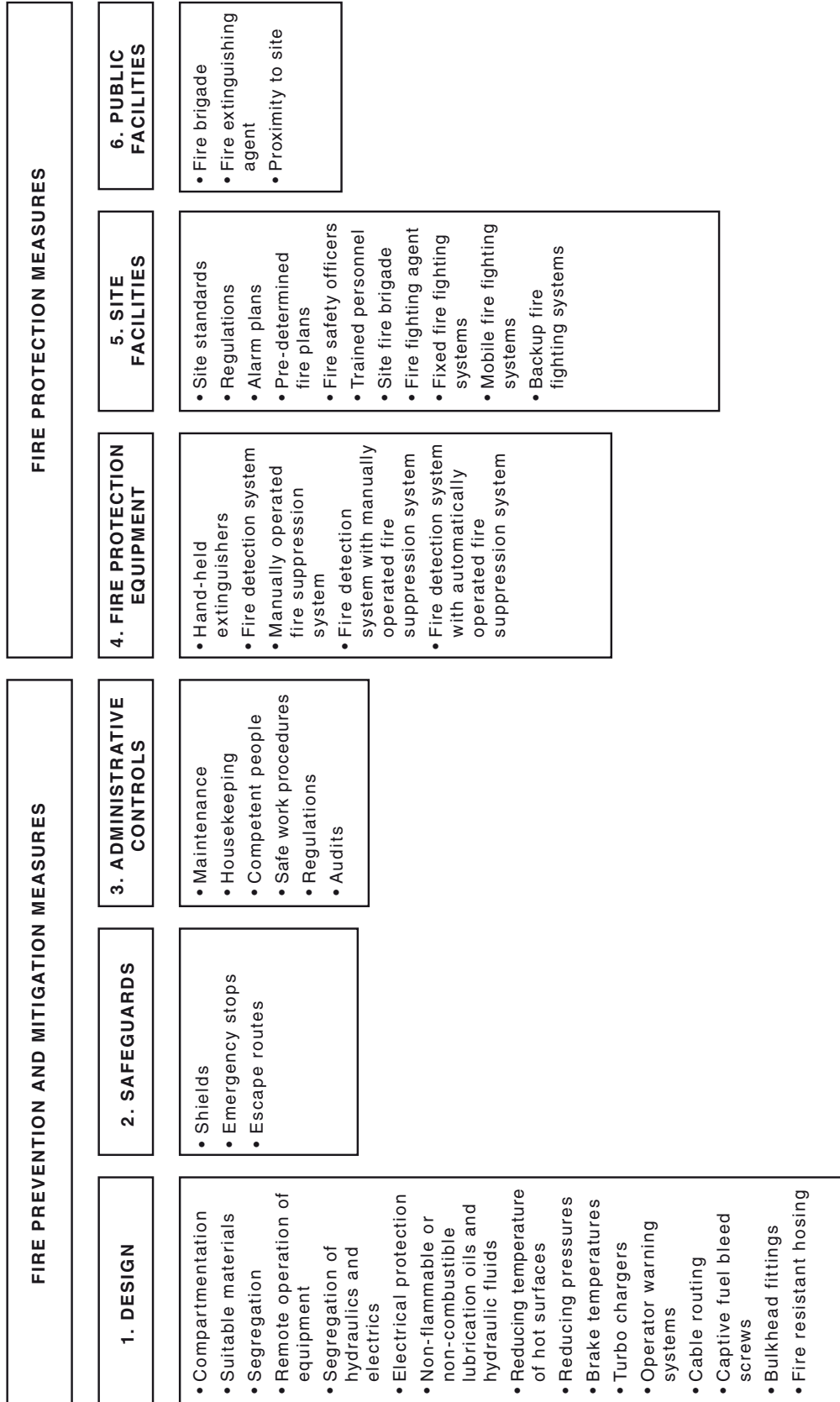

FIGURE 3.2 FIRE RISK REDUCTION MEASURES

3.2 DESIGN MEASURES AND SAFEGUARDS

3.2.1 General

The intended use for the mobile and transportable equipment under which the equipment is to be operated shall be documented, e.g. operating temperatures, hazardous environments and industry sector.

NOTE: Any modifications made to the original design should be carried out in consultation with the manufacturer.

3.2.2 Fuel sources

Design for fire risk reduction shall include consideration of fuel sources. Design measures to be considered for fuel sources shall include, but not be limited to, the following:

- (a) Use of materials of construction (or operation of the equipment) that are non-combustible, non-flammable or have reduced combustibility or flammability.
- (b) Use of hoses and pipes that are correctly rated for their application.
- (c) Use of hoses and fittings that comply with AS 3791.
- (d) Use of fire-resistant hose to suit its location.

NOTE: Standards for fire resistance of hose include testing to AS 1180.10B or ISO 8030 with an average glowing not exceeding 30 s, or Type 1 or Type 3 hose as detailed in ISO 6801.

- (e) Routing of hoses away from hot surfaces.
- (f) Use of adequate clamping of hoses and pipes with consideration given to vibration during operation and susceptibility to damage during maintenance.
- (g) Use of metal pipes or metal-braided hose for pressurized fuel lines.
- (h) Use of shields where hydraulic hoses may be damaged by impact, e.g. in wheel arch areas and under the body.
- (i) Routing of pipes and hoses in a manner that will provide mechanical protection against wear and damage.
- (j) Emergency manual shutdowns for immediate shutdown of fuels.

3.2.3 Ignition sources

Design for fire risk reduction shall include consideration of ignition sources. Design measures that shall be considered include, but are not limited to, the following:

- (a) Minimization of hot surfaces.
- (b) Use of correctly rated interlocks to prevent misuse of components that have a high risk of generating a fire, e.g. park brake interlock to propulsion or retardation.
- (c) Use of protection devices for electrical circuits, e.g. circuit breakers, fuses, current limiting devices.
- (d) Use of correctly rated electrical circuits.
- (e) Use of extra-low voltage wiring that complies with AS 4242, where applicable.
- (f) Protection of electrical cables and components against mechanical damage.
- (g) Design of electrical connections such that they cannot loosen or overheat under normal conditions of service.
- (h) Covering and securing of batteries to prevent short-circuiting.
- (i) Adequate ventilation of battery enclosures.

- (j) Wiring—
 - (i) using suitable mechanical protection, e.g. guards and sheathing;
 - (ii) to be enclosed, e.g. conduits and glands to prevent ingress of fuel sources and contaminants;
 - (iii) using bulkhead fittings where electrical conduits penetrate enclosures or partitions;
 - (iv) arranged so as to facilitate regular visual inspections; and
 - (v) arranged to prevent contact with any hot surfaces.

3.2.4 Overheating

Design for fire risk reduction shall include consideration of overheating, including, but not limited to, the following measures:

- (a) Reducing the possibility of overheating under normal operating conditions of—
 - (i) the equipment; and
 - (ii) the materials processed by the equipment, e.g. gases, liquids, solids, dusts or vapours.
- (b) Use of monitoring and control systems where overheating may occur. Examples where monitoring control systems may be required include—
 - (i) brake drag;

NOTE: Numerous fires have occurred due to equipment being driven with the brakes applied.
 - (ii) engine;
 - (iii) hydraulic systems; and
 - (iv) retard systems.
- (c) Use of tyres with appropriate tonnes kilometres per hour (TKPH) ratings for the intended duty.
- (d) Design of oil-immersed braking systems to prevent the temperature of the oil reaching its flashpoint when operated in accordance with the manufacturer's operating parameters.

NOTE: The oil used in braking systems should be as specified by the equipment manufacturer or manufacturer-approved equivalent.
- (e) Use of fire-resistance fluids as cooling mediums.

3.2.5 Segregation

Segregation of fuel and ignition sources shall be considered as a design measure for fire risk reduction, including, but not limited to, the following:

- (a) Separating electrical cabling from hydraulic and fuel hoses.
- (b) Routing of hydraulic and fuel hoses away from high-risk ignition sources such as the turbocharger and exhaust pipework.
- (c) Routing of services including hydraulic lines, oil lines and electric power cables outside the engine compartment.
- (d) Use of shields to protect ruptured services from spraying onto potential ignition sources, e.g. hydraulically driven fans to prevent oil coming into contact with ignition sources.
- (e) Use of guards and shields to segregate fuel and ignition sources.

- (f) Use of firewalls to separate fuel and ignition sources (e.g. engine and hydraulic compartment).

NOTES:

- 1 Firewalls should be designed not to interfere with compartment ventilation.
- 2 See Appendix C for examples of unacceptable and good wiring arrangements.

3.2.6 Accumulation of combustible or flammable materials

Areas where fuel can accumulate shall be reduced.

3.2.7 Reduction of fire effects

Possible fire effects, including flames, heat and smoke shall be reduced. Consideration shall be given to the following methods of reducing fire effects:

- (a) The use of covers, shields or guards constructed from fire resistant material if the failure of the shields or guards is likely to place an operator at risk when a fire occurs.
- (b) The use of effective shielding of the operator from the engine compartment and other fire-hazard locations.

3.2.8 Miscellaneous

Consideration shall be given to—

- (a) reduction of fatigue-related fractures through improved bracketing methods and cable and hose routes; and
- (b) the potential for physical damage to services during maintenance work.

3.3 ADMINISTRATIVE CONTROLS

3.3.1 Maintenance and housekeeping

3.3.1.1 Maintenance

Maintenance works shall be carried out in accordance with the equipment manufacturer's recommendations.

3.3.1.2 Hot work

Hot work shall be carried out in accordance with AS 1674.1 and AS 1674.2. The level of risk shall be assessed and appropriate fire protection measures shall be in place prior to commencement of hot work.

3.3.1.3 Combustible materials

Combustible materials such as rubbish, oily rags, coal, timber, lubricants and leaks shall not be permitted to accumulate to create a fire hazard.

3.3.1.4 Inspection and cleaning

Regular inspection and cleaning shall be conducted to reduce the potential for fire risk.

The equipment shall be inspected for—

- (a) accumulation of materials;
- (b) rags left behind;
- (c) clamps not being tightened;
- (d) missing clamps;
- (e) incomplete maintenance that may have created additional fire risk; and
- (f) damage or deterioration of hoses or mechanical components.

3.3.1.5 Replacement parts

Replacement parts shall be at least equal in performance to the original parts. Examples include hoses, bearings, fittings and electrical equipment.

3.3.2 Training

All personnel shall receive training covering the following topics and specific to the environments in which the equipment is to be operated:

- (a) Fire hazards associated with the equipment.
- (b) Design measures and controls to reduce the fire risk.
- (c) Fire protection systems on the equipment, if fitted.
- (d) The use of fire extinguishers.
- (e) Actions in the event of a fire.
- (f) Reporting of faults and defects.

3.4 DOCUMENTATION

Documentation shall be provided to enable the owner to maintain the equipment, including fire prevention measures, in a correctly operating and safe condition.

Documentation on fire prevention measures and protection equipment shall include information on—

- (a) commissioning;
- (b) operation;
- (c) maintenance;
- (d) warnings of any residual fire risks; and
- (e) definitions and descriptions of interfaces between the fire system and the equipment, e.g. engine shutdown.

3.5 FIRE PROTECTION SYSTEMS

3.5.1 General

A fire protection system shall be provided when the fire risk cannot be reduced to the desired level by design measures and administrative controls (see Clauses 3.2 and 3.3).

The appropriate type of fire protection system shall be selected in accordance with Figure 3.3 and Clauses 3.5.2, 3.5.3 and 3.5.4 and designed in accordance with Section 6.

3.5.2 Automatically operated fire suppression system

An automatically operated fire suppression system shall be installed unless there are valid reasons why the automatic fire suppression system cannot be used. Valid reasons may include—

- (a) increased risk to health and safety of people as a result of operating the automatic system; or
- (b) where risk is reduced to an acceptable level by a manually operated fire suppression system or a fire detection and alarm system alone (see Clauses 3.5.3 and 3.5.4).

3.5.3 Manually operated fire suppression system

A manually operated fire suppression system shall incorporate a fire detection and alarm system unless the configuration of the equipment permits the operator to readily identify a fire.

3.5.4 Fire detection and alarm system

A fire detection and alarm system alone shall only be used where a response to the alarm will enable the operator to evacuate and manual intervention reduces risk to an acceptable level.

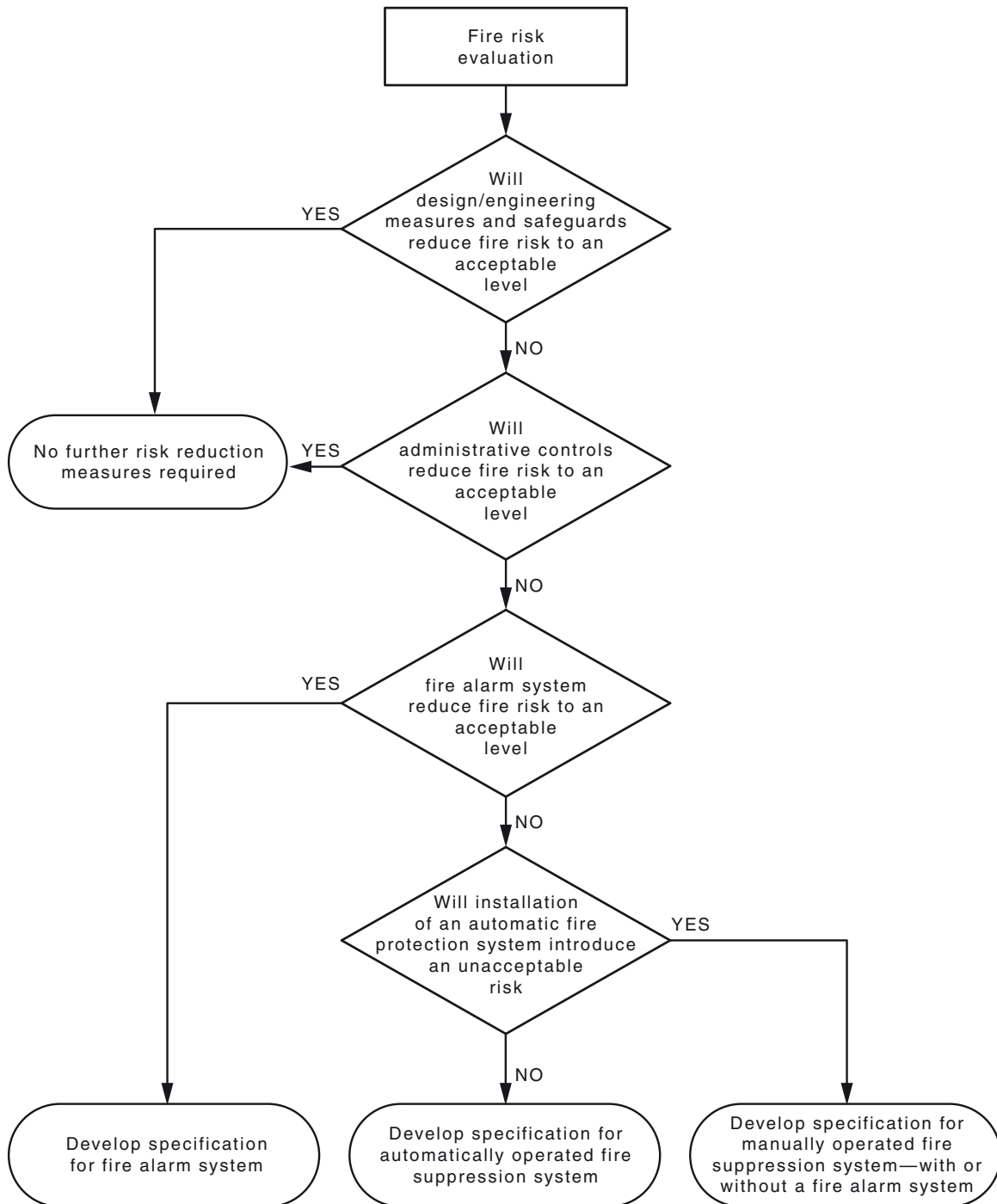

FIGURE 3.3 SELECTION OF FIRE SUPPRESSION SYSTEMS

SECTION 4 SAFETY REQUIREMENTS

4.1 EMERGENCY PROCEDURES

Procedures shall be in place to manage the safety of personnel in the event of fire. Personnel shall be trained in the procedures.

4.2 EMERGENCY STOP DEVICE

Emergency stops, where fitted, shall be installed in accordance with AS 4024, AS 1604 or ISO 13850.

4.3 SIGNS AND WARNING NOTICES

4.3.1 General

All safety signs and warning notices shall be designed and installed in accordance with AS 1318 and AS 1319. They shall be—

- (a) of durable, corrosion-resistant construction;
- (b) permanently attached; and
- (c) positioned so they are clearly visible.

NOTE: Signs and notices text may be replaced or accompanied with pictograms where appropriate. Refer to ISO 6405-1 and ISO 6405-2 for examples of pictograms.

4.3.2 Action in the event of fire

A vehicle fitted with a fire suppression system shall have a safety sign displayed within the operating cabin. Safety signs shall state the required action in the event of a fire, and be in white lettering on a red background.

NOTE: Figure 4.1 provides an example of typical instructions stating required action.

***C4.3.2** Many operators forget to shut down equipment when abandoning plant with the result that damage to equipment and danger to other persons can be aggravated. A number of operators have been placed at a higher risk of injury because the equipment was not shut down and a fire was still being fed by the fuel source while they evacuated.*

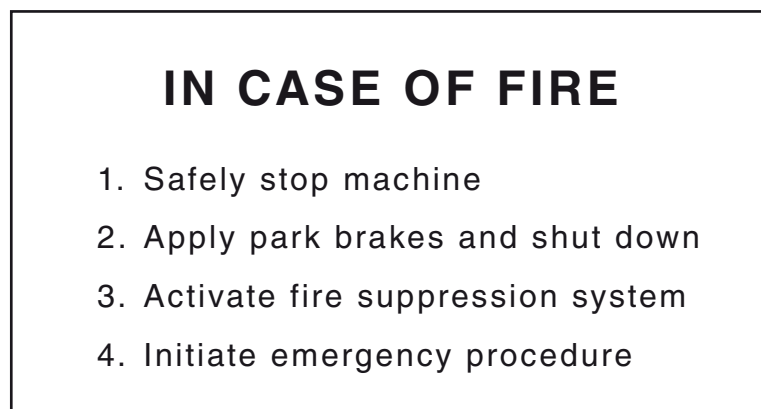

FIGURE 4.1 TYPICAL INFORMATION STATING REQUIRED OPERATOR ACTION

4.3.3 Fire protection system warning notices

Equipment fitted with a fire protection system shall be fitted with a warning notice advising that a fire protection system is fitted and there is potential for the equipment to automatically shut down.

NOTE: Figure 4.2 provides an example of a typical warning notice.

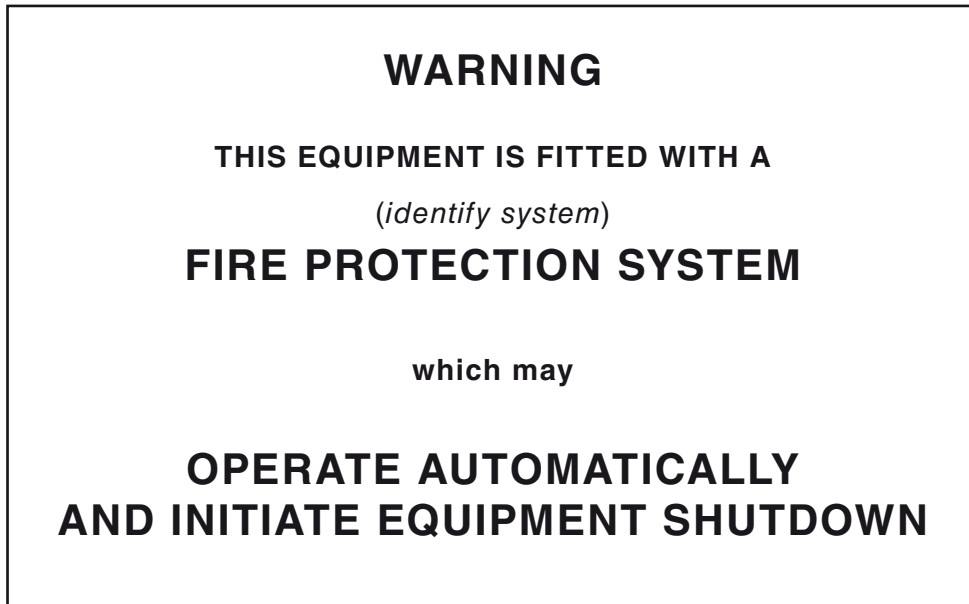

FIGURE 4.2 TYPICAL FIRE SYSTEM WARNING NOTICE

Where the fire protection system includes time delays, such as a shutdown delay, shutdown delay extension or discharge delay, the details of the delay periods shall also be specified on a warning notice fitted in the operator’s station.

NOTE: Figure 4.3 provides an example of a time delay warning notice.

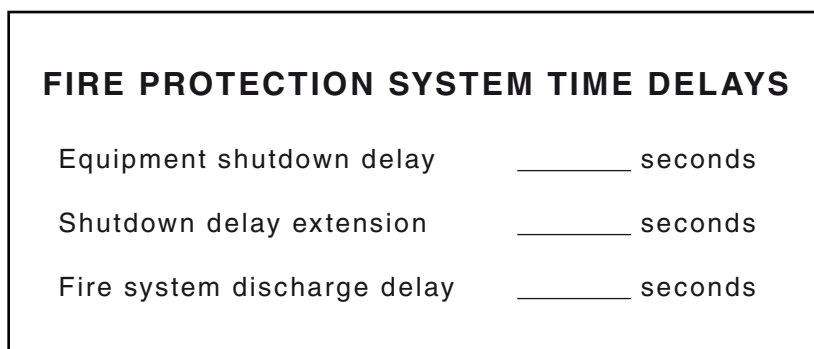

FIGURE 4.3 TYPICAL FIRE SYSTEM TIME DELAYS NOTICE

Where the discharge of a suppression system fitted in an occupiable space may have an adverse effect on the habitable conditions within that space, suitable warnings notices shall be provided at the entry points to the space.

NOTES:

- 1 Figure 4.4 provides an example of a typical isolation warning notice.
- 2 These hazards may include reduced visibility and toxic effects, both during and after the discharge period.



FIGURE 4.4 TYPICAL FIRE SYSTEM ISOLATION WARNING NOTICE

Warning notices for suppression systems shall comply with the requirements of the appropriate extinguishing agent, or suppression system design Standard as detailed in Clauses 6.3.2 and 6.3.3.

Warning notices shall be in black lettering on a yellow background.

4.3.4 Manual actuation instruction notice

Manual actuation instruction notices shall be provided at each manual actuation point.

Manual actuation instruction notices shall be in white lettering on a red background.

NOTES:

- 1 Requirements for manual actuation points are set out in Clause 9.2.
- 2 Figure 4.5 provides an example of a typical manual actuation instruction notice.
- 3 Use of pictograms may be acceptable for manual actuation instruction notices.

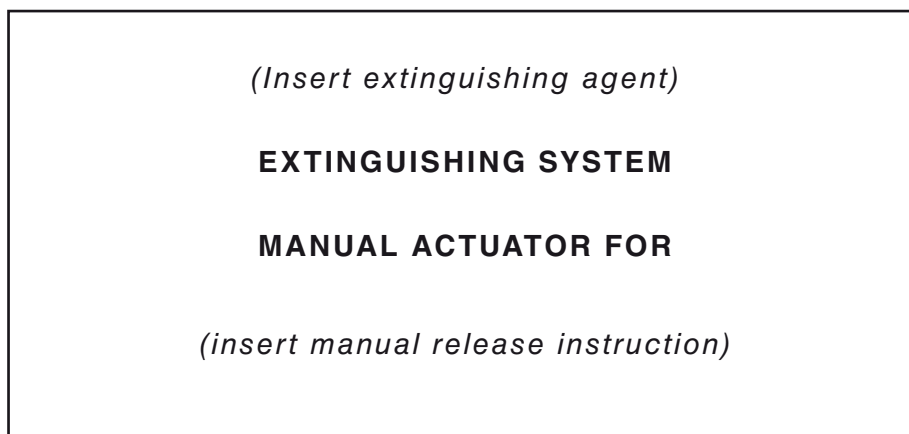

FIGURE 4.5 TYPICAL INSTRUCTION NOTICE TO BE DISPLAYED AT THE MANUAL ACTUATOR

4.4 FIRE EXTINGUISHERS

4.4.1 General

The installation of automatic or manual fire suppression systems shall not eliminate the need for portable fire extinguishers.

Fire extinguishers shall be selected, installed and maintained as required by this Clause, and AS 2444, but in no case shall be less than that required by the regulatory authority having jurisdiction.

The provision of an extinguisher shall be considered for equipment not controlled by an operator.

4.4.2 Selection

The fire risk assessment shall be used to determine the—

- (a) size;
- (b) number;
- (c) placement;
- (d) rating; and
- (e) nominal capacity, of extinguishers required.

4.4.3 Operator training

The operator shall be appropriately trained in the use of the fire extinguisher(s). Appropriate training in extinguisher use shall take into account, the—

- (a) type of equipment;
- (b) area of operation;
- (c) type of extinguisher; and
- (d) type of any fire protection system fitted.

C4.4.3 Extinguishers are most effective where used by trained operators. However, considering the size and configuration of equipment, fires can be difficult, impossible or dangerous to fight with a hand-held extinguisher. The key to operator protection is early detection of fires to provide warning to the operator, fuel shut off to minimize fuel for the fire, and fire suppression during its early stages.

If a fire protection system is not fitted, trained persons shall be present to intervene in time if there is an outbreak of a fire. Examples of intervention include raising an alarm, stopping machinery or attempting to extinguish the fire.

4.4.4 Location

The extinguisher(s) shall be fitted at a safe locations and be readily accessible.

At least one fire extinguisher shall be located within the vicinity of the operator.

4.4.5 Maintenance

All fire extinguishers shall be maintained in accordance with AS 1851.

SECTION 5 FIRE PROTECTION SYSTEMS

5.1 GENERAL

Where the fire risk assessment or the authority having jurisdiction has determined the need for installation of a fire protection system, it shall be designed and installed in accordance with Section 6. For fire protection system selection, see Clause 3.5 and Figure 3.3.

5.2 FIRE PROTECTION SYSTEM FUNCTIONS

5.2.1 General

The fire protection system shall be one of the following:

- (a) Fire detection and alarm system with automatically operated suppression system.
- (b) Fire detection and alarm system with manually operated suppression system.
- (c) Manually operated fire suppression system.
- (d) Fire detection and alarm system only.

NOTE: The parts and functions of each are detailed in Figure 5.1.

5.2.2 Fire detection and alarm system with automatically operated suppression system

The fire detection and alarm system with automatically operated fire suppression system shall perform at least the following functions:

- (a) Rapidly detect a fire.
- (b) Initiate an alarm signal.
- (c) Automatically activate discharge of extinguishing agent.
- (d) Provide a means of visual indication confirming agent discharge, e.g. this could be by means of a pop up indicator or LED.

NOTE: Monitoring for a loss of pressure from a stored pressure agent container does not satisfy the requirement for confirming agent discharge.

- (e) Initiate safety functions.

All automatic fire suppression systems shall be provided with a means of manual actuation.

5.2.3 Fire detection and alarm system with manually operated fire suppression system

The fire detection and alarm system with manually operated fire suppression system shall perform at least the following functions:

- (a) Rapidly detect a fire.
- (b) Initiate an alarm signal.
- (c) Provide a means of visual indication confirming agent discharge, e.g. this could be by means of a pop up indicator, LED or observation of the discharging extinguishing agent.

NOTE: Monitoring for a loss of pressure from a stored pressure agent container does not satisfy the requirement for confirming agent discharge.

- (d) Initiate safety functions.

5.2.4 Manually operated fire suppression system

The manually operated fire suppression system shall perform at least the following functions:

- (a) Manually activate discharge of extinguishing agent.
- (b) Provide a means of visual indication, confirming agent discharge, e.g. this could be by means of a pop up indicator, LED or observation of the discharging extinguishing agent.

NOTE: Monitoring for a loss of pressure from a stored pressure agent container does not satisfy the requirement for confirming agent discharge.

5.2.5 Fire detection and alarm system only

The fire detection and alarm system shall perform at least the following functions:

- (a) Rapidly detect the outbreak of fire.
- (b) Initiate an alarm signal to allow manual safety functions.

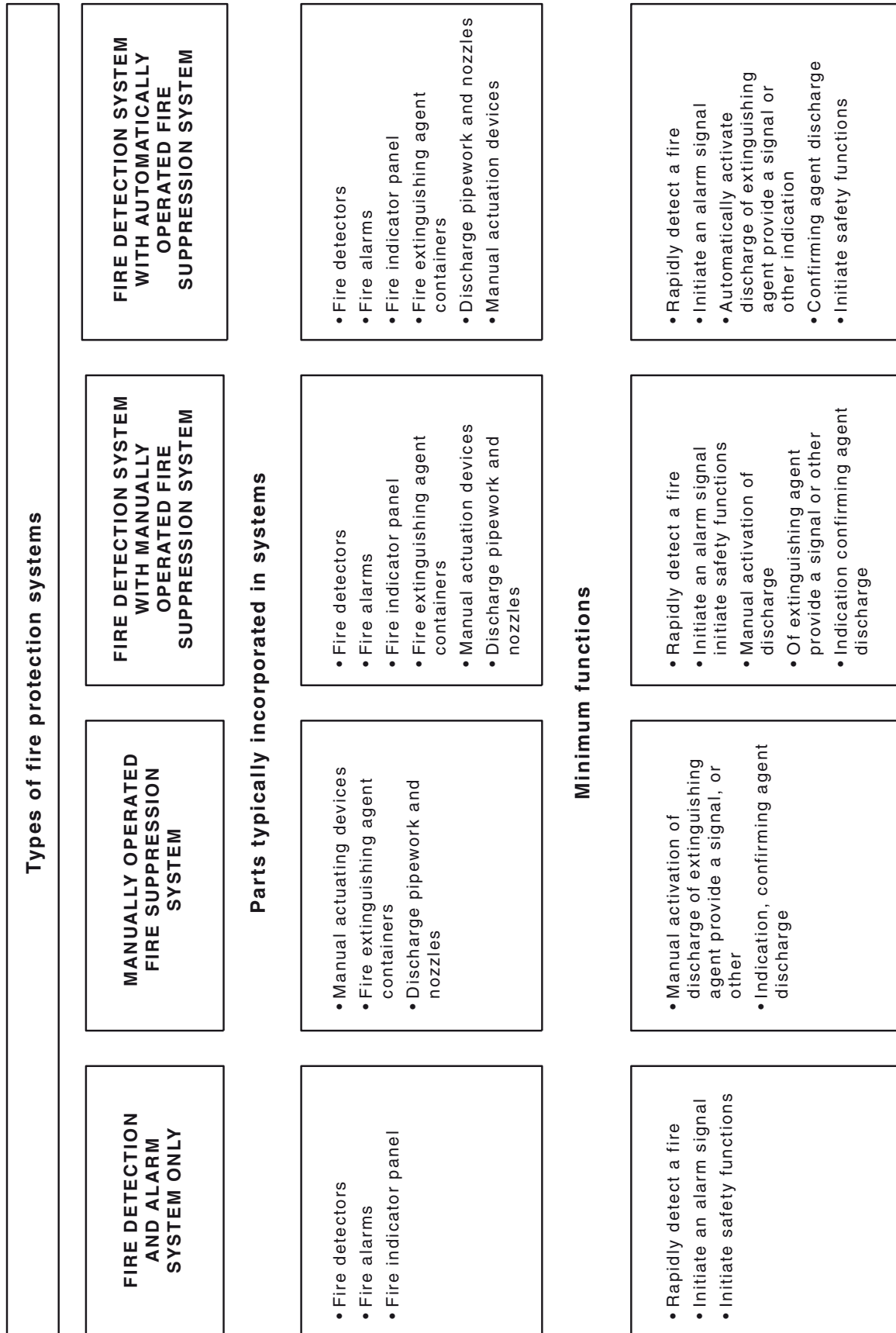

FIGURE 5.1 FIRE PROTECTION SYSTEMS

5.3 EXTINGUISHING AGENT

5.3.1 General

The type, quantity and discharge rate of the extinguishing agent shall be selected to suppress the likely fire scenarios identified in the risk assessment.

5.3.2 Selection

The selection of the appropriate fire extinguishing agent shall be made with reference to Clauses 2.4 and 3.2. Consideration shall also be given to the environmental impact of the agent and its disposal.

5.4 OPERATING CONDITIONS

Fire protection systems shall be designed with consideration for all operating conditions, including, but not limited to, the following:

- (a) Climatic conditions.
- (b) Grades and slopes.
- (c) Materials of construction.
- (d) Speeds of equipment.
- (e) Vibration.
- (f) Build-up of combustible contaminant.
- (g) Process materials.

5.5 FIRE SYSTEM SPECIFICATION

Where it has been determined that a fire system is to be installed on mobile or transportable equipment, it is essential that a detailed fire system specification be developed prior to the installation of the system. This is to ensure that the system is correctly selected, designed and configured to mitigate the identified fire risks.

The fire system specification should take into account the information gathered during and the output from, the fire risk assessment for the specific item of equipment to be protected. Consequently, the fire system specification should only be finalized after the fire risk assessment has been completed.

Preparation of a comprehensive fire system specification is an essential step to ensuring that a complete and accurate proposal for the installation of the fire system is provided to the owner. The following information is required, as a minimum, to allow the fire system to be appropriately configured:

- (a) Make, model and type of machine.
- (b) Operating environment/industry.
- (c) Identification of the risk, or risks, within the equipment to be protected.
- (d) Identification of the materials of construction in the risk or risk areas to be protected that may contribute to growth of a fire (e.g. sound suppression material and fibreglass panels).
- (e) Identification of any aftermarket devices installed, modifications, changes to structures or materials.
- (f) Power source and voltage.
- (g) Preferred (if any) extinguishing agent.
- (h) Preferred (if any) fire detection method.

- (i) Equipment shutdown requirements, including ancillary systems and shutdown delay periods.
- (j) Shutdown delay extension periods and number of permissible extension periods.
- (k) Discharge delay.
- (l) Effective discharge time.
- (m) Location and type of audible/visual alarms.
- (n) Location of manual control points.
- (o) Environmental concerns/constraints.

5.6 LISTING OF FIRE PROTECTION SYSTEMS

To meet the requirements of this Standard, all fire protection systems shall be listed (see Clause 1.4.16).

Pre-engineered systems shall be endurance and function tested in accordance with the requirements of Appendix D or equivalent test protocols approved by the testing and approval body applicable to the system.

Engineered system listing criteria shall be in accordance with the requirements of the relevant system standard.

NOTE: Where engineered system components have been subjected to testing regimes that are not equivalent to those specified in Appendix D additional testing may be required to demonstrate they are suitable for use in environments subject to severe and continuous vibration such as experienced on heavy mining machines.

C5.6 Listing of systems to component testing regimes, other than those specified in Appendices D and E does not necessarily mean that the components are fit for purpose in environments subject to severe and continuous vibration such as experienced in heavy mining machines.

Fire testing of foam water spray systems shall be in accordance with Clause 5.4. In the case of powder systems, the fire testing criteria shall be in accordance with the requirements of UL 1254.

For other pre-engineered systems, the fire testing criteria shall be determined by a listing agency to appropriately assess extinguishing and operational effectiveness.

5.7 FIRE TESTING REQUIREMENTS FOR FOAM WATER SPRAY FIRE SUPPRESSION SYSTEMS

5.7.1 General

The following tests, as detailed in Appendix E, shall be carried out to evaluate the performance of foam water spray fire suppression systems:

- (a) *Test 1* Direct application fuel spill extinguishment and reignition test.
- (b) *Test 2* Indirect application fuel spill extinguishment and reignition test.

Both tests shall be repeated for each type of fire protection system nozzle listed in the manufacturer's design manual.

5.7.2 Test 1 acceptance criteria

When tested in accordance with Appendix E, the following criteria shall be used to assess the performance of the fire protection system:

- (a) The main tray fire shall be extinguished within a period not exceeding 80% of the system's effective discharge time.

- (b) No reignition of the fire tray shall occur.
- (c) All nozzle caps shall release and shall not interfere with the discharge pattern of the nozzles.

5.7.3 Test 2 acceptance criteria

When tested in accordance with Appendix E, the following criteria shall be used to assess the performance of the fire protection system:

- (a) The main diesel tray fire shall be extinguished before the completion of the systems effective discharge time.
- (b) The diesel spray shall not reignite when restarted.
- (c) All nozzle caps shall blow off and shall not interfere with the discharge pattern of the nozzles.

5.8 DESIGN AND INSTALLATION

All fire protection equipment, including detection, warning, actuation, suppression and shutdown equipment, shall be designed and installed by competent people endorsed by the system manufacturer.

C5.8 Completion of nationally endorsed units of competency (under the Australian Qualification Framework) does not automatically guarantee the competence of an individual. It is widely recognized that, in addition to having completed relevant nationally endorsed units of competency, manufacturer or product specific training is required to ensure that an individual is competent to work on a specific product or system. Evidence of completion of both nationally endorsed units of competency and manufacturer or product specific training should be sought to confirm the competence of individuals.

Design of fire protection equipment shall be carried out in accordance with Section 6.

5.9 EQUIPMENT MODIFICATIONS

The fire protection system shall not impair the operation of the existing control systems on the equipment.

Where modifications to the existing equipment systems are required, they shall—

- (a) require a risk assessment in consultation with the equipment manufacturer;
- (b) not compromise any safety functions of the equipment; and
- (c) not increase fire risk.

5.10 DOCUMENTATION

The design of all fire protection systems shall be documented. A copy of the fire protection system documentation shall be issued to the equipment owner. In addition, the equipment owner shall document any modifications made to the equipment. The equipment owner shall maintain the records.

Records shall include, but not be limited to, the following:

- (a) Design documentation.
- (b) Commissioning and test results.
- (c) Operation and maintenance manuals.
- (d) Equipment modifications.

5.11 FIRE PROTECTION SYSTEMS

5.11.1 General

The fire protection system shall remain active in event of engine shutdown, electrical supply failure or failure of any other system.

5.11.2 Isolation of fire suppression systems

The fire protection systems manufacturer shall provide a method or procedure for isolating or preventing the accidental discharge of the system during equipment maintenance.

Isolation shall be carried out in accordance with AS 4024.1603.

5.12 SYSTEM SAFETY REQUIREMENTS

5.12.1 Electrical clearances

All fire extinguishing components shall be located so as to maintain safe minimum clearances from live parts in accordance with AS/NZS 3000 or as applicable.

5.12.2 Safety clearances

Where exposed electrical conductors are present, clearances shall be not less than those given in AS 2067.

SECTION 6 FIRE PROTECTION SYSTEM DESIGN

6.1 GENERAL

6.1.1 Design

Fire protection systems shall be designed by a competent person or under the supervision of a competent person.

6.1.2 Fire system specification

The fire protection system shall satisfy the requirements of the fire system specification.

6.2 DESIGN DOCUMENTATION

6.2.1 General

The design of the system shall be in accordance with the listed system design manual.

All system calculations shall be carried out using the method specified in the listed system design manual. The system calculations shall be in accordance with the manufacturer's listed limitations and shall be used only with components listed for that design method (see also Clause 6.3).

Design documentation shall contain sufficient detail to enable an evaluation of the effectiveness of the system to protect the hazard location(s) as determined in the risk assessment. It shall include the following:

- (a) General arrangement drawings and/or schematics and photographs showing the layout of the system and detailing the location of major components.
- (b) Details of—
 - (i) the area of coverage provided by the fire protection system design;
 - (ii) system configuration of the automatic and manual release;
 - (iii) the functional sequence of events;
 - (iv) fire protection system interface with the equipment; and
 - (v) shutdowns and time delays.
- (c) System owner's manual detailing—
 - (i) instructions for use;
 - (ii) all components and part numbers;
 - (iii) technical data sheets;
 - (iv) safety data sheets; and
 - (v) recommended maintenance practices and procedures.
- (d) Description of system operating limitations such as temperature, slope and gradient.

6.2.2 Specific design detail

The documentation specified in Clause 6.2.1 shall include the following information:

- (a) Name of owner.
- (b) Equipment identification.

- (c) Agent storage—
 - (i) number, capacity and location of agent containers;
 - (ii) quantity of agent;
 - (iii) brand and specification of agent;
 - (iv) type and size of container valve;
 - (v) storage pressure; and
 - (vi) method of agent quantity calculation.
- (d) Agent distribution—
 - (i) details of the nozzles by type, size, orifice and specific items of equipment protected by each nozzle;
 - (ii) for engineered systems, pipe sizing and flow calculations;
 - (iii) discharge time; and
 - (iv) specification of hose, tube, pipe and fittings.
- (e) Detection and control—
 - (i) type of detection;
 - (ii) specific area protected and location of detectors; and
 - (iii) single line diagram showing detection, control, and alarm circuits and shutdown interfaces.
- (f) Actuation—
 - (i) methods of automatic and manual actuation;
 - (ii) number and location of manual release points; and
 - (iii) number, capacity, and pressure of actuation cartridges.

6.2.3 Provision of design documentation

Design documentation shall be provided in accordance with the following:

- (a) *Prior to installation* The owner shall be provided with a general description of the system configuration and operation. The description shall include scope of protection, summary of major system components and any required modifications to equipment.
- (b) *When any significant change is made to the initial design* The design documentation shall be revised accordingly.
- (c) *As part of commissioning* All the documentation specified in Clauses 6.2.1 and 6.2.2 of the as-installed system shall be provided to the owner.

6.3 SYSTEM DESIGN PROCEDURES

6.3.1 General

Fire protection systems may be either engineered (see Clause 1.4.11) or pre-engineered (see Clause 1.4.23), and shall meet the requirements of Clauses 6.3.2 or 6.3.3, as applicable.

Where it is not possible to avoid the use of electrically conductive suppression agents, interlocking systems shall be used to remove electrical power prior to the discharge of the suppression system.

6.3.2 Engineered systems

6.3.2.1 General

Engineered systems shall be designed in accordance with the recognized design Standards set out in Clauses 6.3.2.2, 6.3.2.3 and 6.3.2.4.

6.3.2.2 Foam fire suppression systems

Foam fire suppression systems shall be designed in accordance with NFPA 11 and the requirements of this Standard.

NOTE: NFPA 11 specifically excludes foam/water spray systems from its scope. Engineered foam/water spray systems should be designed in accordance with NFPA 16.

Foam fire suppression systems are suitable for spaces with flammable liquids and surfaces coated with combustible materials. A typical application is for enclosed machinery spaces.

6.3.2.3 Water mist

Water mist fire suppression systems shall be designed in accordance with AS 4587 or, NFPA 750 and the requirements of this Standard.

Water mist systems are typically total flooding systems suitable for enclosed spaces where three-dimensional pressure fires, flammable liquids and surfaces coated with combustible materials are present.

NOTE: The system performance may be enhanced by the use of an additive to the water.

6.3.2.4 Gaseous agent

Gaseous agent fire suppression systems shall be designed in accordance with AS ISO 14520 and the requirements of this Standard.

Gaseous agent fire suppression systems are typically total flooding systems suitable for fully enclosed spaces. Typical applications include electrical and electronic equipment where there is a requirement for a non-conductive and clean extinguishing agent.

6.3.3 Pre-engineered systems

6.3.3.1 General

Pre-engineered systems shall be designed in accordance with the procedures detailed in the system's listed design manual. No deviation shall be permitted from the limits specified by the manufacturer and the listing body.

Pre-engineered systems shall be assessed for compliance in accordance with Clause 5.3.

6.3.3.2 Foam water spray

Foam water spray fire suppression systems shall be designed in accordance with the requirements of this Standard and the system's listed design manual.

Foam water spray fire suppression systems are local application systems which provide a high level of cooling and are suitable for unenclosed or ventilated spaces where three-dimensional pressure fires, flammable liquids and surfaces coated with combustible materials are present.

6.3.3.3 Powder

Powder fire suppression systems shall be designed in accordance with the requirements of this Standard and the system's listed design manual.

Dry powder fire suppression systems are local application systems which provide rapid fire knockdown and are suitable for unenclosed or ventilated spaces where three-dimensional pressure fires, flammable liquids and surfaces coated with combustible materials are present.

6.3.3.4 *Wet chemical*

Wet chemical fire suppression systems shall be designed in accordance with the requirements of this Standard and the system's listed design manual.

Wet chemical fire suppression systems are local application systems which provide a higher level of cooling and are suitable for unenclosed or ventilated spaces where three-dimensional pressure fires, flammable liquids and surfaces coated with combustible materials are present.

6.3.3.5 *Condensed aerosol*

Condensed aerosol systems shall be designed in accordance with the requirements of this Standard and the system's listed design manual.

NOTE: Relevant parts of AS 4487 should also be considered.

Aerosol systems are total flooding systems suitable for normally unoccupied, substantially enclosed spaces which contain flammable liquids and surfaces coated with combustible materials. A typical application is for the protection of enclosed machinery spaces.

6.3.3.6 *Dual agent*

Dual agent fire suppression systems shall be designed in accordance with the standards relevant for the agents employed (e.g. NFPA 17 for dry chemical powder and NFPA 17A for wet chemical) and the system's listed design manual.

Dual agent fire suppression systems are typically powder local application systems combined with a liquid-based cooling system. They provide rapid fire knockdown followed by cooling of identified high temperature reignition sources.

6.4 QUANTITY OF AGENT

6.4.1 General

The quantity of extinguishing agent shall be, as a minimum, the quantity required to satisfy the extent of protection determined from the risk assessment and the requirements of the relevant design Standard or, for pre-engineered systems, the listed design manual.

6.4.2 Special conditions

Additional quantities of extinguishing agent may be required to compensate for any special conditions that would adversely affect the protection efficiency. The design quantity of extinguishing agent shall be adjusted to compensate for—

- (a) non-closable openings;
- (b) forced ventilation;
- (c) the free air volume of air receivers that may discharge into the protected area;
- (d) altitude (substantially above or below sea level);
- (e) delayed plant shutdown; and
- (f) other circumstances requiring agent quantity adjustment.

6.5 EQUIPMENT SHUTDOWN

Any equipment system such as electrical power supply, fuel and hydraulic system valves and pumps, which if left running could impair the efficiency of the fire protection system, shall be shut down upon system discharge unless otherwise required for safety. In such cases, an extended discharge and time delay on the equipment system shutdown shall be considered.

6.6 AIR HANDLING

Air-handling systems should be shut down prior to system discharge.

Where it is necessary for air-handling systems serving the protected area to be kept operating, consideration shall be given to extinguishing agent quantities, discharge rates and nozzle location and orientation to maintain the effective fire extinguishing performance.

C6.6 High airflows associated with air handling systems may impair fire system effectiveness. High airflows can affect extinguishing agent discharge nozzle distribution patterns and cause excessive loss of extinguishing agent from the protected area.

6.7 DISCHARGE TIME

System discharge time shall be determined by the risk assessment and in no case, shall be—

- (a) for engineered systems, less than that required by the relevant design Standard; and
- (b) for pre-engineered systems, less than that required by their listing.

Where equipment cannot be immediately shut down, consideration shall be given to providing additional agent for an extended discharge, or sequenced discharge of the system or, where necessary, by delaying the system discharge.

C6.7 The primary consideration for extended discharge is to maintain the extinguishing performance of the system while the equipment is brought to rest or safely shut down, and permit safe egress of personnel.

Extended discharge may also be required where accumulators or other stored pressure fuel sources could continue to provide a supply of fuel to the fire.

6.8 SYSTEM FLOW CALCULATIONS

System flow calculations for engineered systems shall be in accordance with the manufacturer's design manual.

6.9 CONTAINMENT OF EXTINGUISHING AGENT

For total flooding fire suppression systems, openings in the fire hazard location shall be kept to a minimum.

6.10 IDENTIFICATION OF DISCHARGE NOZZLES

Discharge nozzles shall be permanently marked to identify the type, and the size of nozzle and, where applicable, the orifice size. The markings shall be discernible after installation.

SECTION 7 SUPPLY

7.1 STORAGE CONTAINERS

7.1.1 General

Containers shall be designed and approved to hold the specific extinguishing agent and shall be of a suitable material to resist environmental conditions such as corrosion. Containers shall not be charged to a fill-density greater than specified by the manufacturer.

7.1.2 Pressurized containers

Pressurized containers shall comply with the requirements of AS 2030 or AS 1210 as appropriate. Container valves shall comply with AS 2473.1.

NOTE: The requirements of appropriate authorities for containers may take precedence over the requirements of this Standard, e.g. in marine or aviation industries. Accordingly, the authority having jurisdiction should be contacted for advice.

All pressurized container assemblies, including those classified as accumulators, with a hazard classification other than E (based on pressure × volume) as specified in AS 4343, shall be fitted with a pressure relief device which complies with AS 2613.

7.1.3 Pressure indication

Pressurized agent storage containers shall be fitted with a pressure indicator to indicate that each container is correctly charged.

A pressure switch shall be fitted to monitor agent container pressure.

NOTE: Pressure monitoring switches do not need to be fitted to storage containers in manually operated systems that do not incorporate an automatic fire detection and alarm or control system.

7.1.4 Pressurized container transport and storage

During transport and storage of pressurized container assemblies, the container valves shall be fitted with outlet and actuator port caps, plugs, locking devices or other means to prevent accidental discharge. All such outlet and actuation caps, plugs and locking devices shall be removed prior to commissioning the system.

7.2 STORAGE CONTAINER ARRANGEMENT

7.2.1 General

Storage containers shall be installed in accordance with the limitations detailed in the manufacturer's listed manual.

7.2.2 Location and mounting

The location of storage containers and accessories shall be as follows:

- (a) Containers and accessories shall be located and arranged so that inspection, testing, recharging and other maintenance are facilitated, and interruption to protection is kept to a minimum.
- (b) Where practicable, containers shall not be subject to severe weather conditions or to mechanical, chemical or other damage. Where excessive climatic or mechanical exposures are expected, suitable guards or enclosures shall be provided.

NOTE: Containers should be located outside the protected space and as near as practical to the fire hazard location they protect.

- (c) Container brackets or devices that are integral to the container and used for attachment to structures shall be designed to cater for the maximum expected mass, vibration effects and shock loading of the installation.

- (d) If provided, reserve containers shall be permanently connected or arranged for easy changeover.

NOTE: Reserve extinguishing agent supplies may be required where significant reflash potential exists or where continuity of operation is essential.

- (e) Each container shall be marked in accordance with Clause 7.3.

7.2.3 Agent storage container orientation

Containers shall be installed within the container limitations imposed by the listing, such that they will correctly operate and discharge the required quantity of agent under the normal operating conditions of the equipment.

C7.2.3 Fire protection systems are designed to operate when the storage containers are upright or within their listed orientation limits. Incomplete discharge of extinguishing agent could occur if the containers are installed or the equipment is operated outside these limits. In cases of vehicle rollover, operation of the fire protection system may be severely compromised due to incomplete discharge of agent.

7.3 IDENTIFICATION, MARKING AND LABELLING OF CONTAINERS

7.3.1 Colour identification

Containers for water, foam, wet chemical and powder shall be coloured for identification in accordance with AS/NZS 1841.1.

Containers for other extinguishing agents shall be coloured for identification in accordance with the applicable design Standards.

7.3.2 Permanent markings

Each container shall be permanently marked in accordance with AS 2030.1 or AS 1210, or other internationally accepted Standards.

7.3.3 Labelling

The following information shall be displayed on the container by means of painting or durable labels in black lettering not less than 3 mm high on a white background:

- (a) Manufacturer's or distributor's name or trademark and contact details.
- (b) Part number, description and type of extinguishing agent.
- (c) Mass or volume of extinguishing agent.
- (d) Refill instructions.
- (e) Charge pressure and temperature of the container.
- (f) Any other cautionary safety, environmental or disposal statement required.

NOTE: Figure 7.1 shows an example of a typical container label.

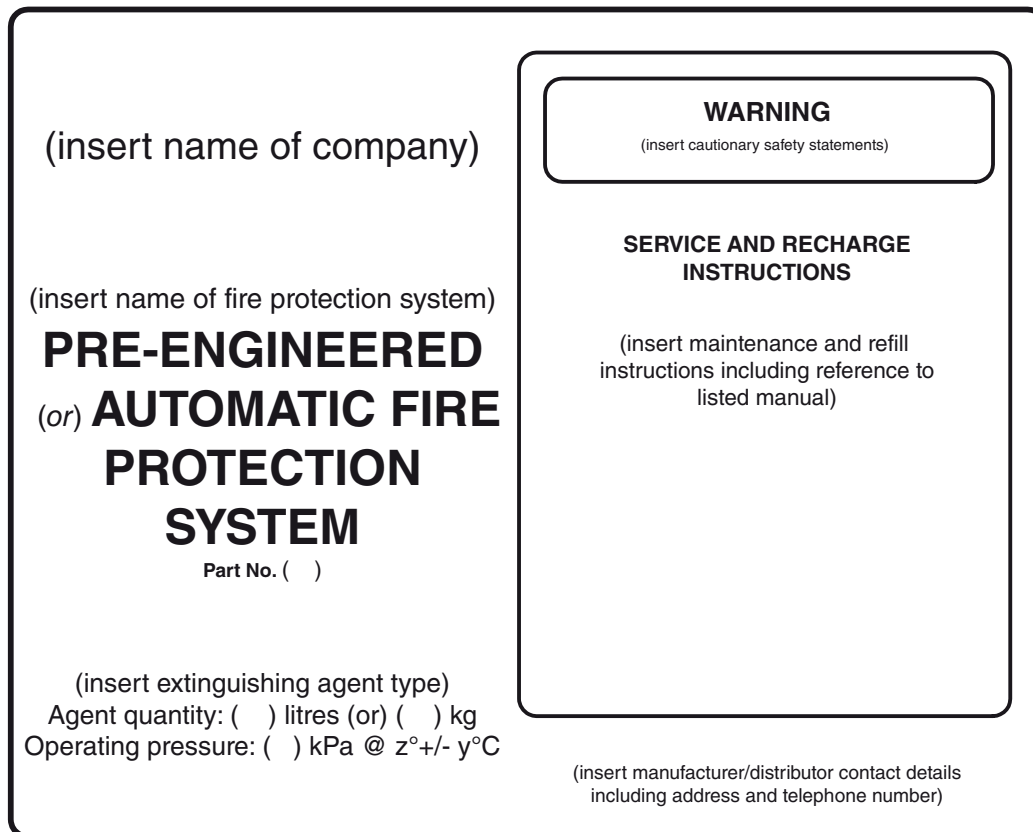

FIGURE 7.1 EXAMPLE OF A CONTAINER LABEL

7.4 FIRE PROTECTION SYSTEM CONTROL VALVES

7.4.1 General

All valves shall be used only in conditions for which they are listed and shall be rated for operation at not less than the container pressure at the maximum temperature anticipated.

Valves shall be protected against mechanical, chemical and other damage.

7.4.2 Isolating valves

Isolating valves, other than container, directional or lock-off valves, shall not be installed between containers and nozzles.

Where it is demonstrated to the authority having jurisdiction that additional isolating valves are required, such valves shall be monitored for a change in their open or closed position.

SECTION 8 DISTRIBUTION SYSTEM

8.1 GENERAL

The size and arrangement of distribution systems including hose lengths, nozzle and fitting orientation shall be in accordance with the listed design manual.

Distribution hoses shall meet MSHA Schedule 2G flame resistance requirements. The working pressure of all shall be at least equal to the maximum developed container pressure at 65°C.

NOTE: MSHA is the United States Department of Labour, Mine Safety and Health Administration.

8.2 DISTRIBUTION SYSTEM SUPPORTS

The distribution system supports shall—

- (a) be of robust construction to suit the intended application;
- (b) retain the distribution system in position during a fire;
- (c) be suitable for the expected temperature;
- (d) withstand the dynamic and static forces involved; and
- (e) be protected against corrosion.

8.3 COMPATIBILITY

Distribution system components shall be compatible with each other and the extinguishing agent.

8.4 INSTALLATION OF DISTRIBUTION SYSTEM

8.4.1 General

Penetrations of bulkheads that separate fire compartments shall be bushed and sealed, and shall utilize approved fittings or approved fire-retardant material to reduce fire spread to other areas.

8.4.2 Flow restrictions

The distribution system shall be installed to avoid possible flow restrictions due to foreign matter, faulty fabrication or improper installation. Pipe, tube and hose-ends shall be reamed after cutting.

The distribution system shall be cleaned before assembly and free of particulate matter or oil residue before the installation of nozzles or discharge devices.

NOTE: Appendix C provides examples of good practice for the installation of for distribution systems.

8.5 NOZZLES

8.5.1 General

Nozzles shall be made of metallic, corrosion resistant materials that will not deform or otherwise be damaged by fire exposure or discharge pressure. Nozzles shall be fitted with nozzle caps to prevent ingress of particles unless otherwise determined from the risk assessment. Nozzle caps shall be suitable for the ambient operating temperatures. The listing for nozzle caps shall include demonstration that the nozzle performance is not impaired by the effects of fire or thermal degradation.

8.5.2 Nozzle choice and location

Location of system nozzles shall be selected in accordance with their system design manual to provide protection to the areas identified in the risk assessment.

Nozzle discharge shall not unduly splash flammable liquids or create dust clouds, either of which may extend the fire, create an explosion or otherwise adversely affect the occupants.

Nozzles shall be connected and supported so that they will not readily be moved out of alignment and, as far as practicable, do not interfere with normal operation and maintenance of the equipment.

SECTION 9 FIRE DETECTION, ACTUATION AND CONTROL SYSTEMS

9.1 GENERAL

For engineered systems, the detection, control and actuation shall be designed in accordance with the design Standards set out in Clauses 6.3.2.2, 6.3.2.3 and 6.3.2.4.

For pre-engineered systems, the detection, control and actuation shall be in accordance with this Section.

Detection, actuation and control systems may be either automatic or manual. Where they are automatic, provision shall also be made for manual operation.

NOTE: Automatic fire suppression should provide for automatic engine shutdown on detection of a fire.

Only system components that are listed as part of the system shall be used to initiate audible or visual warning, automatic actuation of a fire suppression system, or equipment shutdown.

Detection, actuation and control systems shall comply with the following:

- (a) The type of detection device used shall be appropriate to the specific hazards identified in the risk assessment.
- (b) Location of detection devices shall be in accordance with the fire risk assessment and the manufacturer's listed design manual.
- (c) All detection systems other than those that fail to safety shall be supervised, unless the detection circuits are duplicated on physically separate paths. The fire protection system wiring, hoses or tubing shall be protected from mechanical damage and secured using the same clamping methods used by the original equipment manufacturer or approved equivalent.

NOTE: The use of cable ties should be avoided.

- (d) Design of actuation and control systems shall include the following:
 - (i) Interface with equipment systems, e.g. engine shutdown systems and emergency braking systems. The connection shall be in accordance with the protected equipment manufacturer's recommendations.
 - (ii) Means of indicating that the fire protection system is disabled.

9.2 MANUAL ACTUATION

Manual actuation points shall be located as determined by a risk assessment and in accordance with the fire system specification. At least one manual actuation point shall be within reach and clearly visible from the operator's normal operating position. They shall be—

- (a) coloured red;
- (b) readily accessible; and
- (c) identified in accordance with Clause 4.3.4.

Additional manual actuation points should be provided—

- (i) adjacent to normal egress paths;
- (ii) accessible from ground level where practicable; and
- (iii) adjacent to equipment emergency stop points.

Operation shall cause actuation of all valves, other than lock-off devices, required for extinguishing agent discharge.

A means of mechanical manual actuation shall be provided unless the power supply for the control and indicating equipment complies with the requirements of Clause 9.6.3.2. In such cases electrical manual operation is acceptable without the need for an additional mechanical means of actuation.

Manual mechanical releases shall incorporate a two-step action or other safety feature to restrict accidental operation. Manual releases shall require less than 180 N of force and less than 360 mm of movement to operate.

9.3 ELECTRICAL SYSTEMS

Electrical equipment enclosures including junction boxes shall be of robust construction, and unless otherwise protected from exposure to adverse environmental conditions, be rated to IP65 in accordance with AS 60529.

Consideration shall be given to the effects of electromagnetic interference (EMI) which may cause false triggering or alarming of the system, or prevent operation of the system.

All cables and enclosures located in areas likely to be subjected to a fire shall be suitably rated to withstand the effects of heat for a period of time long enough to allow for reliable operation of the fire system.

In areas where EMI causes false operation of the system, cabling systems shall be installed in enclosures that provide effective shielding, or alternatively, cables that minimize susceptibility to EMI may be used.

9.4 PNEUMATIC SYSTEMS

Pneumatic systems shall comply with the following:

- (a) Pneumatic lines shall be located to protect against accidental crimping and mechanical damage.
- (b) Pneumatic detection lines shall be configured so that condensation does not accumulate in the actuation device.
NOTE: Condensation in the actuation device may cause corrosion and inhibit its operation.
- (c) Means shall be provided to safely release trapped pressure from any pressurized component or pipework.
- (d) Pneumatic actuation systems shall be operated by pressure from a reliable stored source. Stored pressure from the extinguishing agent's main storage container or a separate pilot container may be used as a source of energy for system release.
- (e) Rise of pressure style manual pneumatic actuation points shall be provided with a means of continuous pressure indication, unless additional actuation points are provided, each with its own source of stored pressure.

NOTE: Pneumatic lines for rise of pressure style systems should be so arranged that failure of any one line will not prevent the system operating when initiated from another activation point.

9.5 MECHANICAL SYSTEMS

Where mechanical fire detection and control equipment such as fusible links or manual release lines are used, all cables shall be run within protective tubes with free-turning corner pulleys at all changes of direction, unless otherwise permitted by the systems listed design manual.

Automatic mechanical releases shall be capable of being tested for proper operation. Where fusible links are used, they shall comply with AS 1890.

9.6 CONTROL AND INDICATING EQUIPMENT

9.6.1 General

Control and indicating equipment shall be EMC (Electro-Magnetic Compatibility) tested to the relevant parts of AS/NZS 61000.6.2 and AS/NZS 61000.6.4 or ISO 13766. Control and indicating systems shall comply with Clauses 9.6.4 to 9.6.10.

9.6.2 System status indication panel

System status indication shall be fitted to all automatic fire protection systems that rely solely upon pneumatic or mechanical detection or actuation of the fire protection system and shall provide indication for the following conditions:

- (a) *System fault*—which shall consist of an amber indication and intermittent audible alarm.
- (b) *System discharge*—which shall consist of a latching red indication and continuous audible alarm.
- (c) *Power on*—which shall consist of a green indication.
- (d) *Indicators and controls for optional functions.*

NOTE: As system status indication panels do not provide any control functions, they do not require a secondary power supply.

9.6.3 System control and indicator panel

9.6.3.1 General

A system control and indicator panel shall be fitted to all fire protection systems that rely on electrical detection or actuation of the fire protection system.

All electrical detection and actuation circuits external to the panel shall be supervised.

The system control and indicator panel shall comply with the following—

- (a) It shall be rated to IP65 in accordance with AS 60529, unless otherwise protected from exposure to adverse environmental conditions.
- (b) It shall be located at the operator's station and be visible and accessible during normal operating conditions. In cases where it is not practicable to locate the system control and indicator panel at the operator's station, all indicators and controls specified in Item (d) shall be repeated at the operator's station.
- (c) It shall be provided with—
 - (i) equipment shutdown output;
 - (ii) alarm/fault sounder; and
 - (iii) system isolate and reset function operable only through the use of tools, key or password.

NOTE: Use of single key press (held for a period not less than 5 s) or depressing a combination of keys on the control and indicator panel are acceptable means of providing a password for this function.

- (d) It shall be provided with the following indications:
 - (i) *Power-on*—Green.
 - (ii) *Fire alarm*—Latching red visual and continual audible.

- (iii) *Fault*—Latching amber visual and intermittent audible.
NOTE: This indication need not latch if it is otherwise logged.
- (iv) *System isolated*—Amber visual and intermittent audible.
- (v) *System discharge*—Latching red visual and continuous audible. An indication that a signal has been sent to initiate the extinguishing agent discharge device does not satisfy this requirement.
- (vi) *Indicators and controls for optional functions*

9.6.3.2 Power supply

Unless otherwise listed, power for fire protection system control indication panels shall be provided from at least two separate power supplies, as follows:

- (a) The primary power supply shall be of sufficient capacity to independently provide power for all system functions when the equipment is running.
- (b) The secondary power supply shall be capable of supplying sufficient power to operate all system functions required by this Standard after a standby period of 24 h.

The secondary power supply shall be supervised and generate a fault condition when no longer able to meet this requirement.

When the suppression system is designed for the possible simultaneous protection of multiple enclosures, the power supplies shall be calculated to satisfy the maximum simultaneous demand.

Loss of primary electric power shall not prevent the manual operation of the fire suppression system.

Where the fire system primary power supply is sourced from the equipment power supply it shall be connected directly to the equipment power supply. If an isolator is fitted, it shall be separate from the main electrical isolator for the equipment.

9.6.4 Marking

All indicators and controls shall be permanently labelled with their actual function name or a readily recognizable abbreviation.

All control and indicating equipment that is connected to a mains power supply shall comply with the marking requirements of AS/NZS 3100.

Control and indicating equipment shall have the following information permanently marked on it:

- (a) Name of manufacturer.
- (b) Drawing/serial number.
- (c) Year of manufacture.

9.6.5 Engine shutdown

Where engine shutdown facility is fitted, the control and indicator panel or status panel shall be provided with a red visual indication of shutdown output.

9.6.6 Engine shutdown time delay—Optional function

Time delay may be provided to enable the equipment to be brought to a safe condition. A delay extension may be provided to allow the operator to extend the shutdown delay. The time delay and delay extension periods shall be determined as part of the risk assessment in accordance with Section 3.

Before the end of the time delay period the audible alarm indication shall change to a rapid intermittent signal to alert the operator that the shutdown delay period is nearly expired.

9.6.7 Engine shutdown override—Optional function

An engine shutdown override may be provided to enable the equipment to be temporarily energized for safety or maintenance purposes. The engine shutdown override shall be operable only through the use of tools, key or password.

NOTE: Use of single key press (held for a period not less than 5 s) or depressing a combination of keys on the control and indicator panel are acceptable means of providing a password for this function.

9.6.8 Audible indication

Audible indication shall be at least 85 dB(A) at a distance of 1 m.

NOTE: In relatively quiet operating environments a lower sound pressure level may be required to comply with regulatory requirements. In such cases the volume of audible indication may be reduced after having completed a risk assessment.

Intermittent audible indication shall be for a minimum of 1 s/min.

9.6.9 Visual indication

The on-off state of visual indicators shall be discernible within the range of ambient illumination of 0–3000 lx.

9.6.10 Container pressure switch input

For systems using stored pressure containers, a pressure switch input shall be provided to allow monitoring of agent container pressure.

NOTE: On systems using loss of pressure actuation and where the pressure in the actuation system is provided from the agent storage containers, the container pressure monitoring switch may be installed in the actuation circuit.

SECTION 10 COMMISSIONING AND ACCEPTANCE OF FIRE PROTECTION SYSTEM

10.1 GENERAL

The fire protection system shall be commissioned in accordance with the manufacturer's listed system manuals.

The commissioning procedures shall demonstrate system integrity, functionality and compliance with system design documentation.

Engineered systems shall be commissioned in accordance with the relevant design Standard (see Clause 6.3) and the manufacturer's requirements.

10.2 DISCHARGE TEST

10.2.1 General

Fire suppression systems shall be discharge tested as part of the commissioning procedure unless otherwise accepted by the authority having jurisdiction. Any agent discharge shall be managed in accordance with local environmental requirements.

The discharge test shall be used to confirm discharge performance, including the following:

- (a) Discharge time.
- (b) Nozzle coverage criteria.
- (c) Release of nozzle caps.
- (d) Free passage and integrity of pipework system.
- (e) Full system functionality.

Simulant agents may be used for discharge testing. For example, for pre-engineered systems, potable water is considered an acceptable simulant for aqueous-based extinguishing agents.

For engineered systems, reference shall be made to the relevant design Standard.

For powder systems, the entire distribution network, including nozzles and nozzle caps, shall be purged with dry air or nitrogen to prove free passage in lieu of a discharge test.

For condensed aerosol systems, full functional testing of the actuation system may be completed in lieu of a discharge test. For electrically actuated condensed aerosol systems, test devices shall be connected in place of the condensed aerosol generators and the actuation circuit tested to ensure the required current and voltage is delivered to operate each of the condensed aerosol generators.

NOTE: Condensed aerosol generators are non-rechargeable.

C10.2.1 *It is generally accepted that a full discharge test demonstrates all aspects of system performance.*

10.2.2 Reporting

The following shall be recorded and reported as part of the discharge test:

- (a) Effective discharge time.
- (b) Confirmation of nozzle coverage of selected hazards.
- (c) Equipment shutdown delay time and sequence (if fitted).
- (d) Date of commissioning test.

- (e) Any deficiencies in the system design.

Additional documentation such as photographs may be provided as part of the report.

NOTE: A typical commissioning report for pre-engineered systems is provided in Appendix F.

10.3 SYSTEM FUNCTION AND OPERATION TEST

The correct operation of all system components, including the following, if fitted, shall be confirmed:

- (a) Fire detection and alarm system.
- (b) Audible and visual fire detection and discharge alarms.
- (c) Visual evacuation and warning devices.
- (d) Equipment shutdown.
- (e) Equipment shutdown delay.
- (f) Discharge time delay.
- (g) Directional valves.
- (h) Container release actuators.
- (i) Manual release devices.
- (j) Pneumatic equipment.

10.4 COMPLETION REPORT AND DOCUMENTATION

The installer shall provide a certification package consisting of the following:

- (a) *Commissioning report* For engineered systems, the commissioning report from the respective engineered system Standard shall be used (see Clause 6.3.2).
- (b) *Certificate of completion* As a minimum, the following information shall be included:
 - (i) Hazard areas or items of equipment protected.
 - (ii) Location, number and capacity of agent containers.
 - (iii) Quantity of agent and pressure of each container.
 - (iv) Location, type and aiming point of each discharge nozzle.
 - (v) Location and type of fire detectors (if fitted).
 - (vi) Location and type of manual system actuators.
 - (vii) Location of audible and visual detection and discharge alarms.
 - (viii) Location and purpose of audible and visual warning devices.
 - (ix) Location and purpose of system labels.
 - (x) Fire system interface, shutdowns and time delays.

NOTE: A typical certificate of completion is provided in Appendix G.
- (c) *Complete set of operating instructions* Operating instructions shall include as-installed drawings, schematics and/or pictures.

10.5 OPERATION AND MAINTENANCE MANUALS

Operation and maintenance manuals shall be provided to the owner and shall include the following:

- (a) Documentation in accordance with Clause 6.2.
- (b) Functional description of the system.
- (c) Inspection and testing schedules to maintain system functionality.
- (d) Identification of risks associated with the operation and maintenance of the fire protection system.
- (e) Operation and maintenance procedures.
- (f) Safe work procedures.
- (g) Replacement intervals.
- (h) Parts listing.

10.6 TRAINING

All personnel shall be trained in the correct operation of the fire suppression system.

NOTE: Operator refresher courses should be conducted on a regular basis.

SECTION 11 SERVICE OF FIRE PROTECTION SYSTEMS

11.1 GENERAL

A service program shall be carried out in accordance with this Section. As a minimum, the requirements set out in Tables 11.1, 11.2, 11.3 and 11.4 shall be followed. Any additional service procedures detailed in the fire protection system manufacturer's listed manual shall also be followed. The service program is to provide a means to—

- (a) continuously preserve the function and performance of fire protection systems and equipment; and
- (b) demonstrate that fire protection systems and equipment interfaces function and are capable of performing to a standard not less than that to which they were originally designed.

Clause 10.5 sets out the requirements for maintenance manuals.

11.2 SERVICE PERSONNEL

Service of fire protection systems, including daily operator inspections, shall be performed by a competent person.

C11.2 Completion of nationally endorsed units of competency (under the Australian Qualification Framework) does not automatically guarantee the competence of an individual. It is widely recognized that, in addition to having completed relevant nationally endorsed units of competency, manufacturer or product specific training or access to manufacturer maintenance documentation is required to ensure that an individual is competent to maintain a specific product or system. Evidence of completion of both nationally endorsed units of competency and manufacturer or product specific training or access to manufacturer maintenance documentation should be sought to confirm the competence of individuals.

NOTE: The competent person should be accredited to the level required for the service being conducted.

11.3 RECORDS

11.3.1 General

Records shall be retained by the owner and shall include the following details:

- (a) Service activities.
- (b) Defects.
- (c) Rectifications and by whom.
- (d) Date conducted.
- (e) Baseline data. Typical base line data includes but is not limited to the following:
 - (i) System interface matrix.
 - (ii) System discharge sequence logic including alarms, time delays and equipment shutdowns.
 - (iii) Enclosure volumes (gross and net) for total flooding systems or, alternatively, dimensions of protected surfaces for local application systems.
 - (iv) Agent type.

- (v) Design concentration of application density.
- (vi) Nominal mass of extinguishing agent.
- (vii) Number of containers.
- (viii) Nominal charge pressure of storage containers.
- (ix) Container hydrostatic test date.
- (x) Pressure settings of relief valves.
- (xi) Number and location of actuators.
- (xii) Number, location and aiming points of nozzles.
- (xiii) Type of detection, if fitted.
- (xiv) Date of initial installation and service life of all items that have a defined service life.

11.3.2 Service tag or label

A service tag or label should be provided for each fire protection system to record the last level of inspection, test and survey performed.

Where a service tag is used, it shall be attached such that the force necessary to detach the tag is not less than 200 N.

Service tags shall comply with the following:

- (a) Provide for year and month.
- (b) Be made of a suitable material.
- (c) Have lettering, figures, and lines on the tag printed in black.
- (d) Have a continuous background colour approximating Golden Yellow (Y14 of AS 2700).

Service labels shall comply with Items (a), (c) and (d) above, and be manufactured from a durable adhesive material.

The tag or label shall not carry any information other than that shown in Figure 11.1 and the recorded information specified in this Clause.

The level of service carried out shall be etched, embossed stamped, or indelibly marked on the tag or label in the box corresponding to the year and month in which the routine was performed, with a figure representing the routine as follows:

A1

Punches hole	=	commissioned/placed in-service
1	=	Six-monthly
2	=	Yearly
4	=	Five-yearly
5	=	Recharge after use

The figures shall be not less than 3 mm high, and the markings shall be such that the figures are legible.

When a new service label is provided, the label shall be applied adjacent to the completed label so that the previous service history is not obscured.

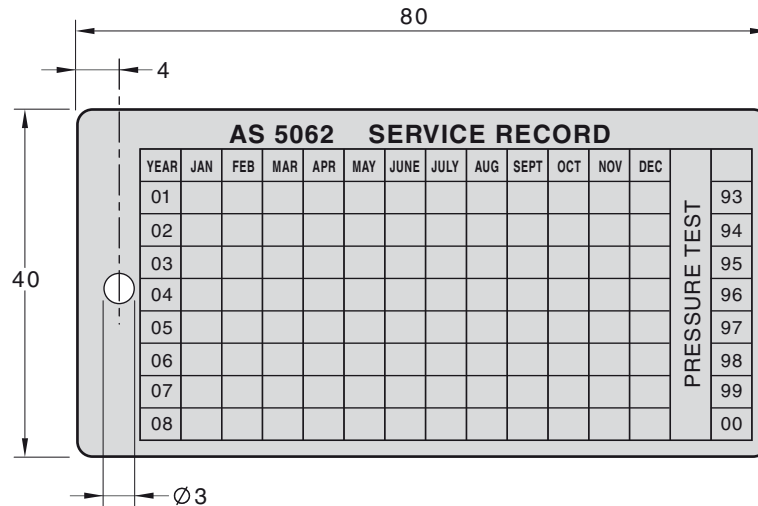

FIGURE 11.1 SERVICE TAG

11.4 PRECAUTIONS

Prior to commencing any service activity, the following precautions shall be carried out as applicable:

- (a) Inform the owner or agent that service is to be carried out.
- (b) Disable the system to prevent testing or other service activities from causing discharge of any extinguishing agent.
- (c) Set the detection and alarm system in the appropriate test mode and isolate ancillary facilities, systems and air-handling plant, where they are not to be tested.

On completion of any service, the system shall be restored to its normal operating condition.

11.5 RECHARGE OF EXTINGUISHING AGENT

Only the extinguishing agent detailed in the fire protection system listing shall be used to recharge the system.

For aqueous systems only potable water shall be used for recharge, unless otherwise detailed in the listing.

In some areas, the water supply, while fit for human consumption, may be unsatisfactory for prolonged contact under pressure with water-type containers (which are typically welded 304 stainless steel). In such areas, either specifically treated containers shall be used, or a corrosion inhibitor should be added to each charge in the container.

NOTE: Adelaide and Perth are examples of such areas where this is likely. Detailed advice on what treatment might be appropriate should be sought from container manufacturers.

If in any doubt as to the water quality, an inhibitor should be added. Failure to do so sometimes results in rapid deterioration of the container, leading to leakage or failure to operate.

The maximum periodicity of maintenance should be reduced where the use of hard water, in places where the use of hard water has proven to be a problem, or is likely to be a problem, or where salts or likely to be deposited in containers or other system components.

The presence of salts in containers can clog the pressure indicator filter, bind the actuation mechanism, inhibit the removal of the operating head or lead to corrosion.

11.6 SERVICE REQUIREMENTS

11.6.1 General

Pre-engineered fire protection systems service shall be in accordance with the manufacturer's recommendations and shall be no less than specified in Tables 11.1, 11.2, 11.3 and 11.4.

For engineered systems, service shall be carried out in accordance with the requirements of AS 1851, with the exception that the frequency of routines shall be varied where necessary to suit the conditions under which the system has been installed.

NOTES:

- 1 The scheduled frequencies are based on a single work shift under moderate operating conditions. In adverse conditions or continuous operation, consideration should be given to increasing the frequency of inspection, test, maintenance and design survey, e.g. the yearly schedule may need to be carried out six-monthly.
- 2 Adverse conditions include corrosive atmospheres, salt spray, exposure to extremes of temperature, abnormally high humidity, and vibrations.

11.6.2 Defects

Critical defects shall be rectified with the minimum of delay and before the mobile or transportable equipment is operated. Critical defects shall be reported to the responsible entity and confirmed in writing within 24 h.

Unless alternative risk reduction measures are implemented for the safety of personnel, equipment shall not be operated until the critical defects are rectified.

NOTE: An 'out-of-service' tag system should be used to indicate that the system is temporarily impaired. Tags should be attached to the affected equipment for the duration of the impairment.

Non-critical defects shall be rectified as soon as practicable and reported to the responsible entity.

Non-conformances should be rectified prior to the next yearly condition report.

11.6.3 Design survey

The design survey together with the inspection, test and preventive maintenance regime demonstrates that the fire protection systems or equipment are functional and capable of performing to a standard not less than that to which they were originally designed.

The design survey shall be undertaken to determine whether—

- (a) the system will perform as it is intended to the design at the time of commissioning or recommissioning;
- (b) scheduled maintenance has been carried out; and
- (c) neither the fire protection system nor the equipment being protected has changed from the system documentation for example, obstructions to nozzles or fire protection system component changes (see Clauses 5.8, 5.9 and 6.2.3).

The design survey shall include a check against the baseline data, including the approved design for alterations, changes in use or operating environment, or other factors that could adversely affect the performance of the fire protection system.

11.6.4 Condition report

A system condition report shall be completed on an annual basis and shall be submitted to the equipment owner within one month of the scheduled annual maintenance being performed.

The system condition report shall contain the results of all procedures included in Tables 11.3, 11.4 and 11.5.

NOTE: An example of an annual system condition report is shown in Appendix H.

11.7 ROUTINE SERVICE SCHEDULES FOR PRE-ENGINEERED SYSTEMS

Routine service of fire suppression systems shall be carried out in accordance with Tables 11.2 to 11.5

NOTE: Where the system manufacturer specifies more frequent service routines than those specified in Tables 11.2 to 11.5 the manufacturer's frequencies shall apply.

The tolerances which apply to the service activity frequencies are listed in Table 11.1. These tolerances shall be applied to the scheduled date of the initial activity.

TABLE 11.1
SERVICE FREQUENCY TOLERANCES

Frequency	Tolerance
Six-monthly	±1 month
Yearly	±2 months
Five-yearly	±3 months

TABLE 11.2
DAILY ROUTINE SERVICE SCHEDULE*

Item No.	Item	Action required and pass/fail requirement	Results	Pass/fail	Comments
1.1	Storage container pressure	Check all container pressure indicators are visible and read within normal range. (Operable range shall be no less than 90% of nominal charge pressure.) Where there is no container pressure indicator, check that the system discharge indicator has not operated.			
1.2	Manual actuators	(a) Check that all release anti-tamper seals/pull pins are in place and secure.			
		(b) Check that all actuators are secure, clean, undamaged and accessible.			
1.3	System control and indicating equipment where fitted (see Clause 9.6)	(a) Check that all indicators show normal condition.			
		(b) Check that all panels are secure, clean, undamaged and accessible.			

* The daily inspection is normally carried out by the operator prior to equipment start-up, shift-change or operator change and may be recorded by a single entry.

TABLE 11.3
SIX-MONTHLY ROUTINE SERVICE SCHEDULE

Item No.	Item	Action required and pass/fail requirement	Results	Pass/fail	Comments
2.1	Daily service	Complete all daily routine service activities listed in Table 11.2			
2.2	Distribution system	(a) Check nozzle caps are in place, if not, clean nozzle and replace caps.			
		(b) Check nozzles are pointing at pre-determined aiming points.			
		(c) Check distribution system, (hoses, tube, fittings and supports) are intact and not damaged.			
2.3	Actuation system	(a) Pneumatic actuation system (if fitted)—Check hoses, tube, fittings and supports are intact and not damaged.			
		(b) Electric actuation system (if fitted)—Check wiring, connections and supports are intact and not damaged.			
2.4	Detection system	(a) Pneumatic detection system (if fitted)—Check detection hoses, tube, fittings and supports are intact and not damaged and are in position.			
		(b) Electric detection system (if fitted)—Check detectors, wiring, connection and supports are in intact, not damaged and detectors are in position.			
2.5	Labels	Check manual release, system warning and instruction labels are securely in place, visible and legible.			
2.6	Storage containers	(a) Check storage containers and valves are not damaged.			
		(b) Check storage container and mounting bracket are secure.			
		(c) Check storage container label is securely in place, visible and legible.			
2.7	Manual actuators	(a) Physically check that all actuators are secure, clean, undamaged and accessible.			
		(b) Test operation.			
		(c) Check contents of actuator cartridges (if fitted).gkPa			
2.8	System control and indicating equipment where fitted (see Clause 9.6)	(a) Test all indicators and audible alarms.			
		(b) Physically check that all panels are secure.			
		(c) Test battery capacity (if fitted) (see Note 1).			
2.9	Nozzles	Remove all nozzle caps, clean nozzles and refit caps (see Note 2)			

NOTES:

- 1 Where a system discharge test is conducted, the battery test shall be conducted following the discharge test.
- 2 In certain environments more frequent cleaning may be required.

TABLE 11.4
YEARLY ROUTINE SERVICE SCHEDULE

Item No.	Item	Action required and pass/fail requirement	Results	Pass/fail	Comments
3.1	Six monthly service	Complete all six-monthly routine service activities listed in Table 11.3			
3.2	Storage containers	(a) Remove container and inspect mounting bracket and container for damage and condition. (b) Check date of test or manufacture on storage container.date		
3.3	Aerosol generators	Replace any generator that will exceed its listed service life prior to the next scheduled routine service.			
3.4	Distribution system	Conduct clear-passage test using dry nitrogen and physically check distribution system, (i.e. that hoses, tube, fittings and supports are secure).			
3.5	Actuation system	(a) Pneumatic actuation system (if fitted)— (i) test pneumatic circuits for leaks (ii) check hoses, tube, fittings and supports are secure (b) Electric actuation system (if fitted)— (i) function test all actuation circuits (ii) check all wiring for earths (iii) check wiring, connections and supports are secure			
3.6	Detection system	(a) Pneumatic detection system (if fitted)— (i) test pneumatic circuits for leaks (ii) check hoses, tube, fittings and supports are secure (b) Electric detection system (if fitted)— (i) function test all detectors (ii) check all wiring for earths (iii) check wiring, connections and supports are secure			
3.7	Discharge test (optional)	(a) Conduct discharge test and record result (see Clause 10.2). (b) Check fire suppression system nozzle area coverage. s		
3.8	System interface and shutdown	Test all fire suppression system activated equipment shutdowns and record delay time. s		
3.9	Detector sensing element with a listed lifetime	Replace any detector sensing element that will exceed its listed lifetime prior to the next scheduled maintenance.			

(continued)

TABLE 11.4 (continued)

Item No.	Item	Action required and pass/fail requirement	Results	Pass/fail	Comments
3.10	Pyrotechnic actuators	Replace any actuator that will exceed its listed lifetime prior to the next scheduled maintenance.			
3.11	Mechanical actuator	Service and lubricate all mechanical actuators in accordance with the manufacturer's recommendations.			
3.12	Strainers, filters and check valves (where fitted)	Check and clean line strainers, filters and check for correct orientation of check valves.			
3.13	Pre-mix extinguishing agent solution	(a) Check solution condition in each container in accordance with manufacturer's procedure. (b) Replace as required or at the frequency specified by the manufacturer (see Note).			
3.14	Nozzle obstructions	Check for adequate clear space at nozzles and for obstructions likely to impede discharge.			
3.15	Nozzle orientation	Check nozzles are pointing at the pre-determined aiming points.			
3.16	Nozzle location and coverage	Check for the introduction of fixtures and bulkheads shielding nozzle discharge and the presence of unprotected hazard areas, particularly where a source of fuel and heat exists.			
3.17	Detector coverage	Check for the presence of unprotected hazard areas, particularly where a source of fuel and heat exists.			
3.18	Operational conditions	Check that the detector response and extinguishing agent discharge or retention will not be adversely affected by such things as enclosure openings, ventilation airflows or high temperature protected areas.			
3.19	Environmental conditions	Check that the fire system and its components are suitable for the environmental conditions in which the machine is operating, e.g. that components are suitable for underground mining, and road gradient and slopes are within container orientation limits.			
3.20	Survey	Complete review of system to confirm it is in accordance with the approved design and no changes have been made which would impair performance.			

NOTE: More frequent replacement of premix solution may be required (see Clause 11.5).

TABLE 11.5
FIVE YEARLY ROUTINE SERVICE SCHEDULE

Item No.	Item	Action required and pass/fail requirement	Results	Pass/fail	Comments
4.1	Yearly service	Complete all yearly routine service activities detailed in Table 11.4			
4.2	Container	Subject the container to a hydrostatic pressure test in accordance with AS 2030.1 (see Note)			
4.3	Container valves	Service and lubricate in accordance with the manufacturer's recommendations			
4.4	Extinguishing agent	(a) Concentrate—analyse. (b) Wet chemical—analyse. (c) Water or Powder—examine.			

NOTE: Cylinders that have been subjected to aggressive conditions may require hydrostatic pressure testing at greater frequencies.

APPENDIX A REFERENCED DOCUMENTS

(Normative)

AS	
1180	Methods of test for hose made from elastomeric materials
1180.10B	Determination of combustion propagation characteristics of a horizontally oriented specimen of hose using surface ignition
1210	Pressure vessels
1318	SAA Industrial Safety Colour Code
1319	Safety signs for the occupational environment
1674	Safety in welding and allied processes
1674.1	Part 1: Fire precautions
1674.2	Part 2: Electrical
1851	Routine service of fire protection systems and equipment
1890	Thermally released links
2030	Gas cylinders
2030.1	Part 1: General requirements
2067	Substations and high voltage installations exceeding 1 kV a.c.
2444	Portable fire extinguishers and fire blankets—Selection and location
2469	Steel cylinders for compressed gases—Welded two-piece construction—0.1 kg to 150 kg
2470	Steel cylinders for compressed gases—Welded three-piece construction with longitudinal joint—11 kg to 150 kg
2473	Valves for compressed gas cylinders
2473.1	Part 1: Specifications, type testing, and manufacturing tests and inspections
2613	Safety devices for gas cylinders
2700	Colour standards for general purposes
2706	Numerical values—Rounding and interpretation of limiting values
3791	Hydraulic hose
4024	Safety of machinery
4024.1603	Part 1603: Design of controls, interlocks and guards—Prevention of unexpected start-up
4343	Pressure equipment—Hazard levels
4487	Condensed aerosol fire extinguishing systems—Requirements for system design, installation and commissioning and test methods for components
4587	Water mist fire protection systems—System design, installation and commissioning
60068	Environmental testing
60068.2.2	Part 2.2: Tests—Test B: Dry heat
60068.2.6	Part 2.6: Tests—Test Fc: Vibration (sinusoidal)
60529	Degrees of protection provided by enclosures (IP code)

AS/NZS	
1841	Portable fire extinguishers
1841.1	Part 1: General requirements
1850	Portable fire extinguishers—Classification, rating and performance testing
3000	Wiring Rules
3100	Approval and test specification—General requirements for electrical equipment
3509	LP Gas fuel vessels for automotive use
4801	Occupational health and safety management systems—Specification with guidance for use
61000 Electromagnetic compatibility (EMC)	
61000.6.2	Part 6.2: General standards—Immunity for industrial environments
61000.6.4	Part 6.4: Generic standards—Emission standard for industrial environments
AS ISO	
14520	Gaseous fire-extinguishing systems—Physical properties and system design
SA/SNZ	
HB 436	Risk management guidelines—Companion to AS/NZS ISO 31000:2009
ISO	
6682	Earth-moving machinery—Zones of comfort and reach for controls
6801	Rubber or plastics hoses—Determination of volumetric expansion
8030	Rubber and plastics hoses—Method of test for flammability
13766	Earth-moving machinery—Electromagnetic compatibility
NFPA	
11	Standard for Low-, Medium-, and High-Expansion Foam
17	Standard for Dry Chemical Extinguishing Systems
17A	Standard for Wet Chemical Extinguishing Systems
750	Standard on Water Mist Fire Protection Systems
UL	
1254	Pre-Engineered Dry Chemical Extinguishing System Units
MSHA	
2G	USA Bureau of Mines, Schedule 2G, March 19, 1968

APPENDIX B

TYPES OF RISK ANALYSIS

(Informative)

B1 GENERAL

The objective of risk analysis is to provide an input to decisions on whether risks need to be treated and the most appropriate and cost-effective risk treatment strategies. Risk analysis involves consideration of the sources of risk, their positive and negative consequences and the probabilities that those consequences may occur. Factors that affect consequences and probability may be identified. Risk is analysed by combining consequences and probabilities, taking into account existing control measures.

A preliminary analysis can be carried out so that similar risks are combined or low-impact risks are excluded from detailed study. Excluded risks are, where possible, listed to demonstrate the completeness of the risk analysis.

Risk analysis may be undertaken to various degrees of detail depending upon the risk, and the information, data and resources available. Analysis may be qualitative, semi-quantitative or quantitative or a combination of these, depending on the circumstances. The order of complexity and costs of these analyses, in ascending order, is qualitative, semi-quantitative and quantitative. In practice, simple qualitative analysis is often used first to obtain a general indication of the level of risk and to reveal the major risk issues. Later it may be necessary to undertake more specific or quantitative analysis on the major risk issues. The form of analysis should be consistent with the risk evaluation criteria developed as part of establishing the context.

The way in which probabilities and consequences are expressed and the ways in which they are combined to provide a level of risk will vary according to the type of risk and the purpose for which the risk assessment output is to be used. The effect of uncertainty and variability of each factor on the level of risk should be considered and communicated effectively.

B2 QUALITATIVE ANALYSIS

Qualitative analysis uses word forms or descriptive scales to describe the magnitude of potential consequences and the probability that those consequences will occur. These scales can be adapted or adjusted to suit the circumstances, and different descriptions may be used for different risks.

Qualitative analysis may be used—

- (a) as an initial screening activity to identify risks which require more detailed analysis;
- (b) where this kind of analysis is appropriate for decisions; or
- (c) where the numerical data or resources are inadequate for a quantitative analysis.

B3 SEMI-QUANTITATIVE ANALYSIS

In semi-quantitative analysis, qualitative nominal scales such as those described above are given values. The objective is to produce a more detailed prioritization than is usually achieved in qualitative analysis, not to suggest any realistic values for risk such as is attempted in quantitative analysis. However, since the number allocated to each description may not bear an accurate relationship to the actual magnitude of consequences or probabilities, the numbers can only be combined using an appropriate formula that recognizes the limitations of the kinds of scales used. Care should be taken with the use of semi-quantitative analysis because the numbers chosen may not properly reflect relativities and this can lead to inconsistent, anomalous or inappropriate outcomes. Semi-quantitative analysis may not differentiate properly between risks, particularly when either consequences or probabilities are extreme.

B4 QUANTITATIVE ANALYSIS

Quantitative analysis uses numerical values (rather than the descriptive scales used in qualitative and semi-quantitative analysis) for both consequences and probabilities using data from a variety of sources. The quality of the analysis depends on the accuracy and completeness of the numerical values and the validity of the models used.

Consequences may be estimated by modelling the outcomes of an event or set of events, or by extrapolation from experimental studies or past data. Consequences may be expressed in terms of monetary, technical or human impact criteria, environmental or other criteria such as operational or legal. In some cases, more than one numerical value is required to specify consequences for different times, places, groups or situations.

B5 SENSITIVITY ANALYSIS

Since some of the estimates made in risk analysis are imprecise, a sensitivity analysis should be carried out to test the effect of uncertainty in assumptions and data. Sensitivity analysis may also be a way of testing the appropriateness and effectiveness of potential controls and risk treatment options.

APPENDIX C
HOSE AND WIRING RETICULATION DIAGRAMS
(Informative)

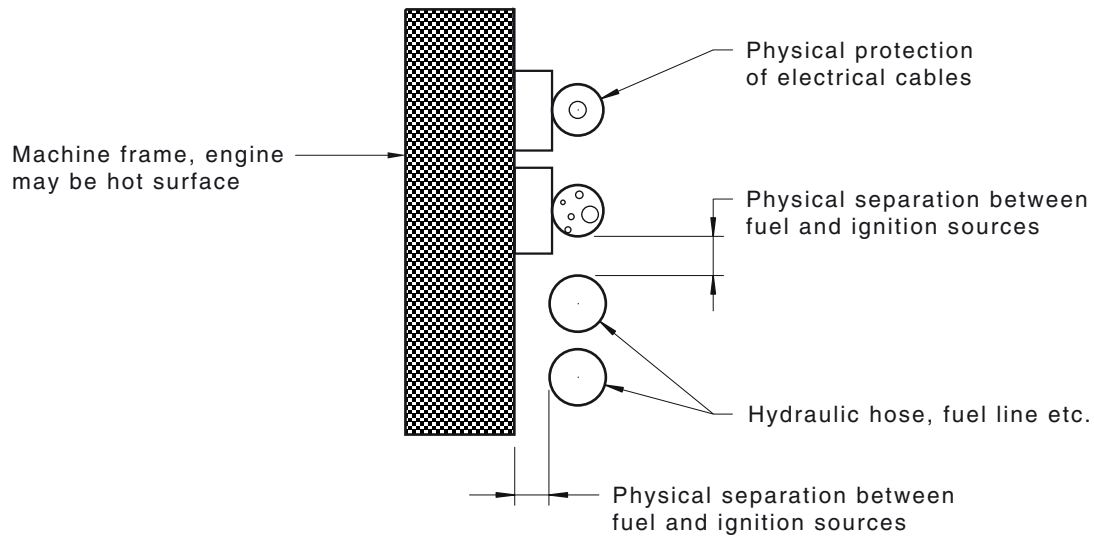

FIGURE C1 EXAMPLE OF GOOD PRACTICE—GOOD SEPARATION BETWEEN FUEL AND IGNITION SOURCES; PHYSICAL PROTECTION OF CABLES

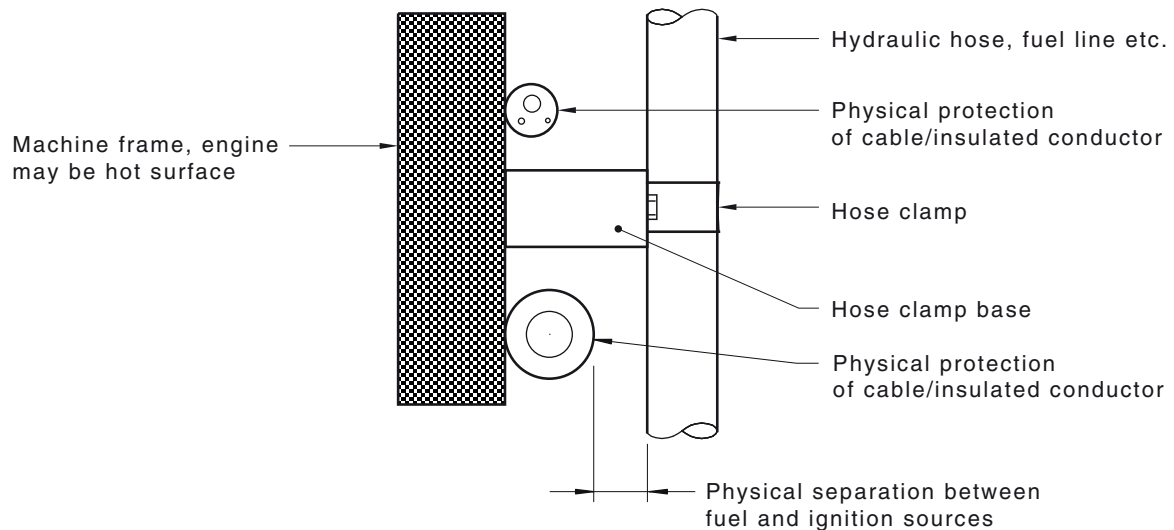
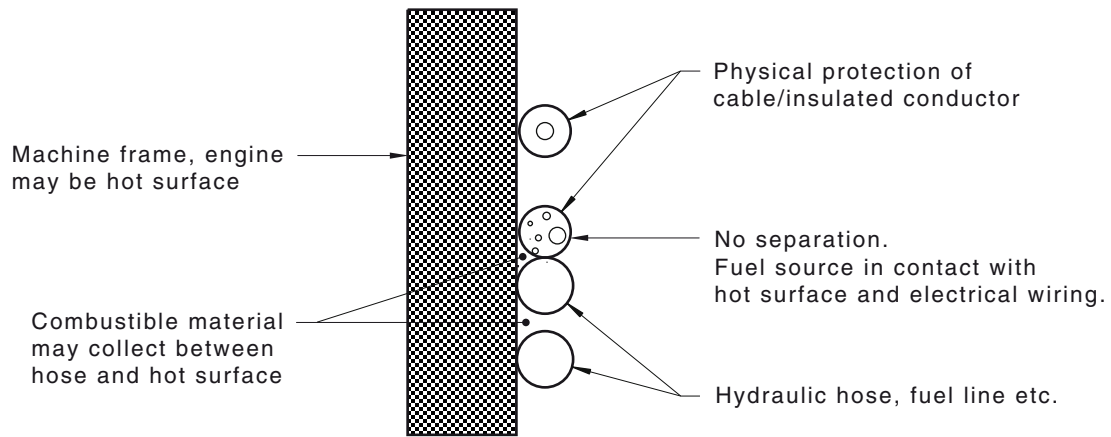

FIGURE C2 EXAMPLE OF GOOD PRACTICE—GOOD SEPARATION BETWEEN FUEL AND IGNITION SOURCES; PHYSICAL PROTECTION OF ELECTRICAL CABLES; HOSES SECURE



NOTE: With electrical wiring and hoses located in this position, combustible material may collect around the wiring and hoses. Where there is intimate contact with hot surfaces, hoses, electrical wiring and its protection should have appropriate thermal rating.

FIGURE C3 EXAMPLE OF POOR PRACTICE—INADEQUATE HOSE AND WIRE SEGREGATION

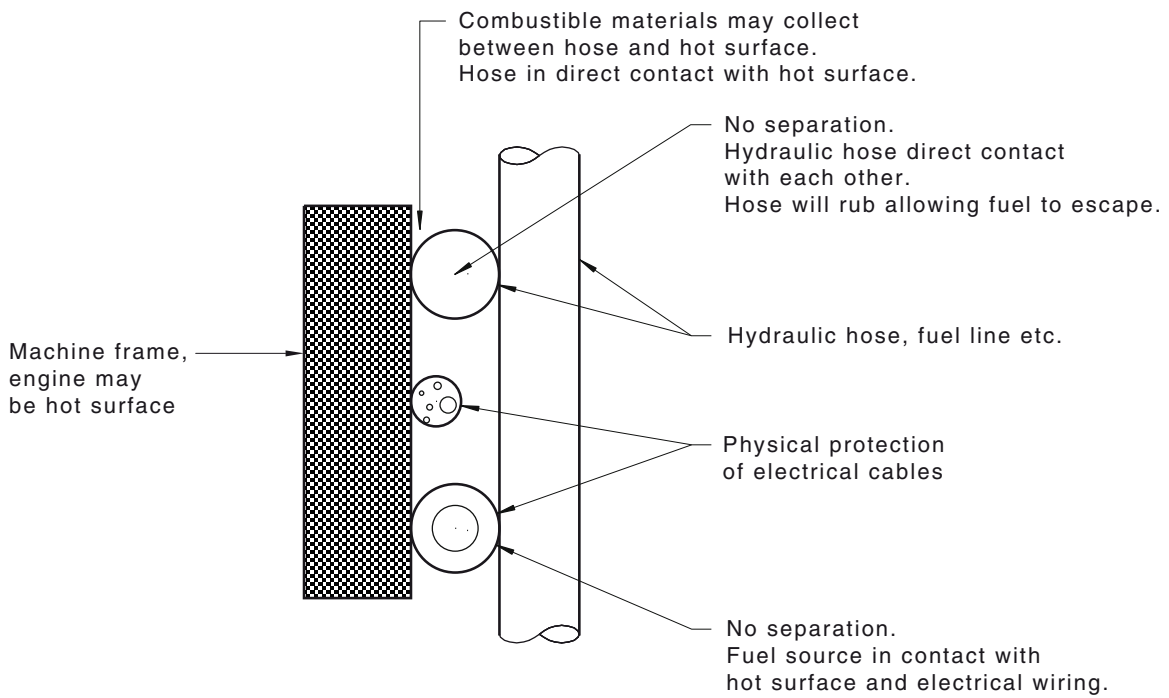

FIGURE C4 EXAMPLE OF POOR PRACTICE—NO SEGREGATION OF FUEL AND IGNITION SOURCES

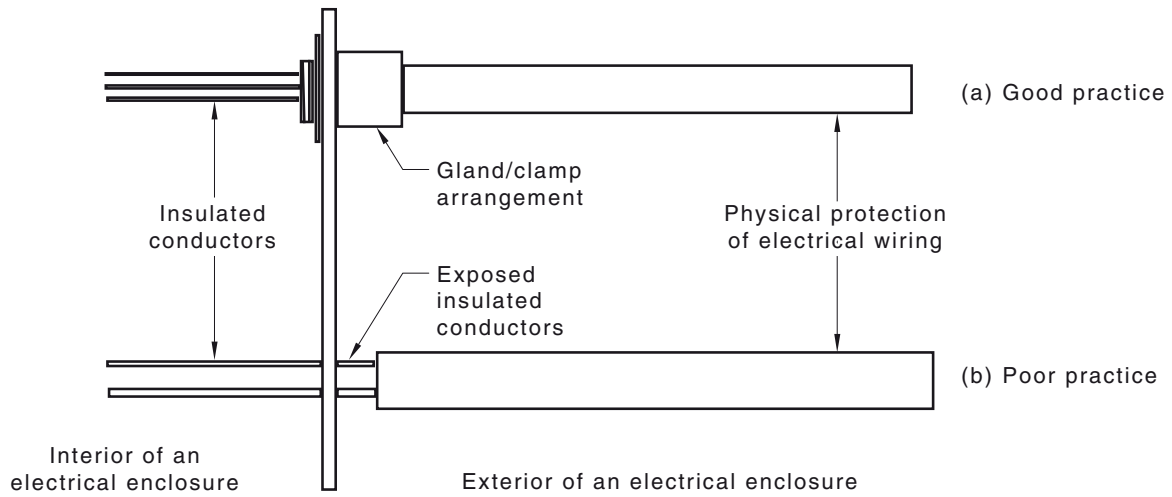

FIGURE C5 EXAMPLES OF GOOD AND POOR WIRING THROUGH WALLS

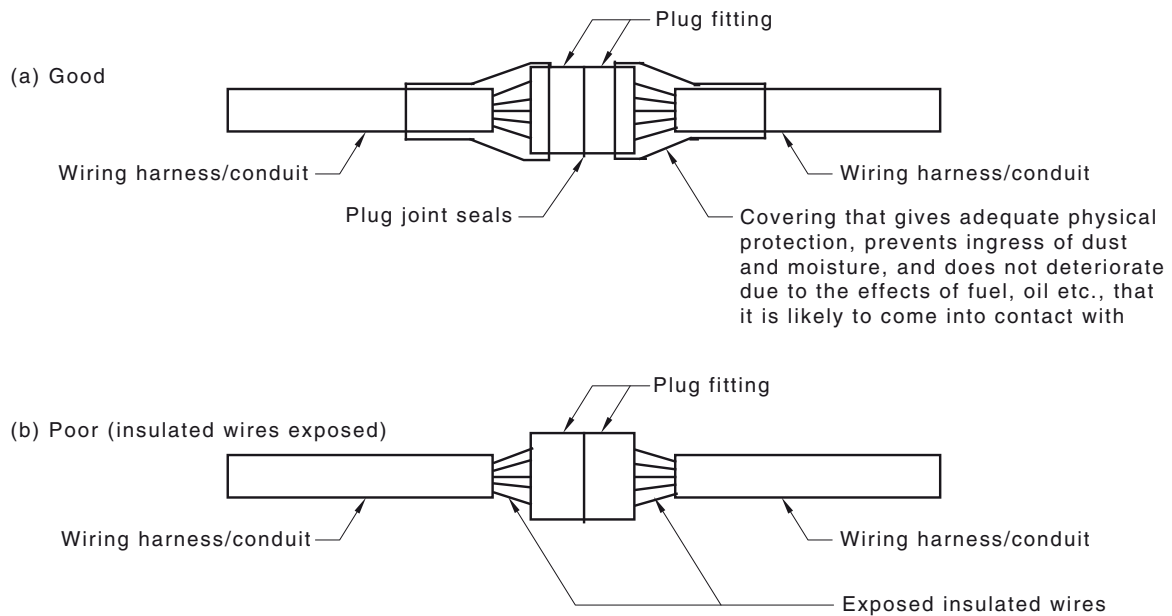

FIGURE C6 EXAMPLE OF GOOD AND POOR CONNECTORS

APPENDIX D
ASSESSMENT OF COMPONENT COMPLIANCE FOR FIRE
PROTECTION SYSTEMS

(Normative)

To meet the requirements for listing, the criteria for acceptance given in Table D1 shall be achieved.

TABLE D1
ENDURANCE AND PERFORMANCE TESTS FOR FIRE PROTECTION SYSTEM COMPONENTS

Test No.	Component to be tested	Test procedure	Name of test	Basic test procedures and criteria for acceptance
1	Fully charged extinguishing system units (applicable only to systems using agent storage containers coupled to discharge pipework and nozzles)	Based on UL 1254	Flow distribution	<p>For each container size, the container is to be filled to its rated capacity with extinguishing agent and pressurized. The discharge piping and nozzle configuration shall be the maximum allowable in accordance with the manufacturer's listed manual. Containers such as plastic bags and buckets are to be used to collect the amount of agent discharged from each nozzle. The extinguishing system unit is to be actuated and the discharge time to gas point measured to determine discharge rate. After discharge completion the amount of extinguishing agent from each nozzle is to be weighed to determine nozzle discharge quantities.</p> <p>The measured discharge rate and quantity of agent from the hydraulically least favourable nozzle shall be the rate and quantity used for the fire test.</p>
2	Containers	AS 2030.1	Hydrostatic pressure test	Hydrostatic pressure testing of containers shall be in accordance with AS 2030.1.
3	Fully charged extinguishing system unit	Based on UL 1254	30-day elevated temperature test	<p>A typical extinguishing system unit conditioned at its maximum operating temperature for a period of 30 days shall discharge not less than 85% (by weight) of the rated extinguishing agent charge.</p> <p>There shall be no visible signs of leakage of the extinguishing system unit including pressurized actuation devices during and at the end of the conditioning period.</p>
4	Fully charged extinguishing system units	Based on UL 1254	Temperature cycling test	<p>A fully charged fire protection system unit is to be maintained at the minimum storage temperature for 24 h, then at the maximum storage temperature for 24 h and then again at the minimum storage temperature for 24 h. The unit is then to be conditioned to 21°C for 24 h, after which it is to be checked for leakage.</p> <p>The fully charged fire protection system unit, including pressurized actuation devices shall not show any visible signs of leakage.</p>
5	Nozzles and nozzle caps fitted with elastomer seals	Based on AS 60068.2.2	Ageing test	<p>Six nozzles complete with caps are to be conditioned to a temperature of 125°C for 240 h. On completion of the aging test, each of the nozzle caps shall be inspected to ensure they have remained in place on the nozzle without loss of sealing integrity.</p> <p>On the completion of this test, subject the nozzles and nozzle caps to Test 13.</p>

(continued)

TABLE D1 (continued)

Test No.	Component to be tested	Test procedure	Name of test	Basic test procedures and criteria for acceptance
6	Fully charged extinguishing system units including attachments required for installation	Based on UL 1254	Salt spray corrosion test	<p>The test samples are to be supported vertically and exposed to salt spray in a test chamber. The test chamber shall be supplied with salt solution and warm humidified air to disperse the salt solution into a fine mist throughout the interior of the chamber. The temperature of the chamber is to be maintained between 33°C and 36°C. Condensation accumulation on the cover of the chamber is not to be permitted to drop onto the test samples and drops of the solution that fall from the samples are not to be recirculated.</p> <p>The salt solution is to consist of 5% (by weight) of common salt (sodium chloride) and distilled water. The pH value of the solution as collected after being sprayed in the test apparatus shall be between 6.5 and 7.2 at 35°C.</p> <p>The test duration shall be 240 h.</p> <p>The fire protection system unit shall withstand exposure without incurring damage that would impair function. Superficial discolouration with no substantial attack of underlying material shall be acceptable.</p> <p>When any part of the system has a corrosion resistant coating, the coating shall be intact and not be removable by rinsing with tap water or rubbing with a finger.</p> <p>Where the system has a pressure gauge, the gauge shall have no moisture inside.</p>
7	Discharge valves, including actuation devices NOTE: Not applicable to fire protection system units of the fusible element type.	Based on UL 1254	500 cycle operation test	<p>Each type of actuator and container valve available for use in the system shall operate as intended for 500 operations without malfunction or damage.</p> <p>Each extinguishing system unit to be tested shall be connected to a nitrogen source and fitted with a pressure regulating device or other equivalent means and pressurized to the operating pressure at 21°C. The valve shall be cycled from fully closed to fully open 500 times.</p> <p>Sealing portions of components shall be cleaned prior to completing the following test. After cycling specified above, the discharge valve and actuation devices shall be subjected to an air or nitrogen under water leakage test at the operating pressure at 21°C. There shall be no signs of leakage as evidenced by air or nitrogen bubbles. The inlet of the component under test is to be fitted with a pressure regulating device or equivalent means and pressurized to its operating temperature at 21°C. The component shall then be immersed in water and examined for leakage for one minute.</p>

(continued)

TABLE D1 (continued)

Test No.	Component to be tested	Test procedure	Name of test	Basic test procedures and criteria for acceptance
8	Mounting brackets for fire protection system container/valve assemblies	Based on UL 1254	Mounting device test	The mounting bracket for an extinguishing system container/valve assembly that is not intended to be directly supported by the floor shall withstand for 5 min a static load, applied vertically downward, of five times the fully charged weight of the extinguishing system unit, and not less than 45 kg.
9	Manual actuators and pull stations	Based on UL 1254	Operation test of manual actuators and manual pull stations	<p>A manual actuator or manual pull station shall not require a pull or push of more than 180 N nor a movement greater than 360 mm to release the extinguishing agent.</p> <p>Cable pull manual pull stations shall be fitted with the maximum length of cable and maximum number of corner pulleys.</p> <p>Manual actuators that operate against the internal pressure of a system unit shall be tested with the system pressurized to simulate maximum operating pressure.</p>
10	Valves and other components intended to be pneumatically operated by a master valve or by other pneumatic means	Based on UL 1254	Pneumatic operation test	<p>A primary means of actuation that is intended to discharge multiple container/valve assemblies shall result in the operation of all the connected container/valve assemblies to occur within a 1 s maximum time interval between operation of the first container/valve assembly and the last container/valve assembly.</p> <p>A master valve and container or remote actuator shall be filled and pressurized to their operating pressure at 21°C and then conditioned at their minimum operating temperature for at least 16 h. The maximum number of valves or other devices, and the maximum amount and size of tubing or piping intended to be operated by the master valve or remote actuator are then to be installed and pressurized (where applicable) to the operating pressure that corresponds to the pressure at the maximum operating temperature. The system is then to be discharged.</p>
11	Burst discs	AS 2613	Pressure relief test	The requirements for burst discs shall be in accordance with AS 2613.

(continued)

TABLE D1 (continued)

Test No.	Component to be tested	Test procedure	Name of test	Basic test procedures and criteria for acceptance
12	Fire protection system units	Based on AS 60068.2.6, Table C2	Vibration test	<p>A representative sample of the charged extinguishing system using the heaviest container shall be mounted in its own bracket (when provided), or in a standard mounting fixture and connected to a distribution ring main containing six (6) nozzles complete with nozzle caps, fitted in accordance with the manufacturer's instructions. The fire protection system unit shall include all components used in a typical system and be secured to the vibration test apparatus in the manner in which the unit is intended to be installed.</p> <p>Test through a frequency range of 10 Hz to 150 Hz, acceleration 5 g, 1 octave per minute, 20 cycles per axis (3 orthogonal axes).</p> <p>The fire protection system unit and its mounting brackets including all actuation and discharge components intended for use on the equipment shall withstand the vibration and shock resistance test (Test 14) without—</p> <ul style="list-style-type: none"> (a) becoming inoperable; (b) nozzle caps becoming dislodged (c) causing a risk of injury to persons; (d) dislodgement of the siphon tube; and (e) experiencing physical deterioration or breakage of components to the extent that requires repair or replacement of the extinguishing system unit or components, or both, or of the bracket before they are returned to service. <p>For example, broken welds, malfunctions of operating parts, or abrading or scoring of the container in excess of 10% of the minimum wall thickness do not comply with this requirement.</p> <p>The fire extinguishing systems shall then be actuated via each pneumatic and mechanical actuation option. Electric actuation shall be via the fire panel. Each system shall discharge not less than 85% of the contents through the reticulation system and out of all nozzles.</p>
13	Nozzles and nozzle caps	—	Blow off test	<p>Select the hydraulically worst-case system configuration determined in Test 1. Charge the container to 90% of its rated minimum pressure at 21°C.</p> <p>On the operation of the system, all the nozzle caps shall release.</p>

(continued)

TABLE D1 (continued)

Test No.	Component to be tested	Test procedure	Name of test	Basic test procedures and criteria for acceptance
14	Fully charged extinguishing system units including attachments required for installation	Based on UL 1254	Shock test	An extinguishing system unit and its mounting bracket shall withstand 3 successive shocks applied in each direction of three mutually perpendicular axes of the specimen, that is a total of 18 shocks at an acceleration of 15 g and duration of 11 ms without leakage or cracking, displacement, breakage, or damage of components to the extent that the unit does not operate as intended.
15	Plastic valve parts or brackets	Based on UL 1254	Air oven aging test	(a) Following air-oven aging for 180 days at 100°C, there shall be no cracking of a plastic valve, valve part, part subjected to the flow of extinguishing agent, or bracket. (b) Following air-oven aging for 180 days at 100°C, aged samples of the valve, valve part, bracket, or container shall perform as intended when tested as specified in the following UL 1254 tests: (i) Test 2 (valves and parts); Hydrostatic pressure test. (ii) Test 11 (containers); (brackets). (iii) Test 23 Burst Strength—Pressure indicators, (pressurized gauge components). (c) Following air-oven aging for 90 days at 100°C, there shall be no cracking of a plastic siphon tube, and aged samples of the siphon tube shall perform as intended. (d) Following air-oven aging for 90 days at 100°C, ring samples cut from the aged tube shall not exhibit a degradation in excess of 40% of the original tensile or ring crushing strength values. (e) When plastic parts are attached to other parts or assemblies, the securement of the parts shall not be impaired after air-oven aging.
16	Plastic siphon tubes	Based on UL 1254	Exposure to extinguishing agent test	Plastic siphon tubes shall be immersed in extinguishing agent for 210 days at the maximum operating temperature (see Test 3—30-day elevated temperature test) (a) Plastic siphon tubes shall perform as intended. (b) Ring samples shall not exhibit degradation in excess of 40% of the original tensile or ring crushing strength values.

(continued)

TABLE D1 (continued)

Test No.	Component to be tested	Test procedure	Name of test	Basic test procedures and criteria for acceptance
17	Plastic valve parts	Based on UL 1254	Light and water test	<p>(a) There shall be no cracking of materials used for a plastic valve, exposed valve part, or bracket after exposure to light and water for 720 h.</p> <p>(b) Samples of the valve or valve part or bracket so exposed shall perform as intended when tested as specified in UL 1254 tests:</p> <p>(i) Test 32 (valves and parts); Hydrostatic pressure test.</p> <p>(ii) Test 38 Mounting device (containers); 38.1 (brackets).</p> <p>(iii) Test 48 Burst Strength—Pressure Indicators, (pressurized gauge components).</p> <p>Hydrostatic pressure test, Section 32 (containers); 32.2.1 (valves and parts); Mounting Device Test, Section 38 (brackets); or the Burst strength tests—Gauges and indicators, Section 48 (gauges). See 45.1.4.</p> <p>(c) When a gauge or indicator is involved in this test, it shall remain watertight throughout the test.</p>
18	Pressure indicators	Based on AS/NZS 1841.1	Calibration test	<p>The minimum range of the pressure indicator shall extend from 0.5 to 1.5 times working pressure of the container. The accuracy of the indicator shall be $\pm 10\%$ of the nominal working pressure at $23 \pm 2^\circ\text{C}$ at the designated nominal pressure.</p> <p>The pressure indicator shall indicate the operable pressure range of the extinguisher in contrasting colour to the remainder of the indicator. The working pressure shall be shown in numerals.</p>
19	Pressure indicators	—	Burst strength test	A pressure indicator shall withstand, for 1 min without rupture, a pressure equal to the nominal burst disc pressure of the container to which it is fitted.
20	Nameplates	—	Nameplate exposure test	Nameplates shall be fitted to the extinguishing system units for all preceding temperature, salt spray, vibration and shock tests. Following each test the nameplate shall remain attached and be legible.

(continued)

TABLE D1 (continued)

Test No.	Component to be tested	Test procedure	Name of test	Basic test procedures and criteria for acceptance
21	Liquid extinguishing agents	—	Agent Stability	<p>All liquid extinguishing agents shall remain homogeneous solutions when stored at the maximum and minimum specified temperatures. If a pre-mix extinguishing solution is used in the system then this test shall be completed on the solution. If the system uses an undiluted concentrate then this test shall be completed on the concentrate.</p> <p>Two 0.5 L samples of concentrate or solution, as appropriate, shall be placed in transparent closed containers. One shall be stored at the manufacturer's minimum specified temperature (but not greater than 1°C) and the other at the manufacturer's maximum specified temperature (but not less than 49°C). Both samples shall remain undisturbed for 90 days. At 30, 60 and 90 days the samples shall be examined for separation or stratification. No such separation or stratification shall be visible. Visible evidence of separation or stratification shall include the development of two or more distinct layers or the precipitation of any solids. Cloudiness or other changes in appearance without loss of homogeneity shall be acceptable.</p>

APPENDIX E

FIRE TEST METHOD FOR FOAM WATER SPRAY FIRE SUPPRESSION SYSTEMS

(Normative)

E1 SCOPE

This Appendix sets out the fire test method to evaluate the performance of foam water spray fire suppression systems referred to in this Standard. Two test procedures are detailed, as follows:

- (a) Fuel spill extinguishment and reignition test—Direct application.
- (b) Fuel spill extinguishment and reignition test—Indirect application.

E2 GENERAL REQUIREMENTS

The general principles for both tests in this Appendix shall be as follows:

- (a) The system to be tested shall consist of the container and discharge network combination (maximum number of nozzles, maximum flow demand, maximum permitted hose lengths and volumes) which results in the most hydraulically disadvantaged nozzle permitted in accordance with the manufacturer's design guidelines. The container shall be charged to the maximum allowable fill (minimum ullage).
- (b) Charge the container to the manufacturer's specified minimum operating pressure.
NOTE: This is that pressure at which the container supervisory pressure switch operates and indicates a fault.
- (c) The set-up shall utilize the maximum allowable pipe/hose lengths in the distribution network that are of the minimum diameter permitted in the manufacturer's guidelines.
- (d) The firefighting performance of the most hydraulically disadvantaged nozzle shall be evaluated using the test method described below.
NOTE: For systems that include more than one type of nozzle (flow rate and discharge pattern), each type of nozzle shall be tested.
- (e) All discharge nozzles shall be fitted with the manufacturer's specified discharge caps.
- (f) Nozzles in the system set-up that are not subjected to the fire test shall be configured to approximate a typical installation and the quantity of extinguishing agent discharged from each nozzle is to be measured and recorded.
- (g) The quantity of extinguishing agent delivered from each nozzle shall not vary by more than 10% of the expected quantity.
- (h) The main fire trays used in the tests shall be square and sized such that the length of the sides of the tray are not less than the diameter of the spray pattern of the nozzle being tested when mounted at its maximum permitted range. Construction of fire trays shall be in accordance with AS/NZS 1850 for Class B fire test.
- (i) The fire test shall be conducted under conditions where wind speed does not exceed 4.0 m/s.

The fire tests detailed in Paragraphs E3 and E4 shall be undertaken using containers filled and charged a minimum of 30 days prior to testing.

E3 TEST 1—FUEL SPILL EXTINGUISHMENT AND REIGNITION TEST—DIRECT APPLICATION

E3.1 General

The purpose of this test is to demonstrate that the fire suppression system is able to successfully extinguish a tray fire using direct application of the extinguishing agent.

E3.2 Principle

A diesel spray fire is maintained above the tray to demonstrate the extinguishing agent can adequately prevent reignition of the tray fire after discharge of the fire suppression system has been completed.

E3.3 Apparatus

The following apparatus is required:

- (a) Square main fire tray, representing the fuel spill, filled with diesel to a depth of 50 mm over 50 mm depth of water.
- (b) 25 L (nominal) capacity storage vessel charged with 12 L of diesel, pressurized to 1500 kPa. The outlet of the storage vessel shall be fitted with a ball valve to supply and control the flow of fuel to the diesel spray fire nozzle (single orifice nozzle with 1 mm orifice).

NOTE: This arrangement is representative of an unextinguished spray fire.

- (c) Pilot fire tray, used to ensure the continuous ignition of the diesel spray fire, 200 mm × 400 mm × 100 mm depth with 25 mm of diesel over 25 mm depth of water.

E3.4 Apparatus arrangement

The test apparatus shall be arranged as follows (see Figure E1):

- (a) The fire suppression system discharge nozzle complete with nozzle cap to be tested shall be positioned at its maximum permitted range **R** (as detailed in the manufacturer's design manual) directly above the centre of the main fire tray and aimed directly down at the centre of the tray.
- (b) The diesel spray fire nozzle shall be mounted at 1200 mm from the side of the main fire tray and aimed to direct the diesel spray fire across the top of the tray. The diesel spray nozzle shall be mounted such that the spray is directed 200 mm above the surface of the main fire tray.
- (c) The pilot fire tray shall be positioned underneath the diesel spray at a distance of 500 mm from the diesel spray fire nozzle.

E3.5 Procedure

The procedure shall be as follows:

- (a) Ignite the main and pilot fire trays.
- (b) After 1 min and 45 s, pre-burn initiate the diesel spray.
- (c) After 2 min, manually operate the fire suppression system and allow the system to completely discharge.
- (d) 30 s after completion of effective discharge of the fire suppression system, shut off the diesel spray.

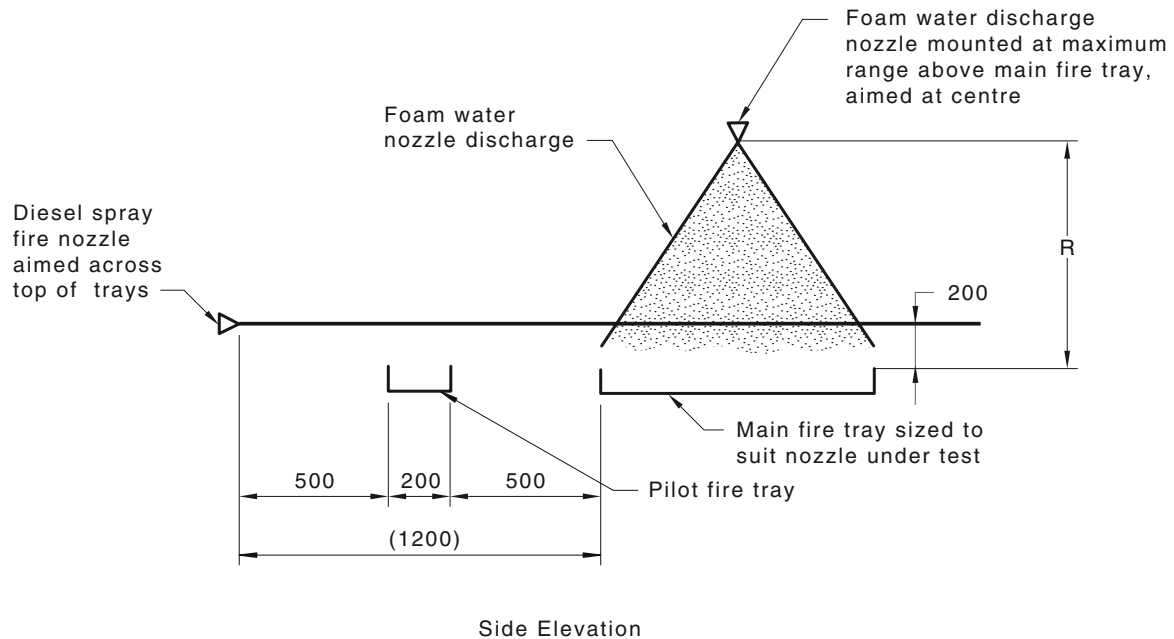

DIMENSIONS IN MILLIMETRES

FIGURE E1 TEST 1—FUEL SPILL EXTINGUISHMENT AND REIGNITION TEST—
DIRECT APPLICATION

E3.6 Records

The following information shall be recorded:

- (a) Date and time of test.
- (b) Ambient temperature.
- (c) Time required to achieve extinguishment of main fire tray.
- (d) Any reignition of fire tray.
NOTE: Reignition of the fire tray constitutes a failed test.
- (e) Effective discharge time of the system.
- (f) Size of container.
- (g) Size and length of discharge pipework/hose.
- (h) Number and details of nozzles fitted to discharge network.
- (i) Quantity of agent in container.
- (j) Solution strength.
- (k) Type and quantity of any additives.
- (l) The performance of the nozzle and caps.
- (m) Discharge pressure at most hydraulically disadvantaged nozzle.
- (n) Pressure of diesel spray at nozzle.

E4 TEST 2—FUEL SPILL EXTINGUISHMENT AND FUEL SPRAY REIGNITION TEST—INDIRECT APPLICATION

E4.1 General

The purpose of this test is to demonstrate that the fire suppression system is able to successfully extinguish a baffled tray fire and prevent reignition of a spray fire using indirect application of the extinguishing agent.

E4.2 Principle

A diesel spray fire is maintained on a reignition plate to demonstrate the cooling capacity of the extinguishing agent is adequate to prevent reignition of the diesel after the discharge of the fire suppression system has been completed.

E4.3 Apparatus

The following apparatus is required:

- (a) Square main fire tray, representing the fuel spill, with diesel to a depth of 50 mm over 50 mm depth of water.
- (b) 25 L (nominal) capacity storage vessel with 12 L of diesel, pressurized to 1500 kPa. The outlet of the storage vessel shall be fitted with a ball valve to supply and control the flow of fuel to the diesel spray fire nozzle (single orifice nozzle with 1 mm orifice). This arrangement is to represent an unextinguished spray fire.
- (c) Square 3 mm thick steel reignition plate, of side dimensions not less than that of the main fire tray, simulating the engine's non-fire heated surfaces such as exhaust manifold etc.

E4.4 Apparatus arrangement

The test apparatus shall be arranged as follows (see Figure E2):

- (a) The 3 mm steel reignition plate shall be mounted vertically above the main fire tray such that the plate is located a third of the width of the fire tray from the front edge of the tray. The bottom edge of the plate shall be mounted 100 mm above the fire tray. The reignition plate shall be fixed in position and prevented from moving during the test.
- (b) The fire suppression system discharge nozzle to be tested shall be positioned at its maximum permitted range **R** (as detailed in the manufacturer's design manual) and aimed at the centre of the reignition plate.
- (c) The diesel spray fire nozzle shall be mounted at 1200 mm from the steel reignition plate in line with the edge of the fire tray. The diesel spray shall be aimed directly at the centre of the steel plate.

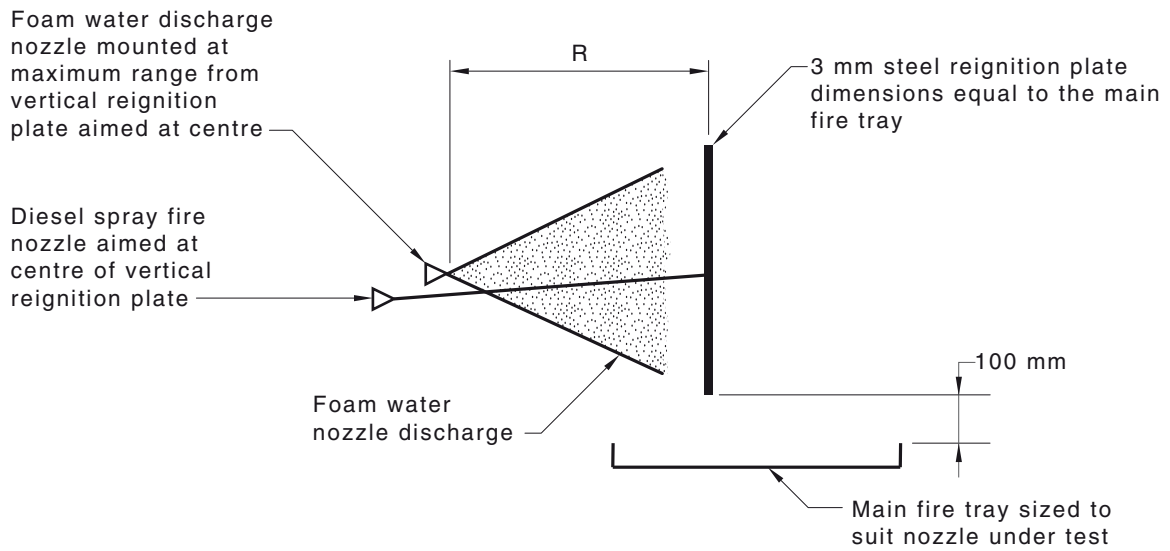

(a) Side elevation

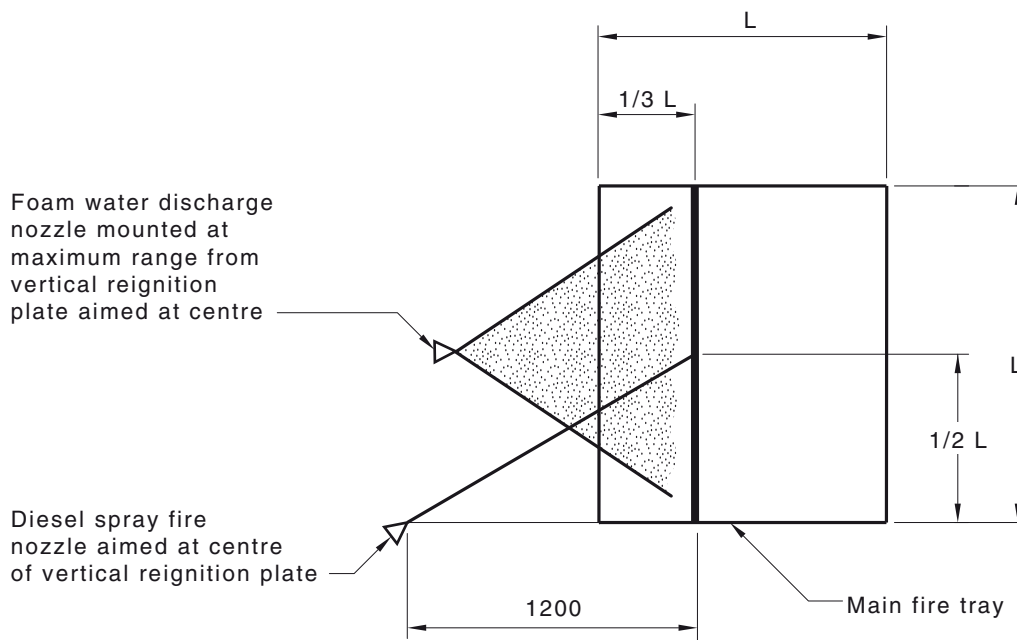

(b) Plan view

DIMENSIONS IN MILLIMETRES

FIGURE E2 FIRE TEST 2—FUEL SPILL EXTINGUISHMENT AND FUEL SPRAY REIGNITION TEST—INDIRECT APPLICATION

E4.5 Procedure

The procedure shall be as follows:

- (a) Ignite the main fire tray.
- (b) Immediately ignite the diesel spray fire.
- (c) Allow 2 min pre-burn.
- (d) Manually operate the fire suppression system and allow the system to completely discharge.
- (e) On completion of effective discharge of the fire suppression system, shut off the diesel spray.
- (f) Immediately restart the diesel spray for 15 s.

E4.6 Records

The following information shall be recorded:

- (a) Date and time of test.
- (b) Ambient temperature.
- (c) Time required to achieve extinguishment of main fire tray.
- (d) Any reignition of the diesel spray or fire tray.
NOTE: Reignition of the diesel spray constitutes a failed test.
- (e) Effective discharge time of the system.
- (f) Size of container.
- (g) Size and length of discharge pipework/hose.
- (h) Number and details of nozzles fitted to discharge network.
- (i) Quantity of agent in container.
- (j) Solution strength.
- (k) Type and quantity of any additives.
- (l) The performance of the nozzle and caps.
- (m) Pressure of diesel spray at nozzle.

E5 REPORTING

Test reports for each test shall include the following:

- (a) Name and address of the testing organization.
- (b) Number, publication date, and amendment version, of any referred Standards.
- (c) Date of tests.
- (d) Name of manufacturer or manufacturer's agent.
- (e) Trade name, model number and revision level of the system.
- (f) Rating/performance information.
- (g) Description and photograph(s) of tested system (item) and tested configuration.
- (h) Description of test procedures.
- (i) Results of tests.
- (j) A statement indicating whether or not the system tested complies with the requirements of this Standard.

APPENDIX F
PRE-ENGINEERED FIRE PROTECTION SYSTEM SAMPLE
COMMISSIONING REPORT

(Informative)

COMMISSIONING REPORT

Name and installer:

Address:

Commissioning date:.....

Type of fire protection system

This system has been installed in accordance with manufacturer’s design documentation and AS 5062:2016.

Name of client.....

Equipment being protected (make/model)

Equipment identification/serial number

Fire hazard locations being protected.....

Extinguishing agent container serial number

Discharge completed Y/N/NA (circle)Nozzle coverage acceptable Y/N/NA (circle)

Design discharge time.....

Actual discharge time.....

Equipment shutdown delay period.....

Licensed to PT Indonesian Fire Equipment Systems - Corporate Copy on 14-Nov-2018. 1 user personal license only. Copying, copy/pasting, storage & distribution or use on network prohibited. Get permission to copy from or network this publication www.saiglobal.com/licensing

COMMISSIONING CHECKLIST

Item	Task	Reference from listed manual or Clause number from AS 5062	Compliance (Mark: Yes, No, or Not applicable)
1.	System configuration		
2.	Signs and warning labels		
3.	Containers: (a) Location (b) Number (c) Size (d) Marking (e) Charge quantity (f) Fill weight (e) Orientation (f) Mounting		
4.	Release mechanisms: (a) Location (b) Connections (c) Pneumatic leak test of actuation pressure lines (where fitted) (d) Mechanical release		
5.	Manifolds and valves—Location and number: (a) Joints and fastenings (b) Flexible connections (c) Discharge indicators (d) Pressure switches (e) Check valves (f) Pressure relief devices (g) Vent valves (h) Charging valves		
6.	Distribution systems (a) (i) Layout (ii) Size and fitting orientation (iii) Joints, nozzles and supports (b) Leak test (c) Free passage test		
7.	Nozzles (a) Identification (b) Orientation		
8.	Electrical system		

(continued)

Item	Task	Reference from listed manual or Clause number from AS 5062	Compliance (Mark: Yes, No, or Not applicable)
9.	Function tests (a) Local alarm (b) Equipment shutdown		
10.	Actuation system test (a) Audible alarms (b) Audible and visual alarms time delay (c) Shutdown override (d) Discharge time delay		

Additional Remarks:

.....

.....

.....

Signature of installer:

Position:.....

Date:.....

Accreditation No.:

APPENDIX G
 SAMPLE CERTIFICATE OF COMPLETION
 (Informative)

CERTIFICATE OF COMPLETION

PART 1: TO BE COMPLETED BEFORE TESTING

We (name of installer)

of (address)

hereby certify that we have completed on (date)

a (name of system) fire extinguishing installation/
 extension(s) designed by,

in accordance with design documentation

and installed in accordance with AS 5062:2016.

Name of client

Equipment being protected (make/model)

Identification number

Fire hazard locations being protected

Type of system

Storage arrangement

Hazard location	Actuation method (automatic/manual)	Agent quantity	No. of containers	No. of nozzles	Applicable drawing(s)

Functional parameters (tick)

Functional interfaces with equipment system Engine shutdown
 Air-handling shutdown Fuel shut-off

Variations from this Standard previously agreed to by the authority having jurisdiction are attached (Clause references and related variations should be listed).

Detection system details:

Detection area	Detection type	No. of points	Circuit material

Actuation system details:

Actuator location	Actuator type	Manual/auto	Circuit material

Suppression system details:

Protected area	Suppression type	No. of nozzles	Delivery material

PART 2: TO BE COMPLETED AFTER TESTING

Commissioning test(s) conducted by
..... Date

Commissioning test(s) witnessed by
..... Date

Discharge test conducted by
..... Date

Discharge test witnessed by
..... Date

Remarks
.....
.....
.....

Licensed to PT Indonesian Fire Equipment Systems - Corporate Copy on 14-Nov-2018. 1 user personal license only. Copying, copy/pasting, storage & distribution or use on network prohibited.
Get permission to copy from or network this publication www.saiglobal.com/licensing

APPENDIX H
FIRE PROTECTION SYSTEM—SAMPLE ANNUAL SYSTEM
CONDITION REPORT

(Informative)

ANNUAL SYSTEM CONDITION REPORT

I (Name).....

of (Company)

of (Address)

I hereby certify that the fire suppression system, fitted to equipment described below has had its annual maintenance inspections and discharge tests completed in accordance with Section 11 of AS 5062:2016 as per the attached system activity reports for the period XX/XX/XXXX. With the exception of items detailed below in 'system defects', the system has been found to be functioning correctly and capable of performing to AS 5062:2016 and the design Standards nominated.

(Signature).....

Name of client

Equipment being protected (make/model)

Identification number

System discharged? Y/N (circle)

Pass/fail? (circle)

Adequate coverage

Discharge time

Additional Remarks:

.....

Signature of installer

Position

Date.....

Accreditation No.

Licensed to PT Indonesian Fire Equipment Systems - Corporate Copy on 14-Nov-2018. 1 user personal license only. Copying, copy/pasting, storage & distribution or use on network prohibited. Get permission to copy from or network this publication www.saiglobal.com/licensing

AMENDMENT CONTROL SHEET**AS 5062:2016**

Amendment No. 1 (2017)

CORRECTION

SUMMARY: This Amendment applies to Clause 11.3.2.

Published on 20 April 2017.

NOTES

NOTES

NOTES

Standards Australia

Standards Australia develops Australian Standards® and other documents of public benefit and national interest. These Standards are developed through an open process of consultation and consensus, in which all interested parties are invited to participate. Through a Memorandum of Understanding with the Commonwealth Government, Standards Australia is recognized as Australia's peak non-government national standards body.

For further information visit www.standards.org.au

Australian Standards®

Committees of experts from industry, governments, consumers and other relevant sectors prepare Australian Standards. The requirements or recommendations contained in published Standards are a consensus of the views of representative interests and also take account of comments received from other sources. They reflect the latest scientific and industry experience. Australian Standards are kept under continuous review after publication and are updated regularly to take account of changing technology.

International Involvement

Standards Australia is responsible for ensuring the Australian viewpoint is considered in the formulation of International Standards and that the latest international experience is incorporated in national Standards. This role is vital in assisting local industry to compete in international markets. Standards Australia represents Australia at both the International Organization for Standardization (ISO) and the International Electrotechnical Commission (IEC).

Sales and Distribution

Australian Standards®, Handbooks and other documents developed by Standards Australia are printed and distributed under licence by SAI Global Limited.

For information regarding the development of Standards contact:

Standards Australia Limited
GPO Box 476
Sydney NSW 2001
Phone: 02 9237 6000
Email: mail@standards.org.au
Internet: www.standards.org.au

For information regarding the sale and distribution of Standards contact:

SAI Global Limited
Phone: 13 12 42
Email: sales@saiglobal.com

