

### **ASSEMBLY INSTRUCTION**

1. Thread (A) into (B) 3/8" dp.
2. Bolt (F) onto (B)'s using (E)'s.
3. Slide (C) over (A)'s.
4. Tip: At this point find the location in boat and mount with (H) screws
5. Thread (D)'s into (A)'s.
6. Bolt on (C) with (G)'s.

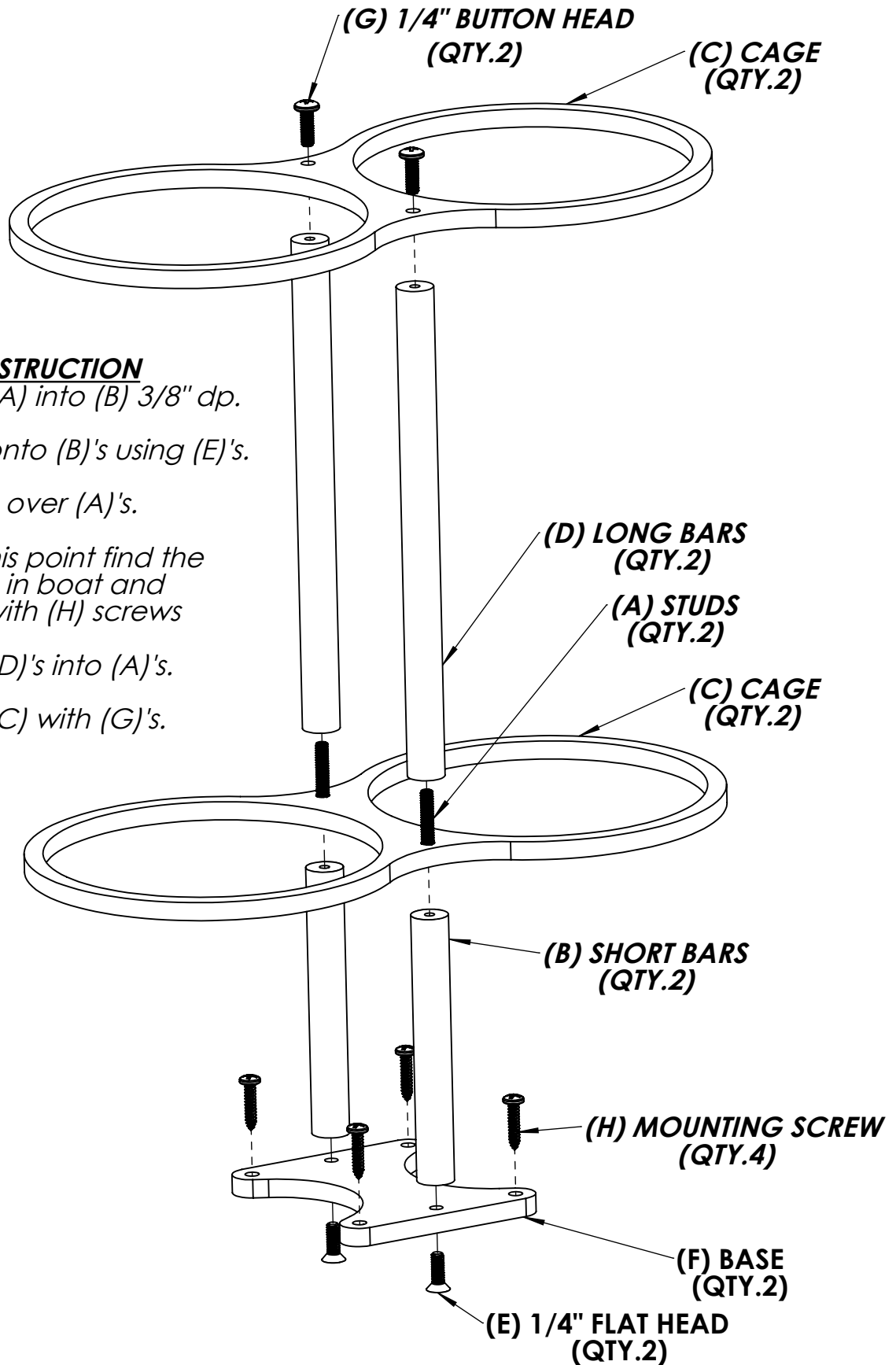

**FIGURE #1**