

CL Challenger Lifts

Installation, Operation & Maintenance Manual Two Post Surface Mounted Lift

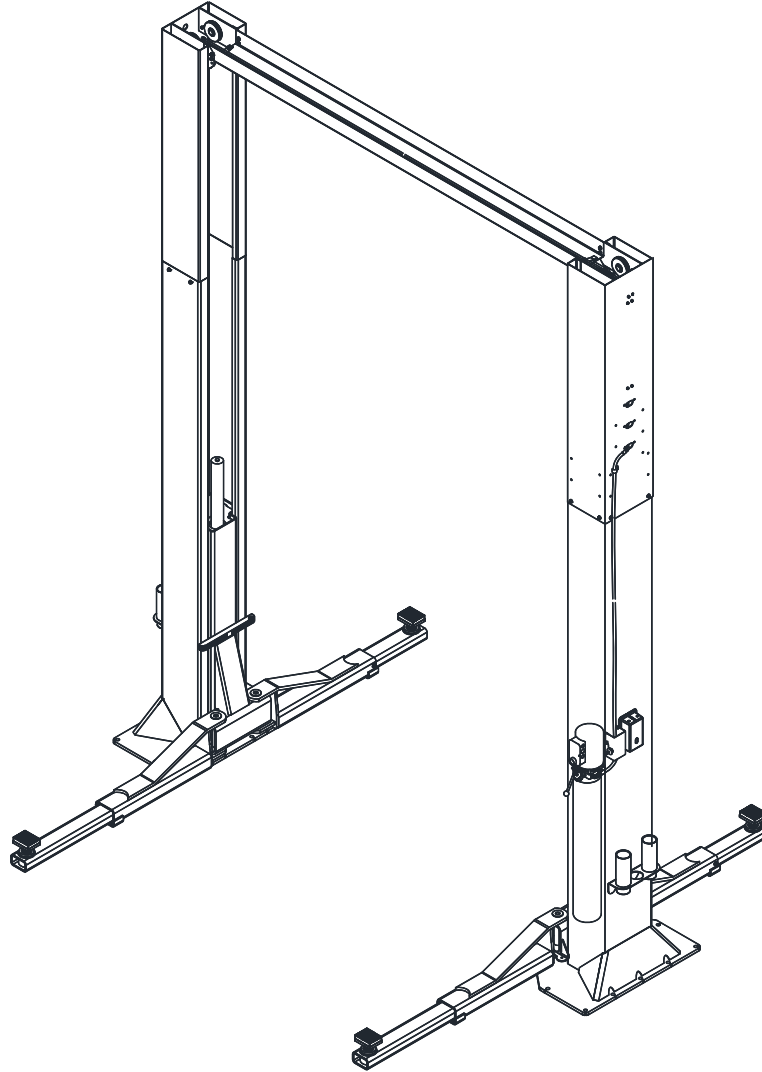

MODELS CL20

20,000 LBS CAPACITY - 5000 LBS PER ARM

2311 South Park Rd Louisville, Kentucky 40219

Email: sales@challengerlifts.com Web site: www.challengerlifts.com

Office 800-648-5438 / 502-625-0700 Fax 502-587-1933

**IMPORTANT: READ THIS MANUAL COMPLETELY BEFORE
INSTALLING or OPERATING LIFT**

GENERAL SPECIFICATIONS

See Figure 1	CL20-0			CL20-2		
	STD	-6"	-12"	STD	-6"	-12"
A Column Height	174" [14'-6"]	168" [14'-0"]	162" [13'-6"]	198" [16'-6"]	192" [16'-0"]	186" [15'-6"]
Ceiling Height Required	176"	170"	164"	200"	194"	188"
B Floor to Overhead Switch	167"	161"	155"	191"	185"	179"
C Max Rise Height w/ Stack Adapters (Screw Pads Only)	84 9/16" (76 9/16")					
D Screw Pad Height	6 3/16" to 7 9/16"					
Stack Adapter Height	4" & 8"					
E Overall Width (STD, -6", -12")	166 3/4", 160 3/4", 154 3/4",					
F Inside of Columns	132", 126", 120"					
G To Nearest Obstruction	7' 6"; 7' 3", 7'					
Drive Thru Clearance	116 1/4", 110 1/4", 104 1/4"					
Arm Reach (Min.-Max.)	38 1/2" - 62"					
* Lifting Capacity (Hydraulic Pressure at Cap.)	20,000 lbs [5000 lbs. Per Arm] (2650 psi)					
** Rise Time	62 Sec. (approximate)					
Motor	3Hp, Single Phase, 60Hz, 208/230V Optional- 2Hp, 3 Phase, 60Hz, 208/230/460V					
Lift Approximate Weight	2460 lbs.					

* Lift capacity ratings are based on loads equally distributed on all four arms.

** Lifting and lowering speeds may vary depending on the weight of the vehicle.

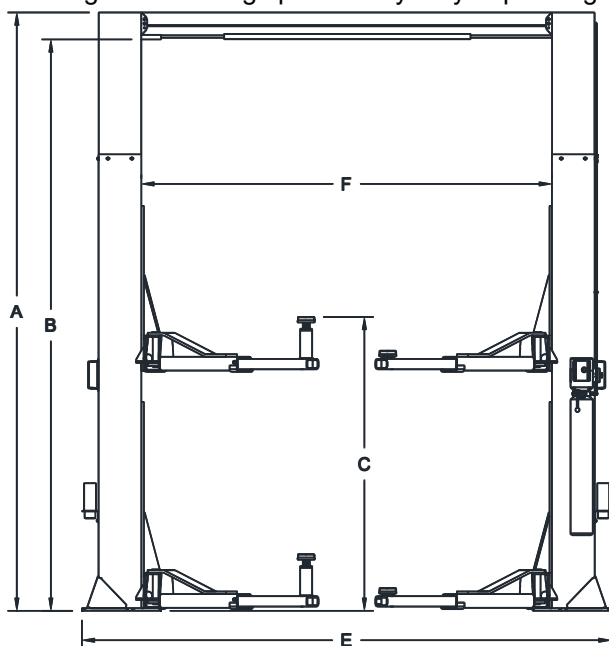

Fig. 1a- General Specifications

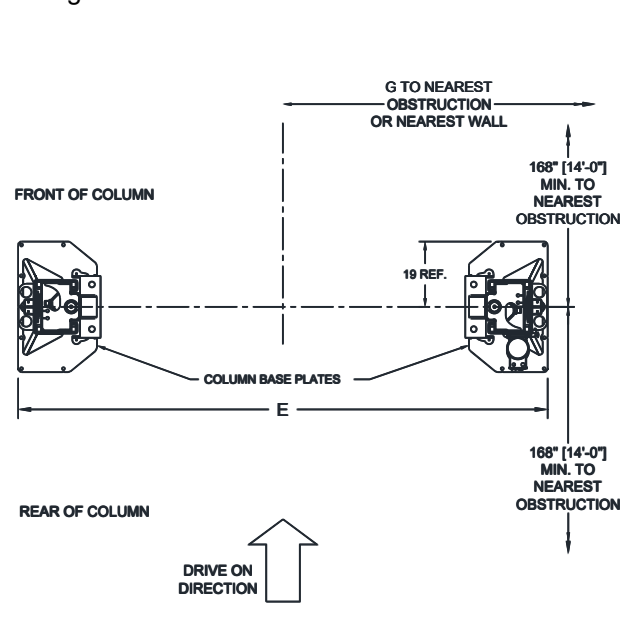

Fig. 1b- Service Bay Layout

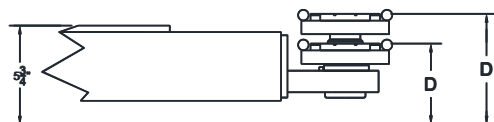

Fig 1c- Arm and Pad Height
WITHOUT STACK ADAPTERS

VERTICAL CLEARANCE

Check the height of the area where the lift is to be installed. Clearance should be calculated based on the full raised height of the lift.



Failure by purchaser to provide adequate clearance could result in unsatisfactory lift performance, property damage, or personal injury.

FLOORING

Be certain the concrete floor can properly handle the loaded lift. Floor should be in generally good condition with no large cracks, spalling or deterioration.

Minimum requirements for concrete are 4 inches minimum depth, with steel reinforcement, 3500 psi, cured for 28 days per local commercial practice. Floor should be level within 3/8 inch over the installation area. No anchors should be installed within 8 inches of any crack, edge, or expansion joint. If these conditions cannot be met, a pad may be poured to accommodate the lift.

Check with local building inspectors and/or permits office for any special instructions or approvals required for your installation.

A qualified person should be consulted to address seismic loads and other local or state requirements.



Failure by purchaser to provide the recommended mounting surface could result in unsatisfactory lift performance, property damage, or personal injury.

LOCATION

This lift has been evaluated for indoor use only with an operating ambient temp. range of 5 – 40°C (41–104°F). Outdoor installation is prohibited.

ELECTRICAL REQUIREMENTS

For lift installation and operation, it is necessary to have a dedicated circuit with circuit breaker or time delay fuse. Refer to wiring diagram for circuit sizing.

AIR REQUIREMENTS

This lift is equipped with an air operated lock release system. **The air supplied to the lift must be clean, dry, lubricated, and regulated to 90-120 psi, FRL (Filter/Regulator/Lubricator).** The FRL must be within 30 feet of lift. **Failure to provide clean, dry, lubricated, and pressure regulated air will void warranty on pneumatic components.**

SAFETY NOTICES AND DECALS

For your safety, and the safety of others, read and understand all of the safety notices and decals included here.

READ ENTIRE MANUAL BEFORE ASSEMBLING, INSTALLING, OPERATING, OR SERVICING THIS EQUIPMENT.

PROPER MAINTENANCE AND INSPECTION IS NECESSARY FOR SAFE OPERATION.

DO NOT OPERATE A DAMAGED LIFT.

Safety decals similar to those shown here are found on a properly installed lift. Be sure that all safety decals have been correctly installed on the Power Unit reservoir. Verify that all authorized operators know the location of these decals and fully understand their meaning. Replace worn, faded, or damaged decals promptly.



Do not attempt to raise a vehicle on the lift until the lift has been correctly installed and adjusted as described in this manual.

<p>SAFETY INSTRUCTIONS</p> <p>Read operating and safety manuals before using lift.</p>	<p>SAFETY INSTRUCTIONS</p> <p>Proper maintenance and inspection is necessary for safe operation.</p>	<p>If attachments, accessories or configuration modifications are located in the load path, affect operation of the lift, affect the lift's electrical listing or affect intended vehicle accommodation are used on this lift and, if they are not certified for use on this lift, then the certification of this lift shall become null and void. Contact the participant for information pertaining to certified attachments, accessories or configuration modifying components.</p> <p>SAFETY INSTRUCTIONS</p> <p>www.autolift.org ©2007 by ALL, Inc. ALI/WLSIA01</p>
<p>SAFETY INSTRUCTIONS</p> <p>Do not operate a damaged lift.</p>	<p>The messages and pictographs shown are generic in nature and are meant to generally represent hazards common to all automotive lifts regardless of specific style.</p> <p>Funding for the development and validation of these labels was provided by the Automotive Lift Institute, PO Box 33116 Indiantonic, FL 32903</p> <p>They are protected by copyright. Set of labels may be obtained from ALI or its member companies.</p> <p>© 1992 by ALL, Inc. ALI/WLS101a</p>	

<p>CAUTION</p> <p>Lift to be used by trained operator only.</p>	<p>CAUTION</p> <p>Authorized personnel only in lift area.</p>	<p>WARNING</p> <p>Clear area if vehicle is in danger of falling.</p>	<p>WARNING</p> <p>Position vehicle with center of gravity midway between adapters.</p>
<p>CAUTION</p> <p>Use vehicle manufacturer's lift points.</p>	<p>CAUTION</p> <p>Always use safety stands when removing or installing heavy components.</p>	<p>WARNING</p> <p>Remain clear of lift when raising or lowering vehicle.</p>	<p>WARNING</p> <p>Avoid excessive rocking of vehicle while on lift.</p>
<p>CAUTION</p> <p>Use height extenders when necessary to ensure good contact.</p>	<p>CAUTION</p> <p>Auxiliary adapters may reduce load capacity.</p>	<p>WARNING</p> <p>Do not override self-closing lift controls.</p>	<p>WARNING</p> <p>Keep feet clear of lift while lowering.</p>
<p>The messages and pictographs shown are generic in nature and are meant to generally represent hazards common to all automotive lifts regardless of specific style.</p> <p>Funding for the development and validation of these labels was provided by the Automotive Lift Institute, PO Box 33116 Indiantonic, FL 32903.</p> <p>They are protected by copyright. Set of labels may be obtained from ALI or its member companies.</p> <p>© 1992 by ALL, Inc. ALI/WLS101a</p>		<p>The messages and pictographs shown are generic in nature and are meant to generally represent hazards common to all automotive lifts regardless of specific style.</p> <p>Funding for the development and validation of these labels was provided by the Automotive Lift Institute, PO Box 33116 Indiantonic, FL 32903.</p> <p>They are protected by copyright. Set of labels may be obtained from ALI or its member companies.</p> <p>© 1992 by ALL, Inc. ALI/WLS101a</p>	

RECEIVING

The shipment should be thoroughly inspected as soon as it is received. The signed bill of lading is acknowledgement by the carrier of receipt in good condition of shipment covered by our invoice.

If any of the goods called for on this bill of lading are shorted or damaged, do not accept them until the carrier makes a notation on the freight bill of the shorted or damaged goods. Do this for your own protection.

NOTIFY **Challenger Lifts** AT ONCE if any hidden loss or damage is discovered after receipt.

IT IS DIFFICULT TO COLLECT FOR LOSS OR DAMAGE AFTER YOU HAVE GIVEN THE CARRIER A CLEAR RECEIPT.

File your claim with **Challenger Lifts** promptly. Support your claim with copies of the bill of lading, freight bill, and photographs, if available.

Component Packing List

PART #	QTY/ LIFT	DESCRIPTION
12320-P	1	POWER COLUMN ASS'Y
12320-I	1	IDLER COLUMN ASS'Y
12300	1	OVERHEAD PACK
CL20-HW	1	HARDWARE BOX
12006	1	ARM PACK
12311-0 12311-2	2	COLUMN EXT. ASSY (14'-6" O.A. HT.) COLUMN EXT. ASSY (16'-6" O.A. HT.)
12074	1	OVERHEAD SHUTOFF BAR ASS'Y
B2064-01	1	OVERHEAD LIMIT SWITCH
12302-0 12302-2	2	SYNC. CABLE PACK (14'-6") SYNC. CABLE PACK (16'-6")
B12069	4	ADAPTER EXTENSION (4")
B12068	2	ADAPTER EXTENSION (8")
12091	2	ADAPTER RACK
12093	4	ARM RESTRAINT ASSEMBLY
AB-93178	1	POWER UNIT – SINGLE PHASE
CL20-IOM	1	LITERATURE PACK

ACCEPTED OILS – Do not use oils with detergents
Hydraulic fluid is not provided with the lift shipment

-10 wt. anti-foam, anti-rust hydraulic / biodegradable oil
-Dexron III ATF

Edition of Standards Referenced

Where any ANSI standard is referenced within this manual, the most recent edition approved by the American National Standards Institute, Inc. shall apply.

INSTALLATION

SAFETY REQUIREMENTS FOR INSTALLATION AND SERVICE

Refer to ANSI/ALI ALIS (current edition)

IMPORTANT: Always wear safety glasses while installing lift.

TOOLS (MINIMUM REQUIRED)

- Tape measure, 16ft
- Chalk line
- 4ft level
- 10" adjustable wrench
- Standard open end wrenches 7/16", 1/2", (2) 9/16", (2) 11/16", 3/4"
- 5/16" allen wrench FF
- Needle nose pliers
- Hammer drill with 3/4" diameter carbide tipped bits
- 2 lb hammer
- Torque wrench: 150 foot pounds minimum with 1 1/8" socket
- 12 ft. Step ladder
- Anti-Seize lubricant (for arm pins and foot pad screw threads and stop rings)

LAYOUT

Note:

• This lift can be installed at three different heights and three different widths. The Cable adjustment for the Height variation will be accommodated by the Lower Sheave Bracket. The Cable adjustment for the Width variation will be accommodated by the take-up tube in later steps.

• The height and width must be established before beginning, as this will determine the lower sheave position and cable take up tubes to be used.

- Once the lift location has been established, ensure that the vertical clearance and flooring requirements have been met per page 3.
- See **Fig 1** for the lift layout. Determine which side of the bay that the power unit will be on and identify the column assembly with the power unit bracket. Layout the service bay according to the architect's plans or owner's instructions (**see Fig. 1b**). **Failure to install in this orientation can result in personal and property damage.** Be certain that the proper conditions exist, see pg 3.

LIFT PREPARATION

- With column assemblies lying flat, remove cable and hose rolls from inside the column.
- Manually push carriages up enough to unhook the cylinder hose from the base plate tabs. Proceed with pushing the cylinder and carriage up enough to access all three sheave locations on the sheave bracket, see **Fig 2**.

- 5) Determine the sheave location on the bracket based on Column Extension Height, see Fig 2. **Note: The column has been assembled with the sheave in the highest position on the bracket for the lift installed at STD (max) height.** Reposition the sheave to the middle hole for -6" install height and to the bottom position for -12" install height.

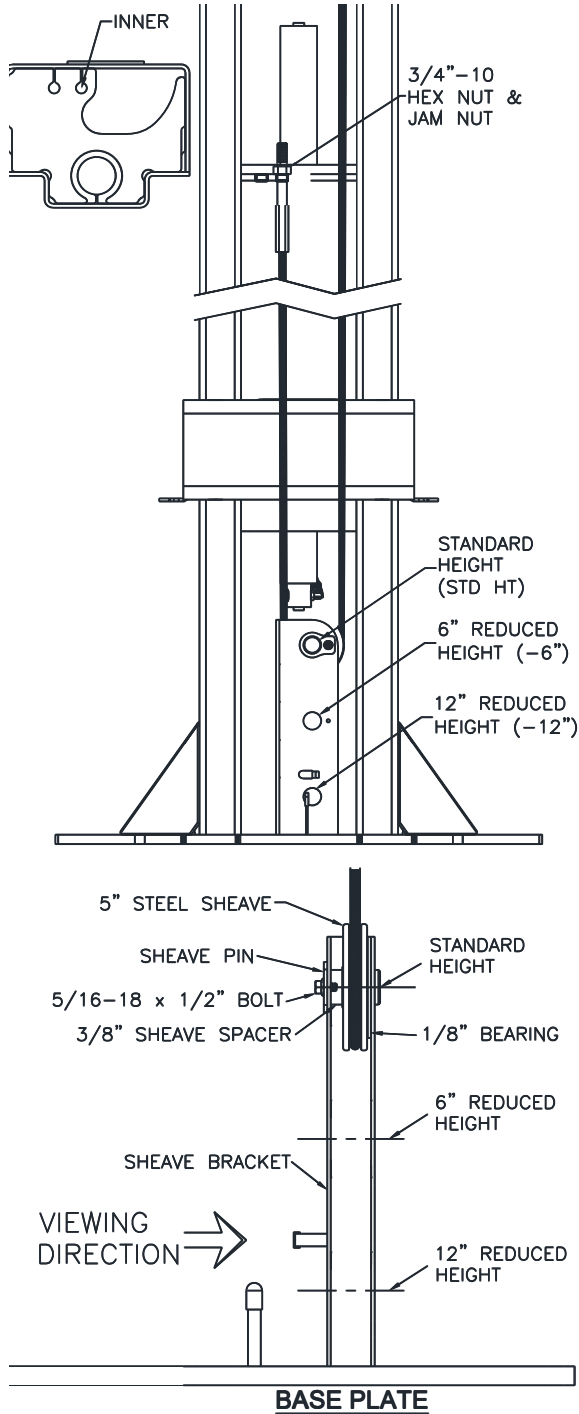

Fig. 2 – Cable Routing

- 6) Remove the bolt, sheave pin, sheave, spacer, and bushing, Fig. 2, to allow the cable to be installed.

- 7) Route a cable through a carriage and out the bottom. Route it back up and into the inside hole at the top of the carriage, see Fig 2. **Ensure cables do not twist or wrap around hoses during routing.**
- 8) Place the 1/8" spacer inside the bracket centered over the bracket hole based on the chosen install height. Install the cable on the sheave and slide into place. Stack the 3/8" spacer onto the sheave assembly. Still holding the sheave assembly, slide the pin into place. Install the bolt to secure the pin, see Fig 2.
- 9) Pull tension on the free end of the cable and ensure proper routing. While pulling tension on the cable, slide the cylinder and carriage down until the carriage is 8" from the baseplate. Slide the hydraulic cylinder down and route the hydraulic hose around the base tabs to prevent rotation of the cylinder. While pulling tension on the cable to avoid kinking, slide the carriage and cylinder down to base of lift.
- 10) Assemble column extension to column by lining up the correct set of holes and using the 1/2"-13 x 1" lg. hex flange head bolts, Fig. 3. **Note: the column extensions are adjustable by 6" and 12".**
- 11) Repeat the cable routing / lower sheave install and the column extension install for the other column.
- 12) Erect and align both column assemblies.

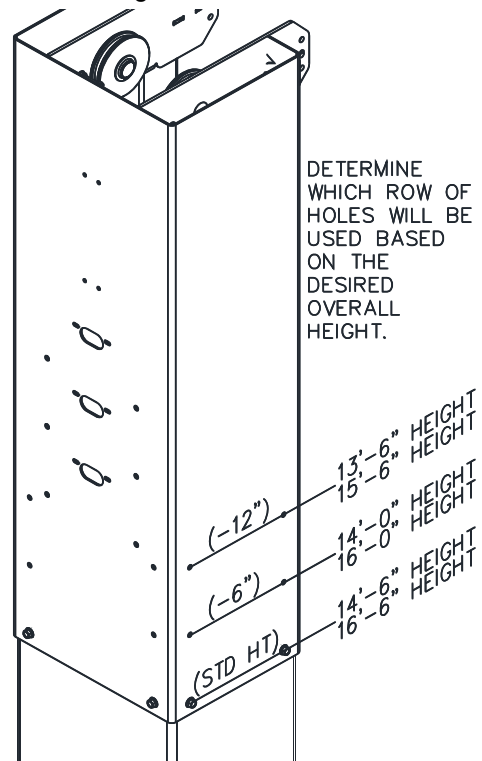

Fig. 3 – Column Extension Assembly

LOCK RELEASE/PAWL

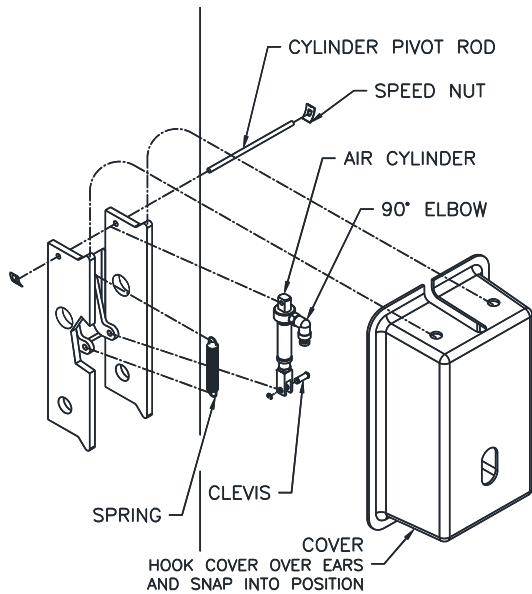

Fig. 4 – Locking Pawl Assembly

- 13) Install the locking pawl, actuator, and spring (**Fig. 4**). Adjust air cylinder clevis to retract lock against inside of back of column when air cylinder is fully extended. Tighten air cylinder clevis jam nut against clevis.

ANCHORING

Note:

- The anchor bolts must be installed at least 8" from any crack, edge, or expansion joint. Recheck the area around both base plates.
- Use a concrete hammer drill with a 3/4-inch carbide bit. Tip diameter should conform to ANSI Standard B212.15 (.775 to .787). Do not use excessively worn bits or bits which have been incorrectly sharpened. A core bit may be necessary if an obstruction is encountered. **Never substitute with shorter anchor.**

- 14) Recheck "Inside of Columns" dimension (**Fig. 1**).
- 15) Using the base plate as a template, drill one anchor hole. Drill through the floor if possible or to a depth of 5 inches minimum.
- 16) Clean the hole inside and out.
- 17) Assemble a washer and nut to the anchor with nut just below impact section of bolt. Drive the anchor into the hole until the nut is 3/4" above the baseplate (leaving room for shims).

Complete steps 15 thru 17 for the seven (7) exposed anchors (one at a time) around each column.

- 18) Raise both carriages (400 lbs. ea.) high enough to drill the two inner anchor holes on each column. Measure both carriage heights to ensure they are in the same lock position.

- 19) **IMPORTANT:** Ensure that the lock pawl is engaged by attempting to manually disengage it. When properly engaged, the weight of the carriage will prevent it from moving.
- 20) Repeat steps 15 thru 17 for the two (2) anchors under each carriage.
- 21) Shim both columns to plumb using the shims provided as shown in **Fig. 5**. **DO NOT** shim more than 1/2" at any given point. Use a level no less than 24" in length to plumb columns.
- 22) Drive all the anchors until nut and washer contact baseplate.

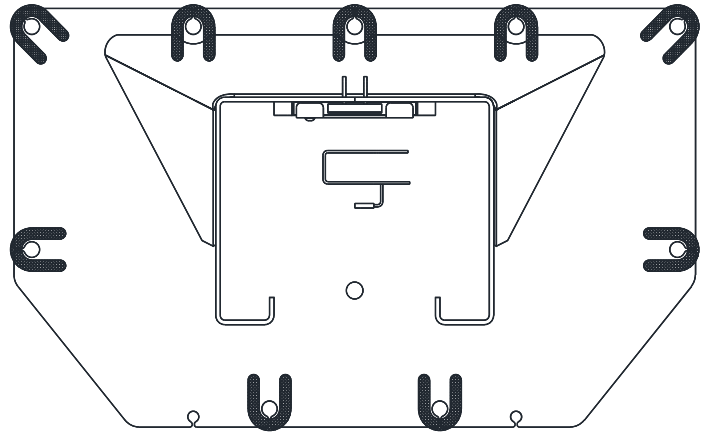

Fig. 5 – Column Shimming

- 23) Tighten Power Column anchors and recheck column for plumb. Re-shim if necessary. Torque to 150-foot pounds to set anchors.
- 24) Loosen Idler Column anchors 1/8" and proceed with the Overhead Beam installation.

OVERHEAD

- 25) Before raising overhead into position, install 4 (2 per column) hex flange bolts and nuts in bottom hole of column extension tab (**see Fig. 6 Installation Aid**) for temporary support of overhead. Lift overhead assembly up into position and install with 8 (4 per column) 1/2-13 x 1" lg hex flange bolts and hex flange nuts per side as shown in **Fig. 6**. For the wide position, the outer overhead holes will be used. For the 6" reduced width, use one set of outer overhead holes and one set of inner overhead holes. For the narrow width, use the inner sets of overhead holes.

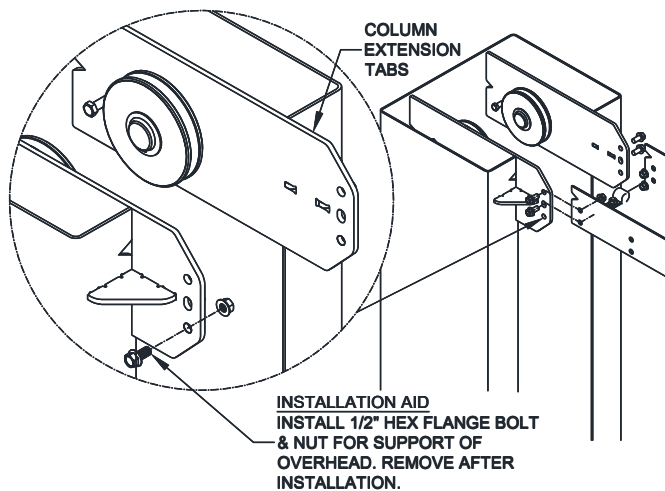

Fig. 6 – Overhead Assembly

- 26) Check idler column shimming. Use additional shims (*see Fig. 5*) to remove any gaps that may have been created while installing overhead beam. Tighten anchor bolts and re-check column for plumb. Torque to 150 foot-pounds.
- 27) Install Overhead Limit Switch to the Overhead Beam using the rear set of holes on the Power Side of the lift. **Fig. 7.**

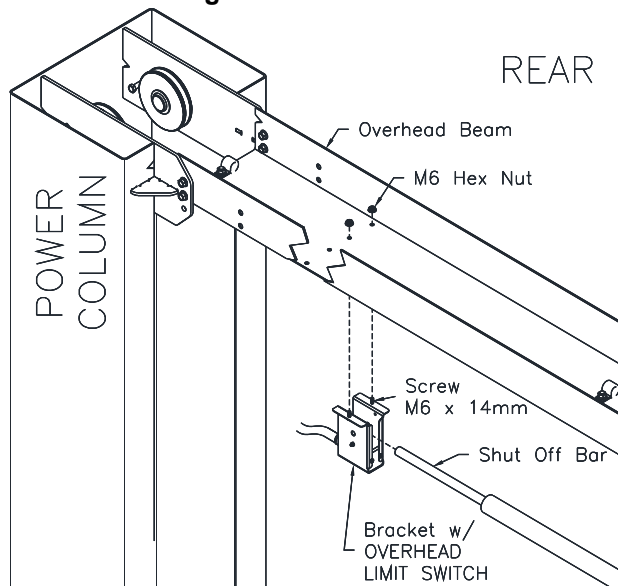

Fig. 7 – Overhead Limit Switch Power Side

- 28) Install the Idler Bracket to the Overhead Beam using the rear set of holes on the Idler Side of the lift. **Fig. 8.** **Note the orientation of the Idler Bracket. The narrow slot needs to be facing towards the Power Column.** Slide the Shutoff Bar over the limit switch on the Power Side. Pin the Shutoff Bar to the Idler Side Bracket with the 10mm dia. x 55mm Lg. clevis pin & hairpin cotter.

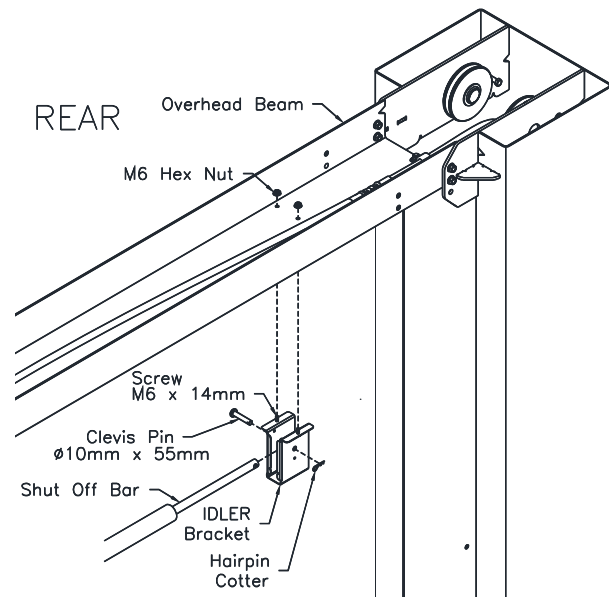

Fig. 8 – Overhead Bracket Idler Side

SYNCHRONIZER CABLES

- 29) Remove Cable Trapping Hardware at the top of each column. **Fig 9.** Route free end of cables coming out the top of the carriage up and over the upper sheaves and back down the opposite side. Do this for both cables and install the cable trapping hardware.

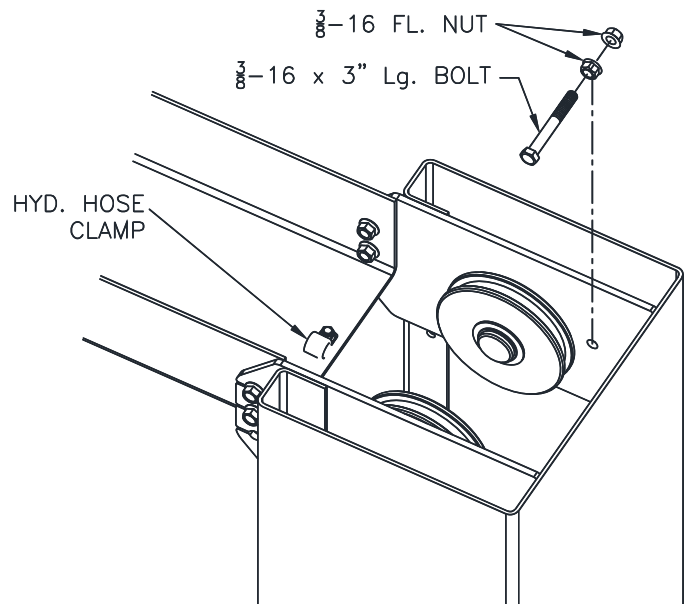

Fig. 9 – Cable Trapping

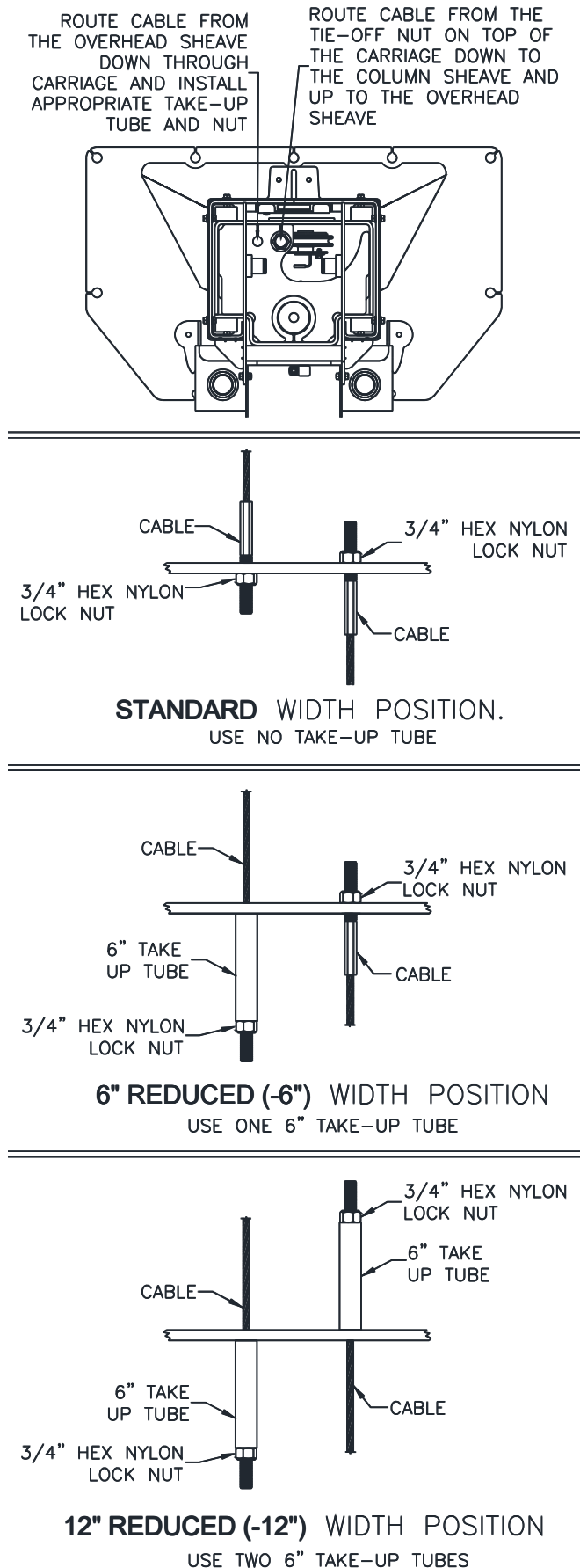

Fig. 10 – Cable Attachment At The Carriage

- 30) Mount synchronizer cables to carriages as shown in **Fig. 10**. **Note: Use the proper Take-Up Tube as shown in Fig 10 based on the width of the lift.**

HYDRAULICS

IMPORTANT: To ensure proper hose fitting seal without damage to the fitting follow this procedure for each hose connection: Screw flared fitting on finger tight. Rotate flared fitting 1 1/2 hex flats (90 deg.). Back the flared fitting off one full turn. Again tighten flared fitting finger tight, then rotate flared fitting 1 1/2 hex flats (90 deg.).

- 31) Mount Power Unit to power column as shown in **Fig 11**. The mounting hardware, (4) 5/16"-18NC hex nuts, are pre-installed on power unit mounting bracket.

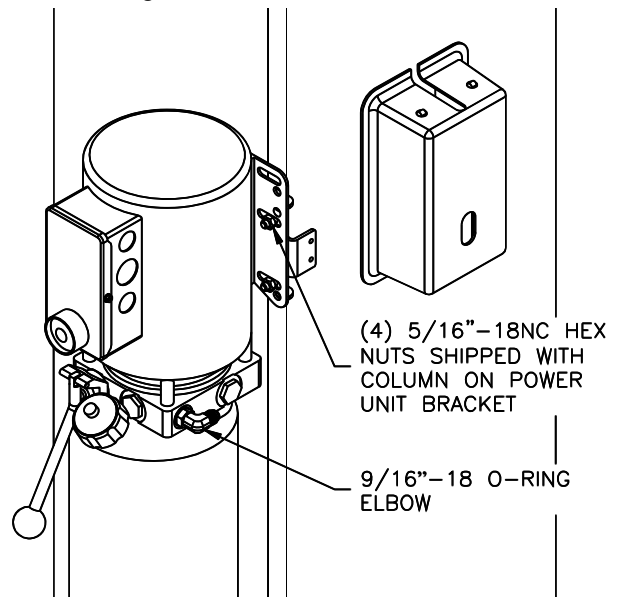

Fig. 11 – Power Unit Mounting

- 32) Install 9/16"-18 O-ring elbow (*in hardware box*) into power unit, **Fig. 11**. **CAUTION** do not damage rubber O-ring.
- 33) Install the block hose clamp bracket onto both column extensions using 1/4"-20NC x 3/4" lg. hex flange bolt and nut, see **Fig 12**.

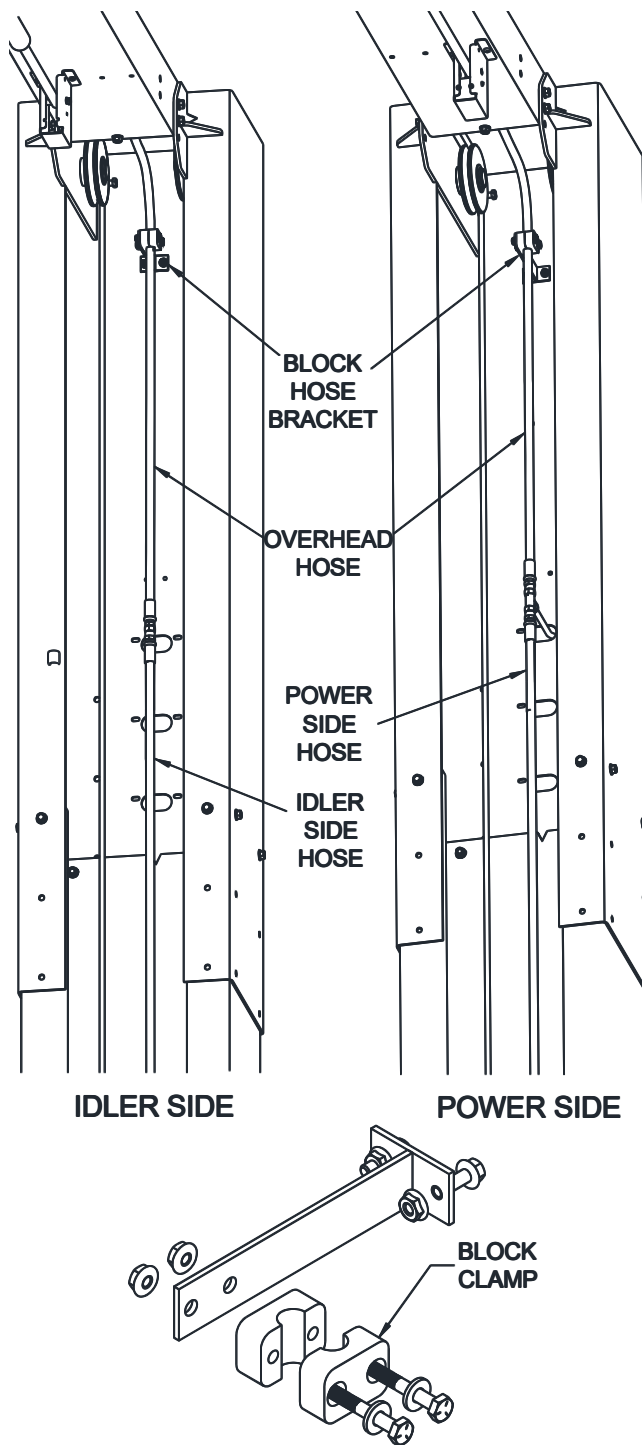

Fig. 12 – Hose Mounting

- 34) Uncoil the Idler Side hose and Overhead hose and attach them together. Route the loose end through Idler Side column extension as shown in **Fig 12**.
- 35) Assemble the block clamp (from hardware box) around the overhead hose, lift the hose assembly to remove the slack, and tighten the clamp.

- 36) Clamp the overhead hose at the idler end of the overhead beam and hold a smooth radius in the hose. (Each hose clamp requires one 3/8"-16NC x 3/4" lg. hex flange bolt and one hex flange nut). Route hose across overhead to the other side. Clamps are not needed yet.
- 37) Uncoil Power Side hose and loosely attach it to the Hydraulic tee fitting (*in hardware box*).
- 38) Bring the Power Unit Hose and Power Side Hose up the column to the lowest available hole of the column extension. Insert steel tubing end of the Power Unit Hose into the extension (outside in) and connect to the tee. Leave the assembly hanging.
- 39) Install a steel line clamp and hose clamp on the outside of the power column extension to secure the power unit hose, as shown in **Fig 13**. (Use 1/4" -20NC x 3/4" lg. hex flange bolt, Spacer, and hex flange nut for steel line clamp. The Spacer goes between the Power Side Column Extension and Line Clamp.) **Note: The steel line inside the column should be horizontal.**

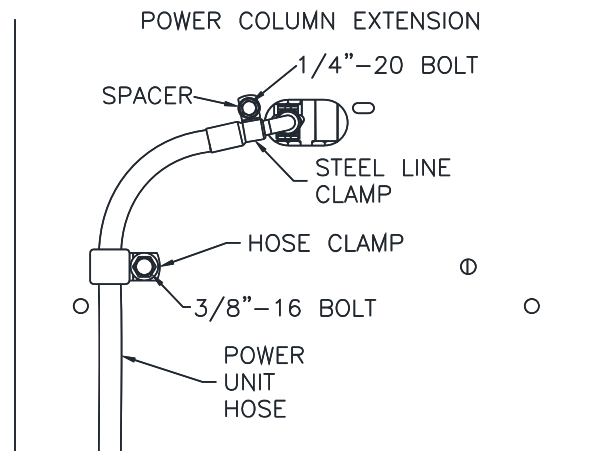
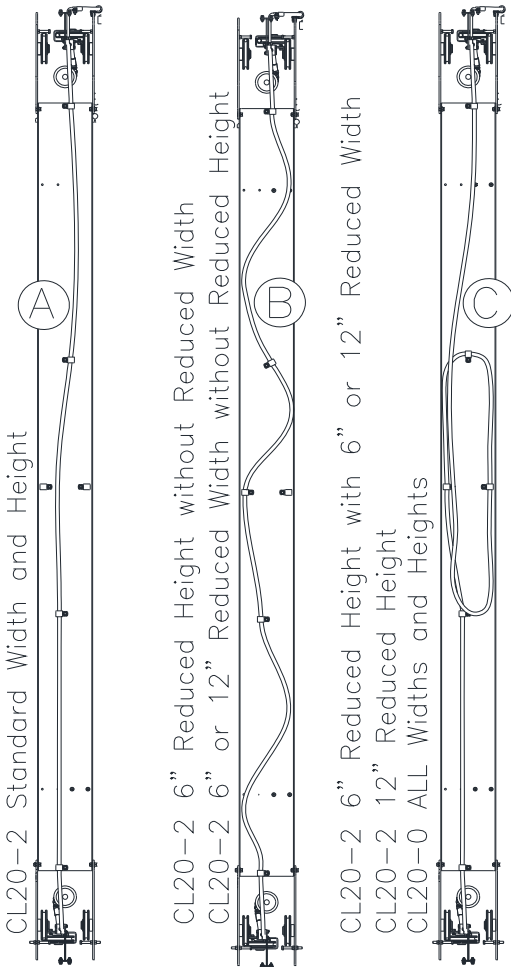

Fig. 13-Power Unit Hose Clamps

40) If installing a CL20-0, use the Routing Diagram C in Fig 14. If installing a CL20-2 use the table in Fig 14 to determine the proper routing diagram A, B, OR C.

HOSE ROUTING DIAGRAMS



HOSE ROUTING TABLE

		CL20-2 WIDTH		
		STD	-6"	-12"
CL20-2 HEIGHT	STD	A	B	B
	-6"	B	C	C
	-12"	C	C	C

Fig. 14 – Overhead Hose Routing Diagram

- 41) Route the overhead hose based on the lifts height and width. To make a loop, twist the hose. Loosely connect the overhead hose to the other end of the tee.
- 42) Tighten the three hose fitting connections at the Tee taking care not to twist or change the lay of any hose. Install and tighten the block clamp on the power side to hold up the connect to the tee, see Fig 12.
- 43) Install a Hose Clamp at the power end of the overhead beam to hold a smooth radius in the hose.
- 44) Install the rest of the overhead hose clamps as shown in Fig 14 depending on the lift configuration.
- 45) Each column hose should connect to its cylinder with a 90-degree elbow rotated up from horizontal and be routed thru the Hose Guide Tabs as shown in Fig. 15.
- 46) Slightly loosen the 90 Degree Fitting jam nut at the bottom of the Power Side Cylinder. Rotate fitting to remove the slack from the power side hose and tighten jam nut. **Note: This is not necessary for the Idler side.**

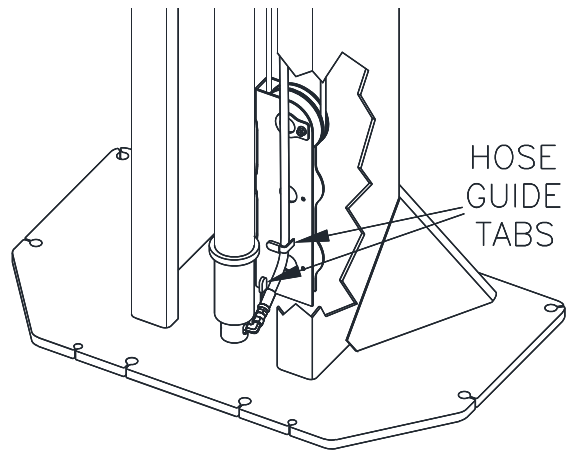

Fig. 15-Hose Connection

- 47) **BE CERTAIN ALL FITTINGS AND CONNECTIONS ARE TIGHT. IT IS THE INSTALLER'S RESPONSIBILITY TO ENSURE SYSTEM IS LEAK-FREE.** Fill the Power Unit with three gallons of clean 10wt anti-foam anti-rust hydraulic oil or Dexron III ATF. **Do NOT USE OILS WITH DETERGENTS.**

LOCK RELEASE

- 48) Assemble the fittings to the air valve, **Fig. 16**, with the barbed fitting (3/8" hose barb x 1/8NPT) in port marked "1", the elbow (1/8" push-lock x 1/8NPT) in port "2", and nothing in the center port "3" (exhaust). **Note: Barbed fitting in port marked "1" may be substituted with 1/8" NPT fitting suitable for the chosen compressed air supply method.**
- 49) Attach the valve to the Power Unit Bracket using two #8-32 x 1 1/4" Lg. Pan Head Screws.
- 50) Cut a piece of the 1/8" O.D. air line 9" long and use it to connect the bottom of the Tee fitting to the elbow, **Fig. 16**.

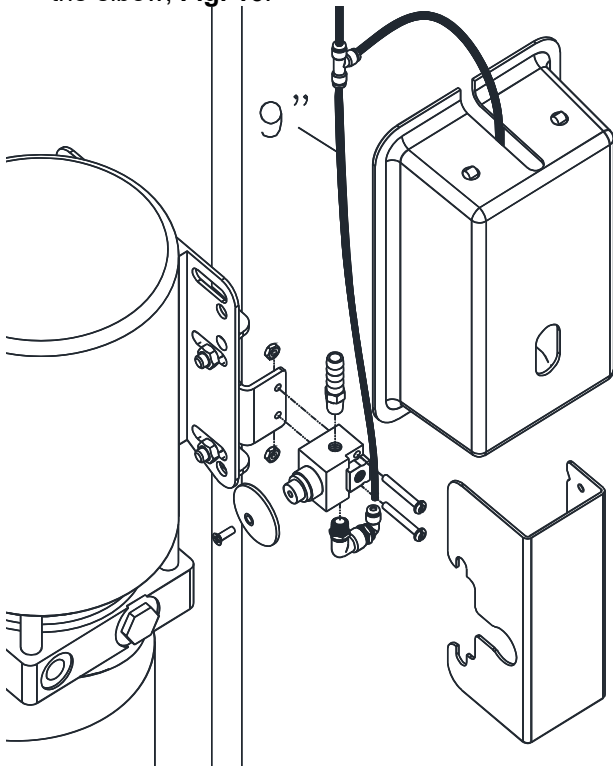

Fig. 16 – Cable Assembly

- 51) Cut to fit a piece of the 1/8" O.D. air line and use it to connect from the lock release air cylinder to the center of the push-lock tee fitting on the Power Column, **Fig 16**.
- 52) Connect the rest of the 1/8" air line to the top of the tee and run it along side the hydraulic hose up the column and across the overhead attaching it to the hydraulic hose with wire ties (**Fig 17**).
- 53) At the Idler side feed the air line thru the lowest large opening in the column extension and down the column.
- 54) Secure the air line to the Idler Column using black wire ties through the double holes in the middle of the column. Place the head of the wire ties inside the column. Cut the air line to length and attach it to the idler side lock release air cylinder (**Fig. 17**).

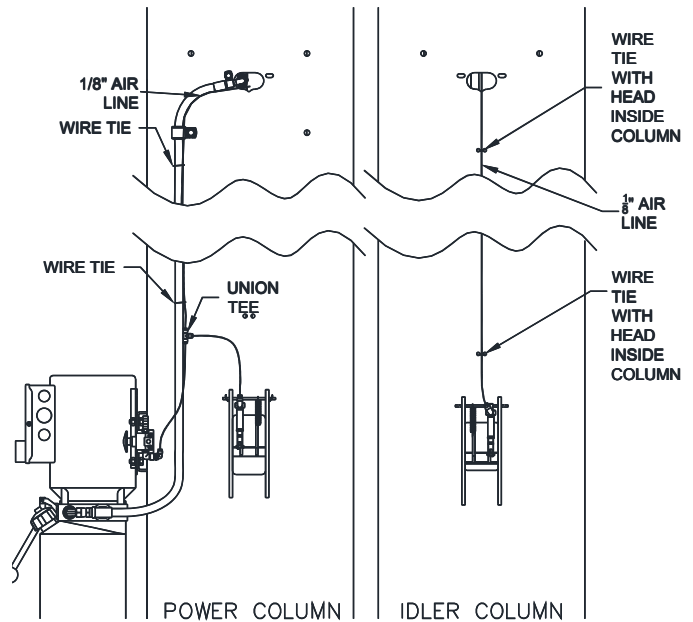

Fig. 17 – Lock Release

- 55) Connect the air valve to the shop's compressed air source, (reference page 3 for Air Requirements), and test the function of the lock release system. Each Column Lock should move freely. When the Air Cylinder is fully extended, the Column Lock should rest firmly against the back of the column.
- 56) Remove the two nuts securing the right side of the power unit, install the valve cover with these nuts, and secure the hose to the cover with black wire ties, **Fig. 18**.

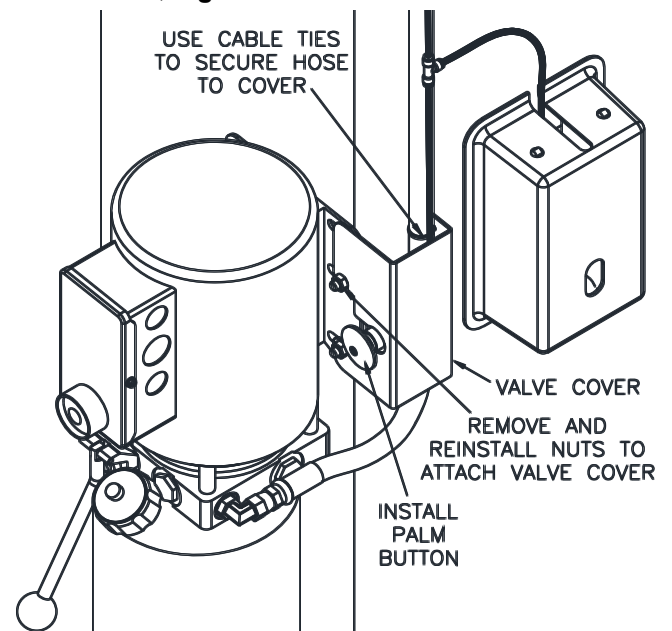

Fig. 18 – Cable Assembly

- 57) Assemble the palm button to the valve.
- 58) Install the Lock Release Covers on the Power and Idler Columns.

ARM INSTALLATION

- 59) Lubricate the arm pin or carriage arm pin hole with “anti-seize” and install the arms. Install the Arm Pin Snap Ring.
- 60) Install the Arm Restraints with the 1/2”-13 Socket Head Cap Screws. Ensure that the arm restraint threads engage and disengage properly. Arm restraints should disengage when lift is fully lowered (**Fig 19**).
- 61) Extend the footpad to both extents and apply “anti-seize” to the retaining ring.

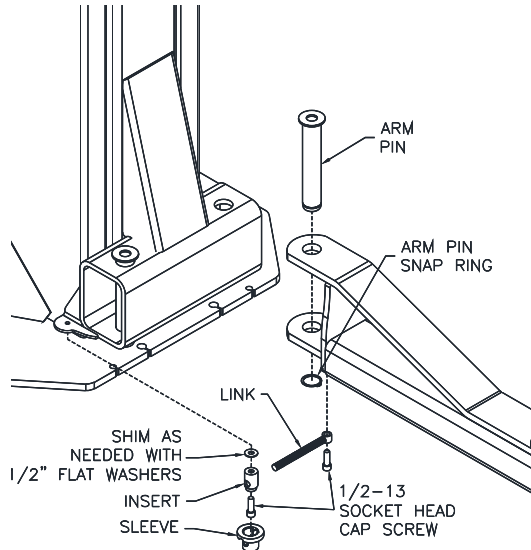

Fig. 19 – Arm Installation

- 62) Make sure all the arm stop screws are tight. Slide all the arms out so they are fully extended making sure that the intermediate is retained in the female and the male is retained in the intermediate arm.
- 63) Locate the two pre-drilled holes on the back of each column 19” up from the top of the base plate. Center the adapter rack and attach with 5/16”-18NC x 1” Lg hex flange cap screw and 5/16” hex flange nut (**Fig.20**).

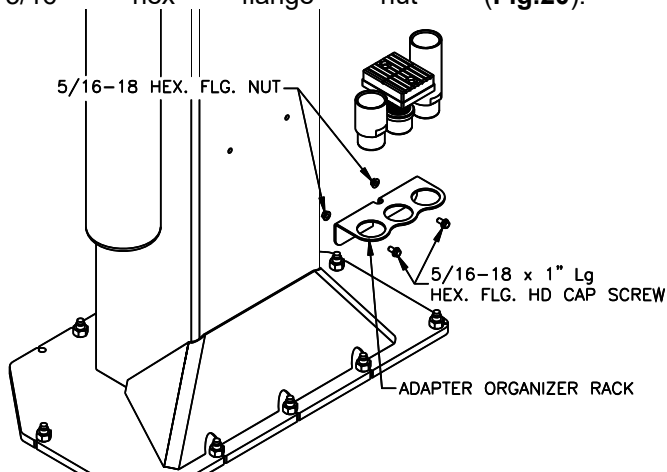

Fig. 20 – Adapter Rack Installation

ELECTRICAL

See Figure 21 for the following steps.

- 64) Wire tie Limit Switch cord to Overhead hydraulic Hose and Power Unit Hose.
- 65) Connect the Overhead Limit Switch Cord to Power Unit
- 66) Connect Power Unit to suitable electrical source.
- 67) Energize the power unit and begin raising the cylinder casings to reengage the carriage.

Note: The air in the cylinders and hoses must be compressed before the cylinders will start to move. Once the cylinders do begin to move, the motion will be erratic.

- 68) Continue raising the cylinders until the top of the Power Side cylinder contacts the top plate of the carriage.

WARNING Do not place fingers inside the carriage.

- 69) Use a socket and extension on the bleed screw at the top of the cylinder to align the cylinder with the hole in the top of the carriage.
- 70) Repeat the previous two steps for the Idler Side cylinder.
- 71) Continue energizing power unit to fully reengage the cylinders with the carriages.
- 72) **IMPORTANT:** TEST OPERATION OF OVERHEAD LIMIT SWITCH. WHILE RAISING LIFT, OPERATE OVERHEAD SHUTOFF BAR. POWER UNIT MOTOR SHOULD STOP WHEN SHUTOFF BAR IS RAISED.

FINAL ADJUSTMENTS

HYDRAULICS

- 73) Lower the lift to the floor and raise the lift approximately one foot.
- 74) Start with Idler side first. Slowly and carefully loosen the bleed plug on top of the cylinder just enough to allow the entrapped air to escape. Repeat for power side.
- 75) Raise lift 6 inches. Repeat the previous step until no air comes out of cylinder.
- 76) Pressure test hydraulic system. Energize power unit, raise lift to full rise and continue to run motor for additional 10 seconds. (NOTE: pressure relief will make a high pitch squeal sound for these 10 seconds.) Check hydraulic system for leaks.
- 77) Energize power unit again for 10 seconds. With a clean rag, wipe down both cylinder rods. (The cylinders are shipped with a small amount of clear anti-corrosive lubricant that will be forced out through the wiper when the lift reaches full rise.) **If lubricant is not wiped clean from the cylinder rod, the cylinder will appear to be leaking.**

SYNCHRONIZING CABLES

- 78) Raise lift and ensure carriages lower into same lock position.
- 79) Adjust synchronizing cables so the tension is equal in both cables and carriages are firmly sitting on locks.
- 80) Cycle lift to ensure that locks operate simultaneously. Adjust if necessary.

FINAL CHECKOUT PROCEDURE

- 81) Demonstrate the operation of the lift to the owner/operator/employer using a typical vehicle and review correct and safe lifting procedures using the **Lifting It Right** booklet as a guide.
- 82) Return all provided literature (including this manual) to the literature pack envelope and deliver the envelope to the owner/operator/employer.
- 83) Complete the online warranty registration (refer to the included warranty statement).

Wiring Diagram

* EACH LIFT SHOULD HAVE A DEDICATED CIRCUIT WITH A DOUBLE POLE (THREE POLE FOR 3 PHASE) BREAKER OR TIME DELAY FUSE SIZED ACCORDING TO THE FOLLOWING CHART.

	1 ϕ 208-240V	3 ϕ 208V	3 ϕ 220-240V	3 ϕ 440-480V
3Hp	30amp	15amp	15amp	5amp

* WIRING MUST COMPLY WITH ALL LOCAL ELECTRICAL CODES.

* ELECTRICAL CODE REQUIRES A SERVICE DISCONNECT FOR THIS DEVICE. WE SUGGEST THIS SERVICE DISCONNECT BE LOCATED NEAR THE POINT OF OPERATION.

FOR SINGLE PHASE

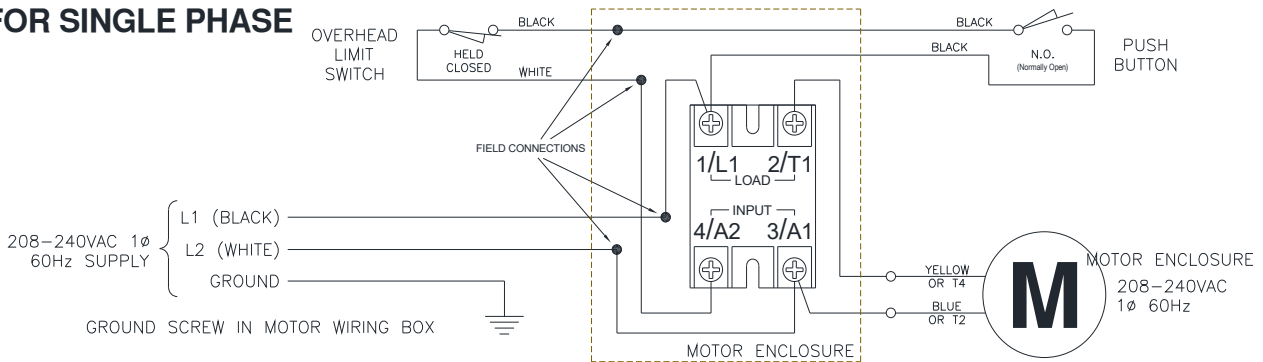

FOR THREE PHASE

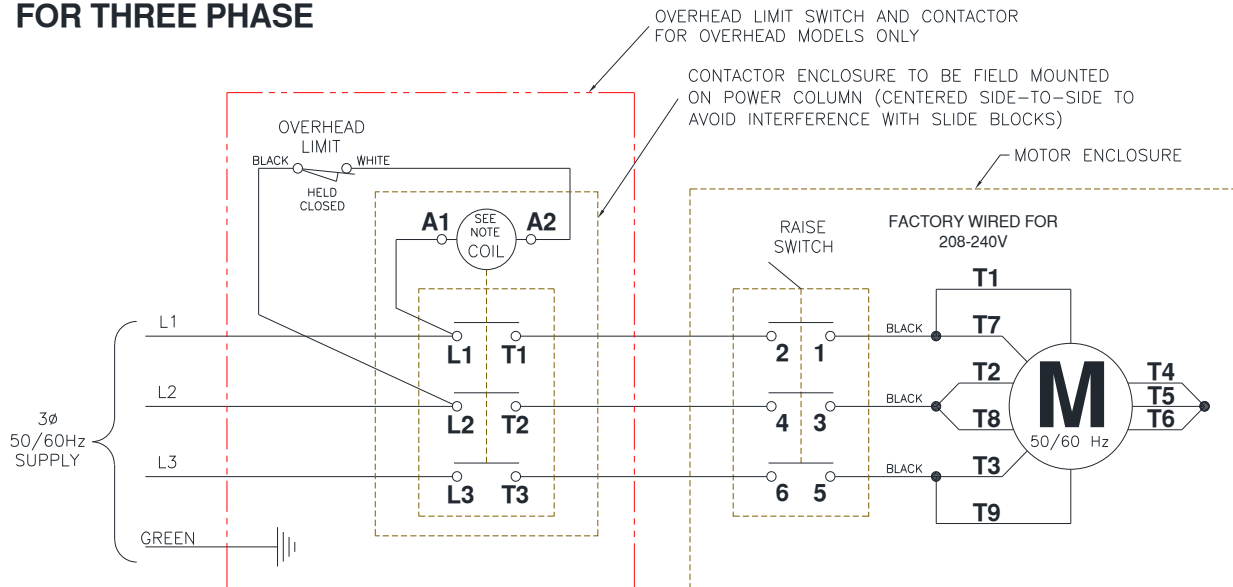

NOTES:

- 1) MOTOR IS FACTORY WIRED FOR 208V OR 220-240V SUPPLY
- 2) MOTOR CONNECTIONS MUST BE RECONFIGURED PER THIS DIAGRAM FOR 440-480V SUPPLY
- 3) CONTACTOR COIL RATING MUST MATCH SUPPLY VOLTAGE (208V, 220-240V, OR 440-480V)
- 4) CONTACTOR MUST BE FIELD MOUNTED ON POWER COLUMN (CENTERED SIDE-TO-SIDE TO AVOID INTERFERENCE WITH SLIDE BLOCKS)
- 5) MOTOR ROTATION IS COUNTER CLOCKWISE FROM TOP OF MOTOR

Fig 21 – Electrical Wiring Diagram

OPERATION PROCEDURE

SAFETY NOTICES AND DECALS

This product is furnished with graphic safety warning labels, which are reproduced on page 3 of these instructions. Do not remove or deface these warning labels or allow them to be removed or defaced. For your safety, and the safety of others, read and understand all of the safety notices and decals included.

OWNER/EMPLOYER RESPONSIBILITIES

This lift has been designed and constructed according to ANSI/ALI ALCTV standard. The standard applies to lift manufacturers, as well as to owners and employers. The owner/employer's responsibilities as prescribed by ANSI/ALI ALOIM, are summarized below. For exact wording refer to the actual standard provided with this manual in the literature pack.

The Owner/Employer shall ensure that lift operators are qualified and that they are trained in the safe use and operation of the lift using the manufacturer's operating instructions; ALI/SM, *ALI Lifting it Right safety manual*; ALI/ST *ALI Safety Tips card*; ANSI/ALI ALOIM, *American National Standard for Automotive Lifts-Safety Requirements for Operation, Inspection and Maintenance*; ALI/WL Series, *ALI Uniform Warning Label Decals/Placards*; and in case of frame engaging lifts, ALI/LP-GUIDE, *Vehicle Lifting Points/Quick Reference Guide for Frame Engaging Lifts*.

The Owner/Employer shall establish procedures to periodically inspect the lift in accordance with the lift manufacturer's instructions or ANSI/ALI ALOIM, *American National Standard for Automotive Lifts-Safety Requirements for Operation, Inspection and Maintenance*; and the employer shall ensure that the lift inspectors are qualified and that they are adequately trained in the inspection of the lift.

The Owner/Employer shall establish procedures to periodically maintain the lift in accordance with the lift manufacturer's instructions or ANSI/ALI ALOIM, *American National Standard for Automotive Lifts-Safety Requirements for Operation, Inspection and Maintenance*; and the employer shall ensure that the lift maintenance personnel are qualified and that they are adequately trained in the maintenance of the lift.

The Owner/Employer shall maintain the periodic inspection and maintenance records recommended by the manufacturer or ANSI/ALI ALOIM, *American National Standard for Automotive Lifts-Safety Requirements for Operation, Inspection and Maintenance*.

The Owner/Employer shall display the lift manufacturer's operating instructions; ALI/SM, *ALI Lifting it Right safety manual*; ALI/ST *ALI Safety Tips card*; ANSI/ALI ALOIM, *American National Standard for Automotive Lifts-Safety Requirements for Operation, Inspection and Maintenance*; and in the case of frame engaging lift, ALI/LP-GUIDE, *Vehicle Lifting Points/Quick Reference Guide for Frame Engaging Lifts*; in a conspicuous location in the lift area convenient to the operator.

IMPORTANT SAFETY INSTRUCTIONS

When using your garage equipment, basic safety precautions should always be followed, including the following:

1. Read all instructions.
2. Care must be taken as burns can occur from touching hot parts.
3. To reduce the risk of fire, do not operate equipment in the vicinity of open containers of flammable liquids (gasoline).
4. Keep hair, loose clothing, fingers, and all parts of body away from moving parts.
5. Use only as described in this manual. Use only manufacturer's recommended attachments.
6. ALWAYS WEAR SAFETY GLASSES. Everyday eyeglasses only have impact resistant lenses, they are not safety glasses.

SAVE THESE INSTRUCTIONS

LIFTING A VEHICLE

- 1) Ensure that the lifting arms are parked, out to full drive thru position.
- 2) Center the vehicle between the columns (left to right) in the service bay and position the vehicle's center of gravity at the midpoint between the columns (fore and aft). NOTE: the center of gravity is based on the weight distribution and is not the same as the center point of the vehicle.

DO NOT EXCEED 4000 POUNDS PER ARM (16K).

DO NOT ATTEMPT TO LIFT THE VEHICLE WITH ONLY TWO ARMS, AS THIS WILL VOID THE WARRANTY

ENSURE THAT THE HIGHEST POINT ON THE VEHICLE WILL CONTACT THE OVERHEAD LIMIT SWITCH BAR.

DO NOT PLACE THE VEHICLE IN THE SERVICE BAY BACKWARDS.

REFER TO THE VEHICLE MANUFACTURERS SERVICE MANUAL, TECHNICAL BULLETINS, "VEHICLE LIFTING POINTS GUIDE" (ALI/LP-GUIDE) OR OTHER PUBLICATIONS TO LOCATE THE RECOMMENDED LIFTING POINTS.

- 3) Position the arms and adapters so all four pads contact the vehicle simultaneously.

The vehicle should remain level during lifting.

- 4) Raise the lift until all four wheels are off the ground. Test the stability of the vehicle by attempting to rock the vehicle. Check adapters for secure contact with vehicle lift points. If the vehicle seems unstable, lower the lift and readjust the arms. If the vehicle is stable, raise the vehicle to a height a few inches above the desired working height.
- 5) Lower the vehicle until the safety locks on both columns engage. The vehicle should remain level when both locks are engaged. If one side engages and the other continues to descend, stop lowering the vehicle, raise it several inches, and try again to engage both locks.

Always lower lift into locks before entering the area beneath the vehicle.

Always use safety stands when removing or installing heavy components.

LOWERING A VEHICLE

- 1) Ensure that the area under the vehicle is clear of personnel and tools.
- 2) Raise the vehicle until both locks are free.
- 3) Disengage the locks by pressing and holding the lock release palm button.
- 4) Lower the vehicle by depressing the lowering valve handle.
- 5) Continue to lower the vehicle until the carriages stop against the base plate. Retract the extension arms and park them.

LOSS OF POWER

If for any reason the lift will not raise off the locks or the locks will not retract, consult factory authorized personnel.

DO NOT OVERRIDE ANY SAFETY FEATURE IN AN ATTEMPT TO LOWER THE LIFT.

MAINTENANCE

To avoid personal injury, permit only qualified personnel to perform maintenance on this equipment. Maintenance personnel should follow lockout/tagout instructions per ANSI Z244.1.

The following maintenance points are suggested as the basis of a routine maintenance program. The actual maintenance program should be tailored to the installation and include a record of each planned maintenance activity and repair maintenance activity performed. Refer to the maintenance section of the ANSI/ALI ALOIM booklet (blue book) provided with the lift.

- If lift stops short of full rise or chatters, check fluid level and bleed both cylinders per Installation Instructions.
- Replace all Safety, Warning or Caution Labels if missing or damaged (**See *Installation instructions page 3.***)

Daily

- Keep lift components clean.
- Check for loose or broken parts.
- Check hydraulic system for fluid leaks.
- Check adapters for damage or excessive wear. Replace as required with genuine Challenger Lifts parts.
- Check lock release activation. Each Column Lock should move freely. When the Air Cylinder is fully extended, the Column Lock should rest firmly against the back of the column.

Weekly

- Check synchronizer cables and sheaves for wear. Replace as required with genuine Challenger Lifts parts.
- Check synchronizer cable tension per Installation Instructions. Adjust if necessary. If both threaded ends of either cable have run out of adjustment, then replace both cables. (Cables should always be replaced in sets.)

Monthly

- Torque concrete anchor bolts to 80 ft-lbs.
- Visually inspect concrete floor for cracks and/or spalling within 12" of base plate
- Check overhead shutoff switch. While raising lift, operate overhead shutoff bar. Power Unit motor should stop when bar is raised.
- Lubricate carriage slide tracks with heavy viscous grease. (Grease all (4) corners of both columns.)

If any problems are encountered, contact your local service representative.

PARTS BREAKDOWN

Fig A. Column Extension & Overhead

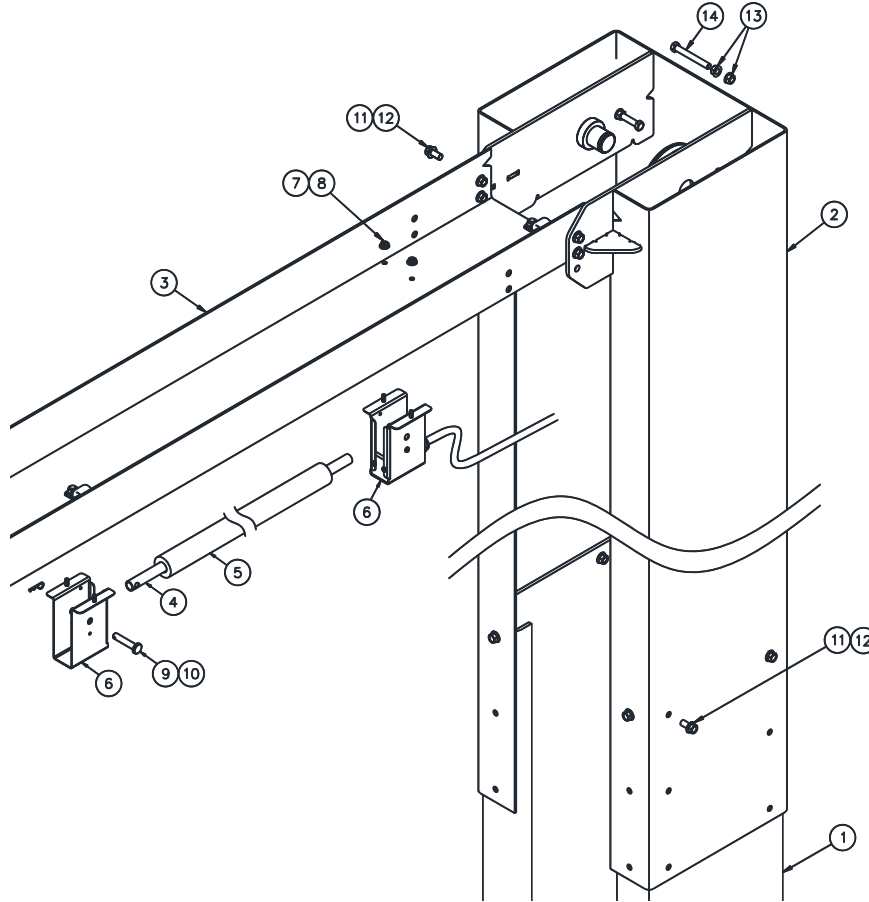

ITEM #	PART #	QTY	DESCRIPTION
1	12321-P	1	POWER COLUMN WELD
	12321-I		IDLER COLUMN WELD
2	12312-0	2	COLUMN EXTENSION WELD (STD Height.)
	12312-2		COLUMN EXTENSION WELD (2ft.)
3	12301	1	OVERHEAD
4	A2067	1	SHUTOFF BAR
5	31129	1	SHUTOFF BAR CUSHION
6	B2064-01	1	LIMIT SWITCH PACKAGE (INCLUDES SWITCH w/ CORD, BOTH BRACKETS, & ITEMS 7-10)
7	B2065-3	4	M6 x 14mm PHILLIPS PAN HEAD SCREW
8	B2065-4	4	M6 SERRATED FLANGE HEX NUT
9	B2065-5	1	CLEVIS PIN 10mm x 55 Lg.
10	GJY12-3	1	HAIRPIN COTTER
11	12330	24	1/2-13NC HEX. FLG. HD. C.S x 1" Lg.
12	12331	24	1/2-13NC HEX. FLG. NUT
13	A1154	8	3/8"-16 HEX FLANGE NUT
14	A2159	4	3/8"-16NC x 3" Lg. HEX HEAD CAP SCREW
	12310-0	1	COLUMN EXTENSION PACK (14'-6" O.A. Ht.) Items (2, 13, 14, 66, 67, 68, 69)
	12310-2		COLUMN EXTENSION PACK (16'-6" O.A. Ht.) Items (2, 13, 14, 66, 67, 68, 69)

Replace all worn, damaged, or broken parts with parts approved by **Challenger Lifts Inc.** or with parts meeting **Challenger Lifts Inc.** specifications.

Contact your local Challenger Lifts Parts Distributor for pricing and availability.
(Call **Challenger Lifts Inc.** (502) 625-0700 for the Parts Distributor in your area)

PARTS BREAKDOWN (continued)

Fig B. Lock-Power/Idler

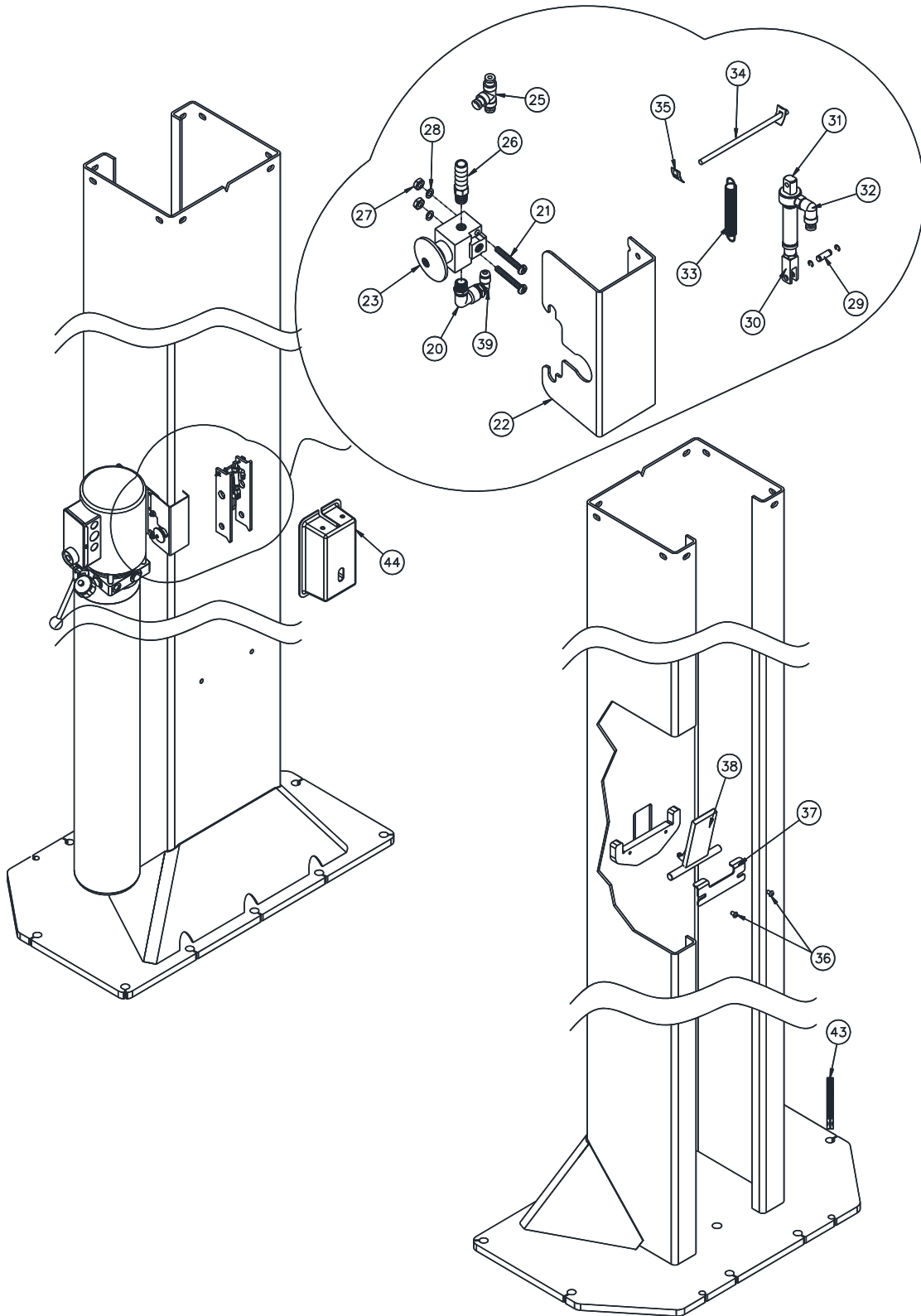

Model CL20
Installation, Operation and Maintenance

TABLE B. Lock-Power/Idler

ITEM #	PART #	QTY	DESCRIPTION
20	37019	1	ELBOW 1/8" NPTM x 1/8" PUSH-LOCK
21	37022	2	#8-32 x 1 1/4" Lg. PAN HEAD SCREW
22	12245	1	AIR VALVE COVER
23	37016	1	AIR VALVE
24	12105	1	Ø1/8" NYLON AIR LINE x 35' Lg.
25	37032	1	1/8" UNION TEE PUSH-LOCK
26	37021	1	HOSE BARB 1/8" NPTM x 3/8" BARB
27	37024	2	#8-32 HEX NUT
28	37023	2	#8 LOCK WASHER
29	37119	2	CLEVIS PIN KIT
30	37120	2	ROD END CLEVIS
31	37026	2	AIR CYLINDER
32	37041	2	SWIVEL ELBOW, 1/8" PUSH-LOCK
33	12088	2	EXTENSION SPRING
34	37042	2	CYLINDER PIVOT ROD
35	37031	4	5/32 SPEED NUT
36	12073	4	5/16"-18 x 1/2" Lg. BUTTON HEAD CAP SCREW
37	12037	2	LOCK RETAINER
38	12033	2	LOCK WELD
39	37019	1	1/8" NPT STREET ELBOW
43	31058	18	ANCHOR BOLT, 3/4" x 5 1/2" Lg
44	37072	2	SNAP ON LOCK COVER

Replace all worn, damaged, or broken parts with parts approved by **Challenger Lifts Inc.** or with parts meeting **Challenger Lifts Inc.** specifications.
Contact your local Challenger Lifts Parts Distributor for pricing and availability.
(Call **Challenger Lifts Inc.** (502) 625-0700 for the Parts Distributor in your area)

PARTS BREAKDOWN (continued)

Fig C. Hydraulics

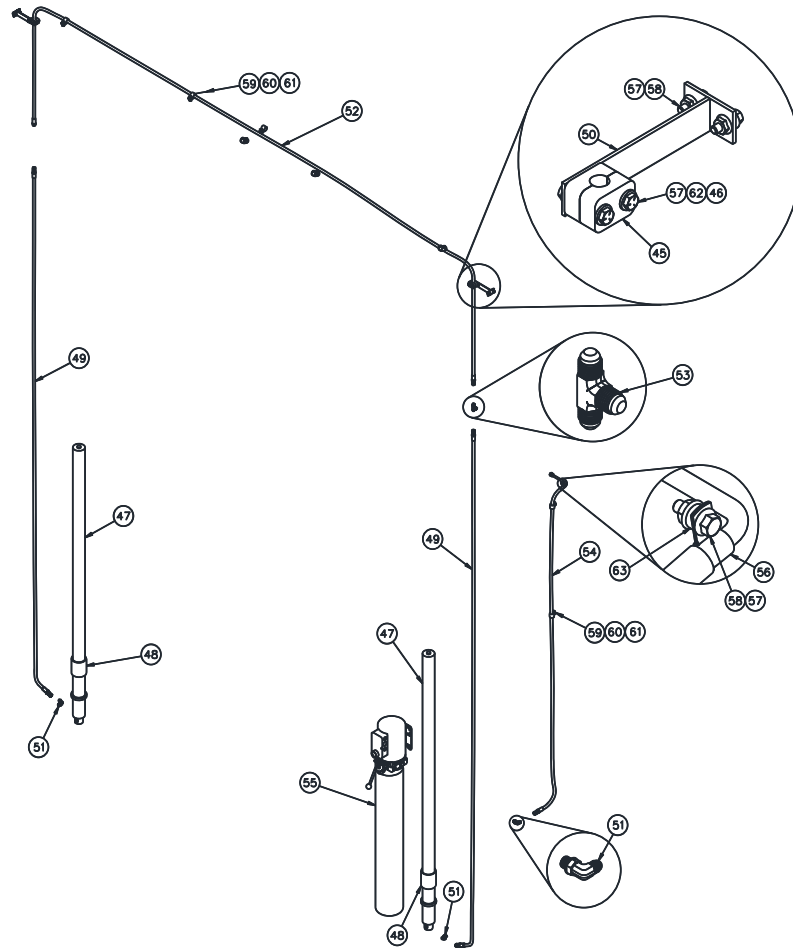

ITEM #	PART #	QTY	DESCRIPTION
45	12332	2	HOSE BLOCK CLAMP
46	40070	4	1/4-20 x 1-3/4 BOLT
47	15075	2	HYD. CYLINDER (69" STROKE)
48	12111	2	CYLINDER SPACER
49	12307	2	COLUMN HOSE ASSEMBLY
50	12750	2	HOSE SUPPORT BRACKET
51	16167	3	O-RING ELBOW
52	12309	1	OVERHEAD HOSE ASSEMBLY
53	39103	1	HYD. TEE
54	12308	1	POWER UNIT HOSE ASSEMBLY
55	AB-93178	1	POWER UNIT –SINGLE PHASE
	AD-93178	1	OPTIONAL POWER UNIT –THREE PHASE
56	31025	1	LINE CLAMP
57	40085	9	1/4"- 20 HEX FLANGE NUT
58	A2125	5	1/4" -20 x 3/4" LG. HEX FLANGE BOLT
59	A1122-12	8	HOSE CLAMP
60	A1153	8	3/8" -16 x 3/4" LG. HEX FLANGE BOLT
61	A1154	16	3/8" -16 HEX FLANGE NUT
62	31115	4	1/4 WASHER
63	12748	1	NYLON SPACER 1/4x1/4

Replace all worn, damaged, or broken parts with parts approved by **Challenger Lifts Inc.** or with parts meeting **Challenger Lifts Inc.** specifications.
Contact your local Challenger Lifts Parts Distributor for pricing and availability.
(Call **Challenger Lifts Inc.** (502) 625-0700 for the Parts Distributor in your area)

PARTS BREAKDOWN (continued)

Fig D. Synchronizer

STANDARD WIDTH

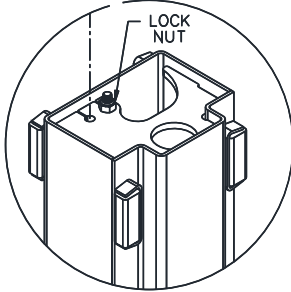

6" REDUCED WIDTH

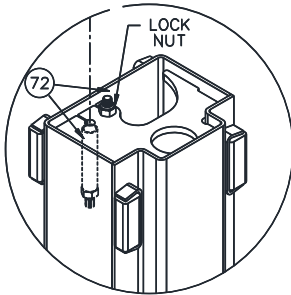

12" REDUCED WIDTH

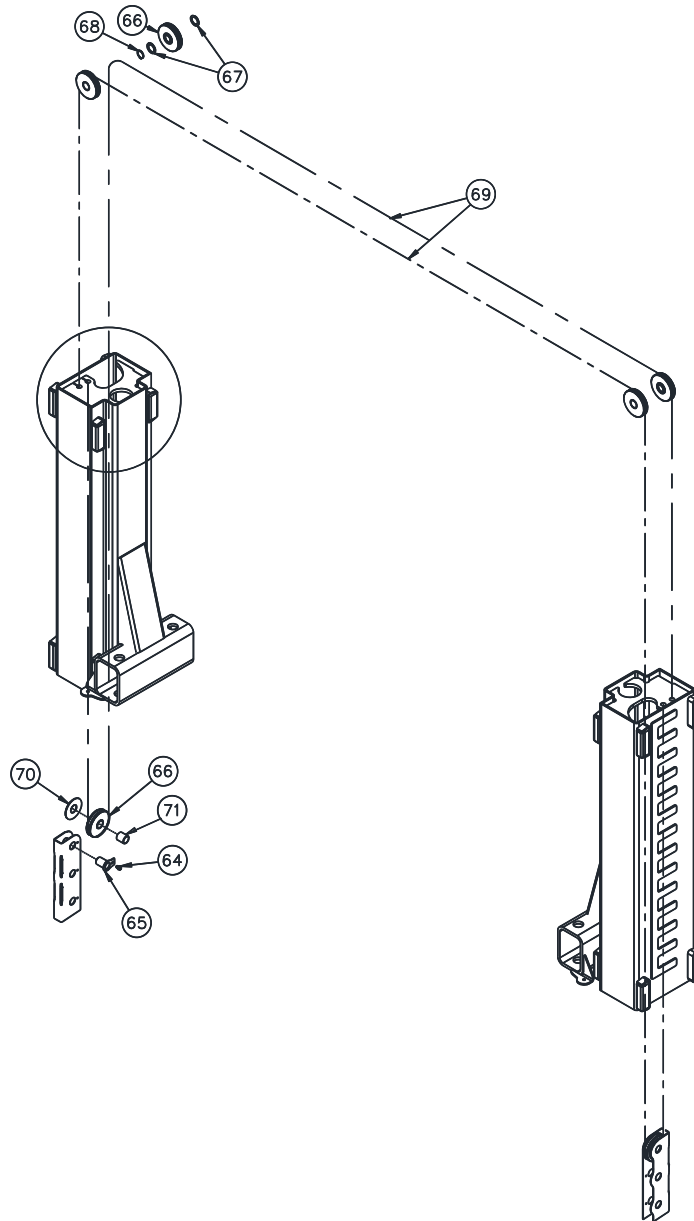
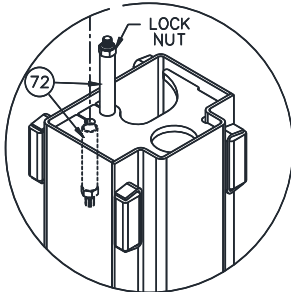

ITEM #	PART #	QTY	DESCRIPTION
64	4100342	2	5/16-18NC x 1/2" Lg. LOCK HEX FLG. HD.CAP SCREW
65	12326	2	SHEAVE PIN
66	CL31019	6	SHEAVE ASSEMBLY
67	CL31020	8	WASHER
68	CL31021	4	1 3/8" RETAINING RING
69	12302-0	1	SYNC. CABLE PACK (14'-6" O.A. Ht.)
	12302-2	1	SYNC. CABLE PACK (16'-6" O.A. Ht.)
70	40053	2	1/8" THICK BEARING
71	40774-S	2	SHEAVE SPACER 3/8"
72	12341	0 / 2 / 4	6" TAKE-UP TUBES [STD HEIGHT: 0 -6: 2 -12: 4]

Replace all worn, damaged, or broken parts with parts approved by **Challenger Lifts Inc.** or with parts meeting **Challenger Lifts Inc.** specifications.

Contact your local Challenger Lifts Parts Distributor for pricing and availability.
(Call **Challenger Lifts Inc.** (502) 625-0700 for the Parts Distributor in your area)

PARTS BREAKDOWN (continued)

Fig F. Carriage & 2-Stage Arms

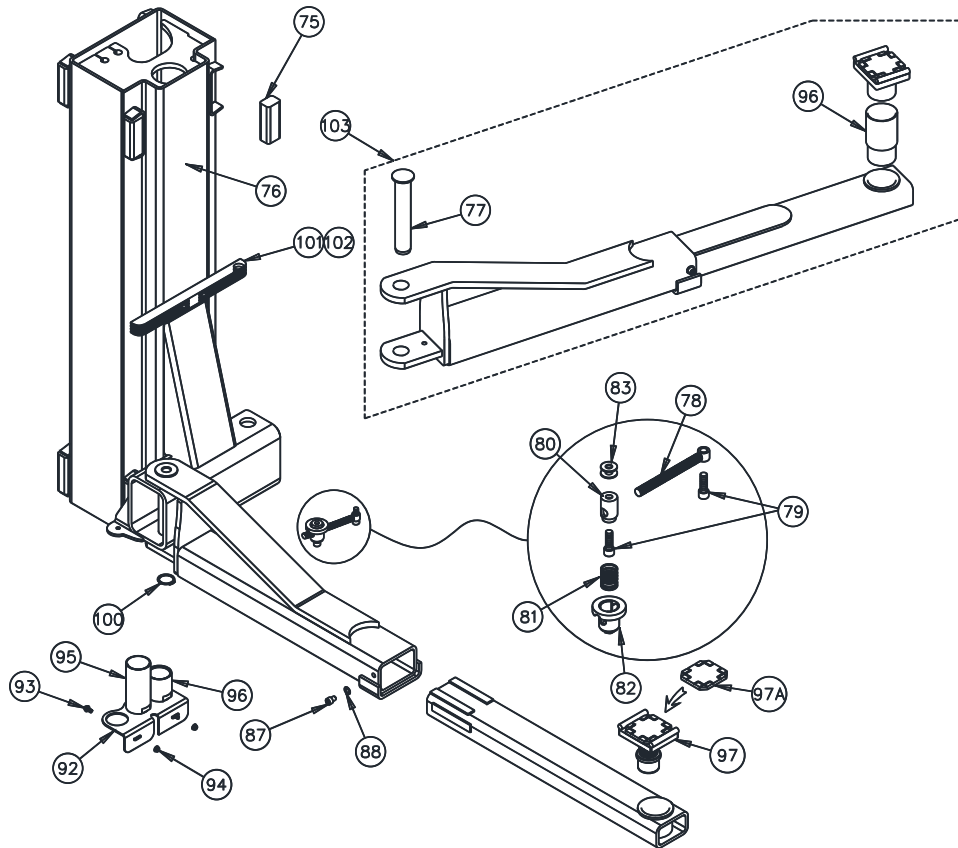

ITEM #	PART #	QTY	DESCRIPTION
75	12021	16	SLIDE BLOCK
76	B12007-18	2	CARRIAGE WELD
77	B12046	4	ARM PIN
78	12060	4	LINK WELD
79	31112	8	1/2"-13NC x 1 1/2" Lg. SOCKET HEAD CAP SCREW
80	31108	4	INSERT
81	31109	4	COMPRESSION SPRING
82	12096	4	SLEEVE WELD
83	31014	12	1/2" FLAT WASHER (SHIM AS NEEDED)
87	12072	4	1/2"-13 x 5/8" SOCKET HD. C.S.
88	12084	4	1/2" INTERNAL TOOTH LOCKWASHER
92	12091	2	ADAPTER RACK
93	A1153	4	3/8"-16NC x 3/4" Lg. HEX. FLG. HD. C.S.
94	A1154	4	3/8"-16NC HEX. FLG. NUT
95	B12068	2	STACK ADAPTER (8")
96	B12069	4	STACK ADAPTER (4")
97	B12162S	4	FOOT PAD ASSEMBLY
97A	A1104-H	4	PAD
100	B1084	4	45mm RETAINING RING
101	B2026-3	2	DOOR GUARD
102	X10-088	4	M8 x 30 SOCKET HEAD CAP SCREW
103	B12048S-1	4	ARM ASSEMBLY, 3-STAGE

Replace all worn, damaged, or broken parts with parts approved by **Challenger Lifts Inc.** or with parts meeting **Challenger Lifts Inc.** specifications.
Contact your local Challenger Lifts Parts Distributor for pricing and availability.
(Call **Challenger Lifts Inc.** (502) 625-0700 for the Parts Distributor in your area)

REVISIONS

2021/08/23 – CREATED FOR NEW PRODUCT RELEASE
2021/11/10 – CORRECT TO NEAREST OBSTRUCTION DIMENSIONS
2022/04/01 – UPDATED CLEVIS BAR ON LOCK DIAGRAMS
2023/11/14 – UPDATED ALL REFERENCED MATERIALS. UPDATED ANCHORING INSTRUCTIONS Pg. 6.
2024/03/15 – ADDED ANSI STANDARDS REFERENCE STATEMENT SECTION. PG. 4