

Machine Loading

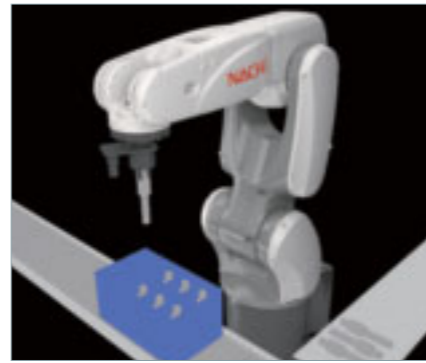

Picking



Packing/Casing



Assembling



Deburring



Finishing



Inspection



Sealing

**NACHI**  
NACHI-FUJIKOSHI CORP.

[www.nachi.com](http://www.nachi.com)

**Tokyo Head Office**  
Shiodome Sumitomo Bldg. 17F 1-9-2 Higashi-shinbashi, Minato-ku, Tokyo 105-0021, JAPAN  
Tel: +81-(0)3-5568-5245 Fax: +81-(0)3-5568-5236

**Toyama Head Office**  
1-1-1 Fujikoshi-Honmachi, Toyama 930-8511, JAPAN  
Tel: +81-(0)76-423-5111 Fax: +81-(0)76-493-5211

**NACHI ROBOTIC SYSTEMS INC.**  
42775 West 9 Mile Road Novi, Michigan, 48375, U.S.A.  
Tel: +1-248-305-6545 Fax: +1-248-305-6542  
URL: <http://www.nachirobotics.com/> E-mail: [Marketing@NachiRobotics.com](mailto:Marketing@NachiRobotics.com)

**NACHI BRASIL LTDA. SAO PAULO BRANCH**  
Av. Paulista, 453, Primeiro Andar, Conj. 11, 12, 13 e 14, Cerqueira Cesar, Sao Paulo-SP, CEP: 01311-000, BRASIL  
Tel: +55-11-3284-9844 Fax: +55-11-3284-1751

**NACHI EUROPE GmbH**  
Bischofstrasse 99, 47809, Krefeld, GERMANY  
Tel: +49-(0)2151-65046-0 Fax: +49-(0)2151-65046-90 URL: <http://www.nachirobotics.eu/>

**NACHI TECHNOLOGY (THAILAND) CO., LTD. BANGKOK SALES OFFICE**  
Unit 23/109(A), Fl.24th Sorachai Bldg., Sukhumvit 63 Road(Ekamai), Klongtonnu, Wattana, Bangkok 10110, THAILAND  
Tel: +66-2-714-0008 Fax: +66-2-714-0740

**PT.NACHI INDONESIA**  
TEMPO PAVILION I, 7FL JL. HR Rasuna Said Kav. 10-11 Setiabudi Jakarta Selatan DKI Jakarta -12950, INDONESIA  
Tel: +62-021-527-2841 Fax: +62-021-527-3029  
URL: <http://www.nachi.co.id/>

**NACHI-FUJIKOSHI CORP. KOREA REPRESENTATIVE OFFICE**  
3F A-Youn Digital Tower, 314-37, Seongsu-dong 2-ga, Seongdong-gu, Seoul, 133-120, KOREA  
Tel: +82-(0)2-469-2254 Fax: +82-(0)2-469-2264

**NACHI KG TECHNOLOGY INDIA PVT. GURGAON HEAD OFFICE**  
Unit No.207, 2nd Floor, Sewa Corporate Park, MG Road, Iffco Chowk, Gurgaon 122001, Haryana, INDIA  
Tel: +91-(0)12-4450-2900 Fax: +91-(0)12-4450-9210

**NACHI (AUSTRALIA) PTY. LTD. MELBOURNE OFFICE**  
38 Melverton Drive, Hallam, Victoria, 3803, AUSTRALIA  
Tel: +61-(0)3-9796-4144 Fax: +61-(0)3-9796-3899  
URL: <http://www.nachi.com.au/>

**NACHI SINGAPORE PTE. LTD.**  
No.2 Joo Koon Way, Jurong Town, Singapore 628943, SINGAPORE  
Tel: +65-65587393 Fax: +65-65587371

- The specifications are subject to changes without notice.
- In case that an end user uses this product for military purpose or production of weapon, this product may be liable for the subject of export restriction stipulated in the Foreign Exchange and Foreign Trade Act. Please go through careful investigation and necessary formalities for export.

CATALOG NO.

R7702E-4

2014.12.U-ABE-ABE

Ultra High Speed and compact

# MZ series

CATALOG



# Characteristics

## Robot body

### Top Perform High Speed\*

\*Combined max speed

#### Top Perform High Speed

- Contributing to improvement of productivity by high speed

Standard Cycle Time Evaluation (go and back) \*1

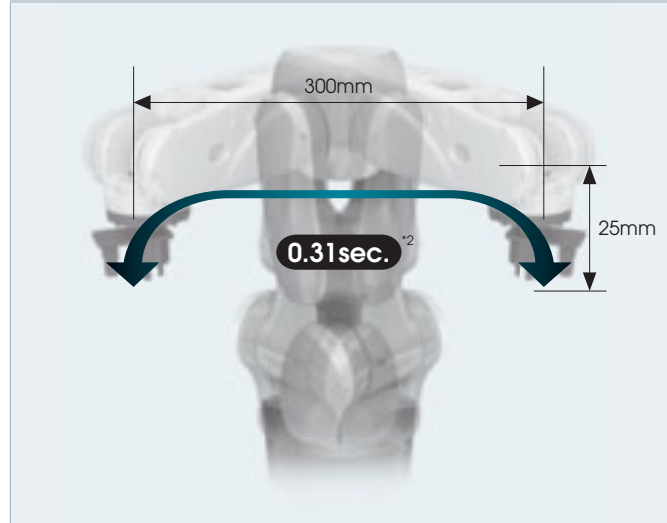

\*1: Payload is 1kg. This may vary according to the robot program and installation.  
\*2: Value for MZ07.

### Smart Cable Routing

#### Cable and tubes can be routed through hollow wrist

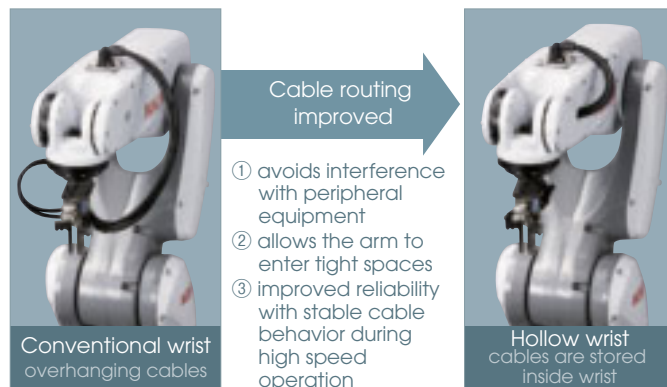

#### Approaching to machine

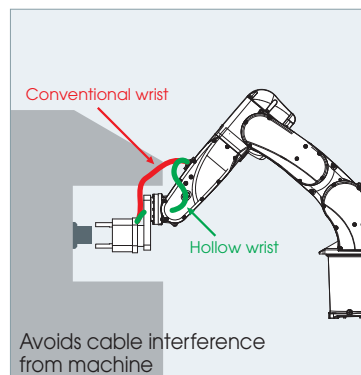

#### Entering into cover

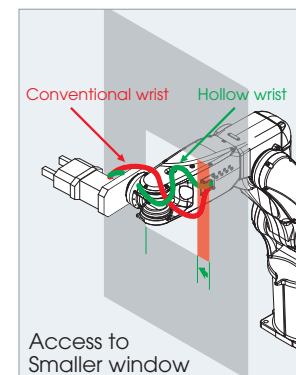

### Compact & Flexible Installation

#### Available to all-round mounting



#### Compact installation space

- Small bottom design enables compact installation

#### Cable connection from bottom side

Option

- More compact installation
- Robot can be installed close to behind wall
- Cables can be stored inside robot riser

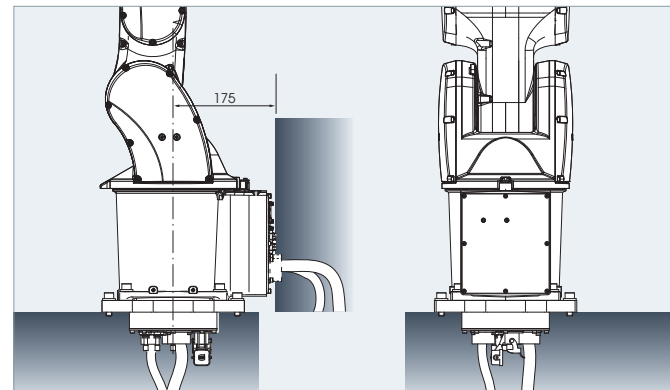
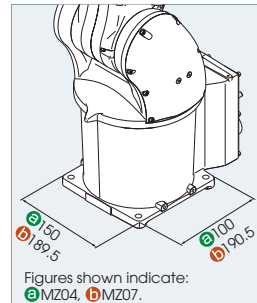

#### Pneumatic Valves inside Robot Arm

Option

- Solenoid valves can be installed inside robot arm

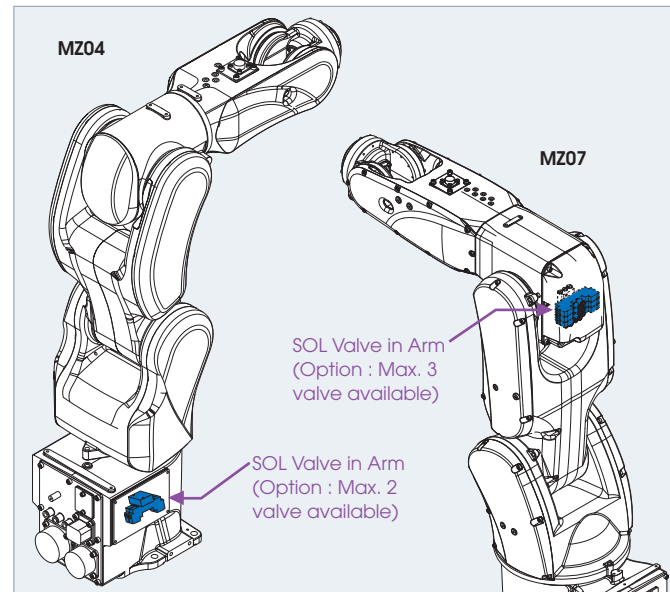

## Controller

### Compact cabinet

- Only 369mm in width
- Could be installed inside robot riser

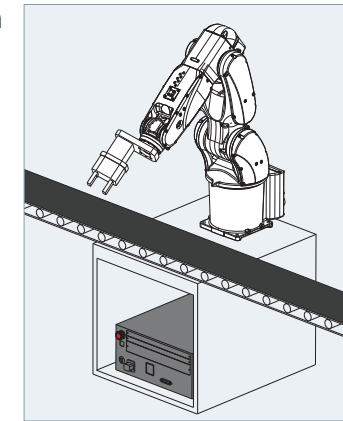

### User friendly functions

#### Software PLC

standard

- Control peripheral equipment by robot controller
- Simplifies system configuration to reduce cost



#### Offline Simulation Tool

standard

#### FD on Desk Light

- Best simulator of first for primary study

- Offline Programming
- Robot Layout Investigation
- Cycle Time Simulation
- PLC Ladder Editing
- Operation Training



#### Field bus

Option

- DeviceNet (Master, Slave)
- EtherNet/IP (Master, Slave)
- CC-Link (Master, Slave)
- PROFIBUS (Master, Slave)
- PROFINET (Slave)

DeviceNet and EtherNet/IP is a trademark of ODVA (Open DeviceNet Vendor Association, Inc.).  
CC-Link is a trademark of CC-Link Partner Association : CLPA.  
PROFIBUS and PROFINET is a trademark of PROFIBUS & PROFINET International.

### Various application

#### Vision Sensor NV-Pro

Option

- Operation by using teach pendant, high speed processing
- Various application available by 2D and 3D vision sensing, dimension measurement and parts type districting



#### Force Sensor

Option

- Assembling (inserting, following, phasing), polishing, deburring

Application example for finishing process.

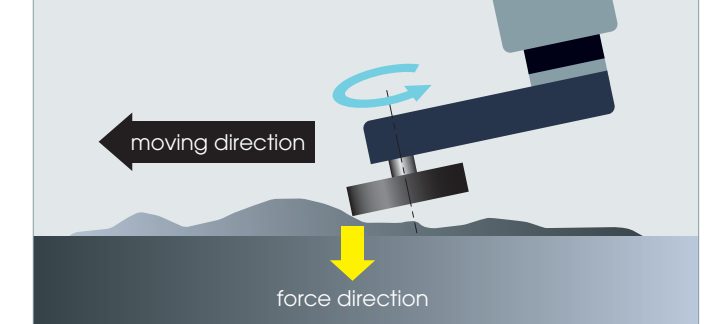

#### Robot Monitoring Unit (RMU)

Option

- Safety unit to monitor robot position and speed
- Reducing cost and space saving

#### User Graphical Interface FlexGui

Option

- Customizing teach pendant display.
- Operator can use teach pendant as a system operating panel.



## Robot type MZ0-01-CFD-0000

Arm variation			
Mark 1	Mark 2	Specification	Notes
4	(none)	4 kg payload, Standard arm	6 axes, Max reach 541mm
	(none)	7 kg payload, Standard arm	6 axes, Max reach 723mm
7	L	7 kg payload, Long arm	6 axes, Max reach 912mm
	P	7 kg payload, Standard arm	5 axes, Max reach 723mm (does not have J4)
	LP	7 kg payload, Long arm	5 axes, Max reach 912mm (does not have J4)

Application variation					
Mark	Specification	Solenoid valve	Signal wires	Notes	
		MZ04	MZ07		
0	Standard	Up to 2	Up to 3	10 wires	
V	Vision sensor	Up to 1	Up to 2	10 wires	LAN cable, Light cable
U	Vision sensor (cross laser)	Up to 1	Up to 1	10 wires	LAN cable, Light cable, Laser cable
F	Force sensor	Up to 1	Up to 1	10 wires	6 freedom Force sensor cable
S	Additional axis	Up to 1	Up to 1	10 wires	1 motor and 1 encoder cable

Installation variation		
Mark	Specification	Notes
0	Standard	J1 working envelope ±30° at wall mounting
W	Wall mount	J1 working envelope ±170° at wall mounting

Connection variation		
Mark	Specification	Notes
0	Rear connection	Robot to controller cable is connected at robot rear
B	Bottom connection	Robot to controller cable is connected at robot bottom

### Basic specification of robot

Item	Specification				
Robot Model	<b>MZ04-01</b>	<b>MZ07-01 (MZ07P-01)</b>	<b>MZ07L-01 (MZ07LP-01)</b>		
Construction	Articulated				
Number of Axis	6	6 (5)			
Drive System	AC Servo drive				
Max. Working Envelope [rad(°)]	Arm	J1 Swivel	±2.97 (±170)		
		J2 Forward/Backward	-2.53 ~ +1.57 (-145 ~ +90)	-2.36 ~ +1.40 (-135 ~ +80)	
		J3 Upward/Downward	-2.18 ~ +4.88 (-125 ~ +280)	-2.37 ~ +4.71 (-136 ~ 270)	-2.43 ~ +4.71 (-139 ~ 270)
	Wrist	J4 <sup>3</sup> Rotation 2	±3.32 (±190)		
		J5 Bend	±2.09 (±120)		
		J6 Rotation 1	±6.28 (±360)		
Max. Speed <sup>4</sup> [rad/s(°/s)]	Arm	J1 Swivel	8.38 (480)	7.85 (450)	5.24 (300)
		J2 Forward/Backward	8.03 (460)	6.63 (380)	4.89 (280)
		J3 Upward/Downward	9.08 (520)	9.08 (520)	6.28 (360)
	Wrist	J4 <sup>3</sup> Rotation 2	9.77 (560)	9.60 (550)	
		J5 Bend	9.77 (560)	9.60 (550)	
		J6 Rotation 1	15.7 (900)	17.5 (1000)	
Max. Payload [kg]	Wrist	4	7		
Allowable Static Loading Torque [N·m]	J4 <sup>3</sup> Rotation 2	8.86	16.6		
	J5 Bend	8.86	16.6		
	J6 Rotation 1	4.9	9.4		
Max. Allowable Moment of Inertia <sup>1</sup> [kg·m <sup>2</sup> ]	J4 <sup>3</sup> Rotation 2	0.2	0.47		
	J5 Bend	0.2	0.47		
	J6 Rotation 1	0.07	0.15		
Max. Reach [mm]		541	723	912	
Position Repeatability <sup>2</sup> [mm]		±0.02		±0.03	
Ambient Temperature		0 ~ 45°C			
Installation		Floor / Wall / Tilted / Inverted mount			
Dust Proof, Drip Proof		IP40 equivalent <sup>5</sup>	IP67		
Robot Mass [kg]		26	30	32	

### Robot dimensions and Working envelope

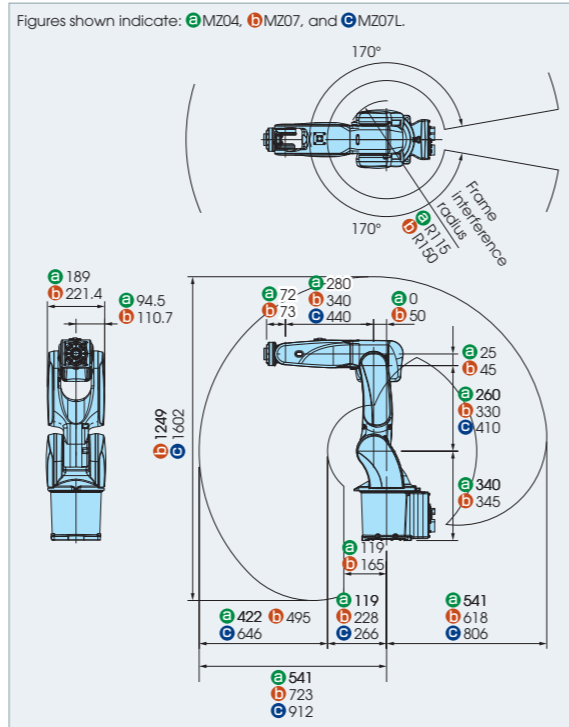

### Connector layout for applications (standard)

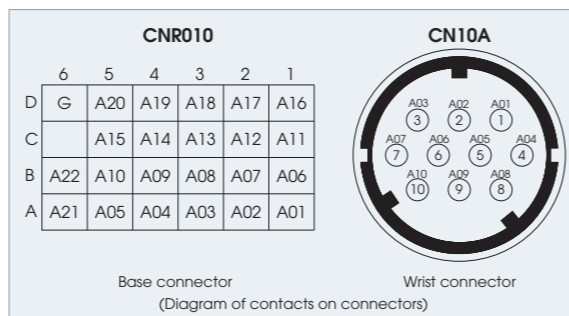

### Wrist dimensions

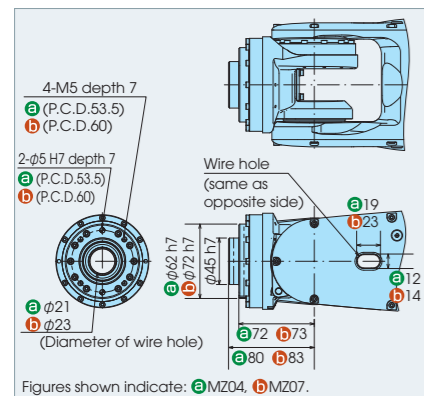

### Robot base dimensions

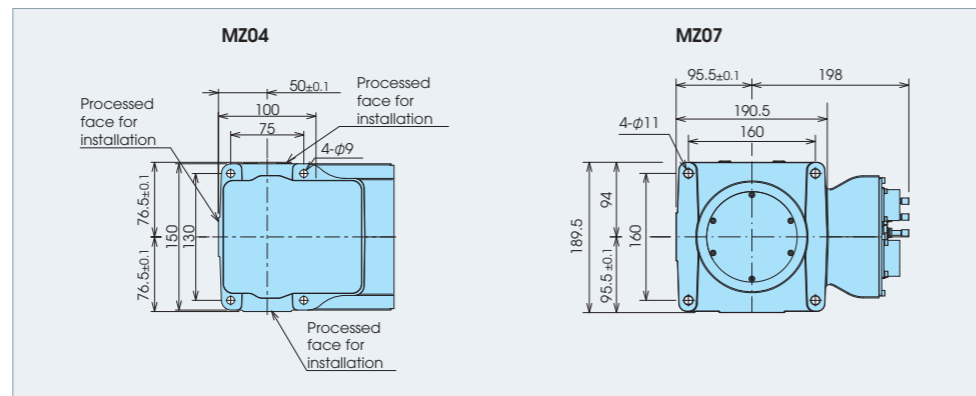

### Basic specification of controller

Item	Specification	
Controlled Axis	6-Axes	
Maximum Control Axis	7-Axes	
Safety Function	PLd Category-3	
Teaching Method	Teach / Playback	
Program Number	9,999 programs	
Memory Capacity	256MB (2,560,000 program steps equivalent)	
Teach Pendant	Smart TP	5.7" Color LCD Touch Panel, Cable Length: 4m
	Compact TP	Monochrome, 20 characters x 4 lines Display, Cable Length: 4m
	Common	3 Position Enable SW, Emergency Stop Button
Operating Panel	Emergency Stop, Mode select switch (teach/playback)	
Exclusive Safety Input	External Emergency Stop, Safety Plug, External Enable Switch, Protective Stop	
Network	Ethernet	
Memory Device	USB Port	
External Dimension	369mm(W)×490mm(D)×173mm(H)	
Weight	Approx. 17kg	
Primary Power Supply	3-Phase AC200-230V ±10% Single Phase AC200-230V ±10%	
Consuming Power	0.4KVA	
Dust Proof, Drip Proof	IP20	
Ambient Temperature	0~40°C	
Ambient Humidity	20~85%(Non-condensing)	

### Controller dimensions

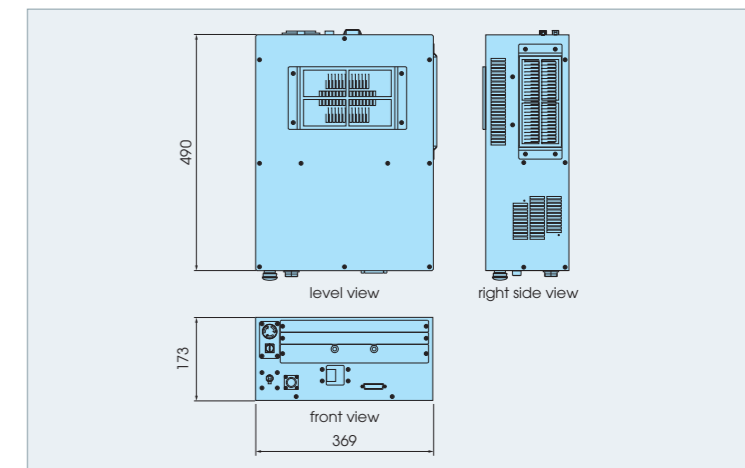

### Controller options

Item	Specification
Additional Axis	One additional axis is possible (Motor Capacity: up to 600W)
Fieldbus	DeviceNet, EtherNet/IP, PROFIBUS, PROFINET, CC-Link
Digital I/O	Up to 2pcs of 32point/32point I/O Board 8 photo coupler input and 8 transistor output or 8 photo coupler input and 8 relay contact output
External Memory	USB Memory
Vision Sensor (*)	NV-Pro
Robot Monitoring Unit (*)	Category 4, SIL 3
Controller Protection Box	IP54 equivalent Dust-proof and drip-proof box

(\*) Another box is necessary.

### Wiring and tubing inside arm (Standard)

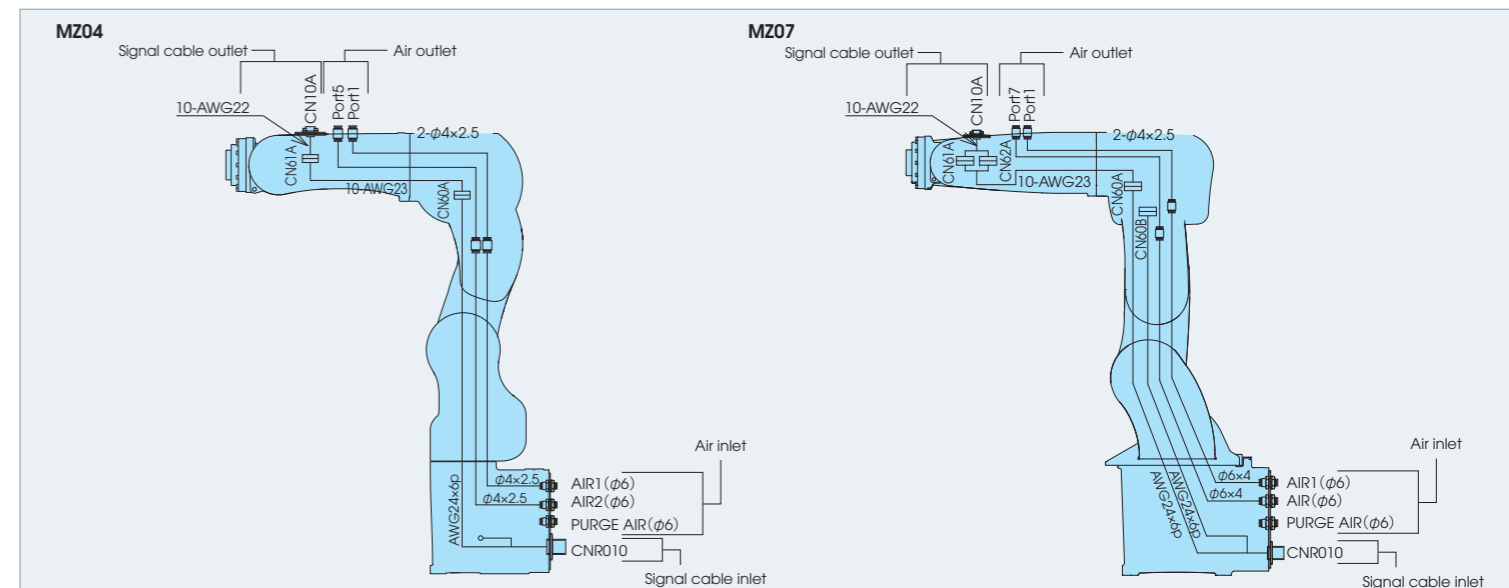

# Options

Red mark: selectable essential option

Blue mark: Option

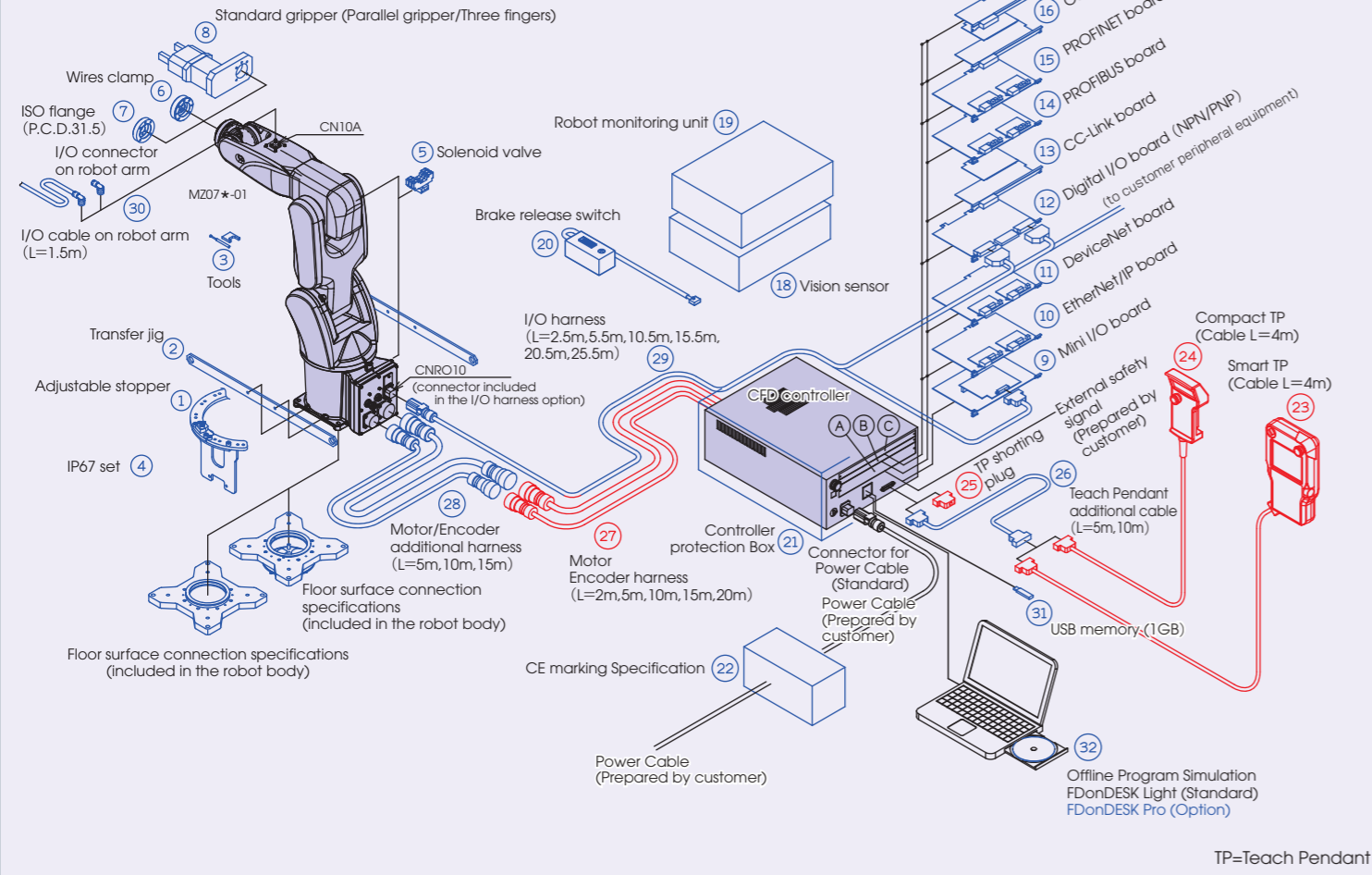

TP=Teach Pendant

## Option List

No.	Item	Specifications	Parts No.		Notes
			MZ04	MZ07	
1	Adjustable stopper	Restriction of axis 1 to 3 working envelope	OP-S5-026	OP-S5-022	
2	Transfer jig	Common for crane transporting, inverted and wall mount	OP-S2-044	OP-S2-042	
3	Tools	Zeroing pin & Zeroing block	OP-T2-089	OP-T2-078	
4	IP67 set	Air purge unit in robot body	OP-H9-008	OP-H9-004	
5	Solenoid valve	1 valve	OP-H4-006	OP-H4-004	2 position double Pressure range : 0.1 to 0.5 MPa Coil voltage rating 24 VDC
		2 valves	OP-H5-010	OP-H5-008	
		3 valves	-	OP-H6-004	
6	Wires clamp	Clamp for wires and air tubes inside wrist hollow	OP-W3-016	OP-W3-012	MZ04: Air (φ4, 5 lines), signal lines
7	ISO flange	ISO flange adapter (P.C.D.31.5)	OP-W2-013	OP-W2-012	MZ07: Air (φ4, 7 lines), signal lines
8	Standard gripper *1	Parallel gripper single S	OP-F10-009	OP-F10-002	Grip force 320N (air source 0.5MPa) Stroke 24mm
		Parallel gripper double S	-	OP-F10-003	
		Parallel gripper single M	OP-F10-010	OP-F10-004	Grip force 600N (air source 0.5MPa) Stroke 30mm
		Three fingers single S	OP-F10-011	OP-F10-005	
		Three fingers double S	-	OP-F10-006	Grip force 300N (air source 0.5MPa) Stroke 8mm
		Three fingers single M	OP-F10-012	OP-F10-007	
		Three fingers double M	-	OP-F10-008	
9	Mini I/O board	I/O Photo coupler 8 inputs / NPN Transistor 8 outputs	CFD-OP150-A		Mounted on sequence board of slot A
		I/O Photo coupler 8 inputs / Relay contact 8 outputs	CFD-OP150-B		
10	EtherNet/IP board	Master 1CH	CFD-OP130-A		Occupies (1) slot
		Slave 1CH	CFD-OP130-B		
		Master 1CH + Slave 1CH	CFD-OP130-C		
		Slave 2CH	CFD-OP130-D		
11	DeviceNet board	Master 1CH	CFD-OP131-A		Occupies (1) slot
		Slave 1CH	CFD-OP131-B		
		Master 1CH + Slave 1CH	CFD-OP131-C		
		Slave 2CH	CFD-OP131-D		
12	Digital I/O board	I/O Photo coupler 32 inputs / NPN Transistor 32 outputs	CFD-OP125-A		Occupies (1) slot
		I/O Photo coupler 64 inputs / NPN Transistor 64 outputs	CFD-OP125-B		
		I/O Photo coupler 32 inputs / PNP Transistor 32 outputs	CFD-OP151-A		
		I/O Photo coupler 64 inputs / PNP Transistor 64 outputs	CFD-OP151-B		
13	CC-Link board	Both master and slave 1CH	CFD-OP98-B		Occupies (1) slot
14	PROFIBUS board	Master 1CH	CFD-OP132-A		Occupies (1) slot
		Slave 1CH	CFD-OP132-B		
		Master 1CH + Slave 1CH	CFD-OP132-C		
		Slave 2CH	CFD-OP132-D		
15	PROFINET board	Slave 1CH	CFD-OP136-B		Occupies (1) slot
		Slave 2CH	CFD-OP136-D		
16	Conveyor Tracking I/F	RS422 Differential input encoder counter	CFD-OP47-A		Occupies (1) slot
17	Force sensor I/F	Force sensor unit for CFD (another box)	CFD-OP152-A		Occupies (1) slot
18	Vision sensor	Vision sensor unit for CFD (another box)	CFD-OP139-A		Cameras, lighting, and cables are available. Contact us for information.
19	Robot monitoring unit	Robot monitoring unit for CFD (another box)	CFD-OP145-A		
20	Brake release switch	Brake release switch (portable type)	FD11-OP90-E		
21	Controller protection BOX	Upgraded to IP54 equivalent by preparing dust-proof and drip-proof box	CFD-OP133-A		W540x700xH270
22	UL specification	Some parts are replaced to conform to UL standard	CFD-UL-A		
		CE marking compliant, separate unit	CFD-CE-A		
23	Smart TP *2	Some parts are replaced to conform to Korean KCs standard	CFD-KCS-A		
23	Smart TP *2	Cable length 4m	CFDTP-10-04M		These are selectable options. One of them must be selected.
24	Compact TP *2	Cable length 4m	MINITP-10-04M		
25	TP shorting plug *2	To disconnect teach pendant	CFD-OP153-A		
26	Teach Pendant additional cable	5m	CFDTP-RC05M		Only one cable can be added Both ends have a connector
		10m	CFDTP-RC10M		
27	Motor/Encoder harness	2m	Z101C-J1-02-A		Connects robot to controller One of these options must be selected. Select one of them.
		5m	Z101C-J1-05-A		
		10m	Z101C-J1-10-A		
		15m	Z101C-J1-15-A		
		20m	Z101C-J1-20-A		
28	Motor/encoder additional harness (Flexible type extension harness)	5m	Z102C-00-05-A, (Z102C-01-05-A)		One extension, 25 m maximum Both ends have a connector Select one of the following models if a flexible type cable is required Z102C-01-**-A (** indicates length, 05 is 5 m, 10 is 10 m, and 15 is 15 m)
		10m	Z102C-00-10-A, (Z102C-01-10-A)		
		15m	Z102C-00-15-A, (Z102C-01-15-A)		
29	I/O harness (I/O harness for connecting to Mini I/O board)	2.5m	IOCABLE-10-02M, (IOCABLE-40-02M)		I/O cable between robot and controller. IOCABLE-10-**-M type Controller side is separate cable, so cable manufacturing and signal assignment must be done by customer. IOCABLE-40-**-M type Connector on both ends to directly connect CFD-OP150-A or B (Mini I/O board) of CFD controller.
		5.5m	IOCABLE-10-05M, (IOCABLE-40-05M)		
		10.5m	IOCABLE-10-10M, (IOCABLE-40-10M)		
		15.5m	IOCABLE-10-15M, (IOCABLE-40-15M)		
		20.5m	IOCABLE-10-20M, (IOCABLE-40-20M)		
30	I/O cable on robot arm	1.5m	IOCABLE-20-01M		Tool side is separate cable. Manufacturing needs to be done by customer.
30	I/O connector on robot arm	Connector only	IOCABLE-20-00		This is connector only. Manufacturing needs to be done by customer.
		Soldering type			
31	USB memory	1GByte	FD11-OP93-A		
32	FDonDESK Pro	Robot Program Simulator	FDonDESK Pro		Following utilities are added on "FDonDESK Light" ● Program creation utility from CAD data ● Muklri robot control

## Wiring and tubing in Robot arm (when SOL installed in arm)

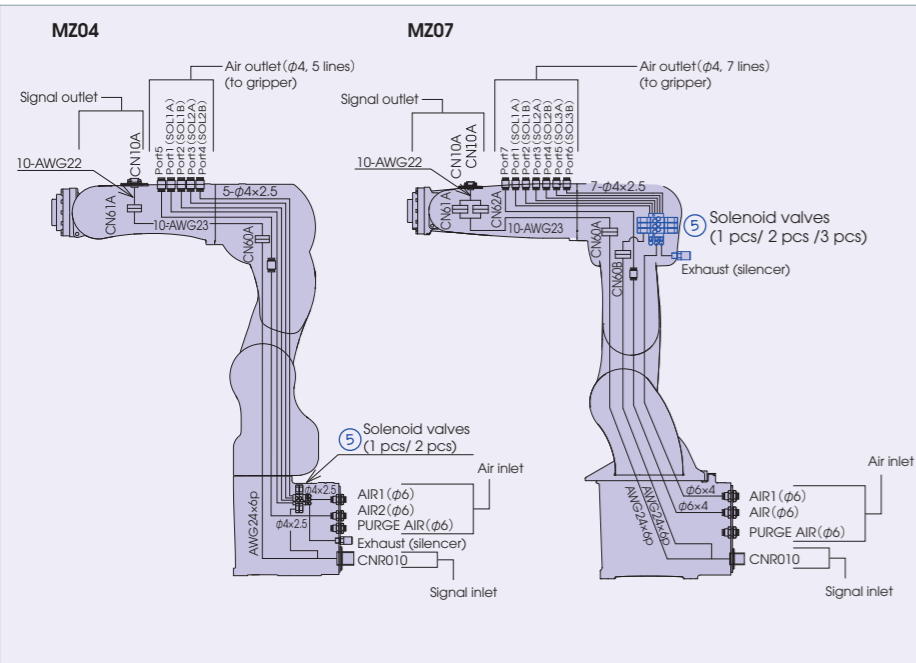

## Wrist dimensions

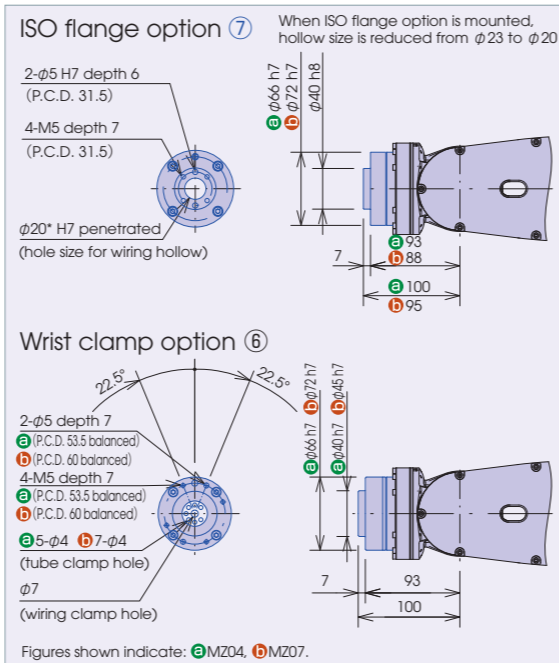

\*1 Grip force may vary according to the supplied air pressure (0.3 to 0.5 MPa) and finger length. \*2 "TP" means teach pendant.

● All option is shipped with robot by kit (sub assembly). Please install it by customer after reading option install procedure.