

IS : 783 - 1985

Indian Standard

CODE OF PRACTICE FOR
LAYING OF CONCRETE PIPES

(*First Revision*)

First Reprint AUGUST 1994

UDC 621.643.25 | 628.247.13 : 006.76

© Copyright 1986

BUREAU OF INDIAN STANDARDS
MANAK BHAVAN, 9 BARADUR SHAH ZAFAR MARG
NEW DELHI 110002

Indian Standard

CODE OF PRACTICE FOR LAYING OF CONCRETE PIPES

(*First Revision*)

Cement and Concrete Sectional Committee, BDC 2

Chairman

DR H. C. VISVESVARAYA

Representing

National Council for Cement and Building
Materials, New Delhi

Members

ADDITIONAL DIRECTOR STANDARDS (B & S)	Research, Designs and Standards Organization, (Ministry of Railways), Lucknow
DEPUTY DIRECTOR STANDARDS (B & S) (<i>Alternate</i>)	
SHRI K. P. BANERJEE	Larsen and Toubro Limited, Bombay
SHRI HARISH N. MALANI (<i>Alternate</i>)	
SHRI S. K. BANERJEE	National Test House, Calcutta
CHIEF ENGINEER (BD)	Bhakra Beas Management Board, Nangal Township
SHRI J. C. BASUR (<i>Alternate</i>)	
CHIEF ENGINEER (DESIGNS)	Central Public Works Department, New Delhi
EXECUTIVE ENGINEER (D) III (<i>Alternate</i>)	
CHIEF ENGINEER (RESEARCH-CUM- DIRECTOR)	Irrigation and Power Research Institute, Amr sar
RESEARCH OFFICER (CONCRETE TECHNOLOGY) (<i>Alternate</i>)	
DIRECTOR	A. P. Engineering Research Laboratories, Hyderabad
JOINT DIRECTOR (<i>Alternate</i>)	
DIRECTOR	Central Soil and Materials, Research Station, New Delhi
CHIEF RESEARCH OFFICER (<i>Alternate</i>)	
DIRECTOR (C & MDD-I)	Central Water Commission, New Delhi
DEPUTY DIRECTOR (C & MDD-I) (<i>Alternate</i>)	
SHRI V. K. GHANEKAR	Structural Engineering Research Centre (CSIR), Roorkee

(*Continued on page 2*)

© *Copyright* 1986

BUREAU OF INDIAN STANDARDS

This publication is protected under the *Indian Copyright Act* (XIV of 1957) and reproduction in whole or in part by any means except with written permission of the publisher shall be deemed to be an infringement of copyright under the said Act.

(Continued from page 1)

<i>Members</i>	<i>Representing</i>
SHRI A. V. GOKAK	Cement Controller (Ministry of Industry), New Delhi
SHRI S. S. MIGLANI (<i>Alternate</i>)	
SHRI A. K. GUPTA	Hyderabad Asbestos Cement Products Limited, Ballabhgarh (Haryana)
SHRI P. J. JAGUS	The Associated Cement Companies Ltd, Bombay
DR A. K. CHATTERJEE (<i>Alternate</i>)	
SHRI N. G. JOSHI	Indian Hume Pipes Co Limited, Bombay
SHRI R. L. KAPOOR	Roads Wing (Ministry of Shipping and Transport)
SHRI N. SIVAGURU (<i>Alternate</i>)	
SHRI S. K. LAHA	The Institution of Engineers (India), Calcutta
SHRI B. T. UNWALLA (<i>Alternate</i>)	
DR A. K. MULLICK	National Council for Cement and Building Materials, New Delhi
SHRI K. K. NAMBIAR	In personal capacity ('Ramanalaya', 11 First Crescent Park Road, Gandhinagar, Adyar, Madras)
SHRI S. N. PAL	M. N. Dastur and Company Private Limited Calcutta
SHRI BIMAN DASGUPTA (<i>Alternate</i>)	
SHRI H. S. PASRICHA	Hindustan Preerab Limited, New Delhi
SHRI Y. R. PHULL	Indian Roads Congress, New Delhi; and Central Road Research Institute (CSIR), New Delhi
SHRI M. R. CHATTERJEE (<i>Alternate</i>)	Central Road Research Institute (CSIR), New Delhi
DR MOHAN RAI	Central Building Research Institute (CSIR), Roorkee
DR S. S. REHSI (<i>Alternate</i>)	
SHRI P. S. RAMACHANDRAN	The India Cements Limited, Madras
SHRI G. RAMDAS	Directorate General of Supplies and Disposals, New Delhi
DR M. RAMAIAH	Structural Engineering Research Centre (CSIR), Madras
DR A. G. MADHAVA RAO (<i>Alternate</i>)	
SHRI A. V. RAMANA	Dalmia Cement (Bharat) Limited, New Delhi
DR K. C. NARANG (<i>Alternate</i>)	
DR A. V. R. RAO	National Buildings Organization, New Delhi
SHRI J. SEN GUPTA (<i>Alternate</i>)	
SHRI R. V. CHALAPATHI RAO	Geological Survey of India, Calcutta
SHRI S. ROY (<i>Alternate</i>)	
SHRI T. N. SUBBA RAO	Gammon India Limited, Bombay
SHRI S. A. REDDI (<i>Alternate</i>)	
SHRI ARJUN RIJHSINGHANI	Cement Corporation of India, New Delhi
SHRI C. S. SHARMA (<i>Alternate</i>)	
SHRI H. S. SATYANARAYANA	Engineer-in-Chief's Branch, Army Headquarters
SHRI V. R. KOTNIS (<i>Alternate</i>)	
SECRETARY	Central Board of Irrigation and Power, New Delhi
SHRI K. R. SAXENA (<i>Alternate</i>)	
SUPERINTENDING ENGINEER (DESIGNS)	Public Works Department, Government of Tamil Nadu, Madras
EXECUTIVE ENGINEER (SMD) DIVISION (<i>Alternate</i>)	

(Continued on page 76)

Indian Standard

CODE OF PRACTICE FOR LAYING OF CONCRETE PIPES

(First Revision)

0. FOREWORD

0.1 This Indian Standard (First Revision) was adopted by the Indian Standards Institution on 31 July 1985, after the draft finalized by the Cement and Concrete Sectional Committee and been approved by the Civil Engineering Division Council.

0.2 Concrete pipes are largely used for sewers, water mains, culverts and irrigation purposes. To ensure that pipes manufactured in accordance with IS : 458-1971* and IS : 784-1978† are not subjected to loads in excess of those for which they have been designed, this standard lays down the methods for finding the loads on pipes and their supporting strength and the methods for handling, laying and jointing of pipes.

0.3 Concrete pipes have to be properly handled, bedded and back-filled, if they have to carry safely the full design loads. Even the highest quality of concrete pipes manufactured in accordance with the specifications may be destroyed by improper handling, bedding and back-filling. As various factors, such as the size of the pipe and the nature of the soil influence pipe laying practice, it is not possible to lay down any rigid rules. Each case will have to be dealt with on its own merits, and this standard is intended to provide a general guidance in such work.

0.4 This standard was first published in 1959. The first revision incorporates the modifications required as a result of experience gained with the use of this standard and brings the standard in line with the present practice followed in the country.

0.4.1 In the present revision a number of important basic modifications with respect to symbols, illustrative figures, graphs, impact factors, testing, etc, have been introduced. Examples of calculations of loads on pipes

*Specification for concrete pipes (with and without reinforcement) (*second revision*).

†Specification for prestressed concrete pipes (including fittings) (*first revision*).

under different installations conditions have also been incorporated in this revision.

0.5 In the preparation of this standard assistance has been derived from AS CA33-1962 'Concrete pipe laying design' issued by the Standards Association of Australia.

0.6 For the purpose of deciding whether a particular requirement of this standard is complied with, the final value, observed or calculated, expressing the result of a test or analysis, shall be rounded off in accordance with IS : 2-1960.* The number of significant places retained in the rounded off value should be the same as that of the specified value in this standard.

1. SCOPE

1.1 This standard covers recommended design practice for the laying of precast concrete pipes. It includes methods for calculating loads on pipes according to installation conditions, and gives the corresponding load factors.

1.1.1 This standard is intended primarily for use in association with IS : 458-1971† and IS : 784-1978‡ for pipes, but may also be used for the calculation of loads on other rigid pipes.

2. APPLICATION

2.1 The purpose of this standard is to provide a basis for relating the loads on precast concrete pipes laid under various installation conditions to the test strength of pipe in accordance with IS : 458-1971† through load factors appropriate to the installation conditions.

The provisions of this standard may be used:

- a) to calculate external loads which, when divided by the appropriate load factor, will indicate the strength of pipe required in terms of the test loads given in IS : 458-1971†; and
- b) to assess the supporting strength of a pipe under specified installation conditions by multiplying the test load given in IS : 458-1971† for the class of pipe by the load factor specified herein, and hence to determine the permissible loading conditions.

*Rules for rounding off numerical values (*revised*).

†Specification for concrete pipes (with and without reinforcement) (*second revision*).

‡Specification for prestressed concrete pipes (including fittings) (*first revision*).

3. TERMINOLOGY

3.0 For the purpose of this standard, the following definitions shall apply.

3.1 Pipe — A single length of pipe.

3.2 Superimposed Load — A load, concentrated or distributed, static or dynamic, applied at the surface of the fill material.

3.3 Test Load — The load which a precast concrete pipe is required to sustain when tested by the method given in IS : 458-1971*

NOTE — For an unreinforced pipe the test load is sustained without cracking. For a reinforced pipe the test load is sustained without developing a clearly visible crack as defined in IS : 3597-1985†.

3.4 Load Factor — A factor used in the calculation of the required test load for a pipe. The factor varies with the type of load and with the installation conditions (see 10) .

3.5 Earth — All material other than rock.

3.6 Rock — An unyielding natural foundation material; includes gneous material and consolidated or cemented sedimentary mineral matter in extensive undisturbed beds or strata.

4. SYMBOLS

4.1 For the purpose of this standard, the following letter symbols shall have the meaning indicated against each:

B = width of trench in metres measured at the level of top of the pipe.

C_e = a coefficient used in the calculation of the vertical load on a pipe due to the weight of fill material when the pipe is installed under positive projection embankment conditions (see Fig. 1).

C_n = a coefficient used in the calculation of the vertical load on a pipe due to the weight of fill material (see Fig. 2) when the pipe is installed under:

- a) negative projection conditions, and
- b) imperfect trench condition.

C_p = a coefficient used in the calculation of the vertical load on a pipe due to concentrated superimposed loads (see Fig. 3) when the pipe is installed under :

*Specification for concrete pipes (with and without reinforcement) (second revision).

†Methods of test for concrete pipes (first revision).

- a) trench conditions, and
- b) embankment conditions.

C_t = a coefficient used in the calculation of the vertical load on a pipe due to the weight of fill material when the pipe is installed under trench conditions (see Fig. 4).

C_u = a coefficient used in the calculation of the load on a pipe due to a uniformly distributed superimposed load of U kN/m² (see Fig. 5).

d = internal diameter of a pipe in m.

D = external diameter of a pipe in m.

F_e = load factor for a pipe installed under positive projection embankment conditions and subjected to load from earth fill material only.

F_p = load factor for a pipe subjected to a concentrated load.

F_t = load factor for a pipe installed under trench conditions or negative projection embankment conditions and subjected to load from earth fill material only.

h = vertical distance, in metre, from the level of the top of a pipe down to the undisturbed foundation level, or trench bottom, adjacent to the pipe (see Appendix A).

h' = vertical distance, in metre, from the level of the top of a pipe up to the natural ground level, where the pipe is installed under negative projection conditions (see Appendix A) or depth of trench in metre excavated in consolidated fill material and refilled with loose fill material, where a pipe is installed under imperfect trench conditions (see Appendix A).

H = vertical distance in metres measured from the level of the top of a pipe to the surface of the fill material over the pipe (see Appendix A).

K = ratio of the active horizontal pressure at a point in fill material to the vertical pressure which causes this horizontal pressure, given by:

$$K = \frac{1 - \sin \phi}{1 + \sin \phi} = \tan^2 \left(\frac{\pi}{4} - \frac{\phi}{2} \right) = \frac{\sqrt{\mu^2 + 1} - \mu}{\sqrt{\mu^2 + 1} + \mu}$$

(Rankine's formula)

l = length of a pipe in metre over which a vertical concentrated load is assumed to be distributed (see 9).

P = concentrated load in kN.

p = projection ratio of a pipe installed under embankment conditions. It is calculated by dividing the vertical distance h from the top of the pipe down to the level of the undisturbed ground surface at the sides of the pipes, by the external diameter D of

the pipe, that is $\frac{h}{D}$ (see A-2 and A-3),

NOTE 1 — Where a pipe is laid on a continuous concrete cradle the top horizontal surface of the cradle (see B-9 and B-10) may be taken as the level of the undisturbed ground surface.

NOTE 2 — Where a pipe is laid in a wide trench with no bench of undisturbed ground at the sides of the pipe, the top horizontal surface of compacted sand or other granular foundation material at the sides of the pipe may be taken as the level of the undisturbed ground surface provided the foundation material at the sides of the pipe is compacted to the same density as the undisturbed ground or to 90 percent of the maximum density at optimum moisture content as determined by a suitable method.

NOTE 3 — Where the site is irregular it is usual to average the levels at distance D on each side of the centre line of the pipe, but the level from which the average is calculated should never be taken more than $1.5 D$ from the centre line.

P' = negative projection ratio of a pipe, defined as the ratio of the depth of the fill material measured from the top of the pipe to the natural ground surface to the width of the trench, that is:

$\frac{h'}{B}$ (see A-4 and A-5)

NOTE 1 — For imperfect trench conditions, p' is defined as the ratio of the depth of the trench excavated in the compacted fill material to the width of the trench which preferably should be equal to the external diameter of the pipe (see A-4).

NOTE 2 — Where the site is irregular it is usual to average the levels at distance D on each side of the centre line of the pipe, but the level from which the average is calculated should never be taken more than $1.5 D$ from the centre line.

r_s = settlement ratio of a pipe (see Appendix B).

For negative projection conditions the definition differs from that for positive projection conditions.

S = length of a concentrated load along a pipe in metre.

t = wall thickness of a pipe in mm.

U = uniformly distributed static load superimposed on the fill material over a pipe in kN/m^2 .

w = unit weight of fill material in kN/m^3 .

NOTE — Unit weights of materials vary between 14.4 kN/m^3 for loose granular material, and 20 kN/m^3 for densely compacted clay and gravel. Where the actual unit weight is not known, a value of 18 kN/m^3 be assumed for most soils not specially compacted.

W_c = calculated vertical external load on a pipe due to superimposed concentrated load, including any allowance for impact in kN/m .

W_o = calculated vertical external load on a pipe due to fill material, including superimposed distributed load treated as fill material in kN/m .

W_t = required test load for a concrete pipe, in kN/m .

W_u = calculated vertical external load on a pipe due to superimposed uniformly distributed load in kN/m .

X = proportion of the vertical height of a pipe embraced by the bedding material.

α = *Impact Factor* — a factor by which a live load is multiplied in order to make allowance for the dynamic effect of impact.

μ = coefficient of internal friction of the fill material equal to $\tan \phi$.

μ' = coefficient of friction between the fill material and the sides of a trench in undisturbed material.

ϕ = angle of internal friction for earth.

5. TEST LOAD

5.1 The required minimum test load for a pipe is calculated as follows:

- a) *Reinforced Pipe* — Divide each is of the calculated vertical loads (see 7, 8 and 9) by the load factor appropriate to the type of loading and installation conditions (see 10) and add the quotients.
- b) *Unreinforced Pipe* — Multiply the sum of the quotients determined in accordance with (a) by 1.5.

The class of pipe required is then chosen from IS : 458-1971*, unless a specially designed pipe is required.

*Specification for concrete pipes (with and without reinforcement) (*second revision*).

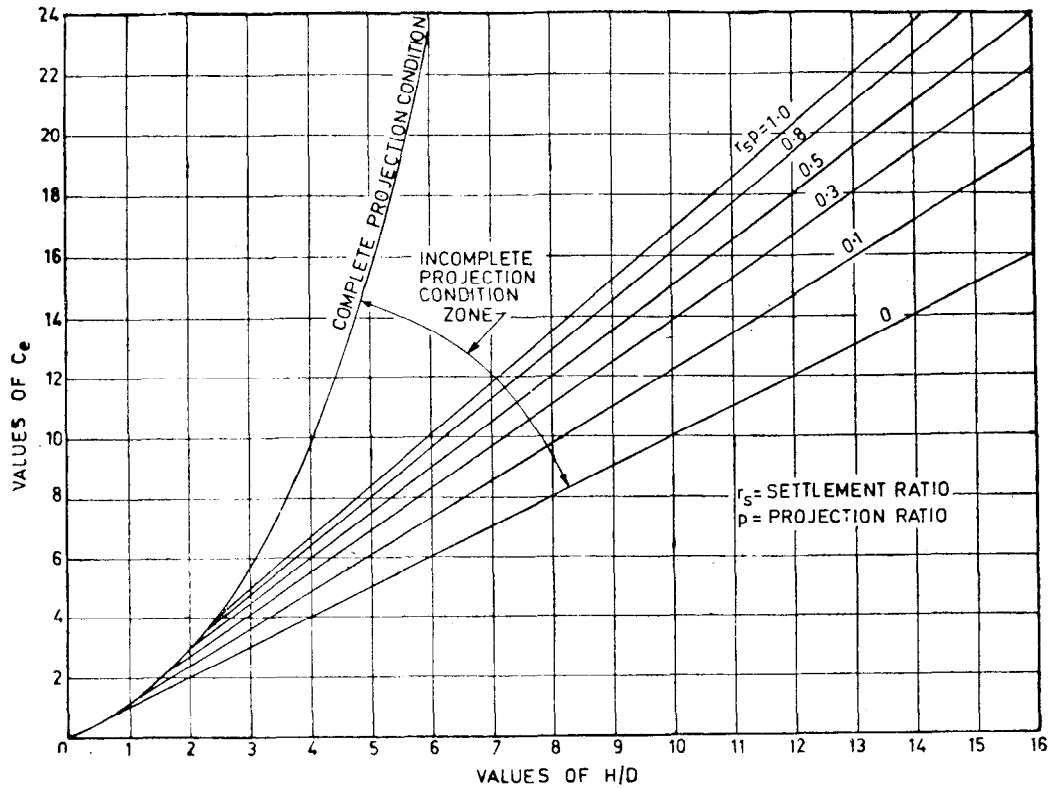

NOTE — The curves are drawn for a value of $K\mu = 0.1924$ which is applicable to granular soils with cohesion. The value is slightly conservative for other materials.

FIG. 1. VALUES OF COEFFICIENT C_e IN FORMULA $W_e = C_e w D^3$ (APPLICABLE TO EMBANKMENT CONDITIONS WITH POSITIVE PROJECTION)

As in the Original Standard, this Page is Intentionally Left Blank

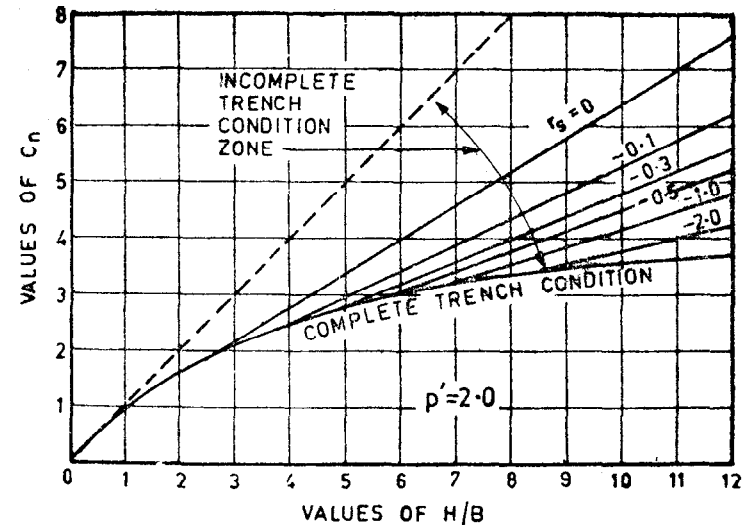
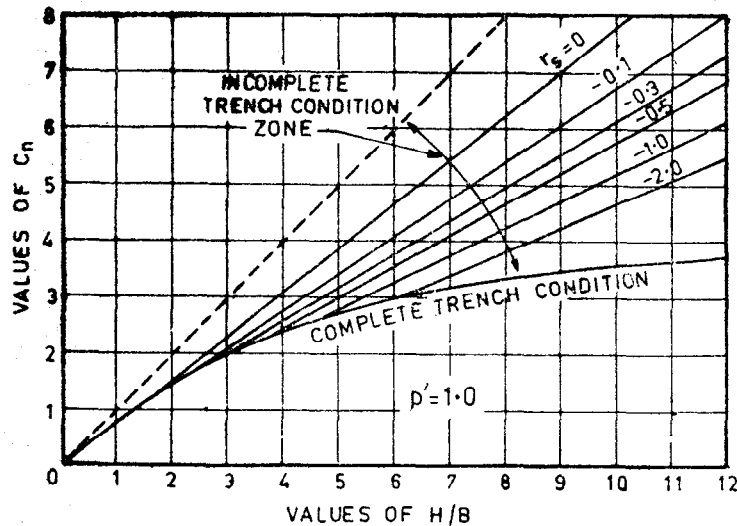
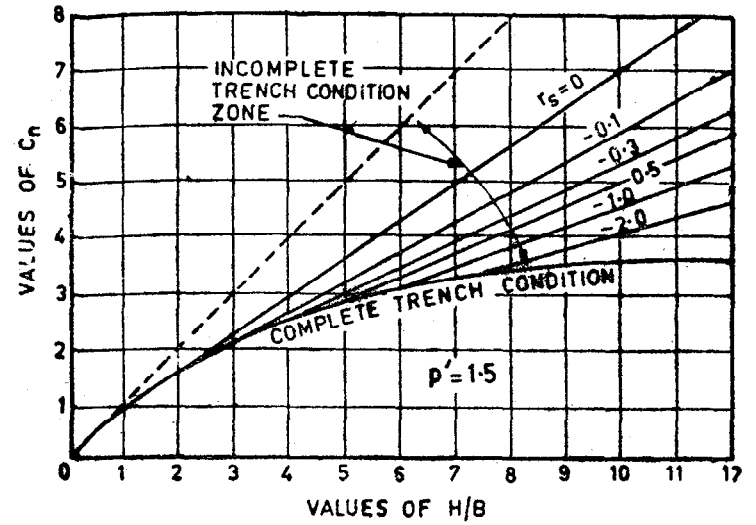
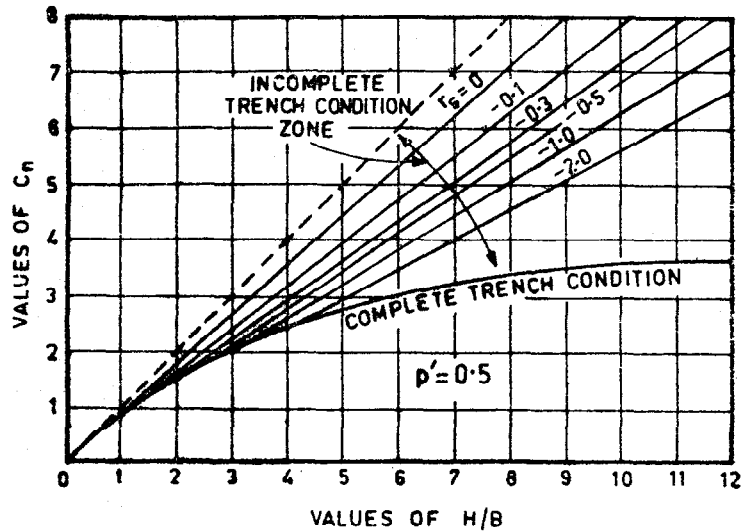

NOTE — The curves are drawn for $K\mu = 0.13$, that is normal wet clay.

FIG. 2 VALUES OF COEFFICIENT C_n IN FORMULA $W_e = C_n w B^3$ (APPLICABLE TO EMBANKMENT CONDITIONS WITH NEGATIVE PROJECTION)

As in the Original Standard, this Page is Intentionally Left Blank

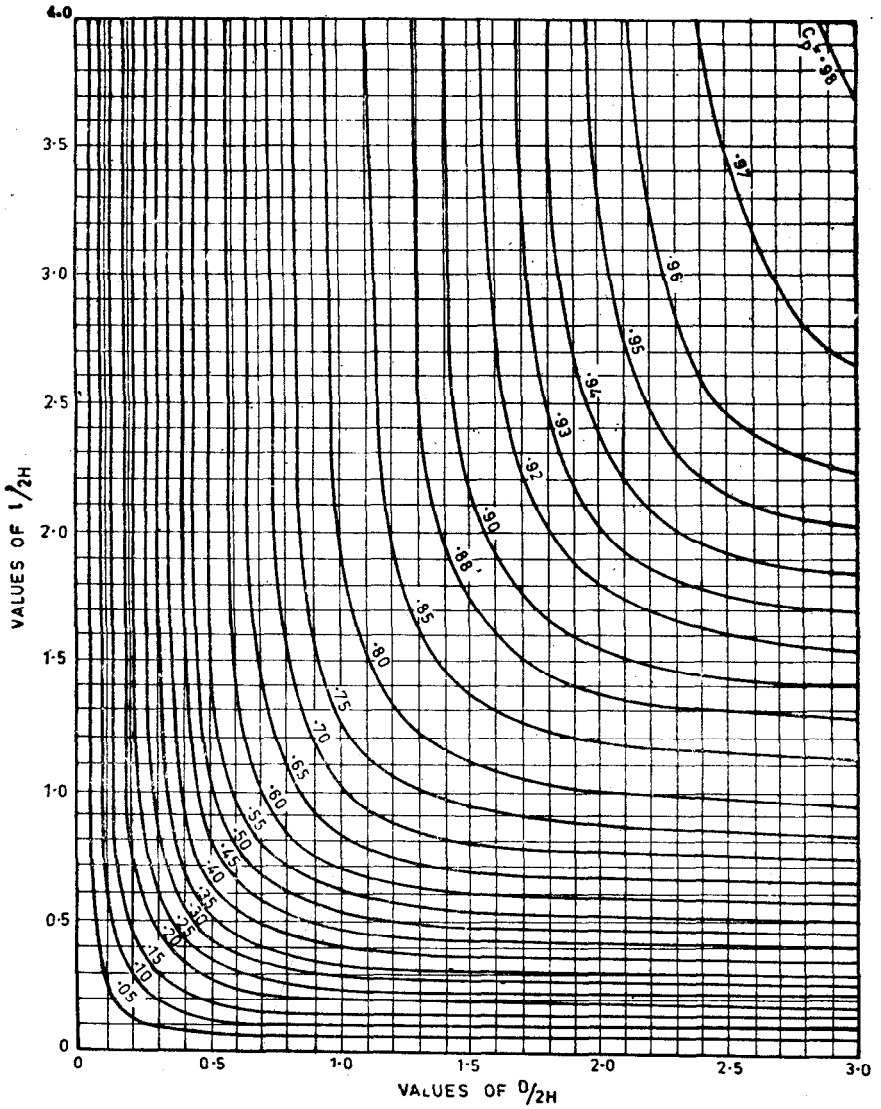

FIG. 3 VALUES OF COEFFICIENT C_p IN FORMULA $W_c = C_p \frac{P \alpha}{l}$

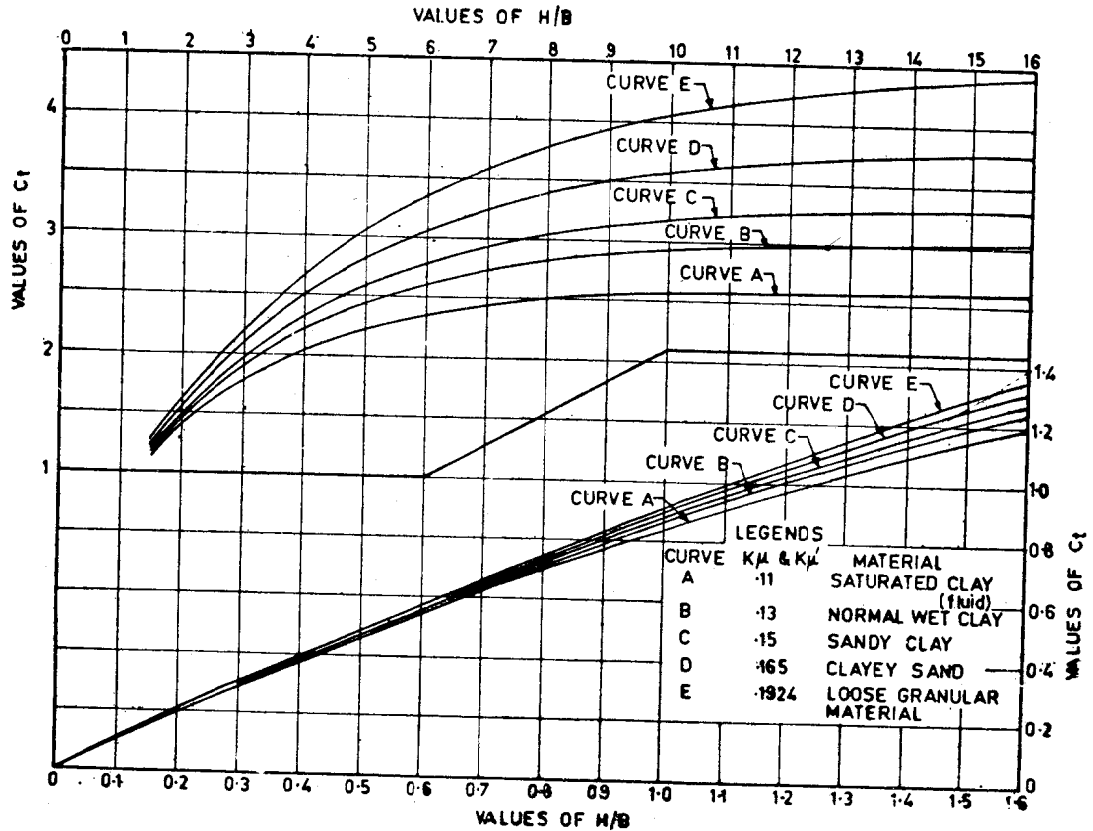

FIG. 4 VALUES OF COEFFICIENT C_t IN FORMULA $W_t = C_t w B^2$

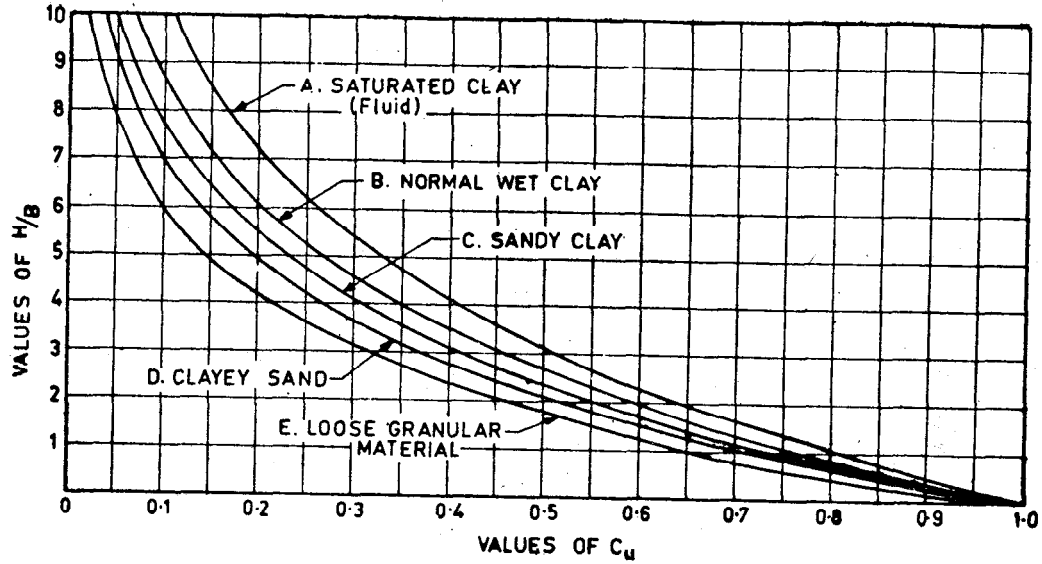

FIG. 5 VALUES OF COEFFICIENT C_u IN FORMULA $W_u = C_u BU$

6. VERTICAL LOADS ON PIPES—GENERAL

6.1 Types of Loading — In the design of a concrete pipe an assessment shall be made of the following vertical loads:

- a) The static load at the level of the top of the pipe due to the fill material,
- b) The static load at the level of the top of the pipe due to loads superimposed on the fill material, and
- c) The internal static load due to the weight of water contained in the pipe.

6.2 Data Required — In order to make an assessment of the vertical loads the following data shall be available or assumed:

- a) The height H of the fill material above the top of the pipe;
- b) The maximum unit weight w of the fill material;
- c) The magnitude of any loads superimposed on the fill material and the nature of the loads, that is whether the loads are distributed or concentrated, static or dynamic;
- d) The pipe installation conditions (*see* Appendix B);
- e) The projection ratio, if the pipe is installed under embankment conditions or negative projection conditions;
- f) The width of trench, if the pipe is installed under trench conditions;
- g) The external diameter D of the pipe;
- h) The internal diameter d of the pipe;
- j) The coefficient of internal friction μ of the fill material;
- k) The coefficient of friction μ' between the fill material and the sides of the trench (usually assumed to be equal to $\tan \phi$); and
- m) The settlement ratio r_s .

7. VERTICAL LOAD ON A PIPE DUE TO FILL MATERIAL

7.1 The vertical load on a pipe due to fill material shall be calculated from the formula given in A-1 to A-5 appropriate to the pipe installation conditions.

8. VERTICAL LOAD ON A PIPE DUE TO SUPERIMPOSED STATIC UNIFORMLY DISTRIBUTED LOAD

8.1 Trench Conditions — For a pipe installed under trench conditions the vertical load due to a uniformly distributed superimposed static load shall be calculated from the following formula:

$$W_u = C_u BU$$

where C_u has the values given in Fig. 5.

8.2 Embankment Conditions — For a pipe installed under embankment conditions the vertical load due to a uniformly distributed static superimposed load shall be calculated as follows:

- a) Calculate the height of fill material equivalent to the load per unit area of the superimposed distributed load, that is, equivalent height of fill material

$$= \frac{\text{Superimposed load (kN/m}^2\text{)}}{\text{Unit weight of fill material (kN/m}^3\text{)}}$$

- b) Add the height so calculated to the actual height of the embankment above the top of the pipe to obtain the height H ;
- c) Determine the coefficient C_e or C_n , as appropriate, from Fig. 1 and 2; and
- d) Calculate the load on the pipe using the appropriate formula given in Appendix A.

9. VERTICAL LOAD ON A PIPE DUE TO SUPERIMPOSED CONCENTRATED LOAD

9.1 The vertical load on a pipe due to a superimposed concentrated load P shall be calculated from the following formula:

$$W_c = C_p \frac{P\alpha}{l}$$

where

C_p has the value given in Fig. 3 appropriate to the ratios

$$\frac{l}{2H} \text{ and } \frac{D}{2H}$$

α = has the value given in 11 if the load is dynamic, and a value of unity if the load is static; and

l = is the length of the pipe assumed to be carrying the concentrated load. It may be calculated from the following formula but should not exceed the length of the pipe:

$$l = 1.15 H + 2D + S$$

Where at least 300 mm of consolidated earth or equivalent cover cannot be provided, the wheel loads shall be assumed to be applied directly to the pipe.

10. LOAD FACTORS

10.1 Load Due to Fill Material or Uniformly Distributed Load — The load factors applicable when pipes are loaded with fill material and/or a uniformly distributed static superimposed load, and are installed under various conditions are given in Appendix B.

10.2 Concentrated Loads — The load factor applicable when pipes are loaded with concentrated superimposed static or live loads shall be 1.5 irrespective of the pipe installation conditions, except that for Class *D* bedding, the factor shall be 1.1.

NOTE — The load factors given in B-9 to B-16 are applicable for loose granular fill material. For other fill material, the load factors given will be conservative.

11. IMPACT FACTORS

11.1 Effect of Impact — Where superimposed loads are dynamic, allowance shall be made for the effect of impact by multiplying the superimposed load by an impact factor α appropriate to the type of loading, the depth of cover over the pipe, and the smoothness of any load bearing surface over the pipe, as indicated in 11.2, 11.3 and 11.4. When considering the effect of impact, the depth of cover over the top of the pipe is critical.

11.2 Road Vehicle Loading — The impact factor α depends on the depth of cover measured from the top of the pipe to the top of the pavement above the pipe, and on the smoothness of the pavement surface.

The impact factors given in Table 1 shall be used where a smooth pavement surface is anticipated. Where a rough pavement surface is anticipated (that is, due to settlement of the fill material), and the depth of cover is 900 mm or less, the impact factors shall be increased by at least 20 percent.

11.3 Aircraft Loading — An impact factor α of unity shall be used for all depths of cover and all pavement surface conditions.

11.4 Railway Loading — The impact factor α depends on the depth of cover over the pipe, measured from the top of the pipe to the underside of the rails. The impact factors given in Table 2 shall be used.

TABLE 1 IMPACT FACTORS FOR ROAD VEHICLE LOADING
(Clause 11.2)

DEPTH OF COVER	IMPACT FACTOR α FOR SMOOTH PAVEMENT SURFACE
0	1.3
300 mm	1.2
600 mm	1.1
900 mm	1.0

NOTE — For intermediate depth of cover, linear interpolation shall be made.

TABLE 2 IMPACT FACTORS FOR RAILWAY LOADING
(Clause 11.4)

DEPTH OF COVER	IMPACT FACTOR α
600 mm	1.7
900 mm	1.5
3.0 m and above	1.0

NOTE — For intermediate depth of cover, linear interpolation shall be made.

12. INTERNAL WATER LOAD

12.1 The vertical load due to water carried in a pipe need only be taken into account where the pipe is laid on Type D bedding (see B-7, B-8, B-15 and B-16).

Where it is necessary to take the water load into account the pipe should be assumed full, and three-quarters of the weight of the water per linear metre of the pipe should then be added to the vertical loads calculated in accordance with 7, 8 and 9.

13. SUPPORTING STRENGTH OF A PIPE SUBJECTED SIMULTANEOUSLY TO INTERNAL PRESSURE AND EXTERNAL LOAD

13.1 Simultaneous action of internal and external load gives a lower supporting strength of a pipe than what it would be if the external load acted alone.

If the maximum internal pressure and three edge bearing strength for a pipe are known, the relation (see Fig. 6) between the internal pressure and external load is given by:

$$T = \frac{W}{F} \left(\frac{P_t}{P_t - P_w} \right)^{1/3}$$

where

W = site external working load in kN/m of pipe,

F = load factor,

T = external three edge bearing load per metre pipe,

P_t = hydrostatic test pressure at factory in MPa,

P_w = working pressure on the line in MPa, and

$\frac{W}{F}$ = test load equivalent to the site external working load W .

It shall be noted from Fig. 6 that:

- a) for any working pressure P_w the ordinate $P_w X$ equals the maximum simultaneous three edge bearing test load W/F which can safely be applied to the pipe. By multiplying W/F by the appropriate load factor F , the value W of external vertical load from earth fill, etc, which the pipe can safely support is obtained;
- b) alternatively, if the value W/F is predetermined by the installation conditions, the intersection X of a horizontal line drawn through W/F with a vertical line through P_w should then lie below the curve; and
- c) if, for a predetermined value of W/F the intersection of X is above the curve constructed for test values proposed, a higher test load T or test pressure P_t should be chosen.

14. JOINTS FOR PIPES

14.1 Types — The joints may be mainly of two types:

- a) Rigid joints, and
- b) Flexible joints.

14.2 Rigid Joints — In this the water seal is effected by cement mortar or similar material which will not allow any movement between the two pipes.

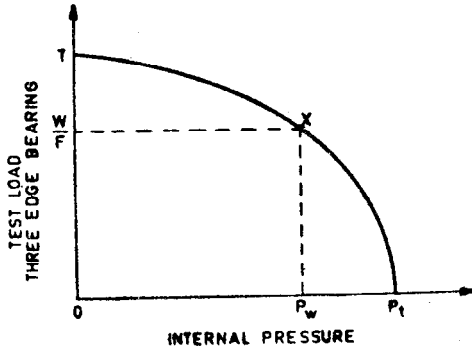

FIG. 6 COMBINATION OF INTERNAL PRESSURE AND EXTERNAL LOAD

14.2.1 Socket and Spigot Joint — The annular space between socket and spigot is filled with cement mortar (1 : 2). This joint is used for low pressure pipe line. The details of joint are shown in Fig. 7.

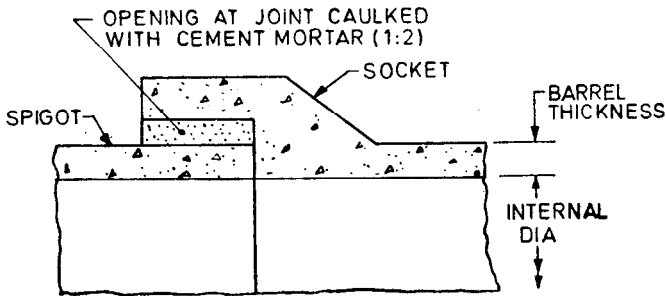

FIG. 7 SPIGOT AND SOCKET JOINT (RIGID)

14.2.2 Collar Joint — Collars of 15 to 20 cm wide cover the joint between two pipes. A slightly damp mixtures of cement and sand is rammed with caulking tool. The details are shown in Fig. 8.

14.2.3 Flush Joint

14.2.3.1 Internal flush joint — This joint is generally used for culvert pipes of 900 mm diameter and over. The ends of the pipes are specially shaped to form a self centering joint with an internal jointing space 1.3 cm wide. The finished joint is flush with both inside and outside with the

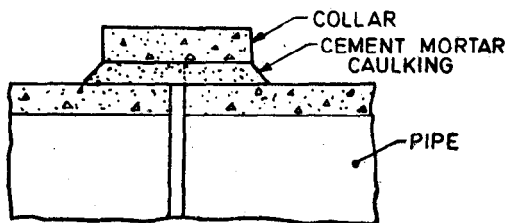

FIG. 8 COLLAR JOINT (RIGID)

pipe wall (see Fig. 9). The jointing space is filled with cement mortar mixed sufficiently dry to remain in position when forced with a trowel or rammer.

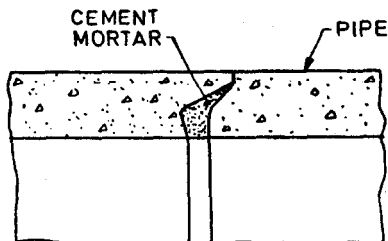

FIG. 9 INTERNAL FLUSH JOINT (RIGID)

14.2.3.2 External flush joint — This joint is suitable for pipes which are too small for jointing from inside. Great care shall be taken in handling to ensure that the projecting ends are not damaged as no repairs can be readily effected from inside the pipe. Details of the joint are shown in Fig. 10.

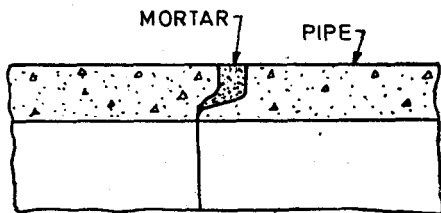

FIG. 10 EXTERNAL FLUSH JOINT (RIGID)

14.3 Flexible Joints — The water seal is effected because of contact pressure between the sealing rubber ring (or similar material) and the pipe surface. These are mainly two types.

14.3.1 Roll on Joint — A rubber ring (circular in cross-section) is placed at or near the end of the spigot and rolls along it as the spigot enters the socket. The details of the joint are shown in Fig. 11.

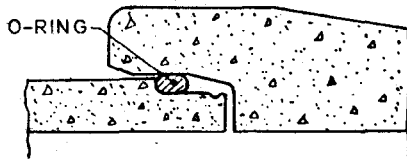

FIG. 11 ROLL ON JOINT (FLEXIBLE)

14.3.2 Confined Gasket — Rubber ring of circular cross-section is held in the groove formed on the spigot. Some times, the cross-section is in the shape of lip. The lips are opened due to water pressure which ensure water seal. For assembly of this joint a lubricant has to be applied to the sliding surfaces. The lubricant washes off when the pipe is in service. The details of the joint are shown in Fig. 12.

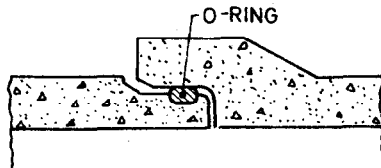

FIG. 12 CONFINED O-RING JOINT (FLEXIBLE)

15. CONSTRUCTION

15.1 Transport, Handling and Stringing

15.1.1 Transport — Pipes should be loaded at the works for transportation, either by rail or by road, in such a way that they are secure and that no movement can take place on the vehicle during transit. The same care is needed if pipes are to be transferred from one vehicle to another, however, short the journey may be.

15.1.2 Off Loading — Off loading should be carried out by means of chainblock with shear legs or crane of adequate capacity, using properly designed slings and spreader beams or specially designed lifting beams (see Fig. 13). Slings should be placed around the circumference of the pipe and should not be threaded through the pipe bore as the latter method may damage the jointing surfaces. For the same reasons, hooks located in the ends of the pipes should not be used.

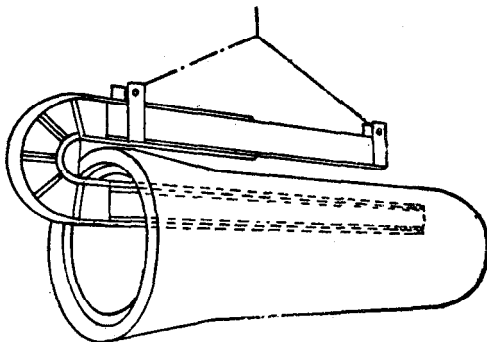

FIG. 13 A TYPICAL LIFTING BEAM

15.1.3 Stacking — Pipes may be placed directly on the ground provided it is reasonably level and free from rocks and other projections. Stacking in tiers is permissible provided timber bearers are placed between succeeding tiers. If pipes are to be stacked more than two tiers high, reference should be made to manufacturer for advice before exceeding the two tiers specified.

15.1.4 Stringing — Stringing consists of placing pipes on the ground in line ready for laying. Care is again needed to prevent damage during this operation.

15.2 Trench Excavation — Trench shall be of sufficient width to provide a free working space on each side of the pipe. The free working space shall be preferably not less than 150 mm on either side. For deeper excavations wider trench may be required. The trench width should be kept minimum, sufficient to allow proper tamping of the backfill. Any inadvertant increase in the actual width should be referred to the designer. If the sides of the trench are not vertical, the toes of the side slopes shall end at the top of pipe, and practically vertically sided trench shall be dug from these down to the subgrade.

15.3 Pipe Inspection and Repairs

15.3.1 Inspection of Pipe Before Laying — Prior to being placed in the trench, pipes should be visually inspected for evidence of damage with

particular emphasis laid on examination of the joint surfaces which may have been damaged by impact during transit or during off loading and handling at site.

15.3.2 Repairing Damaged Pipes — Any damage to the pipe may impair its strength or integrity consequently although some minor damage may be repairable at site, such repairs should be undertaken only by pipe manufacturer or under his supervision.

15.4 Laying, Jointing and Anchoring

15.4.1 Laying — Pipes should be lowered into the trench with tackle suitable for the weight of pipes, such as well designed shear slings with chain block or mobile crane. While lifting, the position of the sling should be checked when the pipe is just clear off the ground to ensure proper balance. Laying of pipes shall preferably proceed upgrade of a slope. If the pipes have rubber ring joint it is easier to force spigot into socket. In case of collar joint, the collars shall be slipped on before the next pipe is laid. Expansion joint shall be provided for buried line at maximum intervals of 100 m, but for exposed pipes, the joint intervals shall not exceed 45 m. Cast iron or steel collars and lead caulking conforming to IS : 782-1978* shall be used for expansion joint. Where flexible rubber ring joints are used, expansion joints need not be provided. When laying is not in progress, the open end of the pipe line should be fitted with temporary end-closure. This may make the pipe buoyant in the event of the trench becoming flooded and any movement of the pipes should be prevented either by partial refilling of the trench or by temporary strutting.

15.4.2 Jointing—The sections of the pipe should be jointed together in such a manner that there shall be as little unevenness as possible along the inside of the pipe. The procedure will vary according to the type of joint being used. Basic requirements for all types are:

- a) cleanliness of all parts, particularly joint surface;
- b) correct location of components;
- c) centralization of spigot within socket;
- d) provision of the correct gap between the end of the spigot and the back of the socket (for rubber ring joint) to ensure flexibility at each joint; and
- e) any lubricant used shall be approved as to composition and method of application.

*Specification for caulking lead (*third revision*).

Details of jointing shall be as recommended by the manufacturer.

For collar joint the loose collar shall be set up over the joint so as to have an even caulking space all round. Into this caulking space shall be rammed 1 : 1.5 mixture of cement and sand for pressure pipes and 1 : 2 for non-pressure pipes just sufficiently moistened to hold together in the hand. The caulking shall be so firm that it shall be difficult to drive the point of a pen into it. The caulking shall be employed at both ends in a slope of 1 : 1. In place of cement mortar, any other suitable approved compound may be used. Every caulked joint shall be kept wet for about ten days for maturing. The section of the pipe line laid and jointed shall be covered immediately to protect it from weather effects. A minimum cover of 100 mm is considered adequate. A polythene sheet also be used to cover the joints to prevent evaporation of water.

15.4.2.1 Change of direction — Small changes in direction may be made by setting adjacent pipes at a slight angle to one another. The maximum angle will vary with the type of joint used and the diameter of pipe. Maximum permissible angle shall be as recommended by the manufacturer.

15.4.3 Laying and Anchoring of Pipes on Gradients — Where gradient steeper than 1 in 6 is contemplated consideration should be given to the construction of suitable transverse anchor blocks spaced as shown in Table 3.

TABLE 3 SPACING OF TRANSVERSE ANCHORS FOR STEEPLY INCLINED PIPELINES

GRADIENT	SPACING m
1 : 2 or steeper	5
1 : 3 or 1 : 4	10
1 : 5 or 1 : 6	15
1 : 7 or 1 : 12	Depends on ground conditions.
Flatter than 1 : 12	Not usually required

For gradients between 1 in 7 and 1 in 12, the need for transverse anchor blocks will depend on ground conditions. For slopes flatter than 1 in 12, there is seldom need to provide anchor blocks.

It should be noted that where very steep gradients occur the trench may act as a drain after back filling has been completed, the flow of water

could disturb granular bedding material, hence, reducing the effective support for the pipes. In these circumstances alternative bedding material should be considered. If the flow of water through the bedding material is potentially substantial, clay water stops should be introduced.

In the case of gradients steeper than 1 in 15, consideration should be given to the use of suitable spacers to achieve the correct gap between the end of the spigot and the back of the socket. Precautions should be taken to ensure that there is no movement of adjacent pipes relative to each other, immediately after the jointing operation is complete. As soon as joint assembly is complete, the last pipe laid should be firmly restrained in position until back filling over it is complete and well compacted.

15.5 Testing

15.5.1 General — All pipelines should be tested before being brought into service. The test should be a hydrostatic test performed by filling the pipeline with water and raising the pressure to the selected test pressure and maintaining this for a sufficient period to allow for absorption of water by the pipe material. A graph of quantity of water added to maintain the test pressure against time will show when absorption of water is substantially completed. In the case of large diameter low pressure pipes consideration may be given to internal testing of joints only.

15.5.2 Site Test Pressure — The site test pressure to be imposed should have already been determined when placing orders for pipes and fittings. In general, this pressure should not be less than the maximum pipeline operating pressure plus the calculated surge pressure allowance, but in no case, should it exceed the works hydrostatic proof test pressure. If pressure measurements are not made at the lowest point of the section under test, an allowance should be made for the static head between the lowest point and the point of measurement to ensure that the maximum pressure is not exceeded at the lowest point.

15.5.3 Test Procedure — At the commencement of a pipe laying project, it is prudent to test comparatively short section in order to establish the test procedure and gain experience; thereafter, the test may be applied to longer lengths.

Each section should be properly sealed off, preferably with special stop ends secured by adequate anchors. The thrust on the stop ends should be calculated on the full socket internal diameter and the anchors designed to resist it. It may often be economical to provide a concrete anchor block of couple of pipes laid and earth tamped around which has subsequently to be demolished rather than risk movement of the stop ends during testing. Hydraulic jacks may be inserted between the temporary anchors and stop

ends in order to take up any horizontal movement of the temporary anchor. All permanent anchors should be in position and, if of concrete, should have developed adequate strength before testing begins. The section under test should be filled with water, taking care that all air is displaced either through vents at the high points, or by using a swab.

After filling, the pipeline should be left under operating pressure for a period in order to achieve conditions as stable as possible for testing. The length of this period will depend upon many factors such as initial permeability, absorption, movement of the pipeline under pressure and the quantity of air trapped. More water should be pumped in from a calibrated container until the required test pressure is reached. The test pressure should be maintained throughout the test by means of continuous pumping, using a pressure relief valve. The excess water coming from the relief valve should be returned to the calibrated container. The rate of loss of water from the container should be determined at regular intervals; the standard of acceptance should be clearly specified and the test should be continued until this is achieved. The generally accepted standard for non-absorbent pipelines such as steel and iron is 0.1 litre per millimetre of pipe diameter per kilometre of pipeline per day for each 30 metre head of pressure applied. Concrete is an absorbent and permeable material, the factors which govern the absorption and permeability are very complex and they cannot at the present time be subject to accurate analysis. It is known, however, the following factors play an important part:

- a) The density of the concrete,
- b) The amount of surplus (non-combined) water present in the concrete at the commencement of the test,
- c) The amount and quality of the cement matrix (water-cement ratio and cement content of mix),
- d) The thickness of the concrete unit under test,
- e) The pressure applied, and
- f) The duration of the test.

Laboratory permeability tests are usually conducted under very low heads, (about 0.1 atmosphere) which is in the order of 1 percent of the operating pressure of many trunk water mains. For low head laboratory permeability tests, the permeability coefficient may be in the range of 1×10^{-8} to 1×10^{-10} cm³/s per cm² (area of concrete under test) per cm (thickness of concrete section under test). Air voids in well compacted mature concrete may occupy 1 percent of the volume of the concrete. As an example of the effect of items (a) and (b) only, when concrete has been artificially dried and then placed in water without any applied pressure,

the accepted absorption of good quality concrete should not exceed 6.5 per cent by mass of the concrete in 24 hours. For concrete pressure pipe, 900 mm diameter, under a test pressure of 100 m head, a figure of 6 percent for artificially dried concrete may amount to about 48 000 l/km in 24 hours. For concrete pipelines, the standard of acceptability for non-absorbent pipelines quoted above can be achieved only when absorption is complete. In the case of concrete pipes, the attainment of this standard may be costly and time consuming process with no equivalent advantage obtained in the form of a higher standard of completed pipeline and it may be preferable to specify for the rate of loss of water from the container a figure more appropriate to the absorption characteristics of concrete and thus larger than the figure quoted for non-absorbent pipelines. A figure of 3 litres per mm diameter per km per 24 hours per 30 m head is recommended.

15.5.4 Leak Detection — If the test is not satisfactory, the fault should be found and rectified. Where there is difficulty in locating a fault, the section under test should be subdivided and each part tested separately.

Method employed for finding leakage include:

- a) visual inspection of each joint if not covered by the backfill;
- b) use of a bar probe to detect signs of water in the vicinity of joints if backfilled;
- c) aural inspection using a stethoscope or listening stick in contact with the pipeline;
- d) use of an electronic listening device which detects and amplifies the sound of escaping fluid (actual contact between the probe and the pipe is not essential);
- e) injection of a dye into test water (particularly suitable in waterlogged ground but subject to approval by the appropriate authority); and
- f) introduction of nitrous oxide in solution into the test water, using an infra-red gas concentration indicator to detect the presence of any nitrous oxide that has escaped through the leakage.

15.5.5 Final Testing — After all sections have been jointed together on completion of section testing, a test on the complete pipeline should be carried out. This test should be carried out at a pressure not less than the working pressure of the pipeline, care being taken to ensure that the pressure at the lowest point in the pipeline does not exceed the maximum. During the test, an inspection should be made of all work which has not been subjected to sectional tests.

APPENDIX A

(Clauses 4.1, 7.1, 8.2, B-1.1 and B-2.1)

FORMULAE FOR CALCULATION OF VERTICAL LOADS ON
PIPES DUE TO FILL MATERIAL

A-1. TRENCH CONDITION

A-1.1 The pipe is laid in a narrow trench excavated in earth or rock (see Appendix B). The load which reaches the pipe is less than the weight of the fill material above the pipe because of the friction between the fill material and the sides of the trench. The frictional resistance diminishes with increase in trench width at the level of the top of the pipe (see Fig. 14).

A-1.2 W_e is calculated as follows:

$$W_e = C_t w B^2$$

where C_t has the values given in Fig. 4.

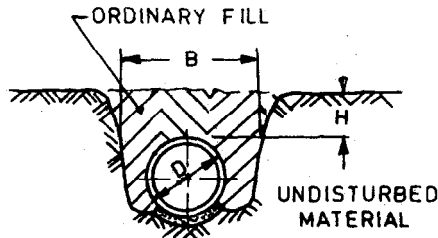

FIG. 14 PIPE LAID UNDER TRENCH CONDITION

A-2. POSITIVE PROJECTION EMBANKMENT CONDITION

A-2.1 The pipe is laid in a shallow excavation with its top projecting above the adjacent undisturbed foundation material. The vertical load transmitted to the pipe is usually greater than the load due to the weight of the fill material above the top of the pipe because settlement of the fill material adjacent to the pipe transfers additional load to the pipe by friction. It is an advantage therefore, to compact the fill material adjacent to the pipe to maximum density (see Fig. 15).

A-2.2 W_e is calculated as follows:

$$W_e = C_e w D^3$$

where C_e has the values given in Fig. 1.

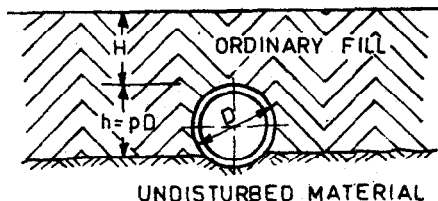

FIG. 15 PIPE LAID UNDER POSITIVE PROJECTION EMBANKMENT CONDITION

A-3. WIDE TRENCH CONDITION

A-3.1 The pipe is laid in a wide trench (see Appendix B). The frictional resistance between the fill material and the walls of the trench has less effect than in the case of an ordinary trench, and the installation conditions may vary between trench conditions and positive projection conditions. The lesser of the loads calculated assuming trench conditions and positive projection conditions shall be adopted when calculating the required minimum test load (see Fig. 16).

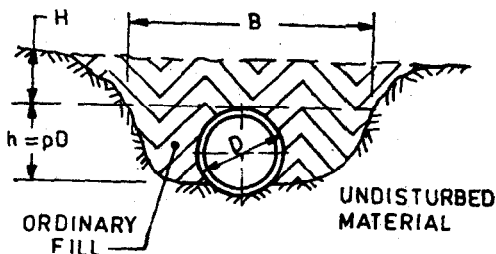

FIG. 16 PIPE LAID UNDER WIDE TRENCH CONDITION

A-3.2 W_e is calculated as follows:

$$W_e = C_t w B^2 \text{ for trench conditions, and}$$

$$W_e = C_e w D^2 \text{ for positive projection conditions.}$$

where C_t has the values given in Fig. 4, and C_e has the values given in Fig. 1.

A-4. IMPERFECT TRENCH CONDITION

A-4.1 The pipe is first laid under positive projection conditions (see Appendix B) and the fill material is placed and compacted to the designed height (see Appendix C, Example 7). A trench of width equal to the outside diameter of the pipe is then excavated in the compacted fill material directly over the pipe and to within 300 mm of the top of the pipe. This trench is then refilled with loose material such as straw, hay, leaves or brush, and left unconsolidated. The embankment is then completed and consolidated (see Fig. 17).

The load transmitted to the pipe under these conditions is less than the load transmitted under positive projection conditions.

A-4.2 W_e is calculated as follows:

$$W_e = C_n w B^2$$

where C_n has the values given in Fig. 2.

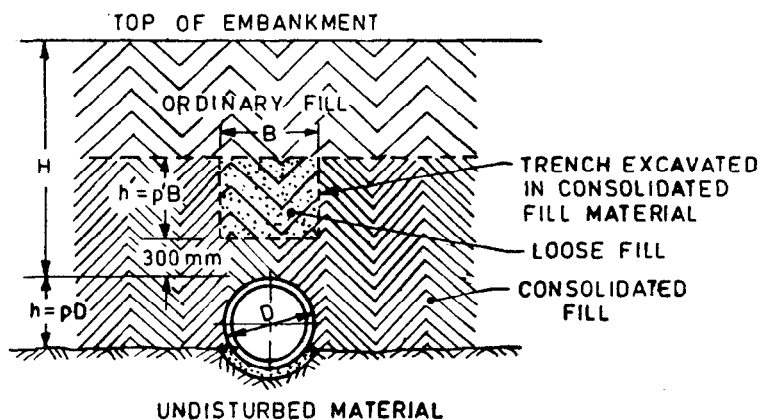

FIG. 17 PIPE LAID UNDER IMPERFECT TRENCH CONDITION

A-5 NEGATIVE PROJECTION EMBANKMENT CONDITION

A-5.1 The pipe is laid in a narrow trench excavated in undisturbed earth or rock (see B-1 and B-8). The trench is loosely filled with fill material and the fill material is then built up to the designed height as shown in Fig. 18. The load transmitted to the pipe under these conditions tends to be intermediate between the load transmitted under trench conditions and the load transmitted under positive projection conditions.

A-5.2 W_e is calculated as follows:

$$W_e = C_n w B^2$$

where C_n has the values given in Fig. 2.

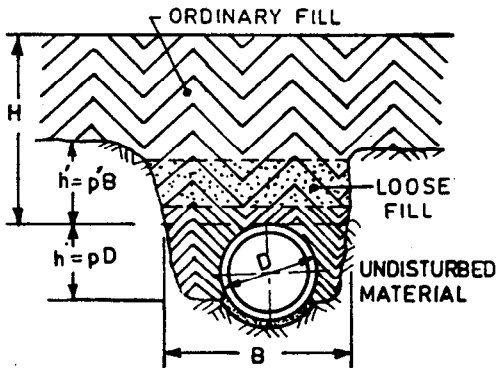

FIG. 18 PIPE LAID UNDER NEGATIVE PROJECTION EMBANKMENT CONDITION

APPENDIX B

(Clauses 4.1, 6.2, 10.1, 10.2, 12.1, A-1.1, A-3.1,
A-4.1 and A-5.1)

TRENCH CONDITION AND NEGATIVE AND POSITIVE PROJECTION CONDITIONS UNDER DIFFERENT BEDDING AND FOUNDATION CONDITIONS

B-1. TRENCH CONDITION AND NEGATIVE PROJECTION CONDITION: TYPE A BEDDING — ROCK FOUNDATION

B-1.1 Description — The pipe is evenly supported on a continuous concrete cradle, of monolithic cross section if unreinforced.

The thickness of the cradle under the pipe is sufficient to allow adequate compaction of the concrete, but in no case it shall be less than twice the nominal size of the coarse aggregate or 50 mm whichever is the greater.

The cradle extends up the barrel of the pipe for the vertical height XD assumed in the design.

The compressive strength of the concrete in the cradle shall be not less than 15 N/mm^2 at 28 days.

Selected fill material, free from clay lumps retained on a 75-mm sieve and from stones retained on a 26.5-mm sieve, is placed around and over the pipe and compacted in layers not exceeding 150 mm thick to a consolidated height of 300 mm above the top of the pipe.

For normal trench conditions the remainder of the trench is refilled to natural surface with ordinary fill material (see Fig. 19).

For negative projection conditions (see Appendix A), the remainder of the trench to natural surface level is refilled without compaction. The embankment is then built up. Ordinary fill material may be used above 300 mm from the top of the pipe (see Fig. 20).

NOTE — If elliptically reinforced pipes are to be laid on Type A bedding the pipes may have to be specially designed for the purpose.

B-1.2 Settlement ratio r_b shall be as follows:

- a) For negative projection condition $r_b = -1.0$, and
- b) For trench condition — not applicable.

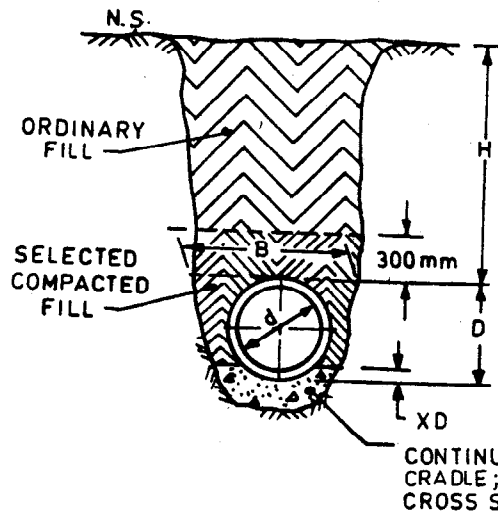

FIG. 19 PIPE UNDER TRENCH CONDITION:
TYPE A BEDDING: ROCK
FOUNDATION

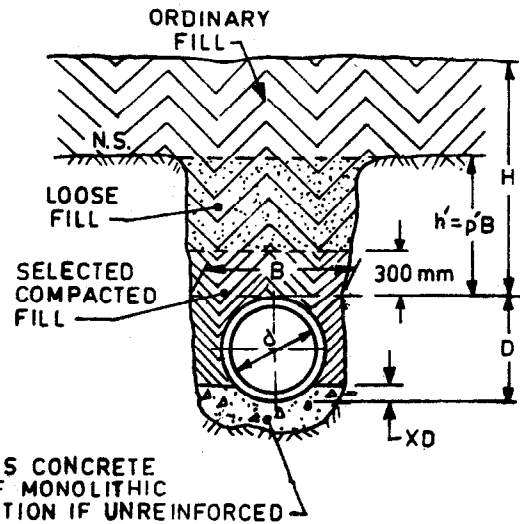

FIG. 20 PIPE UNDER NEGATIVE PROJECTION
CONDITION: TYPE A BEDDING:
ROCK FOUNDATION

B-1.3 Load factor F_t shall be as follows:

<i>Ratio X</i>	1/10	2/10	3/10	4/10
<i>Load factor, F_t</i>	1.7	2.6	3.6	4.7

NOTE — Provided the pipe is unreinforced or suitably reinforced, a particular type of cradle will increase the load factor for every class of pipe by approximately the same amount, not the same percentage.

B-2. TRENCH CONDITION AND NEGATIVE PROJECTION CONDITION: TYPE A BEDDING — EARTH FOUNDATION

B-2.1 Description — The pipe is evenly supported on a continuous concrete cradle, of monolithic cross-section if unreinforced.

The width of the cradle is not less than the external diameter of the pipe plus 200 mm.

The thickness of the cradle under the pipe is not less than one-quarter of the internal diameter of the pipe and the cradle extends up the barrel of the pipe for a vertical distance equal to X times the external diameter of the pipe, where $X = 1/4$ to $1/6$.

The compressive strength of the concrete in the cradle shall be not less than 15 N/mm^2 at 28 days.

Selected fill material, free from clay lumps retained on a 75-mm sieve and from stones retained on a 26.5-mm sieve, is placed around and over the pipe and compacted in layers not exceeding 150 mm thick to a consolidated height of 300 mm above the top of the pipe.

For normal trench conditions the remainder of the trench is refilled to natural surface with ordinary fill material (see Fig. 21).

For negative projection conditions (see Appendix A) the remainder of the trench to natural surface is refilled without compaction. The embankment is then built up. Ordinary fill material may be used above 300 mm from the top of the pipe (see Fig. 22).

NOTE — If elliptically reinforced pipes are to be laid on Type A bedding the pipes may have to be specially designed for the purpose.

B-2.2 Settlement ratio r_s shall be as follows:

- For negative projection condition, $r_s = -0.5$
- For trench condition — not applicable.

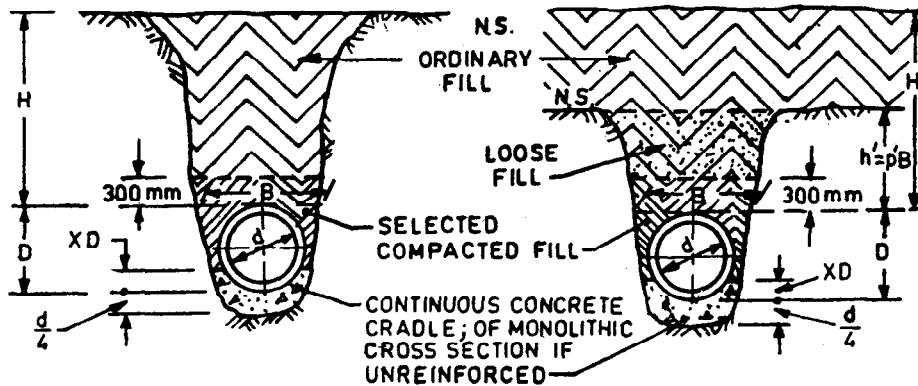

FIG. 21 PIPE UNDER TRENCH CONDITION:
TYPE A BEDDING: EARTH
FOUNDATION

FIG. 22 PIPE UNDER NEGATIVE
PROJECTION CONDITION:
TYPE A BEDDING: EARTH
FOUNDATION

B-2.3 Load factor, F_t depending on ratio X shall be as follows:

Class of Pipe	Ratio X	
	1/4	1/6
NP2	3	2.6
NP3, NP4 and stronger	2.2	1.9

NOTE — Provided the pipe is unreinforced or suitably reinforced, a particular type of cradle will increase the load factor for every class of pipe by approximately the same amount, not the same percentage.

B-3. TRENCH CONDITION AND NEGATIVE PROJECTION CONDITION: TYPE B BEDDING — ROCK FOUNDATION

B-3.1 Description — The pipe is evenly bedded on a continuous cushion of compacted sand or earth. The thickness of the cushion under the pipe is not less than 40 mm for each meter height of the fill material over the top of the pipe or 200 mm whichever is the greater. Care is taken to ensure that the pipe is not supported solely on the socket, if any, for example, a chase is excavated in the foundation material to prevent the socket from bearing on the foundation.

The cushion extends up the barrel of the pipe for a vertical height of not less than one-quarter of the external diameter of the pipe.

The width of the cushion is not less than the external diameter of the pipe plus 200 mm.

Selected fill material, free from clay lumps retained on a 75-mm sieve and from stones retained on a 26.5-mm sieve, is placed around and over the pipe and compacted in layers not exceeding 150 mm thick to a consolidated height of 300 mm above the top of the pipe.

For normal trench conditions, the remainder of the trench is refilled to natural surface level with ordinary fill material (*see* Fig. 23).

For negative projection conditions, the remainder of the trench to natural surface level is refilled without compaction. The embankment is then built up (*see* Fig. 24). Ordinary fill material may be used above 300 mm from the top of the pipe.

B-3.2 Settlement ratio r_s shall be as follows:

- For negative projection condition, $r_s = -1.0$, and
- For trench condition — not applicable.

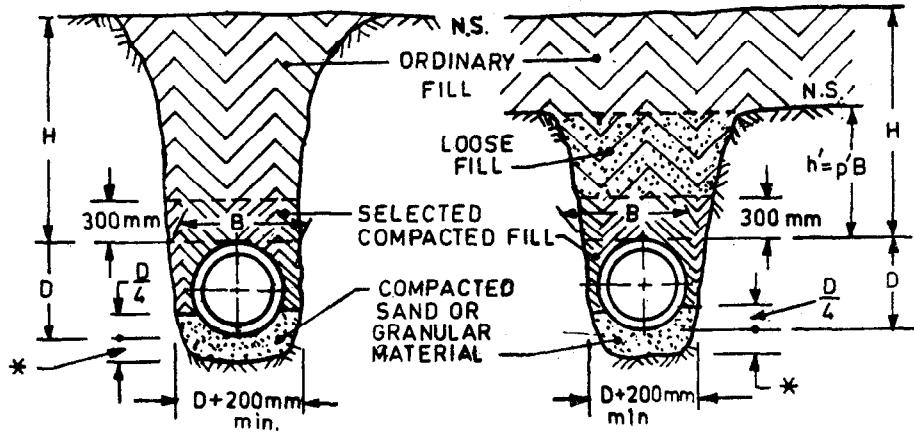

*40 mm per metre of H or 200 mm whichever is greater

FIG. 23 PIPE UNDER TRENCH
CONDITION: TYPE B
BEDDING: ROCK
FOUNDATION

FIG. 24. PIPE UNDER NEGATIVE
PROJECTION CONDITION:
TYPE B BEDDING: ROCK
FOUNDATION

B-3.3 Load factor F_t shall be as follows:

- a) If the fill material at the sides of the pipe and to a height of 300 mm above the top of the pipe is compacted to the same density as that of the foundation material or to 90 percent of the maximum density at optimum moisture content as determined by a suitable method of test, a load factor of 2.5 shall be used.
- b) If the fill material at the sides of the pipe is compacted to a lesser density than specified in (a) above, a load factor less than 2.5, depending on the density achieved, should be used. The minimum load factor that shall be used is 1.9.

B-4. TRENCH CONDITION AND NEGATIVE PROJECTION CONDITION: TYPE B BEDDING -- EARTH FOUNDATION

B-4.1 Description — The pipe is evenly bedded on a continuous cushion of compacted sand or earth. The thickness of the cushion under the pipe is not less than 75 mm. The foundation is shaped concentrically with the pipe for a width not less than 0.6 times the external diameter of the pipe, as shown in Fig. 25 and 26.

Fill material, free from clay lumps retained on a 75-mm sieve and from stone retained on a 26.5-mm sieve, is placed around and over the pipe and compacted in layers not exceeding 150 mm thick to a consolidated height of 300 mm above the top of the pipe.

For normal trench conditions the remainder of the trench is refilled to natural surface level with ordinary fill material.

For negative project conditions the remainder of the trench to natural surface level is refilled without compaction, and the embankment is then built up. Ordinary fill material may be used above 300 mm from the top of the pipe.

B-4.2 Settlement ratio r_s shall be as follows:

- a) For negative projection condition $r_s =$ — 0.5, and
- b) For trench condition — not applicable.

B-4.3 Load factor, F_t shall be as follows:

- a) If the fill material at the sides of the pipe and to a height of 300 mm above the top of the pipe is compacted to the same density as that of the foundation material, or to 90 percent of the maximum density at optimum moisture content as determined by a suitable method of test, a load factor of 2.5 shall be used; and

- b) If the fill material at the sides of the pipe is compacted to a lesser density than specified in (a) above, a load factor less than 2.5, depending on the density achieved, should be used. The minimum load factor that shall be used is 1.9.

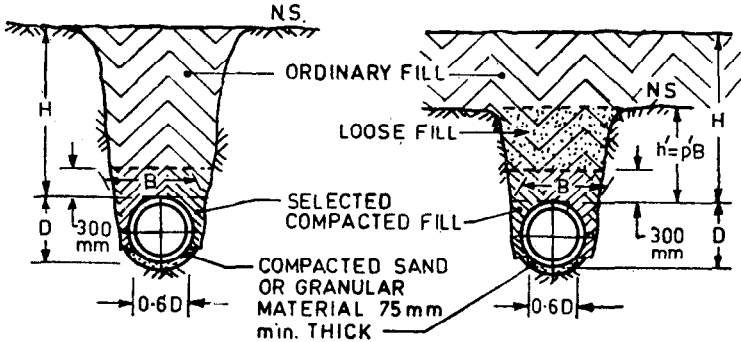

FIG. 25 PIPE UNDER TRENCH
CONDITION: TYPE B
BEDDING: EARTH
FOUNDATION

FIG. 26 PIPE UNDER NEGATIVE
PROJECTION CONDITION:
TYPE B BEDDING: EARTH
FOUNDATION

B-5. TRENCH CONDITION AND NEGATIVE PROJECTION CONDITION: TYPE C BEDDING — ROCK FOUNDATION

B-5.1 Description — The pipe is evenly bedded on a continuous cushion of compact sand or earth. The thickness of the cushion under the pipe is not less than 20 mm for each meter height of fill material above the top of the pipe or 150 mm, whichever is the greater. The cushion extends up the barrel of the pipe for a vertical height for not less than one-fifth of the external diameter of the pipe.

The width of the cushion is not less than the external diameter of the pipe plus 200 mm.

Fill material, free from clay lumps retained on a 75-mm sieve and from stones retained on a 26.5-mm sieve, is placed around and over the pipe and compacted in layers not exceeding 150 mm thick to a consolidated height of 150 mm above the top of the pipe.

For normal trench conditions, the remainder of the trench is refilled to natural surface level with ordinary fill material.

For negative projection conditions the remainder of the trench to natural surface level is refilled without compaction. The embankment is then built up. Ordinary fill material may be used above 300 mm from the top of the pipe (see Fig. 27 and 28).

B-5.2 Settlement ratio r_s shall be as follows:

- a) For negative projection condition, $r_s = -1.0$, and
- b) For trench condition — not applicable.

B-5.3 Load factor F_t shall be as follows:

- a) If the fill material at the sides of the pipe and to a height of 150 mm above the top of the pipe is compacted to the same density as that of the foundation material or to 90 percent of the maximum density at optimum moisture content as determined by a suitable method of test, a load factor of 1.9 shall be used.
- b) If the fill material at the sides of the pipe is compacted to a lesser density than specified in (a) above, a load factor less than 1.9, depending on the density achieved, should be used. The minimum load factor that shall be used is 1.5.

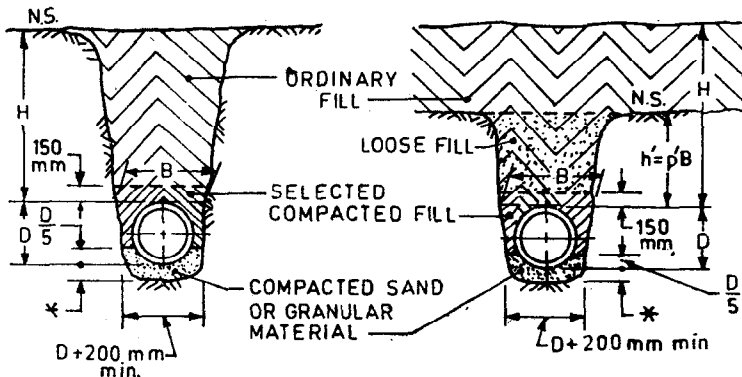

*20 mm per metre of H or 150 mm whichever is greater.

FIG. 27 PIPE UNDER TRENCH
CONDITION: TYPE C
BEDDING: ROCK
FOUNDATION

FIG. 28 PIPE UNDER NEGATIVE
PROJECTION CONDITION:
TYPE C BEDDING:
ROCK FOUNDATION

B-6. TRENCH CONDITION AND NEGATIVE PROJECTION CONDITION: TYPE C BEDDING — EARTH FOUNDATION

B-6.1 Description — The pipe is evenly supported on an earth foundation shaped to fit the barrel of the pipe for a width not less than one-half of the external diameter of the pipe.

Fill material, free from clay lumps retained on a 75-mm sieve and from stones retained on a 26.5-mm sieve, is placed around and over the pipe and compacted in layers not exceeding 150 mm thick, to a consolidated height of 150 mm above the top of the pipe.

For normal trench conditions the remainder of the trench is refilled to natural surface level with ordinary fill material.

For negative projection conditions, the remainder of the trench to natural surface level is refilled without compaction. Ordinary fill material may be used above 300 mm from the top of the pipe. The embankment is then built up (see Fig. 29 and 30).

B-6.2 Settlement ratio r_s shall be as follows:

- For negative projection condition, $r_s = -0.5$, and
- For trench condition — not applicable.

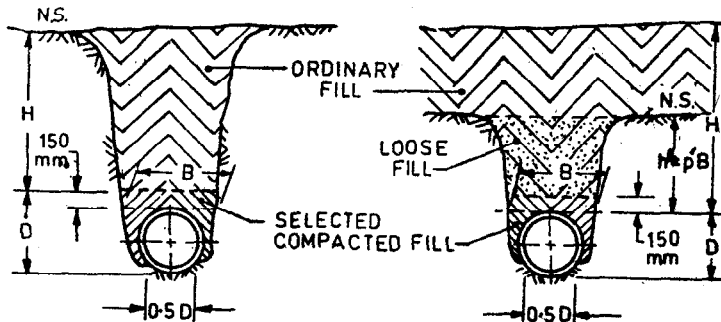

FIG. 29 PIPE UNDER TRENCH
CONDITION: TYPE C
BEDDING: EARTH
FOUNDATION

FIG. 30 PIPE UNDER
NEGATIVE PROJECTION
CONDITION: TYPE C
BEDDING: EARTH
FOUNDATION

B-6.3 Load factor F_t shall be as follows:

- a) If the fill material at the sides of the pipe and to a height of 150 mm above the top of the pipe is compacted to the same density as that of the foundation material, or to 90 percent of the maximum density at optimum moisture content as determined by a suitable method of test, a load factor of 1.9 shall be used.
- b) If the fill material at the sides of the pipe is compacted to a lesser density than specified in (a) above, a load factor less than 1.9 depending on the density achieved should be used. The minimum load factor that shall be used is 1.5.

**B-7. TRENCH CONDITION AND NEGATIVE PROJECTION
CONDITION: TYPE D BEDDING — ROCK FOUNDATION**

B-7.1 Description — The pipe is bedded on a continuous cushion of earth not less than 100 mm thick, on a foundation shaped approximately concentric with the barrel of the pipe, as shown in Fig. 31 and 32.

The cushion extends up the barrel of the pipe for a vertical height not less than one-tenth of the external diameter of the pipe.

- No special attempt is made to select and compact the fill material.

The use of this method is not recommended.

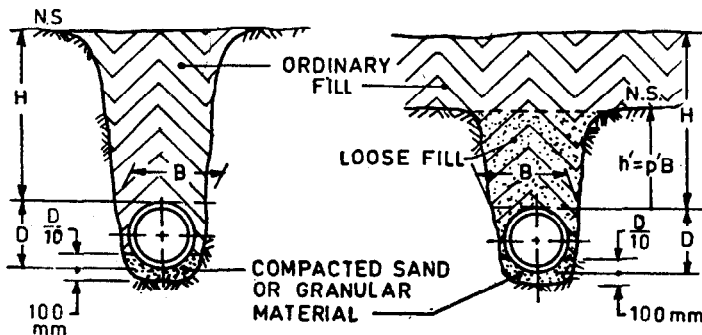

FIG. 31 PIPE UNDER TRENCH
CONDITION TYPE D
BEDDING: ROCK
FOUNDATION

FIG. 32 PIPE UNDER NEGATIVE
PROJECTION CONDITION:
TYPE D BEDDING:
FOUNDATION

B-7.2 Settlement ratio r_s shall be as follows:

- For negative projection condition, $r_s = -1.0$, and
- For trench condition — not applicable.

B-7.3 Load factor F_t shall be as follows:

A load factor of 1.1 shall be used.

NOTE — A load equal to three quarters of the weight of water required to fill the pipe should be added to the calculated external load on the pipe (see 12).

B-8. TRENCH CONDITION AND NEGATIVE PROJECTION CONDITION: TYPE D BEDDING — EARTH FOUNDATION

B-8.1 Description — The pipe is laid on a foundation which does not fit the barrel of the pipe, but if the pipe is socketed a chase is made in the foundation to prevent the socket from bearing on the foundation. No special attempt is made to select and compact the fill material (see Fig. 33 and 34).

The use of this method is not recommended.

B-8.2 Settlement ratio r_s shall be as follows:

- For negative projection condition, $r_s = -0.5$, and
- For trench condition — not applicable.

B-8.3 Load factor F_t shall be 1.1.

NOTE — A load equal to three-quarters of the weight of water required to fill the pipe shall be added to the calculated external load on the pipe (see 12).

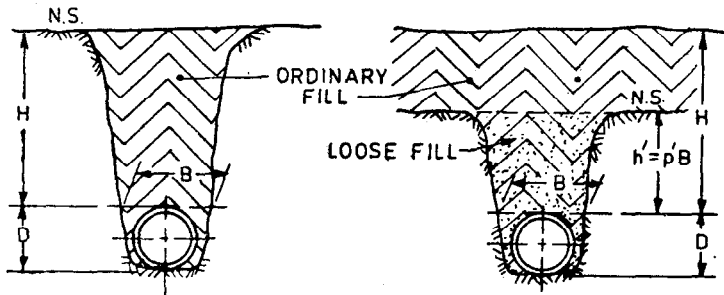

FIG. 33 PIPE UNDER TRENCH
CONDITION: TYPE D
BEDDING: EARTH
FOUNDATION

FIG. 34 PIPE UNDER NEGATIVE
PROJECTION CONDITION:
TYPE D BEDDING:
EARTH FOUNDATION

B-9. POSITIVE PROJECTION CONDITION INCLUDING WIDE TRENCH CONDITION, AND IMPERFECT TRENCH CONDITION: TYPE A BEDDING — ROCK FOUNDATION

B-9.1 Description — The pipe is evenly supported on a continuous concrete cradle; of monolithic cross section if unreinforced.

The width of the cradle is not less than the external diameter of the pipe plus 200 mm.

The thickness of the cradle under the pipe is not less than twice the nominal size of the coarse aggregate in the concrete or 50 mm, whichever is the greater.

The cradle extends up the barrel of the pipe for a vertical distance equal to one-quarter of the external diameter of the pipe.

The compressive strength of the concrete in the cradle is not less than 15 N/mm² at 28 days.

Selected fill material, free from clay lumps retained on a 75-mm sieve and from stones retained on a 26.5-mm sieve, is placed around and over the pipe and compacted in layers not exceeding 150 mm above the top of the pipe. The compacted selected fill material extends at least 300 mm from each side of the pipe (see Fig. 35).

NOTE — If elliptically reinforced pipes are installed on Type A bedding, the pipes may have to be specially designed for the purpose.

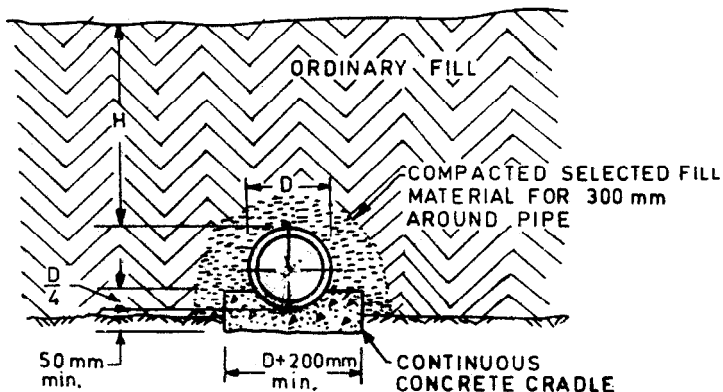

FIG. 35 PIPE UNDER POSITIVE PROJECTION CONDITION: TYPE A BEDDING: ROCK FOUNDATION

B-9.2 Projection ratio p shall be 0.75.

B-9.3 Settlement ratio r_s shall be as follows:

- a) For positive projection condition and wide trench condition, $r_s = 1.0$: and
- b) For imperfect trench condition, $r_s = -1.0$.

B-9.4 Load factor F_e shall be as follows:

$p = 0.75$		
$\frac{H}{D}$	r_s	
	+ 1.0	- 1.0
	F_e	
0.5	6.5	5
1.0	4.8	5
1.5	4.3	5
2.0	4.0	5
3.0	3.8	5
5.0	3.8	5
10.0	3.7	5

NOTE — Provided the pipe is unreinforced or suitably reinforced, a particular type of cradle will increase the load factor for every class of pipe by approximately the same amount, not the same percentage.

B-10. POSITIVE PROJECTION CONDITION INCLUDING WIDE TRENCH CONDITION, AND IMPERFECT TRENCH CONDITION: TYPE A BEDDING — EARTH FOUNDATION

B-10.1 Description — The pipe is evenly supported on a continuous concrete cradle, of monolithic cross-section if unreinforced.

The thickness of the cradle under the pipe is not less than one-quarter of the internal diameter of the pipe. The cradle extends up the barrel of

the pipe for a vertical height equal to one-quarter of the external diameter of the pipe.

The compressive strength of the concrete in the cradle is not less than 15 N/mm^2 at 28 days.

Selected fill material, free from clay lumps retained on 75-mm sieve and from stones retained on a 26.5-mm sieve, is placed around and over the pipe and compacted in layers not exceeding 150 mm thick to a consolidated height of 300 mm above the top of the pipe. The compacted selected fill material extends at least 300 mm from each side of the pipe (see Fig. 36).

NOTE — If elliptically reinforced pipes are to be installed on Type A bedding the pipes may have to be specially designed for the purpose.

B-10.2 Projection ratio p shall be 0.75.

B-10.3 Settlement ratio r_s shall be as follows:

- a) For positive projection condition and wide trench condition, $r_s = 0.7$ to 1.0 ; and
- b) For imperfect trench condition $r_s = -0.5$.

B-10.4 Load factor F_e shall be as follows:

$p = 0.75$		
$\frac{H}{D}$	r_s	
	0.7 to 1.0	- 0.5
0.5 1.0 1.5 2.0 3.0 5.0 10.0	F_e	
	6.5	5
	4.8	5
	4.3	5
	4.0	5
	3.8	5
	3.8	5
3.7	5	

NOTE — Provided the pipe is unreinforced or suitably reinforced, a particular type of cradle will increase the load factor for every class of pipe by approximately the same amount, not the same percentage.

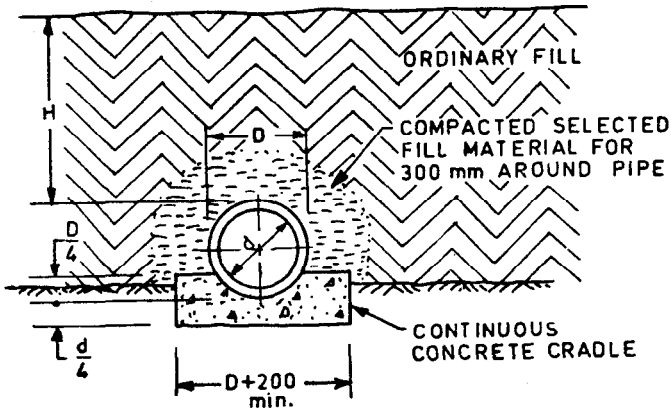

FIG. 36 PIPE UNDER POSITIVE PROJECTION CONDITION:
TYPE A BEDDING: EARTH FOUNDATION

B-11. POSITIVE PROJECTION CONDITION INCLUDING WIDE TRENCH CONDITION, AND IMPERFECT TRENCH CONDITION: TYPE B BEDDING — ROCK FOUNDATION

B-11.1 Description — The pipe is evenly bedded on a continuous cushion of sand or earth and is laid so that the projection ratio does not exceed 0.7. The thickness of the cushion under the pipe is not less than 40 mm for each metre of fill material over the top of the pipe or 200 mm, whichever is the greater (see Fig. 37).

The cushion extends up the barrel of the pipe for a vertical height of not less than one-tenth of the external diameter of the pipe.

The width of the cushion is not less than the external diameter of the pipe plus 100 mm.

Fill material, free from clay lumps retained on a 75-mm sieve and from stones retained on 26.5-mm sieve, is compacted around the pipe in layers not exceeding 150 mm thick to a consolidated height of 300 mm above the top of the pipe.

Up to the level of the undisturbed rock, the fill material should be free from clay and stones and should be carefully tamped around the pipe to ensure thorough compaction.

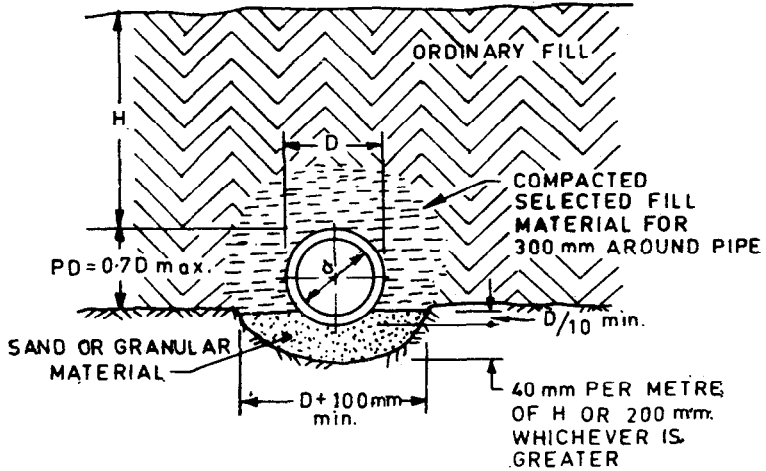

FIG. 37 PIPE UNDER POSITIVE PROJECTION CONDITION:
TYPE B BEDDING: ROCK FOUNDATION

The compacted fill material extends at least 300 mm from each side of the pipe.

B-11.2 Settlement ratio r_s shall be as follows:

- a) For positive projection condition and wide trench condition, $r_s = +1.0$; and
- b) For imperfect trench condition, $r_s = -1.0$.

B-11.3 Load factor F_e shall be as follows:

$p = 0.7$			
$\frac{H}{D}$	r_s		
	+ 1.0	- 1.0	
0.5 1.0 1.5 2.0 3.0 5.0 10.0	F_e		
		2.8	2.9
		2.5	2.9
		2.4	2.9
		2.4	2.9
		2.3	2.9
		2.3	2.9
		2.3	2.9

$p = 0.5$			
$\frac{H}{D}$	r_s		
	+ 1.0	- 1.0	
0.5 1.0 1.5 2.0 3.0 5.0 10.0	F_e		
		2.3	2.7
		2.3	2.7
		2.2	2.7
		2.2	2.7
		2.2	2.7
		2.2	2.7
		2.2	2.7

B-12. POSITIVE PROJECTION CONDITION INCLUDING WIDE TRENCH CONDITION, AND IMPERFECT TRENCH CONDITION: TYPE B BEDDING — EARTH FOUNDATION

B-12.1 Description—The pipe is evenly bedded on a continuous cushion of sand or earth and is installed so that the projection ratio does not exceed 0.7 (see Fig. 38).

The thickness of the cushion under the pipe is not less than 75 mm.

The foundation is shaped concentrically with the barrel of the pipe so that the cushion extends up the barrel for a vertical height of not less than one-tenth of the external diameter of the pipe.

Fill material, free from clay lumps retained on a 75-mm sieve and from stones retained on a 26.5-mm sieve, is compacted around the pipe in layers not exceeding 150 mm thick to a consolidated height of 300 mm above the top of the pipe.

Up to the level of the natural surface, the fill material should be free from clay and stones and should be carefully tamped around the pipe to ensure thorough compaction.

The compacted fill material extends at least 300 mm on each side of the pipe.

B-12.2 Settlement ratio r_s shall be as follows:

- For positive projection condition and wide trench condition, $r_s = +0.5$ to $+0.8$; and
- For imperfect trench condition, $r_s = -0.5$.

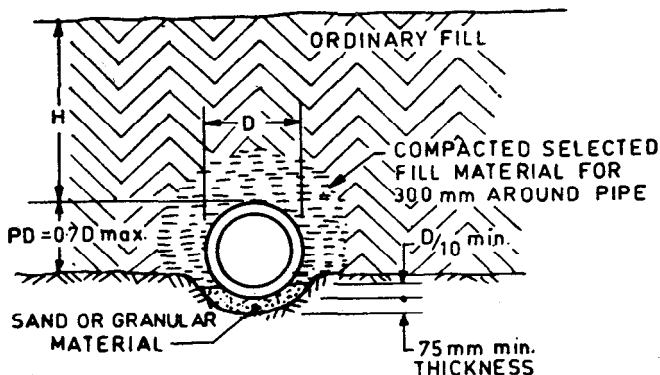

FIG. 38 PIPE UNDER POSITIVE PROJECTION CONDITION: TYPE B BEDDING: EARTH FOUNDATION

B-12.3 Load factor F_e shall be as follows:

$p = 0.7$		
$\frac{H}{D}$	r_B	
	+ 0.5 to + 0.8	- 0.5
0.5 1.0 1.5 2.0 3.0 5.0 10.0	F_e	
	2.8	2.9
	2.5	2.9
	2.4	2.9
	2.4	2.9
	2.3	2.9
	2.3	2.9
	2.3	2.9

$p = 0.5$		
$\frac{H}{D}$	r_B	
	+ 0.5 to + 0.8	- 0.5
0.5 1.0 1.5 2.0 3.0 5.0 10.0	F_e	
	2.3	2.7
	2.3	2.7
	2.3	2.7
	2.3	2.7
	2.3	2.7
	2.3	2.7
	2.3	2.7

B-13. POSITIVE PROJECTION CONDITION INCLUDING WIDE TRENCH CONDITION, AND IMPERFECT TRENCH CONDITION: TYPE C BEDDING — ROCK FOUNDATION

B-13.1 Description — The pipe is evenly bedded on a continuous cushion of sand or earth. The thickness of the cushion under the pipe is not less than 40 mm for each metre height of fill material over the top of the pipe or 150 mm, whichever is the greater (see Fig. 39).

The cushion extends up the barrel of the pipe for a vertical height of not less than one-tenth of the external diameter of the pipe.

The width of the cushion is not less than the external diameter of the pipe plus 100 mm.

Fill material, free from clay lumps retained on a 75-mm sieve and from stones retained on a 26.5-mm sieve, is compacted around the pipe in layers not exceeding 150 mm thick to a consolidated height of 300 mm above the top of the pipe. The compacted fill material extends at least 300 mm from each side of the pipe.

B-13.2 Settlement ratio r_s shall be as follows:

- a) For positive projection condition and wide trench condition, $r_s = +1.0$; and
- b) For imperfect trench condition, $r_s = -1.0$.

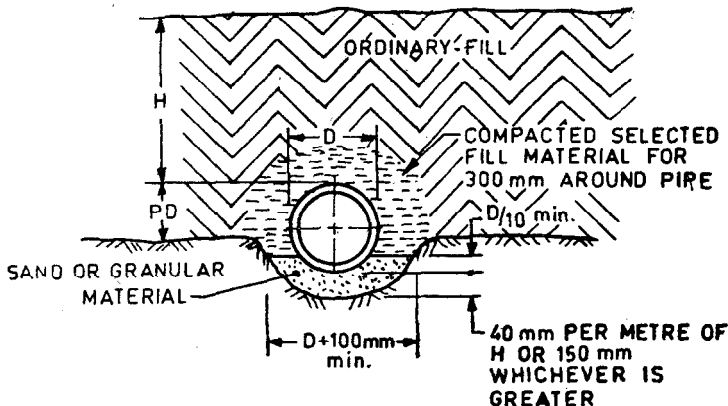

FIG. 39 PIPE UNDER POSITIVE PROJECTION CONDITION: TYPE C BEDDING: ROCK FOUNDATION

B-13.3 Load factor F_e shall be as follows:

$p = 0.9$		
$\frac{H}{D}$	r_s	
	+1.0	-1.0
F_e		
0.5	2.8	2.5
1.0	2.3	2.5
1.5	2.3	2.5
2.0	2.1	2.5
3.0	2.0	2.5
5.0	2.0	2.5
10.0	2.0	2.5

$p = 0.7$		
$\frac{H}{D}$	r_s	
	+1.0	-1.0
F_e		
0.5	2.2	2.3
1.0	2.0	2.3
1.5	2.0	2.3
2.0	1.9	2.3
3.0	1.9	2.3
5.0	1.9	2.3
10.0	1.9	2.3

$p = 0.5$		
$\frac{H}{D}$	r_s	
	+1.0	-1.0
F_e		
0.5	1.9	2.1
1.0	1.9	2.1
1.5	1.8	2.1
2.0	1.8	2.1
3.0	1.8	2.1
5.0	1.8	2.1
10.0	1.8	2.1

B-14. POSITIVE PROJECTION CONDITION INCLUDING WIDE TRENCH CONDITION, AND IMPERFECT TRENCH CONDITION: TYPE C BEDDING — EARTH FOUNDATION

B-14.1 Description — The pipe is evenly supported on a foundation shaped to fit the barrel of the pipe for a vertical height of not less than one-tenth of the external diameter of the pipe (see Fig. 40).

Fill material, free from clay lumps retained on a 75-mm sieve and from stones retained on a 26.5-mm sieve, is compacted around the pipe in layers not exceeding 150 mm thick to a consolidated height of not less than 300 mm over the top of the pipe. The compacted fill material extends at least 300 mm from each side of the pipe.

B-14.2 Settlement ratio r_s shall be as follows:

- a) For positive projection condition and wide trench condition, $r_s = +0.5$ to $+0.8$; and
- b) For imperfect trench condition, $r_s = -0.5$.

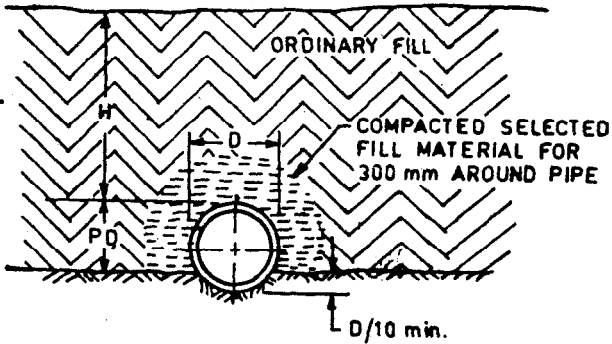

FIG. 40 PIPE UNDER POSITIVE PROJECTION CONDITION:
TYPE C BEDDING: EARTH FOUNDATION

B-14.3 Load factor F_o shall be as follows:

$p = 0.9$		
$\frac{H}{D}$	r_s	
	+0.5 to +0.8	-0.5
F_o		
0.5	2.8	2.5
1.0	2.3	2.5
1.5	2.3	2.5
2.0	2.1	2.5
3.0	2.0	2.5
5.0	2.0	2.5
10.0	2.0	2.5

$p = 0.7$		
$\frac{H}{D}$	r_s	
	+0.5 to +0.8	-0.5
F_o		
0.5	2.2	2.3
1.0	2.0	2.3
1.5	2.0	2.3
2.0	1.9	2.3
3.0	1.9	2.3
5.0	1.9	2.3
10.0	1.9	2.3

$p = 0.5$		
$\frac{H}{D}$	r_s	
	+0.5 to +0.8	-0.5
F_o		
0.5	1.9	2.1
1.0	1.9	2.1
1.5	1.8	2.1
2.0	1.8	2.1
3.0	1.8	2.1
5.0	1.8	2.1
10.0	1.8	2.1

B-15. POSITIVE PROJECTION CONDITION INCLUDING WIDE TRENCH CONDITION, AND IMPERFECT TRENCH CONDITION: TYPE D BEDDING — ROCK FOUNDATION

B-15.1 Description — The pipe is bedded on a continuous cushion of earth. The thickness of the cushion under the pipe is not less than 100 mm. No special attempt is made to select and compact the fill material (see Fig. 41).

The use of this method is not recommended.

B-15.2 Settlement ratio r_s shall be as follows:

- For positive projection condition and wide trench condition, $r_s = +1.0$; and
- For imperfect trench condition, $r_s = -1.0$.

B-15.3 Load factor, F_c shall be as follows:

$p = 0.9$		
$\frac{H}{D}$	r_s	
	+1.0	-1.0
0.5 1.0 1.5 2.0 3.0 5.0 10.0	F_c	
	1.4	1.4
	1.3	1.4
	1.3	1.4
	1.2	1.4
	1.2	1.4
	1.2	1.4
	1.2	1.4

$p = 0.7$		
$\frac{H}{D}$	r_s	
	+1.0	-1.0
0.5 1.0 1.5 2.0 3.0 5.0 10.0	F_c	
	1.3	1.3
	1.2	1.3
	1.2	1.3
	1.2	1.3
	1.2	1.3
	1.2	1.3
	1.2	1.3

$p = 0.5$		
$\frac{H}{D}$	r_s	
	+1.0	-1.0
0.5 1.0 1.5 2.0 3.0 5.0 10.0	F_c	
	1.2	1.2
	1.2	1.2
	1.1	1.2
	1.1	1.2
	1.1	1.2
	1.1	1.2
	1.1	1.2

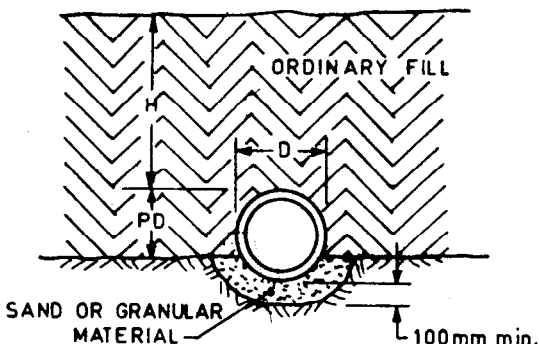

FIG. 41 PIPE UNDER POSITIVE PROJECTION CONDITION:
TYPE D BEDDING: ROCK FOUNDATION

B-16. POSITIVE PROJECTION CONDITION INCLUDING WIDE TRENCH CONDITION, AND IMPERFECT TRENCH CONDITION: TYPE D BEDDING — EARTH FOUNDATION

B-16.1 Description — The pipe is laid directly on a foundation which provides a continuous support for the pipe but which is not shaped concentrically with the barrel of the pipe. No special attempt is made to select the fill material or to compact the fill material around and over the pipe (see Fig. 42).

The use of this method is not recommended.

B-16.2 Settlement ratio r_s shall be as follows:

- a) For positive projection condition and wide trench condition, $r_s = +0.5$ to $+0.8$; and
- b) For wide trench condition, $r_s = -0.5$.

B-16.3 Load factor F_e shall be as follows:

$p = 0.9$		
$\frac{H}{D}$	r_s	
	+0.5 to +0.8	-0.5
F_e		
0.5	1.4	1.4
1.0	1.3	1.4
1.5	1.3	1.4
2.0	1.2	1.4
3.0	1.2	1.4
5.0	1.2	1.4
10.0	1.2	1.4

$p = 0.7$		
$\frac{H}{D}$	r_s	
	+0.5 to +0.8	-0.5
F_e		
0.5	1.3	1.3
1.0	1.2	1.3
1.5	1.2	1.3
2.0	1.2	1.3
3.0	1.2	1.3
5.0	1.2	1.3
10.0	1.2	1.3

$p = 0.5$		
$\frac{H}{D}$	r_s	
	+0.5 to +0.8	-0.5
	F_e	
0.5	1.2	1.2
1.0	1.2	1.2
1.5	1.1	1.2
2.0	1.1	1.2
3.0	1.1	1.2
5.0	1.1	1.2
10.0	1.1	1.2

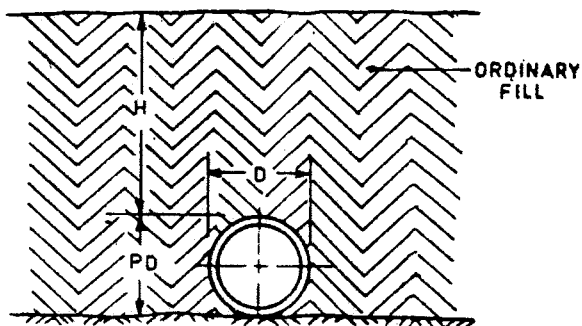

FIG. 42 PIPE UNDER POSITIVE PROJECTION CONDITION
TYPE D BEDDING: EARTH FOUNDATION

APPENDIX C

(Clause A-4.1)

EXAMPLES OF CALCULATIONS OF LOADS ON PIPES

Example 1:

Calculation of the required class of reinforced concrete pipe laid under trench conditions, given the following data:

Internal diameter of pipe, d	= 900 mm
Wall thickness, t	= 50 mm
External diameter, $D = 900 + 2 \times 50$	= 1 000 mm
Width of trench (assumed), B	
	= $D + 300$ = 1 300 mm
Depth of trench to pipe invert	= 3 m
Unit weight of fill material (wet clay), w	= 18 kN/m ³
Bedding and foundation material (see B-4) = Type B ₁ earth	
Depth of fill material over top of pipe, $H = 3.0 - 1.0$	= 2 m

Calculation

The vertical load W_e on the pipe due to the fill material is calculated from the formula:

$$W_e = C_t w B^2 \text{ (see A-1)}$$

The value of $C_t = 1.29$ is obtained from Fig. 4 using curve and ratio

$$\frac{H}{B} = \frac{2}{1.3} = 1.530$$

Hence the calculated load on the pipe, W_e

$$\begin{aligned} &= 1.29 \times 18 \times 1.3^2 \\ &= 39.24 \text{ kN/m} \end{aligned}$$

The load factor, $F_t = 1.9$ (from B-4)

The required minimum cracking load is

$$\frac{W_e}{F_t} = \frac{39.24}{1.9}$$

$$= 20.65 \text{ kN/m}$$

It follows from Table 2 of IS : 458-1971* that 900 mm NP2 class pipe which has a 0.25 mm crack test load of 24.5 kN/m is suitable.

Example 2:

Calculation of the required class of 450 mm diameter concrete pipe installed under trench conditions, given the following data:

Internal diameter of pipe, d = 450 mm

Wall thickness, t = 35 mm

External diameter of pipe, D
= 450 + 70 = 520 mm

Width of trench (assumed), B
= 520 + 300 = 820 mm

Depth of trench to pipe invert = 3 m

Unit weight of fill material (wet clay) = 18 kN/m³

Bedding and foundation material
= Type B, earth

Depth of fill material above top of
pipe, H = 3 - 0.820 = 2.180 m

Calculation

As in Example 1, $W_e = C_t w B^3$, and the value of $C_t = 1.9$ is obtained from Fig. 4 using curve B and ratio

$$\frac{H}{B} = \frac{2.18}{0.820} = 2.66$$

Hence $W_e = 1.9 \times 18 \times 0.82^3$
= 22.99 kN/m

The load factor $F_t = 1.9$ (from B-4)

a) For a reinforced concrete pipe, the required minimum test load is

$$\frac{W_e}{F_t} = \frac{22.99}{1.9} = 12.1 \text{ kN/m}$$

*Specification for concrete pipes (with and without reinforcements) (second revision).

It follows from table 2 of IS : 458-1971* that a 450 mm NP2 class pipe which has a 0.25 mm crack load of 14.5 kN/m is suitable.

- b) For an unreinforced concrete pipe the test load required should be at least 1.5 (see Note) times the calculated vertical load on the pipe divided by the load factor.

Hence the required minimum test load is

$$\frac{W_e \times 1.5}{1.9} = \frac{22.99 \times 1.5}{1.9} = 18.15 \text{ kN/m}$$

It follows from Table 1 of IS : 458-1971* that 450 mm dia NP1 class pipe which has a test load of 21.9 kN/m is suitable.

Hence, a choice between an unreinforced and a reinforced pipe is available.

NOTE — It is usual to apply a factor of safety of 1.5 to all unreinforced pipes for all installation conditions.

Example 3:

Calculation of the required class of 450 mm diameter pipe given the same conditions and data as in Example 2, with the addition of a uniformly distributed superimposed load U of 32 kN/m².

Calculation

The vertical load, W_u on on the pipe due to the superimposed load is calculated from the formula:

$$W_u = C_u BU$$

The value of $C_u = 0.49$ is obtained from Fig. 5 using curve B and the ratio

$$\frac{H}{B} = 2.66$$

Hence $W_u = 0.49 \times 0.82 \times 32 = 12.85$ kN/m and the total calculated load on the pipe

$$\begin{aligned} &= W_e + W_u = 22.99 + 12.85 \\ &= 35.84 \text{ kN/m} \end{aligned}$$

As before, $F_t = 1.9$

*Specification for concrete pipes (with and without reinforcements) (second revision).

For a reinforced concrete pipe the required minimum test load

$$\begin{aligned}
 &= \frac{W_e + W_u}{F_t} \\
 &= \frac{35.84}{1.9} \\
 &= 18.86 \text{ kN/m}
 \end{aligned}$$

It follows from the above that 450 mm NP2 class pipe will be obviously inadequate and 450 mm NP3 class pipe with 0.25 mm cracking load of 36.9 kN/m will have to be used. Alternatively, 450 mm NP2 class pipe with Type A bedding may be used.

Example 4:

Calculation of the required class of a 600 mm diameter concrete pipe, laid under trench conditions with the addition of a concentrated superimposed live load, given the following data:

External diameter of pipe, D	= 680 mm
Wall thickness (assumed), t	= 40 mm
Width of trench (assumed), B	
	= 680 + 300 = 980 mm
Unit weight of fill material (wet clay), w	= 18 kN/m ³
Bedding and foundation material	= Type B, earth
Depth of fill material above top of pipe, H	= 600 mm
Concentrated load on surface of fill material, P	= 45 kN
Impact factor, α	= 1.1
Length of a single pipe	= 2.5 m
Width of concentrated load in direction of the pipe, S	= 300 mm

Calculation

- a) Load due to fill material, W_e , is calculated from the formula $W_e = C_t w B^2$. The value of $C_t = 0.57$ is obtained from Fig. 4 using curve B and the ratio

$$\frac{H}{B} = \frac{0.6}{0.98} = 0.612$$

Hence $W_e = 0.57 \times 18 \times 0.982 = 9.85 \text{ kN/m}$

The load factor, $F_t = 1.9$

Hence the required minimum test load for the pipe to provide for the earth load

$$= \frac{W_e}{F_t} = \frac{9.85}{1.9} = 5.18 \text{ kN/m}$$

- b) The length of pipe, l , assumed to be supporting the concentrated load is calculated from the formula:

$$\begin{aligned} l &= 1.15H + 2D + S \\ &= 1.15 \times 0.6 + 2 \times 0.68 + 0.3 \\ &= 2.35 \text{ m} \end{aligned}$$

Then
$$\frac{l}{2H} = \frac{2.35}{2 \times 0.6} = 1.96$$

and
$$\frac{D}{2H} = \frac{0.68}{2 \times 0.6} = 0.566$$

The value $C_p = 0.58$ is obtained from Fig. 3. Therefore, the vertical load, W_e , on the pipe due to the superimposed load

$$\begin{aligned} &= \frac{0.58 \times 45 \times 1.1}{2.35} \\ &= 12.22 \text{ kN/m} \end{aligned}$$

The load factor, $F_p = 1.5$

Hence, the required minimum test load for the pipe to provide for the live load

$$= \frac{12.22}{1.5} = 8.146 \text{ kN/m}$$

The total required minimum test load

$$= 5.18 + 8.146 = 13.326 \text{ kN/m}$$

It follows from table 2 of IS : 458-1971* that 600 mm diameter NP2 class pipe with a 0.25 mm cracking load of 18.6 kN/m will be suitable.

Example 5:

Calculation of the permissible height of embankment over the top of a reinforced concrete pipe, given the following data:

*Specification for concrete pipes (with and without reinforcements) (second revision).

Internal diameter of pipe, d	= 600 mm
Wall thickness, t	= 40 mm
External diameter of pipe, D	= 680 mm
Unit weight of fill material (wet clay), w	= 18 kN/m ³
Bedding and foundation material (see B-12)	= Type B, earth
Class of pipe	= NP2
Settlement ratio (assumed), r_s	= 0.7
Distance from top of pipe down to undisturbed foundation level, h	= 300 mm
Projection ratio,	

$$p = \frac{h}{D} = \frac{0.3}{0.68} = 0.44$$

Calculation

Use a trial procedure. Assume the height of embankment over the top of the pipe H to be 3 m, then

$$\frac{H}{D} = \frac{3}{0.68} = 4.41 \text{ and from B-12, } F_e = 2.3$$

The test load, W_t , for a 600 class NP2 pipe = 18.6 kN/m

The permissible vertical load,

$$W_e = W_t \times F_e = 18.6 \times 2.3 = 42.78 \text{ kN/m}$$

Also as $W_e = C_e w D^2$ then

$$C_e = \frac{W_e}{w D^2} = \frac{42.78}{18 \times 0.68^2} = 5.14$$

The value of $\frac{H}{D} = 3.6$ is obtained from Fig. 1 using $C_e = 5.14$ and

$$r_s p = 0.7 \times 0.44 = 0.308$$

Hence the calculated permissible H

$$= 3.6 \times 0.68 = 2.45 \text{ m}$$

Check from B-12 that the difference between 3.6, the calculated value of $\frac{H}{D}$ and 4.41, assumed value of $\frac{H}{D}$, makes no difference to the value of the load factor.

Example 6:

Calculation of the required class of a reinforced concrete pipe laid under embankment conditions, given the following data:

Internal diameter of pipe, d	= 800 mm
Wall thickness (assumed), t	= 45 mm
External diameter of pipe, D	= 890 mm
Unit weight of fill material, w	= 18 kN/m ³
Bedding and foundation material (see B-13)	= Type C, Rock
Settlement ratio (assumed), r_s	= +1.0
Distance from top of the pipe down to undisturbed foundation level, h	= 450 mm

$$\text{Projection ratio, } p = \frac{h}{D} = \frac{0.45}{0.89} = 0.505$$

Height of embankment over top of pipe, $H = 4$ m

Calculation

The vertical load, W_e , on the pipe due to the fill material is calculated from the formula, $W_e = C_e w D^2$

The value $C_e = 6.8$ is obtained from Fig. 1 using the ratio,

$$\frac{H}{D} = \frac{4}{0.89} = 4.5 \text{ and } r_s p = 1 \times 0.505 = 0.505$$

$$\text{Hence } W_e = 6.8 \times 18 \times 0.89^2 = 96.953 \text{ kN/m}$$

From B-13, using $p = 0.5$, $r_s = +1.0$ and $\frac{H}{D} = 4.5$, the load factor, F_e is obtained as 1.8.

Therefore the required minimum test load

$$\frac{W_e}{F_e} = \frac{96.953}{1.8} = 53.86 \text{ kN/m}$$

It follows from Table 3 of IS : 458-1971* that 800 NP3 class pipe with 0.25 mm cracking load of 59.3 kN/m will be suitable.

*Specification for concrete pipes (with and without reinforcements) (second revision).

Example 7:

Calculation of the depth h' of imperfect trench (see A-4) required over a 1 600 mm diameter reinforced concrete pipe laid under imperfect trench conditions, given the following data:

External diameter of pipe, D	= 1 600 + 2 × 140	= 1 880 mm
Height of finished embankment above the top of the pipe, H		= 16 m
Class of pipe		= NP4
Bedding and foundation material (see B-12)		= Type B, earth
Unit weight of fill material (wet clay), w		= 18 kN/m ³
Settlement ratio (assumed), r_s		= -0.5

Calculation

Assume that the trench excavated over the pipe in the compacted fill material is of the same width as the outside diameter of the pipe, then the width of the trench,

$$B = 1.88 \text{ m and } \frac{H}{B} = \frac{H}{D} = \frac{16}{1.88} = 8.51$$

From Table 4 of IS : 458-1971* the 0.25 mm cracking load for 1 600 mm dia pipe is 119.6 kN/m.

From B-12 using $p = 0.7$, $r_s = -0.5$ and $\frac{H}{D} = 8.51$, F_e is obtained as 2.9.

Hence the maximum allowable vertical load on the pipe

$$W_e = 119.6 \times 2.9 = 346.84 \text{ kN/m}$$

Also $W_e = C_n w B^2$ (see A-4)

$$C_n (\text{Max}) = \frac{346.84}{w B^2} = \frac{346.84}{18 \times 1.88^2} = 5.45$$

From Fig. 2 using $\frac{H}{B} = 8.51$ and $r_s = -0.5$, the value of

*Specification for concrete pipes (with and without reinforcements) (second revision).

$C_n = 5.8$ for $p' = 0.5$ and $C_n = 4.9$ for $p' = 1.0$ respectively are obtained.

Hence by linear interpolation for $C_n = 5.45$, obtain $p' = 0.694$. Therefore the required depth of the imperfect trench $h' = p' \times B = 0.694 \times 1.88 = 1.30$ m.

To provide 300 mm fill material between the bottom of the imperfect trench and the top of the pipe, in order to protect the pipe against damage by excavating plant, the embankment should be consolidated to a height of 1.6 m above the top of the pipe before the imperfect trench is excavated approximately 1.30 m deep and 1.88 m wide (see A-4).

Example 8:

Calculation of the required class of a 300 mm diameter concrete pipe laid under trench conditions and supporting concentrated wheel loading from a DC3 aircraft, given the following data:

External diameter of pipe, D	$= 300 + 2 \times 30 = 360$ mm
Width of trench, B	$= 360 + 300 = 660$ mm
Single wheel load, P	$= 70$ kN
Height of cover to surface of pavement, H	$= 450$ mm
Impact factor, α	$= 1$
Unit weight of fill material (compacted to unit weight of undisturbed natural soil), w	$= 18$ kN/m ³
Bedding and foundation material (normal for air-field conditions) (see B-4)	$=$ Type B, earth
Width of load in direction of length of conduit	$=$ Disregarded
Depth to top of pipe from natural ground level, h'	$= 300$ mm
Thickness of pavement above natural ground level (negative trench condition)	$= 150$ mm

Calculation

a) Load due to fill material, W_e is calculated from the formula

$$W_e = C_n w B^3 \text{ (see A-4)}$$

The value $C_n = 0.6$ is obtained from Fig. 2 using the ratio

$$p' = \frac{h'}{B} = \frac{0.3}{0.66} = 0.45 \text{ say } = 0.5 \text{ and the ratio}$$

$$\frac{H}{B} = \frac{0.45}{0.66} = 0.68$$

Hence, $W_e = 0.6 \times 18 \times 0.66^2 = 4.70 \text{ kN/m}$

The load factor $F_t = 2.5$ (see B-4)

Therefore, the required minimum test load to provide for the earth load

$$= \frac{W_e}{F_t} = \frac{4.70}{2.5} = 1.88 \text{ kN/m}$$

b) Load due to the wheel load, W_c , is calculated from the formula

$$W_c = C_p \frac{P_a}{l} \text{ (see 9)}$$

The length of pipe, l , assumed to be supporting the concentrated load is calculated from the formula

$$\begin{aligned} l &= 1.15H + 2D + S \\ &= 1.15 \times 0.45 + 2 \times 0.36 + 0 \\ &= 1.24 \text{ m} \end{aligned}$$

The value $C_p = 0.42$ is obtained from Fig. 3, using the values for ratio $= \frac{1}{2H} = \frac{1.24}{2 \times 0.45} = 1.38$, and $\frac{D}{2H} = \frac{0.36}{2 \times 0.45} = 0.40$

$$\text{Hence } W_c = \frac{0.42 \times 70 \times 1}{1.24} = 23.71 \text{ kN/m}$$

The load factor F_p for a concentrated load is 1.5. Then the required minimum test load to provide for the wheel load $= \frac{23.71}{1.5} = 15.81 \text{ kN/m}$

So the total required minimum test load $= 1.88 + 15.81 = 17.69 \text{ kN/m}$. It follows from Table 2 of IS : 458-1971* that 300 mm NP2 class pipe with a 0.25 mm crack load of 11.8 kN/m will not be suitable and a special design would be necessary.

Example 9:

Calculation of the required class of a 1 100 mm diameter reinforced concrete pipe for a twin conduit in trench, given the following data:

External diameter of pipe, $D = 1\ 100 + 2 \times 115 = 1\ 330 \text{ mm}$

Width of trench, $B = 3\ 560 \text{ mm}$

Depth of fill material over top of pipe, $H = 7 \text{ m}$

*Specification for concrete pipes (with and without reinforcements) (second revision).

Unit weight of fill material (sandy clay), w = 17 kN/m³
 Bedding and foundation material (see B-6) = Type C, earth

The compaction of the fill material each side of each pipe is to comply with the minimum requirements of B-6 only, that is the attainment of maximum density at optimum moisture content will not be attempted.

Calculation

The vertical load, W_e on the plane through the top of the pipe is calculated from the formula

$$W_e = C_t w B^2 \text{ (see A-1)}$$

The value of $C_t = 1.48$ is obtained from Fig. 4 using curve C and

$$\frac{H}{B} = \frac{7}{3.56} = 1.97$$

$$\text{Hence } W_e = 1.48 \times 17 \times 3.56^2 = 318.87 \text{ kN/m}$$

Because of the limited degree of compaction of the fill material on each side of the pipes, the fill material is assumed incapable of sharing the vertical load W_e with the pipes.

$$\text{Each pipe therefore is assumed to support } \frac{318.87}{2} = 159.44 \text{ kN/m}$$

The load factor $F_t = 1.5$ (see B-6)

$$\text{So, the required minimum test load} = \frac{159.44}{1.5} = 106.29 \text{ kN/m}$$

It follows from Table 4 of IS : 458-1971* that 1100 mm dia NP4 class pipe will not be suitable for this loading and a specially designed pipe is necessary.

Example 10:

Calculate the required class of a 800 mm diameter reinforced concrete pipe laid under negative projection conditions (see B-4) given the following data:

Internal diameter of pipe, d = 800 mm
 Wall thickness (assumed), t = 90 mm
 External diameter of pipe, D = 980 mm
 = 800 + 2 × 90

*Specification for concrete pipes (with and without reinforcements) (second revision).

Width of the trench, $B = D + 300$	= 1 280 mm
Unit weight of fill material (wet clay), w	= 18 kN/m ³
Bedding and foundation material (see B-4)	= Type B, earth
Settlement ratio, r_s	= 0.5
Positive projection ratio, p	= 0.7
Negative projection ratio, p'	= 1.0
Height of embankment above natural surface	= 10 m
Compaction of fill material each side of pipe [see B-4.3 (a)]	

Calculation

As $p' = 1$, then $h' = B \times p' = 1.28 \times 1 = 1.28$ m

So height of embankment H above top of pipe = $10 + 1.28 = 11.28$ m.

The vertical load on the pipe, W_e due to the fill material is calculated from the formula:

$$W_e = C_n w B^2$$

The value of $C_n = 5.1$ is obtained from Fig. 2 using the values $p' = 1.0$, $r_s = -0.5$, and $\frac{H}{B} = \frac{11.28}{1.28} = 8.81$

So, $W_e = 5.1 \times 18 \times 1.28^2 = 150.40$ kN/m

The load factor, $F_t = 2.5$

Therefore, the required minimum test load = $\frac{W_e}{F_t} = \frac{150.40}{2.5} = 60.16$ kN/m

From Table 3 of IS : 458-1971* it follows that 800 mm diameter NP3 Class pipe with a 0.25 mm cracking load of 59.3 kN/m will be just suitable.

*Specification for concrete pipes (with and without reinforcements) (second revision).

(Continued from page 2)

<i>Members</i>	<i>Representing</i>
SHRI L. SWAROOP	Orissa Cement Limited, New Delhi
SHRI H. BHATTACHARYYA (<i>Alternate</i>)	
SHRI G. RAMAN, Director (Civ Engg)	Director General, ISI (<i>Ex-officio Member</i>)
	<i>Secretary</i>
	SHRI N. C. BANDYOPADHYAY Deputy Director (Civil Engg), ISI
Concrete Pipes Subcommittee, BDC 2 : 6	
<i>Convener</i>	
SHRI N. G. JOSHI	Indian Hume Pipe Co Ltd, Bombay
<i>Members</i>	
SHRI B. SANKARASUBRAMONIA AYYAP	The Kerala Premo Pipe Factory Ltd, Quilon
SHRI S. N. BASU	Directorate General of Supplies and Disposals, New Delhi
SHRI T. N. UBOVEJA (<i>Alternate</i>)	
SHRI BHAGWANT SINGH	Concrete Pipe Manufacturers Association of India, New Delhi
SHRI H. S. MANIK (<i>Alternate</i>)	
CHIEF ENGINEER (SEWERAGE PROJECT)	Municipal Corporation of Greater Bombay, Bombay
DEPUTY CHIEF ENGINEER (SEWERAGE PROJECT) P & D (<i>Alternate</i>)	
SHRI A. W. DESHPANDE	National Environmental Engineering Research Institute (CSIR), Nagpur
SHRI V. A. MHAISALKAR (<i>Alternate</i>)	
SHRI G. R. HARIDAS	Gammon India Ltd, Bombay
SHRI P. C. JAIN	Engineer-in-Chief's Branch, Army Headquarters, New Delhi
SHRI SUCHA SINGH (<i>Alternate</i>)	
JOINT DIRECTOR (STANDARDS) B & S/CB	Research, Designs and Standards Organization, (Ministry of Railways), Lucknow
DEPUTY DIRECTOR (STANDARDS)	B & S/CB (<i>Alternate</i>)
SHRI P. D. KELKAR	The Indian Hume Pipe Co Ltd, Bombay
SHRI H. S. PASRICHA	Hindustan Prefab Ltd, New Delhi
DR N. RAGHAVENDRA	National Council for Cement and Building Materials, New Delhi
SHRI S. S. RAMRAKHYANI	Municipal Corporation of Delhi, Delhi
SHRI S. PRAKASH (<i>Alternate</i>)	
REPRESENTATIVE	Tamil Nadu Water Supply and Drainage Board, Madras
SUPERINTENDING SURVEYOR OF WORKS (NZ)	Central Public Works Department, New Delhi
SURVEYOR OF WORKS (NZ) (<i>Alternate</i>)	
SHRI V. M. TALATI	Spunpipe and Construction Co (Baroda) Pvt Ltd, Vadodara
SHRI A. V. TALATI (<i>Alternate</i>)	
DR B. VENKATESWARLU	Structural Engineering Research Centre (CSIR). Madras
SHRI Z. GEORGE (<i>Alternate</i>)	

PRINTED AT SIMCO PRINTING PRESS, DELHI (INDIA)

AMENDMENT NO. 1 JANUARY 1989
TO
IS : 783 - 1985 CODE OF PRACTICE FOR LAYING
OF CONCRETE PIPES

(First Revision)

(Page 14, Fig. 4) :

Substitute 'curve A' for 'curve E'

Substitute 'curve B' for 'curve D'

Substitute 'curve D' for 'curve B'

Substitute 'curve E' for 'curve A'

NOTE 1 — 'Curve C' remains as 'Curve C'.

NOTE 2 — The changes indicated above are applicable to both sets of curves.

NOTE 3 — There are no changes in the legends.

(BDC 2)

Printed at Simco Printing Press, Delhi